

NASA Technical Memorandum 105974

1N-03
19300
14-1

Users Manual for the NASA Lewis Three-Dimensional Ice Accretion Code (LEWICE 3D)

Colin S. Bidwell and Mark G. Potapczuk
Lewis Research Center
Cleveland, Ohio

December 1993

(NASA-TM-105974) USERS MANUAL FOR
THE NASA LEWIS THREE-DIMENSIONAL
ICE ACCRETION CODE (LEWICE 3D)
(NASA) 143 p

N94-21590

Unclas

NASA

G3/03 0198080

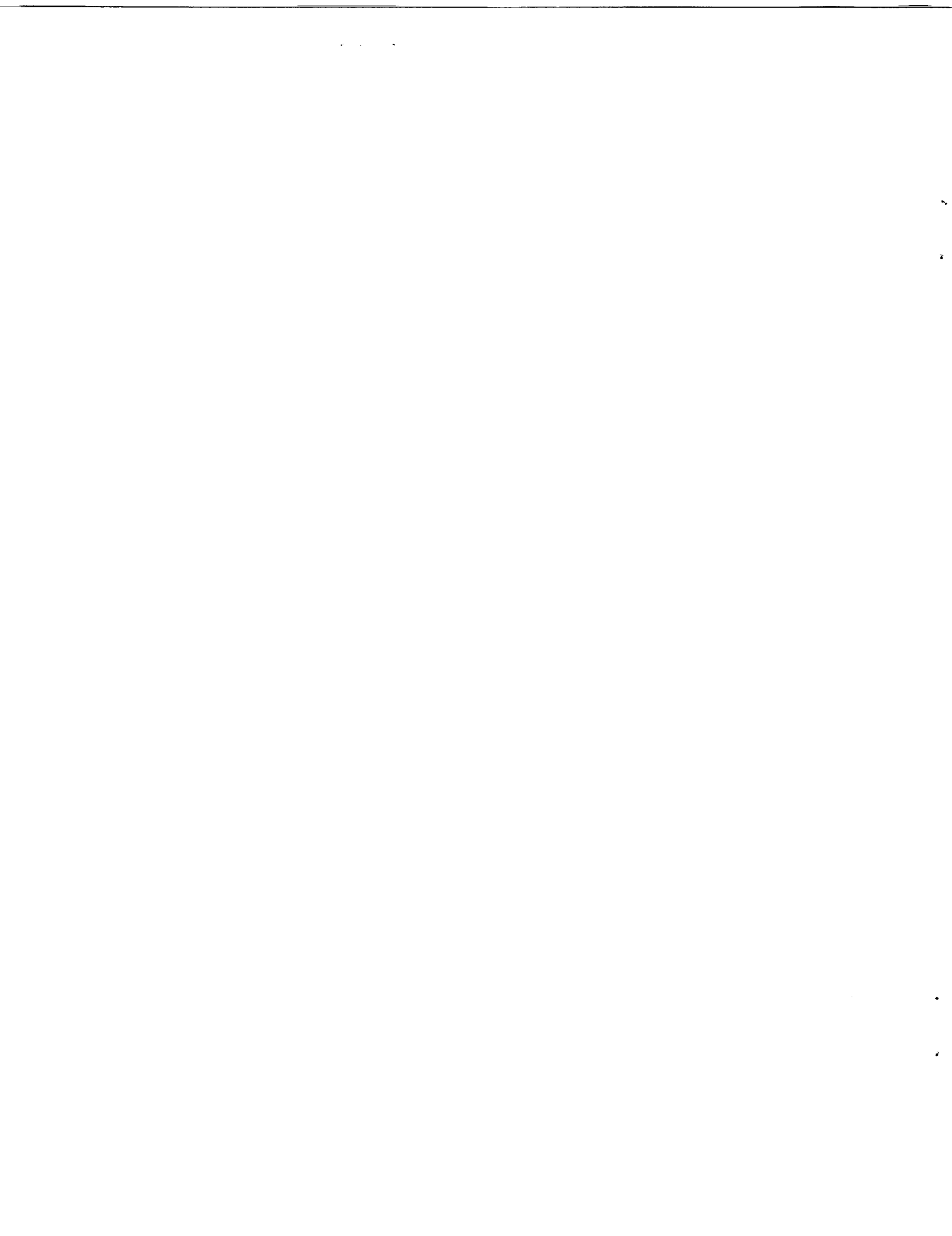

TABLE OF CONTENTS

SUMMARY	1
SYMBOLS	2
I. INTRODUCTION	4
II. PROGRAM UNITS	7
A. Introduction	7
B. Subroutine READIN	8
1. General Discussion	8
2. Printed Output	8
C. Subroutine FLOW	8
1. General Discussion	8
2. Printed Output	13
3. Peripheral Storage	22
4. Variable Array Dimensioning	23
D. Subroutine SETFLO	24
1. General Discussion	24
1. Printed Output	24
E. Subroutine BETAC	24
1. General Discussion	24
a. Search For Upstream Particle Release Points	25
b. Search For Tangent Trajectories	26
c. Calculation Of Impact Trajectories	27
d. Calculation Of Collection Efficiency	28
2. Printed Output	31
F. Subroutine STREM3D	33
1. General Discussion	33
b. Search For Stagnation Zone	33
b. Calculation Of Upper and Lower Streamlines	34
c. Projection Of Streamlines Onto Surface	34
2. Printed Output	35
G. Subroutine STREM2D	36
1. General Discussion	36
2. Printed Output	37
H. Subroutine BSTREM	37
1. General Discussion	37
2. Printed Output	39
I. Subroutine LEWICE2D	39
1. General Discussion	39
a. Modeling The Ice Growth Process	41
b. Ice Growth Along Streamlines	44
2. Printed Output	47

J. Subroutine BODMOD	47
1. General Discussion	47
2. Printed Output	49
K. Summary Of Subroutines	49
III. INPUT FILES	63
IV. REFERENCES	79
V. EXAMPLE CASE	81

USERS MANUAL FOR THE NASA LEWIS THREE-DIMENSIONAL ICE ACCRETION CODE (LEWICE3D)

Colin S. Bidwell
Mark G. Potapczuk

National Aeronautics and Space Administration
Lewis Research Center
Cleveland, Ohio

SUMMARY

A description of the methodology, the algorithms, and the input and output data along with an example case, for the NASA Lewis three-dimensional ice accretion code (LEWICE3D) has been produced. The manual has been designed to help the user understand the capabilities, the methodologies and the use of the code.

The LEWICE3D code is a conglomeration of several codes for the purpose of calculating ice shapes on three-dimensional external surfaces. A three-dimensional external flow panel code is incorporated which has the capability of calculating flow about arbitrary three-dimensional lifting and nonlifting bodies with external flow. A 4th order Runge-Kutta integration scheme is used to calculate arbitrary streamlines. An Adams type predictor-corrector trajectory integration scheme has been included to calculate arbitrary trajectories. Schemes for calculating tangent trajectories, collection efficiencies and concentration factors for arbitrary regions of interest for single droplets or droplet distributions have been incorporated. A heat transfer algorithm based on the NASA Lewis two-dimensional ice accretion code (LEWICE) can be used to calculate ice accretions along surface streamlines. A geometry modification scheme is incorporated which calculates the new geometry based on the ice accretions generated at each section of interest.

The three-dimensional ice accretion calculation is based on the two-dimensional LEWICE calculation. Both codes calculate the flow, pressure distribution, and collection efficiency distribution along surface streamlines. For both codes the heat transfer calculation is divided into two regions, one above the stagnation point and one below the stagnation point, and solved for each region assuming a flat plate with pressure distribution. Water is assumed to follow the surface streamlines, hence starting at the stagnation zone any water that is not frozen out at a control volume is assumed to run back into the next control volume. After the amount of frozen water at each control volume has been calculated the geometry is modified by adding the ice at each control volume in the surface normal direction.

SYMBOLS

A, A2	Parametric slope matrix for a line in space
A_m	Trajectory flux tube area at surface
A_o	Trajectory flux tube area in free stream
A_{sur}	Surface area of a segment on the streamline
B, B2	Parametric intercept matrix for a line in space
B^k	Vortex pair strength for kth lifting strip
C_p	Specific heat, J/kg
DCOR	Coarse step size for tangent trajectory search
DFINE	Fine step size for tangent trajectory search
DS_o	Trajectory flux tube width in free stream
DS_m	Trajectory flux tube width at surface
DICE	Ice thickness array along streamline
DICES	Ice thickness save array for streamlines
d_{ice}	Ice thickness array
f	Freezing fraction at a segment
h_c	Convective heat transfer coefficient
i	Enthalpy
IFLOW	Flow field calculation flag
IRUN	Trajectory calculation control flag
ICE	Ice accretion calculation control flag
IMOD	Geometry modification control flag
ISUP	Upper streamline release point array counter
ISLO	Lower streamline release point array counter
ISTRF	Streamline calculation control flag
IST1, IST2	Flags denoting two closest sections of interest to a given N-line
L_f	Heat of fusion, J/kg
L_v	Heat of vaporization J/kg
m	mass flow rate
NBR	Number of rows of trajectories to be released at a section of interest
NBC	Number of columns of trajectories to be released at a section of interest
NPSEC	Flag describing region of interest
NPTS1, NPTS2	Number of points in two the two closest streamlines to a given N-line
PIN, PIN1, P1,P2	Point arrays
PLN	Array containing coefficients of equation of a plane
q_c	Convective heat flux, W/m^2
T	Temperature, K
TL	Parametric distance of an N-line from two closest sections of interest

SYMBOLS CONTINUED

u	Weighting factor in j direction for collection efficiency interpolation
v	Weighting factor in i direction for collection efficiency interpolation
V	Velocity M/S
VCRIT	Stagnation point search velocity criteria
XNEW, YNEW, ZNEW,	Coordinate arrays describing the on-body streamline.
XSCI, YSCI, ZSCI	Arrays describing upstream release points for trajectories passing through points describing the section of interest.
XTIP, YTIP, XTIP	Arrays describing upstream release points for tangent trajectories
XSEC, YSEC, ZSEC	Arrays describing the region of interest.
XSTOP	Stream wise stopping point for all trajectory and streamline calculations
XL,YL, ZL	Scan line arrays for stagnation point search
XN,YN,ZN	Arrays of surface normals for streamline
x_i	Surface coordinates of impingement cell
x_{ci}	Location of centroid of A_m
x_{si}	Location along surface streamline
X_j	Displacement vector from $x(i,j)$ to $x(i,j+1)$
X_i	Displacement vector from $x(i,j)$ to $x(i+1,j)$
X_s	Displacement vector from $x(i,j)$ to x_s
α	Pitch angle of geometry
β	Collection efficiency
ρ_i	Density of ice at segment i
Δs	Length of segment along surface streamline
Δt	Time increment for ice accretion
ψ	Sideslip angle of geometry
v	Rotation angle of surface droplet flux tube
σ_i	Source strength of a panel

Subscripts

a	Air
aw	Adiabatic wall
c	Critical; convection
e	Evaporation: condition at the edge of the boundary layer

SYMBOLS CONCLUDED

i	Ice
(i)	Control volume
r_{in}	Runback into control volume
r_{out}	Runback out of control volume
sur	surface condition
s	Static condition
T	Total condition

I. INTRODUCTION

The LEWICE3D code is a conglomeration of several codes for the purpose of calculating ice shapes on two-dimensional external surfaces. A three-dimensional external flow panel code is incorporated which has the capability of calculating flow about arbitrary three-dimensional lifting and nonlifting bodies with external flow. A 4th order Runge-Kutta integration scheme is used to calculate arbitrary streamlines. An Adams type predictor-corrector trajectory integration scheme has been included to calculate arbitrary trajectories. Schemes for calculating tangent trajectories, collection efficiencies and concentration factors for arbitrary regions of interest for single droplets or droplet distributions have been incorporated. A heat transfer algorithm based on the NASA Lewis two-dimensional ice accretion code (LEWICE) can be used to calculate ice accretions along surface streamlines. A geometry modification scheme is incorporated which calculates the new geometry based on the ice accretions generated at each section of interest.

The three-dimensional ice accretion calculation is based on the two-dimensional LEWICE calculation. Both codes calculate the flow, pressure distribution, and collection efficiency distribution along surface streamlines. For both codes the heat transfer calculation is divided into two regions, one above the stagnation point and one below the stagnation point, and solved for each region assuming a flat plate with pressure distribution. Water is assumed to follow the surface streamlines, hence starting at the stagnation zone any water that is not frozen out at a control volume is assumed to run back into the next control volume. After the amount of frozen water at each control volume has been calculated the geometry is modified by adding the ice at each control volume in the surface normal direction.

The basic methodology of the three-dimensional ice accretion analysis is to divide the three-dimensional ice accretion process into two-dimensional processes along streamlines of interest (fig. 1). The user inputs regions of interest on the three-dimensional body (e.g. leading edge points). A streamline is then calculated along the body's surface from the centroid of this region of interest. Impingement rates and velocities are calculated along this streamline. This information is input to a two-dimensional heat transfer module which calculates ice growth along the streamline. This information is used to generate a new geometry at the streamline location. This process is repeated for each streamline of interest on the three-dimensional body. Upon completing the ice growth calculations the geometry is modified and the flow field is updated. The above steps are repeated for as for each time step.

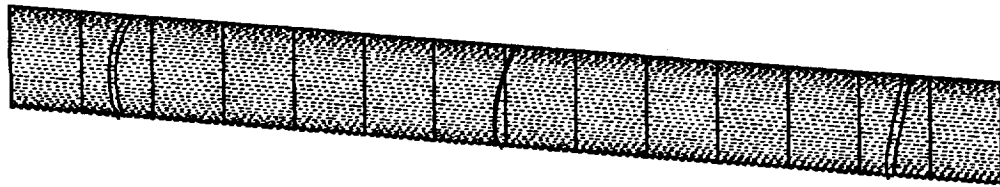

(a) Clean swept airfoil with three streamlines (top view).

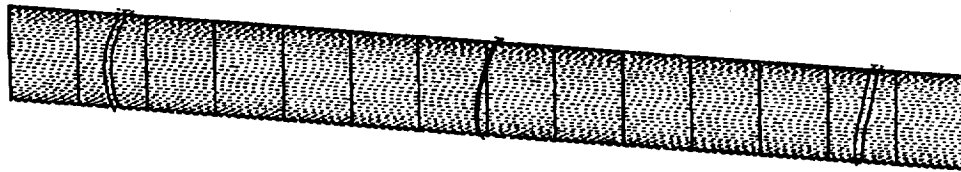

(b) Clean swept airfoil with three iced streamlines (top view).

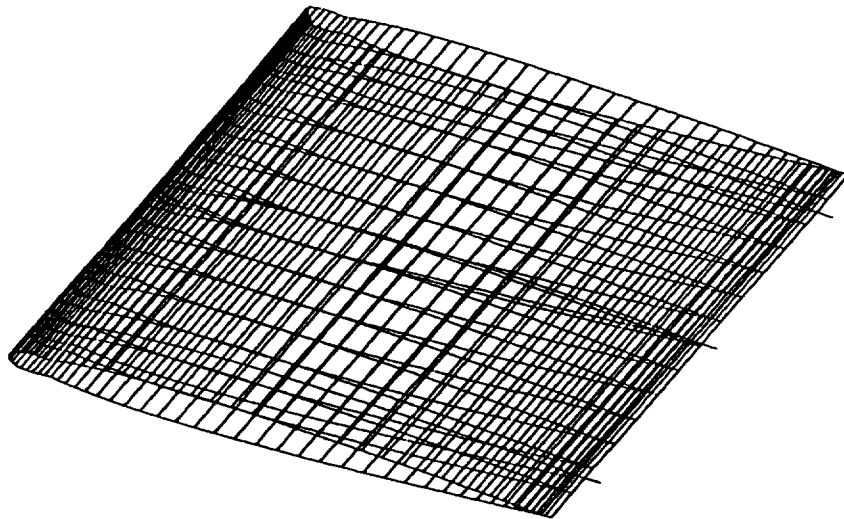

(c) Iced swept airfoil resulting from three iced streamlines.

Figure 1. - Airfoil with several sections of interest.

The three-dimensional (3D) analysis then, can be broken into 6 basic steps. First, a flow field is generated for the body. Second, impingement efficiency is calculated at the region of interest. Third, a streamline is calculated at the region of interest. Fourth, impingement rates along the streamline of interest are found by interpolation. During the Fifth step ice accretion along the streamline is calculated using the two-dimensional (2D) heat transfer module. The Sixth step

involves generating a new body from the ice accretion information.

A 3D Hess-Smith panel code (ref. 1-5) is used to generate the flow field used in the trajectory and heat transfer calculations. The code can accommodate lifting and non-lifting geometries or combinations thereof such as entire airplanes (fig. 2). If desired, a Prandtl-Glauert correction can be made for compressible cases. The code can also handle leaking panels to emulate inlets for instrument orifices. The code also has a variable dimension feature which allows easy adaption to different computers or problems.

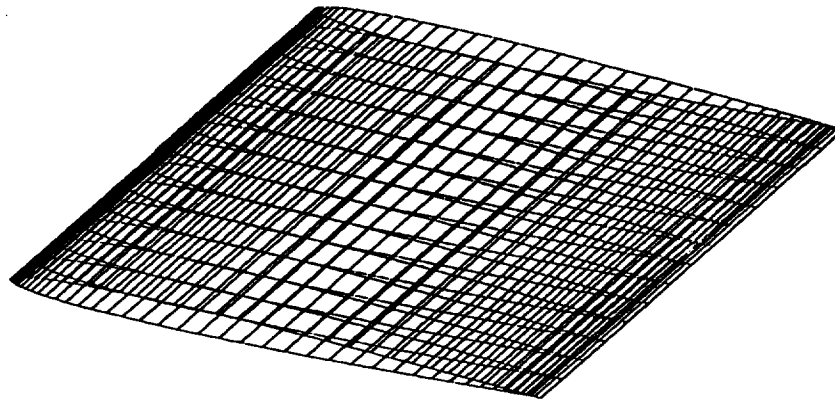

(a) Finite swept wing

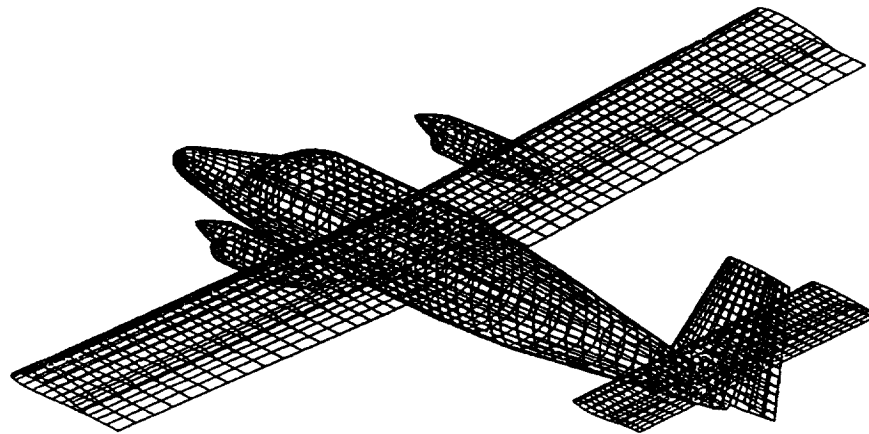

(b) Twin Otter aircraft.

Figure 2. - Panel representation of different types of geometries

The trajectory code is basically that developed by Hillyer Norment (ref. 5) with one additional feature. The code uses the Hess-Smith flow field along with an Adams-type predictor-corrector algorithm developed by Krogh (ref. 6). An added feature is the ability to calculate local collection efficiency from the impacting trajectories. The code is used here to generate an array of

impingement efficiencies for each region of interest.

The surface streamline is calculated using a 4th order Runge-Kutta integration scheme. The streamline integration is carried forward from the stagnation region for both the upper and lower surfaces at the region of interest.

A linear interpolation scheme is used to determine the collection efficiency along the streamline from the matrix of collection efficiencies generated above in the trajectory step.

The 2D ice accretion calculation is basically that of the LEWICE program generated at Lewis. This code is described in detail in reference 7.

The new geometry is generated from ice accretion information and from the surface normal information and final trajectory angle information. Each new point on the streamline is generated by adding the ice accretion multiplied by either the surface normal vector or by the final trajectory tangent vector to the old streamline point.

II. PROGRAM UNITS

A. Introduction

There are nine basic program units comprising the 3D ice accretion calculation: READIN, FLOW, SETFLO, BETAC, STREM3D, STREM2D, BSTREM, LEWICE2D, AND BODMOD. A brief description of each of these modules is given along with a flow chart. Figure 3 shows an overview of the LEWICE3D job stream. Section J contains tables giving a brief description of each sub-routine used in the above modules.

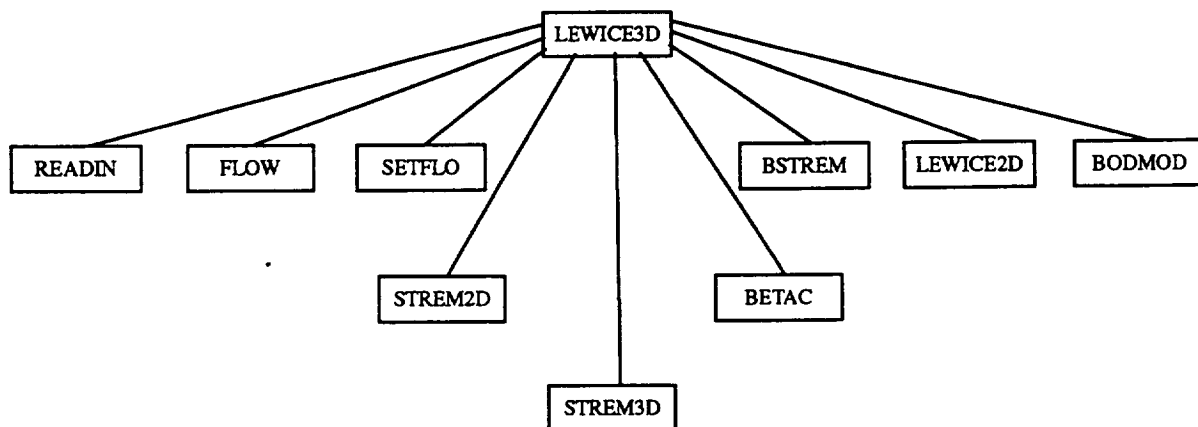

Figure 3. - LEWICE3D segmentation tree structure.

B. Subroutine READIN

1. General Discussion

The module READIN reads the job control file (unit INPUT) and initializes important program control variables. All input data (unit INPUT) is in "NAMELIST" format. Three "NAMELISTS" are input from unit INPUT: IMPING, TRAJ and ICEIN. A brief description of the variables in each of the NAMELISTS is given in the INPUT FILE section. IMPING contains control variables for the Hillyer Norment Trajectory codes. These variables are described in the user's manual for the trajectory codes (ref. 5). TRAJ contains the control variables for the overall calculation including how many stations are to be used, number of trajectories to be used, whether to run the flow field code, LEWICE or streamline calculations, etc. ICEIN contains control variables for the 2D LEWICE calculation. These variables are described in the LEWICE manual.

2. Printed Output

Subroutine READIN prints job control information to several output files (OUPUT, JOB-SUM). This information is self explanatory.

C. Subroutine FLOW

1. General Discussion

Subroutine FLOW is essentially the HESS-Smith 3D panel code put into subroutine form. Hillyer Norment gives a good description of the Hess-Smith code in his user's manual (ref. 5, pages 10-14), and this description is repeated here for completeness. Figure 4 shows a flow chart of the flow field (subroutine FLOW) and velocity calculations (subroutine FLOVE2 and FLOVEL). Subroutine FLOVE2 is the original velocity calculation algorithm developed by Hillyer Norment (ref. 5). Subroutine FLOVEL is a vectorized version of FLOVE2 which was developed at LEWIS by Bidwell and Mohler. Subroutine FLOVEL evaluates velocities about 20 % faster than FLOVE2 on computers that do not support vectorization and about 80% faster on machines supporting vectorization. The algorithm cannot be used in cases where the piecewise linear vorticity option has been chosen (i.e. PESWIS = TRUE).

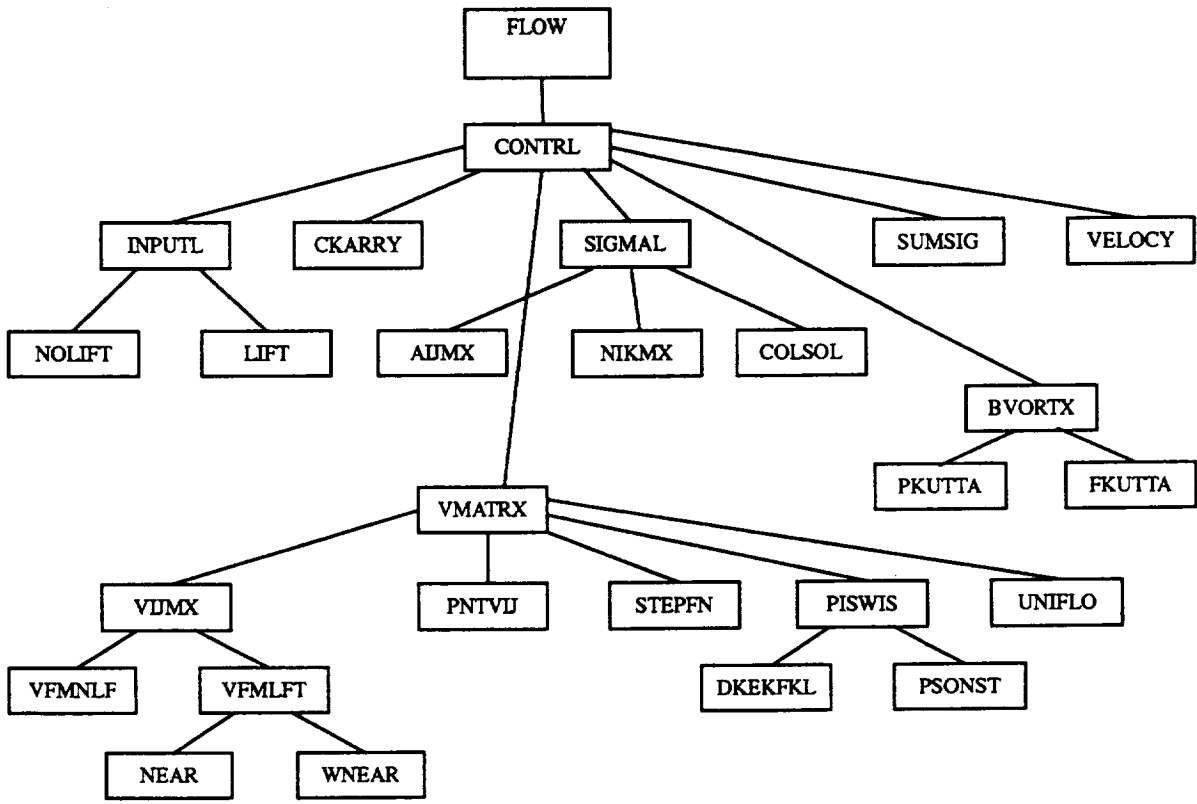

(a) Subroutine FLOW

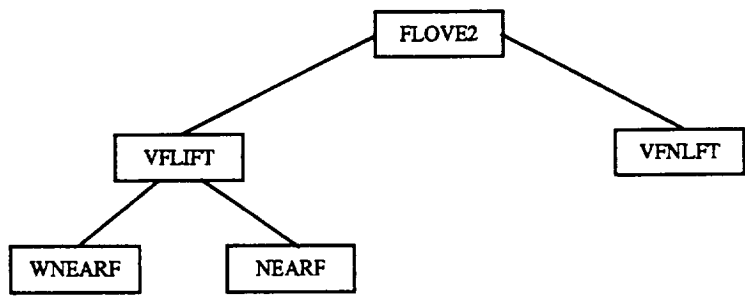

(b) Subroutine FLOVE2

Figure 4. Flow field and velocity calculation segmentation tree structures.

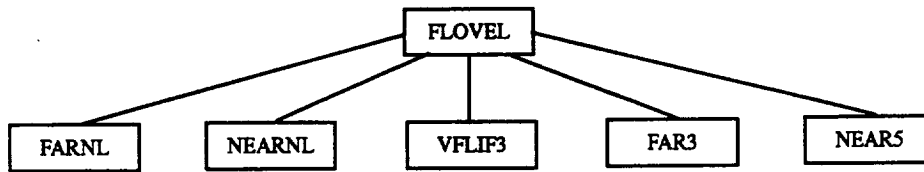

(c) Subroutine FLOVEL

Figure 4. -Concluded. Flow field and velocity calculation segmentation tree structures.

The methods and codes of Hess (ref. 1) and Hess and Smith (ref. 2,3) are used for calculation of lifting and nonlifting potential flow about arbitrary three-dimensional bodies. Lifting bodies (i.e., airfoils) alone, nonlifting bodies alone, or combinations of lifting bodies with nonlifting bodies (e.g., combinations of airfoils and fuselages) can be treated. Effects of flow into an inlet, for example an instrument aperture, can be accounted for provided the intake flow rate, in terms of fraction of free stream air speed, is specified. The method is restricted to subsonic airspeeds, but for free stream Mach numbers greater than 0.5, the Prandtl-Glauert method is used to correct approximately for compressibility effects. Since potential flow is computed, neither viscous effects nor turbulence are treated.

The code requires input of a digital description of the body surface, and for purposes of organizing the data as well as for computing flow, the body surface is partitioned into sections which are designated as either lifting or nonlifting. In either case, the surface is represented by contiguous, plane quadrilateral panels, usually called elements (fig. 2). For nonlifting sections there are few restrictions on the manner in which the elements can be arranged to represent the surface other than those required for organization. Lifting sections are restricted as follows: each must consist of strips of elements, the strips being oriented parallel to the chordwise direction of the airfoil each strip must have the same number of elements and wake elements must be included after the trailing edge of each strip. Both lifting and nonlifting portions of the body may be described by more than one section.

Each on-body element (which is in the flow) is taken to be a potential flow source. The source is a distributed one, with the distribution being uniform over the surface of the element, and each element, for example the j^{th} , is characterized by a unique source density, σ_j . In addition, each strip of elements in a lifting section is characterized by having a unique value of lift vorticity associated with it. This quantity, for example for the K^{th} lifting strip, $B^{(K)}$, represents vortex strength per unit path length around the strip (fig. 5), and it represents the sum of contributions from all panels in the strip. Velocities induced by these vorticities are treated as onset flows. Thus, there is an onset flow from each lifting strip plus the free stream onset flow. It is necessary to compute an independent source density for each of these onset flows for each on-body quadrilateral panel: if there

are N on-body panels, K lifting strips, and one free stream flow, $N(K + 1)$ values of σ must be computed. Source densities are determined by solving large systems of linear equations that represent the effects of all onset flows on all panels, plus the mutual interactions of all distributed sources, under boundary conditions for zero flux through the centroid (also called control point) of each on-body panel, or specified fraction of free stream flux through each inlet panel.

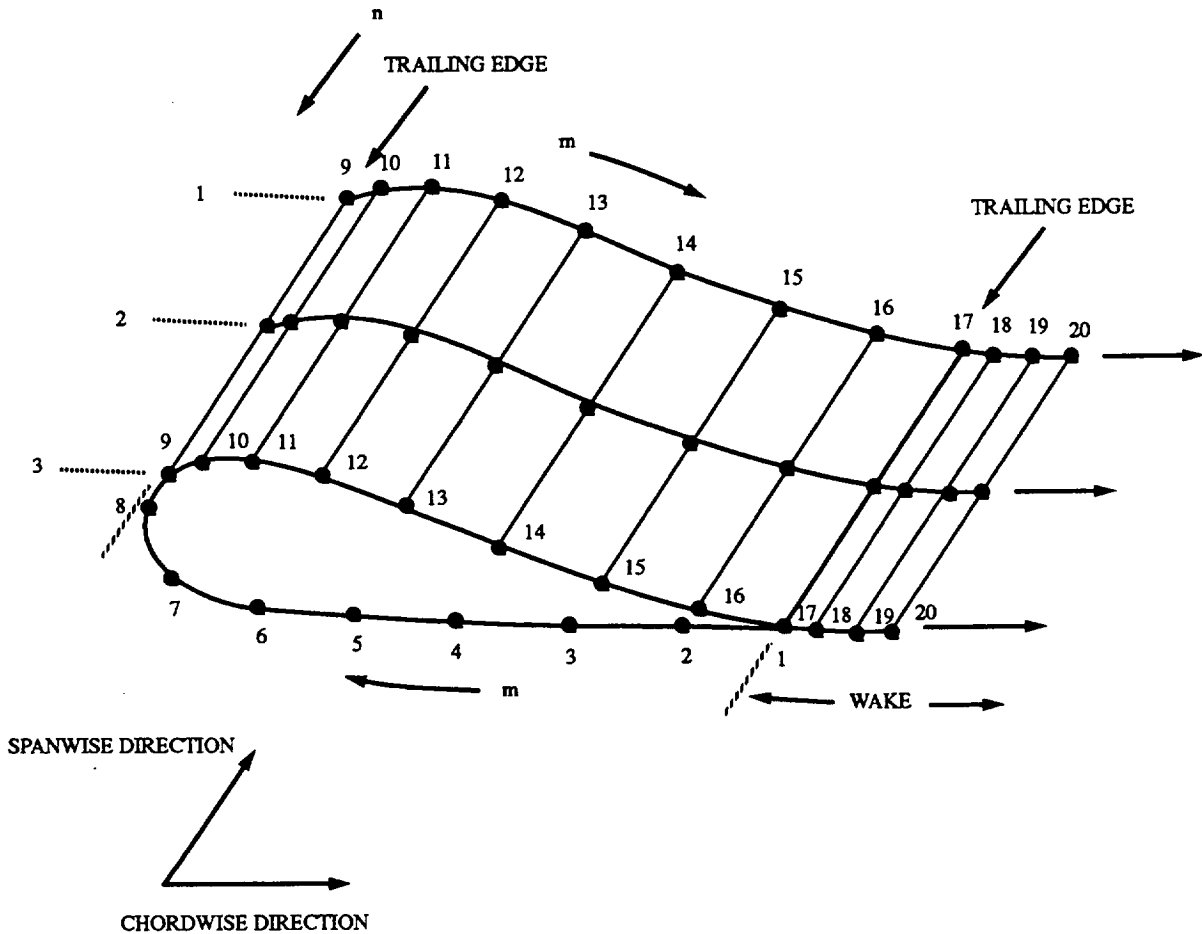

Figure 5. - Organization of m and n lines in a lifting section. A lifting strip is delineated by sequential n lines, and extends over the complete circuit from $m = 1$ at the trailing edge, along the underside to and around the leading edge, back to the trailing edge, and finally back to the furthest aftward extent of the wake.

Determination of vortex strengths requires an additional constraint, the Kutta condition, and this is supplied by user-selection of one of two optional methods which are designated as “flow tangency” and “pressure equality.”

Lift vorticity is computed by a novel method developed by Hess (ref. 1). To circumvent

problems that have been found to result from use of vortex filaments in prior work, and to ensure that potential flow results from the vorticity distribution and that individual infinitesimal vortex lines either form closed curves or go to infinity, Hess has developed a method by which vortex sheets on the body and wake surfaces can be expressed in terms of dipole sheets on the same surfaces. Hess summarizes the method as follows:

“A variable-strength dipole sheet is equivalent to the sum of: (1) a variable-strength vortex sheet on the same surface as the dipole sheet whose vorticity has a direction at right angles to the gradient of the dipole strength and a magnitude equal to the magnitude of this gradient, and (2) a concentrated vortex filament around the edge of the sheet whose strength is everywhere equal to the local edge value of dipole strength.”

Mathematical details are given in appendix A of reference 1.

For particular body geometry and orientation relative to the free stream, the source densities and vortex strengths are calculated only once, and then these can be used to calculate flow velocity at any space point exterior to the body. The primary functions of the DUGLFT codes are to calculate the σ_j and $B^{(k)}$ and store these quantities, along with other requisite data, for use by subroutine FLOVEL in calculating flow velocities. Subroutine FLOVEL is called as needed by programs TRAJEC, CONFAC, and ARYTRJ to provide flow velocities for trajectory and flow velocity array calculations.

In calculating each flow velocity, contributions from all quadrilateral elements are summed. There are three sets of algorithms for computing contributions from individual elements: (1) for elements that are close to the calculation point, detailed calculations are used that account for exact element geometries, (2) for elements at intermediate distances multipole expansions are used, and (3) for remote elements the point source approximation is used. Mathematical details are given in references 1,2 and 3 with emphasis on lifting flow in reference 1 and emphasis on nonlifting flow in references 2 and 3. The reader is strongly urged to study these references closely before attempting to use this code. Reference 4 consists of a code users manual for the lifting flow calculations described in reference 1.

Calculation accuracy is discussed in the Validation section in the Hillyer manual (ref. 5). Of course accuracy also depends on the fineness of resolution of the element description of the body, and naturally some compromise is called for. The smaller the elements the finer the resolution, and the fewer of them for which the most exacting of the three algorithms must be used. On the other hand, the number of elements increases inversely as the square of their linear size. In past studies on airplanes we have used the following paneling criteria For those parts of the airplane traversed by particle trajectories, we try to keep the element edges between 6" and 8" in length. Where allowed by simplicity of surface shape, remote elements can be larger. Remote downstream complexities of shape are ignored or treated approximately. For example, if interest is confined to the forward fuselage, then the remainder of the fuselage can be represented as a cylinder of constant cross-section which is extended to approximately five times the length of the of the nose section (as recommended by Hess and Smith, ref. 2), and the wings can be ignored entirely. The following are basic requirements of the method that apply to all calculations

1. A uniform, unit-speed free stream approximately in the direction of the positive x-axis.
2. Normalization of all velocities to be consistent with the unit free stream speed.
3. Normalization of all distances by a user-specified characteristic dimension of the body.

Surface point coordinates may be recorded in any convenient units and can be appropriately translated and scaled, to meet requirement 3 above, during processing via use of SR's PATPRS and DATPRS. These subroutines also allow rotation of the body about the y axis to adjust attitude angle. The coordinate system used for the calculations is described on pp. 19-20 (ref. 5).

The unit free stream speed is assumed by program DUGLFT, and the distance normalization, if required, is done during preliminary data processing as indicated above. For trajectory calculations, the user specifies the true free stream speed and the normalization length, and the codes automatically handle any additional normalizing or scaling that is required.

The module FLOW computes a flow field for the geometry input on unit NGEOM (DUGLIFT format) and saves it on unit FLOWF. This module is executed only if IFLOW=1 (NAMELIST TRAJ). If the flow field code is not executed (i.e. IFLOW=0) then the flow field must be provided on unit FLOWF. The Hess-Smith 3D flow field code is used in subroutine form here to generate the flow field. The execution time for the flow field calculation is proportional to the square of the number of panels. A 1200 lifting panel model with one section required 80 seconds of CPU time on the CRAY XMP while that for a 3200 panel model with one section required 630 seconds. Two basic requirements have been found to date for the ice accretion calculations. The first is a numerical one for the panel method used. The requirement is that the aspect ratio of any panel should not be greater than 100. The source strength calculation will converge for larger aspect ratios but the vortex calculation will not. The requirement grows more stringent with angle of attack and ratios as high as 100 may not be allowed for some geometries. The second requirement is that to produce a smooth beta curve there must be approximately one panel per trajectory released in the z-direction (i.e. if 20 trajectories were to be released between the impingement limits then 20 panels are required between the impingement limits at the surface to ensure a smooth beta curve.

2. Printed Output

Subroutine flow produces several output files (units FLSUM, FLOWF). Unit FLSUM is a summary of the flow field computation and contains varying amounts of information depending on the flags set in the flow input file (unit NGEOM). Any error messages from the flow field computation will be found in unit FLSUM. Unit FLOWF contains the flow field information in binary format to be used in the calculation of velocities in the trajectory routines. A description of these files is taken from reference 5.

The flow field calculation summary output (unit FLSUM) consists of two main parts, plus a summary of input control data, various error condition messages, and optional outputs of data that are used for debugging.

1. The first printout is a summary of input control data, and is self-explanatory.
2. Next, which is the first main part, is a printout (from NOLIFT and LIFT) of element data. Elements are designated as lifting or non-lifting.

A short table follows (from INPUTL) titled TABLE OF INPUT INFORMATION, which summarizes the data in terms of section type, number of elements per section, number of strips, etc.

3. In the course of computing velocities induced by each element on all others, additional summary information is printed (from VIJMX) for each section. For lifting strips, this includes information on ignored elements which does not appear elsewhere.
4. If the piecewise linear option for determination of spanwise variation of vortex strength is used, strip widths, W_k , and parameters D_k , E_k , F_k (ref. 3, sec. 7.11) are printed for each strip for each section, along with a summary of edge conditions (NLINE1 and NLINEN).
5. A short statement is printed (from COLSOL) regarding the dimensions of the matrix that are solved to determine element source strengths, and the number of right-hand-sides (i.e., number of uniform onset flows plus number of lifting strips) for which the solutions are obtained.
6. The second main printout (from PRINTL) contains the final results of the calculations. A printout for each on-body element is labeled as follows.

X0, Y0, Z0	Control point coordinates.
VX, VY, VZ	Flow velocity components at the control point
VT	Velocity magnitude
VTSQ	Square of velocity magnitude
CP	Pressure coefficient = $1.0 - VTSQ$
DCX, DCY, DCZ	Direction cosines of the velocity components
NX, NY, NZ	Components of the unit normal to the plane of the element
SIG	Source density
VN	Velocity component in the direction of the unit normal

AREA

Area of the element

Printouts for off-body and Kutta points are similarly labeled.

Also printed are vector components for pressure force and moment for each strip, each section and for the entire body, as well as a table of vortex strength per unit length, $B^{(k)}$, for each lifting strip.

7. Error messages (ref. 4).

(a) Message: MISMATCH OF ELEMENTS IN A LIFTING STRIP IS DETECTED. ELEMENTS FORMED XXX, ELEMENTS INPUT XXX, COMPUTATION TERMINATED. (SR INPUTL)

Cause of error: Inconsistent input data. The program sums the number of on-body elements plus the wake elements specified on card 8. This sum does not match with the elements formed from the input coordinates.

Action: Check the lifting body information card (card 8) and the quadrilateral corner point coordinates cards (cards 12). The number of points on an n-line should equal the number of elements plus 1.

For example: If in a lifting section each lifting strip consist of 10 on-body elements and 1 wake element, the total number of elements is 11, and there should be 12 points on each n-line input via cards no. 12.

(b) Message: ERROR IN IGNORED ELEMENT COUNT XXX, SHOULD BE XXX. (SR LIFT)

Cause of error: Erroneous specification of ignored element information.

Action: Check card 10 to make sure the ignored element information is properly specified.

(c) Message: LABEL ERROR IN NONLIFTING VFORM. (SR VFMNLF)
LABEL ERROR IN LIFTING VFORM (SR VFM-LFT)

Cause of error: Geometric data for each element strip, preceded by a

lifting or nonlifting label are stored on unit 4. The error occurs when a labeling mix-up is detected during input of the data from unit 4 for calculation of velocities. That is, data for a strip labeled lifting are encountered during computation for a nonlifting section. or vice versa.

Action: Check that the number of lifting strips specified on card no. 8 for each lifting section corresponds with the cards no. 12 input.

(d) The following messages pertain to errors in specification of variable dimensions (SR CKARRY).

ELEMENT CAPACITY, NONX = XXX IS LESS THAN TOTAL ELEMENTS, NON= XXX

STRIP CAPACITY, NSTX = XXX IS LESS THAN TOTAL STRIPS, NSTRP = XXX

LIFTING SECTION CAPACITY, LFSX= XXX IS LESS THAN TOTAL SECTIONS, ISECT = XXX

LIFTING STRIP CAPACITY, NOBX = XXX IS LESS THAN TOTAL LIFTING STRIPS, LSTRP = XXX

N2BX = XXX IS NOT GE TWICE NOBX AS REQUIRED, NOBX = XXX

NSLX = XXX IS LESS THAN THE MAX. NO. OF STRIPS IN A LIFTING SECTION, WHICH IS XXX

CAPACITY OF ARRAY WKAREA, NWAX = XXX, USED BY COLSOL TO DETERMINE SOURCE STRENGTHS, IS INSUFFICIENT. IT MUST BE GREATER OR EQUAL TO XXX

NWAX = XXX IS NOT GREATER OR EQUAL TO NO. OF LIFTING STRIPS = XXX CUBED, AS REQUIRED FOR THE PRESSURE EQUALITY KUTTA OPTION.

Cause of error: Array dimensions are inadequate to accommodate the input data.

Action: Check array dimensions and variable array parameters against the storage demands of the element data input via cards no. 12. Also check input parameter

LIFSEC, NSORCE, NWAKE, NSTRIP, and IX-FLAG.

(e) Messages: XXX ANGLES OF ATTACK HAVE BEEN SPECIFIED, ONLY ONE IS ALLOWED SINCE COMPRESSION EFFECTS ARE CONSIDERED.

ANLGE OF ATTACK, + - XXX, + - XXX, +- XXX- IS INAPPROPRIATE FOR A CASE WITH COMPRESSION CORRECTION. (SR CKARRY)

Cause of error: Only one uniform onset flow (i.e. free stream) is allowed if the compressibility correction is applied (MACH > 0.0 on card no. 2). Moreover, the direction cosines (ALPHAX, ALPHAY, ALPHAZ) of this onset flow must be (1.0, 0.0, 0.0; card no. 4).

Action: Set IATAACK = 1 on card 2, and/or specify direction cosines on card 4 as stated above.

(f) Message: THE NUMBER OF KUTTA POINTS SPECIFIED IS INCORRECT AND SHOULD BE XXX (SR CKARRY)

Cause of error: The flow tangency Kutta option has been specified, and the number of Kutta points specified by input (cards no. 9, 13 and 14) does not equal the number of lifting strips.

Action: Check parameter KUTTA on card 9, and the number of KUTTA data points on cards 13 and 14, against the number of lifting strips input via cards no. 12 (Do not count extra strips.)

(g) Message: ERROR IN VFORM. THE ELEMENTS FORMED DO NOT CORRESPOND TO THE NO. OF BODY ELEMENTS. (SRS VFMNLF AND VFMLFT)

Cause of error: Element tally recorded by SR INPTL does not match with tally recorded from input of data from unit 4 during velocity calculation.

Action: Check lifting strip specification data on card 8 for consistency with cards no. 12 input data.

(h) Message: AFTER XXX ITERATIONS, DELTA B STILL

DID NOT CONVERGE TO THE GIVEN CRITERION/ LARGEST DELTA B= +- XXX.XXX/ PROGRAM PROCEEDS WITH THE MODS CURRENT VORTEX STRENGTH. (SR PKUTTA)

Cause of error: Non-convergence of vortex strengths, B, calculation via the pressure equality Kutta condition method (ref.4, sec. 7.13.2).

Action: Check the cards no. 12 input data.

(i) Message: THIS CODE SHOULD BE APPLIED TO FIRST STRIP

or,

THIS CODE SHOULD BE APPLIED TO LAST STRIP. (SR DKEKFK OR PSONST)

Cause of error: Improper specification of NLINE1 or NLINEN for piecewise linear option. Specifically, either NLINE1 = 2 or NLINEN =3 is specified, both of which are forbidden.

Action: Check card 8 specifications

(j) Message: XXX ON-BODY POINTS MISSED. EXECUTION TERMINATED. (SR PRINTL)

Cause of error: The number of on-body source elements tallied during final printout does not agree with the count tallied during input.

Action: Check input data.

(k) Message: XXX KUTTA POINTS MISSED, EXECUTION TERMINATED. (SR PRINTL)

Cause of error: The number of Kutta points tallied during the final print out does not agree with the number specified by parameter KUTTA on card 9.

Action: Check the number of Kutta points input via cards 13 and 14 against parameter KUTTA.

(l) Message: XXX OFF-BODY POINTS MISSED, EXECU-

TION TERMINATED. (SR PRINTL)

Cause of error: The number of off-body points tallied during final printout does not agree with the number tallied during input.

Action: Check input data.

8. Optional Printouts for Use in Debugging

(a) Geometrical data for each element. (IOUT = TRUE, card 3, SR INPUTL). For each nonlifting element is printed the element sequence number and twenty-nine geometric quantities (ref.4, sec. 9.51) and for each lifting element is printed the element sequence number and forty-five geometric quantities (ref. 3, sec. 7.2).

(b) Source induced velocity matrix, \vec{V}_{ij} . (MPR = 1, card 2; SR PNTVIJ)

COLUMN Matrix column number (j)

CNTRL PT Control point number (i)

VXS, VYS, VZS Velocity components

if LIFSEC is greater than 0 (card 2), dipole induced velocity matrices, \vec{V}_{ij}^F , \vec{V}_{ik} , also are printed.

STRIP Lifting strip number

CNTRL PT Control point number

VXF, VYF, VZF First velocity components

VXS, VYS, VZS Second velocity components

(c) Onset flow matrices, $\vec{V}_i^{(k)}$, $\vec{V}_i^{(\infty)}$. (MPR = 3, SR UNIFLO)

ONSET FLOW NO.

CONTROL POINTS Control point number

X-FLOW, Y-FLOW Onset flow velocity components

Z-FLOW

(d) Dot product matrices, A_{ij} , $N_i^{(k)}$, $N_i^{(\infty)}$ (MPR > = 2, card 2 SR AJMX and NIKMX)

COLUMN	Matrix column number (j) .
AIJ	Elements of A_{ij}
FLOW NO.	Onset flow number (k)
RIJ	Right side of equation (7.12.5)

- (e) Source density matrix (MPR > 2, card 2; PGM SIGMAL) SOLUTION OBTAINED AFTER COLSOL FLOW NO. Onset flow number. Element source densities, $\sigma_i^{(k)}$, $\sigma_i^{(\infty)}$, are printed eight to a line.

The following data are stored on unit FLOWF in binary format for use later in the velocity calculations. Actual record structures are more easily determined by examining the SR SETFLO FORTRAN listing.

CASE	Body identifier (input card 2)
ISECT	Number of sections (lifting plus nonlifting)
LIFSEC	Number of lifting sections (input card 2)
ALPHAX(1) ALPHAY(1) ALPHAZ(1)	Uniform onset flow direction cosines (card 4)
SYM1 SYM2	Floating point equivalent of input parameters NSYM1 and NSYM2 (card 2)
NSYM	Total number of symmetry planes
NSTRP	Total number of strips, including extra lifting strips if input.
BETAM	$\text{SQRT}(1-N_M^2)$ where N_M is free stream Mach number
BETSQ	$1-N_M^2$
NLT (NSTRIP)	Number of elements on each strip, including extra strips, and ignored and wake elements are counted. It is negative for the last strip of each section.
NTYPE (ISECT)	Section type indicator. 0 for nonlifting

1 for lifting

NLINE Number of strips in a section, not including extra strips
(ISECT)

If LIFSEC GT 0:

IGW If true, there are ignored elements.

LASWAK If true, the semi-infinite final wake element option is exercised

PESWIS If true, the piecewise linear method for computing spanwise variation of lift vorticity is used.

NSTRIP See input card 8

(LIFSEC)

NLINE1(LIFSEC)

NLINEN(LIFSEC)

NSORCE(LIFSEC)

IXFLAG(LIFSEC)

IG1(I,J) Only if IGW = TRUE (see input card 10)

IGN(I,J)

For each nonlifting element, the twenty-nine geometric quantities written on unit 4 by SR NOLIFT.

For each lifting element, the fifty-seven geometric quantities written on unit 4 by SR LIFT.

Only if the piecewise linear method is used for calculation of spanwise variation of vorticity. For each of K strips in J = LIFSEC lifting sections:

$K, (D(I,J), E(I,J), F(I,J), I=1, K)$

where D, E, F are D_k, E_k, F_k of equation 7.11.5 of reference 3.

KFLOW Number of lifting strips

KONTRL Number of on-body source elements (not including ignored, wake, and extra strip elements)

COMSIG Combined source densities (ref. 3 eq. 7.13.1)
(KONTRL)

B(KFLOW) Vortex strength per unit length

3. Peripheral Storage

In addition to the flow field summary file (unit FLSUM) and the flow field file (unit FLOWF) several internal files are needed for the flow field calculation. Subroutine FLOW used eleven units for scratch storage. All data stored on these units are in binary format. In the following, use of each unit is considered only in terms of the maximum number of data words (numbers) and record lengths that would be stored on it. The following variables are defined to aid in this:

KONTRL	Number of quadrilateral elements, not including those generated by symmetry, ignored, in the wake and in extra strips.
KUTTA	Points defined by input cards no. 13 and 14 at which the Kutta condition is to be applied. (KUTTA > 0 only if the flow tangency option is exercised.)
NOFF	Number of off-body points at which velocity is to be calculated as defined by input cards no. 15.
NON	KONTRL + KUTTA + NOFF
IATAACK	Number of lifting strips, not counting extra strips, nor those generated by symmetry.
NFLOW	KFLOW + IATAACK

Unit 3: NFLOW records each consisting of 3 x NON numbers

Unit 4: There is a record of 29 numbers for each nonlifting quadrilateral element

plus

There is a record of 57 numbers for each lifting quadrilateral element (including ignored, wake, and extra strip elements)

plus

A one word record for each section of elements

Unit 8: The larger of

Two records each of length 3 x NON numbers or

NFLOW records each of length $6 \times \text{KFLOW}$ numbers or

KONTRL records each of length KUTTA numbers

Unit 9: KONTRL records of maximum length $\text{KONTRL} + 1$ numbers

Unit 10: KONTRL records of maximum length $\text{KONTRL} + 1$ numbers

Unit 11: $1/2$ KONTRL records each of length $3 \times \text{NON}$ numbers

Unit 12: $1/2$ KONTRL records each of length $3 \times \text{NON}$ numbers

Unit 13: The larger of

$2 \times \text{KONTRL}$ records each of length $3 \times \text{NON}$ numbers or

KONTRL records of maximum length $\text{KONTRL} + \text{NFLOW} + 1$ numbers

Unit 14: The larger of

KFLOW records each of length $3 \times \text{NON}$ numbers or

KONTRL records of maximum length $\text{KONTRL} + 1$ numbers

Unit 15: The larger of

KFLOW records each of length $3 \times \text{NON}$ numbers or

KONTRL records of maximum length $\text{KONTRL} + \text{NFLOW} + 1$ numbers

4. Variable Array Dimensioning

Subroutine FLOW incorporates variable dimensioning so that the program can be resized to fit different sized problems and computers. The calculation and storage of the flow field account for almost all storage required by LEWICE3D and hence are the only areas where variable dimensioning is used. To resize the problem the variables affected by the following dimension sizes must be resized in the main program along with the dimension sizes located in the data statement in the main program. The following description of the variable array sizes has been taken from reference 4. Minimum values for the variable dimension parameters are given where these numbers are not effected by symmetry.

LFSX Number of lifting sections

NL2X $\text{NSLX} + 2$

NOBX	Total number of lifting strips, not counting extra strips
NONX	Number of on-body elements in the flow (not counting ignored, wake, and extra strip elements) plus Kutta points defined by input (flow tangency option only) plus off body points (cards 15)
NSEX	Total number of sections (lifting plus nonlifting)
NSLX	Maximum number of lifting strips in any lifting section (including extra strips if input)
NSTX	Total number of strips (i.e., n-lines; lifting plus nonlifting plus extra strips)
NWAX	Similar to 2 x (number of on-body quadrilateral elements in the flow (see NONX) plus the number of onset flows)
	and
	Cube of the number of lifting strips (not counting extra strips: i.e. NOBX**3) if the pressure equality Kutta condition options is selected.
N2BX	2 x NOBX

D. Subroutine SETFLO

1. General Discussion

The module SETFLO reads the flow field generated by the Hess-Smith code (unit FLOWF). This subroutine is always executed and hence a flow field is required on unit (FLOWF).

1. Printed Output

SETLFLO output is limited to summary information about the flow field being read. This information is self explanatory and is written to units OUTPUT and JOBSUM.

E. Subroutine BETAC

1. General Discussion

The module BETAC drives the trajectory work used in calculating the local collection efficiency at each station of interest. This subroutine is optional (IRUN=2-10, NAMELIST TRAJ) and controls all the trajectory work (fig. 6). This subroutine calculates tangent and impact trajectories at the station of interest. The impact trajectory information is then used in the collection efficiency

calculation. If module BSTREM or LEWICE2D are to be executed then the collection efficiency information is required and BETAC must be executed.

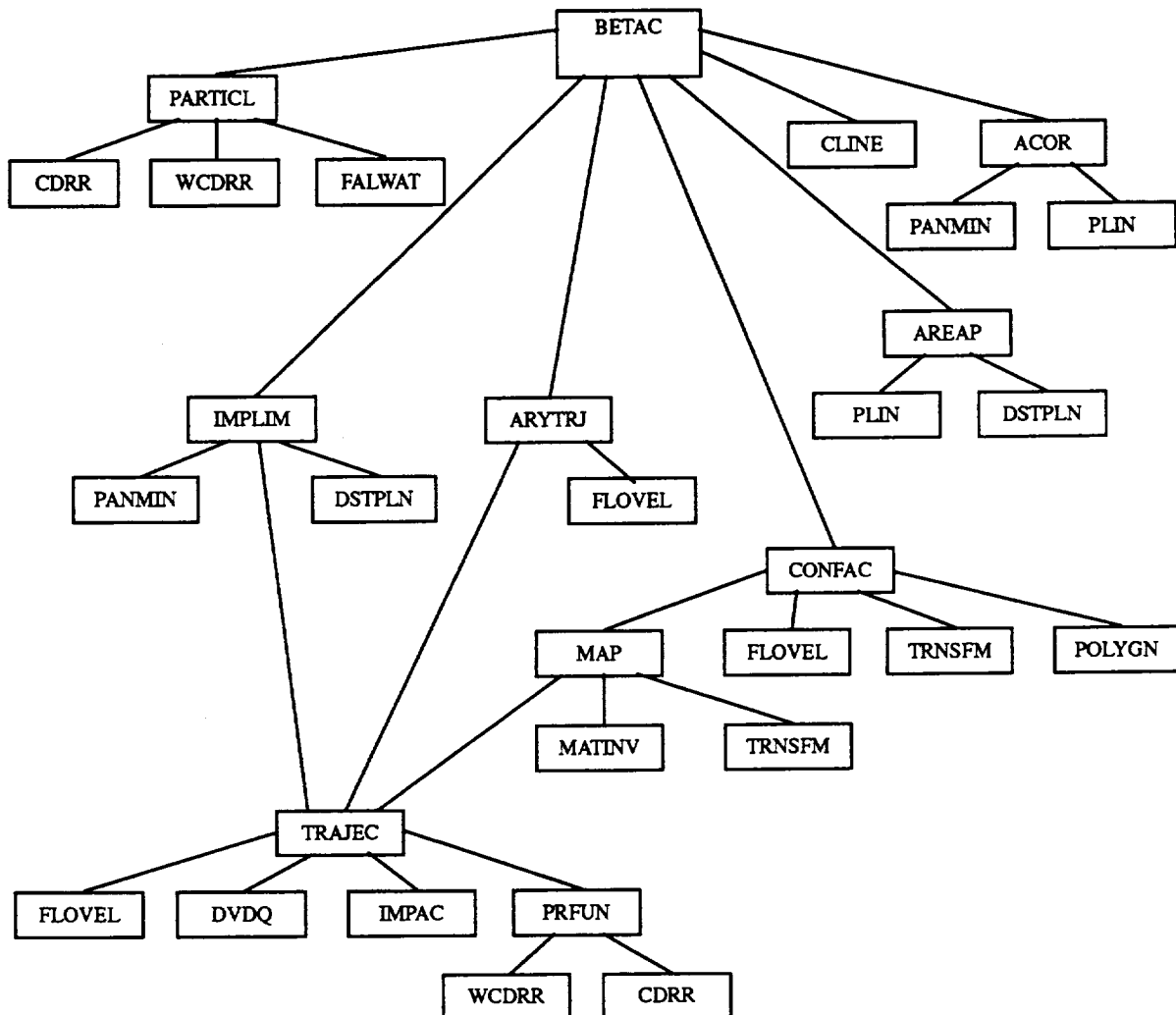

Figure 6. - BETAC segmentation tree structure.

a. Search For Upstream Particle Release Points

BETAC's first step toward the calculation of collection efficiency is to determine the upstream release points for trajectories that pass through the area of interest (fig. 7). There will be one release point calculated for each point specified at the section of interest (i.e. if NPSEC=2 then 2 upstream release points will be calculated; if NPSEC=4, then 4 upstream points will be calculated). These upstream release points (XSCI, YSCI, ZSCI) correspond to trajectories that will pass through the points defining the section of interest (XSEC, YSEC, ZSEC). The program CONFAC

developed by Normant (ref. 5) and put into subroutine form here is used to determine each of the upstream points.

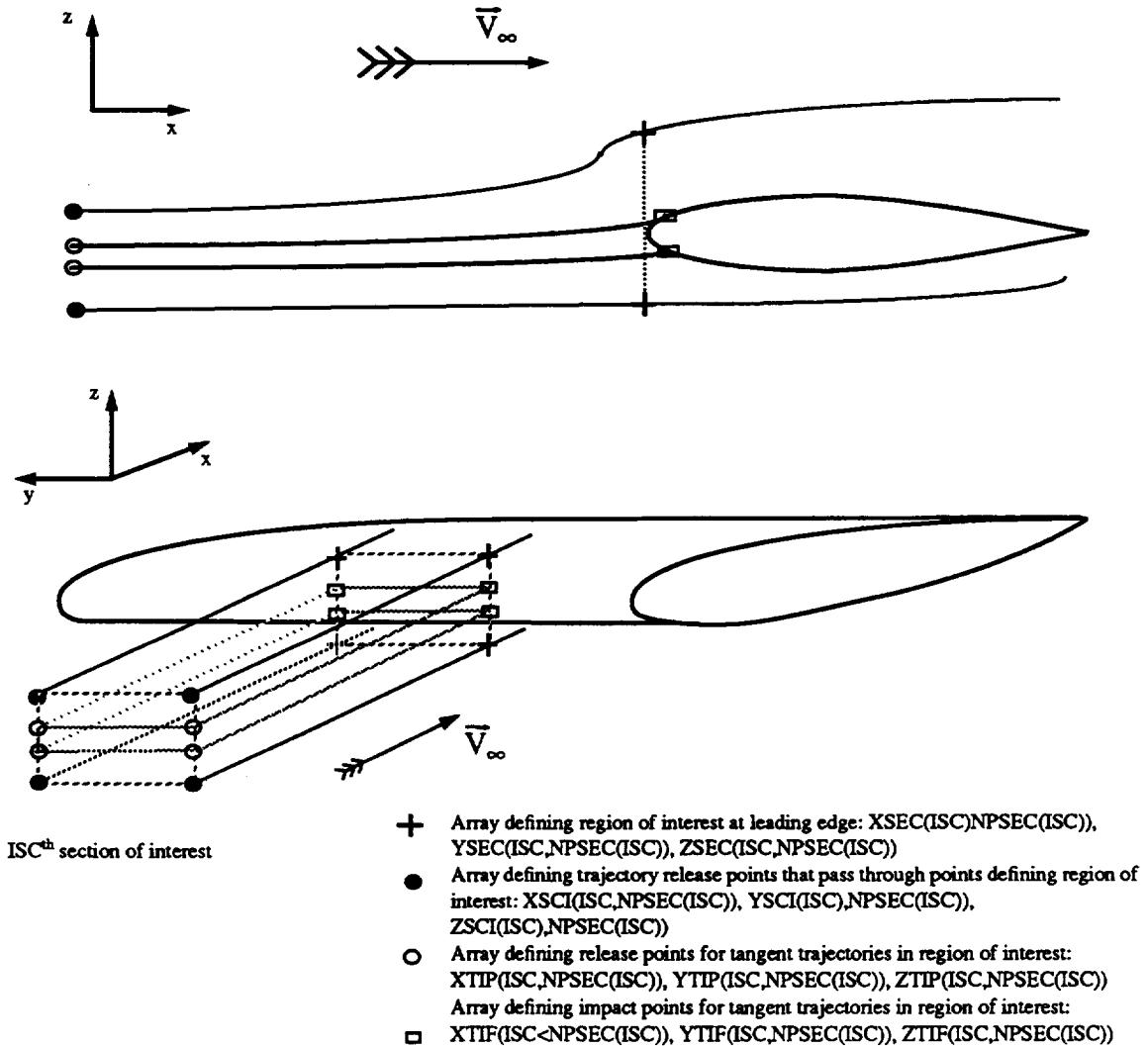

Figure 7. - Illustration of tangent trajectory search arrays.

Program CONFAC is described in detail in reference 5 and will be covered only briefly here. CONFAC is an iterative procedure which finds a trajectory that passes within $RW \cdot TOL$ of the specified target point (XSEC, YSEC, ZSEC). Subroutine MAP controls the iteration and uses subroutine TRAJEC for the calculation of individual trajectories. If convergence has not been reached in 50 iterations then CONFAC will continue with the next upstream point. If one or more failures occur during the search for each of the upstream points then the program will terminate.

b. Search For Tangent Trajectories

The second step toward calculating the collection efficiency at a section of interest is to determine the tangent trajectories. These are limiting trajectories that impact. Trajectories released between corresponding upper and lower tangent trajectories will impact the body. Those released outside the tangent trajectories will miss the body. There will be one tangent trajectory for every point of interest on the body (i.e. if NPSEC=2 then there will be 2 tangent trajectories, an upper and a lower. If NPSEC =4, then there will be 4 tangent trajectories, two upper and two lower). The tangent trajectories are found by searching for the proper release points along the lines formed by the upstream release points XSCI, YSCI, ZSCI. For NPSEC=2 there will be one line. For NPSEC=4 there will be 2 lines. Each line is searched in both directions to determine the upper and lower tangent trajectories. The tangent trajectory search is handled by the subroutine IMPLIM.

Subroutine IMPLIM determines tangent trajectories at the section of interest. Subroutine IMPLIM is based on the 2D tangent trajectory search routine used in LEWICE (ref. 7). Subroutine IMPLIM requires the input of specified lines (in this case the lines are formed by alternating values of XSCI, YSCI, ZSCI), an initial start point on the specified line (in this case alternating points XSCI, YSCI, ZSCI), and the search tolerance DFINE. The algorithm initiates trajectories along the specified line midway between the most current "hit" trajectory and the most current "miss" trajectory. If the trajectory impacts the body it becomes the current "hit" trajectory. If it misses the body it becomes the current "miss" trajectory. The algorithm terminates the search when the distance between the initial start points of the current "hit" and "miss" trajectories is less than DFINE. This current impacting trajectory is then the tangent trajectory and is denoted by its upstream release points XTIP, YTIP, ZTIP. If the subroutine fails to find an impacting trajectory after three steps then it will continue on with the next tangent search. If one or more failures occur during the tangent trajectory search at the section of interest then the program will terminate.

c. Calculation Of Impact Trajectories

The third step is to determine the matrix of release points for the trajectories to be used in the collection efficiency calculation. If NPSEC=2, then a string of NBR equi-spaced release points will be generated between the upper and lower tangent trajectory release points (XTIP, YTIP, ZTIP). If NPSEC=4, then a matrix of NBR x NBC trajectories release points will be determined. The rectangle formed by the four upstream tangent trajectory release points (XTIP, YTIP, ZTIP) is divided into NBC equi-spaced columns and NBR equi-spaced rows (fig. 8).

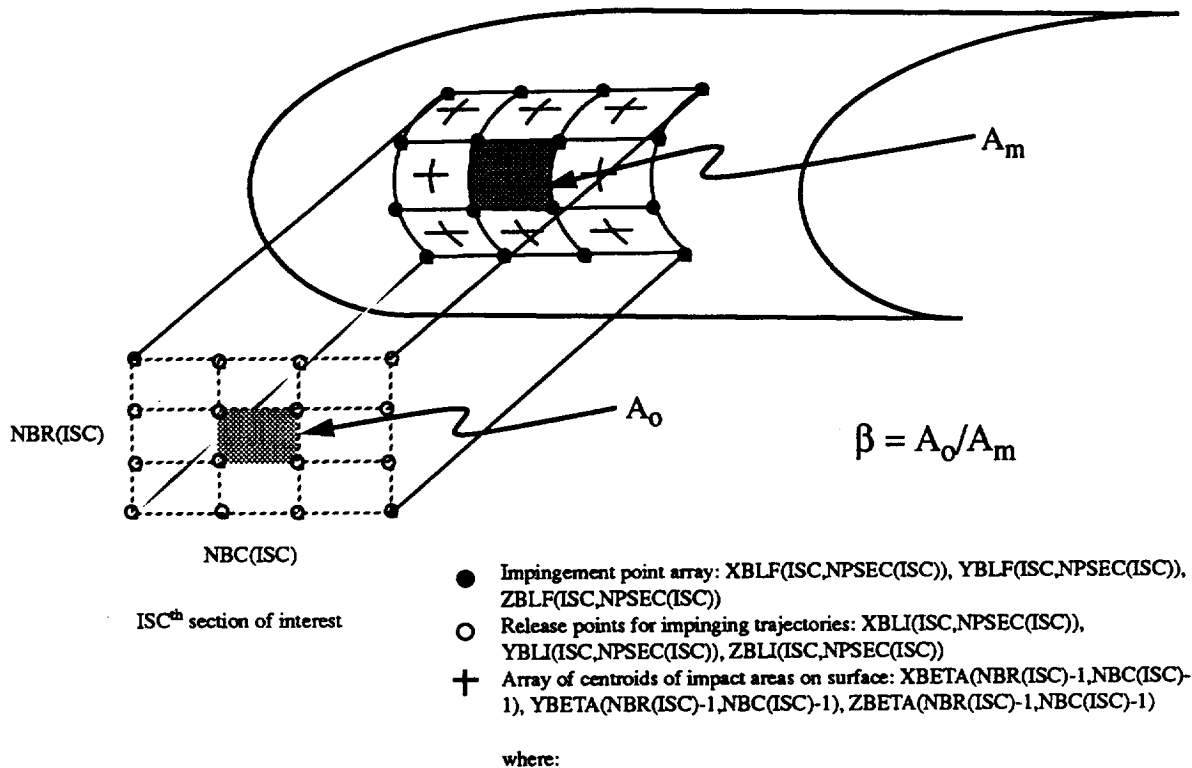

NBR(ISC) is the number of rows of trajectories to be released in impingement array for the ISCth section, NBC(ISC) is the number of columns of trajectories to be released in impingement array for the ISCth section.

Figure 8. - Illustration of starting point and impaction point arrays.

The fourth step involves calculating the trajectories for each of the release points generated in the above step. Subroutine ARYTRJ (ref. 5) is used to calculate the individual trajectories. The impact points corresponding to the release points are stored in arrays XBETA, YBETA, ZBETA for use in the calculation of collection efficiency.

d. Calculation Of Collection Efficiency

The fourth and final step involves the calculation of collection efficiency at the section of interest. Subroutine BETAC calculates the local collection efficiency in two different ways depending on the variable NPSEC. The first method (NPSEC = 4) uses a full 3D calculation for which a matrix of impact trajectories (NBC x NBR) is required. This method is to be used for areas where fully 3D flow is expected. The second method (NPSEC = 2) uses a 2D method in which a single string of NBR impact trajectories is required. This 2D method saves considerable computational time and is justifiable for cases where small spanwise variations in the flow field are expected throughout the section of interest.

The full 3D collection efficiency calculations are straightforward and are analogous to those of the 2D problem. 3D collection efficiency is defined as the ratio of the particle flux at the surface to the particle flux in the free stream. Or if we follow a group of particle trajectories to the surface, then the 3D collection efficiency is the ratio of the surface area to free stream area mapped out by the particles.

$$\beta(x_c) = A_o/A_m \quad \text{Eq. 1}$$

If the flux tube consists of four adjacent trajectories in the release matrix (fig.9) then the collection efficiency at the surface can be written where corrections for angle-of-attack and yaw have been made.

$$\beta(i,j) = (\cos\Psi \cdot \cos\alpha \cdot A_o(i,j)) / (A_m(i,j)) \quad \text{Eq. 2}$$

where the collection efficiency is said to be located at the center of the impact region mapped out by the four impacting particles. The angles Ψ and α refer to the sideslip and pitch angle of the geometry relative to the free stream flow vector (fig. 9). The areas $\bar{A}(i,j)$ and $A_m(i,j)$ are calculated using subroutine AREAP which calculates the area of an arbitrary polygon by dividing it into triangles and summing the areas of the individual triangles.

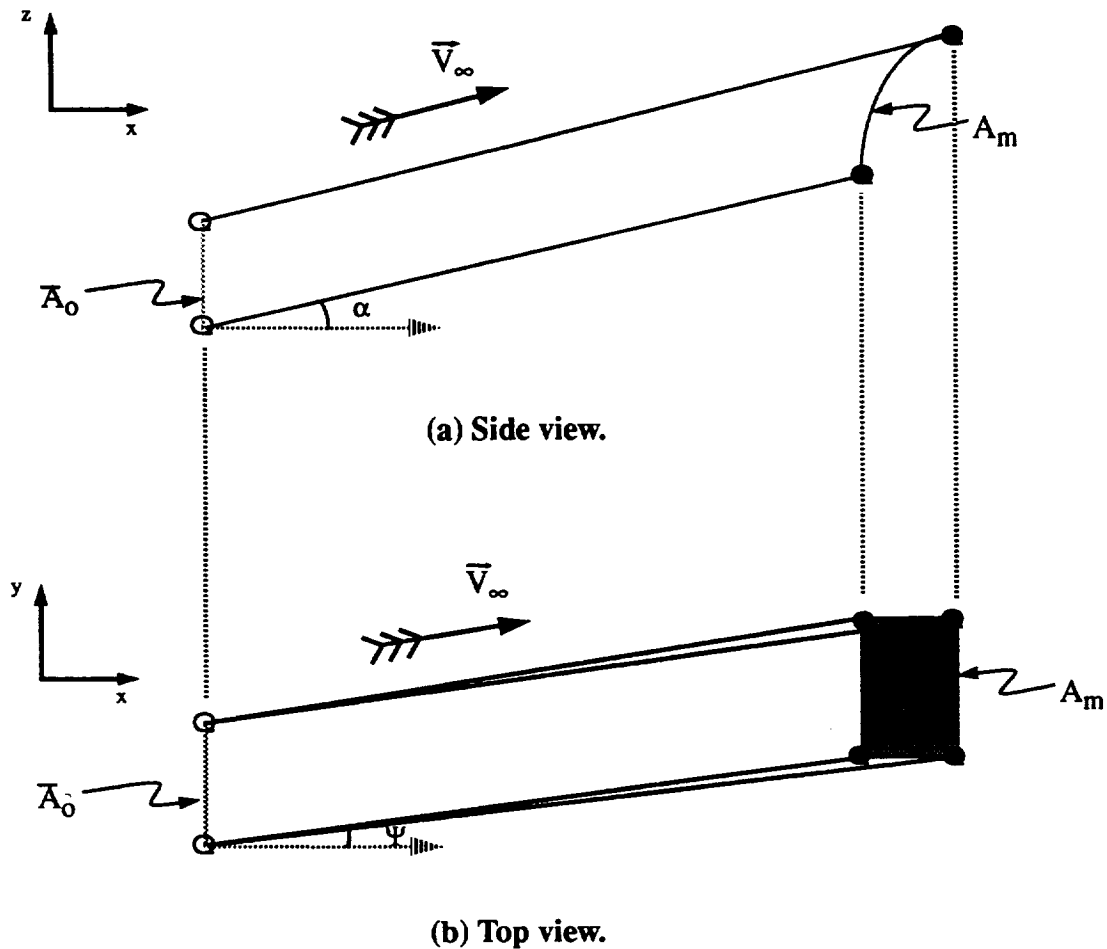

Figure 9. - Pitch and sideslip corrections for 3D collection efficiency calculation.

Calculation of collection efficiency using the “pseudo 2D” methods is similar to the 2D methods with several corrections. Corrections for angle-of-attack, yaw angle, sweep angle of surface and deformation of the flux tube are necessary (fig. 10). The resulting collection efficiency equation is then

$$\beta(i) = (\cos\psi \cdot \cos\alpha \cdot \cos\nu \cdot DS_o(i)) / (DS_m(i)) \quad \text{Eq. 3}$$

where the collection efficiency is said to occur at the center of the impacting points of the two trajectories. The distances $DS_o(i)$ and $DS_m(i)$ represent the distance between the upstream release point and the impact points respectively for two adjacent trajectories (fig. 10). As for the 3D case the angles α and ψ represent the pitch and sideslip angles, respectively. Angle ν represents the rotation angle of the droplet trajectory pair relative to the sweep of the leading edge of the airfoil.

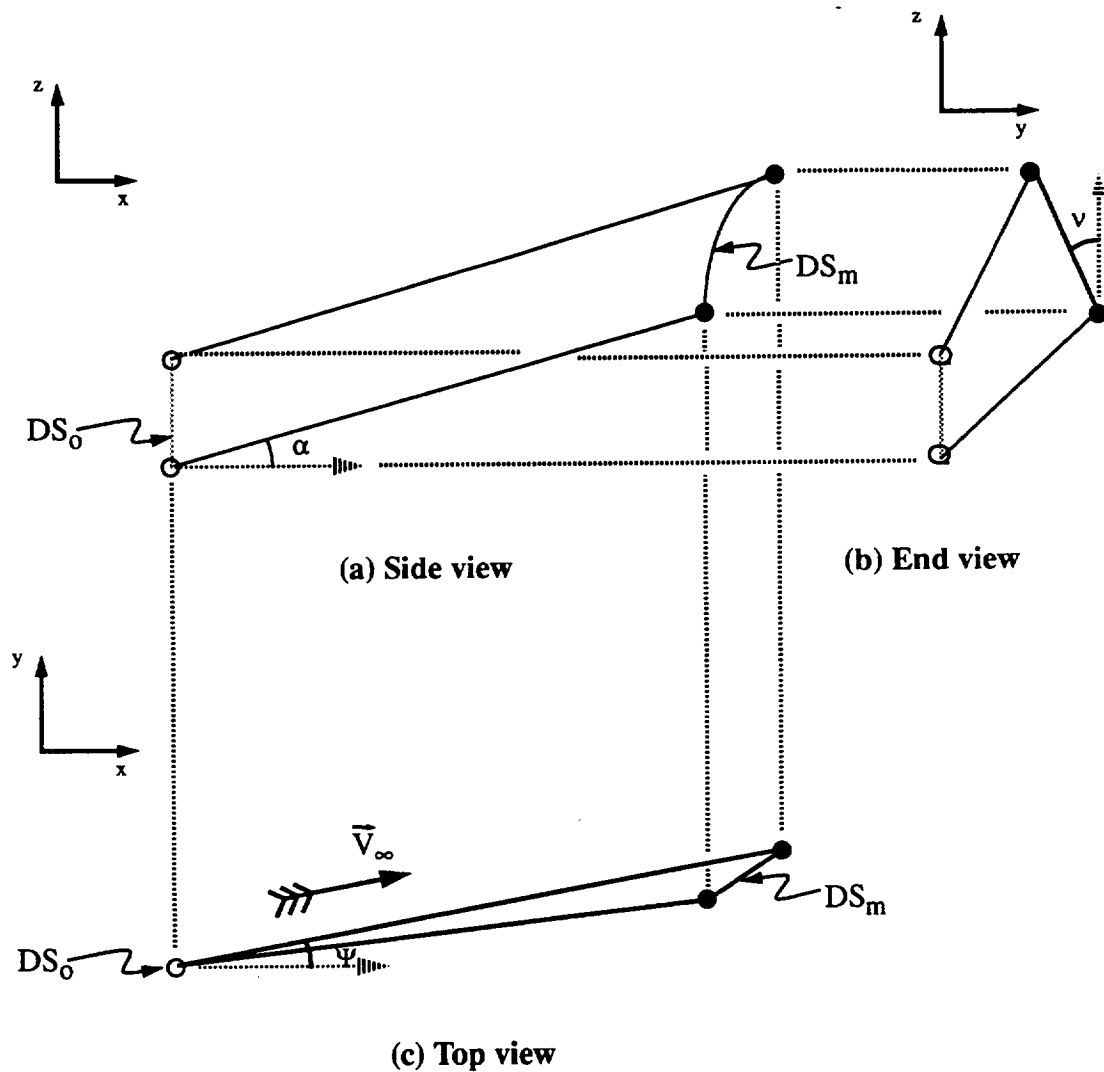

Figure 10. - Corrections for pitch, sideslip, and rotation for “quasi 2D” collection efficiency calculation.

2. Printed Output

BETAC output is written to several files and includes summary information about the trajectory calculation, trajectory coordinates, and several error messages.

Trajectory summary information includes various information about the CONFAC, TANTRA, and ARYTRJ runs and is written to units JOBSUM and OUTPUT. The information written to the files is self explanatory.

Trajectory coordinates along with other pertinent trajectory parameters are written in binary format to unit TEMP25. The information is output according to the output time step TPRINT and is in the following format (SR's CONFAC, TANTRA, and ARYTRJ)

IREC,(T(I),P1(I),P3(I),P5(I),P2(I),P4(I),P6(I),VX,VY,VZ,H,R,AC) I=1,IREC)

where:

IREC	Total number of cards output
T(I)	Integration time at the Ith output step
P1(I),P3(I),P5(I)	X,Y, Z components of the particle velocity respectively
P2(I),P4(I),P6(I)	X,Y,Z components of the particle acceleration respectively
VX,VY,VZ	X,Y,Z components of the flow field velocity respectively
H	Integration step size at the Ith output step
R	Reynolds number at the Ith output step
AC	Acceleration modulus at the Ith output step

Several error messages are written to units OUTPUT, JOBSUM. These messages along with an explanation and a possible solution are as follows.

- | | |
|-----------------|--|
| (a) Message: | OUTPUT TRAJECTORIES FROM SUBROUTINE CONFAC DOES NOT MATCH THE NUMBER REQUIRED. (SR BETAC) |
| Cause of error: | Failure to find a trajectory that passes within a given tolerance (TOL) for one of the target points at the section of interest (XSEC, YSEC, ZSEC). |
| Action: | Increase error tolerance (TOL), move section of interests points farther from body (i.e. XSEC, YSEC, ZSEC) or increase the trajectory count limit for the CONFAC search (ILIM in data statement in SR MAP) |
| (b) Message: | OUTPUT TRAJECTORIES FROM SUBROUTINE TANTRA DOES NOT MATCH THE NUMBER REQUIRED. (SR BETAC) |
| Cause of error: | Failure to find a tangent trajectory for one of the impingement limits at the section of interest (XTIP, YTIP, ZTIP). |
| Action: | Increase the tangent trajectory search step sizes (DCOR,DFINE) or increase the trajectory count limit for the TANTRA search (KTLIM in data statement in SR TANTRA) |

F. Subroutine STREM3D

1. General Discussion

The module STREM3D determines the streamline at the station of interest. The module uses a RUNGE-KUTTA integration scheme to calculate the 3D streamlines. Figure 11 shows a schematic of the job stream for STREM3D. STREM3D also generates pressure coefficient and velocity information at each of the streamlines points. This module is optional (IRUN=1,5,7,9; and ISTRF=0; NAMELIST TRAJ). If module BSTREM or LEWICE2D are to be executed then streamline information is required and either STREM3D or STREM2D must be executed.

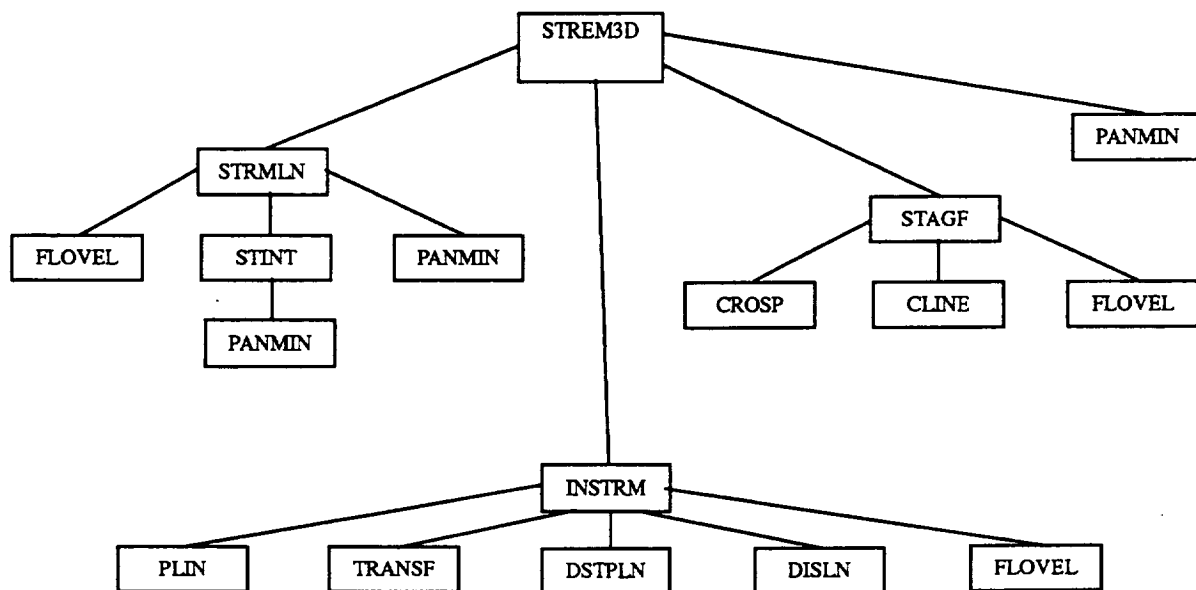

Figure 11. - STREM3D segmentation tree structure.

Four steps are involved in determining the 3D streamline: determination of the local stagnation point, integration of the upper surface streamline, integration of the lower surface streamline, and projection of the upper and lower surface streamlines onto the body.

b. Search For Stagnation Zone

A marching procedure is used to determine the stagnation zone. This algorithm steps towards the body with a step size of H. At each point a vertical scan of velocities is made. A dot product is made from consecutive velocities along the scan line. When the dot product reaches a

minimum along the scan line, the value is stored and compared to a criterion, VCRIT (currently VCRIT = .5). If the value is less than the criterion, then the stagnation point has been found and the current scan line points (XL, YL, ZL) and the points where the dot product reached a minimum value are stored (ISUP, ISLO). The points ISUP and ISLO are the points in the scan line arrays (XL, YL, ZL) where the upper and lower streamlines' integration will initiate, respectively. If the criterion is not met at the current scan line then the procedure steps towards the body and repeats the above process. If the algorithm marches to the leading edge without meeting the criterion, VCRIT, then a warning message is printed and the stagnation points (ISUP, ISLO) are set to the values where the minimum dot product occurs for the current scan line. The above procedure essentially searches for the point near the leading edge where the velocity vector divergence (measured by the dot product of consecutive velocities along the scan line) is the greatest. This point should be the stagnation zone and streamlines initiated above this point (ISUP) should follow the upper surface, while streamlines initiated below this point should follow the lower surface.

b. Calculation Of Upper and Lower Streamlines

Once the stagnation point has been found, the upper and lower surface streamlines can be determined. Off-body streamlines are used because velocity gradients on the panel edges make the integration of on-body streamlines difficult. The streamlines are integrated using a Runge-Kutta 4th order integration scheme with variable step size from points located on the scan line stored in the previous step (i.e. XL, YL, ZL). The upper streamline is integrated from the point ISUP in the scan line array. If problems occur at any time during the integration (i.e. the streamline penetrates the body or the step size is too small) the streamline calculation will be restarted from the next point in the scan line array (i.e. ISUP = ISUP + 1). The above process is repeated until a streamline is integrated to X = XSTOP with no problems. If failure to integrate a "good" streamline occurs for ISUP = NPTS (where NPTS is the number of points in the scan line array) then the program will terminate. After the upper surface streamline has been found, the lower streamline search begins. The lower streamline integration is initiated from the point ISLO in the scan line arrays. As for the upper streamline, the lower streamline is integrated until either a X=XSTOP is reached or until a problem arises. If a problem occurs then the streamline is restarted from the next point on the scan line (i.e. ISLO = ISLO - 1). If ISLO drops below 1 during a restart then the procedure will terminate.

c. Projection Of Streamlines Onto Surface

The last step is to project the streamlines onto the body. That is, the off-body integrated streamlines are projected onto the body in a surface normal direction to produce a streamline which has points lying on the panel edges. Projecting the streamline onto the body is done to allow easier geometry modifications in later calculations

To project the streamline onto the body we must first find the portion of the body where the streamline is located. This is done by searching for the panel which is closest to the centroid of the current section of interest (XC, YC, ZC). The lifting strip that contains the panel is then used for the on-body projection.

Once the local lifting strip has been found, we can construct the on-body points. There will

be NSTREM points in the on-body streamline which correspond to one more than the number of panels in the lifting strip. Each point on the on-body streamline will lie upon a panel edge connecting n-lines in the strip. Hence if there are NPTS panels there will be NPTS+1 points in the N-lines and hence NPTS + 1 points in the on-body streamline.

To determine the on-body points corresponding to each panel edge in the strip, we first must calculate several parameters for each edge line in the strip: the surface normal of the panel edge (XN, YN, ZN), a line containing the panel edge (A, B), and a plane with the normal of the panel edge which contains the panel edge (PLN). For the first and last edge line, the surface normal is the surface normal for the first and last panel respectively. For internal edges, the surface normal is taken as the average of the two surface normals from the panels that form the edge. The line containing the panel edge is formed from the corresponding points on the panel edge. The edge normal plane is determined from the panel edge surface normal and from a panel corner point on the panel edge line.

We can now construct the on-body points. Each point on the upper and lower integrated streamlines is projected onto the panel edge plane (PLN) using subroutine TRNSF (these points are stored in arrays XNEW, YNEW, ZNEW). The algorithm then searches for the two closest points in XNEW, YNEW, ZNEW to the line formed by the panel edge (A, B). A line is then formed from the two points (A2, B2) and the intersection between the two lines (A, B and A2, B2) is found. This point of intersection (PIN) is then the on-body point from the current edge line. This procedure is repeated for each of the panel edge lines in the lifting strip.

2. Printed Output

Output from STREAM3D is written to several output files (JOBSUM, OUTPUT) and includes summary information about the streamline integration and several error messages. The summary information includes coordinates, surface distances (measured from stagnation zone where positive surface distance denotes lower surface and negative surface distance denotes upper surface), pressure coefficients, and surface normals for each point on the streamline. The following error messages which can occur are explained with possible solutions.

Message:	STOP IN SUBROUTINE STREAM, ISUP = XXX or STOP IN SUBROUTINE STREAM, ISLO = XXX
Cause of error:	Failure to find an upper streamline or lower streamline along the line of points (XL, YL, ZL). During the search iteration the release point for the streamline (ISLO or ISUP) has reached the upper or lower bound of the arrays XL, YL, ZL (i.e ISUP = 25 or ISLO =1).
Action:	Increase the distance between the body and the section of interest (XSEC, YSEC, ZSEC)

G. Subroutine STREM2D

1. General Discussion

The module STREM2D determines a 'pseudo' streamline at the station of interest. Figure 12 shows a schematic of job stream for STREM2D. The 'pseudo' streamline is determined as the intersection between the surface geometry and a plane input by the user (PLNST(I), I=1,4; NAMELIST TRAJ). This essentially generates a 2D cut along the surface. This 2D streamline can be used for generating data (e.g. pressure coefficient, collection efficiency, heat transfer coefficient) for swept and unswept comparisons or for evaluating the traditional quasi-3D icing calculation (i.e. calculating swept 3D cases by using 2D calculations along planes normal to the leading edge). This module is optional (IRUN=1,5,7,9: and ISTRF=1: NAMELIST TRAJ). If module BSTREM or LEWICE2D are to be executed then streamline information is required and either STREM3D or STREM2D must be executed.

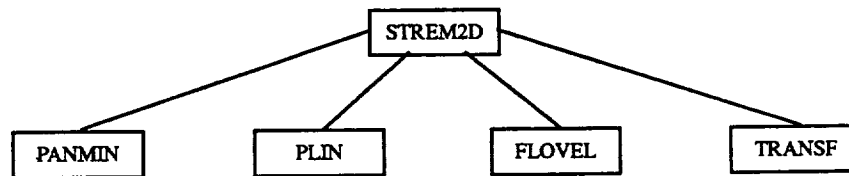

Figure 12. - STREM2D segmentation tree structure.

The first step in determining the 2D streamline is to find the lifting strip associated with the section of interest. As for the 3D streamline case, this strip is the one associated with the closest panel to the section of interest.

The next step is to determine where the specified plane intersects the local lifting strip. The points making up the 2D streamline are essentially the points where the panel edge lines (m-lines in the strip) intersect the plane. There will be one point on the 2D streamline for every m-line in the strip. This number of points in the 2D streamline then corresponds to the number of points in the N-lines for the strip or to the number of panels plus one.

Each point on the 2D streamline is constructed from an m-line and the specified plane. The panel edge lines (A, B) are constructed from the 2 corner points of the panel forming the edge line (P1, P2). The intersection of the edge line and the plane is calculated in subroutine PINT. This point then is the 2D streamline point. This procedure is repeated for every point in the N-line.

2. Printed Output

STREM2D output consists of coordinates, surface distances (measured from stagnation zone where positive surface distance denotes lower surface and negative surface distance denotes upper surface), pressure coefficients, and surface normals along the streamline and is written to units JOBSUM and OUTPUT.

H. Subroutine BSTREM

1. General Discussion

The module BSTREM interpolates the surface collection efficiencies generated by module BETAC onto the streamline generated in STREM2D or STREM3D. Figure 13 provides a schematic of the BSTREM algorithm. This module is optional (IRUN=5,7,9: NAMELIST TRAJ). If LEWICE2D is to be executed, then collection efficiencies along the streamlines are required and BSTREM must be executed.

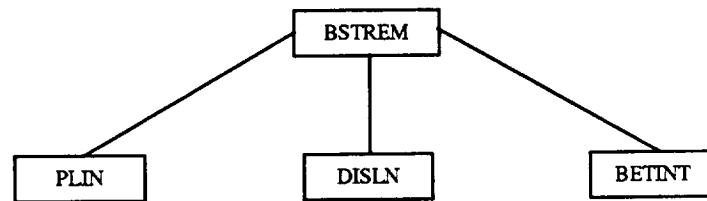

Figure 13. - BSTREM segmentation tree structure.

Subroutine BSTREM calculates the collection efficiency along the streamline from the surface impingement data in two different ways depending on the value of NPSEC. If NPSEC = 4 then an interpolation for the streamline points is made from the surface collection efficiency information. If NPSEC= 2, then an extrapolation of the surface collection efficiency is made onto the streamline points.

The first step in making the 3D interpolation (NPSEC = 4) is to determine the location of the streamline points relative to the matrix of surface collection efficiency points. For each point in the surface streamline, a search is made to determine in which collection efficiency cell the point lies (fig. 14). If the point does not lie in any of the cells, then the collection efficiency for that point is set to zero. This means care must be taken in setting the width of our section of interest. The spanwise width of the section of interest must cover the spanwise range of the streamline in its entirety within the impingement local impingement limits.

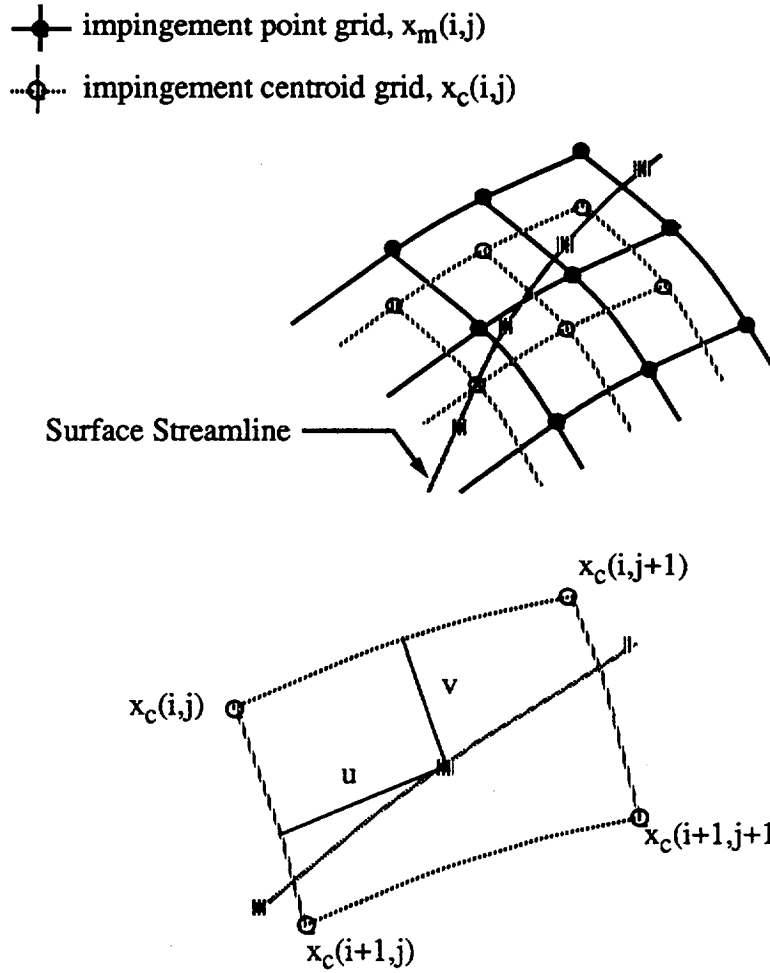

Figure 14. - Collection efficiency interpolation onto surface.

The interpolation procedure used when NPSEC = 4 is basically that described by Kim (ref. 8) in his 3D trajectory code paper. Given a point on the surface which lies amid the matrix of surface collection efficiencies, we have the following interpolation scheme for the collection efficiency at that point.:

$$\begin{aligned}
 \beta(x_s) = & \beta(x_c(i+1, j+1)) \cdot u \cdot v + \beta(x_c(i, j+1)) \cdot u \cdot (1-v) + \\
 & \beta(x_c(i, j)) \cdot (1-u) \cdot (1-v) + \beta(x_c(i+1, j)) \cdot (1-u) \cdot v
 \end{aligned}
 \tag{Eq. 4}$$

where:

$$\begin{aligned}
 u &= \vec{X}_s \cdot \vec{X}_j \\
 v &= \vec{X}_s \cdot \vec{X}_i
 \end{aligned}
 \tag{Eq. 5}$$

The method employed when $NPSEC = 2$ is an extrapolation technique based on the assumption that there is no spanwise variation in collection efficiency. Alternatively, the method assumes that surface lines running parallel to the leading edge are lines of constant collection efficiency. For each point on the streamline, a test is made to determine which two iso-lines of collection efficiency the point lies between. If the point is outside of the impingement limits, then the two iso-lines will be zero and the collection efficiency will be set to zero. To determine which iso-lines the streamline point lies between, we first form a line parallel to the surface which goes through the streamline point. This line (A, B) is formed from the slope of the local panel edge (ATRAN) and from the point on the streamline (P1). We then loop through the collection efficiency surface points searching for the two closest points to this line (P3, P4), and form a line between these two points (A2,B2). The minimum distance between the lines and the points where this minimum occurs for each of the lines is then calculated (PIN1, PIN2). If the point (PIN1) lies outside of the endpoints of the line segment (A2, B2), then the point lies outside of the impingement limits and its impingement efficiency is zero. If the point lies within the line segment, then a linear interpolation of collection efficiency from the collection efficiencies at the segment endpoints is made. This collection efficiency is then the collection efficiency for the streamline point.

2. Printed Output

BSTREM output consists of streamline coordinates, surface distances (measured from stagnation zone where positive surface distance denotes lower surface and negative surface distance denotes upper surface), pressure coefficients, surface normals, trajectory tangents and collection efficiency information along the streamline and is written to units JOBSUM and OUTPUT.

I. Subroutine LEWICE2D

1. General Discussion

The module LEWICE2D calculates the ice shape at the section of interest using the collection efficiency and pressure coefficient information generated above. The methodology of the ice accretion is basically that of the 2D LEWICE calculation expanded to three dimensions. Figure 15 shows a breakdown of the job stream for LEWICE2D. The ice may be grown either in the surface normal direction or in the trajectory tangent direction (see subroutine NEWPTS). If LEWICE2D is to be executed, then collection efficiency and pressure coefficient information is needed along the streamline and hence BETAC, STREM2D or STREM3D, and BSTREM must be executed.

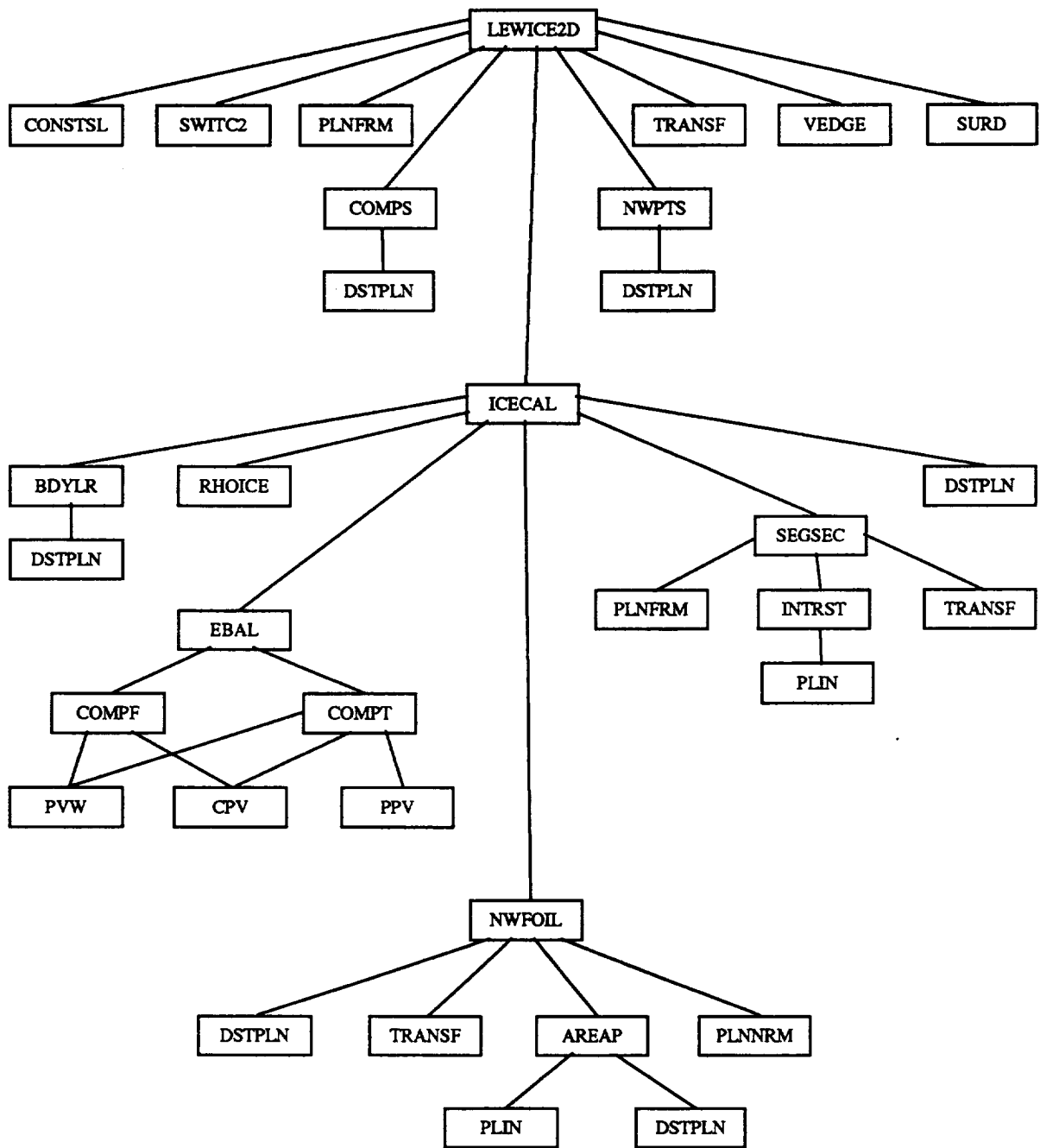

Figure 15. - LEWICE2D segmentation tree structure.

The ice accretion process consists of the deposition of super-cooled water droplets on an aerodynamic surface and the associated mass and energy exchange processes which result in the growth of ice on that surface. That process was first modeled by Tribus (ref. 9) and later developed into the model currently used in LEWICE, by Messinger (ref. 10). The Messinger model is also used in this code and is applied along streamlines, as calculated by the potential flow portion of the code. This chapter describes the Messinger model, the application of that model along streamlines, and the input and output files used by these subroutines.

a. Modeling The Ice Growth Process

The Messinger model of ice growth is based on the premise that all water impinging on the surface of interest exchanges energy with the surface and surrounding environment, resulting in freezing of some fraction of the incoming water and the remaining water running back along the surface. This model of ice growth on a surface exposed to an icing cloud is depicted in figure 16, showing the relevant mass and energy exchange processes.

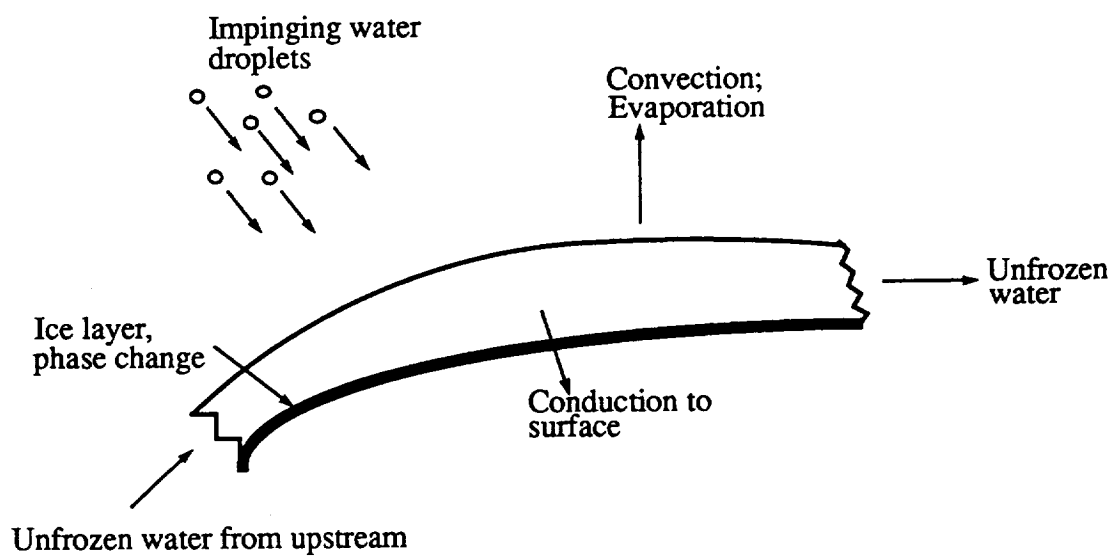

Figure 16. - Ice growth on a surface

The ice growth is modeled by dividing the surface into control volumes, along streamlines determined from the potential flow analysis, and performing a mass and energy balance on each control volume. The control volume extends from the ice-water interface out to beyond the boundary layer. Evaluation of the control volumes is started at the stagnation point and marches along the upper and lower surfaces to the trailing edge. The mass and energy balances at each station are considered quasi-steady processes. The ice growth is thus modeled as a series of steady-state processes with the duration of each step and the number of steps determined by the user.

The mass balance, depicted in figure 17, is described by the following equation

$$\dot{m}_c + \dot{m}_{r_{in}} - \dot{m}_e - \dot{m}_{r_{out}} = \dot{m}_i \quad \text{Eq. 6}$$

where \dot{m}_c is mass flow rate of incoming water, $\dot{m}_{r_{in}}$ is the mass flow rate of runback water from the previous control volume, \dot{m}_e is the mass flow rate of evaporated water, $\dot{m}_{r_{out}}$ is the mass flow rate of water running back to the next control volume, and \dot{m}_i is the mass flow rate of water leaving the control volume due to freeze-out.

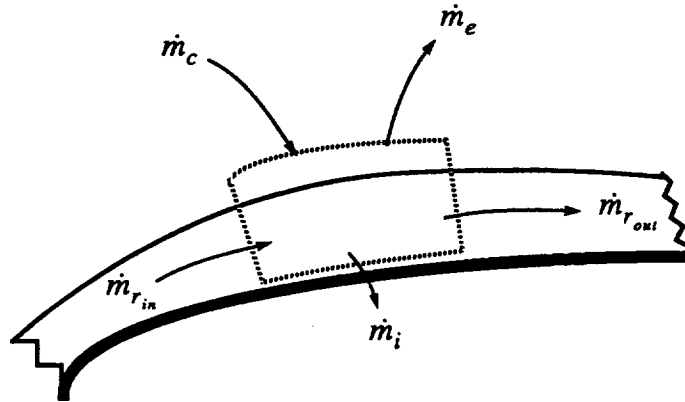

Figure 17. - Mass balance control volume

In this mass balance, the incoming water, incoming runback water, and evaporated water flow rate are previously calculated quantities. The amount of water changing phase to ice is determined from the energy balance and any remaining water is considered to move into the next control volume. The value of $\dot{m}_{r_{in}}$ is set to zero at the stagnation point, as this is the start of the marching process for both the upper and lower surfaces.

The energy balance is handled in a similar manner and is depicted in figure 18.

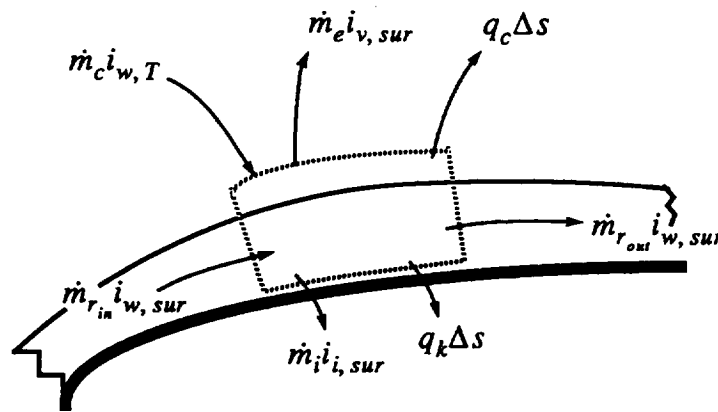

Figure 18. - Energy balance control volume

The equation describing the control volume energy balance is

$$\begin{aligned} & \dot{m}_c i_{w,T} + \dot{m}_{r_{in}} i_{w,sur(i-1)} \\ = & (\dot{m}_e i_{v,sur} + \dot{m}_{r_{out}} i_{w,sur} + \dot{m}_i i_{i,sur} + q_c \Delta s + q_k \Delta s) \end{aligned} \quad \text{Eq. 7}$$

where $i_{w,T}$ is the stagnation enthalpy of the incoming water droplets, $i_{w,sur(i-1)}$ is the enthalpy of the water flowing into the control volume from upstream, $i_{v,sur}$ is the enthalpy of the vapor leaving the control volume due to evaporation, $i_{w,sur}$ is the enthalpy of the water running back to the next control volume, $i_{i,sur}$ is the enthalpy of the ice leaving the control volume, q_c is the heat transfer due to convection, and q_k is the heat transfer due to conduction.

The incoming energy due to water droplet impingement and runback are calculated from known information. The energy leaving the control volume due to evaporation and convection can be calculated independently. The heat transfer due to conduction is not considered in this analysis, as the ice layer is considered to act as an insulating surface. This leaves the energy loss due to freeze-out and the energy leaving the control volume due to runback as unknowns. In particular, the mass flow rates for these two terms are unknown, as was the case for the mass balance. This leaves two equations and two unknowns and the system can be solved. The details of the evaluation of each of the terms in the energy equation can be found in appendix A of the LEWICE Users Manual (ref. 7). A useful concept for evaluation of the nature of the ice accretion being calculated is the freezing fraction. This is the fraction of the total water coming into the control volume that changes phase to ice. The equation defining freezing fraction is

$$f = \frac{\dot{m}_i}{\dot{m}_c + \dot{m}_{r_{in}}} \quad \text{Eq. 8}$$

This term can also be used to simplify the evaluation of the energy balance.

The convection heat transfer term plays an important role in the LEWICE3D energy balance. It is through this term that the aerodynamics and the roughness levels can influence the development of the ice accretion. Currently, the convection heat transfer is determined from an evaluation of the boundary layer growth on the surface, using an integral boundary layer method. The pressure distribution determined by the potential flow code is used as input to the boundary layer calculation. The boundary layer calculation determines the displacement thickness and the momentum thickness. The Reynold's analogy is used to determine the heat transfer coefficient. Roughness is accounted for by a correlation developed by Ruff. (ref. 7) The complete description of the integral boundary layer calculation is found in appendix B of the LEWICE Users Manual (ref. 7).

Expanding the terms in the energy equation as described in the LEWICE manual and combining Eqs.7 and 8 yields the following form of the energy equation

$$\begin{aligned}
& \dot{m}_c \left[c_{p_{w,s}} (T_s - 273.15) + \frac{V_\infty^2}{2} \right] \\
& + \dot{m}_{r_{in}} \left[c_{p_{w,sur(i-1)}} (T_{sur(i-1)} - 273.15) \right] + q_k \Delta s \\
& = m_e \left[c_{p_{w,sur}} (T_{sur} - 273.15) + L_v \right] \\
& + [(1-f) (\dot{m}_c + \dot{m}_{r_{in}}) - \dot{m}_e] c_{p_{w,sur}} (T_{sur} - 273.15) \\
& + f (\dot{m}_c - \dot{m}_{r_{in}}) \left[c_{p_{i,sur}} (T_{sur} - 273.15) - L_f \right] \\
& + h_c \left[T_{sur} - T_e - \frac{r_c V_e^2}{2c_{p_a}} \right] \Delta s
\end{aligned} \tag{Eq. 9}$$

b. Ice Growth Along Streamlines

The application of this ice growth model in two dimensions is straightforward in the sense that the flow direction of runback water is unambiguous. In three dimensions, the flow direction of water out of a control volume is not so easily determined. The most rigorous approach would be to solve the air-water flow interaction problem, including the possibility of flow over large roughness elements. In this case, considerable computational effort would be required beyond the already significant effort of calculating the flow field, droplet trajectories, and ice growth. As such, some degree of approximation is appropriate in order to develop a tool which can be useful and not require more computational effort than necessary.

One alternative is to calculate the boundary layer development over the entire three dimensional surface. This approach requires significant computational expenditure. The approach taken for this code is to apply a two dimensional strip analysis along streamlines calculated by the three-dimensional panel code. There are differences in streamline direction between those determined from a boundary layer analysis and those from the panel code. The differences in ice shape development caused by use of the panel code results are most likely smaller than the accuracy level of the ice growth prediction method, given the geometric resolution limits established by the surface grid.

Thus, the integral boundary layer calculation is started at the stagnation line, as determined from the panel code results. Then the streamline is divided up into control volumes by using the intersection of the streamline with the fore and aft panel edges as the boundaries of the control volume and a unit length in the spanwise direction as the other dimension of the control volume. Then the β value at the midpoint of the streamline segment is used as the β for the control volume. This use of the streamline β value brings in the spanwise influence on the particle trajectory, whereas a simple cut perpendicular to the leading edge would result in a somewhat different β distribution for the ice growth calculation. A representative streamline used for an ice growth calculation on a swept wing model is shown in figure 19.

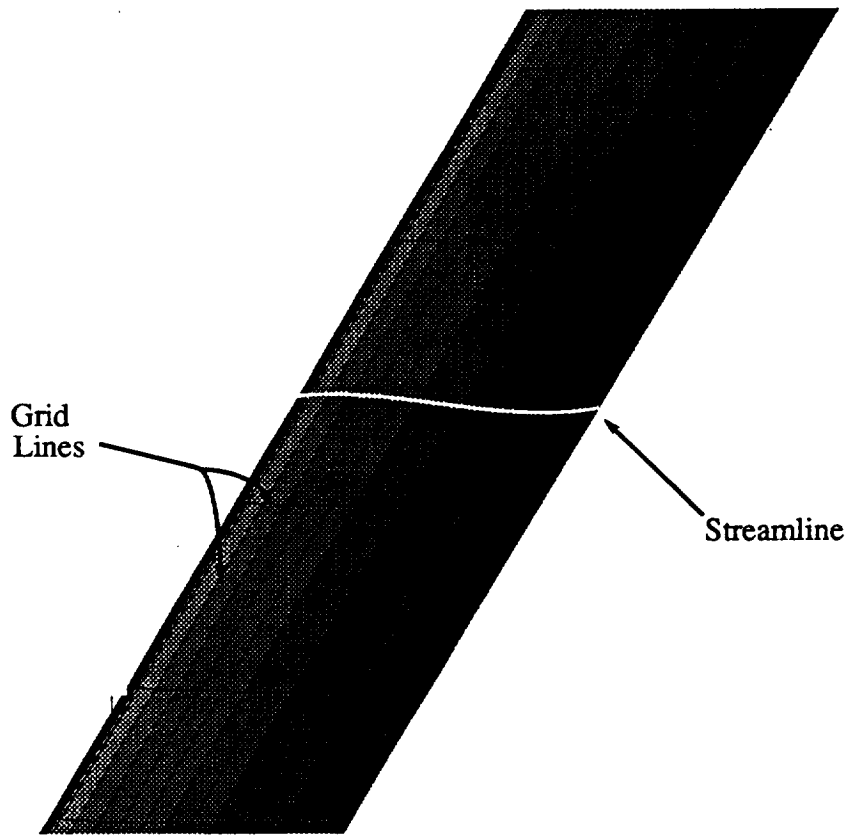

Figure 19. - Streamline on swept wing surface.

The control volumes thus correspond to a series of trapezoidal elements stacked side-by-side from the leading edge to the trailing edge on both the upper and lower surfaces. Figure 20 illustrates a series of control volumes for an arbitrary surface, including the streamline path through the center of each volume.

The β value for the element is taken as the β value at the midpoint of the streamline segment. The surface area of the bottom face of the control volume is that of a trapezoid (i.e. equal to the panel length times the panel width) and thus is equivalent to the corresponding panel area. This value is then used to determine the height of the ice accretion, using \dot{m}_i and the density of ice to determine the ice volume, resulting in the following equation for the height of ice deposited.

$$d_{ice} = \frac{\dot{m}_i \Delta t}{\rho_i A_{sur}} \quad \text{Eq. 10}$$

The thickness is then considered to be uniform over the entire panel for determination of the new geometry. The new coordinates for the panel are obtained from the relation,

$$x_i = x_i + d_{ice} \hat{x}_i \quad \text{Eq. 11}$$

where x_i is the coordinate of the center of the panel in the i -direction and \hat{x}_i is the i -component of the unit normal vector for the panel.

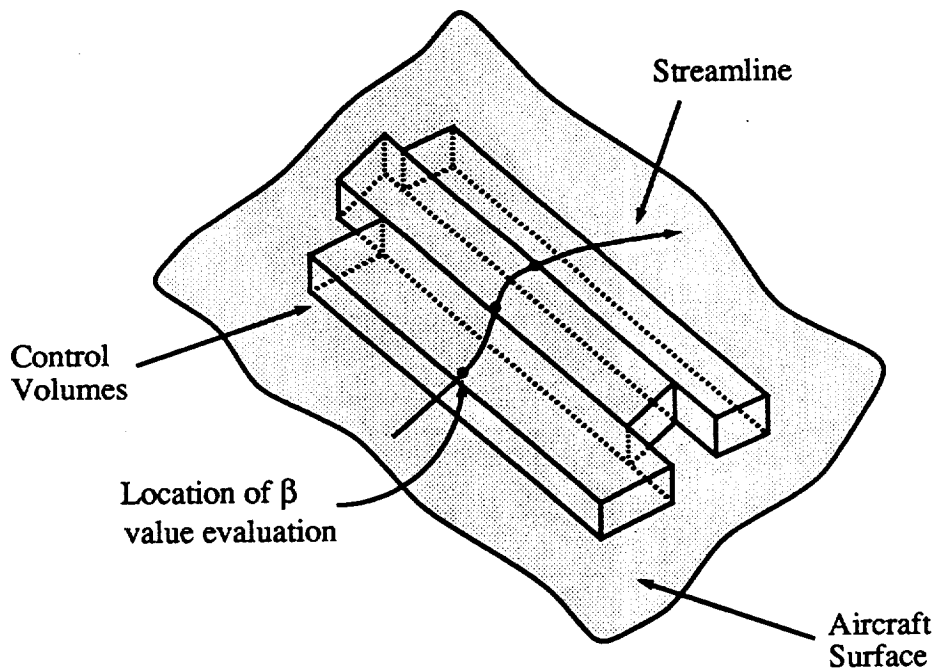

Figure 20. - Control volumes for mass and energy balance.

As the ice thickness increases, there is the possibility that the ice segments will intersect and thus this must be accounted for in the determination of the new geometry. Since this is a strip analysis, the ice thickness does not vary along the span at a given chordwise location. Therefore, the possibility of ice growth intersection is limited to the normal and chordwise directions. In that case, the line segments corresponding to the top of every other panel are examined for intersection. If the intersection is determined to occur, then a new panel is formed with its center halfway between the two old panels. This requires determination of the coordinates of the new panel and renumbering of the panels. This information is then used in subsequent potential flow calculations.

2. Printed Output

Output from LEWICE2D consists of iced streamline coordinates, surface distances, surface normals, trajectory tangents, edge velocities, collection efficiencies ice thickness, heat transfer coefficient, and static pressure and is written to units OUTPUT, JOBSUM.

J. Subroutine BODMOD

1. General Discussion

The module BODMOD generates the new geometry file (NGEOM) for the iced geometry using the ice accretion at each station of interest (generated in LEWICE2D) and the old geometry file (OGEOM). Figure 21 shows a schematic of the job stream for BODMOD. The module reads the old geometry file N-line by N-line and if no ice accretion is requested for the section (IMOD(ISEC)=0) it is written to the new geometry file (NGEOM). If an ice accretion has been calculated for the section (IMOD(ISEC)=ICEC), then the entire section is modified to reflect the ice shape calculated for the two closest streamlines and is written into the new geometry file. In essence, the old geometry file (OGEOM) is transferred to the new geometry file (NGEOM) and it is overlaid only at sections where ice shapes have been calculated.

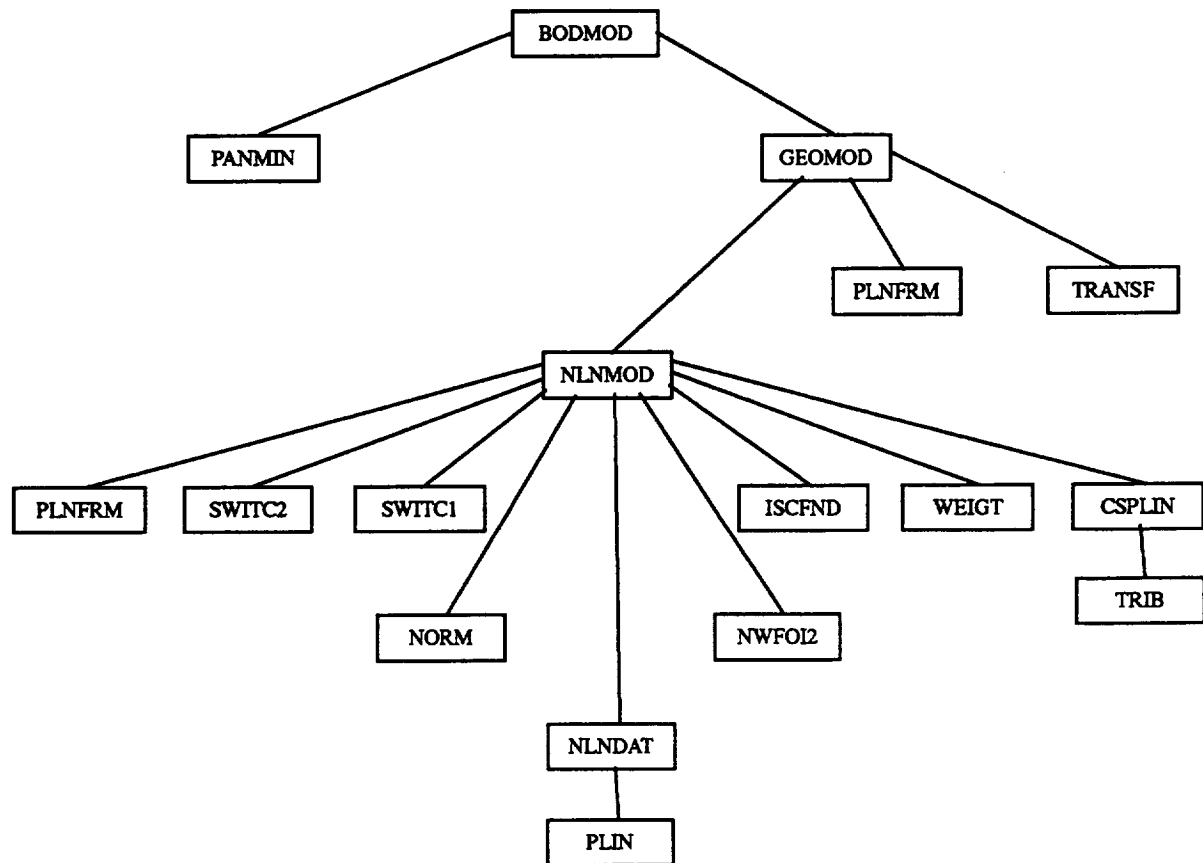

Figure 21. - BODMOD segmentation tree structure.

Subroutine BODMOD controls the modification of each N-line and is comprised of two steps. First it takes the ice thickness distribution from each of the iced streamlines and extrapolates or interpolates that distribution upon each N-line and second, it calculates the new N-line using the ice thickness distribution and either the surface normals or trajectory tangents. The algorithm uses a cubic interpolation of ice thickness as a function of surface distance in the flow direction and a linear interpolation of ice thickness as a function of spanwise position in the spanwise direction. Once the ice thickness distribution has been determined for each point on the N-line, the new N-line is generated by adding the interpolated ice thickness at each point to the old N-line in either the surface normal or the trajectory tangent direction as described in the LEWICE2D section.

The first step in generating the new N-line is to determine the closest iced streamlines to the N-line. If only one iced streamline was calculated then the N-line receives the ice thickness distribution calculated for that streamline (DICES(I,1) vs. SST(I,1), I=1 to NPTS). If multiple iced streamlines were calculated, then the two closest streamlines to the N-line will be found. This is

done by finding the two closest sections of interest to the N-line and using the iced streamlines associated with these sections. The two closest streamlines are denoted by IST1, IST2 and the ice thickness distribution and surface distance associated with each of the streamlines are stored in the arrays (DICE(I,IST1), SST(I,IST1), I = 1 to NPTS1, DICES(I,IST2), SST(I,IST2), I=1, NPTS2), where NPTS1, NPTS2 are the number of points in each of the iced streamlines, respectively. In addition to the above parameters the parametric distance of the N-line along the line connecting the two closest sections of interest is calculated (TL). This distance is used in the linear spanwise interpolation or extrapolation done later.

The second step is to normalize all of the streamline surface distance arrays to the surface distance arrays for the current N-line. This is done to avoid problems in the cubic spline interpolation which follows.

The third step involves interpolating the ice thickness distribution from each of the iced streamlines onto the N-line surface distance distribution. The interpolation is done using a cubic spline fit of the ice thickness vs. surface distance array.

The fourth step is to determine the ice distribution at the current N-line from the associated iced streamlines. If only one streamline is calculated then the N-Line will receive the ice thickness distribution from that streamline. If more than one streamline is calculated then a spanwise linear interpolation will be made from the two closest ice streamlines (ISTR1, ISTR2). This linear interpolation can be written

$$DICE(I) = (DICES(IST2,I) - DICES(IST1,I)) \cdot TL + DICES(IST1,I) \quad \text{Eq. 12}$$

where TL is the parameteric distance of the N-line along the line connecting the two closest sections of interest (ISTR1, ISTR2), and DICE is the ice thickness distribution for the current N-line.

The fifth and final step is to generate the new N-line. This is done by adding the ice to the old geometry in either the surface normal or trajectory tangent direction. This is the same procedure used to generate the iced streamlines, and is discussed in the LEWICE2D section.

2. Printed Output

Output for BODMOD is written to unit NGEOM and contains the new iced geometry in DUGLIFT format. For an explanation of the information in the NGEOM file see table I.

K. Summary Of Subroutines

The following tables describe the subroutines used to do the flow, trajectory, streamline, impingement efficiency, impingement efficiency interpolation, ice accretion, and geometry modification.

TABLE I. - FLOW FIELD CALCULATION SUBROUTINES

<u>Subroutine</u>	<u>Called by</u>	<u>Description</u>
AIJMX	SIGMAL	Computes the matrix, A_{ij} , of dot products of source induced velocities with normal vectors on the on-body elements.
BVORTX	CONTRL	Calls PKUTTA or FKUTTA to calculate vortex strength per unit path length around the k^{th} lifting strip, $B^{(k)}$, for all lifting strips.
CKARRY	CONTRL	Cross checks storage array capacities.
COLSOL	SIGMAL	Solves linear equation matrices for element source densities.
CONTRL	DUGLFT	Controls flow of the modified Hess code which processes body surface data for use by the flow and trajectory codes.
DATPRS	INPUTL	Translates, scales, and rotates about the y-axis surface description data immediately after input.
DKEKFK	PISWIS	Calculates D_k , E_k and F_k for use in calculating piecewise linear spanwise variation of $B^{(k)}$.
FAR3	FLOVEL	Vectorized subroutine which calculates the induced velocity from a lifting panel in the far field.
FARNL	FLOVEL	Vectorized subroutine which calculates the induced velocity from a non-lifting panel in the far field..
FKUTTA	BVORTX	Computes vortex strength, $B^{(k)}$, for each lifting strip by the flow tangency method.
FLOVE2	TRAJEC CONFAC ARYTRJ FLOPNT	Returns flow velocity for a given point in space.
FLOVEL	TRAJEC CONFAC ARYTRJ FLOPNT	Returns flow velocity for a given point in space (vectorized version).
HEADER	CONTRL INPUTL	Writes a printout header.

TABLE I. - Continued.

<u>Subroutine</u>	<u>Called by</u>	<u>Description</u>
	NOLIFT LIFT VIJMX PNTVIJ DKEKFK UNIFLO SIGMAL AIJMX NIKMX VELOCY PRINTL	
INPUTL	CONTRL	Inputs surface quadrilateral corner coordinates and controls computation of the geometric properties of lifting quadrilateral elements. Also prints the first major DUGLFT output.
LIFT	INPUTL	Computes geometric properties of lifting quadrilateral elements.
MIS1	PKUTTA FKUTTA	Linear equation solver. Used in calculation of vortex strengths, $B^{(k)}$, of lifting strips.
NEAR	VFMLFT	Computes source and vortex induced velocities from an element in a lifting strip using the near-field equations.
NEAR5	FLOVEL	Vectorized subroutine which calculates the induced velocity from a lifting panel in the near field.
NEARF	VFLIFT	Computes source and vortex induced velocities from an element in a lifting strip using the near-field equations.
NEARNL	FLOVEL	Vectorized subroutine which calculates the induced velocity from a non-lifting panel in the near field.
NIKMX	SIGMAL	Computes the right hand sides of the A_{ij} matrix, $N_i^{(k)}$ and $N_i^{(\infty)}$, which are the dot products of the onset flows with the unit normal vectors to the on-body elements.
NOLIFT	INPUTL	Calculates geometric quantities for quadrilateral elements in a nonlifting section.

TABLE I. - Continued.

<u>Subroutine</u>	<u>Called by</u>	<u>Description</u>
PATPRS	PINPUT	Translates, scales, and rotates about the y-axis surface description data immediately after input.
PEADER	PINPUT	Writes a printout header.
PISWIS	VMATRIX	Calculates $\vec{V}_{ik}^{(0)}$ and $\vec{V}_{ik}^{(1)}$ according to equation (11.2) of reference 2, and calls DKEDKFK and PSONST to calculate vortex induced onset flows. Used only for piecewise linear spanwise variation of vortex strength.
PKUTTA	BVORTX	Computes vortex strength, $B^{(k)}$, for each lifting strip by the pressure equality method.
PNTVIJ	VMATRIX	If so requested (for debugging purposes only), prints all source induced velocities, \vec{V}_{ij} , and all vortex induced velocities, $\vec{V}_{ij}^{(F)}$ and $\vec{V}_{ij}^{(S)}$.
PRINTL	VELOCITY	Prints the final output of the DUGLFT computations.
PSONST	PISWIS	Computes vortex induced onset flows when the piecewise-linear method of spanwise variation of vortex strength is used.
READ1	SIGMAL COLSOL PKUTTA FKUTTA SUMSIG VELOCITY	Reads in one singly subscripted array from a peripheral storage unit.
READ3	PNTVIJ STEPFN PISWIS PSONST UNIFLO AIJMX NIKMX	Reads three subscripted arrays from a peripheral storage unit.
SETFLO	FLOPNT ARYTRJ CONFAC TANTRA	Reads DUGLFT output data stored on unit 18 that is required by SR FLOVEL for velocity calculations. If flow velocities are calculated by other than the Hess method, this code must be replaced with a dummy call.

TABLE I. - Continued.

<u>Subroutine</u>	<u>Called by</u>	<u>Description</u>
SIGMAL	CONTRL	Controls calculation of the element source densities, $\sigma_j^{(k)}$ and $\sigma_j^{(\infty)}$.
STEPFN	VMATRIX	Computes vortex induced onset flows when the step function method of spanwise variation of vortex strength is used.
STOR18	CKARRY	Store control and quadrilateral geometrical property data on storage unit 18 for use by the flow and trajectory codes.
SUMSIG	CONTRL	Computes the combined element source strengths, $\sigma_{(j)}$.
UNIFLO	VMATRIX	Stores uniform onset flow velocities for use in calculating element source densities.
VELOCITY	CONTRL	Computes the final velocity at the centroid of each element. and controls the final printout of the DUGLFT calculation.
VFLIF3	FLOVEL	Vectorized subroutine which calculates the induced velocity from a wake panel.
VFLIFT	FLOVE2	Controls computation of velocities induced at a point in space by elements of unit source density and unit vortex strength in a lifting section.
VFMLFT	VIJMX	Controls computation of velocities induced at all control points by elements of unit source density and unit vortex strength in a lifting section.
VFMNLF	VIJMX	Computes velocities induced at all control points by elements of unit source density in a nonlifting section.
VFNLFT	FLOVE2	Computes velocities induced at a point in space by elements of unit source density in a nonlifting section.
VIJMX	VMATRIX	Controls computation of source induced velocities, \vec{V}_{ij} , and vortex induced velocities, $\vec{V}_{ij}^{(F)}$ and $\vec{V}_{ij}^{(S)}$, at the centroids of all elements.
VMATRIX	CONTRL	Subexecutive code for computation of induced and onset flow.

TABLE II. - STREAMLINE CALCULATION SUBROUTINES

<u>Subroutine</u>	<u>Called by</u>	<u>Description</u>
CLINE	STAGF	Produces a set of equi-spaced points between the two endpoints of a line segment.
CROSP	STAGF	Determines the cross product of two vectors.
DISLN	INSTRM	Computes the minimum distance between two lines and the points on each of the lines where this minimum occurs.
DSTPLN	INSTRM AREAP	Calculates the minimum distance between a point and a line and the point along the line where this minimum occurs.
FLOVEL	INSTRM STAGF STINT STREM2D STREM3D STRMLN	Vectorized velocity subroutine. Returns a velocity at a given point. Description of dependent subroutines given in Table I.
FLOVE2	INSTRM STAGF STINT STREM2D STREM3D STRMLN	Returns a velocity at a given point. Description of dependent subroutines given in Table I.
INSTRM	STREM3D	Projects off-body integrated streamline points to on-body streamline points.
PANMIN	STREM2D STREM3D	Determines the closest panel to a given point.
PLIN	INSTRM STREM2D AREAP	Given three points, determines the parametric equation of a line parallel to two of the points and which passes through a third point.
STAGF	STREM3D	Determines the off body stagnation point at a section of interest.
STINT	STRMLN	4th order Runge-Kutta integration scheme for calculating streamlines.

TABLE II. - Concluded.

<u>Subroutine</u>	<u>Called by</u>	<u>Description</u>
STREM2D	MAIN	Calculates a 2D streamline based on the intersection of a given plane and the geometry.
STREM3D	MAIN	Controls the calculation of the 3D integrated on-body streamlines.
STRMLN	STREM3D	Integrates a 3d streamline from a given point.
TRANSF	INSTRM STREM2D	Projects a set of points onto a given plane along a specified direction.

TABLE III. - COLLECTION EFFICIENCY CALCULATION SUBROUTINES

<u>Subroutine</u>	<u>Called by</u>	<u>Description</u>
ACORR	BETAC	Determines surface area correction due to sweep of surface for the "quasi" 2D impingement efficiency calculation.
ARYTRJ	BETAC	Calculates trajectories for a given set of release points.
AREAP	BETAC	Calculates the area of an N-sided polygon.
BETAC	LEWICE3D	Controls the calculation of surface impingement efficiency at a section of interest.
CDRR	PRFUN PARTCL	Given Reynolds number, returns Davies number for a sphere. Used for water drops for which Reynolds number is less than equal to 81.23.
CLINE	BETAC	Produces a set of equi-spaced points along a line between two given points.
CONFAC	BETAC	Determines the release point for a trajectory which passes within a specified tolerance of a target point at the section of interest.
DVDQ	TRAJEC	Integrates particle equations of motion for each time step.
FALWAT	PARTCL	Returns still-air, terminal settling speed for a water drop. Uses equation of Beard.
IMPACT	TRAJEC	Used in runs under control of CONFAC to adjust trajectory initial y, z coordinates to avoid impact on the body on the next trajectory after impaction has occurred. This is a problem-specific subroutine that must be programmed by the user.
IMPLIM	BETAC	Determines tangent trajectories at the section of interest.
MAP	CONFAC	Controls the iterative calculation of trajectories to a specified target point.
MATINV	MAP	Linear equation solver.
PARTCL	BETAC	Reads particle specification data and returns still-air, terminal particle settling speed and other particle data as required for the particular type of particle. This is a particle type-specific code.

TABLE III. - Continued.

<u>Subroutine</u>	<u>Called by</u>	<u>Description</u>
		The version provided here is for water drops.
POLYGO	CONFAC	Calculates area of plane polygon of N vertices. Provides cross-sectional areas of particle flux tubes which are used to compute concentration factors, concentration ratios and collection efficiencies.
PRFUN	TRAJEC	Given the particle Reynolds number, returns the factor which when multiplied by $\bar{V}_p - \bar{V}_a$ yields the first term on the right side of eq. (1). This is a particle type-specific function. The version provided here is for water drops.
STRPNT	TANTRA	Specifies a curve in three-dimensional space on which lie the initial points of all trajectories used in computing a tangent trajectory to the body. Also specifies coarse and fine step sizes to be used in traversing the curve in search of the tangent trajectory, and it steps along the curve to define new initial trajectory points under control of TANTRA. The version supplied here uses straight line curves.
TRAJEC	ARYTRJ IMPLIM MAP	Computes particle trajectories.
TRANSF	PRFUN MAP	Transforms coordinate system for the "flow system" to the "flux tube system", or reverse.
WCDRR	PRFUN PARTCL	Given Reynolds number, returns Davies number for a water drop. Used for cases where the Reynolds number is greater than 81.32.
BETINT	BSTREM	Determines which surface collection efficiency cell the streamline point lies in if any and the weighting factors for the interpolation.
BSTREM	LEWICE3D	Controls the interpolation of surface collection efficiency onto the streamline.
DISLN	BSTREM	Determines the minimum distance between a point and a line and the point on the line where this minimum occurs.

TABLE III. - Concluded.

<u>Subroutine</u>	<u>Called by</u>	<u>Description</u>
PLIN	BSTREM	Given three points determines the parametric equation of a line parallel to two of the points and which passes through the third point.

TABLE IV. - ICE ACCRETION CALCULATION SUBROUTINES

<u>Subroutine</u>	<u>Called by</u>	<u>Description</u>
BDYLR	ICECAL	Determines heat transfer coefficients and transition points for streamline.
COMPF	EBAL	Solves the energy equation for the freezing fraction.
COMPS	LEWICE2D SEGSEC	Calculates surface distance for streamline.
COMPT	EBAL	Solves the energy equation for the ice surface temperature given a value of freezing fraction.
CONST	LEWICE2D	Sets constants in /ICECOM/ for ice accretion calculation.
CPW	COMPF COMPT	Calculates specific heat of water for a given temperature.
DSTPLN	BDYLR COMPS ICECAL NWFOIL NWPTS	Determines the minimum distance between a point and a line and where this point on the line occurs.
EBAL	ICECAL	Controls the mass and energy balance for each of the segments on the streamline.
ICECAL	LEWICE2D	Controlling routine for ice distribution thickness and new airfoil point calculations at each step.
INTRST	SEGSEC	Determines if two line segments in a line intersect and if so, at which point this intersection occurs.
LEWICE2D	LEWICE3D	Controls the ice accretion calculation for a streamline.
NWFOIL	ICECAL	Computes the new x, y, z coordinates for the iced airfoil in the surface normal or trajectory tangent direction.
NWPTS	LEWICE2D	Tests the iced streamline point distribution for refinement. If segments have become too large during a time step, they are subdivided into two segments of equal size.

TABLE IV - Concluded.

<u>Subroutine</u>	<u>Called by</u>	<u>Description</u>
PLIN	INTRST	Given three points determines the parametric equation for a line parallel to two of the points and which passes through a third point.
PLNFRM	SEGSEC	Produces a plane given three points.
PLNNRM	NWFOIL	Calculates cross product of two vectors.
PVI	COMPT	Calculates the vapor pressure over ice for a given temperature.
PVW	COMPF COMPT	Calculates vapor pressure over water for a given temperature.
RHOICE	ICECAL	Calculates local ice density using Macklin correlation (ref. 7).
SEGSEC	ICECAL	Removes segments that intersect due to ice growth.
TRANSF	NWFOIL SEGSEC	Projects a set of points onto a given plane along a specified direction.
VEDGE	LEWICE2D	Determines edge velocity, static temperature, and pressure along a streamline.

TABLE V. - GEOMETRY MODIFICATION CALCULATION SUBROUTINES

<u>Subroutine</u>	<u>Called by</u>	<u>Description</u>
BODMOD	LEWICE3D	Controls the geometry modification at each ice step.
CSPLINE	NLNMOD	Cubic spline interpolation routine.
DSTPLN	ISCFND	Determines the minimum distance between a point and a line and where this point occurs on the line.
GEOMOD	BODMOD	Controls the modification of each N-line on a lifting section and its subsequent loading into the new geometry file.
ISCFND	NLNMOD	Finds the two closest iced streamlines to a given streamline and its relative position between them.
NLNDAT	NLNMOD	Determines the surface normals for each point on a given N-line.
NLNMOD	GEOMOD	Controls the calculation of the ice thickness distribution and geometry modification for each N-line.
NORM	NLNMOD	Normalizes an array of surface distances to a given surface distance.
NWFOI2	NLNMOD	Calculates the new points on the N-line given the old N-line points, ice thickness distribution and either the surface normals or the trajectory tangents.
PANMIN	BODMOD	Determines the number of the panel closest to a given point.
PLIN	ISCFND NLNDAT	Given three points, determines the parametric equation of a line which is parallel to two of the points and which passes through the third.
PLNFRM	GEOMOD NLNMOD	Forms a plane given three points on the plane.
SURFD	NLNMOD	Determines the surface distance distribution from a set of points.
SWITC1	NLNMOD	Transfers points from a two-dimensional array into a one-dimensional array.
SWITC2	NLNMOD	Transfers points from a three-dimensional array into a one-dimensional array.

TABLE V. - Concluded.

Subroutine	Called by	Description
TRANSF	GEOMOD NLNMOD	Projects a set of points onto a given plane along a specified direction.
TRIB	CSPLINE	Solves for coefficients in a cubic spline curve fit.
WEIGT	NLNMOD	Determines the ice distribution at an N-line from weighted values of the two closest iced streamlines.

III. INPUT FILES

Two basic input files are required to run the code and a third is optional if the restart capability of the code is used (IRES=1). A geometry file (unit OGEOM) is required for the flow field generation. The job control file (unit INPUT) is required and contains flags and inputs for the trajectory, and ice accretion calculations. The third file, which is optional, is a restart file (unit RESTRT) which allows the user to continue from the point where the last run was terminated. This file is useful for long runs where it might be more advantageous to split the job into smaller runs. A brief description of the flow field input file is contained in Hillyer Norment's trajectory code manual (ref. 5) while a more detailed description is available in the Duglift users manual (ref. 4).

The run parameter file (unit INPUT) contains basically three namelists which control the trajectory and ice accretion calculations. A description of each of the variables and namelists is given in table VI.

The DUGLIFT flow field input file (unit NGEOM) contains geometry information in DUGLIFT format. Table VII, which was taken from reference 5, gives a brief description of the input format of the variables.

In addition to the flow field and job control input files there is an optional restart file. This file allows a job to be restarted from its previous termination point. To restart a job the restart flag must be set (IRES=1) and the previous restart file must be provided on unit REST. This file contains collection efficiency and ice accretion information at each time step and section of interest. The restart file is read in subroutine REST. For information about the type and format of the data see subroutine REST.

TABLE VI. - LEWICE3D STANDARD INPUT FILE DESCRIPTION.

<u>NAMELIST</u>	<u>Variables and Format</u>	<u>Description</u>	
IMPING	IRUN, IFLOW, ICE, ISTRF, ICEC, IRES, NPSEC, NBR, NBC, XSEC, YSEC, ZSEC, XSCI, YSCI, ZSCI, XTIP, YTIP, ZTIP, DSHIFT, SHFTF, PLNST (NAMELIST FORMAT)	IRUN	Flag controlling trajectory and streamline calculations.
		=1	Only streamline calculation will be carried out. Must input XSEC, YSEC,ZSEC. (Subroutines STREM2D or STREM3D will be called depending on flag ISTRF).
		=2	CONFAC run will be carried out to determine trajectories that pass XSEC,YSEC,-ZSEC, (subroutine CONFAC).
		=3	Tangent trajectories will be determined. Must input XSCI,YSCI,ZSCI. (subroutine TANTRA).
		=4	An array of particles will be released and collection efficiencies will be calculated. Must input XTIP, YTIP, ZTIP. (subroutine ARYTRJ).
		=5	All of the above will be calculated. Must input XSEC,YSEC,ZSEC.
		=6	CONFAC run will be carried out, followed by a tangent trajectory, and a collection efficiency run.
		=7	Streamline calculation will be carried out followed by a tangent trajectory, and a collection efficiency run. Must input XSEC,YSEC, ZSEC.
		=8	Tangent trajectory calculation will be followed by a collection efficiency run. Must input XSCI, YSCI, ZSCI. Collection efficiency run will be carried out and will be followed by tangent trajectory run. Must input XSEC, YSEC, ZSEC.
		=0	Flow solver will not be run. Must provide geometry on OGEOM.
		=1	Flow solver will be run. Must provide geometry on unit OGEOM.
		ICE	Ice accretion calculation control variable.

TABLE VI. - Continued.

<u>NAMELIST</u>	<u>Variables and Format</u>	<u>Description</u>
	=0	Lewice2D ice accretion calculation will not be run.
	=1	Lewice2D ice accretion calculation will be run. Must provide accretion calculation variables. (NAMELIST ICEIN)
ISTRF		Streamline calculation control variable.
	=0	A 3D streamline will be integrated along the surface at the section of interest. Must input XSEC, YSEC, ZSEC.
	=1	A 2D cut will be generated along the surface. The 2D slice will be the intersection between the surface and the plane input by the user (PLNST(ICEC,4)) where the plane is: $\text{PLNST(ICEC,1)*X} + \text{PLNST(ICEC,2)*Y} + \text{PLNST(ICEC,3)*Z} + \text{PLNST(ICEC,4)} = 0$ <p>The user must input PLNST, and XSEC, YSEC, and ZSEC.</p>
ICEC		The number of sections for which the above trajectory or ice accretion calculations will be made.
IRES		Restart flag.
	=0	No restart will be made and job will run from the beginning.
	=1	Job will continue from last point of execution. Must link restart file (unit 26)
NPSEC		Variable controlling the type of region at the section of interest.
	=2	The region at the section of interest is a line and hence only two points are needed to describe it (i.e. XSEC(ICEC,1), YSEC(ICEC,1), ZSEC(ICEC,1) and XSEC(ICEC,2),

TABLE VI. - Continued.

NAMELIST	Variables and Format	Description
		YSEC(ICEC,2), ZSEC(ICEC,2) fully describe the region at the surface). This type of calculation is justified for regions where no spanwise variation in the flow field or collection efficiency is expected. A single row of trajectories will be released along the section line and a 2D beta calculation will be used for determining collection efficiency. Flow field data are linearly extrapolated onto the streamline assuming no spanwise variation.
=4		The region at the section of interest is a rectangle and hence four points are needed to describe the region of interest (i.e. XSEC(ICEC,1), YSEC(ICEC,1), ZSEC(ICEC,1) and XSEC(ICEC,2), YSEC(ICEC,2), ZSEC(ICEC,2), XSEC(ICEC,3), YSEC(ICEC,3), ZSEC(ICEC,3) and XSEC(ICEC,4), YSEC(ICEC,4), ZSEC(ICEC,4) describe the four corners of the rectangle at the section of interest. This type of calculation is for regions where the flow is expected to be fully 3D. A matrix of trajectories will be released into the rectangle of interest to generate a distribution of collection efficiencies on the surface. A 3D collection efficiency is made. The collection efficiency and flow field data are interpolated onto the streamline using linear interpolation.
NBR		The number of rows of trajectories to be released at each section of interest NBR(ICEC). Typical value is 20.
NBC		The number of columns of trajectories to be released at each section of interest NBC(ICEC). For the 2D Approximation (i.e. NPSEC(ICEC)=1) NBC will be set to one and only a line of NBR(ICEC) trajectories will be released at the section of interest.
XSEC,		

TABLE VI. - Continued.

<u>NAMELIST</u>	<u>Variables and Format</u>	<u>Description</u>
	YSEC, ZSEC	Arrays describing the region of interest. Depending on NPSEC(I), I=1, ICEC either a line is desired (NPSEC=2) and two points along this line must be entered, or a rectangle is desired (NPSEC=4) and the four corner points of the rectangle of interest must be entered. The points must be off-body points. These arrays are needed to run the streamline and CONFAC calculations.
	XSCI, YSCI, ZSCI	Arrays either generated by subroutine CONFAC or input by the user that define upstream release points for trajectories that pass through the points XSEC, YSEC, ZSEC at the region of interest. These arrays are needed to run the tangent trajectory routine.
	XTIP, YTIP, ZTIP	Arrays either generated by subroutine TANTRA or input by the user that define upstream release points for tangent trajectories for the upper and lower surface along the line defined by XSCI, YSCI, ZSCI at the region of interest. These arrays define the region to release impacting trajectories. These arrays are needed to run the ARYTRJ trajectory subroutine which generates collection efficiency data.
	DSHIFT	Normal distance off-body where the streamline integration is started. Because of velocity gradient problems at panel edges, integration of a streamline at the surface is difficult. For this reason the streamline integration is made at a distance off the body equal to DSHIFT. Typical values are 0.002.

TABLE VI. - Continued.

<u>NAMELIST</u>	<u>Variables and Format</u>	<u>Description</u>
		<p>SHFTF Variable which controls the amount the surface is shifted to overcome difficulties in integrating the trajectories due to high velocity gradients near panel edges. The surface is shifted in the flow direction an amount equal to SHFTF*DHSIFT. The default value for SHFTF is 0.0. Typical values may range from 0.0 to 1.0.</p>
		<p>PLNST Array defining plane which is to cut surface to generate 2D streamline at each section of interest. Plane is defined as</p> $\text{PLNST}(\text{ICEC},1)*X + \text{PLNST}(\text{ICEC},2)*Y + \text{PLNST}(\text{ICEC},3)*Z - \text{PLNST}(\text{ICEC},4) = 0$ <p>Array PLNST must be entered if ISTRF=1.</p>
		<p>IPLLOT Logical variable controlling output of trajectory information.</p>
TRAJ	<p>IPLLOT, VINP, CHORD, RHO, VIS, HI, HMINI, IDIS, TPRINT, XSTART, XFINAL EPSE, NW, RW, TOL, XE, YE, XI, YI, DMDS, PLWC, FNR, DFINE, (NAMELIST FOR- MAT)</p>	<p>=TRUE Trajectories are written to unit TEMP24. =FALSE No trajectory data is output.</p> <p>VINP Airspeed (M/S). CHORD Characteristic dimension of body (M). RHO Air density (Kg/M3). VIS Air viscosity (Kg/(M-S)). HI Initial time step for numerical integrator. Typical value is 0.1. HMINI Minimum time step for numerical integrator. Typical value is 0.00001.</p>

TABLE VI. - Continued.

<u>NAMELIST</u>	<u>Variables and Format</u>	<u>Description</u>
IDIS		The number of the particle sizes in the particle distribution. If IDIS is greater than one, a particle distribution is assumed and DMDS(I), PLWC(I), I = 1, IDIS must be input. If IDIS = 1 than PWLC(1)=1.TPRINT Output time interval for trajectory plotting arrays. Typical value is 0.1.
XSTART		Initial X release plane for trajectory calculations (non-dimensional).
XFINAL		Termination X plane for trajectory integration (non-dimensional).
EPSI		Array used to control local error in trajectory integration in each of the coordinated directions. Typical values are 0.000001.
NW		Number of trajectories used to define the flux tube periphery. This parameter should only be greater than one if off body concentration factors are desired. If NW =1, then single trajectories are computed.
RW		Radius of particle flux tube in target plane. Only used if NW is greater than one.
TOL		Tolerance for reaching a point on tangent plane. Controls how closely trajectories pass through points XSEC, YSEC, ZSEC in the CONFAC calculation.
XE, YE		Target point coordinates of the last three guesses. Used in subroutine CONFAC in search for target point trajectories (see subroutine CONFAC).
XI, YI		Initial point coordinates of the last three guesses. Used in subroutine CONFAC in search for target point trajectories (see sub-

TABLE VI. - Concluded.

NAMELIST	Variables and Format	Description
		routine CONFAC).
		DMDS Distribution of droplet or ice aggregate diameters to be run: DDS(I), I=1, IDIS.
		PLWC Distribution of percent liquid water content for the distribution of particles. If IDIS =1 then PLWC = 1.
		FNR Froude number. If gravitational forces in the z-direction are to be considered then FNR = 1. The default value for FNR is 0 or no gravitational forces.
		DFINE Step size used in search for tangent trajectory.
		LWC Liquid water content of cloud (g/m^3).
ICEIN	LWC, TAMB, PAMB, RH, XKINIT, SEGTOL, QCOND, TSTOP, DTIME, DTFLW (NAMELIST FORMAT)	TAMB Ambient temperature (K).
		PAMB Ambient pressure (Pa).
		RH Relative humidity of cloud (percent).
		XKINIT Roughness factor (m).
		SEGTOL Maximum growth length of a surface segment before it is divided into two surface elements.
		QCOND
		TSTOP Length of icing encounter (sec).
		DTIME Time stepping for ice growth (sec). Should be fraction of DTFLW.
		DTFLW Time stepping for flow field calculation (sec). Should be fraction of TSTOP.

TABLE VII. - DUGLIFT INPUT FILE DESCRIPTION

<u>Card No.</u>	<u>Variables and Format</u>	<u>Description</u>
Card No.	Variables and format	Description.
1	TITLE(I, I=1, 18), A4	Run identification.
2	CASE, LIFSEC, IATAACK, NSYM1, NSYM2, MPR, LEAK, FRAC, MACH (A4,6I4,2X,2F10.0)	Run control data: CASE Four character body identification. (col. 1-4) LIFSEC Total number of lifting sections. (col. 5-8) IATAACK Number of angles of attack (i.e., uniform (co. 9-12) free stream flows) to be specified via cards no. 4. Maximum value is 10. If the com- pression correction is to be applied (MACH > 0.0), it is necessary that IATAACK = 1. NSYM1 One of the three values 0, 1 or -1 is entered. (col.13-16) NSYM1 specifies the 1st symmetry plane, NSYM2 and NSYM2 specifies the second (col.17-20) symmetry plane according to 0 nonexistent. +1 a plus (ordinary symmetry plane. - 1 a minus (anti) symmetry plane. MPR Print flag used for program debugging only. (col. 21-24) 0 No debug print. This is the normal value for this parameter. 1 Print the source induced velocity matrix, V_{ij} , and, if LIFSEC > 0, print the dipole induced velocity matrices, $V_{ik}^{(F)}$ and $V_{ij}^{(S)}$. >2 Print the dot product matrices A_{ij} , $N_i^{(k)}$ and $N_i^{(\infty)}$, and the element

TABLE VII. - Continued.

Card No.	Variables and Format	Description
		source densities, $\sigma_i^{(k)}$ and $\sigma_i^{(\infty)}$
3		Print the onset flow matrices, $V_i^{(k)}$ and $V_i^{(\infty)}$
	LEAK (col. 25-28)	Number of inlet quadrilateral elements. These must be the first elements in the digital description set (cards no. 12).
	FRAC (col.31-40)	Fraction of unit free stream flow that passes through each of the LEAK inlet elements. If LEAK = 0, leave this field blank.
	MACH (col.41-50)	Mach number of the free stream flow. (Note that this is a floating point number.) If $N_M < 0.5$, leave this field blank.
3	IPOS, LOFF, MOMENT, LIST, IOUT (5L)	Logical control flags:
	IPOS (col. 1)	If true, the card 12, 13, and 15 coordinates are to be translated, scaled, and rotated about the y axis before processing, and card no. 5 is to be input. If false, no translation, scaling or rotation is done, and card no. 5 is not input.
	LOFF (col. 2)	if true, velocities at off-body points are to be calculated. The off-body points are specified by the user via input of the no. 15 cards. If false, off-body velocities are not calculated and there is no input of the no. 15 cards.
	MOMENT (col.3)	If true, the moment origin is specified by input of card no. 6. If false, card 6 is not input and moments are computed about point (0,0,0).
	LIST (col. 4)	If false, specifies complete execution. If true execution is terminated after the first main part of the printed output.

TABLE VII. - Continued.

Card No.	Variables and Format	Description
		<p>IOUT (col. 5) If true, the 29 geometric quantities for each nonlifting element and 45 geometric quantities for each lifting element are printed. The normal value for this parameter is false.</p>
4	(ALPHAX(I), ALPHAY(I), ALPHAZ(I), I=1, IATAACK) (3E10.0)	<p>Direction cosines of uniform onset (i.e., free stream) flow vectors. IATAACK is the number of uniform onset flows specified in card no. 2. One set of direction cosines per card. If the compression correction is applied (MACH. 0.0), only one uniform onset flow vector can be specified. If more than one vector is specified, only the first is passed along via unit 18 for use by SR SETFLO and FLOVEL. The direction cosines are with reference to the airplane coordinate system (after rotation by angle ANGLE (card 5)). These vectors are equivalent to unit free stream velocities. Ordinarily, free stream unit velocity components are (1.0,0.0,0.0).</p>
5	ANGLE, XSCALE, YSCALE, ZSCALE, XTRANS, YTRANS, ZTRANS, (7F10.0)	<p>Input only if IPROS = TRUE on card 3. Same as card no. 4 of program PBOXC.</p>
6	ORIGNX, ORIGNY, ORIGNZ (3E10.0)	<p>Coordinates of the moment origin. This card is input only if MOMENT = TRUE on card 3.</p>
7	LKUTT, LASWAK, PESWIS, IGW (5L1)	<p>Input only if LIFSEC > 0 on card 2. Logical control flags for lifting section data</p> <p>LKUTT (col. 1) If true, the flow tangency method for application of the Kutta condition is selected. This means that one point in or near the wake of each lifting strip (not counting extra strips) must be specified via input of card no. 9. If false, the pressure equality method is selected, and cards no.9, 13, and 14 are not input.</p>

TABLE VII. - Continued.

Card No.	Variables and Format	Description
		LASWAK (col. 2) If true, the trailing edge of the last wake element is automatically extended by the code to $x = \infty$. This is the semi-infinite last wake element option.
		PESWIS (col. 3) If true, the piecewise linear method for calculating spanwise variation of lift vorticity is selected, and lifting strip widths must be input via cards no. 11. If false, the step function option is selected, and cards no. 11 are not input.
		IGW (col. 4) If true, there are ignored lifting elements which must be defined via input of the no. 10 cards. If false, there are not ignored elements, and cards no. 10 are not input.
8	(NSORCE(J), NWAKE(J), NSTRIP(J), NLINE1(J), NLINEN(J), IXFLAG(J), J=1, LIF- SEC), (6I4)	This card only input if LIFSEC > 0 on card 2.
		NSORCE (col. 1-4) Number of on-body elements (including ignored) in each lifting strip of the Jth lifting section.
		NWAKE (col. 5-8) Number of wake elements in each lifting strip of the Jth lifting section, including a semi-infinite final element if this option is selected.
		NSTRIP (col. 9-12) Number of lifting strips in the Jth lifting section. Include extra strips only if they are defined via input of cards no. 12.
		NLINE1 (col. 13-16) If the piecewise linear option is selected, (PESWIS = TRUE on card 7), NLINE1(J) specifies the edge condition of the first strip on the Jth lifting section. If the step function option is specified, ignore this field.
		NLINEN (col. 17-20) Same as NLINE1(J) but for the last strip of the Jth lifting section.

TABLE VII. - Continued.

<u>Card No.</u>	<u>Variables and Format</u>	<u>Description</u>
		<p>IXFLAG IXFLAG(J) = 0 means that no extra strips (col. 21-24) are defined via input (i.e. via cards no. 12).</p> <p>IXFLAG(J) = 1 means the first strip is an extra strip. If the piecewise linear option is selected, this also requires NLINEN(J) = 4 or 5.</p> <p>IXFLAG (J) = 3 means the last strip is an extra strip. If the piecewise linear option is selected, (PESWIS = TRUE on card 7), this also requires NLINEN(J) = 4 or 5.</p> <p>IXFLAG(J) = 2 means that both the first and last strips are extra strips. If the piecewise linear option is specified, this requires that both NLINE1(J) and NLINEN(J) = 4 or 5.</p> <p>LIFSEC is specified on card 2. A separate card is required for each lifting section, and the cards are input in the same order as input of the quadrilateral data via cards no. 12.</p>
9	KUTTA(I4)	<p>Input only if LIFSEC > 0 on card 2 and if LKUTT = true on card 7. Number of points which the flow tangency method for application of the KUTTA conditions is to be applied. It is required that KUTTA equal the total number of lifting strips, not counting extra strips. KUTTA is used to read the point coordinates, and the unit vectors normal to the wake or airfoil surface at these points, via cards no. 13 and 14.</p>
10	((IG1(I,J), IGN(I,J), I=1, NSTRIP(J)), J=1, LIFSEC), (12I4)	<p>Input only if LIFSEC > 0 on card 2 and if IGW = TRUE on card 7. I = lifting strip index: J = lifting section index. If on the Ith strip of the Jth lifting section there is a substrip of ignored elements, the substrip is defined by specifying its beginning and ending element indices via</p> <p>IG1(I,J) = index of the first ignored element on the lifting strip.</p>

TABLE VII. - Continued.

Card No.	Variables and Format	Description
		IGN(I,J) = index of the last ignored element on the lifting strip.
		If there are no ignored elements on a strip, leave both fields blank: but IG1 and IGN must be specified for every lifting strip if IGW = TRUE on card 7. Six strips per card. Each lifting section begins a new card.
		LIFSEC is specified on card 2, and NSTRIP(J) on card 8.
11	(WIDXTR(I,J), (WIDTH(I,J), I=2, NSTRIP(J)-K), WIDX- TR(2,J), J=1, LIFSEC), (7E10.0)	Input only if LIFSEC > 0 and if PESWIS = TRUE on card 7. These quantities are the widths of each lifting strip for use in calculating the spanwise variation of vorticity via the piecewise linear method.
	K = 0 if IXFLAG(J) = 0	WIDXTR(1,J) specifies the width of the first extra strip of the Jth lifting section. If NLINE1(J) NE 4, leave this field blank.
	K = 1 if IXFLAG(J) = 1 or 3	WIDTH(I,J) specifies the width of the Ith lifting strip of the Jth lifting section.
	K = 2 IF IXFLAG(J) = 2	WIDXTR(2,J) specifies the width of the last extra strip of the Jth lifting section. If NLINEN(J) NE 4, leave this field blank.
		LIFSEC is specified on card 2, and NSTRIP(J), NLINE1(J), NLINEN(J) and IXFLAG(J) are specified on card 8.
12	X, Y, Z, STAT, LAB, XX,YY, ZZ, STATT, LABL, (3E10.0,2I2/ 3E10.0,2I2)	On-body wake quadrilateral element corner point coordinates are specified by these cards for both lifting and nonlifting sections, one point per card. The body and wake surface panels are constructed from these data. (Note: there must be an even number of no. 12 cards. Add a blank card to the end of the card 12 deck if necessary).
		X, Y, Z Quadrilateral corner point coordinates.

TABLE VII. - Continued.

Card No.	Variables and Format	Description
	XX, YY, ZZ (col. 1-30)	
	STAT STATT (col. 32)	Status parameter: Allowed values are 0, 1, 2,3: 0 This point is on the same N-line as the last point. 1 This point starts a new N-line. 2 This point starts a new section. 3 This is the last point in the card 12 input.
	LAB LABL (col. 32)	Specifies a lifting or nonlifting section 0 Nonlifting. 1 Lifting. This field is relevant only when STAT or STATT = 2, that is, only on the first card of a new section.
13	(XC(I), YC(I), ZC(I), I=1, KUTTA) (3E10.0)	Input only if LKUTT = TRUE on card 7. KUTTA is specified via the card 9 input. Coordinates of points (one point per card) at which the Kutta condition is to be applied via use of the flow tangency method. If IPROS = TRUE (card 3), the coordinates according to the card 5 input data.
14	(XN(I), YN(I), ZN(I), I=1, KUTTA) (3E10.0)	Input only if LKUTT = TRUE on card 7. KUTTA is specified via the card 9 input. Components of the unit vectors (one vector per card) normal to the wake or airfoil surface at the points specified by the no. 13 cards at which the Kutta condition is to be applied via use of the flow tangency method. The order of input must be consistent with that of the no. 13 cards. If IPROS = TRUE (card 3), a transformation is automatically applied by the code to adjust for rotation of coordinates by angle ANGLE (card 5).

TABLE VII. - Concluded.

<u>Card No.</u>	<u>Variables and Format</u>	<u>Description</u>	
15	XOF, YOF, ZOF, STAT, XOFF, YOFF, ZOFF, STATT, (3E10.0, I2/ 3E10.0, I2)	XOF, YOF, ZOF XOFF, YOFF, ZOFF (col. 1-30)	Coordinates of off-body points at which flow velocities are to be calculated, one point per card.
		STAT STATT (col. 32)	Status parameter. A value of 3 signifies the end of the off-body points. Otherwise, leave this field blank.

If IPROS=TRUE (card 3), the code automatically translates, scales, and rotates these coordinates according to the card 5 input data.

IV. REFERENCES

1. Hess, J.L. "Calculation of Potential Flow About Arbitrary Three-Dimensional Lifting Bodies," Report MDC J5679-01, Douglas Aircraft Co., Inc., Long Beach, CA., Oct. 1972.
2. Hess, J.L. and Smith, A.M.O. "Calculation of Non-Lifting Potential Flow About Arbitrary Three -Dimensional Bodies," Report E.S. 40622, Douglas Aircraft Co., Inc., Long Beach, CA., Mar. 15, 1962.
3. Hess, J.L. and Smith, A.M.O. "Calculation of Non-Lifting Potential Flow About Arbitrary Bodies," Progress in Aeronautical Sciences, Volume 8, D. Kuchemann, ed., Pergammon Press, New York, 1967, pp. 1-138.
4. Mack, D.P. "Calculation of Potential Flow About Arbitrary Three-Dimensional Lifting Bodies. Users Manual," Report MDS J5679-20, Douglas Aircraft Co., Inc., Long Beach, CA., Oct. 1972.
5. Norment, H.G. "Calculation of Water Drop Trajectories To and About Three-Dimensional Lifting and Non-lifting Bodies In Potential Airflow," NASA CR-3935, 1985.
6. Krogh, F.T. "Variable Order Integrators for Numerical solutions of Ordinary Differential Equations," Report NPO-11643, 1971.
7. Ruff, G.A., Berkowitz, B.M." Users manual for the NASA Lewis Ice Accretion Prediction code (LEWICE)," NASA CR-185129, 1990.
8. Kim, J.J. "Particle Trajectory Computation on a 3-Dimensional Engine Inlet," NASA CR-175023, 1986
9. Tribus, M.V. et al."Analysis of Heat Transfer Over a Small Cylinder in Icing Conditions on Mount Washington," ASME Trans., vol. 70, 1949, pp. 871-876.
- 10 Messinger, B.L."Equilibrium Temperature of an Unheated Icing Surface as a Function of Air-speed," J. Aeronaut. Sci., vol. 20, no. 1, 1953, pp. 29-42.

V. EXAMPLE CASE

For the test case, a swept NACA 0012 airfoil with a 30 degree sweep, an aspect ratio of 1.4, and a .4399 meter chord was used (fig. 22). Calculations at 0 degrees angle of attack were made for this configuration at two different airspeeds, 150 MPH and 165 MPH. This choice allowed for direct comparison to experimental impingement data for the 165 MPH case and to ice accretion data for the 150 MPH case. Because the cases were very similar, only the ice accretion related run files have been included. The experimental impingement calculations are summarized in figure 23. The various steps in producing an ice shape for a 3D geometry are illustrated.

The ice accretion calculations were carried out in a single run on the Cray XMP at LEWIS. The calculation conditions were airspeed, 150 MPH; angle-of-attack, 0 degrees; drop size, 20 microns; LWC, .75 g/m³; icing time, 2 minutes. Three sections of interest were chosen to resolve the spanwise ice shape. Because of the relative shortness of the icing encounter a single step ice accretion calculation was chosen. These sections of interest were located at the 10, 50 and 90% span locations. The panel model contained one lifting section containing 14 lifting strips of constant width and 91 chordwise segments. This model yielded 1218 lifting elements. Figures 24 and 25 show the job control input file (unit INPUT) and the flow field input file respectively (unit OGEOM). Figure 26 contains the job summary file (unit JOBSUM). The entire calculation required approximately 1340 seconds on the Cray XMP.

The first step is to generate a flow field. If the same flow field will be used for several trajectory runs then it is suggested that the flow field be generated on the first run (IFLOW=1) and saved (unit FLOWF) for any runs thereafter (IFLOW=0). It is also a good idea when calculating flow for a panel model for the first time to do a flow field calculation only (IRUN=0, IFLOW=1) and inspect the quality of the panel solution. A summary of the flow field calculation is contained on unit (FLSUM). Criteria such as smoothness of the pressure and vortex distributions are used to measure the quality of the flow field solution. Because of the relatively small execution time required for the flow field generation (90 seconds on the Cray XMP) and the ensured quality of the panel model, the flow field was generated in a single run along with the trajectory and ice accretion calculation (IRUN=5, IFLOW=1) and was stored (unit FLOWF). The job control input file (unit INPUT), the DUGLIFT geometry file (unit OGEOM), and the job summary file (unit JOBSUM) are shown in figures 24, 25, and 26 respectively. Figure 27 shows the pressure distribution at the 0% spanwise location

The second through fourth steps involve various steps in finding the ice accretion at each station of interest. These steps are repeated for each station of interest.

The second step involves calculation of the streamline at the current section of interest. This requires finding the local stagnation zone, integrating upper and lower off-body streamlines from this stagnation zone and finding the on-body projection of the off-body streamline. This calculation required about 10 seconds for each section of interest. The coordinates for the off-body and on-body streamlines along with other information are contained in the job summary output (unit JOBSUM). Figure 28 illustrates the off-body and on-body streamlines at the 0% span location.

The collection efficiency at the station of interest is determined in the third step. This

involves determining the upstream release points of the droplets that would pass through the points at the leading edge demarcating the section of interest, determining the tangent trajectories associated with these upstream release points, calculating the impact trajectories between these tangent trajectories, and calculating the collection efficiency resulting from these impact trajectories. The job summary output file shown in figure 26 summarizes the pertinent information from these runs. Approximately 448 seconds on the Cray XMP were required to complete the trajectory calculations for each section. Figure 29 depicts the impact trajectories generated in the collection efficiency calculation.

During the fourth step the surface collection efficiencies generated in step three are used to find the collection efficiencies along the streamline generated in step two. Depending upon the value of NPSEC chosen, the determination of the collection efficiency values along the streamline are calculated from either an extrapolation (NPSEC=2) or an interpolation (NPSEC=4). In the current example very little spanwise variation was expected hence a "quasi-2D" collection efficiency calculation was made (NPSEC=2). The interpolation or extrapolation proceeds quickly and only required .1 seconds on the Cray XMP. The results from this calculation are summarized in the job summary output file (unit JOBSUM) in figure 26. Steps two through four are repeated for each of the sections of interest.

Ice accretion along the streamline is calculated in step five for each of the streamlines. This involves calculating the ice thickness as a function of surface distance along the streamline at the current section of interest. The ice thickness distribution is calculated using a 3D version of the LEWICE heat transfer subroutine (ref. 7). The ice accretion at the local section is then calculated by adding the ice thickness calculated at a point to the point in either the surface normal or trajectory tangent direction. This results in a new off-body "iced-streamline" shown in figure 30. In addition to the calculation of the "iced-streamline" the ice thickness distribution for each streamline is stored for the geometry modification calculation in step six. The ice accretion calculation, which proceeds fairly quickly (.2 seconds), is summarized in the job summary output file (unit JOBSUM) in figure 26. Step 5 is repeated for each of the sections of interest.

The sixth and final step involves calculating the new geometry from the ice thickness distribution at each section of interest. This involves a cubic chordwise interpolation and a linear spanwise interpolation. The geometry modification calculations took approximately 1 second on the Cray XMP. Figure 31 shows the resulting iced wing resulting from the calculations. Figure 32 shows a comparison between the calculation and experiment for this case. In general the agreement is good with the calculation predicting the shape, amount and position of the ice.

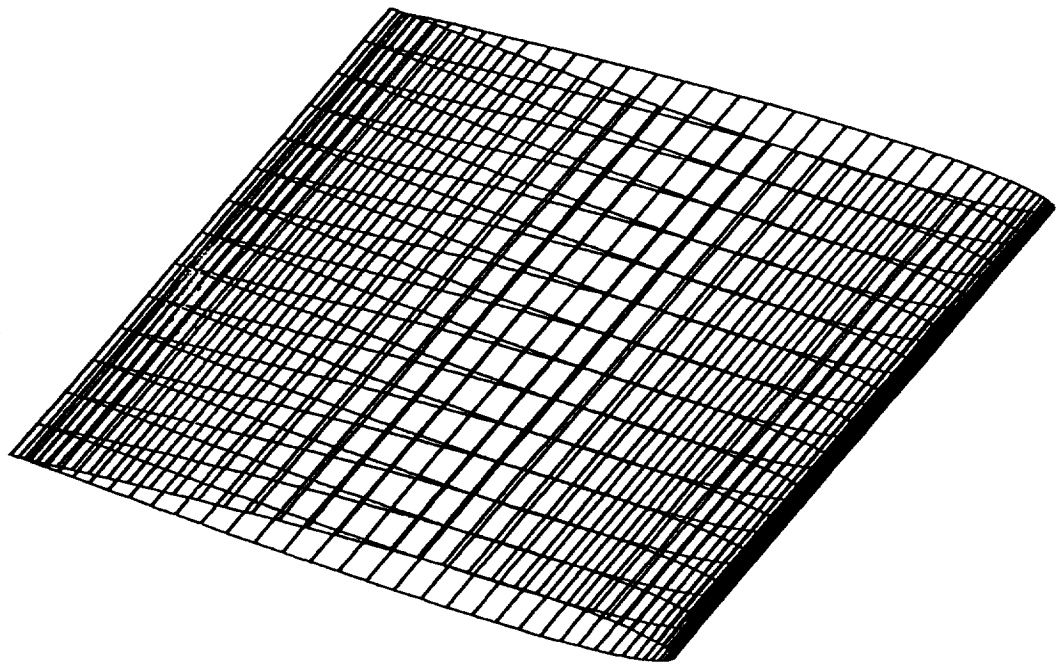

Figure 22. - Swept NACA 0012 panel model used in example case.

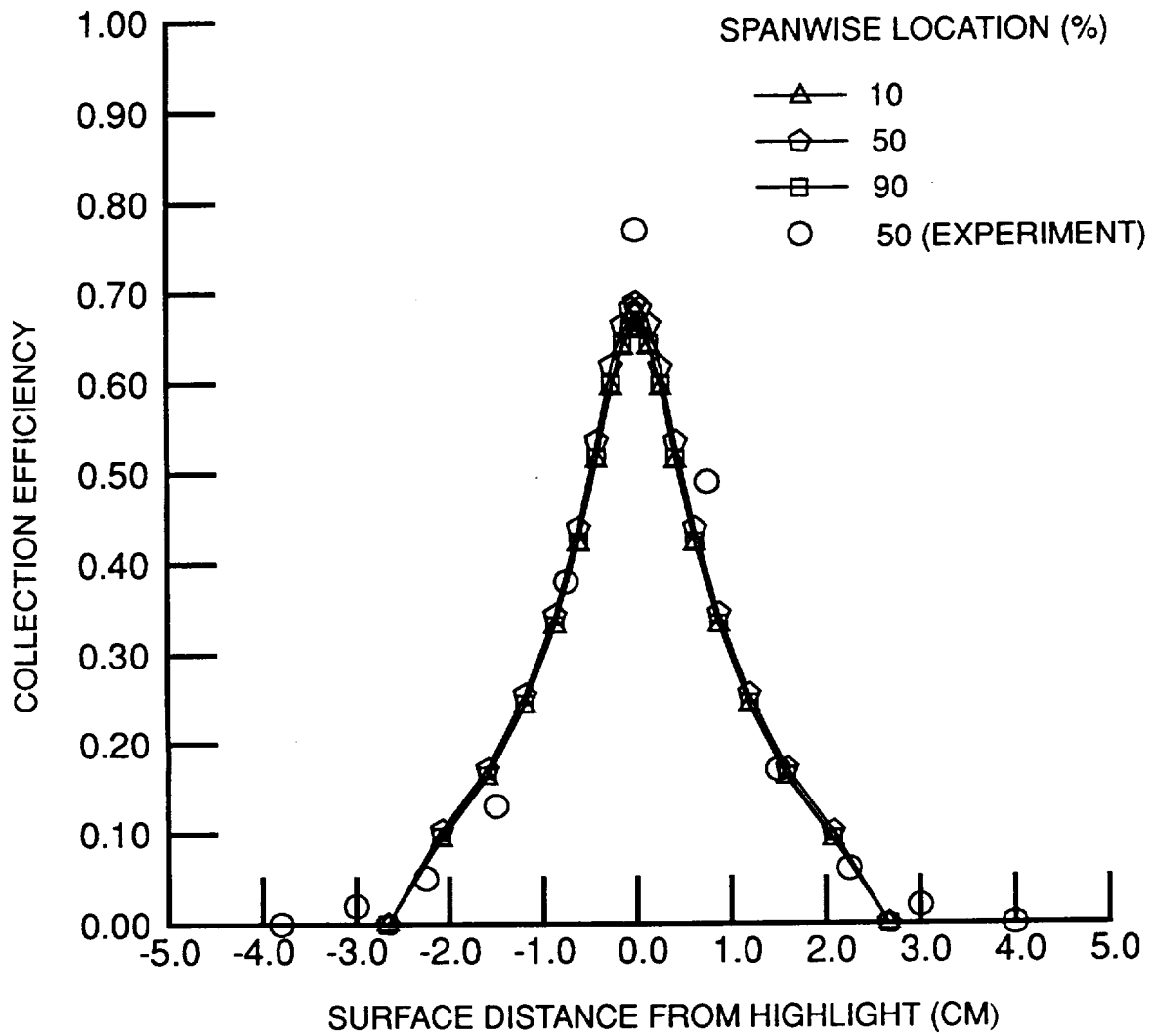

Figure 23. - Collection efficiency as a function of surface distance and spanwise location for the example case.

```

N012
SWEPT NACA0012 AIRFOIL (30 DEGREE SWEEP) EXAMPLE
&TRAJ DFINE=.0001,DMDS(1)=20.,
  VINF=67.0,CHORD=.4399,
  RHO=1.29,RW=.1,TOL=.02,FNR=0.0,
  HMINI=.0001,HI=.01,XSTART=-20.,XFINAL=1.5,TPRINT=.1,EPSI(1)=2.E-07,
  EPSI(2)=2.E-07,EPSI(3)=2.E-07 &END
&IMPING IRUN=5,ICE=1,ICEC=3,IFLOW=1,ISTRF=0,NBC(1)=1,NBR(1)=20,
NBC(2)=1,NBR(2)=20,NBC(3)=1,NBR(3)=20,NPSEC(1)=2,NPSEC(2)=2,
NPSEC(3)=2,SHFTF=0.,DSHIFT=.002,IRES=0,
XSEC(1,1)=0.,XSEC(1,2)=0.,XSEC(1,3)=0.,XSEC(1,4)=0.,
YSEC(1,1)=0.,YSEC(1,2)=0.,YSEC(1,3)=0.01,YSEC(1,4)=0.01,
ZSEC(1,1)=0.07,ZSEC(1,2)=-0.05,ZSEC(1,3)=0.07,ZSEC(1,4)=-0.05,
XSEC(2,1)=0.318,XSEC(2,2)=0.318,XSEC(2,3)=0.,XSEC(2,4)=0.,
YSEC(2,1)=0.55,YSEC(2,2)=0.55,YSEC(2,3)=0.01,YSEC(2,4)=0.01,
ZSEC(2,1)=0.05,ZSEC(2,2)=-0.06,ZSEC(2,3)=0.07,ZSEC(2,4)=-0.05,
XSEC(2,1)=-.318,XSEC(2,2)=-.318,XSEC(2,3)=0.,XSEC(2,4)=0.,
YSEC(2,1)=-.55,YSEC(2,2)=-.55,YSEC(2,3)=0.01,YSEC(2,4)=0.01,
ZSEC(2,1)=0.05,ZSEC(2,2)=-0.06,ZSEC(2,3)=0.07,ZSEC(2,4)=-0.05,
PLNST(1,1)=0.0,PLNST(1,2)=1.,PLNST(1,3)=0.,PLNST(1,4)=0.,
PLNST(2,1)=0.0,PLNST(2,2)=1.,PLNST(2,3)=0.,PLNST(2,4)=-.55,
PLNST(3,1)=0.0,PLNST(3,2)=1.,PLNST(3,3)=0.,PLNST(3,4)=.55 &END
&ICEIN LWC=.75,TAMB=267.,PAMB=89876.,RH=100.,
XKINIT=.0045,SEGTOL=1.5,TSTOP=120.,DTIME=120.,DTFLOW=120. &END

```

Figure 24. - Job control input file for example case unit (INPUT).

HACAO012 (30 DEG) 90-x #x	0	1	2	3	4
HO12	1	1	0	0	0
FFFFT					
1.0000	0.0	.000000			
FTFF					
06	3	14	0	0	2
1.404144	0.700000	0.000000	0.000000	0.000000	0.000000
1.402044	0.700000	-0.000260	0.000000	0.000000	0.000000
1.395774	0.700000	-0.001031	0.000000	0.000000	0.000000
1.385594	0.700000	-0.002295	0.000000	0.000000	0.000000
1.371004	0.700000	-0.004057	0.000000	0.000000	0.000000
1.352755	0.700000	-0.006175	0.000000	0.000000	0.000000
1.330794	0.700000	-0.008695	0.000000	0.000000	0.000000
1.305365	0.700000	-0.011535	0.000000	0.000000	0.000000
1.276894	0.700000	-0.014636	0.000000	0.000000	0.000000
1.245064	0.700000	-0.017935	0.000000	0.000000	0.000000
1.210774	0.700000	-0.021382	0.000000	0.000000	0.000000
1.174134	0.700000	-0.024907	0.000000	0.000000	0.000000
1.135505	0.700000	-0.028449	0.000000	0.000000	0.000000
1.095524	0.700000	-0.031965	0.000000	0.000000	0.000000
1.053664	0.700000	-0.035368	0.000000	0.000000	0.000000
1.011194	0.700000	-0.038625	0.000000	0.000000	0.000000
0.968195	0.700000	-0.041647	0.000000	0.000000	0.000000
0.925025	0.700000	-0.044392	0.000000	0.000000	0.000000
0.882065	0.700000	-0.046791	0.000000	0.000000	0.000000
0.839615	0.700000	-0.048792	0.000000	0.000000	0.000000
0.798065	0.700000	-0.050333	0.000000	0.000000	0.000000
0.757705	0.700000	-0.051390	0.000000	0.000000	0.000000
0.718815	0.700000	-0.051918	0.000000	0.000000	0.000000
0.681695	0.700000	-0.051901	0.000000	0.000000	0.000000
0.646525	0.700000	-0.051329	0.000000	0.000000	0.000000
0.613594	0.700000	-0.050342	0.000000	0.000000	0.000000
0.582905	0.700000	-0.048791	0.000000	0.000000	0.000000
0.554745	0.700000	-0.046791	0.000000	0.000000	0.000000
0.529145	0.700000	-0.044392	0.000000	0.000000	0.000000
0.502895	0.700000	-0.041647	0.000000	0.000000	0.000000
0.478085	0.700000	-0.038625	0.000000	0.000000	0.000000
0.452905	0.700000	-0.035368	0.000000	0.000000	0.000000
0.429175	0.700000	-0.031965	0.000000	0.000000	0.000000
0.404145	0.700000	-0.028449	0.000000	0.000000	0.000000
0.379574	0.700000	-0.024907	0.000000	0.000000	0.000000
0.355294	0.700000	-0.021382	0.000000	0.000000	0.000000
0.332064	0.700000	-0.017935	0.000000	0.000000	0.000000
0.309814	0.700000	-0.014636	0.000000	0.000000	0.000000
0.288564	0.700000	-0.011535	0.000000	0.000000	0.000000
0.268314	0.700000	-0.008695	0.000000	0.000000	0.000000
0.249064	0.700000	-0.006175	0.000000	0.000000	0.000000
0.230814	0.700000	-0.004057	0.000000	0.000000	0.000000
0.213564	0.700000	-0.002295	0.000000	0.000000	0.000000
0.197314	0.700000	-0.000260	0.000000	0.000000	0.000000
0.182064	0.700000	0.000000	0.000000	0.000000	0.000000
0.167814	0.700000	0.000000	0.000000	0.000000	0.000000
0.153564	0.700000	0.000000	0.000000	0.000000	0.000000
0.139314	0.700000	0.000000	0.000000	0.000000	0.000000
0.125064	0.700000	0.000000	0.000000	0.000000	0.000000
0.110814	0.700000	0.000000	0.000000	0.000000	0.000000
0.096564	0.700000	0.000000	0.000000	0.000000	0.000000
0.082314	0.700000	0.000000	0.000000	0.000000	0.000000
0.068064	0.700000	0.000000	0.000000	0.000000	0.000000
0.053814	0.700000	0.000000	0.000000	0.000000	0.000000
0.039564	0.700000	0.000000	0.000000	0.000000	0.000000
0.025314	0.700000	0.000000	0.000000	0.000000	0.000000
0.011064	0.700000	0.000000	0.000000	0.000000	0.000000
0.000000	0.700000	0.000000	0.000000	0.000000	0.000000
0.921485	0.700000	0.019200	0.000000	0.000000	0.000000
0.429755	0.700000	0.022984	0.000000	0.000000	0.000000
0.440175	0.700000	0.030571	0.000000	0.000000	0.000000
0.452905	0.700000	0.034243	0.000000	0.000000	0.000000
0.468085	0.700000	0.037733	0.000000	0.000000	0.000000
0.485825	0.700000	0.040972	0.000000	0.000000	0.000000
0.506165	0.700000	0.043908	0.000000	0.000000	0.000000
0.529145	0.700000	0.046462	0.000000	0.000000	0.000000
0.554745	0.700000	0.048575	0.000000	0.000000	0.000000
0.582895	0.700000	0.050212	0.000000	0.000000	0.000000
0.613594	0.700000	0.051329	0.000000	0.000000	0.000000
0.646515	0.700000	0.051901	0.000000	0.000000	0.000000
0.681675	0.700000	0.051918	0.000000	0.000000	0.000000
0.718805	0.700000	0.051390	0.000000	0.000000	0.000000
0.757685	0.700000	0.050342	0.000000	0.000000	0.000000
0.798065	0.700000	0.048792	0.000000	0.000000	0.000000
0.839605	0.700000	0.046791	0.000000	0.000000	0.000000
0.882035	0.700000	0.044392	0.000000	0.000000	0.000000
0.925015	0.700000	0.041647	0.000000	0.000000	0.000000
0.968185	0.700000	0.038625	0.000000	0.000000	0.000000
1.011185	0.700000	0.035368	0.000000	0.000000	0.000000
1.053655	0.700000	0.031965	0.000000	0.000000	0.000000
1.095214	0.700000	0.028449	0.000000	0.000000	0.000000
1.135494	0.700000	0.024907	0.000000	0.000000	0.000000
1.174125	0.700000	0.021382	0.000000	0.000000	0.000000
1.210764	0.700000	0.017935	0.000000	0.000000	0.000000
1.245054	0.700000	0.014636	0.000000	0.000000	0.000000
1.276684	0.700000	0.011535	0.000000	0.000000	0.000000
1.305354	0.700000	0.008695	0.000000	0.000000	0.000000
1.330794	0.700000	0.006175	0.000000	0.000000	0.000000
1.352764	0.700000	0.004027	0.000000	0.000000	0.000000
1.371004	0.700000	0.002295	0.000000	0.000000	0.000000
1.385394	0.700000	0.001031	0.000000	0.000000	0.000000
1.395774	0.700000	0.000000	0.000000	0.000000	0.000000
1.402064	0.700000	0.000260	0.000000	0.000000	0.000000
1.404164	0.700000	0.000000	0.000000	0.000000	0.000000
1.412145	0.700000	0.000000	0.000000	0.000000	0.000000
1.424145	0.700000	0.000000	0.000000	0.000000	0.000000
1.429145	0.700000	0.000000	0.000000	0.000000	0.000000
1.445414	0.700000	0.000000	0.000000	0.000000	0.000000
1.466409	0.600000	0.000000	0.000000	0.000000	0.000000
1.494309	0.600000	-0.000260	0.000000	0.000000	0.000000
1.530039	0.600000	-0.001031	0.000000	0.000000	0.000000
1.527660	0.600000	-0.002295	0.000000	0.000000	0.000000
1.513270	0.600000	-0.004027	0.000000	0.000000	0.000000
1.295019	0.600000	-0.006175	0.000000	0.000000	0.000000
1.273059	0.600000	-0.008695	0.000000	0.000000	0.000000
1.247629	0.600000	-0.011535	0.000000	0.000000	0.000000
1.218959	0.600000	-0.014636	0.000000	0.000000	0.000000
1.187329	0.600000	-0.017935	0.000000	0.000000	0.000000
1.153039	0.600000	-0.021382	0.000000	0.000000	0.000000
1.116400	0.600000	-0.024907	0.000000	0.000000	0.000000
1.077769	0.600000	-0.028449	0.000000	0.000000	0.000000
1.037489	0.600000	-0.031965	0.000000	0.000000	0.000000
0.995930	0.600000	-0.035368	0.000000	0.000000	0.000000
0.953460	0.600000	-0.038625	0.000000	0.000000	0.000000
0.910460	0.600000	0.000000	0.000000	0.000000	0.000000
0.867290	0.600000	0.000000	0.000000	0.000000	0.000000
0.824310	0.600000	0.000000	0.000000	0.000000	0.000000
0.781880	0.600000	0.000000	0.000000	0.000000	0.000000
0.740330	0.600000	0.000000	0.000000	0.000000	0.000000
0.699970	0.600000	0.000000	0.000000	0.000000	0.000000
0.661080	0.600000	0.000000	0.000000	0.000000	0.000000
0.623950	0.600000	0.000000	0.000000	0.000000	0.000000
0.588790	0.600000	0.000000	0.000000	0.000000	0.000000
0.555810	0.600000	0.000000	0.000000	0.000000	0.000000
0.525170	0.600000	0.000000	0.000000	0.000000	0.000000
0.497010	0.600000	0.000000	0.000000	0.000000	0.000000
0.471410	0.600000	0.000000	0.000000	0.000000	0.000000
0.448440	0.600000	0.000000	0.000000	0.000000	0.000000
0.428090	0.600000	0.000000	0.000000	0.000000	0.000000
0.410360	0.600000	0.000000	0.000000	0.000000	0.000000
0.395180	0.600000	0.000000	0.000000	0.000000	0.000000
0.382440	0.600000	0.000000	0.000000	0.000000	0.000000
0.372020	0.600000	0.000000	0.000000	0.000000	0.000000
0.363750	0.600000	0.000000	0.000000	0.000000	0.000000
0.357430	0.600000	0.000000	0.000000	0.000000	0.000000
0.352860	0.600000	0.000000	0.000000	0.000000	0.000000
0.349120	0.600000	0.000000	0.000000	0.000000	0.000000
0.347810	0.600000	0.000000	0.000000	0.000000	0.000000
0.346830	0.600000	0.000000	0.000000	0.000000	0.000000
0.346460	0.600000	0.000000	0.000000	0.000000	0.000000
0.346640	0.600000	0.000000	0.000000	0.000000	0.000000
0.346460	0.600000	0.000000	0.000000	0.000000	0.000000
0.346830	0.600000	0.000000	0.000000	0.000000	0.000000
0.347810	0.600000	0.000000	0.000000	0.000000	0.000000
0.349120	0.600000	0.000000	0.000000	0.000000	0.000000
0.352860	0.600000	0.000000			

1.037479	0.600000	0.031965	0	0.291985	0.500000	-0.008695	0	1.179549	0.400000	-0.006175	0
1.077760	0.600000	0.020458	0	0.290075	0.500000	-0.005716	0	1.157589	0.400000	-0.008695	0
1.116380	0.600000	0.024907	0	0.289095	0.500000	-0.003135	0	1.132159	0.400000	-0.011535	0
1.153029	0.600000	0.017935	0	0.288725	0.500000	-0.001117	0	1.103489	0.400000	-0.014636	0
1.187320	0.600000	0.014636	0	0.288675	0.500000	0.000000	0	1.071859	0.400000	-0.017935	0
1.218949	0.600000	0.011535	0	0.288725	0.500000	0.001117	0	1.037569	0.400000	-0.021302	0
1.247620	0.600000	0.008695	0	0.289095	0.500000	0.003135	0	1.009730	0.400000	-0.024907	0
1.273059	0.600000	0.006175	0	0.290075	0.500000	0.005716	0	0.962300	0.400000	-0.028449	0
1.295010	0.600000	0.004027	0	0.291985	0.500000	0.008695	0	0.922020	0.400000	-0.031965	0
1.313270	0.600000	0.002295	0	0.295105	0.500000	0.011906	0	0.889460	0.400000	-0.035368	0
1.338039	0.600000	0.001031	0	0.306015	0.500000	0.015519	0	0.837990	0.400000	-0.038625	0
1.344309	0.600000	0.000260	0	0.314285	0.500000	0.019200	0	0.794990	0.400000	-0.041647	0
1.346409	0.600000	0.000000	0	0.324705	0.500000	0.022984	0	0.751820	0.400000	-0.044392	0
1.354409	0.600000	0.000000	0	0.337435	0.500000	0.026795	0	0.708840	0.400000	-0.046791	0
1.366409	0.600000	0.000000	0	0.352615	0.500000	0.030571	0	0.666410	0.400000	-0.048792	0
1.386409	0.600000	0.000000	0	0.370355	0.500000	0.034243	0	0.624860	0.400000	-0.050333	0
1.288674	0.500000	0.000000	1	0.390695	0.500000	0.037733	0	0.584500	0.400000	-0.051390	0
1.286574	0.500000	0.00260	0	0.413675	0.500000	0.040972	0	0.545610	0.400000	-0.051918	0
1.280304	0.500000	-0.001031	0	0.439245	0.500000	0.043908	0	0.508480	0.400000	-0.051901	0
1.269924	0.500000	-0.002295	0	0.467425	0.500000	0.046462	0	0.473320	0.400000	-0.051329	0
1.255534	0.500000	-0.004027	0	0.498065	0.500000	0.048575	0	0.440360	0.400000	-0.050212	0
1.237285	0.500000	-0.006175	0	0.531045	0.500000	0.050212	0	0.409700	0.400000	-0.048575	0
1.215324	0.500000	-0.008695	0	0.566205	0.500000	0.051329	0	0.381540	0.400000	-0.046462	0
1.189895	0.500000	-0.011535	0	0.603335	0.500000	0.051901	0	0.355940	0.400000	-0.043908	0
1.161224	0.500000	-0.014636	0	0.642215	0.500000	0.051918	0	0.332970	0.400000	-0.040980	0
1.129594	0.500000	-0.017935	0	0.682585	0.500000	0.051390	0	0.312620	0.400000	-0.040980	0
1.095304	0.500000	-0.021302	0	0.724135	0.500000	0.050342	0	0.294890	0.400000	-0.037433	0
1.058664	0.500000	-0.024907	0	0.766565	0.500000	0.048792	0	0.279710	0.400000	-0.030571	0
1.020035	0.500000	-0.028449	0	0.809545	0.500000	0.046791	0	0.266970	0.400000	-0.026803	0
0.979755	0.500000	-0.031965	0	0.852715	0.500000	0.044392	0	0.256550	0.400000	-0.022984	0
0.938195	0.500000	-0.035368	0	0.895715	0.500000	0.041647	0	0.248280	0.400000	-0.019200	0
0.895725	0.500000	-0.038625	0	0.938105	0.500000	0.038625	0	0.241960	0.400000	-0.015519	0
0.852725	0.500000	-0.041647	0	0.979745	0.500000	0.035368	0	0.237370	0.400000	-0.011986	0
0.809555	0.500000	-0.044392	0	1.020024	0.500000	0.031965	0	0.234250	0.400000	-0.008695	0
0.766575	0.500000	-0.046791	0	1.058655	0.500000	0.028449	0	0.232340	0.400000	-0.005716	0
0.724145	0.500000	-0.048792	0	1.095294	0.500000	0.024907	0	0.231360	0.400000	-0.003135	0
0.682595	0.500000	-0.050333	0	1.129584	0.500000	0.021302	0	0.230990	0.400000	0.000000	0
0.642235	0.500000	-0.051390	0	1.161214	0.500000	0.017935	0	0.230990	0.400000	0.000000	0
0.603345	0.500000	-0.051918	0	1.189884	0.500000	0.014636	0	0.231360	0.400000	0.001117	0
0.566215	0.500000	-0.051901	0	1.215324	0.500000	0.011535	0	0.232340	0.400000	0.003135	0
0.534055	0.500000	-0.051329	0	1.237274	0.500000	0.008695	0	0.234250	0.400000	0.005716	0
0.498075	0.500000	-0.050212	0	1.255534	0.500000	0.006175	0	0.237370	0.400000	0.008695	0
0.467435	0.500000	-0.048575	0	1.269924	0.500000	0.004027	0	0.241960	0.400000	0.011986	0
0.439275	0.500000	-0.046462	0	1.280304	0.500000	0.002295	0	0.248280	0.400000	0.015519	0
0.413675	0.500000	-0.043908	0	1.286574	0.500000	0.001031	0	0.256550	0.400000	0.019200	0
0.390705	0.500000	-0.040980	0	1.288674	0.500000	0.000260	0	0.266970	0.400000	0.022984	0
0.370355	0.500000	-0.037733	0	1.295105	0.500000	0.000000	0	0.279710	0.400000	0.026803	0
0.352625	0.500000	-0.034243	0	1.306015	0.500000	0.000000	0	0.294890	0.400000	0.030571	0
0.337445	0.500000	-0.030571	0	1.314285	0.500000	0.000000	0	0.299695	0.400000	0.035940	0
0.324705	0.500000	-0.026795	0	1.324705	0.500000	0.000000	0	0.312620	0.400000	0.040972	0
0.312620	0.500000	-0.022984	0	1.337435	0.500000	0.000000	0	0.324705	0.400000	0.043908	0
0.306015	0.500000	-0.019200	0	1.346409	0.500000	0.000000	0	0.332970	0.400000	0.046462	0
0.299695	0.500000	-0.015519	0	1.354409	0.500000	0.000000	0	0.342235	0.400000	0.048575	0
0.294890	0.400000	-0.011986	0	1.366409	0.600000	0.000000	0	0.352615	0.400000	0.050333	0
0.289695	0.400000	-0.008695	0	1.386409	0.600000	0.000000	0	0.370355	0.400000	0.051390	0
0.288675	0.400000	-0.005716	0	1.288674	0.500000	0.000000	1	0.390695	0.400000	0.051918	0
0.288725	0.400000	0.000000	0	1.286574	0.500000	0.00260	0	0.413675	0.400000	0.051901	0
0.289095	0.400000	0.001117	0	1.280304	0.500000	-0.001031	0	0.439245	0.400000	0.051329	0
0.290075	0.400000	0.003135	0	1.269924	0.500000	-0.002295	0	0.467425	0.400000	0.050212	0
0.291985	0.400000	0.005716	0	1.255534	0.500000	-0.004027	0	0.498065	0.400000	0.048575	0
0.295105	0.400000	0.008695	0	1.237285	0.500000	-0.006175	0	0.531045	0.400000	0.046462	0
0.306015	0.400000	0.011906	0	1.215324	0.500000	-0.008695	0	0.566205	0.400000	0.043908	0
0.314285	0.400000	0.015519	0	1.189895	0.500000	-0.011535	0	0.603335	0.400000	0.040980	0
0.324705	0.400000	0.019200	0	1.161224	0.500000	-0.014636	0	0.642215	0.400000	0.040980	0
0.337435	0.400000	0.022984	0	1.129594	0.500000	-0.017935	0	0.682585	0.400000	0.037433	0
0.352615	0.400000	0.026795	0	1.095304	0.500000	-0.021302	0	0.724135	0.400000	0.034243	0
0.370355	0.400000	0.030571	0	1.058664	0.500000	-0.024907	0	0.766565	0.400000	0.030571	0
0.390695	0.400000	0.034243	0	1.020035	0.500000	-0.028449	0	0.809545	0.400000	0.026803	0
0.413675	0.400000	0.037733	0	0.979755	0.500000	-0.031965	0	0.852715	0.400000	0.022984	0
0.439245	0.400000	0.040972	0	0.938195	0.500000	-0.035368	0	0.895715	0.400000	0.019200	0
0.467425	0.400000	0.043908	0	0.895725	0.500000	-0.038625	0	0.938105	0.400000	0.015519	0
0.498065	0.400000	0.046462	0	0.852725	0.500000	-0.041647	0	0.979745	0.400000	0.011986	0
0.531045	0.400000	0.048575	0	0.809555	0.500000	-0.044392	0	1.020024	0.400000	0.008695	0
0.566205	0.400000	0.050212	0	0.766575	0.500000	-0.046791	0	1.058655	0.400000	0.005716	0
0.603335	0.400000	0.051329	0	0.724145	0.500000	-0.048792	0	1.095294	0.400000	0.003135	0
0.642215	0.400000	0.051390	0	0.682595	0.500000	-0.050333	0	1.129584	0.400000	0.000000	0
0.682585	0.400000	0.051918	0	0.642235	0.500000	-0.051390	0	1.161214	0.400000	0.000000	0
0.724135	0.400000	0.051901	0	0.603345	0.500000	-0.051918	0	1.189884	0.400000	0.001117	0
0.766565	0.400000	0.050212	0	0.566215	0.500000	-0.051901	0	1.215324	0.400000	0.003135	0
0.809545	0.400000	0.048575	0	0.534055	0.500000	-0.051329	0	1.237274	0.400000	0.005716	0
0.852715	0.400000	0.046462	0	0.498075	0.500000	-0.050212	0	1.255534	0.400000	0.008695	0
0.895715	0.400000	0.044392	0	0.467435	0.500000	-0.048575	0	1.269924	0.400000	0.011986	0
0.938105	0.400000	0.041647	0	0.439275	0.500000	-0.046462	0	1.280304	0.400000	0.015519	0
0.979745	0.400000	0.038625	0	0.413675	0.500000	-0.043908	0	1.286574	0.400000	0.019200	0
1.020024	0.400000	0.035368	0	0.390705	0.500000	-0.040980	0	1.288674	0.400000	0.022984	0
1.058655	0.400000	0.031965	0	0.370355	0.500000	-0.037733	0	1.295105	0.400000	0.026803	0
1.095294	0.400000	0.028449	0	0.352625	0.500000	-0.034243	0	1.306015	0.400000	0.030571	0
1.129584	0.400000	0.024907	0	0.337445	0.500000	-0.030571	0	1.314285	0.400000	0.035940	0
1.161214	0.400000</										

0.132810	0.200000	0.019200	0.621785	0.100000	-0.041647	0.748805	0.100000	0.031965	0
0.141080	0.200000	0.022984	0.578615	0.100000	-0.044392	0.789085	0.100000	0.020458	0
0.151500	0.200000	0.026795	0.535635	0.100000	-0.046791	0.827715	0.100000	0.024907	0
0.164230	0.200000	0.030571	0.493205	0.100000	-0.048792	0.864355	0.100000	0.021302	0
0.179410	0.200000	0.034243	0.451655	0.100000	-0.050333	0.898645	0.100000	0.017935	0
0.197150	0.200000	0.037733	0.411295	0.100000	-0.051390	0.930275	0.100000	0.014636	0
0.217490	0.200000	0.040972	0.372605	0.100000	-0.051901	0.958945	0.100000	0.011535	0
0.240470	0.200000	0.043908	0.335275	0.100000	-0.051901	0.984385	0.100000	0.008695	0
0.266060	0.200000	0.046462	0.300115	0.100000	-0.051329	1.006334	0.100000	0.006175	0
0.294220	0.200000	0.048575	0.267135	0.100000	-0.050212	1.024594	0.100000	0.004027	0
0.324060	0.200000	0.050212	0.236495	0.100000	-0.048575	1.038994	0.100000	0.002295	0
0.357840	0.200000	0.051329	0.208335	0.100000	-0.046462	1.049364	0.100000	0.001031	0
0.393000	0.200000	0.051901	0.182735	0.100000	-0.043908	1.055634	0.100000	0.000260	0
0.430130	0.200000	0.051901	0.159765	0.100000	-0.040980	1.057734	0.100000	0.000000	0
0.469010	0.200000	0.051390	0.139415	0.100000	-0.037733	1.065735	0.100000	0.000000	0
0.509300	0.200000	0.050342	0.121685	0.100000	-0.034243	1.077735	0.100000	0.000000	0
0.550930	0.200000	0.048792	0.106505	0.100000	-0.030571	1.107735	0.100000	0.000000	0
0.593360	0.200000	0.046791	0.093765	0.100000	-0.026803	1.000000	0.000000	0.000000	1
0.636340	0.200000	0.044392	0.083345	0.100000	-0.022984	0.997900	0.000000	-0.000260	0
0.679510	0.200000	0.041647	0.075075	0.100000	-0.019200	0.991630	0.000000	-0.001031	0
0.722510	0.200000	0.038625	0.068755	0.100000	-0.015519	0.981250	0.000000	-0.002295	0
0.764980	0.200000	0.035368	0.064165	0.100000	-0.011986	0.966860	0.000000	-0.004027	0
0.806540	0.200000	0.031965	0.061045	0.100000	-0.008695	0.948610	0.000000	-0.006175	0
0.846020	0.200000	0.028458	0.059135	0.100000	-0.005716	0.926650	0.000000	-0.008695	0
0.885450	0.200000	0.024907	0.058155	0.100000	-0.003135	0.901220	0.000000	-0.011535	0
0.922090	0.200000	0.021382	0.057765	0.100000	-0.001117	0.872550	0.000000	-0.014636	0
0.956380	0.200000	0.017935	0.057735	0.100000	0.000000	0.840920	0.000000	-0.017935	0
0.988010	0.200000	0.014636	0.057785	0.100000	0.001117	0.806630	0.000000	-0.021382	0
1.042119	0.200000	0.011535	0.058155	0.100000	0.003135	0.769990	0.000000	-0.024907	0
1.064070	0.200000	0.008695	0.059135	0.100000	0.005716	0.731360	0.000000	-0.028458	0
1.082330	0.200000	0.006175	0.061045	0.100000	0.008695	0.691080	0.000000	-0.031965	0
1.096720	0.200000	0.004027	0.064165	0.100000	0.011986	0.649520	0.000000	-0.035368	0
1.107100	0.200000	0.002295	0.068755	0.100000	0.015519	0.607050	0.000000	-0.038625	0
1.113369	0.200000	0.001031	0.075075	0.100000	0.019200	0.564050	0.000000	-0.041647	0
1.115469	0.200000	0.000260	0.083345	0.100000	0.022984	0.520880	0.000000	-0.044392	0
1.123469	0.200000	0.000000	0.093765	0.100000	0.026795	0.477900	0.000000	-0.046791	0
1.135469	0.200000	0.000000	0.106495	0.100000	0.030571	0.435470	0.000000	-0.048792	0
1.165469	0.200000	0.000000	0.121675	0.100000	0.034243	0.393920	0.000000	-0.050333	0
1.057734	0.100000	0.000000	0.139415	0.100000	0.037733	0.353560	0.000000	-0.051390	0
1.055634	0.100000	0.000000	0.159755	0.100000	0.040972	0.314670	0.000000	-0.051901	0
1.049364	0.100000	-0.000260	0.182735	0.100000	0.043908	0.277540	0.000000	-0.051901	0
1.038984	0.100000	-0.001031	0.208335	0.100000	0.046462	0.242380	0.000000	-0.051329	0
1.024594	0.100000	-0.002295	0.236495	0.100000	0.048575	0.209400	0.000000	-0.050212	0
1.006334	0.100000	-0.004027	0.267125	0.100000	0.050212	0.178760	0.000000	-0.048575	0
0.984385	0.100000	-0.006175	0.300105	0.100000	0.051901	0.150600	0.000000	-0.046462	0
0.958995	0.100000	-0.008695	0.335265	0.100000	0.051901	0.125000	0.000000	-0.043908	0
0.930205	0.100000	-0.011535	0.372395	0.100000	0.051901	0.102030	0.000000	-0.040980	0
0.898655	0.100000	-0.014636	0.411275	0.100000	0.051390	0.081680	0.000000	-0.037733	0
0.864365	0.100000	-0.017935	0.451645	0.100000	0.050342	0.063950	0.000000	-0.034243	0
0.827725	0.100000	-0.021382	0.493195	0.100000	0.048792	0.048770	0.000000	-0.030571	0
0.789095	0.100000	-0.024907	0.535625	0.100000	0.046791	0.036030	0.000000	-0.026803	0
0.748015	0.100000	-0.028458	0.578605	0.100000	0.044392	0.025610	0.000000	-0.022984	0
0.707255	0.100000	-0.031965	0.621775	0.100000	0.041647	0.017360	0.000000	-0.019200	0
0.664785	0.100000	-0.035368	0.664775	0.100000	0.038625	0.011020	0.000000	-0.015519	0
	0.100000	-0.038625	0.707245	0.100000	0.035368	0.006430	0.000000	-0.011986	0

Figure 25. - Continued.

0.035130	-0.200000	-0.046462	0	0.076160	-0.200000	0.001031	0	-0.155865	-0.300000	0.019200	0
0.009530	-0.200000	-0.043906	0	0.882430	-0.200000	0.000260	0	-0.147595	-0.300000	0.022984	0
-0.013440	-0.200000	-0.040980	0	0.884530	-0.200000	0.000000	0	-0.137175	-0.300000	0.026795	0
-0.033790	-0.200000	-0.037733	0	0.892331	-0.200000	0.000000	0	-0.124445	-0.300000	0.030571	0
-0.051520	-0.200000	-0.034243	0	0.904531	-0.200000	0.000000	0	-0.109265	-0.300000	0.034243	0
-0.066700	-0.200000	-0.030571	0	0.934530	-0.200000	0.000000	0	-0.091525	-0.300000	0.037733	0
-0.079440	-0.200000	-0.026803	0	0.826795	-0.300000	0.000000	1	-0.071185	-0.300000	0.040972	0
-0.089860	-0.200000	-0.022984	0	0.824695	-0.300000	-0.000260	0	-0.048205	-0.300000	0.043906	0
-0.098130	-0.200000	-0.019200	0	0.810425	-0.300000	-0.001031	0	-0.022615	-0.300000	0.046462	0
-0.104450	-0.200000	-0.015519	0	0.808045	-0.300000	-0.002295	0	0.005545	-0.300000	0.048575	0
-0.109040	-0.200000	-0.011986	0	0.793655	-0.300000	-0.004027	0	0.036185	-0.300000	0.050212	0
-0.112160	-0.200000	-0.008695	0	0.775405	-0.300000	-0.006175	0	0.069165	-0.300000	0.051329	0
-0.114070	-0.200000	-0.005716	0	0.753445	-0.300000	-0.008695	0	0.104325	-0.300000	0.051901	0
-0.115050	-0.200000	-0.003135	0	0.728015	-0.300000	-0.011535	0	0.141445	-0.300000	0.051901	0
-0.115420	-0.200000	-0.001117	0	0.699345	-0.300000	-0.014636	0	0.180335	-0.300000	0.051390	0
-0.115420	-0.200000	0.000000	0	0.667715	-0.300000	-0.017935	0	0.220705	-0.300000	0.048792	0
-0.114070	-0.200000	0.001117	0	0.633625	-0.300000	-0.021302	0	0.262255	-0.300000	0.048792	0
-0.115050	-0.200000	0.003135	0	0.596785	-0.300000	-0.024907	0	0.304685	-0.300000	0.046791	0
-0.114070	-0.200000	0.005716	0	0.558155	-0.300000	-0.028449	0	0.347665	-0.300000	0.044392	0
-0.112160	-0.200000	0.008695	0	0.517875	-0.300000	-0.031965	0	0.390835	-0.300000	0.041647	0
-0.109040	-0.200000	0.011986	0	0.476315	-0.300000	-0.035368	0	0.433835	-0.300000	0.038625	0
-0.104450	-0.200000	0.015519	0	0.438845	-0.300000	-0.038625	0	0.476305	-0.300000	0.035368	0
-0.098130	-0.200000	0.019200	0	0.390845	-0.300000	-0.041647	0	0.517865	-0.300000	0.031965	0
-0.090860	-0.200000	0.022984	0	0.347675	-0.300000	-0.044392	0	0.558145	-0.300000	0.028449	0
-0.079440	-0.200000	0.026795	0	0.304695	-0.300000	-0.046791	0	0.596775	-0.300000	0.024907	0
-0.066710	-0.200000	0.030571	0	0.262265	-0.300000	-0.048792	0	0.633415	-0.300000	0.021302	0
-0.051530	-0.200000	0.034243	0	0.220715	-0.300000	-0.050333	0	0.667705	-0.300000	0.019200	0
-0.033790	-0.200000	0.037733	0	0.180355	-0.300000	-0.051390	0	0.699335	-0.300000	0.017935	0
-0.013440	-0.200000	0.040972	0	0.141465	-0.300000	-0.051918	0	0.728005	-0.300000	0.016636	0
0.009530	-0.200000	0.043906	0	0.104335	-0.300000	-0.051901	0	0.753445	-0.300000	0.015535	0
0.035120	-0.200000	0.046462	0	0.069175	-0.300000	-0.051329	0	0.775395	-0.300000	0.014636	0
0.063280	-0.200000	0.048575	0	0.036195	-0.300000	-0.050212	0	0.793655	-0.300000	0.013965	0
0.093920	-0.200000	0.050212	0	-0.002555	-0.300000	-0.048575	0	0.808045	-0.300000	0.013029	0
0.126900	-0.200000	0.051329	0	-0.022605	-0.300000	-0.046462	0	0.810425	-0.300000	0.012660	0
0.162060	-0.200000	0.051901	0	-0.048205	-0.300000	-0.043908	0	0.824695	-0.300000	0.012295	0
0.199190	-0.200000	0.051918	0	-0.071175	-0.300000	-0.040980	0	0.846796	-0.300000	0.012000	0
0.238070	-0.200000	0.051390	0	-0.091525	-0.300000	-0.037733	0	0.866795	-0.300000	0.011831	0
0.278440	-0.200000	0.050342	0	-0.109255	-0.300000	-0.034243	0	0.876795	-0.300000	0.011535	0
0.319990	-0.200000	0.048792	0	-0.124435	-0.300000	-0.030571	0	0.886796	-0.300000	0.011390	0
0.362420	-0.200000	0.046791	0	-0.137175	-0.300000	-0.026803	0	0.896795	-0.300000	0.011260	0
0.405600	-0.200000	0.044392	0	-0.147595	-0.300000	-0.022984	0	0.906795	-0.300000	0.011131	0
0.448570	-0.200000	0.041647	0	-0.155865	-0.300000	-0.019208	0	0.916795	-0.300000	0.011000	0
0.491570	-0.200000	0.038625	0	-0.162185	-0.300000	-0.015519	0	0.926795	-0.300000	0.010870	0
0.534040	-0.200000	0.035368	0	-0.166775	-0.300000	-0.011986	0	0.936795	-0.300000	0.010740	0
0.575600	-0.200000	0.031965	0	-0.169895	-0.300000	-0.008695	0	0.946795	-0.300000	0.010610	0
0.615800	-0.200000	0.028449	0	-0.171805	-0.300000	-0.006175	0	0.956795	-0.300000	0.010480	0
0.654510	-0.200000	0.024907	0	-0.172785	-0.300000	-0.004027	0	0.966795	-0.300000	0.010350	0
0.691150	-0.200000	0.021302	0	-0.173155	-0.300000	-0.003135	0	0.976795	-0.300000	0.010220	0
0.725460	-0.200000	0.017935	0	-0.173205	-0.300000	-0.001117	0	0.986795	-0.300000	0.010090	0
0.757070	-0.200000	0.014636	0	-0.172785	-0.300000	0.000000	0	0.996795	-0.300000	0.009960	0
0.785740	-0.200000	0.011535	0	-0.172785	-0.300000	0.001117	0	1.006795	-0.300000	0.009830	0
0.811180	-0.200000	0.008695	0	-0.171805	-0.300000	0.003135	0	1.016795	-0.300000	0.009700	0
0.833130	-0.200000	0.006175	0	-0.169895	-0.300000	0.005116	0	1.026795	-0.300000	0.009570	0
0.851390	-0.200000	0.004027	0	-0.166775	-0.300000	0.007117	0	1.036795	-0.300000	0.009440	0
0.865780	-0.200000	0.002295	0	-0.162185	-0.300000	0.009118	0	1.046795	-0.300000	0.009310	0

Figure 25. - Continued.

0.333110	-0.400000	-0.041647	0	0.660130	-0.400000	0.031965	0	-0.285365	-0.500000	-0.008695	0
0.289940	-0.400000	-0.046392	0	0.500410	-0.400000	0.028458	0	-0.207275	-0.500000	-0.005716	0
0.246960	-0.400000	-0.046791	0	0.539040	-0.400000	0.024907	0	-0.208255	-0.500000	-0.003135	0
0.204530	-0.400000	-0.048792	0	0.575640	-0.400000	0.021382	0	-0.208625	-0.500000	-0.001117	0
0.162980	-0.400000	-0.050333	0	0.609970	-0.400000	0.017935	0	-0.208675	-0.500000	0.000000	0
0.122620	-0.400000	-0.051330	0	0.641600	-0.400000	0.014636	0	-0.208625	-0.500000	0.001117	0
0.083730	-0.400000	-0.051910	0	0.670270	-0.400000	0.011535	0	-0.208275	-0.500000	0.003135	0
0.046600	-0.400000	-0.051901	0	0.695710	-0.400000	0.008695	0	-0.205365	-0.500000	0.005716	0
0.011460	-0.400000	-0.051329	0	0.717660	-0.400000	0.006175	0	-0.202245	-0.500000	0.008695	0
-0.021540	-0.400000	-0.050212	0	0.735920	-0.400000	0.004029	0	-0.207655	-0.500000	0.011986	0
-0.048575	-0.400000	-0.048575	0	0.750310	-0.400000	0.002295	0	-0.271335	-0.500000	0.015519	0
-0.046462	-0.400000	-0.046462	0	0.766960	-0.400000	0.001031	0	-0.273065	-0.500000	0.019200	0
-0.043908	-0.400000	-0.043908	0	0.769060	-0.400000	0.000260	0	-0.263065	-0.500000	0.022984	0
-0.040980	-0.400000	-0.040980	0	0.777061	-0.400000	0.000000	0	-0.252645	-0.500000	0.026795	0
-0.037733	-0.400000	-0.037733	0	0.789061	-0.400000	0.000000	0	-0.259915	-0.500000	0.030571	0
-0.034243	-0.400000	-0.034243	0	0.819060	-0.400000	0.000000	0	-0.224735	-0.500000	0.034243	0
-0.030571	-0.400000	-0.030571	0	0.819060	-0.400000	0.000000	0	-0.206695	-0.500000	0.037733	0
-0.028683	-0.400000	-0.028683	0	0.711325	-0.500000	0.000000	1	-0.163675	-0.500000	0.040972	0
-0.022984	-0.400000	-0.022984	0	0.709225	-0.500000	-0.000260	0	-0.138085	-0.500000	0.043908	0
-0.019208	-0.400000	-0.019208	0	0.729255	-0.500000	-0.002295	0	-0.109925	-0.500000	0.046462	0
-0.015519	-0.400000	-0.015519	0	0.678105	-0.500000	-0.006402	0	-0.079285	-0.500000	0.050212	0
-0.011986	-0.400000	-0.011986	0	0.659035	-0.500000	-0.006175	0	-0.063005	-0.500000	0.051329	0
-0.008695	-0.400000	-0.008695	0	0.637975	-0.500000	-0.008695	0	-0.041145	-0.500000	0.051901	0
-0.005716	-0.400000	-0.005716	0	0.612545	-0.500000	-0.011535	0	0.025985	-0.500000	0.051918	0
-0.003135	-0.400000	-0.003135	0	0.583875	-0.500000	-0.014636	0	0.064865	-0.500000	0.051390	0
-0.001117	-0.400000	-0.001117	0	0.552245	-0.500000	-0.017935	0	0.105235	-0.500000	0.050342	0
0.000000	-0.400000	0.000000	0	0.517965	-0.500000	-0.021382	0	0.146785	-0.500000	0.048792	0
0.000000	-0.400000	0.000000	0	0.481315	-0.500000	-0.024907	0	0.182125	-0.500000	0.046791	0
0.000000	-0.400000	0.000000	0	0.442405	-0.500000	-0.031965	0	0.232195	-0.500000	0.044392	0
0.000000	-0.400000	0.000000	0	0.402405	-0.500000	-0.034965	0	0.275365	-0.500000	0.041647	0
0.000000	-0.400000	0.000000	0	0.360845	-0.500000	-0.035368	0	0.318365	-0.500000	0.038625	0
0.000000	-0.400000	0.000000	0	0.318375	-0.500000	-0.038625	0	0.360835	-0.500000	0.035368	0
0.000000	-0.400000	0.000000	0	0.275375	-0.500000	-0.041647	0	0.402395	-0.500000	0.031965	0
0.000000	-0.400000	0.000000	0	0.232205	-0.500000	-0.044392	0	0.442675	-0.500000	0.028458	0
0.000000	-0.400000	0.000000	0	0.189225	-0.500000	-0.046791	0	0.481305	-0.500000	0.024907	0
0.000000	-0.400000	0.000000	0	0.146795	-0.500000	-0.060792	0	0.517945	-0.500000	0.021382	0
0.000000	-0.400000	0.000000	0	0.105265	-0.500000	-0.050333	0	0.552335	-0.500000	0.017935	0
0.000000	-0.400000	0.000000	0	0.064885	-0.500000	-0.051390	0	0.583865	-0.500000	0.014636	0
0.000000	-0.400000	0.000000	0	-0.025995	-0.500000	-0.051918	0	0.612535	-0.500000	0.011535	0
0.000000	-0.400000	0.000000	0	-0.011135	-0.500000	-0.051901	0	0.637975	-0.500000	0.011535	0
0.000000	-0.400000	0.000000	0	-0.046295	-0.500000	-0.051329	0	0.659025	-0.500000	0.006175	0
0.000000	-0.400000	0.000000	0	-0.079275	-0.500000	-0.050212	0	0.678185	-0.500000	0.004029	0
0.000000	-0.400000	0.000000	0	-0.109915	-0.500000	-0.048575	0	0.692375	-0.500000	0.002295	0
0.000000	-0.400000	0.000000	0	-0.138075	-0.500000	-0.046462	0	0.702955	-0.500000	0.001031	0
0.000000	-0.400000	0.000000	0	-0.163675	-0.500000	-0.043908	0	0.709225	-0.500000	0.000260	0
0.000000	-0.400000	0.000000	0	-0.186645	-0.500000	-0.040980	0	0.711325	-0.500000	0.000000	0
0.000000	-0.400000	0.000000	0	-0.206995	-0.500000	-0.037733	0	0.719326	-0.500000	0.000000	0
0.000000	-0.400000	0.000000	0	-0.224725	-0.500000	-0.034243	0	0.731326	-0.500000	0.000000	0
0.000000	-0.400000	0.000000	0	-0.239905	-0.500000	-0.030571	0	0.761325	-0.500000	0.000000	0
0.000000	-0.400000	0.000000	0	-0.252645	-0.500000	-0.026803	0	0.653590	-0.600000	0.000000	1
0.000000	-0.400000	0.000000	0	-0.263065	-0.500000	-0.022984	0	0.651690	-0.600000	-0.000260	0
0.000000	-0.400000	0.000000	0	-0.271335	-0.500000	-0.019208	0	0.645220	-0.600000	-0.001031	0
0.000000	-0.400000	0.000000	0	-0.277655	-0.500000	-0.015519	0	0.634040	-0.600000	-0.002295	0
0.000000	-0.400000	0.000000	0	-0.282245	-0.500000	-0.011986	0	0.620450	-0.600000	-0.004029	0

Figure 25. - Continued.

0.602200	-0.600000	-0.006175	0	-0.104040	-0.600000	0.051329	0	-0.253545	-0.700000	-0.046462	0
0.580240	-0.600000	-0.008695	0	-0.068880	-0.600000	0.051901	0	-0.279145	-0.700000	-0.043900	0
0.554610	-0.600000	-0.011535	0	-0.031750	-0.600000	0.051918	0	-0.302115	-0.700000	-0.040980	0
0.526140	-0.600000	-0.014636	0	0.007130	-0.600000	0.051390	0	-0.322465	-0.700000	-0.037733	0
0.494510	-0.600000	-0.017935	0	0.047500	-0.600000	0.050342	0	-0.350195	-0.700000	-0.034243	0
0.460220	-0.600000	-0.021382	0	0.089050	-0.600000	0.048792	0	-0.355375	-0.700000	-0.030571	0
0.423580	-0.600000	-0.024907	0	0.131480	-0.600000	0.046791	0	-0.360115	-0.700000	-0.026803	0
0.384930	-0.600000	-0.028449	0	0.174460	-0.600000	0.044392	0	-0.378535	-0.700000	-0.022984	0
0.344670	-0.600000	-0.031965	0	0.217630	-0.600000	0.041647	0	-0.393125	-0.700000	-0.015519	0
0.303110	-0.600000	-0.035368	0	0.240630	-0.600000	0.038625	0	-0.397715	-0.700000	-0.011986	0
0.260640	-0.600000	-0.038625	0	0.303100	-0.600000	0.035368	0	-0.400835	-0.700000	-0.008695	0
0.217640	-0.600000	-0.041647	0	0.346660	-0.600000	0.031965	0	-0.402745	-0.700000	-0.005716	0
0.174470	-0.600000	-0.044392	0	0.384940	-0.600000	0.028449	0	-0.403725	-0.700000	-0.003135	0
0.131490	-0.600000	-0.046791	0	0.423570	-0.600000	0.024907	0	-0.404095	-0.700000	-0.001117	0
0.089060	-0.600000	-0.048792	0	0.460210	-0.600000	0.021382	0	-0.404145	-0.700000	0.000000	0
0.047510	-0.600000	-0.050342	0	0.494500	-0.600000	0.017935	0	-0.404095	-0.700000	0.000000	0
0.007150	-0.600000	-0.051390	0	0.526130	-0.600000	0.014636	0	-0.404095	-0.700000	0.000000	0
-0.031740	-0.600000	-0.051918	0	0.554880	-0.600000	0.011535	0	-0.403725	-0.700000	0.000000	0
-0.068870	-0.600000	-0.051901	0	0.580240	-0.600000	0.008695	0	-0.402745	-0.700000	0.000000	0
-0.104030	-0.600000	-0.051329	0	0.602190	-0.600000	0.006175	0	-0.400835	-0.700000	0.000000	0
-0.137010	-0.600000	-0.050212	0	0.620450	-0.600000	0.004027	0	-0.397715	-0.700000	0.000000	0
-0.167450	-0.600000	-0.048575	0	0.634840	-0.600000	0.002295	0	-0.393125	-0.700000	0.000000	0
-0.195010	-0.600000	-0.046462	0	0.645220	-0.600000	0.001031	0	-0.386805	-0.700000	0.000000	0
-0.221410	-0.600000	-0.043908	0	0.651490	-0.600000	0.000260	0	-0.378535	-0.700000	0.000000	0
-0.244380	-0.600000	-0.040980	0	0.653590	-0.600000	0.000000	0	-0.368115	-0.700000	0.000000	0
-0.264730	-0.600000	-0.037733	0	0.661591	-0.600000	0.000000	0	-0.355385	-0.700000	0.000000	0
-0.282460	-0.600000	-0.034243	0	0.673591	-0.600000	0.000000	0	-0.340205	-0.700000	0.000000	0
-0.297640	-0.600000	-0.030571	0	0.703590	-0.600000	0.000000	0	-0.322465	-0.700000	0.000000	0
-0.310380	-0.600000	-0.026803	0	0.735855	-0.700000	0.000000	1	-0.302125	-0.700000	0.000000	0
-0.320800	-0.600000	-0.022984	0	0.593755	-0.700000	0.000260	0	-0.279145	-0.700000	0.000000	0
-0.329070	-0.600000	-0.019208	0	0.587405	-0.700000	0.000000	0	-0.253555	-0.700000	0.000000	0
-0.335390	-0.600000	-0.015519	0	0.577105	-0.700000	0.001031	0	-0.223595	-0.700000	0.000000	0
-0.339980	-0.600000	-0.011986	0	0.562715	-0.700000	0.004027	0	-0.194755	-0.700000	0.000000	0
-0.343100	-0.600000	-0.008695	0	0.544465	-0.700000	0.006175	0	-0.161775	-0.700000	0.000000	0
-0.345010	-0.600000	-0.005716	0	0.522505	-0.700000	0.008695	0	-0.126615	-0.700000	0.000000	0
-0.345990	-0.600000	-0.003135	0	0.497075	-0.700000	0.011535	0	-0.089685	-0.700000	0.000000	0
-0.346360	-0.600000	-0.001117	0	0.468405	-0.700000	0.014636	0	-0.050605	-0.700000	0.000000	0
-0.346410	-0.600000	0.000000	0	0.436775	-0.700000	0.017935	0	-0.010235	-0.700000	0.000000	0
-0.346360	-0.600000	0.001117	0	0.402405	-0.700000	0.021382	0	0.031315	-0.700000	0.000000	0
-0.345990	-0.600000	0.003135	0	0.365845	-0.700000	0.024907	0	0.073745	-0.700000	0.000000	0
-0.345010	-0.600000	0.005716	0	0.327215	-0.700000	0.028449	0	0.116725	-0.700000	0.000000	0
-0.343100	-0.600000	0.008695	0	0.286935	-0.700000	0.031965	0	0.159895	-0.700000	0.000000	0
-0.339980	-0.600000	0.011986	0	0.245375	-0.700000	0.035368	0	0.202095	-0.700000	0.000000	0
-0.335390	-0.600000	0.015519	0	0.202905	-0.700000	0.038625	0	0.245365	-0.700000	0.000000	0
-0.329070	-0.600000	0.019208	0	0.159905	-0.700000	0.041647	0	0.286925	-0.700000	0.000000	0
-0.320800	-0.600000	0.022984	0	0.116735	-0.700000	0.044392	0	0.327205	-0.700000	0.000000	0
-0.310380	-0.600000	0.026795	0	0.073755	-0.700000	0.046791	0	0.365835	-0.700000	0.000000	0
-0.297650	-0.600000	0.030571	0	-0.031325	-0.700000	0.048792	0	0.402475	-0.700000	0.000000	0
-0.282470	-0.600000	0.034243	0	-0.010225	-0.700000	0.050342	0	0.436765	-0.700000	0.000000	0
-0.264730	-0.600000	0.037733	0	-0.0050585	-0.700000	0.051390	0	0.468395	-0.700000	0.000000	0
-0.244390	-0.600000	0.040980	0	0.0089475	-0.700000	0.051918	0	0.497065	-0.700000	0.000000	0
-0.221410	-0.600000	0.043908	0	-0.126665	-0.700000	0.051901	0	0.522505	-0.700000	0.000000	0
-0.195020	-0.600000	0.046462	0	-0.161765	-0.700000	0.051329	0	0.544455	-0.700000	0.000000	0
-0.167660	-0.600000	0.048575	0	-0.194745	-0.700000	0.050212	0	0.562715	-0.700000	0.000000	0
-0.137020	-0.600000	0.050212	0	-0.225385	-0.700000	0.048575	0	0.577105	-0.700000	0.002295	0

Figure 25. - Concluded.

EPS(1)= 2.0000E-07
 EPS(2)= 2.0000E-07
 EPS(3)= 2.0000E-07

PARTICLE FLUX TUBE SPECIFICATIONS -

NUMBER OF TRAJECTORIES ON FLUX TUBE PERIPHERY= 0
 FLUX TUBE RADIUS AT TARGET= 0.10000
 TOLERANCE= 0.0200

TANGENT TRAJECTORY TOLERANCE(SUB IMPLIM) -

FINE INCREMENT= 1.00000E-04

BETA CALCULATION INPUTS (NAMELIST IMPING)

IRUN=	5				
IFLOW=	1				
IRES=	0				
ICE=	1				
ISTRF=	0				
ICEC=	3				
DSHIFT=	0.002000				
SHFTF=	0.000000				
	SECTION NUMBER; 1				
NBR;	20				
NBC;	1				
NPSEC;	2				
XSEC;	0.000000	YSEC;	0.000000	ZSEC;	0.0700000
XSEC;	0.000000	YSEC;	0.000000	ZSEC;	-0.0500000
SECTION NUMBER; 2					
NBR;	20				
NBC;	1				
NPSEC;	2				
XSEC;	0.3180000	YSEC;	0.5500000	ZSEC;	0.0500000
XSEC;	0.3180000	YSEC;	0.5500000	ZSEC;	-0.0600000
SECTION NUMBER; 3					
NBR;	20				
NBC;	1				
NPSEC;	2				
XSEC;	-0.3180000	YSEC;	-0.5500000	ZSEC;	0.0500000
XSEC;	-0.3180000	YSEC;	-0.5500000	ZSEC;	-0.0600000

LEWICED2 CALCULATION INPUTS (NAMELIST ICEIN)

Figure 26. - Continued.

AMBIENT TEMPERATURE; TAMB= 2.670000E+02
 AMBIENT PRESSURE; PAMB= 8.987600E+04
 RELATIVE HUMIDITY; RH= 1.000000E+02
 LIQUID WATER CONTENT; LWC= 7.500000E-01
 SEGMENT GROWTH TOLERANCE; SEGTL= 1.500000E+00
 ROUGHNESS PARAMETER; XKINIT= 4.500000E-03
 ICING TIME; TSTOP= 1.200000E+02
 FLOWFIELD TIME STEP; DTFLW= 1.200000E+02
 ICING TIME STEP; DTIME= 1.200000E+02

*** SUBROUTINE READIN COMPLETE ***

CPU TIME = 0.375

*** SUBROUTINE FLOW COMPLETE ***

CPU TIME = 89.934

SUBROUTINE STREM3D OUTPUT FOR SLICE: 1

POINT	XSTRM	YSTRM	ZSTRM	SSTRM	XNSTRM	YNSTRM	ZNSTRM	CFSTRM	VSTRM	BSTRM
1	1.669816	0.006338	-0.000562	1.697766	0.000000	0.000000	0.000000	0.016496	0.991718	0.000000
2	1.448139	0.005533	-0.000565	1.476087	0.000000	0.000000	0.000000	0.027045	0.986385	0.000000
3	1.301231	0.004380	-0.000569	1.329174	0.000000	0.000000	0.000000	0.039622	0.979989	0.000000
4	1.203976	0.003159	-0.000574	1.231912	0.000000	0.000000	0.000000	0.053859	0.972698	0.000000
5	1.139652	0.002010	-0.000581	1.167577	0.000000	0.000000	0.000000	0.069321	0.964717	0.000000
6	1.097156	0.001011	-0.000580	1.125049	0.000000	0.000000	0.000000	0.085382	0.956357	0.000000
7	1.069044	0.000189	-0.000595	1.096945	0.000000	0.000000	0.000000	0.101269	0.948014	0.000000
8	1.050480	-0.000458	-0.000602	1.078370	0.000000	0.000000	0.000000	0.116255	0.940077	0.000000
9	1.038206	-0.000951	-0.000608	1.066086	0.000000	0.000000	0.000000	0.129730	0.932883	0.000000
10	1.026046	-0.001512	-0.000617	1.053915	0.000000	0.000000	0.000000	0.148155	0.922955	0.000000
11	1.018027	-0.001937	-0.000626	1.045883	0.000000	0.000000	0.000000	0.165441	0.913542	0.000000
12	1.012736	-0.002252	-0.000635	1.040582	0.000000	0.000000	0.000000	0.181125	0.904917	0.000000
13	1.009241	-0.002482	-0.000642	1.037080	0.000000	0.000000	0.000000	0.194818	0.897319	0.000000
14	1.005782	-0.002732	-0.000654	1.033612	0.000000	0.000000	0.000000	0.213038	0.887109	0.000000
15	1.003503	-0.002914	-0.000665	1.031326	0.000000	0.000000	0.000000	0.229878	0.877566	0.000000
16	1.002000	-0.003046	-0.000674	1.029817	0.000000	0.000000	0.000000	0.244915	0.868956	0.000000
17	1.000516	-0.003188	-0.000687	1.028326	0.000000	0.000000	0.000000	0.264902	0.857378	0.000000
18	0.999057	-0.003344	-0.000714	1.026859	0.000000	0.000000	0.000000	0.289497	0.842913	0.000000
19	0.997610	-0.003508	-0.000784	1.025400	0.000000	0.000000	0.000000	0.283385	0.846531	0.000000
20	0.992441	-0.004017	-0.001314	1.020180	0.000000	0.000000	0.000000	0.222920	0.881521	0.000000
21	0.982383	-0.004744	-0.002462	1.010030	0.000000	0.000000	0.000000	0.167957	0.912164	0.000000
22	0.962954	-0.005749	-0.004706	0.990446	0.000000	0.000000	0.000000	0.117111	0.939622	0.000000
23	0.925515	-0.007003	-0.008947	0.952747	0.000000	0.000000	0.000000	0.064996	0.966956	0.000000

Figure 26. - Continued.

24	0.853343	-0.016705	0.880151	0.000000	0.000000	0.006939	0.996524	0.000000
25	0.779334	-0.024090	0.805774	0.000000	0.000000	-0.035808	1.016996	0.000000
26	0.729186	-0.028737	0.755409	0.000000	0.000000	-0.058080	1.028984	0.000000
27	0.678471	-0.033163	0.704498	0.000000	0.000000	-0.081022	1.053722	0.000000
28	0.627215	-0.037319	0.653066	0.000000	0.000000	-0.101775	1.049655	0.000000
29	0.575367	-0.041122	0.601084	0.000000	0.000000	-0.123734	1.060063	0.000000
30	0.540548	-0.043449	0.566154	0.000000	0.000000	-0.138283	1.064903	0.000000
31	0.505475	-0.045633	0.530996	0.000000	0.000000	-0.153804	1.074153	0.000000
32	0.481971	-0.046953	0.507441	0.000000	0.000000	-0.165641	1.079649	0.000000
33	0.458345	-0.048147	0.483770	0.000000	0.000000	-0.173884	1.083460	0.000000
34	0.434608	-0.049244	0.459990	0.000000	0.000000	-0.193606	1.092523	0.000000
35	0.410762	-0.050175	0.436105	0.000000	0.000000	-0.194790	1.093065	0.000000
36	0.386803	-0.051005	0.412108	0.000000	0.000000	-0.207246	1.098748	0.000000
37	0.370784	-0.051442	0.396067	0.000000	0.000000	-0.212610	1.101186	0.000000
38	0.354700	-0.051826	0.379959	0.000000	0.000000	-0.229476	1.108818	0.000000
39	0.338569	-0.052081	0.363806	0.000000	0.000000	-0.226917	1.107663	0.000000
40	0.327800	-0.052223	0.353023	0.000000	0.000000	-0.232857	1.110391	0.000000
41	0.316991	-0.052333	0.342199	0.000000	0.000000	-0.246026	1.116255	0.000000
42	0.306165	-0.052358	0.331357	0.000000	0.000000	-0.242031	1.114464	0.000000
43	0.295335	-0.052354	0.320512	0.000000	0.000000	-0.246145	1.116309	0.000000
44	0.284474	-0.052324	0.309635	0.000000	0.000000	-0.258130	1.121664	0.000000
45	0.273575	-0.052195	0.298718	0.000000	0.000000	-0.257496	1.121381	0.000000
46	0.259998	-0.051974	0.285117	0.000000	0.000000	-0.261197	1.123030	0.000000
47	0.234476	-0.051296	0.259542	0.000000	0.000000	-0.270922	1.127352	0.000000
48	0.208906	-0.050273	0.233906	0.000000	0.000000	-0.282892	1.132648	0.000000
49	0.191839	-0.049327	0.216781	0.000000	0.000000	-0.289769	1.135680	0.000000
50	0.174718	-0.048112	0.199583	0.000000	0.000000	-0.290295	1.135912	0.000000
51	0.163316	-0.047210	0.188123	0.000000	0.000000	-0.300058	1.140201	0.000000
52	0.151894	-0.046119	0.176627	0.000000	0.000000	-0.297329	1.139003	0.000000
53	0.144300	-0.045361	0.168979	0.000000	0.000000	-0.296820	1.138780	0.000000
54	0.130066	-0.043753	0.154628	0.000000	0.000000	-0.302988	1.141485	0.000000
55	0.115896	-0.041881	0.140308	0.000000	0.000000	-0.305429	1.142554	0.000000
56	0.101759	-0.039669	0.125975	0.000000	0.000000	-0.293872	1.137485	0.000000
57	0.092371	-0.038065	0.116435	0.000000	0.000000	-0.298894	1.139690	0.000000
58	0.083048	-0.036245	0.105922	0.000000	0.000000	-0.284371	1.133301	0.000000
59	0.076853	-0.034864	0.100588	0.000000	0.000000	-0.291020	1.136231	0.000000
60	0.070708	-0.033545	0.094274	0.000000	0.000000	-0.272740	1.128150	0.000000
61	0.066642	-0.032544	0.090082	0.000000	0.000000	-0.265891	1.125118	0.000000
62	0.059074	-0.030563	0.082252	0.000000	0.000000	-0.249559	1.117837	0.000000
63	0.054110	-0.029099	0.077075	0.000000	0.000000	-0.238185	1.112738	0.000000
64	0.050819	-0.028096	0.073633	0.000000	0.000000	-0.240424	1.113743	0.000000
65	0.048629	-0.027417	0.071339	0.000000	0.000000	-0.234183	1.110938	0.000000
66	0.047187	-0.026937	0.069819	0.000000	0.000000	-0.208512	1.099323	0.000000
67	0.045764	-0.026433	0.068309	0.000000	0.000000	-0.204593	1.097540	0.000000
68	0.043114	-0.025475	0.065491	0.000000	0.000000	-0.194907	1.093118	0.000000
69	0.041359	-0.024826	0.063620	0.000000	0.000000	-0.190248	1.090985	0.000000
70	0.040192	-0.024388	0.062373	0.000000	0.000000	-0.189550	1.090665	0.000000
71	0.039029	-0.023946	0.061129	0.000000	0.000000	-0.183164	1.087733	0.000000
72	0.037485	-0.023353	0.059475	0.000000	0.000000	-0.162264	1.078084	0.000000
73	0.035983	-0.022718	0.057844	0.000000	0.000000	-0.136403	1.066022	0.000000
74	0.034595	-0.022106	0.056327	0.000000	0.000000	-0.133660	1.064641	0.000000
75	0.033672	-0.021695	0.055317	0.000000	0.000000	-0.128271	1.062201	0.000000
76	0.031958	-0.020918	0.053434	0.000000	0.000000	-0.120858	1.058706	0.000000
77	0.030261	-0.020126	0.051561	0.000000	0.000000	-0.1051302	1.051302	0.000000
78	0.028586	-0.019331	0.049706	0.000000	0.000000	-0.064211	1.031606	0.000000

Figure 26. - Continued.

79	0.026994	0.019986	-0.018674	0.047894	0.000000	0.000000	0.000000	-0.033112	1.016421	0.000000
80	0.025043	0.019826	-0.017375	0.045649	0.000000	0.000000	0.000000	-0.019929	1.009916	0.000000
81	0.023762	0.019708	-0.016638	0.044166	0.000000	0.000000	0.000000	0.0001692	0.999154	0.000000
82	0.022499	0.019579	-0.015901	0.042699	0.000000	0.000000	0.000000	0.020043	0.989928	0.000000
83	0.021278	0.019426	-0.015187	0.041276	0.000000	0.000000	0.000000	0.104631	0.946239	0.000000
84	0.020514	0.019296	-0.014676	0.040367	0.000000	0.000000	0.000000	0.112775	0.941926	0.000000
85	0.019115	0.019034	-0.013698	0.038621	0.000000	0.000000	0.000000	0.131895	0.931721	0.000000
86	0.018201	0.018849	-0.013051	0.037486	0.000000	0.000000	0.000000	0.155386	0.919029	0.000000
87	0.017295	0.018660	-0.012421	0.036366	0.000000	0.000000	0.000000	0.177415	0.906965	0.000000
88	0.016659	0.018429	-0.011785	0.035291	0.000000	0.000000	0.000000	0.206519	0.850577	0.000000
89	0.015016	0.017930	-0.010604	0.033360	0.000000	0.000000	0.000000	0.306011	0.833060	0.000000
90	0.014090	0.017576	-0.009820	0.032096	0.000000	0.000000	0.000000	0.329593	0.818784	0.000000
91	0.013179	0.017214	-0.009071	0.030863	0.000000	0.000000	0.000000	0.385611	0.783830	0.000000
92	0.012365	0.016795	-0.008364	0.029706	0.000000	0.000000	0.000000	0.469861	0.728107	0.000000
93	0.010929	0.015963	-0.007160	0.027656	0.000000	0.000000	0.000000	0.502267	0.705502	0.000000
94	0.009599	0.015070	-0.006047	0.025795	0.000000	0.000000	0.000000	0.571289	0.654822	0.000000
95	0.007443	0.013209	-0.004407	0.022419	0.000000	0.000000	0.000000	0.652293	0.589667	0.000000
96	0.003744	0.009537	-0.002468	0.016858	0.000000	0.000000	0.000000	0.711750	0.536889	0.000000
97	-0.000123	0.005964	-0.001497	0.011504	0.000000	0.000000	0.000000	0.706574	0.541689	0.000000
98	-0.004637	0.002766	-0.001016	0.005951	0.000000	0.000000	0.000000	0.670938	0.573639	0.000000
99	-0.009900	0.000000	-0.000769	0.000000	0.000000	0.000000	0.000000	0.617250	0.618660	0.000000
100	-0.009900	0.000000	0.002308	0.000000	0.000000	0.000000	0.000000	0.610719	0.623924	0.000000
101	-0.004561	0.002722	0.003035	0.006037	0.000000	0.000000	0.000000	0.655191	0.623924	0.000000
102	0.000160	0.005801	0.004417	0.011840	0.000000	0.000000	0.000000	0.588794	0.584128	0.000000
103	0.004699	0.008986	0.007033	0.017971	0.000000	0.000000	0.000000	0.658794	0.584128	0.000000
104	0.010150	0.011646	0.011211	0.025337	0.000000	0.000000	0.000000	0.56579	0.662888	0.000000
105	0.013796	0.012647	0.013835	0.029939	0.000000	0.000000	0.000000	0.323668	0.822394	0.000000
106	0.017970	0.013344	0.016520	0.034950	0.000000	0.000000	0.000000	0.180401	0.905317	0.000000
107	0.022599	0.013778	0.019110	0.040272	0.000000	0.000000	0.000000	0.064872	0.967020	0.000000
108	0.027561	0.014021	0.021530	0.045799	0.000000	0.000000	0.000000	-0.029675	1.014729	0.000000
109	0.032756	0.014129	0.023801	0.051469	0.000000	0.000000	0.000000	-0.104821	1.051105	0.000000
110	0.038162	0.014116	0.025885	0.057263	0.000000	0.000000	0.000000	-0.148013	1.071454	0.000000
111	0.043684	0.014037	0.027838	0.063120	0.000000	0.000000	0.000000	-0.183898	1.088071	0.000000
112	0.049335	0.013883	0.029621	0.069048	0.000000	0.000000	0.000000	-0.216378	1.102895	0.000000
113	0.055045	0.013696	0.031302	0.075003	0.000000	0.000000	0.000000	-0.231042	1.109523	0.000000
114	0.063759	0.013530	0.033577	0.084017	0.000000	0.000000	0.000000	-0.252027	1.118960	0.000000
115	0.072564	0.012912	0.035662	0.093075	0.000000	0.000000	0.000000	-0.263066	1.123871	0.000000
116	0.081450	0.012448	0.037508	0.102163	0.000000	0.000000	0.000000	-0.208205	1.134991	0.000000
117	0.094891	0.011690	0.040000	0.115854	0.000000	0.000000	0.000000	-0.283107	1.137473	0.000000
118	0.108390	0.010900	0.042162	0.129547	0.000000	0.000000	0.000000	-0.292961	1.137084	0.000000
119	0.121949	0.010077	0.044018	0.143258	0.000000	0.000000	0.000000	-0.305643	1.142667	0.000000
120	0.142387	0.008788	0.046354	0.163869	0.000000	0.000000	0.000000	-0.295843	1.138351	0.000000
121	0.162833	0.007498	0.048307	0.184449	0.000000	0.000000	0.000000	-0.294798	1.137892	0.000000
122	0.183248	0.006230	0.049834	0.204960	0.000000	0.000000	0.000000	-0.293695	1.137407	0.000000
123	0.203639	0.004979	0.051008	0.225423	0.000000	0.000000	0.000000	-0.298454	1.139497	0.000000
124	0.224031	0.003731	0.051880	0.245872	0.000000	0.000000	0.000000	-0.281260	1.131928	0.000000
125	0.244339	0.002534	0.052538	0.266226	0.000000	0.000000	0.000000	-0.272987	1.128267	0.000000
126	0.264592	0.001371	0.052932	0.286516	0.000000	0.000000	0.000000	-0.278199	1.130574	0.000000
127	0.284799	0.000237	0.053170	0.306756	0.000000	0.000000	0.000000	-0.251332	1.121166	0.000000
128	0.304906	-0.000837	0.053191	0.326891	0.000000	0.000000	0.000000	-0.241311	1.118629	0.000000
129	0.324991	-0.001897	0.053034	0.347005	0.000000	0.000000	0.000000	-0.231760	1.114141	0.000000
130	0.344956	-0.002887	0.052751	0.366997	0.000000	0.000000	0.000000	-0.224638	1.109847	0.000000
131	0.374781	-0.004283	0.052054	0.396893	0.000000	0.000000	0.000000	-0.209570	1.106633	0.000000
132	0.404482	-0.005637	0.051129	0.426609	0.000000	0.000000	0.000000	-0.196276	1.099570	0.000000
133	0.433973	-0.006855	0.049957	0.456148	0.000000	0.000000	0.000000	-0.187360	1.089661	0.000000

Figure 26. - Continued.

POINT	XSTRM	YSTRM	ZSTRM	SSTRM	XNSTRM	YNSTRM	ZNSTRM	CPSTRM	VSTRM	BSTRM
134	0.477895	-0.008501	0.047812	0.500153	0.000000	0.000000	0.000000	-0.165876	1.079757	0.000000
135	0.521440	-0.009937	0.045299	0.543794	0.000000	0.000000	0.000000	-0.146403	1.070702	0.000000
136	0.564615	-0.011168	0.042476	0.587079	0.000000	0.000000	0.000000	-0.127509	1.061842	0.000000
137	0.607432	-0.012205	0.039393	0.630019	0.000000	0.000000	0.000000	-0.109598	1.053374	0.000000
138	0.671002	-0.014386	0.034362	0.783800	0.000000	0.000000	0.000000	-0.082107	1.040244	0.000000
139	0.764789	-0.014216	0.026056	0.979599	0.000000	0.000000	0.000000	-0.040489	1.020044	0.000000
140	0.856414	-0.012420	0.016957	0.880035	0.000000	0.000000	0.000000	0.010886	0.994542	0.000000
141	0.945047	-0.011388	0.007325	0.969206	0.000000	0.000000	0.000000	0.093247	0.952236	0.000000
142	0.969462	-0.010644	0.004569	0.993800	0.000000	0.000000	0.000000	0.180636	0.927989	0.000000
143	0.821181	-0.009634	0.003140	1.008625	0.000000	0.000000	0.000000	0.180441	0.905295	0.000000
144	0.994436	-0.009298	0.001938	1.018975	0.000000	0.000000	0.000000	0.263496	0.858198	0.000000
145	0.997858	-0.009004	0.001809	1.02416	0.000000	0.000000	0.000000	0.244327	0.869295	0.000000
146	1.00352	-0.008742	0.001754	1.029223	0.000000	0.000000	0.000000	0.216623	0.885086	0.000000
147	1.008490	-0.008502	0.001722	1.033078	0.000000	0.000000	0.000000	0.173308	0.895931	0.000000
148	1.012108	-0.008280	0.001683	1.038703	0.000000	0.000000	0.000000	0.171353	0.903959	0.000000
149	1.017579	-0.007972	0.001663	1.042183	0.000000	0.000000	0.000000	0.157669	0.910301	0.000000
150	1.025859	-0.007554	0.001642	1.045474	0.000000	0.000000	0.000000	0.142057	0.917786	0.000000
151	1.038403	-0.007000	0.001619	1.050330	0.000000	0.000000	0.000000	0.124971	0.926252	0.000000
152	1.051056	-0.006511	0.001593	1.063034	0.000000	0.000000	0.000000	0.112283	0.935430	0.000000
153	1.070184	-0.005866	0.001566	1.075692	0.000000	0.000000	0.000000	0.098003	0.942187	0.000000
154	1.093118	-0.005047	0.001568	1.093831	0.000000	0.000000	0.000000	0.082725	0.949735	0.000000
155	1.142894	-0.004050	0.001588	1.123777	0.000000	0.000000	0.000000	0.07178	0.957745	0.000000
156	1.209105	-0.002904	0.001555	1.167564	0.000000	0.000000	0.000000	0.052158	0.965827	0.000000
157	1.309191	-0.001690	0.001521	1.233786	0.000000	0.000000	0.000000	0.038286	0.973572	0.000000
158	1.460346	-0.000550	0.001511	1.333878	0.000000	0.000000	0.000000	0.026027	0.980670	0.000000
159	1.688396	0.000336	0.001504	1.485038	0.000000	0.000000	0.000000	0.015762	0.986900	0.000000
160				1.713089	0.000000	0.000000	0.000000		0.992088	0.000000
1	0.998040	-0.003394	0.000000	1.023690	0.122563	-0.070762	-0.989935	0.267199	0.856038	0.000000
2	0.995806	-0.003627	-0.000260	1.021629	0.122154	-0.070526	-0.990002	0.251837	0.864964	0.000000
3	0.992005	-0.004200	-0.001031	1.014750	0.121166	-0.069955	-0.990164	0.199384	0.894771	0.000000
4	0.978420	-0.004902	-0.002295	1.003876	0.119901	-0.069225	-0.990369	0.155148	0.919158	0.000000
5	0.935866	-0.005671	-0.004027	0.988922	0.117921	-0.068082	-0.990686	0.118772	0.938737	0.000000
6	0.944966	-0.006311	-0.006175	0.970168	0.115193	-0.066507	-0.991114	0.088515	0.954717	0.000000
7	0.922602	-0.007012	-0.008695	0.947651	0.112261	-0.064854	-0.991563	0.062126	0.968439	0.000000
8	0.896932	-0.007426	-0.011335	0.923822	0.109045	-0.062957	-0.992041	0.038004	0.980814	0.000000
9	0.867996	-0.007887	-0.014636	0.892716	0.105440	-0.060876	-0.992561	0.015945	0.991995	0.000000
10	0.836210	-0.008158	-0.017935	0.860758	0.101703	-0.058718	-0.993080	-0.004109	1.002055	0.000000
11	0.801877	-0.008232	-0.021382	0.826252	0.097737	-0.056428	-0.993611	-0.023871	1.011865	0.000000
12	0.752263	-0.008188	-0.024907	0.789469	0.093400	-0.053924	-0.994167	-0.042343	1.020952	0.000000
13	0.726785	-0.007925	-0.028449	0.750827	0.089015	-0.051393	-0.994704	-0.059483	1.029483	0.000000
14	0.686788	-0.007435	-0.031365	0.710673	0.084184	-0.048604	-0.995264	-0.078658	1.038585	0.000000
15	0.645622	-0.006751	-0.035368	0.669361	0.078955	-0.045584	-0.995835	-0.095521	1.046671	0.000000
16	0.603659	-0.005873	-0.038253	0.627263	0.073220	-0.042274	-0.996419	-0.114449	1.055675	0.000000
17	0.561268	-0.004819	-0.041647	0.58751	0.066732	-0.038528	-0.997027	-0.132066	1.063986	0.000000
18	0.518820	-0.003568	-0.044392	0.542196	0.066732	-0.035358	-0.997632	-0.151102	1.072894	0.000000
19	0.476652	-0.002161	-0.046791	0.499937	0.059559	-0.029674	-0.998237	-0.169822	1.081583	0.000000
20	0.435133	-0.000585	-0.048792	0.458339	0.051396	-0.024291	-0.998819	-0.189219	1.090513	0.000000
21	0.394577	0.001137	-0.050333	0.417117	0.031616	-0.018254	-0.999333	-0.207208	1.098730	0.000000
22	0.355263	0.002949	-0.051390	0.378347	0.019877	-0.011476	-0.999737	-0.226142	1.107313	0.000000

Figure 26. - Continued.

23	0.317468	0.004846	-0.051918	0.340501	0.006559	-0.003787	-0.999971	-0.243620	1.115177	0.000000
24	0.281455	0.006782	-0.051901	0.304637	-0.008362	0.004028	-0.999953	-0.260220	1.122595	0.000000
25	0.247421	0.008731	-0.050129	0.278342	-0.025056	0.014466	-0.999501	-0.274639	1.120999	0.000000
26	0.215539	0.010632	-0.052112	0.250383	-0.045087	0.025165	-0.998373	-0.286362	1.134179	0.000000
27	0.185941	0.012438	-0.048575	0.208686	-0.064045	0.036977	-0.997262	-0.295303	1.138114	0.000000
28	0.158763	0.014138	-0.046462	0.181372	-0.086941	0.050196	-0.994968	-0.302177	1.141130	0.000000
29	0.134058	0.015689	-0.043908	0.156488	-0.112625	0.065024	-0.991508	-0.304269	1.142046	0.000000
30	0.111872	0.017047	-0.040980	0.134068	-0.141537	0.081717	-0.986554	-0.302322	1.141193	0.000000
31	0.092190	0.018203	-0.037733	0.114006	-0.173460	0.100729	-0.979497	-0.293916	1.137504	0.000000
32	0.074987	0.019116	-0.034243	0.096509	-0.212526	0.122702	-0.969421	-0.278031	1.130500	0.000000
33	0.060187	0.019775	-0.030571	0.081266	-0.255338	0.148112	-0.955119	-0.249935	1.118005	0.000000
34	0.047673	0.020167	-0.026803	0.068172	-0.308903	0.178345	-0.934223	-0.208415	1.099279	0.000000
35	0.037307	0.020260	-0.022984	0.057124	-0.371043	0.214222	-0.903569	-0.142327	1.068797	0.000000
36	0.028910	0.020040	-0.019208	0.047915	-0.444606	0.256693	-0.858157	-0.048008	1.023722	0.000000
37	0.022259	0.019467	-0.015519	0.040287	-0.530856	0.306490	-0.790099	0.084628	0.955751	0.000000
38	0.017097	0.018475	-0.011986	0.033954	-0.624244	0.360407	-0.693128	0.251007	0.865444	0.000000
39	0.013107	0.016970	-0.008695	0.028567	-0.716152	0.413470	-0.562288	0.428305	0.756105	0.000000
40	0.009882	0.014692	-0.005716	0.023621	-0.793461	0.458105	-0.400699	0.584169	0.644849	0.000000
41	0.006826	0.010749	-0.003135	0.017893	-0.841699	0.485955	-0.235352	0.684708	0.561508	0.000000
42	0.002374	0.003956	-0.001117	0.009609	-0.861861	0.497595	-0.097951	0.724776	0.526618	0.000000
43	-0.002475	-0.004287	0.000000	0.000000	-0.866026	0.500000	0.000000	0.730279	0.519347	0.000000
44	-0.002437	-0.004308	0.001117	-0.001118	-0.861861	0.497595	0.097951	0.724773	0.524620	0.000000
45	0.002270	0.003095	0.003135	-0.010087	-0.841699	0.485955	0.235352	0.685052	0.561225	0.000000
46	0.005700	0.007448	0.005716	-0.016237	-0.793461	0.458105	0.400699	0.582904	0.645830	0.000000
47	0.009080	0.009960	0.008695	-0.021382	-0.716152	0.413470	0.562288	0.424448	0.758652	0.000000
48	0.013254	0.011819	0.011986	-0.027028	-0.624244	0.360407	0.693128	0.246191	0.868222	0.000000
49	0.018505	0.012964	0.015519	-0.033459	-0.530512	0.306291	0.790407	0.079369	0.959495	0.000000
50	0.025192	0.013601	0.019200	-0.041120	-0.444606	0.256665	0.858157	0.051561	1.025456	0.000000
51	0.033630	0.013892	0.022984	-0.050372	-0.371043	0.214249	0.903542	0.146352	1.070678	0.000000
52	0.044019	0.013838	0.026795	-0.061438	-0.308959	0.178377	0.934198	0.210497	1.100226	0.000000
53	0.056544	0.013482	0.030571	-0.074524	-0.256906	0.148324	0.954987	0.253192	1.119461	0.000000
54	0.071356	0.012844	0.034243	-0.089797	-0.212475	0.122672	0.969436	0.296811	1.131772	0.000000
55	0.088578	0.011948	0.037733	-0.107393	-0.174268	0.100613	0.979545	0.287196	1.138008	0.000000
56	0.108228	0.010822	0.040972	-0.127379	-0.141528	0.081711	0.986556	0.274795	1.141741	0.000000
57	0.130471	0.009477	0.043908	-0.149816	-0.112786	0.065117	0.991483	0.260144	1.143116	0.000000
58	0.155169	0.007932	0.046462	-0.174694	-0.086861	0.050207	0.994946	0.243538	1.142174	0.000000
59	0.182356	0.006246	0.048575	-0.202014	-0.064045	0.036977	0.997262	0.225755	1.138776	0.000000
60	0.211956	0.004444	0.050212	-0.231714	-0.043587	0.023165	0.998733	0.208088	1.134547	0.000000
61	0.243841	0.002548	0.051329	-0.263775	-0.025056	0.014466	0.999581	0.188920	1.129068	0.000000
62	0.277888	0.000620	0.051901	-0.297781	-0.008362	0.004828	0.999953	0.169798	1.122562	0.000000
63	0.313905	-0.001308	0.051918	-0.333850	0.006561	-0.003788	0.999971	0.150976	1.115140	0.000000
64	0.351696	-0.003193	0.051390	-0.371692	0.019764	-0.011411	0.999740	0.131916	1.107138	0.000000
65	0.391018	-0.005010	0.050342	-0.411069	0.031610	-0.018250	0.999334	0.109131	1.091376	0.000000
66	0.431576	-0.006727	0.048792	-0.451694	0.042181	-0.024353	0.998813	0.089200	1.090376	0.000000
67	0.473105	-0.008287	0.046791	-0.493301	0.051396	-0.029274	0.998237	0.069798	1.081572	0.000000
68	0.515274	-0.009693	0.044392	-0.535561	0.059559	-0.034386	0.997632	0.050976	1.072836	0.000000
69	0.557732	-0.010925	0.041647	-0.578125	0.066732	-0.038528	0.997027	0.033915	1.063915	0.000000
70	0.600126	-0.011975	0.038625	-0.620640	0.073290	-0.042248	0.996419	0.014248	1.055680	0.000000
71	0.642117	-0.012806	0.035368	-0.662765	0.078955	-0.045584	0.995835	0.009538	1.046605	0.000000
72	0.683290	-0.013475	0.031965	-0.704084	0.084074	-0.048540	0.995277	0.007823	1.038379	0.000000
73	0.723330	-0.013891	0.028458	-0.744280	0.089020	-0.051396	0.994703	0.006094	1.029803	0.000000
74	0.761736	-0.014279	0.024907	-0.782851	0.093514	-0.053390	0.994153	0.004207	1.020797	0.000000
75	0.798394	-0.014248	0.021382	-0.819361	0.097733	-0.056428	0.993617	0.002370	1.011815	0.000000
76	0.832724	-0.014179	0.017935	-0.854180	0.101703	-0.058178	0.993080	0.001403	1.002048	0.000000
77	0.864479	-0.013962	0.014636	-0.886108	0.105440	-0.060876	0.992561	0.015960	0.991908	0.000000

Figure 26. - Continued.

78	0.893488	-0.013374	0.011535	-0.915288	0.109024	-0.062945	0.992044	0.037997	0.980817	0.000000
79	0.919233	-0.012847	0.008695	-0.941194	0.112265	-0.064816	0.991562	0.061947	0.968531	0.000000
80	0.941448	-0.012387	0.006175	-0.963557	0.115187	-0.066503	0.991115	0.088480	0.954735	0.000000
81	0.960124	-0.011666	0.004027	-0.982370	0.117890	-0.068064	0.990691	0.118574	0.938843	0.000000
82	0.974933	-0.010942	0.002295	-0.997297	0.119901	-0.069225	0.990369	0.154911	0.919287	0.000000
83	0.985735	-0.010211	0.001031	-1.008197	0.121166	-0.069955	0.990164	0.199147	0.894904	0.000000
84	0.992325	-0.009657	0.000260	-1.014855	0.122154	-0.070526	0.990002	0.251578	0.865114	0.000000
85	0.994487	-0.009549	0.000000	-1.017035	0.061436	-0.073570	0.997481	0.263700	0.858079	0.000000
86	1.002866	-0.008892	0.000000	-1.025440	0.000000	0.000000	1.000000	0.207076	0.890463	0.000000
87	1.015324	-0.008099	0.000000	-1.037923	0.000000	0.000000	1.000000	0.162773	0.915001	0.000000
88	1.046131	-0.006701	0.000000	-1.068762	0.000000	0.000000	1.000000	0.116800	0.939787	0.000000

*** SUBROUTINE STREM3D COMPLETE ***

CPU TIME = 100.791

TRAJECTORY DATA ARE WRITTEN ON UNIT 10 FOR PLOTTING

WATER DROP DIAMETER = 2.00000E+01 MICROMETERS
 PARTICLE SETTLING SPEED = 1.93333E-04 M/SEC

*** SUBROUTINE CONFAC BEGINS ***

*** SUBROUTINE CONFAC RUNS COMPLETE, CPU TIME = 140.459 SECONDS ***

***** OUTPUT FROM SUBROUTINE CONFAC FOR ICEC= 1

XSCI	YSCI	ZSCI	XSCF	YSCF	ZSCF
-20.00000	-0.01042	0.06176	0.00000	0.00002	0.07013
-20.00000	-0.01143	-0.04314	0.00000	0.00003	-0.05034

*** SUBROUTINE IMPLIM BEGINS ***

*** SUBROUTINE IMPLIM RUNS COMPLETE, CPU TIME = 369.512 SECONDS ***

***** OUTPUT FROM SUBROUTINE IMPLIM FOR ICEC= 1

Figure 26. - Continued.

XTIP	YTIP	ZTIP	XTIF	YTIF	ZTIF
-20.00000	-0.01086	0.01623	0.05242	0.00700	0.03046
-20.00000	-0.01117	-0.01615	0.05237	0.00669	-0.03049

SUBROUTINE ARYTRJ INPUT FOR SLICE: 1

ROW (NBRC)	COLUMN (NBCC)	X(NBRC,NBCC)	Y(NBRC,NBCC)	Z(NBRC,NBCC)
1	1	-20.000000	-0.010858	0.016225
2	1	-20.000000	-0.010875	0.014522
3	1	-20.000000	-0.010891	0.012818
4	1	-20.000000	-0.010908	0.011114
5	1	-20.000000	-0.010924	0.009410
6	1	-20.000000	-0.010940	0.007706
7	1	-20.000000	-0.010957	0.006003
8	1	-20.000000	-0.010973	0.004299
9	1	-20.000000	-0.010990	0.002595
10	1	-20.000000	-0.011006	0.000891
11	1	-20.000000	-0.011023	-0.000813
12	1	-20.000000	-0.011039	-0.002517
13	1	-20.000000	-0.011055	-0.004220
14	1	-20.000000	-0.011072	-0.005924
15	1	-20.000000	-0.011088	-0.007628
16	1	-20.000000	-0.011105	-0.009332
17	1	-20.000000	-0.011121	-0.011036
18	1	-20.000000	-0.011137	-0.012739
19	1	-20.000000	-0.011154	-0.014443
20	1	-20.000000	-0.011170	-0.016147

*** SUBROUTINE ARYTRJ BEGINS ***

*** SUBROUTINE ARYTRJ RUNS COMPLETE, CPU TIME = 548.081 SECONDS ***

***** OUTPUT FROM SUBROUTINE ARYTRJ FOR ICEC= 1

XBLI	YBLI	ZBLI	XBLF	YBLF	ZBLF	TNORMX	TNORMY	TNORMZ
-20.00000	-0.01086	0.01623	0.05242	0.00700	0.03046	-0.96770	-0.05566	-0.24588
-20.00000	-0.01087	0.01452	0.02851	0.00552	0.02286	-0.96948	-0.09531	-0.22591
-20.00000	-0.01089	0.01282	0.01989	0.00488	0.01904	-0.97162	-0.11519	-0.20658
-20.00000	-0.01091	0.01111	0.01428	0.00444	0.01592	-0.97379	-0.13088	-0.18604
-20.00000	-0.01092	0.00941	0.01031	0.00410	0.01315	-0.97602	-0.14387	-0.16338
-20.00000	-0.01094	0.00771	0.00729	0.00383	0.01056	-0.97820	-0.15551	-0.13766
-20.00000	-0.01096	0.00600	0.00501	0.00361	0.00809	-0.98025	-0.16514	-0.10883
-20.00000	-0.01097	0.00430	0.00339	0.00345	0.00572	-0.98206	-0.17159	-0.07822

Figure 26. - Continued.

```

-20.00000 -0.01099 0.00259 0.00246 0.00335 0.00341 -0.90335 -0.17550 -0.04726
-20.00000 -0.01101 0.00089 0.00195 0.00328 0.00113 0.98400 -0.17750 -0.01554
-20.00000 -0.01102 -0.00081 0.00194 0.00327 -0.00113 -0.98400 -0.17749 0.01554
-20.00000 -0.01104 -0.00252 0.00243 0.00330 -0.00341 -0.90334 -0.17553 0.04726
-20.00000 -0.01106 -0.00422 0.00494 0.00336 -0.00572 -0.98206 -0.17159 0.07820
-20.00000 -0.01107 -0.00592 0.00494 0.00350 -0.00809 -0.98024 -0.16516 0.10885
-20.00000 -0.01109 -0.00763 0.00720 0.00368 -0.01056 -0.97819 -0.15555 0.13769
-20.00000 -0.01110 -0.00933 0.01021 0.00392 -0.01315 -0.97601 -0.14389 0.16339
-20.00000 -0.01112 -0.01104 0.01415 0.00422 -0.01592 -0.97378 -0.13090 0.18603
-20.00000 -0.01114 -0.01274 0.01972 0.00463 0.01904 -0.97159 -0.11526 0.20670
-20.00000 -0.01115 -0.01444 0.02836 0.00523 -0.02286 -0.96948 -0.09526 0.22593
-20.00000 -0.01117 -0.01615 0.05237 0.00669 -0.03049 -0.96776 -0.05537 0.24570

```

SUBROUTINE BETAC OUTPUT FOR SLICE: 1

ROW (NIL)	COLUMN (NJL)	X(NBRC,NBCC)	Y(NBRC,NBCC)	Z(NBRC,NBCC)	BETA(NBRC,NBCC)	B(NORMX)	B(NORMY)	B(NORMZ)
1	1	0.04047	0.00626	0.02666	0.06909	-0.96883	-0.07548	-0.23590
2	1	0.02420	0.00520	0.02095	0.18209	-0.97064	-0.10525	-0.21625
3	1	0.01708	0.00466	0.01748	0.26396	-0.97279	-0.12303	-0.19631
4	1	0.01629	0.00427	0.01454	0.34422	-0.97498	-0.13738	-0.17471
5	1	0.00880	0.00397	0.01185	0.41097	-0.97720	-0.14969	-0.15052
6	1	0.00615	0.00372	0.00932	0.47722	-0.97933	-0.16033	-0.12325
7	1	0.00420	0.00353	0.00690	0.54371	-0.98127	-0.16837	-0.09353
8	1	0.00292	0.00340	0.00456	0.60777	-0.98282	-0.17354	-0.06274
9	1	0.00220	0.00332	0.00227	0.63748	-0.98380	-0.17650	-0.03140
10	1	0.00194	0.00328	0.00000	0.65128	-0.98412	-0.17750	0.00000
11	1	0.00218	0.00328	-0.00227	0.63749	-0.98379	-0.17651	0.03140
12	1	0.00289	0.00333	0.00456	0.60782	-0.98282	-0.17356	0.06273
13	1	0.00414	0.00343	0.00690	0.54368	-0.98127	-0.16838	0.09353
14	1	0.00607	0.00359	0.00932	0.47723	-0.97933	-0.16035	0.12327
15	1	0.00870	0.00380	0.01185	0.41099	-0.97720	-0.14972	0.15054
16	1	0.01218	0.00407	0.01454	0.34433	-0.97498	-0.13739	0.17471
17	1	0.01694	0.00443	0.01748	0.26466	-0.97277	-0.12300	0.19637
18	1	0.02404	0.00493	0.02095	0.18160	-0.97063	-0.10526	0.21631
19	1	0.04036	0.00596	0.02668	0.06871	-0.96886	-0.07532	0.23581

*** SUBROUTINE BETAC COMPLETE ***

CPU TIME = 548.166

SUBROUTINE BSTREM OUTPUT FOR SLICE: 1

POINT	XSTRM	YSTRM	ZSTRM	SSTRM	XNSTRM	YNSTRM	ZNSTRM	CFSTRM	VSTRM	BSTRM
1	0.99804	-0.00339	0.00000	1.02369	0.12256	-0.07076	-0.98993	0.26720	0.85604	0.00000
2	0.99581	-0.00363	-0.00026	1.02143	0.12215	-0.07053	-0.99000	0.25184	0.86496	0.00000
3	0.98921	-0.00420	-0.00103	1.01476	0.12117	-0.06996	-0.99016	0.19938	0.89477	0.00000
4	0.97842	-0.00490	-0.00230	1.00388	0.11990	-0.06922	-0.99037	0.15515	0.91916	0.00000

Figure 26. - Continued.

5	0.96359	-0.00567	0.98092	0.11792	-0.06008	-0.99069	0.11077	0.93874	0.00000
6	0.94497	-0.00631	0.97017	0.11519	-0.06651	-0.99111	0.08851	0.95472	0.00000
7	0.92260	-0.00701	0.94765	0.11226	-0.06481	-0.99156	0.06213	0.96844	0.00000
8	0.89693	-0.01154	0.92182	0.10905	-0.06296	-0.99204	0.03800	0.98001	0.00000
9	0.86800	-0.00789	0.89272	0.10544	-0.06088	-0.99256	0.01595	0.99200	0.00000
10	0.83621	-0.00816	0.86076	0.10170	-0.05872	-0.99308	-0.00441	1.00205	0.00000
11	0.80188	-0.02138	0.82625	0.09774	-0.05643	-0.99361	0.02307	1.01107	0.00000
12	0.76526	-0.02491	0.78947	0.09302	-0.05392	-0.99417	-0.04234	1.02095	0.00000
13	0.72678	-0.02945	0.75083	0.08900	-0.05139	-0.99470	-0.06204	1.02940	0.00000
14	0.68679	-0.03197	0.71067	0.08418	-0.04860	-0.99526	-0.07866	1.03850	0.00000
15	0.64562	-0.00675	0.66936	0.07895	-0.04558	-0.99584	-0.09558	1.04667	0.00000
16	0.60366	-0.00587	0.62726	0.07322	-0.04227	-0.99642	-0.11445	1.05567	0.00000
17	0.56127	-0.00402	0.58475	0.06675	-0.03833	-0.99703	-0.13207	1.06399	0.00000
18	0.51882	-0.00357	0.54220	0.05956	-0.03439	-0.99763	-0.15110	1.07289	0.00000
19	0.47665	-0.00216	0.49994	0.05140	-0.02917	-0.99824	-0.16982	1.08158	0.00000
20	0.43513	-0.00050	0.45834	0.04207	-0.02429	-0.99882	-0.18922	1.09051	0.00000
21	0.39458	-0.00114	0.41772	0.03162	-0.01825	-0.99933	-0.20721	1.09873	0.00000
22	0.35526	-0.00295	0.37835	0.01988	-0.01148	-0.99974	-0.22614	1.10731	0.00000
23	0.31747	0.00485	0.34050	0.00656	-0.00379	-0.99997	-0.24562	1.11518	0.00000
24	0.28146	0.00678	0.30444	-0.00836	0.00483	-0.99995	-0.26022	1.12260	0.00000
25	0.24742	0.00873	0.27034	-0.02506	0.01447	-0.99958	-0.27464	1.12900	0.00000
26	0.21554	0.01063	0.23838	-0.04359	0.02517	-0.99873	-0.28636	1.13418	0.00000
27	0.18594	0.01244	0.20869	-0.06405	0.03698	-0.99726	-0.29530	1.13811	0.00000
28	0.15876	0.01414	0.18137	-0.08694	0.05020	-0.99595	-0.30218	1.14113	0.00000
29	0.13406	0.01569	0.15649	-0.11262	0.06502	-0.99451	-0.30927	1.14205	0.00000
30	0.11187	0.01705	0.13407	-0.14154	0.08112	-0.99355	-0.31419	1.14119	0.00000
31	0.09219	0.01820	0.11409	-0.17447	0.10073	-0.99250	-0.31792	1.13750	0.00000
32	0.07499	0.01912	0.09651	-0.21253	0.12270	-0.99130	-0.32032	1.13050	0.00000
33	0.06019	0.01977	0.08125	-0.25654	0.14811	-0.98994	-0.32189	1.11801	0.00000
34	0.04767	0.02017	0.06817	-0.30890	0.17835	-0.98822	-0.32041	1.10928	0.00000
35	0.03731	0.02026	0.05712	-0.37104	0.21422	-0.98655	-0.31433	1.10680	0.00000
36	0.02891	0.02004	0.04791	-0.44461	0.25669	-0.98516	-0.30480	1.02372	0.22723
37	0.02226	0.01947	0.04029	-0.53086	0.30649	-0.98401	-0.29463	0.95675	0.32142
38	0.01710	0.01848	0.03395	-0.62424	0.36041	-0.98313	-0.28101	0.86544	0.40987
39	0.01311	0.01697	0.02857	-0.71615	0.41347	-0.98229	-0.26841	0.75611	0.49679
40	0.00988	0.01469	0.02362	-0.79346	0.45810	-0.98170	-0.25817	0.64485	0.57758
41	0.00663	0.01075	0.01789	-0.84170	0.48595	-0.98151	-0.25355	0.56151	0.62665
42	0.00396	0.00396	0.00961	-0.86186	0.49760	-0.98000	-0.24780	0.52462	0.64455
43	-0.00248	-0.00429	0.00000	-0.86603	0.50000	0.00000	-0.24028	0.51935	0.65130
44	-0.00244	-0.00431	0.00112	-0.86186	0.49760	0.09795	-0.23777	0.52462	0.64455
45	0.00221	0.00309	0.00314	-0.84170	0.48595	0.23535	-0.23503	0.56123	0.62662
46	0.00570	0.00745	0.00572	-0.79346	0.45810	0.40070	-0.23355	0.64485	0.57758
47	0.00906	0.00996	0.00870	-0.71615	0.41347	0.56229	-0.23355	0.52462	0.64455
48	0.01325	0.01182	0.01199	-0.62424	0.36041	0.69313	-0.24619	0.75862	0.49680
49	0.01850	0.01296	0.01552	-0.53051	0.30629	0.79091	-0.24937	0.86822	0.41027
50	0.02519	0.01360	0.01920	-0.44456	0.25666	0.85819	-0.24937	0.95950	0.32121
51	0.03363	0.01389	0.02298	-0.37109	0.21425	0.90354	-0.05156	1.02546	0.22721
52	0.04402	0.02680	0.03086	-0.30896	0.17838	0.93429	-0.14635	1.07068	0.14898
53	0.05654	0.03057	0.03752	-0.25691	0.14832	0.95499	-0.21050	1.10023	0.07372
54	0.07136	0.03424	0.04324	-0.21247	0.12267	0.96944	-0.25319	1.11946	0.00000
55	0.08858	0.03773	0.04739	-0.17427	0.10061	0.97954	-0.28091	1.13177	0.00000
56	0.10827	0.04097	0.05037	-0.14153	0.08171	0.98656	-0.29643	1.13861	0.00000
57	0.13047	0.04391	0.05298	-0.11279	0.06512	0.99148	-0.30357	1.14174	0.00000
58	0.15517	0.04646	0.05469	-0.08696	0.05021	0.99495	-0.30671	1.14312	0.00000
59	0.18236	0.04858	0.05701	-0.06405	0.03698	0.99726	-0.30956	1.14217	0.00000

Figure 26. - Continued.

POINT	XSTRM	YSTRM	ZSTRM	SSTRM	XNSTRM	YNSTRM	ZNSTRM	CPSTRM	VSTRM	BSTRM
60	0.21196	0.00444	0.05021	-0.23171	-0.04359	0.02517	0.99873	-0.28720	1.13455	0.00000
61	0.24384	0.00255	0.05133	-0.26368	-0.02506	0.01467	0.99958	-0.27479	1.12907	0.00000
62	0.27789	0.00062	0.05190	-0.29778	-0.00836	0.00483	0.99995	-0.26014	1.12256	0.00000
63	0.31390	-0.00131	0.05192	-0.33505	-0.00656	-0.00379	0.99997	-0.24354	1.11514	0.00000
64	0.35170	-0.00319	0.05139	-0.37169	-0.01976	-0.01141	0.99974	-0.22576	1.10714	0.00000
65	0.39102	-0.00501	0.05034	-0.41107	-0.03161	-0.01825	0.99933	-0.20809	1.09913	0.00000
66	0.43158	-0.00673	0.04879	-0.45169	-0.04218	-0.02435	0.99881	-0.18892	1.09038	0.00000
67	0.47311	-0.00829	0.04679	-0.49330	-0.05140	-0.02967	0.99824	-0.16900	1.08157	0.00000
68	0.51527	-0.00969	0.04439	-0.53556	-0.05956	-0.03439	0.99763	-0.15090	1.07284	0.00000
69	0.55773	-0.01093	0.04165	-0.57813	-0.06673	-0.03853	0.99703	-0.13192	1.06392	0.00000
70	0.60013	-0.01198	0.03863	-0.62064	-0.07322	-0.04227	0.99642	-0.11425	1.05558	0.00000
71	0.64212	-0.01281	0.03537	-0.66276	-0.07895	-0.04558	0.99584	-0.09538	1.04661	0.00000
72	0.68329	-0.01348	0.03197	-0.70408	-0.08407	-0.04854	0.99528	-0.07823	1.03830	0.00000
73	0.72333	-0.01389	0.02846	-0.74528	-0.08902	-0.05140	0.99470	-0.06049	1.02980	0.00000
74	0.76174	-0.01428	0.02491	-0.78285	-0.09351	-0.05399	0.99415	-0.04203	1.02080	0.00000
75	0.79839	-0.01425	0.02138	-0.81968	-0.09774	-0.05643	0.99361	-0.02377	1.01182	0.00000
76	0.83272	-0.01418	0.01794	-0.85418	-0.10170	-0.05872	0.99308	-0.00410	1.00205	0.00000
77	0.86548	-0.01396	0.01464	-0.88611	-0.10544	-0.06088	0.99256	0.01596	0.99199	0.00000
78	0.89349	-0.01337	0.01154	-0.91529	-0.10902	-0.06294	0.99204	0.03800	0.98082	0.00000
79	0.91923	-0.01285	0.00870	-0.94119	-0.11227	-0.06482	0.99156	0.06195	0.96853	0.00000
80	0.94145	-0.01239	0.00618	-0.96356	-0.11519	-0.06650	0.99112	0.08848	0.95474	0.00000
81	0.96012	-0.01167	0.00403	-0.98237	-0.11789	-0.06806	0.99069	0.11857	0.93884	0.00000
82	0.97493	-0.01094	0.00230	-0.99730	-0.11990	-0.06922	0.99037	0.15491	0.91929	0.00000
83	0.98573	-0.01021	0.00103	-1.00820	-0.12117	-0.06996	0.99016	0.19915	0.89490	0.00000
84	0.99232	-0.00966	0.00026	-1.01485	-0.12183	-0.07053	0.99000	0.25158	0.86511	0.00000
85	0.99449	-0.00955	0.00000	-1.01704	-0.12144	-0.07144	0.99000	0.26370	0.85808	0.00000
86	1.00287	-0.00889	0.00000	-1.02544	-0.00000	0.00000	1.00000	0.20708	0.85046	0.00000
87	1.01532	-0.00810	0.00000	-1.03792	0.00000	0.00000	1.00000	0.16277	0.91500	0.00000
88	1.04613	-0.00670	0.00000	-1.06876	0.00000	0.00000	1.00000	0.11680	0.93979	0.00000

*** SUBROUTINE BSTRM COMPLETE ***

CPU TIME = 548.273

SUBROUTINE STREM3D OUTPUT FOR SLICE: 2

Figure 26. - Continued.

14	1.286912	0.539619	0.989705	0.084864	-0.995264	0.146291	0.925046	0.000000
15	1.227517	0.539190	0.931942	0.078955	-0.995035	0.068194	0.965301	0.000000
16	1.168388	0.539734	0.872469	0.073220	-0.996419	0.027959	0.985921	0.000000
17	1.108179	0.540819	0.811944	0.066732	-0.997027	-0.038528	1.000879	0.000000
18	0.993384	0.543717	0.696637	0.059559	-0.997632	-0.046944	1.023203	0.000000
19	0.876025	0.547276	0.578085	0.051396	-0.998237	-0.092964	1.045196	0.000000
20	0.796241	0.549899	0.498916	0.043273	-0.998819	-0.125781	1.061028	0.000000
21	0.742391	0.551675	0.444978	0.031616	-0.999333	-0.147315	1.071120	0.000000
22	0.706151	0.552876	0.408695	0.019877	-0.999737	-0.165532	1.079598	0.000000
23	0.681030	0.553670	0.384360	0.004559	-0.999971	-0.177002	1.086897	0.000000
24	0.657363	0.554501	0.359868	0.000362	-0.999953	-0.187572	1.097758	0.000000
25	0.632775	0.555314	0.335265	0.025056	-0.999581	-0.194666	1.098042	0.000000
26	0.608056	0.556124	0.310333	0.045387	-0.998733	-0.215406	1.102455	0.000000
27	0.583172	0.556952	0.285633	0.064045	-0.997262	-0.237340	1.107854	0.000000
28	0.566522	0.557495	0.268972	0.084941	-0.994948	-0.243057	1.114924	0.000000
29	0.549803	0.558043	0.252236	0.112825	-0.991508	-0.245972	1.116231	0.000000
30	0.533034	0.558587	0.235447	0.141537	-0.986554	-0.261988	1.123383	0.000000
31	0.516291	0.559131	0.218592	0.174468	-0.979491	-0.264508	1.124503	0.000000
32	0.499325	0.559680	0.201669	0.212526	-0.969421	-0.279737	1.131254	0.000000
33	0.482412	0.560218	0.184771	0.256538	-0.955119	-0.284481	1.133369	0.000000
34	0.465442	0.560768	0.167655	0.308903	-0.934223	-0.291085	1.136259	0.000000
35	0.448469	0.561302	0.150580	0.371043	-0.903569	-0.302767	1.141388	0.000000
36	0.43157	0.561849	0.139175	0.444606	-0.858157	-0.299650	1.140022	0.000000
37	0.425873	0.561995	0.127151	0.530856	-0.790099	-0.307279	1.143363	0.000000
38	0.414568	0.562317	0.116334	0.624244	-0.693128	-0.301865	1.140933	0.000000
39	0.403311	0.562629	0.109905	0.716152	-0.562288	-0.302664	1.141333	0.000000
40	0.392141	0.562894	0.103351	0.793461	-0.400699	-0.300794	1.140523	0.000000
41	0.381073	0.563104	0.082157	0.841699	-0.235352	-0.279933	1.131351	0.000000
42	0.370144	0.563239	0.033845	0.861861	-0.495955	-0.261177	1.123021	0.000000
43	0.359463	0.563239	0.070865	0.866026	-0.500000	-0.222687	1.105752	0.000000
44	0.349191	0.563011	0.048755	0.861861	-0.497595	-0.158201	1.076198	0.000000
45	0.339572	0.562415	0.038199	0.841699	-0.485955	-0.046798	1.023131	0.000000
46	0.331077	0.561181	0.028393	0.793461	-0.458105	0.135458	0.929808	0.000000
47	0.322622	0.559016	0.019848	0.716152	-0.413470	0.388524	0.781949	0.000000
48	0.318723	0.556068	0.012701	0.624244	-0.369407	0.562560	0.661392	0.000000
49	0.313613	0.552913	0.006339	0.530512	-0.306291	0.607226	0.626717	0.000000
50	0.308100	0.550000	0.000000	0.444557	-0.256665	0.580545	0.647653	0.000000
51	0.308100	0.550000	0.000000	0.214249	-0.142428	0.529258	0.638296	0.000000
52	0.313471	0.552394	0.002051	0.371043	-0.078377	0.636604	0.602823	0.000000
53	0.318212	0.556363	0.012146	0.308959	-0.308959	0.640821	0.599355	0.000000
54	0.322810	0.559826	0.018387	0.256996	-0.148324	0.556087	0.666268	0.000000
55	0.328238	0.562821	0.025717	0.174228	-0.122672	0.529828	0.818640	0.000000
56	0.335439	0.564804	0.034637	0.081711	-0.100613	0.486477	0.955784	0.000000
57	0.340024	0.565465	0.039942	0.065117	-0.081711	0.408144	1.020203	0.000000
58	0.344925	0.565906	0.045458	-0.086961	-0.050207	-0.113862	1.055396	0.000000
59	0.350143	0.566188	0.051168	-0.064045	0.036977	-0.153978	1.074234	0.000000
60	0.355563	0.566356	0.056989	-0.043587	0.025165	-0.209413	1.099733	0.000000
61	0.361118	0.566480	0.062888	-0.025056	0.014466	-0.223453	1.110698	0.000000
62	0.364132	0.566474	0.066064	-0.008362	0.004828	-0.248483	1.117355	0.000000
63	0.367194	0.566472	0.069266	0.006561	-0.003388	-0.257137	1.121221	0.000000
64	0.370268	0.566464	0.072473	0.019164	-0.014411	-0.266023	1.122507	0.000000
65	0.373357	0.566449	0.075689	0.031616	-0.018250	-0.266002	1.125167	0.000000
66	0.376463	0.566424	0.078913	0.042181	-0.023433	-0.281017	1.131820	0.000000
67	0.379604	0.566379	0.082154	0.051396	-0.029637	-0.287432	1.134651	0.000000
68	0.384327	0.566306	0.087018	0.059559	-0.034386	-0.286114	1.134070	0.000000

Figure 26. - Continued.

69	0.391450	0.566176	0.034934	0.094333	0.066732	-0.030528	0.997027	-0.301435	1.140805	0.000000
70	0.398641	0.566009	0.036414	0.101677	0.073220	-0.042274	0.996419	-0.299269	1.139855	0.000000
71	0.409466	0.565739	0.038683	0.112700	0.078955	-0.045584	0.995835	-0.310920	1.144954	0.000000
72	0.420346	0.565439	0.040277	0.123731	0.084074	-0.048540	0.995257	-0.303404	1.141667	0.000000
73	0.436723	0.564956	0.042633	0.140284	0.089020	-0.051396	0.994703	-0.302689	1.141354	0.000000
74	0.453112	0.564459	0.044662	0.156806	0.093514	-0.053990	0.994153	-0.305253	1.142477	0.000000
75	0.469499	0.563951	0.046338	0.173286	0.097737	-0.056428	0.993611	-0.292692	1.136966	0.000000
76	0.485889	0.563424	0.047721	0.189743	0.101703	-0.058718	0.993080	-0.283415	1.132879	0.000000
77	0.502272	0.562912	0.049228	0.206119	0.105640	-0.060876	0.992561	-0.279312	1.131067	0.000000
78	0.526619	0.562400	0.050324	0.231578	0.109024	-0.062945	0.992044	-0.262442	1.123585	0.000000
79	0.550935	0.561853	0.051278	0.254925	0.112265	-0.064816	0.991562	-0.246116	1.116295	0.000000
80	0.575130	0.561264	0.051978	0.276143	0.115187	-0.066503	0.991115	-0.234477	1.111070	0.000000
81	0.599171	0.559788	0.052346	0.302000	0.117890	-0.068064	0.990691	-0.224925	1.106763	0.000000
82	0.606034	0.559559	0.052383	0.310067	0.119901	-0.069225	0.990369	-0.219828	1.104458	0.000000
83	0.612878	0.559336	0.052399	0.316914	0.121166	-0.069955	0.990164	-0.212240	1.101018	0.000000
84	0.623114	0.559005	0.052404	0.321155	0.122154	-0.070526	0.990002	-0.206213	1.098277	0.000000
85	0.633335	0.558670	0.052388	0.327382	0.061436	-0.035470	0.997481	-0.205892	1.098131	0.000000
86	0.643544	0.558327	0.052295	0.347598	0.000000	0.000000	1.000000	-0.198268	1.094654	0.000000
87	0.653715	0.557994	0.052167	0.357774	0.000000	0.000000	1.000000	-0.189710	1.090738	0.000000
88	0.668925	0.557496	0.051943	0.372994	0.000000	0.000000	1.000000	-0.184975	1.088565	0.000000
89	0.691666	0.556736	0.051419	0.395754	0.000000	0.000000	1.000000	-0.170743	1.082009	0.000000
90	0.714283	0.555985	0.050791	0.418392	0.000000	0.000000	1.000000	-0.164511	1.079125	0.000000
91	0.748001	0.554864	0.049558	0.452151	0.000000	0.000000	1.000000	-0.146203	1.070608	0.000000
92	0.781483	0.553752	0.048028	0.485686	0.000000	0.000000	1.000000	-0.129456	1.062759	0.000000
93	0.814748	0.552647	0.046218	0.519019	0.000000	0.000000	1.000000	-0.115196	1.056028	0.000000
94	0.847789	0.551563	0.044283	0.551134	0.000000	0.000000	1.000000	-0.102843	1.050163	0.000000
95	0.880612	0.550505	0.042151	0.585044	0.000000	0.000000	1.000000	-0.091109	1.044561	0.000000
96	0.929474	0.548965	0.038652	0.634055	0.000000	0.000000	1.000000	-0.071928	1.035340	0.000000
97	1.001971	0.546788	0.032761	0.704823	0.000000	0.000000	1.000000	-0.045218	1.022359	0.000000
98	1.073488	0.544867	0.026406	0.778648	0.000000	0.000000	1.000000	-0.016751	1.008341	0.000000
99	1.178706	0.542778	0.015875	0.884613	0.000000	0.000000	1.000000	0.000000	0.983650	0.000000
100	1.233657	0.542311	0.009809	0.936990	0.000000	0.000000	1.000000	0.000000	0.963420	0.000000
101	1.287030	0.542735	0.003754	0.993417	0.000000	0.000000	1.000000	0.000000	0.924536	0.000000
102	1.301737	0.543181	0.002024	1.008231	0.000000	0.000000	1.000000	0.000000	0.898872	0.000000
103	1.309372	0.543553	0.001142	1.015926	0.000000	0.000000	1.000000	0.000000	0.871086	0.000000
104	1.313371	0.543800	0.000726	1.019955	0.000000	0.000000	1.000000	0.000000	0.866534	0.000000
105	1.315511	0.543932	0.000634	1.022100	0.000000	0.000000	1.000000	0.000000	0.864094	0.000000
106	1.317651	0.544063	0.000610	1.024245	0.000000	0.000000	1.000000	0.000000	0.864771	0.000000
107	1.319802	0.544189	0.000597	1.026399	0.000000	0.000000	1.000000	0.000000	0.873647	0.000000
108	1.321979	0.544300	0.000568	1.028579	0.000000	0.000000	1.000000	0.000000	0.882733	0.000000
109	1.324176	0.544399	0.000522	1.030779	0.000000	0.000000	1.000000	0.000000	0.889829	0.000000
110	1.327501	0.544530	0.000575	1.034107	0.000000	0.000000	1.000000	0.000000	0.898170	0.000000
111	1.330855	0.544646	0.000569	1.037462	0.000000	0.000000	1.000000	0.000000	0.904781	0.000000
112	1.335927	0.544796	0.000563	1.042537	0.000000	0.000000	1.000000	0.000000	0.912680	0.000000
113	1.343608	0.544981	0.000556	1.050219	0.000000	0.000000	1.000000	0.000000	0.921759	0.000000
114	1.352251	0.545192	0.000549	1.061865	0.000000	0.000000	1.000000	0.000000	0.931842	0.000000
115	1.362916	0.545406	0.000542	1.075931	0.000000	0.000000	1.000000	0.000000	0.942705	0.000000
116	1.399731	0.545576	0.000536	1.106346	0.000000	0.000000	1.000000	0.000000	0.954066	0.000000
117	1.426816	0.545635	0.000532	1.135432	0.000000	0.000000	1.000000	0.000000	0.962188	0.000000
118	1.454102	0.545630	0.000530	1.160717	0.000000	0.000000	1.000000	0.000000	0.968320	0.000000
119	1.495305	0.545557	0.000527	1.201921	0.000000	0.000000	1.000000	0.000000	0.975068	0.000000
120	1.557542	0.545391	0.000525	1.264157	0.000000	0.000000	1.000000	0.000000	0.981740	0.000000

SUBROUTINE STREM3D OUTPUT FOR SLICE: 2

Figure 26. - Continued.

POINT	XSTRM	YSTRM	ZSTRM	SSTRM	XNSTRM	YNSTRM	ZNSTRM	XNSTRM	YNSTRM	ZNSTRM	CPSTRM	VSTRM	BSTRM
1	1.312290	0.540905	0.000000	1.015452	0.122563	-0.070762	-0.989935	0.122563	-0.070762	-0.989935	0.252128	0.864796	0.000000
2	1.310106	0.540758	-0.000260	1.013547	0.122154	-0.070526	-0.990002	0.122154	-0.070526	-0.990002	0.249778	0.866154	0.000000
3	1.303630	0.540402	-0.001031	1.006716	0.121169	-0.069957	-0.990164	0.121169	-0.069957	-0.990164	0.210367	0.808613	0.000000
4	1.293022	0.540007	-0.002295	0.996026	0.119904	-0.069227	-0.990369	0.119904	-0.069227	-0.990369	0.166643	0.912994	0.000000
5	1.278453	0.539697	-0.004027	0.981351	0.117921	-0.068082	-0.990606	0.117921	-0.068082	-0.990606	0.131169	0.932111	0.000000
6	1.260120	0.539552	-0.006175	0.962802	0.115192	-0.066506	-0.991114	0.115192	-0.066506	-0.991114	0.102366	0.947436	0.000000
7	1.238061	0.539382	-0.008695	0.940689	0.112661	-0.064813	-0.991563	0.112661	-0.064813	-0.991563	0.077861	0.960281	0.000000
8	1.212660	0.539431	-0.011535	0.915129	0.109045	-0.062957	-0.992041	0.109045	-0.062957	-0.992041	0.056077	0.971557	0.000000
9	1.184138	0.539688	-0.014636	0.886438	0.105439	-0.060875	-0.992561	0.105439	-0.060875	-0.992561	0.036628	0.981515	0.000000
10	1.152751	0.540100	-0.017935	0.854075	0.101703	-0.058718	-0.993080	0.101703	-0.058718	-0.993080	0.019250	0.990333	0.000000
11	1.118911	0.540715	-0.021382	0.820755	0.097373	-0.056429	-0.993611	0.097373	-0.056429	-0.993611	0.002345	0.998777	0.000000
12	1.082668	0.541540	-0.024907	0.784411	0.093400	-0.053925	-0.994167	0.093400	-0.053925	-0.994167	-0.013150	1.006554	0.000000
13	1.044369	0.542494	-0.028449	0.746156	0.089015	-0.051392	-0.994704	0.089015	-0.051392	-0.994704	-0.027397	1.013872	0.000000
14	1.004868	0.543498	-0.031965	0.706287	0.084184	-0.048603	-0.995264	0.084184	-0.048603	-0.995264	-0.043802	1.021666	0.000000
15	0.963285	0.544669	-0.035368	0.665346	0.079555	-0.045585	-0.995835	0.079555	-0.045585	-0.995835	-0.058395	1.028783	0.000000
16	0.922241	0.545927	-0.038625	0.623357	0.073220	-0.042274	-0.996419	0.073220	-0.042274	-0.996419	-0.074828	1.036739	0.000000
17	0.879982	0.547211	-0.041647	0.580970	0.066732	-0.038528	-0.997027	0.066732	-0.038528	-0.997027	-0.090720	1.044376	0.000000
18	0.837605	0.548583	-0.044392	0.538482	0.059559	-0.034386	-0.997632	0.059559	-0.034386	-0.997632	-0.108197	1.052709	0.000000
19	0.795624	0.549968	-0.046791	0.496210	0.051396	-0.029674	-0.998237	0.051396	-0.029674	-0.998237	-0.126034	1.061148	0.000000
20	0.753782	0.551332	-0.048792	0.454498	0.042073	-0.024291	-0.998819	0.042073	-0.024291	-0.998819	-0.145001	1.070066	0.000000
21	0.713306	0.552674	-0.050333	0.413671	0.031616	-0.018254	-0.999333	0.031616	-0.018254	-0.999333	-0.163780	1.078186	0.000000
22	0.673399	0.553977	-0.051390	0.374028	0.019877	-0.011254	-0.999737	0.019877	-0.011254	-0.999737	-0.184011	1.088122	0.000000
23	0.635236	0.555237	-0.051918	0.335861	0.008559	-0.003780	-0.999971	0.008559	-0.003780	-0.999971	-0.204060	1.097297	0.000000
24	0.598793	0.556426	-0.051901	0.299378	0.003362	0.004820	-0.999953	0.003362	0.004820	-0.999953	-0.224279	1.106671	0.000000
25	0.564281	0.557549	-0.051329	0.264853	0.025056	0.014466	-0.999581	0.025056	0.014466	-0.999581	-0.243723	1.115823	0.000000
26	0.531902	0.558590	-0.050212	0.232628	0.043587	0.025165	-0.998733	0.043587	0.025165	-0.998733	-0.261954	1.123367	0.000000
27	0.501816	0.559550	-0.048575	0.202823	0.064045	0.036977	-0.997262	0.064045	0.036977	-0.997262	-0.278244	1.130594	0.000000
28	0.474159	0.560421	-0.046462	0.174531	0.086941	0.050196	-0.994948	0.086941	0.050196	-0.994948	-0.292548	1.136903	0.000000
29	0.449008	0.561198	-0.043908	0.149239	0.112625	0.055024	-0.991508	0.112625	0.055024	-0.991508	-0.301983	1.141044	0.000000
30	0.426425	0.561868	-0.040980	0.126657	0.141537	0.051717	-0.986554	0.141537	0.051717	-0.986554	-0.306438	1.142995	0.000000
31	0.406388	0.562411	-0.037733	0.106151	0.174668	0.040729	-0.979497	0.174668	0.040729	-0.979497	-0.303406	1.141668	0.000000
32	0.388879	0.562794	-0.034243	0.088294	0.212528	0.027202	-0.969421	0.212528	0.027202	-0.969421	-0.291526	1.136453	0.000000
33	0.373816	0.562997	-0.030571	0.072789	0.252538	0.148112	-0.955119	0.252538	0.148112	-0.955119	-0.266591	1.125429	0.000000
34	0.361072	0.562990	-0.026803	0.059500	0.308903	0.178345	-0.934223	0.308903	0.178345	-0.934223	-0.226765	1.107594	0.000000
35	0.350498	0.562724	-0.022984	0.048254	0.371043	0.214222	-0.903559	0.371043	0.214222	-0.903559	-0.162077	1.077997	0.000000
36	0.341899	0.562154	-0.019208	0.038855	0.446606	0.256693	-0.858157	0.446606	0.256693	-0.858157	-0.067981	1.033431	0.000000
37	0.335819	0.561183	-0.015519	0.030978	0.530856	0.306490	-0.790099	0.530856	0.306490	-0.790099	0.64587	0.967168	0.000000
38	0.329592	0.559733	-0.011986	0.024342	0.624244	0.340407	-0.693128	0.624244	0.340407	-0.693128	0.230194	0.873866	0.000000
39	0.325343	0.557777	-0.008695	0.018623	0.716152	0.413470	-0.562288	0.716152	0.413470	-0.562288	0.406276	0.770535	0.000000
40	0.321674	0.554732	-0.005166	0.013001	0.793461	0.458105	-0.400699	0.793461	0.458105	-0.400699	0.558761	0.664258	0.000000
41	0.317686	0.549522	-0.003135	0.005950	0.841699	0.485955	-0.235352	0.841699	0.485955	-0.235352	0.654592	0.587714	0.000000
42	0.315219	0.545890	-0.001117	0.001118	0.861861	0.477595	-0.097951	0.861861	0.477595	-0.097951	0.691315	0.555594	0.000000
43	0.315182	0.545911	0.000000	0.000000	0.866026	0.500000	0.000000	0.866026	0.500000	0.000000	0.697187	0.550284	0.000000
44	0.315219	0.545890	0.001117	-0.001118	0.861861	0.477595	0.097951	-0.861861	0.477595	0.097951	0.691306	0.555503	0.000000
45	0.320435	0.554460	0.003135	-0.011404	0.841699	0.485955	0.235352	-0.841699	0.485955	0.235352	0.653575	0.588579	0.000000
46	0.324135	0.558904	0.005716	-0.017741	0.793461	0.458105	0.400699	-0.793461	0.458105	0.400699	0.557773	0.565001	0.000000
47	0.327594	0.561573	0.008695	-0.022945	0.716152	0.413470	0.562288	-0.716152	0.413470	0.562288	0.450508	0.665001	0.000000
48	0.331729	0.563435	0.011986	-0.028593	0.624244	0.340407	0.693128	-0.624244	0.340407	0.693128	0.228738	0.771325	0.000000
49	0.337113	0.564810	0.015519	-0.035177	0.530512	0.306291	0.790407	-0.530512	0.306291	0.790407	0.062955	0.868011	0.000000
50	0.343917	0.565648	0.019200	-0.042959	0.444557	0.256665	0.858157	-0.444557	0.256665	0.858157	-0.068819	1.033837	0.000000
51	0.352474	0.566146	0.022984	-0.052328	0.371091	0.214249	0.903542	-0.371091	0.214249	0.903542	-0.163435	1.078626	0.000000
52	0.363024	0.566370	0.026795	-0.0563547	0.308959	0.178377	0.934198	-0.308959	0.178377	0.934198	-0.226983	1.107693	0.000000

Figure 26. - Continued.

53	0.375743	0.563352	0.030571	-0.076815	-0.256906	0.148324	0.954987	-0.267883	1.126003	0.000000
54	0.390792	0.566125	0.036243	-0.092308	-0.212475	0.122672	0.969436	-0.292545	1.136902	0.000000
55	0.408298	0.565718	0.037733	-0.110162	-0.174268	0.100613	0.979545	-0.304001	1.141928	0.000000
56	0.428320	0.565169	0.040972	-0.130452	-0.141528	0.081711	0.986556	-0.305842	1.142734	0.000000
57	0.450912	0.564696	0.043908	-0.153244	-0.112786	0.065117	0.991483	-0.301996	1.141051	0.000000
58	0.476054	0.563720	0.046462	-0.178527	-0.086961	0.050207	0.994946	-0.292221	1.136759	0.000000
59	0.503711	0.562850	0.048575	-0.206279	-0.064045	0.036977	0.997262	-0.277597	1.130308	0.000000
60	0.533802	0.561899	0.050212	-0.236429	-0.045097	0.025165	0.998733	-0.261123	1.122997	0.000000
61	0.566177	0.560851	0.051329	-0.268061	-0.025504	0.014466	0.999501	-0.242702	1.114001	0.000000
62	0.600693	0.559735	0.051901	-0.303379	-0.008362	0.004828	0.999953	-0.223290	1.106025	0.000000
63	0.637135	0.558544	0.051918	-0.339841	0.006551	-0.003788	0.999971	-0.203053	1.096838	0.000000
64	0.675290	0.557288	0.051390	-0.378020	0.019764	-0.011411	0.999740	-0.182633	1.087581	0.000000
65	0.714900	0.555972	0.050342	-0.417666	0.031610	-0.018250	0.999334	-0.163561	1.078685	0.000000
66	0.755669	0.554619	0.048792	-0.458487	0.042181	-0.024353	0.998813	-0.143997	1.069578	0.000000
67	0.797302	0.553237	0.046791	-0.500190	0.051396	-0.029674	0.998237	-0.125249	1.060777	0.000000
68	0.839479	0.551848	0.044392	-0.542459	0.059559	-0.034386	0.997632	-0.107504	1.052380	0.000000
69	0.881860	0.550480	0.041647	-0.584950	0.066732	-0.038528	0.997027	-0.090101	1.044079	0.000000
70	0.924092	0.549150	0.038625	-0.627311	0.073220	-0.042274	0.996419	-0.074277	1.036474	0.000000
71	0.965832	0.547886	0.035368	-0.669197	0.078955	-0.045585	0.995835	-0.057897	1.028541	0.000000
72	1.006694	0.546678	0.031965	-0.710219	0.084074	-0.048560	0.995277	-0.043195	1.021369	0.000000
73	1.046359	0.545613	0.028498	-0.750053	0.089020	-0.051396	0.994703	-0.028205	1.014004	0.000000
74	1.084445	0.544670	0.024907	-0.788315	0.093515	-0.053991	0.994153	-0.012676	1.006318	0.000000
75	1.120667	0.543947	0.021382	-0.824715	0.097737	-0.056428	0.993611	0.002723	0.998637	0.000000
76	1.154571	0.543277	0.017935	-0.858801	0.101703	-0.058719	0.993080	0.019434	0.990235	0.000000
77	1.185892	0.542744	0.014636	-0.890300	0.105440	-0.060876	0.992561	0.036771	0.981442	0.000000
78	1.214423	0.542502	0.011535	-0.919000	0.109024	-0.062946	0.992044	0.056191	0.971498	0.000000
79	1.239799	0.542391	0.008695	-0.944534	0.112265	-0.064817	0.991562	0.077835	0.960294	0.000000
80	1.261850	0.542567	0.006175	-0.966730	0.115186	-0.066504	0.991115	0.102425	0.947404	0.000000
81	1.280197	0.542716	0.004027	-0.985202	0.117890	-0.068065	0.990691	0.131104	0.932146	0.000000
82	1.294756	0.543009	0.002295	-0.999867	0.119904	-0.069227	0.990369	0.166370	0.913033	0.000000
83	1.305361	0.543401	0.001031	-1.010555	0.121169	-0.069957	0.990164	0.202089	0.888657	0.000000
84	1.311835	0.543754	0.000260	-1.017084	0.122154	-0.070526	0.990002	0.251984	0.866497	0.000000
85	1.313000	0.543866	0.000000	-1.019267	0.061436	-0.035470	0.997481	0.251407	0.865213	0.000000
86	1.322258	0.544312	0.000000	-1.027537	0.000000	0.000000	1.000000	0.170888	0.884823	0.000000
87	1.334513	0.544754	0.000000	-1.035601	0.000000	0.000000	1.000000	0.170327	0.910864	0.000000
88	1.364833	0.545308	0.000000	-1.070125	0.000000	0.000000	1.000000	0.119701	0.938242	0.000000

*** SUBROUTINE STREAM3D COMPLETE ***

CPU TIME = 556.650

TRAJECTORY DATA ARE WRITTEN ON UNIT 10 FOR PLOTTING

WATER DROP DIAMETER =
PARTICLE SETTLING SPEED=

2.00000E+01 MICROMETERS
1.93333E-04 M/SEC

*** SUBROUTINE CONFAC BEGINS ***

Figure 26. - Continued.

*** SUBROUTINE CONFAC RUNS COMPLETE, CPU TIME = 594.427 SECONDS ***

***** OUTPUT FROM SUBROUTINE CONFAC FOR ICEC= 2

XSCI	YSCI	ZSCI	XSCF	YSCF	ZSCF
-20.00000	0.53191	0.04405	0.31800	0.54997	0.05101
-20.00000	0.53242	-0.05314	0.31800	0.54992	-0.06080

*** SUBROUTINE IMPLIM BEGINS ***

*** SUBROUTINE IMPLIM RUNS COMPLETE, CPU TIME = 784.205 SECONDS ***

***** OUTPUT FROM SUBROUTINE IMPLIM FOR ICEC= 2

XTIP	YTIP	ZTIP	XTIF	YTIF	ZTIF
-20.00000	0.53206	0.01643	0.36962	0.55757	0.03026
-20.00000	0.53223	-0.01632	0.36887	0.55760	-0.03002

SUBROUTINE ARYTRJ INPUT FOR SLICE: 2

ROW (NBRC)	COLUMN (NBCC)	X(NBRC,NBCC)	Y(NBRC,NBCC)	Z(NBRC,NBCC)
1	1	-20.000000	0.532056	0.016432
2	1	-20.000000	0.532065	0.014709
3	1	-20.000000	0.532074	0.012985
4	1	-20.000000	0.532083	0.011262
5	1	-20.000000	0.532092	0.009538
6	1	-20.000000	0.532101	0.007815
7	1	-20.000000	0.532111	0.006091
8	1	-20.000000	0.532120	0.004368
9	1	-20.000000	0.532129	0.002644
10	1	-20.000000	0.532138	0.000920
11	1	-20.000000	0.532147	-0.000803
12	1	-20.000000	0.532156	-0.002527
13	1	-20.000000	0.532165	-0.004250
14	1	-20.000000	0.532174	-0.005974
15	1	-20.000000	0.532183	-0.007697
16	1	-20.000000	0.532193	-0.009421
17	1	-20.000000	0.532202	-0.011144
18	1	-20.000000	0.532211	-0.012868

Figure 26. - Continued.

```

19          1          -20.000000      0.532220      -0.014592
20          1          -20.000000      0.532229      -0.016315

```

*** SUBROUTINE ARYTRJ BEGINS ***

*** SUBROUTINE ARYTRJ RUNS COMPLETE, CPU TIME = 957.490 SECONDS ***

***** OUTPUT FROM SUBROUTINE ARYTRJ FOR ICEC= 2

XBLI	YBLI	ZBLI	XBLF	YBLF	ZBLF	TNORMX	TNORMY	TNORMZ
-20.00000	0.53206	0.01643	0.36962	0.55757	0.03026	-0.96789	-0.07747	-0.23912
-20.00000	0.53207	0.01471	0.34634	0.55569	0.02294	-0.96890	-0.11380	-0.21972
-20.00000	0.53207	0.01299	0.33761	0.55492	0.01913	-0.97064	-0.13279	-0.20054
-20.00000	0.53208	0.01126	0.33196	0.55400	0.01602	-0.97253	-0.14775	-0.17989
-20.00000	0.53209	0.00954	0.32791	0.55302	0.01323	-0.97451	-0.16022	-0.15704
-20.00000	0.53210	0.00781	0.32483	0.55212	0.01062	-0.97646	-0.17103	-0.13144
-20.00000	0.53211	0.00609	0.32251	0.55148	0.00815	-0.97831	-0.17970	-0.10301
-20.00000	0.53212	0.00437	0.32089	0.55082	0.00577	-0.97990	-0.18530	-0.07383
-20.00000	0.53213	0.00264	0.31995	0.55023	0.00345	-0.98090	-0.18921	-0.04520
-20.00000	0.53214	0.00092	0.31944	0.55318	0.00116	-0.98164	-0.19013	-0.01538
-20.00000	0.53215	-0.00080	0.31943	0.55319	-0.00111	-0.98165	-0.19014	0.01469
-20.00000	0.53216	-0.00253	0.31994	0.55325	-0.00340	-0.98094	-0.18918	0.04440
-20.00000	0.53217	-0.00425	0.32088	0.55336	-0.00571	-0.97991	-0.18552	0.07319
-20.00000	0.53218	-0.00597	0.32251	0.55354	-0.00809	-0.97834	-0.17989	0.10243
-20.00000	0.53219	-0.00770	0.32482	0.55380	-0.01057	-0.97650	-0.17124	0.13084
-20.00000	0.53220	-0.00942	0.32788	0.55411	-0.01317	-0.97455	-0.16053	0.15648
-20.00000	0.53221	-0.01114	0.33190	0.55451	-0.01595	-0.97256	-0.14818	0.17934
-20.00000	0.53222	-0.01287	0.33754	0.55505	-0.01906	-0.97060	-0.13329	0.20041
-20.00000	0.53223	-0.01459	0.34624	0.55583	-0.02286	-0.96887	-0.11425	0.21965
-20.00000	0.53223	-0.01632	0.36887	0.55768	-0.03002	-0.96787	-0.07854	0.23888

SUBROUTINE BETAC OUTPUT FOR SLICE: 2

ROW (NIL)	COLUMN (NJL)	X(NBRC,NBCC)	Y(NBRC,NBCC)	Z(NBRC,NBCC)	BETA(NBRC,NBCC)	BNORMX	BNORMY	BNORMZ
1	1	0.35790	0.55663	0.02660	0.07257	-0.96860	-0.09564	-0.22942
2	1	0.34190	0.55530	0.02104	0.18368	-0.96986	-0.12330	-0.21013
3	1	0.33479	0.55466	0.01758	0.26742	-0.97167	-0.14027	-0.19021
4	1	0.32994	0.55421	0.01462	0.34426	-0.97360	-0.15399	-0.16846
5	1	0.32637	0.55387	0.01193	0.41194	-0.97558	-0.16563	-0.14424
6	1	0.32367	0.55360	0.00938	0.47941	-0.97749	-0.17537	-0.11723
7	1	0.32170	0.55340	0.00696	0.54811	-0.97922	-0.18250	-0.08842
8	1	0.32042	0.55327	0.00461	0.61170	-0.98050	-0.18726	-0.05952
9	1	0.31969	0.55320	0.00231	0.64200	-0.98138	-0.18967	-0.03029
10	1	0.31943	0.55318	0.00003	0.65575	-0.98175	-0.19014	-0.00035
11	1	0.31969	0.55322	-0.00226	0.64263	-0.98140	-0.18966	0.02954

Figure 26. - Continued.

POINT	XSTRM	YSTRM	ZSTRM	SSTRM	XNSTRM	YNSTRM	ZNSTRM	CPSTRM	VSTRM	BSTRM
12	1	0.32061	0.55330	0.00456	0.61294	-0.98053	-0.18735	0.05879		
13	1	0.32170	0.55345	-0.00690	0.54830	-0.97923	-0.18270	0.08781		
14	1	0.32366	0.55367	-0.00933	0.48135	-0.97753	-0.17557	0.11664		
15	1	0.32635	0.55396	-0.01187	0.41412	-0.97562	-0.16589	0.14366		
16	1	0.32989	0.55431	-0.01456	0.34697	-0.97364	-0.15436	0.16791		
17	1	0.33472	0.55478	-0.01750	0.26819	-0.97166	-0.14074	0.18988		
18	1	0.34189	0.55544	-0.02096	0.18458	-0.96982	-0.12377	0.21003		
19	1	0.35755	0.55676	-0.02644	0.07464	-0.96857	-0.09639	0.22927		
20	1	0.00000	1.01545	0.12256	-0.07076	-0.98993	0.25213	0.86480		
21	1	-0.00026	1.01325	0.12215	-0.07053	-0.99000	0.24978	0.86615		
22	1	0.00103	1.00722	0.12117	-0.06996	-0.99016	0.24937	0.88611		
23	1	-0.00230	0.99603	0.11990	-0.06923	-0.99037	0.16644	0.91299		
24	1	-0.00403	0.98435	0.11792	-0.06808	-0.99069	0.13117	0.93211		
25	1	0.00018	0.96289	0.11519	-0.06651	-0.99111	0.10237	0.94744		
26	1	0.00870	0.94069	0.11226	-0.06481	-0.99156	0.07786	0.96028		
27	1	-0.01154	0.91533	0.10905	-0.06296	-0.99204	0.05608	0.97156		
28	1	-0.01464	0.88644	0.10544	-0.06087	-0.99256	0.03663	0.98152		
29	1	0.01794	0.85497	0.10170	-0.05872	-0.99308	0.01924	0.99033		
30	1	-0.02138	0.82076	0.09774	-0.05643	-0.99361	0.00245	0.99878		
31	1	0.02491	0.78441	0.09340	-0.05392	-0.99417	0.01315	0.99855		
32	1	-0.02845	0.74616	0.08902	-0.05139	-0.99470	-0.02754	1.00655		
33	1	-0.03197	0.70629	0.08418	-0.04860	-0.99526	-0.04300	1.01387		
34	1	-0.03537	0.66525	0.07896	-0.04558	-0.99584	-0.05840	1.02167		
35	1	-0.03863	0.62336	0.07322	-0.04227	-0.99642	-0.07483	1.02878		
36	1	0.04165	0.58097	0.06673	-0.03853	-0.99703	-0.09072	1.03674		
37	1	-0.04439	0.53848	0.05956	-0.03439	-0.99763	-0.10820	1.04438		
38	1	-0.04679	0.49621	0.05140	-0.02967	-0.99824	-0.12603	1.05271		
39	1	-0.04879	0.45450	0.04207	-0.02429	-0.99882	-0.14504	1.06115		
40	1	-0.05033	0.41367	0.03162	-0.01825	-0.99933	-0.16378	1.07007		
41	1	-0.05139	0.37403	0.01988	-0.01148	-0.99974	-0.18401	1.07879		
42	1	-0.05192	0.33584	0.00856	-0.00379	-0.99997	-0.20406	1.08812		
43	1	-0.05190	0.29938	-0.00636	0.00483	-0.99995	-0.22428	1.09730		
44	1	-0.05133	0.26484	0.02506	0.01447	-0.99958	-0.24372	1.10647		
45	1	-0.05021	0.23243	-0.04359	0.02517	-0.99873	-0.26195	1.11522		
46	1	0.04858	0.20228	0.06495	0.03698	-0.99726	-0.27824	1.12337		
47	1	-0.04646	0.17453	-0.08694	0.05020	-0.99495	-0.29255	1.13059		
48	1	-0.04391	0.14924	0.08502	0.06502	-0.99151	-0.30198	1.13690		
49	1	-0.04098	0.12646	-0.11454	0.08172	-0.98655	-0.30344	1.14104		
50	1	-0.03773	0.10615	-0.14154	0.09173	-0.97950	-0.30644	1.14300		
51	1	-0.03424	0.08829	-0.17447	0.10073	-0.97153	-0.30341	1.14167		
52	1	-0.03057	0.07279	-0.21253	0.12270	-0.96142	-0.29153	1.13665		
53	1	-0.02680	0.05950	-0.25654	0.14811	-0.95512	-0.26659	1.12543		
54	1	0.05950	0.05950	-0.30890	0.17835	-0.93422	-0.22677	1.10759		

*** SUBROUTINE BETAC COMPLETE ***
CPU TIME = 957.581

SUBROUTINE BSTREM OUTPUT FOR SLICE: 2

Figure 26. - Continued.

35	0.35050	0.56272	-0.02298	0.04825	-0.37104	0.21422	-0.90357	-0.16208	1.07800	0.15084
36	0.34190	0.56215	-0.01921	0.03085	-0.64461	0.23469	-0.85016	-0.06798	1.03343	0.23085
37	0.32502	0.56118	-0.01552	0.03098	-0.53086	0.30649	-0.79010	0.06459	0.96717	0.32490
38	0.32299	0.55773	-0.01199	0.02434	-0.62424	0.41347	-0.56229	0.23019	0.87739	0.41337
39	0.32534	0.55778	-0.00870	0.01862	-0.71615	0.41347	-0.40070	0.40628	0.77054	0.50117
40	0.32167	0.55473	-0.00572	0.01300	-0.79346	0.45810	-0.23535	0.55876	0.66426	0.58234
41	0.31769	0.54952	-0.00314	0.00595	-0.84170	0.48595	-0.09975	0.65459	0.58771	0.62160
42	0.31522	0.54589	-0.00112	0.00112	-0.86186	0.49760	-0.00000	0.69719	0.55559	0.64923
43	0.31518	0.54591	0.00000	0.00000	-0.86603	0.50000	0.00000	0.69719	0.55559	0.64923
44	0.31522	0.54589	0.00112	-0.00112	-0.86186	0.49760	0.00000	0.69719	0.55559	0.64923
45	0.32054	0.55446	0.00314	-0.01140	-0.84170	0.48595	0.23535	0.65357	0.58558	0.62146
46	0.32589	0.55999	0.00572	-0.01774	-0.79346	0.45810	0.40070	0.55777	0.66500	0.58307
47	0.32753	0.56157	0.00870	-0.02294	-0.71615	0.41347	0.56229	0.40506	0.77132	0.50131
48	0.33173	0.56344	0.01199	-0.02859	-0.62424	0.36041	0.93420	0.22874	0.87322	0.41300
49	0.33711	0.56481	0.01552	-0.03518	-0.53051	0.30629	0.79041	0.06295	0.96801	0.32455
50	0.34392	0.56615	0.01920	-0.04296	-0.44456	0.25666	0.85819	0.06882	1.03584	0.23189
51	0.35247	0.56615	0.02298	-0.05233	-0.37109	0.21425	0.90354	-0.16343	1.07863	0.07560
52	0.36302	0.56637	0.02680	-0.06355	-0.30896	0.17838	0.93420	-0.22698	1.10769	0.00000
53	0.37574	0.56635	0.03057	-0.07682	-0.25624	0.14832	0.95499	-0.29255	1.13690	0.00000
54	0.39079	0.56613	0.03424	-0.09231	-0.21247	0.12267	0.96944	-0.30400	1.14193	0.00000
55	0.40830	0.56572	0.03773	-0.11016	-0.17427	0.10061	0.97954	-0.30584	1.14273	0.00000
56	0.42832	0.56517	0.04097	-0.13045	-0.14153	0.08171	0.98656	-0.30584	1.14105	0.00000
57	0.45091	0.56450	0.04391	-0.15324	-0.11279	0.05112	0.99148	-0.29222	1.13676	0.00000
58	0.47605	0.56372	0.04646	-0.17853	-0.08696	0.03021	0.99426	-0.27760	1.13531	0.00000
59	0.50371	0.56285	0.04858	-0.20628	-0.06405	0.02091	0.99726	-0.26112	1.12300	0.00000
60	0.53380	0.56190	0.05021	-0.23643	-0.04359	0.02517	0.99873	-0.24278	1.11480	0.00000
61	0.56618	0.56085	0.05133	-0.26884	-0.02506	0.01447	0.99955	-0.22329	1.10602	0.00000
62	0.60069	0.55974	0.05190	-0.30338	-0.00836	0.00483	0.99995	-0.20305	1.09584	0.00000
63	0.63714	0.55854	0.05192	-0.33984	0.00656	-0.00379	0.99974	-0.18283	1.08758	0.00000
64	0.67529	0.55729	0.05139	-0.37802	0.01976	-0.01141	0.99933	-0.16356	1.07869	0.00000
65	0.71490	0.55597	0.05034	-0.41767	0.03131	-0.01825	0.99881	-0.14400	1.06958	0.00000
66	0.75567	0.55462	0.04879	-0.45849	0.04218	-0.02435	0.99824	-0.12525	1.06078	0.00000
67	0.79730	0.55324	0.04679	-0.50019	0.05140	-0.02967	0.99763	-0.10750	1.05238	0.00000
68	0.83948	0.55185	0.04439	-0.54246	0.05956	-0.03439	0.99703	-0.09010	1.04408	0.00000
69	0.88186	0.55048	0.04165	-0.58495	0.06673	-0.03853	0.99642	-0.07428	1.03647	0.00000
70	0.92409	0.54915	0.03863	-0.62731	0.07322	-0.04227	0.99584	-0.05790	1.02854	0.00000
71	0.96583	0.54789	0.03537	-0.66920	0.07896	-0.04558	0.99528	-0.04320	1.02137	0.00000
72	1.00669	0.54668	0.03197	-0.71022	0.08407	-0.04854	0.99470	-0.02820	1.01400	0.00000
73	1.04636	0.54561	0.02846	-0.75005	0.08902	-0.05140	0.99415	-0.01268	1.00632	0.00000
74	1.08445	0.54467	0.02491	-0.78832	0.09351	-0.05399	0.99361	0.00272	0.99864	0.00000
75	1.12067	0.54395	0.02138	-0.82472	0.09774	-0.05643	0.99308	0.01943	0.99024	0.00000
76	1.15457	0.54328	0.01794	-0.85880	0.10170	-0.05872	0.99256	0.03677	0.98144	0.00000
77	1.18589	0.54274	0.01464	-0.89030	0.10544	-0.06088	0.99204	0.05619	0.97150	0.00000
78	1.21442	0.54250	0.01154	-0.91900	0.10902	-0.06295	0.99156	0.07763	0.96029	0.00000
79	1.23980	0.54239	0.00870	-0.94453	0.11226	-0.06482	0.99112	0.10243	0.94740	0.00000
80	1.26185	0.54257	0.00618	-0.96673	0.11519	-0.06650	0.99069	0.13110	0.93215	0.00000
81	1.28020	0.54272	0.00403	-0.98520	0.11789	-0.06806	0.99037	0.16310	0.91303	0.00000
82	1.29476	0.54301	0.00230	-0.99987	0.11990	-0.06923	0.99016	0.21029	0.88866	0.00000
83	1.30536	0.54375	0.00103	-1.01055	0.12117	-0.06996	0.99000	0.24918	0.86650	0.00000
84	1.31184	0.54315	0.00026	-1.01708	0.12215	-0.07053	0.99748	0.25141	0.86521	0.00000
85	1.31400	0.54337	0.00000	-1.01927	0.06144	-0.05547	1.00000	0.17033	0.88482	0.00000
86	1.32226	0.54451	0.00000	-1.02754	0.00000	0.00000	1.00000	0.21709	0.91086	0.00000
87	1.33451	0.54475	0.00000	-1.03980	0.00000	0.00000	1.00000	0.30620	0.93824	0.00000
88	1.36483	0.54531	0.00000	-1.07013	0.00000	0.00000	1.00000	0.40506	0.96801	0.00000

Figure 26. - Continued.

*** SUBROUTINE BSTREM COMPLETE ***

CPU TIME = 957.692

SUBROUTINE STREMS3D OUTPUT FOR SLICE: 3

POINT	XSTRM	YSTRM	ZSTRM	SSTRM	XNSTRM	YNSTRM	ZNSTRM	CPSTRM	VSTRM	BSTRM
1	1.995758	-0.526717	-0.000226	2.350709	0.122563	-0.070762	-0.989935	0.005291	0.997351	0.000000
2	1.563167	-0.527861	-0.000226	1.918117	0.122154	-0.070526	-0.990002	0.009499	0.995239	0.000000
3	1.275479	-0.529434	-0.000227	1.630425	0.121169	-0.069957	-0.990164	0.015103	0.992420	0.000000
4	1.084315	-0.531220	-0.000229	1.439252	0.119904	-0.069227	-0.990369	0.022493	0.988690	0.000000
5	0.957328	-0.533012	-0.000230	1.312352	0.117921	-0.068082	-0.990686	0.032145	0.983796	0.000000
6	0.873309	-0.534664	-0.000232	1.228217	0.115192	-0.066506	-0.991114	0.043883	0.977812	0.000000
7	0.817602	-0.536090	-0.000235	1.172492	0.112261	-0.064813	-0.991563	0.057131	0.971004	0.000000
8	0.780739	-0.537260	-0.000237	1.135611	0.109045	-0.062957	-0.992041	0.071093	0.963798	0.000000
9	0.756352	-0.538180	-0.000240	1.111206	0.105439	-0.060875	-0.992561	0.084789	0.956667	0.000000
10	0.740215	-0.538879	-0.000242	1.095054	0.101703	-0.058718	-0.993080	0.097425	0.950039	0.000000
11	0.724215	-0.539669	-0.000246	1.079034	0.097737	-0.056429	-0.993611	0.115030	0.940997	0.000000
12	0.713656	-0.540266	-0.000249	1.068459	0.093400	-0.053925	-0.994167	0.131924	0.931706	0.000000
13	0.706685	-0.540707	-0.000252	1.061474	0.089015	-0.051392	-0.994704	0.147316	0.923409	0.000000
14	0.702079	-0.541027	-0.000258	1.053801	0.084184	-0.048603	-0.995264	0.160816	0.916070	0.000000
15	0.699032	-0.541254	-0.000258	1.045381	0.078955	-0.045585	-0.995835	0.172158	0.909858	0.000000
16	0.696010	-0.541496	-0.000261	1.035070	0.073320	-0.042274	-0.996410	0.186516	0.901933	0.000000
17	0.694013	-0.541668	-0.000264	1.024875	0.066732	-0.038528	-0.997027	0.198739	0.895132	0.000000
18	0.692691	-0.541789	-0.000267	1.014743	0.059559	-0.034386	-0.997632	0.208740	0.889528	0.000000
19	0.691379	-0.541915	-0.000270	1.004612	0.051396	-0.029674	-0.998237	0.220931	0.882669	0.000000
20	0.690074	-0.542045	-0.000275	0.994480	0.042073	-0.024291	-0.998819	0.222956	0.881501	0.000000
21	0.688770	-0.542176	-0.000282	0.984348	0.031816	-0.018254	-0.999333	0.223879	0.880977	0.000000
22	0.687467	-0.542308	-0.000294	0.974218	0.019877	-0.011476	-0.999737	0.224187	0.880802	0.000000
23	0.686164	-0.542439	-0.000371	0.964087	0.006559	-0.003787	-0.999971	0.224877	0.880487	0.000000
24	0.683726	-0.542686	-0.000629	0.938412	-0.008362	0.004828	-0.999953	0.214522	0.886272	0.000000
25	0.677986	-0.543228	-0.001285	0.932609	-0.025056	0.014466	-0.999581	0.179369	0.905087	0.000000
26	0.657135	-0.544695	-0.003691	0.911560	-0.043307	0.025165	-0.998733	0.107683	0.944655	0.000000
27	0.616637	-0.546653	-0.008203	0.970764	-0.064045	0.036977	-0.997262	-0.046148	0.976653	0.000000
28	0.538332	-0.549135	-0.016650	0.891974	-0.086941	0.050196	-0.994948	-0.015147	1.007545	0.000000
29	0.484991	-0.550317	-0.021960	0.838356	-0.112625	0.065024	-0.991508	-0.062301	1.021080	0.000000
30	0.431006	-0.551210	-0.027035	0.784126	-0.141537	0.081717	-0.986554	-0.062301	1.030680	0.000000
31	0.394721	-0.551652	-0.030257	0.747696	-0.174468	0.100729	-0.979497	-0.074560	1.036610	0.000000
32	0.358216	-0.551960	-0.033362	0.711057	-0.212526	0.122702	-0.969421	-0.086273	1.042244	0.000000
33	0.321518	-0.552137	-0.036309	0.674241	-0.256538	0.148112	-0.955119	-0.097342	1.047541	0.000000
34	0.284621	-0.552163	-0.039098	0.637239	-0.308903	0.178345	-0.934223	-0.109889	1.053513	0.074006
35	0.247529	-0.552028	-0.041706	0.600055	-0.371043	0.214222	-0.903569	-0.120007	1.058304	0.150842
36	0.210246	-0.551720	-0.044122	0.562692	-0.444606	0.256693	-0.858157	-0.130526	1.063262	0.230855
37	0.172760	-0.551221	-0.046184	0.525124	-0.530856	0.306490	-0.790099	-0.141054	1.068201	0.324898
38	0.135050	-0.550512	-0.048184	0.487386	-0.624244	0.360407	-0.693128	-0.152442	1.073519	0.413368
39	0.097138	-0.549576	-0.049742	0.449420	-0.716152	0.413470	-0.562288	-0.164221	1.078991	0.501173
40	0.059022	-0.548415	-0.051046	0.411264	-0.793461	0.458105	-0.406699	-0.176485	1.084659	0.581235
41	0.020687	-0.547003	-0.051919	0.372894	-0.841699	0.485955	-0.235352	-0.189272	1.090537	0.631602
42	-0.017857	-0.545334	-0.052277	0.334312	-0.861861	0.497595	-0.097951	-0.202014	1.096364	0.649228
43	-0.056604	-0.543399	-0.051865	0.295515	-0.866026	0.500000	0.000000	-0.215025	1.102282	0.655933

Figure 26. - Continued.

44	-0.082539	-0.051281	0.269534	-0.861861	0.497595	0.097951	-0.223513	1.106125	0.649235
45	-0.108521	-0.050256	0.243486	-0.841699	0.485955	0.233352	-0.234599	1.111125	0.631455
46	-0.134541	-0.047829	0.217369	-0.793461	0.458105	0.400599	-0.243442	1.111507	0.583072
47	-0.151899	-0.047398	0.199223	-0.716152	0.413470	0.562288	-0.244134	1.115408	0.501311
48	-0.136646	-0.045742	0.184333	-0.624244	0.360407	0.624328	-0.244684	1.115654	0.412999
49	-0.108625	-0.043832	0.164932	-0.530512	0.306291	0.790407	-0.251260	1.118597	0.324555
50	-0.198158	-0.042318	0.153245	-0.444557	0.256665	0.858191	-0.247516	1.116922	0.231887
51	-0.093630	-0.040672	0.141588	-0.371091	0.214249	0.903542	-0.247516	1.117848	0.151572
52	-0.0333101	-0.039415	0.133822	-0.308959	0.178377	0.934198	-0.243311	1.115039	0.075596
53	-0.032746	-0.038548	0.128643	-0.256906	0.148324	0.954987	-0.240487	1.118252	0.000000
54	-0.032390	-0.037649	0.123459	-0.212475	0.122672	0.969436	-0.241221	1.114101	0.000000
55	-0.0320163	-0.036982	0.120014	-0.174268	0.100613	0.979545	-0.238077	1.112689	0.000000
56	-0.031886	-0.036130	0.117277	-0.141528	0.081711	0.986556	-0.234401	1.111036	0.000000
57	-0.031540	-0.035039	0.110381	-0.112786	0.065117	0.991483	-0.234401	1.113327	0.000000
58	-0.031209	-0.033885	0.105045	-0.084961	0.050207	0.994946	-0.225339	1.1106950	0.000000
59	-0.030899	-0.032581	0.099733	-0.064045	0.036977	0.997622	-0.217267	1.103298	0.000000
60	-0.030498	-0.031709	0.094195	-0.043587	0.025165	0.998733	-0.208889	1.104938	0.000000
61	-0.030498	-0.030815	0.092660	-0.0235056	0.014466	0.999581	-0.208060	1.099118	0.000000
62	-0.030326	-0.029833	0.089150	-0.008362	0.004828	0.999953	-0.197619	1.094358	0.000000
63	-0.030163	-0.028822	0.085649	0.006561	-0.003780	0.999971	-0.190116	1.090924	0.000000
64	-0.030007	-0.027779	0.082152	0.019764	-0.011411	0.999740	-0.188866	1.090351	0.000000
65	-0.029863	-0.026714	0.078671	0.031610	-0.018250	0.999334	-0.186177	1.075257	0.000000
66	-0.029701	-0.025540	0.073228	0.042181	-0.024353	0.998813	-0.184693	1.072750	0.000000
67	-0.029548	-0.024338	0.072940	0.051396	-0.029674	0.998237	-0.184693	1.069903	0.000000
68	-0.029358	-0.023919	0.070657	0.059559	-0.034386	0.997532	-0.184693	1.065763	0.000000
69	-0.029166	-0.023373	0.069141	0.067532	-0.038528	0.997227	-0.182648	1.062378	0.000000
70	-0.028960	-0.022796	0.067643	0.073220	-0.042274	0.996419	-0.180958	1.043833	0.000000
71	-0.028753	-0.022195	0.066158	0.078955	-0.045585	0.995577	-0.178379	1.042259	0.000000
72	-0.0285033	-0.021038	0.064385	0.084074	-0.048540	0.994703	-0.175257	1.038450	0.000000
73	-0.0282696	-0.020256	0.061547	0.089020	-0.051396	0.994153	-0.172746	1.030896	0.000000
74	-0.028067	-0.018758	0.058161	0.093515	-0.053991	0.993611	-0.170208	0.994883	0.000000
75	-0.0278596	-0.017145	0.054869	0.097737	-0.056428	0.993080	-0.167879	0.984484	0.000000
76	-0.027462	-0.016063	0.052707	0.101703	-0.058719	0.992561	-0.165082	0.968977	0.000000
77	-0.026191	-0.014933	0.050631	0.105440	-0.060876	0.992044	-0.162296	0.921508	0.000000
78	-0.0257836	-0.013773	0.048601	0.109024	-0.062946	0.991562	-0.159922	0.909949	0.000000
79	-0.0253067	-0.012999	0.047267	0.112265	-0.064817	0.991115	-0.157221	0.897095	0.000000
80	-0.024949	-0.012233	0.045956	0.115186	-0.066504	0.990691	-0.154512	0.870553	0.000000
81	-0.024622	-0.011539	0.044718	0.117890	-0.068065	0.990369	-0.151812	0.823096	0.000000
82	-0.024356	-0.011044	0.043512	0.119904	-0.069427	0.990164	-0.149178	0.814875	0.000000
83	-0.0240654	-0.010420	0.042429	0.121169	-0.070957	0.990002	-0.146541	0.798194	0.000000
84	-0.0237671	-0.009515	0.041457	0.122154	-0.072626	0.990002	-0.143817	0.787057	0.000000
85	-0.0234187	-0.008892	0.040505	0.061436	-0.035470	0.990000	-0.141287	0.747471	0.000000
86	-0.0232493	-0.008350	0.039612	0.000000	0.000000	1.000000	-0.138700	0.706976	0.000000
87	-0.0230823	-0.006696	0.036682	0.000000	0.000000	1.000000	-0.136185	0.655843	0.000000
88	-0.0228666	-0.005276	0.034028	0.000000	0.000000	1.000000	-0.133665	0.587039	0.000000
89	-0.022659	-0.004167	0.031591	0.000000	0.000000	1.000000	-0.131144	0.551714	0.000000
90	-0.0224527	-0.003304	0.029275	0.000000	0.000000	1.000000	-0.128622	0.529910	0.000000
91	-0.0222450	-0.002650	0.027028	0.000000	0.000000	1.000000	-0.126101	0.519903	0.000000
92	-0.0220373	-0.002166	0.024809	0.000000	0.000000	1.000000	-0.123580	0.517694	0.000000
93	-0.0218300	-0.001803	0.022573	0.000000	0.000000	1.000000	-0.121059	0.524020	0.000000
94	-0.0216223	-0.001461	0.020363	0.000000	0.000000	1.000000	-0.118538	0.532268	0.000000
95	-0.0214146	-0.001142	0.018153	0.000000	0.000000	1.000000	-0.116017	0.542228	0.000000
96	-0.0212069	-0.000823	0.015943	0.000000	0.000000	1.000000	-0.113496	0.553352	0.000000
97	-0.0209992	-0.000504	0.013733	0.000000	0.000000	1.000000	-0.110975	0.566468	0.000000
98	-0.0207915	-0.000185	0.011523	0.000000	0.000000	1.000000	-0.108454	0.591057	0.000000

Figure 26. - Continued.

99	-0.328255	-0.547277	-0.000961	0.110028	0.000000	0.000000	0.000000	0.000000	0.000000	0.618225	0.617880	0.000000
100	-0.331461	-0.548318	-0.000877	0.006656	0.000000	0.000000	0.000000	0.000000	0.000000	0.596105	0.643346	0.000000
101	-0.337900	-0.550000	-0.000769	0.000000	0.000000	0.000000	0.000000	0.000000	0.000000	0.527967	0.687046	0.000000
102	-0.337900	-0.550000	0.002051	0.000000	0.000000	0.000000	0.000000	0.000000	0.000000	0.526202	0.698330	0.000000
103	-0.331445	-0.548327	0.002336	0.006674	0.000000	0.000000	0.000000	0.000000	0.000000	0.502670	0.646011	0.000000
104	-0.325565	-0.543312	0.002809	0.012909	0.000000	0.000000	0.000000	0.000000	0.000000	0.637914	0.601736	0.000000
105	-0.320322	-0.543917	0.003655	0.018734	0.000000	0.000000	0.000000	0.000000	0.000000	0.677755	0.567667	0.000000
106	-0.315637	-0.541189	0.005332	0.024380	0.000000	0.000000	0.000000	0.000000	0.000000	0.674030	0.574100	0.000000
107	-0.310965	-0.538443	0.008040	0.030407	0.000000	0.000000	0.000000	0.000000	0.000000	0.557040	0.665552	0.000000
108	-0.308114	-0.537173	0.010151	0.034251	0.000000	0.000000	0.000000	0.000000	0.000000	0.441034	0.747640	0.000000
109	-0.304807	-0.536164	0.012580	0.038476	0.000000	0.000000	0.000000	0.000000	0.000000	0.311573	0.829715	0.000000
110	-0.300984	-0.535450	0.015162	0.043144	0.000000	0.000000	0.000000	0.000000	0.000000	0.175172	0.908200	0.000000
111	-0.296709	-0.534992	0.017731	0.048153	0.000000	0.000000	0.000000	0.000000	0.000000	0.061231	0.968901	0.000000
112	-0.292057	-0.534750	0.020207	0.053428	0.000000	0.000000	0.000000	0.000000	0.000000	-0.088805	1.004393	0.000000
113	-0.289433	-0.534698	0.021454	0.056334	0.000000	0.000000	0.000000	0.000000	0.000000	-0.052937	1.026127	0.000000
114	-0.286744	-0.534682	0.022672	0.059286	0.000000	0.000000	0.000000	0.000000	0.000000	-0.075497	1.037061	0.000000
115	-0.284010	-0.534691	0.023868	0.062262	0.000000	0.000000	0.000000	0.000000	0.000000	-0.096657	1.046259	0.000000
116	-0.281206	-0.534740	0.024957	0.065278	0.000000	0.000000	0.000000	0.000000	0.000000	-0.125934	1.061100	0.000000
117	-0.278358	-0.534814	0.026030	0.068323	0.000000	0.000000	0.000000	0.000000	0.000000	-0.138371	1.066945	0.000000
118	-0.274035	-0.534951	0.027579	0.072917	0.000000	0.000000	0.000000	0.000000	0.000000	-0.155281	1.074840	0.000000
119	-0.267398	-0.535242	0.029701	0.079891	0.000000	0.000000	0.000000	0.000000	0.000000	-0.182896	1.087610	0.000000
120	-0.260663	-0.535583	0.031677	0.085917	0.000000	0.000000	0.000000	0.000000	0.000000	-0.202508	1.096589	0.000000
121	-0.253819	-0.535982	0.033460	0.094001	0.000000	0.000000	0.000000	0.000000	0.000000	-0.212609	1.101185	0.000000
122	-0.246929	-0.536402	0.035136	0.101105	0.000000	0.000000	0.000000	0.000000	0.000000	-0.224398	1.106525	0.000000
123	-0.236477	-0.537090	0.037368	0.111815	0.000000	0.000000	0.000000	0.000000	0.000000	-0.231075	1.109538	0.000000
124	-0.225954	-0.537805	0.039356	0.123554	0.000000	0.000000	0.000000	0.000000	0.000000	-0.245376	1.115964	0.000000
125	-0.215376	-0.538539	0.041169	0.133305	0.000000	0.000000	0.000000	0.000000	0.000000	-0.245363	1.114255	0.000000
126	-0.199416	-0.539669	0.043475	0.149471	0.000000	0.000000	0.000000	0.000000	0.000000	-0.242785	1.114803	0.000000
127	-0.183411	-0.540794	0.045490	0.165641	0.000000	0.000000	0.000000	0.000000	0.000000	-0.245810	1.118418	0.000000
128	-0.167388	-0.541900	0.047164	0.181789	0.000000	0.000000	0.000000	0.000000	0.000000	-0.245810	1.116159	0.000000
129	-0.151326	-0.542997	0.048577	0.197949	0.000000	0.000000	0.000000	0.000000	0.000000	-0.238630	1.112937	0.000000
130	-0.127257	-0.544571	0.050274	0.221130	0.000000	0.000000	0.000000	0.000000	0.000000	-0.238668	1.111156	0.000000
131	-0.103236	-0.546050	0.051527	0.242229	0.000000	0.000000	0.000000	0.000000	0.000000	-0.235978	1.110395	0.000000
132	-0.079262	-0.547435	0.052388	0.270259	0.000000	0.000000	0.000000	0.000000	0.000000	-0.223410	1.106079	0.000000
133	-0.055333	-0.548730	0.052902	0.294229	0.000000	0.000000	0.000000	0.000000	0.000000	-0.211564	1.100711	0.000000
134	-0.031458	-0.549931	0.053188	0.318135	0.000000	0.000000	0.000000	0.000000	0.000000	-0.206035	1.098196	0.000000
135	-0.007483	-0.551016	0.053195	0.341935	0.000000	0.000000	0.000000	0.000000	0.000000	-0.203067	1.095932	0.000000
136	0.014020	-0.552007	0.052954	0.365668	0.000000	0.000000	0.000000	0.000000	0.000000	-0.188071	1.089986	0.000000
137	0.039663	-0.552901	0.052556	0.389323	0.000000	0.000000	0.000000	0.000000	0.000000	-0.183860	1.088053	0.000000
138	0.063206	-0.553690	0.051955	0.412887	0.000000	0.000000	0.000000	0.000000	0.000000	-0.174099	1.083559	0.000000
139	0.098391	-0.554712	0.050743	0.448108	0.000000	0.000000	0.000000	0.000000	0.000000	-0.161934	1.077930	0.000000
140	0.133410	-0.555540	0.049234	0.483169	0.000000	0.000000	0.000000	0.000000	0.000000	-0.150797	1.072752	0.000000
141	0.168246	-0.556175	0.047501	0.518054	0.000000	0.000000	0.000000	0.000000	0.000000	-0.140771	1.068069	0.000000
142	0.202901	-0.556629	0.045525	0.552768	0.000000	0.000000	0.000000	0.000000	0.000000	-0.132248	1.064072	0.000000
143	0.237387	-0.556919	0.043345	0.587324	0.000000	0.000000	0.000000	0.000000	0.000000	-0.121412	1.058967	0.000000
144	0.271708	-0.557057	0.040993	0.621726	0.000000	0.000000	0.000000	0.000000	0.000000	-0.110364	1.053738	0.000000
145	0.305876	-0.557060	0.038470	0.655987	0.000000	0.000000	0.000000	0.000000	0.000000	-0.100079	1.048846	0.000000
146	0.339871	-0.556927	0.035832	0.690085	0.000000	0.000000	0.000000	0.000000	0.000000	-0.090242	1.044147	0.000000
147	0.373695	-0.556671	0.033066	0.724023	0.000000	0.000000	0.000000	0.000000	0.000000	-0.081254	1.039834	0.000000
148	0.407410	-0.556279	0.028692	0.74625	0.000000	0.000000	0.000000	0.000000	0.000000	-0.063871	1.031441	0.000000
149	0.441854	-0.554729	0.021669	0.849715	0.000000	0.000000	0.000000	0.000000	0.000000	-0.034344	1.017027	0.000000
150	0.478273	-0.552811	0.014200	0.923538	0.000000	0.000000	0.000000	0.000000	0.000000	0.008107	0.995938	0.000000
151	0.645525	-0.549970	0.006424	0.995270	0.000000	0.000000	0.000000	0.000000	0.000000	0.085263	0.956262	0.000000
152	0.679704	-0.547484	0.002445	1.031751	0.000000	0.000000	0.000000	0.000000	0.000000	0.207349	0.890310	0.000000
153	0.684956	-0.546956	0.002027	1.037056	0.000000	0.000000	0.000000	0.000000	0.000000	0.220902	0.802665	0.000000

Figure 26. - Continued.

POINT	XSTRM	YSTRM	ZSTRM	SSTRM	XNSTRM	YNSTRM	ZNSTRM	CPSTRM	VSTRM	BSTRM
154	0.689190	-0.546536	0.001908	1.041503	0.000000	0.000000	0.000000	0.210611	0.888476	0.000000
155	0.693484	-0.546157	0.001857	1.045614	0.000000	0.000000	0.000000	0.183606	0.903545	0.000000
156	0.697840	-0.545816	0.001826	1.049984	0.000000	0.000000	0.000000	0.165079	0.913740	0.000000
157	0.704454	-0.545352	0.001794	1.056614	0.000000	0.000000	0.000000	0.145326	0.924486	0.000000
158	0.711137	-0.544931	0.001772	1.063310	0.000000	0.000000	0.000000	0.130934	0.932237	0.000000
159	0.721254	-0.544357	0.001749	1.073443	0.000000	0.000000	0.000000	0.114897	0.940799	0.000000
160	0.736578	-0.543593	0.001725	1.088786	0.000000	0.000000	0.000000	0.107812	0.949836	0.000000
161	0.759293	-0.542603	0.001703	1.112022	0.000000	0.000000	0.000000	0.080441	0.958937	0.000000
162	0.794952	-0.541360	0.001601	1.147203	0.000000	0.000000	0.000000	0.063599	0.967670	0.000000
163	0.848159	-0.539859	0.001662	1.200431	0.000000	0.000000	0.000000	0.048173	0.975616	0.000000
164	0.928585	-0.538131	0.001646	1.280877	0.000000	0.000000	0.000000	0.034902	0.982394	0.000000
165	1.049986	-0.536260	0.001633	1.402292	0.000000	0.000000	0.000000	0.024227	0.987812	0.000000
166	1.232965	-0.534389	0.001623	1.585280	0.000000	0.000000	0.000000	0.016187	0.991874	0.000000
167	1.508404	-0.532721	0.001617	1.860724	0.000000	0.000000	0.000000	0.010216	0.994879	0.000000
168	1.922637	-0.531480	0.001613	2.274959	0.000000	0.000000	0.000000	0.005779	0.997106	0.000000
1	0.686880	-0.542340	0.000000	1.035728	0.122563	-0.070762	-0.989935	0.221421	0.882371	0.000000
2	0.684647	-0.542570	-0.000260	1.033468	0.122154	-0.070526	-0.990002	0.218438	0.884060	0.000000
3	0.678010	-0.543206	-0.001031	1.026756	0.121166	-0.069955	-0.990164	0.179252	0.905951	0.000000
4	0.667189	-0.543969	-0.002295	1.015835	0.119901	-0.069225	-0.990369	0.134491	0.930328	0.000000
5	0.652253	-0.544915	-0.004027	1.000769	0.117921	-0.068082	-0.990686	0.097758	0.949864	0.000000
6	0.633478	-0.545825	-0.006175	0.981850	0.115193	-0.066507	-0.991114	0.067033	0.965902	0.000000
7	0.610943	-0.546820	-0.008695	0.959152	0.112261	-0.064814	-0.991563	0.040330	0.979627	0.000000
8	0.585036	-0.547647	-0.011535	0.933077	0.109045	-0.062957	-0.992041	0.016421	0.991755	0.000000
9	0.555832	-0.548571	-0.014636	0.903695	0.105440	-0.060876	-0.992561	-0.004804	1.002399	0.000000
10	0.523696	-0.549449	-0.017935	0.871377	0.101703	-0.058718	-0.993080	-0.023302	1.011584	0.000000
11	0.488962	-0.550218	-0.021382	0.836464	0.097377	-0.056428	-0.993611	-0.040377	1.019989	0.000000
12	0.451954	-0.550655	-0.024907	0.799283	0.093400	-0.054924	-0.994167	-0.055420	1.027336	0.000000
13	0.412998	-0.551160	-0.028449	0.760162	0.089015	-0.053393	-0.994704	-0.068910	1.033881	0.000000
14	0.372480	-0.551831	-0.031965	0.719491	0.084184	-0.048604	-0.995264	-0.082801	1.040577	0.000000
15	0.330775	-0.552084	-0.035368	0.677645	0.078955	-0.045584	-0.995835	-0.094855	1.046353	0.000000
16	0.288265	-0.552152	-0.038625	0.635011	0.073220	-0.042714	-0.996419	-0.108206	1.052714	0.000000
17	0.245352	-0.552002	-0.041647	0.591991	0.066732	-0.038528	-0.997027	-0.120501	1.058637	0.000000
18	0.202408	-0.551610	-0.044392	0.548958	0.059559	-0.034386	-0.997632	-0.133847	1.064823	0.000000
19	0.159796	-0.550973	-0.046791	0.506274	0.051396	-0.029674	-0.998237	-0.147055	1.071007	0.000000
20	0.117878	-0.550086	-0.048792	0.464299	0.042073	-0.024491	-0.998819	-0.160882	1.077443	0.000000
21	0.076978	-0.548960	-0.050333	0.423354	0.031616	-0.018254	-0.999333	-0.173846	1.083442	0.000000
22	0.037393	-0.547617	-0.051390	0.383733	0.019877	-0.011476	-0.999771	-0.187685	1.089810	0.000000
23	0.000609	-0.546080	-0.051918	0.345695	0.006559	-0.003787	-0.999971	-0.200706	1.095767	0.000000
24	-0.036764	-0.544390	-0.051901	0.309502	-0.008362	0.004828	-0.999953	-0.213263	1.101482	0.000000
25	-0.070895	-0.542609	-0.051329	0.275319	-0.025056	0.014466	-0.999581	-0.224534	1.106587	0.000000
26	-0.102812	-0.540737	-0.050212	0.243330	-0.043587	0.025165	-0.999733	-0.234217	1.110953	0.000000
27	-0.132391	-0.538930	-0.048575	0.213648	-0.064045	0.036877	-0.999262	-0.241856	1.114386	0.000000
28	-0.159516	-0.537136	-0.046462	0.186382	-0.086941	0.050196	-0.998948	-0.247852	1.117075	0.000000
29	-0.184136	-0.535439	-0.044398	0.161572	-0.112625	0.065124	-0.998508	-0.249872	1.117977	0.000000
30	-0.206212	-0.533891	-0.040980	0.139249	-0.141537	0.081717	-0.988554	-0.248230	1.117242	0.000000
31	-0.225777	-0.532532	-0.037733	0.119369	-0.174468	0.100729	-0.979497	-0.240632	1.113836	0.000000
32	-0.242854	-0.531401	-0.034243	0.101903	-0.212526	0.122702	-0.969421	-0.225723	1.107124	0.000000
33	-0.257550	-0.530527	-0.030571	0.088750	-0.256538	0.148112	-0.958119	-0.209119	1.095811	0.000000
34	-0.269929	-0.529936	-0.026803	0.073777	-0.306903	0.178345	-0.934223	-0.156751	1.076453	0.000000

SUBROUTINE STREAMD OUTPUT FOR SLICE: 3

Figure 26. - Continued.

35	-0.280186	-0.529654	-0.022984	0.062028	-0.371043	0.214222	-0.903569	-0.094411	1.046141	0.000000
36	-0.280487	-0.529708	-0.019208	0.053709	-0.444606	0.256690	-0.858157	-0.016035	1.000802	0.000000
37	-0.295050	-0.530128	-0.015519	0.046169	-0.530856	0.306490	-0.790099	0.129062	0.933241	0.000000
38	-0.300129	-0.530975	-0.011986	0.036047	-0.624244	0.360407	-0.693128	0.292556	0.841097	0.000000
39	-0.304042	-0.532349	-0.008695	0.036330	-0.716152	0.413470	-0.562288	0.466603	0.730340	0.000000
40	-0.307233	-0.533568	-0.005716	0.029733	-0.793461	0.458105	-0.400699	0.617588	0.618394	0.000000
41	-0.310255	-0.538105	-0.003135	0.024413	-0.841699	0.485955	-0.235352	0.712148	0.536518	0.000000
42	-0.314661	-0.545097	-0.001117	0.015905	-0.861861	0.497595	-0.097951	0.748794	0.501205	0.000000
43	-0.322432	-0.558815	0.000000	0.000000	-0.866026	0.500000	0.000000	0.758066	0.491888	0.000000
44	-0.320114	-0.554541	0.001117	-0.005085	-0.861861	0.497595	0.097951	0.713368	0.535380	0.000000
45	-0.314522	-0.545201	0.003135	-0.016243	-0.841699	0.485955	0.235352	0.753344	0.501205	0.000000
46	-0.310888	-0.540899	0.005716	-0.022339	-0.793461	0.458105	0.400699	0.617288	0.618394	0.000000
47	-0.307412	-0.538186	0.008695	-0.027661	-0.716152	0.413470	0.562288	0.468377	0.729125	0.000000
48	-0.303356	-0.535566	0.011986	-0.033129	-0.624244	0.360407	0.693128	0.294643	0.839855	0.000000
49	-0.535583	0.015519	0.011986	-0.039458	-0.530512	0.306291	0.790407	0.131308	0.932036	0.000000
50	-0.535048	0.019200	0.012005	-0.047059	-0.444557	0.256665	0.858191	0.001314	0.999343	0.000000
51	-0.298199	-0.535048	0.019200	-0.056213	-0.371091	0.214249	0.903542	-0.092305	1.075059	0.000000
52	-0.283236	-0.535179	0.022984	-0.067179	-0.308939	0.173777	0.934198	-0.155730	1.075059	0.000000
53	-0.260548	-0.535738	0.030571	-0.080160	-0.256906	0.148324	0.954987	-0.197463	1.094287	0.000000
54	-0.245862	-0.536592	0.034243	-0.095323	-0.212475	0.122672	0.969436	-0.224099	1.106390	0.000000
55	-0.228768	-0.537712	0.037733	-0.112005	-0.174248	0.100613	0.979545	-0.238917	1.113066	0.000000
56	-0.209203	-0.539054	0.040972	-0.132682	-0.141528	0.081711	0.985556	-0.245674	1.116098	0.000000
57	-0.182497	-0.540598	0.043908	-0.150199	-0.112786	0.065117	0.991483	-0.248280	1.116264	0.000000
58	-0.162797	-0.542284	0.046462	-0.179825	-0.086961	0.050207	0.994946	-0.246274	1.116366	0.000000
59	-0.135373	-0.544077	0.048575	-0.207090	-0.064045	0.036977	0.997262	-0.240271	1.113675	0.000000
60	-0.105796	-0.545919	0.050212	-0.236770	-0.043587	0.025165	0.998733	-0.232688	1.110265	0.000000
61	-0.073869	-0.547742	0.051329	-0.268768	-0.025056	0.014666	0.999581	-0.219197	1.105937	0.000000
62	-0.039735	-0.549520	0.051901	-0.302953	-0.008362	0.004928	0.999771	-0.199456	1.095197	0.000000
63	-0.034445	-0.551184	0.051918	-0.339161	-0.006561	-0.003788	0.999744	-0.186347	1.089195	0.000000
64	0.074067	-0.553984	0.050342	-0.372205	-0.019764	-0.011411	0.999334	-0.173551	1.083305	0.000000
65	0.114987	-0.555075	0.048792	-0.416862	-0.031610	-0.018250	0.998013	-0.159813	1.076946	0.000000
66	0.156923	-0.555932	0.046791	-0.457826	-0.042181	-0.024353	0.998037	-0.146292	1.070650	0.000000
67	0.199551	-0.556541	0.044647	-0.499818	-0.051396	-0.029674	0.997632	-0.135220	1.064528	0.000000
68	0.242520	-0.556888	0.041647	-0.542518	-0.059559	-0.034386	0.997027	-0.119996	1.058298	0.000000
69	0.285455	-0.557001	0.038625	-0.585577	-0.066732	-0.038528	0.996419	-0.107817	1.052529	0.000000
70	0.327978	-0.556910	0.035368	-0.628618	-0.073220	-0.042274	0.995277	-0.094567	1.046216	0.000000
71	0.369699	-0.556631	0.031965	-0.671265	-0.078955	-0.045584	0.995277	-0.082470	1.040418	0.000000
72	0.410248	-0.556165	0.028458	-0.713126	-0.084074	-0.048540	0.994703	-0.069518	1.034175	0.000000
73	0.449236	-0.555545	0.024907	-0.753829	-0.089020	-0.051396	0.994153	-0.053704	1.027316	0.000000
74	0.486265	-0.554871	0.021382	-0.792983	-0.093514	-0.053928	0.993080	-0.040627	1.020111	0.000000
75	0.486265	-0.554871	0.017935	-0.830186	-0.097737	-0.056428	0.993080	-0.023704	1.011783	0.000000
76	0.521024	-0.554060	0.014636	-0.865124	-0.010703	-0.058718	0.992561	-0.005318	1.002656	0.000000
77	0.553141	-0.553204	0.011535	-0.897422	-0.0105440	-0.060876	0.992044	0.015863	0.997037	0.000000
78	0.582337	-0.552304	0.008695	-0.926796	0.0109024	-0.062945	0.991562	0.039685	0.979957	0.000000
79	0.608378	-0.551263	0.006175	-0.953012	0.0112265	-0.064816	0.991155	0.066504	0.966176	0.000000
80	0.630850	-0.550360	0.004027	-0.975643	0.0115187	-0.066503	0.991155	0.097164	0.950177	0.000000
81	0.649653	-0.549418	0.002295	-0.994592	0.0117890	-0.068064	0.990691	0.097164	0.930619	0.000000
82	0.664643	-0.548380	0.002295	-1.009171	0.0119901	-0.069225	0.990369	0.133948	0.902637	0.000000
83	0.675456	-0.547630	0.001031	-1.020659	0.0121166	-0.069955	0.990164	0.178734	0.862537	0.000000
84	0.682041	-0.547084	0.000260	-1.029682	0.0141436	-0.070526	0.990002	0.217552	0.884561	0.000000
85	0.684222	-0.546944	0.000000	-1.037925	0.000000	0.000000	0.997481	0.220215	0.883054	0.000000
86	0.692634	-0.546232	0.000000	-1.050493	0.000000	0.000000	1.000000	0.143550	0.901224	0.000000
87	0.705168	-0.545307	0.000000	-1.061515	0.000000	0.000000	1.000000	0.143550	0.925470	0.000000
88	0.736144	-0.543615	0.000000	-1.081515	0.000000	0.000000	1.000000	-0.098200	0.949632	0.000000

Figure 26. - Continued.

*** SUBROUTINE STREMSD COMPLETE ***
 CPU TIME = 966.413

TRAJECTORY DATA ARE WRITTEN ON UNIT 10 FOR PLOTTING

WATER DROP DIAMETER = 2.00000E+01 MICROMETERS
 PARTICLE SETTLING SPEED = 1.93333E-04 M/SEC

*** SUBROUTINE CONFAC BEGINS ***

*** SUBROUTINE CONFAC RUNS COMPLETE, CPU TIME = 1003.258 SECONDS ***

***** OUTPUT FROM SUBROUTINE CONFAC FOR ICEC= 3

XSCI	YSCI	ZSCI	XSCF	YSCF	ZSCF
-20.00000	-0.54883	0.04462	-0.31800	-0.54989	0.05006
-20.00000	-0.54851	-0.05417	-0.31800	-0.54992	-0.06007

*** SUBROUTINE IMPLIM BEGINS ***

*** SUBROUTINE IMPLIM RUNS COMPLETE, CPU TIME = 1178.084 SECONDS ***

***** OUTPUT FROM SUBROUTINE IMPLIM FOR ICEC= 3

XTIP	YTIP	ZTIP	XTIF	YTIF	ZTIF
-20.00000	-0.54874	0.01713	-0.26688	-0.54555	0.03037
-20.00000	-0.54863	-0.01702	-0.26721	-0.54544	-0.03025

SUBROUTINE ARYTRJ INPUT FOR SLICE: 3

ROW (NBRC) COLUMN (NBCC) X(NBRC,NBCC) Y(NBRC,NBCC) Z(NBRC,NBCC)

Figure 26. - Continued.

1	1	-20.000000	0.017127
2	1	-0.548742	0.015329
3	1	-0.548736	0.013532
4	1	-0.548730	0.011734
5	1	-0.548724	0.009937
6	1	-0.548718	0.008140
7	1	-0.548712	0.006342
8	1	-0.548707	0.004545
9	1	-0.548701	0.002747
10	1	-0.548695	0.000950
11	1	-0.548689	-0.000847
12	1	-0.548683	-0.002645
13	1	-0.548677	-0.004442
14	1	-0.548671	-0.006240
15	1	-0.548665	-0.008037
16	1	-0.548660	-0.009835
17	1	-0.548654	-0.011632
18	1	-0.548648	-0.013429
19	1	-0.548642	-0.015227
20	1	-0.548636	-0.017024

*** SUBROUTINE ARYTRJ BEGINS ***

*** SUBROUTINE ARYTRJ RUNS COMPLETE, CPU TIME = 1337.498 SECONDS ***

***** OUTPUT FROM SUBROUTINE ARYTRJ FOR ICEC= 3

XBLI	YBLI	ZBLI	XBLF	YBLF	ZBLF	TNORMX	TNORMY	TNORMZ
-20.00000	-0.54874	0.01713	-0.26688	-0.54555	0.03037	-0.96933	-0.02918	-0.24402
-20.00000	-0.54874	0.01533	-0.28934	-0.54624	0.02314	-0.97217	-0.06317	-0.22560
-20.00000	-0.54873	0.01353	-0.29803	-0.54658	0.01929	-0.97513	-0.08147	-0.20610
-20.00000	-0.54872	0.01173	-0.30360	-0.54682	0.01615	-0.97797	-0.09585	-0.18546
-20.00000	-0.54872	0.00994	-0.30763	-0.54701	0.01334	-0.98082	-0.10806	-0.16223
-20.00000	-0.54871	0.00814	-0.31069	-0.54716	0.01071	-0.98359	-0.11860	-0.13597
-20.00000	-0.54871	0.00634	-0.31298	-0.54728	0.00821	-0.98614	-0.12705	-0.10667
-20.00000	-0.54870	0.00454	-0.31457	-0.54737	0.00581	-0.98823	-0.13248	-0.07655
-20.00000	-0.54869	0.00275	-0.31550	-0.54742	0.00347	-0.99056	-0.13627	-0.04687
-20.00000	-0.54869	0.00095	-0.31601	-0.54744	0.00116	-0.99040	-0.13733	-0.01587
-20.00000	-0.54868	-0.00085	-0.31601	-0.54744	-0.00113	-0.99040	-0.13735	0.01542
-20.00000	-0.54868	-0.00264	-0.31550	-0.54740	-0.00344	-0.98955	-0.13650	0.04645
-20.00000	-0.54867	-0.00444	-0.31457	-0.54734	-0.00578	-0.98824	-0.13263	0.07614
-20.00000	-0.54867	-0.00624	-0.31297	-0.54724	-0.00818	-0.98617	-0.12718	0.10631
-20.00000	-0.54866	-0.00804	-0.31069	-0.54711	-0.01067	-0.98362	-0.11875	0.13559
-20.00000	-0.54866	-0.00983	-0.30764	-0.54694	-0.01330	-0.98086	-0.10824	0.16186
-20.00000	-0.54865	-0.01163	-0.30363	-0.54674	-0.01611	-0.97800	-0.09611	0.18516
-20.00000	-0.54864	-0.01343	-0.29813	-0.54650	-0.01923	-0.97513	-0.08188	0.20595
-20.00000	-0.54864	-0.01523	-0.28946	-0.54614	-0.02307	-0.97227	-0.06348	0.22506
-20.00000	-0.54863	-0.01702	-0.26721	-0.54544	-0.03025	-0.96935	-0.02966	0.24390

Figure 26. - Continued.

SUBROUTINE BETAC OUTPUT FOR SLICE: 3

ROW (N1L)	COLUMN (NJL)	X(NBRC,NBCC)	Y(NBRC,NBCC)	Z(NBRC,NBCC)	BETA(NBRC,NBCC)	BNORMX	BNORMY	BNORMZ
1	1	-0.27811	-0.54589	0.02676	0.07621	-0.97093	-0.04618	-0.23481
2	1	-0.29368	-0.54641	0.02121	0.10736	-0.97374	-0.07232	-0.21585
3	1	-0.30081	-0.54670	0.01772	0.27552	-0.97663	-0.08866	-0.19578
4	1	-0.30561	-0.54691	0.01474	0.35252	-0.97948	-0.10195	-0.17385
5	1	-0.30916	-0.54708	0.01202	0.42349	-0.98230	-0.11333	-0.14910
6	1	-0.31183	-0.54722	0.00946	0.49396	-0.98498	-0.12283	-0.12132
7	1	-0.31377	-0.54733	0.00701	0.56689	-0.98730	-0.12977	-0.09161
8	1	-0.31503	-0.54739	0.00464	0.63135	-0.98900	-0.13438	-0.06171
9	1	-0.31576	-0.54743	0.00232	0.66334	-0.99010	-0.13680	-0.03137
10	1	-0.31601	-0.54744	0.00002	0.67774	-0.99052	-0.13734	-0.00023
11	1	-0.31576	-0.54742	-0.00029	0.66365	-0.99010	-0.13695	0.03094
12	1	-0.31504	-0.54737	-0.00461	0.63216	-0.98900	-0.13457	0.06130
13	1	-0.31377	-0.54729	-0.00698	0.56693	-0.98732	-0.12991	0.09122
14	1	-0.31183	-0.54717	-0.00942	0.49514	-0.98501	-0.12296	0.12095
15	1	-0.30916	-0.54702	-0.01199	0.42476	-0.98234	-0.11349	0.14872
16	1	-0.30563	-0.54684	-0.01470	0.35423	-0.97951	-0.10218	0.17351
17	1	-0.30088	-0.54662	-0.01717	0.27826	-0.97664	-0.08900	0.19555
18	1	-0.29380	-0.54632	-0.02115	0.18825	-0.97379	-0.07268	0.21551
19	1	-0.27834	-0.54579	-0.02666	0.07691	-0.97099	-0.04657	0.23448

*** SUBROUTINE BETAC COMPLETE ***

CPU TIME = 1337.589

SUBROUTINE BSTREM OUTPUT FOR SLICE: 3

POINT	XSTRM	YSTRM	ZSTRM	SSTRM	XNSTRM	YNSTRM	ZNSTRM	CPSTRM	VSTRM	BSTRM
1	0.68688	-0.54234	0.00000	1.03573	0.12256	-0.07076	-0.98993	0.22142	0.88237	0.00000
2	0.68465	-0.54257	-0.00026	1.03347	0.12215	-0.07053	-0.99000	0.21844	0.88406	0.00000
3	0.67801	-0.54321	-0.00103	1.02876	0.12117	-0.06996	-0.99016	0.21925	0.90595	0.00000
4	0.66719	-0.54397	-0.00230	1.01583	0.11990	-0.06922	-0.99037	0.23449	0.93033	0.00000
5	0.65225	-0.54491	-0.00403	1.00077	0.11792	-0.06808	-0.99069	0.09776	0.94986	0.00000
6	0.63348	-0.54582	-0.00618	0.98185	0.11519	-0.06651	-0.99111	0.06703	0.96590	0.00000
7	0.61094	-0.54682	-0.00870	0.95915	0.11226	-0.06481	-0.99156	0.04033	0.97963	0.00000
8	0.58504	-0.54765	-0.01154	0.93308	0.10905	-0.06296	-0.99204	0.01642	0.99176	0.00000
9	0.55583	-0.54857	-0.01464	0.90369	0.10544	-0.06088	-0.99256	-0.00480	1.00240	0.00000
10	0.52370	-0.54945	-0.01794	0.87138	0.10170	-0.05872	-0.99308	-0.02330	1.01158	0.00000
11	0.48896	-0.55022	-0.02138	0.83646	0.09774	-0.05643	-0.99361	-0.04038	1.01999	0.00000
12	0.45195	-0.55085	-0.02491	0.79928	0.09340	-0.05392	-0.99417	-0.05542	1.02734	0.00000
13	0.41300	-0.55142	-0.02845	0.76016	0.08902	-0.05139	-0.99470	-0.06891	1.03388	0.00000
14	0.37248	-0.55183	-0.03197	0.71949	0.08418	-0.04860	-0.99526	-0.08280	1.04058	0.00000
15	0.33077	-0.55208	-0.03537	0.67765	0.07895	-0.04558	-0.99584	-0.09486	1.04635	0.00000
16	0.28826	-0.55215	-0.03863	0.63501	0.07322	-0.04227	-0.99642	-0.10821	1.05271	0.00000

Figure 26. - Continued.

17	0.24535	-0.55200	-0.04165	0.59199	0.06673	-0.03853	-0.99703	-0.12050	1.05854	0.00000
18	0.20241	-0.55161	-0.04439	0.54896	0.05956	-0.03439	-0.99763	-0.13385	1.06482	0.00000
19	0.15980	-0.55097	-0.04679	0.50627	0.05140	-0.02967	-0.99824	-0.14706	1.07101	0.00000
20	0.11788	-0.55009	-0.04879	0.46430	0.04207	-0.02429	-0.99882	-0.16088	1.07744	0.00000
21	0.07698	-0.54896	-0.05033	0.42335	0.03162	-0.01825	-0.99933	-0.17385	1.08344	0.00000
22	0.03739	-0.54762	-0.05139	0.38373	0.01988	-0.01148	-0.99974	-0.18769	1.08981	0.00000
23	0.00061	-0.54608	-0.05192	0.34570	0.00656	-0.00379	-0.99997	-0.20071	1.09577	0.00000
24	-0.03676	-0.54439	-0.05190	0.30950	-0.00836	-0.00483	-0.99995	-0.21326	1.10148	0.00000
25	-0.07090	-0.54261	-0.05133	0.27532	-0.02506	0.01447	-0.99950	-0.22453	1.10659	0.00000
26	-0.10281	-0.54077	-0.05021	0.24333	-0.04359	0.02517	-0.99873	-0.23422	1.11095	0.00000
27	-0.13239	-0.53893	-0.04858	0.21365	-0.06405	0.03698	-0.99726	-0.24285	1.11439	0.00000
28	-0.15952	-0.53714	-0.04664	0.18638	-0.08694	0.05020	-0.99495	-0.24785	1.11707	0.00000
29	-0.18414	-0.53544	-0.04391	0.16157	-0.11262	0.06502	-0.99151	-0.24987	1.11798	0.00000
30	-0.20621	-0.53389	-0.04098	0.13925	-0.14154	0.08172	-0.98555	-0.24823	1.11724	0.00000
31	-0.22578	-0.53253	-0.03773	0.11937	-0.17447	0.10073	-0.97950	-0.24063	1.11384	0.00000
32	-0.24285	-0.53140	-0.03424	0.10190	-0.21253	0.12270	-0.96942	-0.22572	1.10712	0.00000
33	-0.25753	-0.53053	-0.03057	0.08675	-0.25654	0.14811	-0.95512	-0.19907	1.09502	0.00000
34	-0.26993	-0.52994	-0.02680	0.07378	-0.30890	0.17835	-0.93422	-0.15875	1.07645	0.08114
35	-0.28019	-0.52965	-0.02298	0.06283	-0.37104	0.21422	-0.90357	-0.09441	1.04614	0.15779
36	-0.28849	-0.52971	-0.01921	0.05371	-0.44461	0.25669	-0.85816	-0.00161	1.00080	0.24265
37	-0.29505	-0.53013	-0.01552	0.04617	-0.53086	0.30649	-0.79010	0.12906	0.93324	0.33694
38	-0.30013	-0.53098	-0.01199	0.03992	-0.62424	0.36041	-0.69313	0.29256	0.84110	0.42746
39	-0.30404	-0.53235	-0.00870	0.03463	-0.71615	0.41347	-0.56229	0.46560	0.73034	0.51901
40	-0.30723	-0.53457	-0.00572	0.02973	-0.81170	0.45810	-0.40070	0.61759	0.61839	0.60304
41	-0.31025	-0.53810	-0.00314	0.02441	-0.84170	0.48595	-0.23535	0.71215	0.53652	0.65250
42	-0.31466	-0.54510	-0.00112	0.01591	-0.86186	0.49760	-0.09795	0.74879	0.50121	0.67087
43	-0.32263	-0.55882	0.00000	0.00000	-0.86603	0.50000	0.00000	0.75805	0.49189	0.67787
44	-0.32811	-0.57454	0.00112	0.00008	-0.80186	0.49760	0.09795	0.75999	0.49001	0.67092
45	-0.33135	-0.58450	0.00314	0.01624	-0.84170	0.48595	0.23535	0.71337	0.53538	0.65247
46	-0.33494	-0.59490	0.00572	0.02234	-0.79346	0.45810	0.40070	0.61896	0.61729	0.60348
47	-0.33819	-0.59819	0.00870	0.02766	-0.71615	0.41347	0.56229	0.46838	0.72912	0.51920
48	-0.34336	-0.59657	0.01199	0.03313	-0.62424	0.36041	0.69313	0.29464	0.83986	0.42722
49	-0.34920	-0.59558	0.01552	0.03946	-0.55051	0.30629	0.79041	0.13131	0.93204	0.33615
50	-0.35505	-0.59420	0.01920	0.04706	-0.44456	0.25666	0.85819	0.00131	0.99934	0.24228
51	-0.36118	-0.59298	0.02298	0.05621	-0.37109	0.21425	0.90354	0.09230	0.99934	0.15840
52	-0.36718	-0.59180	0.02680	0.06718	-0.30896	0.17838	0.93420	0.15573	1.04513	0.08250
53	-0.37357	-0.59074	0.03057	0.08016	-0.25691	0.14832	0.95499	0.19746	1.07505	0.00000
54	-0.38059	-0.58979	0.03424	0.09532	-0.21247	0.12267	0.96944	0.22410	1.09429	0.00000
55	-0.38827	-0.58895	0.03773	0.11281	-0.17427	0.10061	0.97954	0.23892	1.10639	0.00000
56	-0.39660	-0.58828	0.04391	0.13268	-0.14153	0.08171	0.98656	0.24567	1.11307	0.00000
57	-0.40558	-0.58777	0.04964	0.15502	-0.11279	0.06512	0.99148	0.24828	1.11726	0.00000
58	-0.41518	-0.58744	0.05466	0.17982	-0.08596	0.05021	0.99495	0.24627	1.11137	0.00000
59	-0.42528	-0.58720	0.06046	0.20709	-0.06405	0.03698	0.99726	0.24027	1.11367	0.00000
60	-0.43592	-0.58700	0.06676	0.23677	-0.04359	0.02517	0.99873	0.23269	1.11026	0.00000
61	-0.44714	-0.58690	0.07339	0.26877	-0.02506	0.01447	0.99958	0.22310	1.10594	0.00000
62	-0.45899	-0.58690	0.08016	0.30295	-0.00836	0.00483	0.99995	0.21192	1.10087	0.00000
63	-0.47118	-0.58699	0.08712	0.33916	0.00256	-0.00379	0.99974	0.19946	1.09520	0.00000
64	-0.48444	-0.58729	0.09466	0.37720	0.01976	-0.01141	0.99974	0.18635	1.08920	0.00000
65	-0.49879	-0.58777	0.10281	0.41686	0.03161	0.01825	0.99933	0.17355	1.08351	0.00000
66	-0.51419	-0.58849	0.11199	0.45783	0.04218	-0.02435	0.99881	0.15981	1.07695	0.00000
67	-0.53069	-0.58939	0.12267	0.49982	0.05140	-0.02967	0.99824	0.14629	1.07065	0.00000
68	-0.54834	-0.59053	0.13424	0.54252	0.05956	-0.03439	0.99763	0.13322	1.06453	0.00000
69	-0.56714	-0.59190	0.14714	0.58558	0.06673	-0.03853	0.99703	0.12000	1.05850	0.00000
70	-0.58700	-0.59357	0.16118	0.62862	0.07332	-0.04227	0.99642	0.10782	1.05253	0.00000
71	-0.60712	-0.59558	0.17627	0.67127	0.07895	-0.04558	0.99584	0.09457	1.04622	0.00000

Figure 26. - Continued.

POINT	XSTSV	YSTSV	ZSTSV	BETA	DICE	XNSTRM	YNSTRM	ZNSTRM	XNTRJ	YNTRJ	ZNTRJ
72	0.36970	-0.55663	0.03197	-0.71313	0.08407	-0.04854	0.99528	-0.08247	1.06042	0.00000	0.00000
73	0.41025	-0.55617	0.02846	-0.75383	0.08902	-0.05140	0.99470	-0.06952	1.03417	0.00000	0.00000
74	0.44924	-0.55555	0.02491	-0.79298	0.09351	-0.05399	0.99415	-0.05338	1.02732	0.00000	0.00000
75	0.48427	-0.55487	0.02138	-0.83019	0.09774	-0.05643	0.99361	-0.04063	1.02011	0.00000	0.00000
76	0.52102	-0.55406	0.01794	-0.86512	0.10170	-0.05872	0.99308	-0.02370	1.01178	0.00000	0.00000
77	0.55314	-0.55321	0.01464	-0.89742	0.10544	-0.06088	0.99256	-0.00532	1.00266	0.00000	0.00000
78	0.58234	-0.55230	0.01154	-0.92680	0.10902	-0.06294	0.99204	0.01586	0.99204	0.00000	0.00000
79	0.60838	-0.55126	0.00870	-0.95301	0.11227	-0.06482	0.99156	0.03968	0.97996	0.00000	0.00000
80	0.63005	-0.55036	0.00618	-0.97564	0.11519	-0.06650	0.99112	0.06450	0.96618	0.00000	0.00000
81	0.64965	-0.54942	0.00403	-0.99449	0.11789	-0.06806	0.99069	0.09176	0.95018	0.00000	0.00000
82	0.66464	-0.54838	0.00230	-1.00972	0.11990	-0.06922	0.99037	0.13395	0.93070	0.00000	0.00000
83	0.67546	-0.54763	0.00103	-1.02063	0.12117	-0.06996	0.99016	0.17873	0.90624	0.00000	0.00000
84	0.68204	-0.54708	0.00026	-1.02728	0.12155	-0.07053	0.99000	0.21755	0.88456	0.00000	0.00000
85	0.68422	-0.54694	0.00000	-1.02948	0.06144	-0.03547	0.99748	0.22021	0.83305	0.00000	0.00000
86	0.69263	-0.54623	0.00000	-1.03792	0.00000	0.00000	1.00000	0.18780	0.90122	0.00000	0.00000
87	0.70517	-0.54531	0.00000	-1.05049	0.00000	0.00000	1.00000	0.14350	0.92547	0.00000	0.00000
88	0.73614	-0.54361	0.00000	-1.08152	0.00000	0.00000	1.00000	0.09820	0.94963	0.00000	0.00000

*** SUBROUTINE BSTREM COMPLETE ***

CPU TIME = 1337.698

SUBROUTINE LEWICE2D GEOMETRY OUTPUT FOR SLICE: 1 TIME= 120.000

Figure 26. - Continued.

POINT	XSTV	YSTV	ZSTV	SSTRM	BETA	DDICE	VEDGE	HTC	PEDGE	TEDGE
81	0.798394	-0.014248	0.021382	0.000000	0.000000	0.097737	-0.056428	0.993611	0.000000	0.000000
82	0.832724	-0.014179	0.017935	0.000000	0.000000	0.101703	-0.058718	0.993080	0.000000	0.000000
83	0.864679	-0.013962	0.014636	0.000000	0.000000	0.105440	-0.060876	0.992561	0.000000	0.000000
84	0.893488	-0.013374	0.011535	0.000000	0.000000	0.109024	-0.062945	0.992044	0.000000	0.000000
85	0.919233	-0.012847	0.008695	0.000000	0.000000	0.112265	-0.064816	0.991562	0.000000	0.000000
86	0.941448	-0.012387	0.006175	0.000000	0.000000	0.115187	-0.066503	0.991115	0.000000	0.000000
87	0.960124	-0.011666	0.004027	0.000000	0.000000	0.117890	-0.068064	0.990691	0.000000	0.000000
88	0.974933	-0.010942	0.002295	0.000000	0.000000	0.119901	-0.069225	0.990369	0.000000	0.000000
89	0.985735	-0.010211	0.001031	0.000000	0.000000	0.121166	-0.069955	0.990164	0.000000	0.000000
90	0.992325	-0.009657	0.000260	0.000000	0.000000	0.122154	-0.070526	0.990002	0.000000	0.000000
91	0.994487	-0.009549	0.000000	0.000000	0.000000	0.122154	-0.070526	0.990002	0.000000	0.000000
92	1.002866	-0.008892	0.000000	0.000000	0.000000	0.000000	0.000000	1.000000	0.000000	0.000000
93	1.015324	-0.008099	0.000000	0.000000	0.000000	0.000000	0.000000	1.000000	0.000000	0.000000
94	1.046131	-0.006701	0.000000	0.000000	0.000000	0.000000	0.000000	1.000000	0.000000	0.000000

SUBROUTINE LEWICE2D HEAT TRANSFER OUTPUT FOR SLICE: 1 TIME= 120.000

POINT	XSTV	YSTV	ZSTV	SSTRM	BETA	DDICE	VEDGE	HTC	PEDGE	TEDGE
1	0.998040	-0.003394	0.000000	-0.388100	0.000000	0.000000	57.519264	0.000000	90569.864	267.587327
2	0.995806	-0.003627	-0.000260	-0.386489	0.000000	0.000000	58.835213	314.98831	90479.654	267.511150
3	0.989205	-0.004200	-0.001031	-0.383286	0.000000	0.000000	60.678822	334.54978	90349.953	267.401530
4	0.978420	-0.004902	-0.002295	-0.378522	0.000000	0.000000	62.176600	351.26225	90241.737	267.309983
5	0.963586	-0.005671	-0.004027	-0.372247	0.000000	0.000000	63.389428	365.56449	90152.246	267.234218
6	0.944966	-0.006311	-0.006175	-0.364519	0.000000	0.000000	64.403464	378.28056	90076.146	267.169774
7	0.922802	-0.007012	-0.008695	-0.355415	0.000000	0.000000	65.295196	390.22221	90008.266	267.112277
8	0.896932	-0.007426	-0.011535	-0.345028	0.000000	0.000000	66.100754	401.80102	89946.175	267.059547
9	0.866210	-0.007887	-0.014636	-0.333455	0.000000	0.000000	67.507970	413.11174	89889.528	267.011481
10	0.836210	-0.008158	-0.017935	-0.320811	0.000000	0.000000	68.155554	424.57024	89835.958	266.966002
11	0.801977	-0.008232	-0.021382	-0.307214	0.000000	0.000000	68.759595	436.39209	89784.490	266.922299
12	0.765263	-0.008188	-0.024907	-0.292792	0.000000	0.000000	69.364436	448.49642	89736.060	266.881154
13	0.726785	-0.007925	-0.028449	-0.277681	0.000000	0.000000	69.954487	459.39723	89687.151	266.839586
14	0.686788	-0.007435	-0.031965	-0.262018	0.000000	0.000000	70.541454	470.37677	89639.053	266.798693
15	0.645422	-0.006751	-0.035368	-0.245945	0.000000	0.000000	71.136476	480.78355	89590.817	266.757665
16	0.603659	-0.005873	-0.038625	-0.229606	0.000000	0.000000	71.728530	490.37677	89541.526	266.715724
17	0.561268	-0.004819	-0.041647	-0.213143	0.000000	0.000000	72.334037	500.30563	89492.085	266.673639
18	0.518820	-0.003568	-0.044392	-0.196694	0.000000	0.000000	72.940611	509.30563	89441.126	266.630245
19	0.476652	-0.002161	-0.046791	-0.180395	0.000000	0.000000	73.531290	516.85013	89389.665	266.586404
20	0.435133	-0.000585	-0.048792	-0.164380	0.000000	0.000000	74.110357	524.65450	89339.160	266.543361
21	0.393677	0.001137	-0.050333	-0.148766	0.000000	0.000000	74.677616	532.46714	89289.272	266.500327
22	0.353263	0.002949	-0.051390	-0.133666	0.000000	0.000000	75.205004	540.46714	89240.041	266.458836
23	0.317468	0.004846	-0.051918	-0.119185	0.000000	0.000000	75.682233	548.45948	89193.952	266.419510
24	0.281455	0.006782	-0.051901	-0.105414	0.000000	0.000000	76.117845	556.33093	89151.981	266.383385
25	0.247421	0.008731	-0.051329	-0.092428	0.000000	0.000000	76.507504	564.45948	89116.595	266.353372
26	0.215539	0.010632	-0.050212	-0.080294	0.000000	0.000000	76.8445	572.46714	89088.618	266.329378
27	0.185941	0.012438	-0.048575	-0.069062	0.000000	0.000000	77.136476	580.78355	89067.204	266.311285
28	0.158763	0.014138	-0.046462	-0.058770	0.000000	0.000000	77.37624	589.39723	89055.059	266.300909
29	0.134058	0.015689	-0.043908	-0.049439	0.000000	0.000000	77.575761	597.46714	89054.863	266.300742
30	0.111872	0.017047	-0.040980	-0.041074	0.000000	0.000000	77.73559	605.8612	89068.888	266.312724
31	0.092190	0.018203	-0.037733	-0.033669	0.000000	0.000000	77.8445	614.1115	89101.795	266.340832
32	0.074987	0.019116	-0.034243	-0.027204	0.000000	0.000000	77.9095	622.46714	89161.584	266.391712
33	0.060187	0.019775	-0.030571	-0.021637	0.000000	0.000000	77.92451	630.78355	89255.665	266.472164
34	0.047416	0.020315	-0.027580	-0.016918	0.000000	0.001662	77.802173	639.32677	89401.446	266.566492
35	0.036528	0.020710	-0.025032	-0.012982	0.000000	0.002809	77.203916	648.45948	89618.602	266.781300

Figure 26. - Continued.

36	0.027476	0.020869	-0.022241	-0.009749	0.274328	0.004101	66.362951	1680.20732	89925.808	267.042268
37	0.019894	0.020833	-0.019443	-0.007128	0.365645	0.005466	60.960225	1711.88823	90329.815	267.384501
38	0.013526	0.020537	-0.014500	-0.005021	0.453328	0.006777	54.146725	1660.15407	90792.013	267.774688
39	0.008110	0.019855	-0.013307	-0.003335	0.537186	0.008030	46.696047	1536.37000	91236.384	268.148490
40	0.003428	0.018419	-0.009782	-0.001988	0.602115	0.009001	40.153544	1420.92863	91573.474	268.431182
41	0.001237	0.016772	-0.007921	-0.000941	0.692115	0.009501	36.123400	1420.92863	91573.474	268.431182
42	0.000953	0.015125	-0.006060	-0.000246	0.635601	0.009501	34.712099	1447.33885	91756.212	268.584119
43	0.003401	0.011903	-0.004386	0.000246	0.635601	0.009501	34.712099	1447.33885	91756.212	268.584119
44	0.005869	0.006681	-0.002712	0.000941	0.677920	0.009685	36.113994	1447.33885	91815.696	268.633856
45	0.008351	0.004616	-0.001593	0.001988	0.677920	0.009685	40.176945	1447.33885	91815.696	268.633856
46	0.010854	0.000551	0.000475	0.003335	0.647925	0.009685	46.814866	1446.89553	91815.693	268.633853
47	0.010795	0.000517	0.000554	0.005021	0.647925	0.009685	54.327061	1446.89553	91815.693	268.633853
48	0.010737	0.000483	0.001583	0.007128	0.635586	0.009501	61.168305	1446.89553	91756.617	268.584458
49	0.008211	0.004067	0.003122	0.007748	0.635586	0.009501	66.516213	1446.89553	91756.617	268.584458
50	0.005686	0.007652	0.004661	0.007480	0.602100	0.009000	70.328089	1422.23412	91572.358	268.430246
51	0.003478	0.009566	0.006524	0.016917	0.602100	0.009000	72.899559	1422.23412	91572.358	268.430246
52	0.001283	0.011480	0.008387	0.021634	0.537187	0.008030	74.580908	1541.98106	91229.802	268.142962
53	0.003460	0.013205	0.012215	0.027200	0.453536	0.006780	75.669748	1667.09352	90780.465	267.764956
54	0.009114	0.014209	0.015792	0.033667	0.365741	0.005467	76.351231	1717.42175	89316.306	267.373075
55	0.015707	0.014579	0.019038	0.041072	0.274209	0.004099	76.675841	1683.20045	89913.867	267.032136
56	0.023478	0.014591	0.022030	0.049436	0.188095	0.002812	76.831711	1509.71105	89600.395	266.772618
57	0.032695	0.014431	0.024945	0.050767	0.111348	0.001664	76.846676	1471.12900	89393.161	266.589383
58	0.043710	0.014017	0.027548	0.069058	0.036859	0.000000	76.696629	1350.10129	89248.460	266.466017
59	0.056544	0.013482	0.030571	0.080290	0.000000	0.000000	76.432956	1238.31780	89153.083	266.384625
60	0.071356	0.012844	0.034243	0.092424	0.000000	0.000000	76.097472	1138.49546	89094.501	266.334603
61	0.088578	0.011948	0.037733	0.105409	0.000000	0.000000	75.683458	1050.66189	89063.791	266.308370
62	0.108268	0.010822	0.040972	0.119181	0.000000	0.000000	75.202569	975.07432	89049.858	266.296466
63	0.130471	0.009477	0.043908	0.133660	0.000000	0.000000	74.670328	909.76832	89048.519	266.285322
64	0.155169	0.007732	0.046462	0.148760	0.000000	0.000000	74.118162	851.72136	89061.935	266.306784
65	0.182356	0.006246	0.048575	0.164375	0.000000	0.000000	73.540369	800.42837	89085.450	266.326871
66	0.211956	0.004444	0.050212	0.180391	0.000000	0.000000	72.935490	755.29735	89115.258	266.352330
67	0.243841	0.002548	0.051329	0.196689	0.000000	0.000000	72.331629	714.93000	89151.873	266.383593
68	0.277888	0.000620	0.051801	0.213138	0.000000	0.000000	71.724137	678.61753	89194.166	266.419692
69	0.313905	-0.001508	0.051918	0.229601	0.000000	0.000000	71.150779	645.87910	89240.676	266.459378
70	0.351696	-0.003193	0.051390	0.245940	0.000000	0.000000	70.535914	616.60530	89288.597	266.500251
71	0.391018	-0.005010	0.050342	0.262914	0.000000	0.000000	69.945156	590.12145	89338.380	266.542696
72	0.431576	-0.006727	0.048792	0.277677	0.000000	0.000000	69.368404	565.95721	89390.101	266.586776
73	0.473105	-0.008237	0.046791	0.292788	0.000000	0.000000	68.795259	544.17601	89441.330	266.630410
74	0.515274	-0.009693	0.044592	0.307210	0.000000	0.000000	68.148546	524.36496	89492.458	266.673956
75	0.557732	-0.010925	0.041647	0.320807	0.000000	0.000000	67.506141	506.50366	89542.000	266.716127
76	0.600126	-0.011975	0.038625	0.333451	0.000000	0.000000	66.827191	490.12284	89591.274	266.758054
77	0.642117	-0.012806	0.035368	0.345023	0.000000	0.000000	66.100615	475.11216	89639.817	266.799342
78	0.683290	-0.013475	0.031965	0.355413	0.000000	0.000000	65.298462	461.43869	89686.833	266.839317
79	0.723330	-0.013891	0.028458	0.364216	0.000000	0.000000	64.407236	448.43869	89735.603	266.880766
80	0.761736	-0.014279	0.024907	0.372244	0.000000	0.000000	63.393654	436.17828	89785.050	266.922774
81	0.798394	-0.014248	0.021362	0.378522	0.000000	0.000000	62.184607	424.43166	89836.102	266.966130
82	0.832724	-0.014179	0.017935	0.383286	0.000000	0.000000	60.687724	412.99873	89889.556	267.011506
83	0.864479	-0.013942	0.014636	0.386489	0.000000	0.000000	58.844817	401.69710	89946.186	267.059556
84	0.893488	-0.013374	0.011535	0.388099	0.000000	0.000000	57.593683	390.16392	90008.016	267.111995
85	0.919233	-0.012847	0.008695	0.390027	0.000000	0.000000	56.454776	378.23148	90075.861	267.169505
86	0.941448	-0.012387	0.006175	0.393027	0.000000	0.000000	55.52428	365.52428	90151.931	267.233951
87	0.960124	-0.011666	0.004027	0.401837	0.000000	0.000000	54.70693	351.26693	90241.152	267.309488
88	0.974933	-0.010942	0.002235	0.400000	0.000000	0.000000	54.56625	334.56625	90349.317	267.400993
89	0.985735	-0.010211	0.001031	0.400000	0.000000	0.000000	54.56625	315.01440	90478.988	267.510588
90	0.992325	-0.009657	0.000260	0.400000	0.000000	0.000000	54.56625	302.20079	90564.815	267.583065

Figure 26. - Continued.

39	0.320304	0.560686	-0.013346	0.541754	0.008098	-0.572332	0.330636	-0.750699	-0.978129	-0.177681	0.108100
40	0.315168	0.558488	-0.009815	0.606968	0.009073	-0.694031	0.400699	-0.598132	-0.980025	-0.185154	0.072530
41	0.312609	0.556209	-0.007949	0.606968	0.009073	-0.749378	0.432653	-0.597124	-0.980734	-0.187006	0.056475
42	0.310050	0.553931	-0.006405	0.640415	0.009573	-0.794629	0.458779	-0.597600	-0.981179	-0.188808	0.040404
43	0.308514	0.552289	-0.004403	0.640415	0.009573	-0.825306	0.476690	-0.303030	-0.981521	-0.189372	0.027459
44	0.306978	0.550648	-0.002725	0.652581	0.009755	-0.847566	0.489342	-0.205368	-0.981692	-0.189903	0.014509
45	0.306861	0.550715	-0.001601	0.652584	0.009755	-0.866107	0.496583	-0.167112	-0.981752	-0.190028	0.000047
46	0.306745	0.550782	-0.000478	0.652584	0.009755	-0.865707	0.499816	-0.027113	-0.981751	-0.190142	0.000047
47	0.306803	0.550749	0.000554	0.652584	0.009755	-0.864191	0.498941	0.065059	-0.981751	-0.190034	-0.000047
48	0.306861	0.550715	0.001586	0.640345	0.009572	-0.855330	0.493825	0.156679	-0.981682	-0.189915	-0.014540
49	0.309723	0.554884	0.003130	0.640345	0.009572	-0.837216	0.483367	0.355284	-0.981517	-0.189389	-0.027505
50	0.312584	0.559052	0.004674	0.607264	0.009078	-0.810513	0.467950	0.352265	-0.981172	-0.188630	-0.040465
51	0.314838	0.561056	0.006542	0.607264	0.009078	-0.770909	0.445630	0.455630	-0.980734	-0.186993	-0.056505
52	0.317092	0.563060	0.008411	0.542192	0.008105	-0.721457	0.416533	0.553173	-0.980032	-0.185118	-0.072529
53	0.321866	0.564846	0.012244	0.457155	0.006834	-0.605416	0.349537	0.715049	-0.978142	-0.177643	-0.108043
54	0.327557	0.565844	0.015822	0.368777	0.005513	-0.493111	0.2294698	0.822064	-0.975608	-0.165809	-0.143865
55	0.334286	0.566442	0.019077	0.278221	0.004159	-0.396700	0.229035	0.889116	-0.973170	-0.150471	-0.174043
56	0.342175	0.566654	0.022077	0.191730	0.002866	-0.323271	0.186640	0.927118	-0.970986	-0.133070	-0.198666
57	0.351521	0.566696	0.024983	0.133584	0.001698	-0.257577	0.148712	0.954746	-0.969619	-0.115306	-0.215707
58	0.362708	0.566552	0.027563	0.037798	0.000000	-0.221234	0.127730	0.966820	-0.968664	-0.096393	-0.228899
59	0.375743	0.566352	0.030571	0.000000	0.000000	-0.227076	0.131102	0.965012	-0.960000	0.000000	0.000000
60	0.390792	0.566125	0.034243	0.000000	0.000000	-0.212475	0.122672	0.969436	0.000000	0.000000	0.000000
61	0.408298	0.565718	0.037733	0.000000	0.000000	-0.174268	0.100613	0.979545	0.000000	0.000000	0.000000
62	0.428320	0.565169	0.040972	0.000000	0.000000	-0.141528	0.081711	0.986556	0.000000	0.000000	0.000000
63	0.450912	0.564496	0.043908	0.000000	0.000000	-0.112786	0.065117	0.991483	0.000000	0.000000	0.000000
64	0.476054	0.563720	0.046462	0.000000	0.000000	-0.086961	0.050207	0.994946	0.000000	0.000000	0.000000
65	0.503711	0.562850	0.048575	0.000000	0.000000	-0.064045	0.036977	0.997262	0.000000	0.000000	0.000000
66	0.533682	0.561899	0.050212	0.000000	0.000000	-0.043587	0.025165	0.998733	0.000000	0.000000	0.000000
67	0.566177	0.560851	0.051329	0.000000	0.000000	-0.025056	0.014466	0.999581	0.000000	0.000000	0.000000
68	0.600693	0.559735	0.051901	0.000000	0.000000	0.008362	0.004828	0.999953	0.000000	0.000000	0.000000
69	0.637335	0.558544	0.051390	0.000000	0.000000	0.006561	-0.003788	0.999971	0.000000	0.000000	0.000000
70	0.675290	0.557288	0.051390	0.000000	0.000000	0.019764	-0.011411	0.999740	0.000000	0.000000	0.000000
71	0.714900	0.555372	0.050342	0.000000	0.000000	0.031610	-0.018250	0.999334	0.000000	0.000000	0.000000
72	0.755669	0.554619	0.048792	0.000000	0.000000	0.042181	-0.024353	0.998813	0.000000	0.000000	0.000000
73	0.797302	0.553237	0.046791	0.000000	0.000000	0.051396	-0.029674	0.998237	0.000000	0.000000	0.000000
74	0.839479	0.551848	0.044392	0.000000	0.000000	0.059559	-0.034386	0.997632	0.000000	0.000000	0.000000
75	0.881840	0.550480	0.041647	0.000000	0.000000	0.066732	-0.038528	0.997027	0.000000	0.000000	0.000000
76	0.924092	0.549150	0.038625	0.000000	0.000000	0.073220	-0.042274	0.996419	0.000000	0.000000	0.000000
77	0.965832	0.547886	0.035368	0.000000	0.000000	0.078955	-0.045584	0.995835	0.000000	0.000000	0.000000
78	1.006694	0.546678	0.031965	0.000000	0.000000	0.084074	-0.048540	0.995277	0.000000	0.000000	0.000000
79	1.046359	0.545613	0.028458	0.000000	0.000000	0.089020	-0.051395	0.994703	0.000000	0.000000	0.000000
80	1.084445	0.544670	0.024907	0.000000	0.000000	0.093515	-0.053990	0.994153	0.000000	0.000000	0.000000
81	1.120667	0.543947	0.021382	0.000000	0.000000	0.097737	-0.056429	0.993611	0.000000	0.000000	0.000000
82	1.154571	0.543277	0.017935	0.000000	0.000000	0.101703	-0.058719	0.993080	0.000000	0.000000	0.000000
83	1.185892	0.542744	0.014636	0.000000	0.000000	0.105440	-0.060876	0.992561	0.000000	0.000000	0.000000
84	1.214423	0.542502	0.011535	0.000000	0.000000	0.109024	-0.062945	0.992044	0.000000	0.000000	0.000000
85	1.239799	0.542391	0.008695	0.000000	0.000000	0.112265	-0.064817	0.991562	0.000000	0.000000	0.000000
86	1.261850	0.542567	0.006175	0.000000	0.000000	0.115186	-0.066504	0.991115	0.000000	0.000000	0.000000
87	1.280197	0.542716	0.004027	0.000000	0.000000	0.117890	-0.068065	0.990691	0.000000	0.000000	0.000000
88	1.294756	0.543009	0.002295	0.000000	0.000000	0.119903	-0.069227	0.990369	0.000000	0.000000	0.000000
89	1.305361	0.543401	0.001031	0.000000	0.000000	0.122169	-0.069957	0.990164	0.000000	0.000000	0.000000
90	1.311835	0.543754	0.000260	0.000000	0.000000	0.122154	-0.070526	0.990002	0.000000	0.000000	0.000000
91	1.314000	0.543866	0.000000	0.000000	0.000000	0.061436	-0.035470	0.997481	0.000000	0.000000	0.000000
92	1.322258	0.544312	0.000000	0.000000	0.000000	0.000000	0.000000	1.000000	0.000000	0.000000	0.000000
93	1.334513	0.544754	0.000000	0.000000	0.000000	0.000000	0.000000	1.000000	0.000000	0.000000	0.000000

Figure 26. - Continued.

94 1.364833 0.545308 0.000000 0.000000 0.000000 0.000000 1.000000 0.000000 0.000000 0.000000 0.000000 0.000000

SUBROUTINE LEWICE2D HEAT TRANSFER OUTPUT FOR SLICE: 2 TIME= 120.000

POINT	XSTSV	YSTSV	ZSTSV	SSTRM	BETA	DDICE	VEDGE	HTC	PEDGE	TEDGE
1	1.312290	0.540905	0.000000	-0.388099	0.000000	0.000000	57.857106	0.000000	90546.893	267.567934
2	1.310106	0.540758	-0.000260	-0.386489	0.000000	0.000000	58.666311	316.63039	90491.343	267.521024
3	1.303630	0.540402	-0.001031	-0.383286	0.000000	0.000000	60.259352	333.71839	90379.803	267.426769
4	1.293022	0.540007	-0.002295	-0.378522	0.000000	0.000000	61.740660	350.35560	90273.497	267.336859
5	1.278453	0.539697	-0.004027	-0.372246	0.000000	0.000000	62.914915	364.31692	90187.457	267.264035
6	1.260120	0.539552	-0.006175	-0.364219	0.000000	0.000000	63.876230	376.50588	90115.858	267.203395
7	1.238061	0.539382	-0.008695	-0.355415	0.000000	0.000000	64.700040	387.71493	90053.670	267.150698
8	1.212660	0.539431	-0.011535	-0.345027	0.000000	0.000000	65.425756	398.38029	89998.252	267.103716
9	1.184138	0.539688	-0.014636	-0.333455	0.000000	0.000000	66.067870	408.67166	89948.724	267.061709
10	1.152751	0.540108	-0.017935	-0.320811	0.000000	0.000000	66.658523	418.99098	89902.755	267.022707
11	1.118811	0.540715	-0.021382	-0.307213	0.000000	0.000000	67.213851	429.57214	89859.178	266.985721
12	1.082648	0.541540	-0.024907	-0.292792	0.000000	0.000000	67.730929	440.42093	89818.291	266.951006
13	1.044569	0.542494	-0.028449	-0.277681	0.000000	0.000000	68.248845	452.10275	89777.037	266.915968
14	1.004868	0.543498	-0.031945	-0.262018	0.000000	0.000000	68.760101	464.12251	89736.019	266.881119
15	0.963985	0.544669	-0.035348	-0.245945	0.000000	0.000000	69.271158	478.22657	89694.238	266.845611
16	0.922241	0.545927	-0.038625	-0.229606	0.000000	0.000000	69.812306	493.25979	89650.680	266.808579
17	0.879982	0.547211	-0.041647	-0.213143	0.000000	0.000000	70.360719	509.82514	89605.710	266.770334
18	0.837605	0.548583	-0.044392	-0.196694	0.000000	0.000000	70.936987	528.36280	89558.095	266.729825
19	0.795424	0.549968	-0.046791	-0.180395	0.000000	0.000000	71.536779	549.04615	89508.403	266.687531
20	0.753782	0.551332	-0.048702	-0.164380	0.000000	0.000000	72.140441	572.04439	89457.465	266.644160
21	0.713006	0.552674	-0.050335	-0.148766	0.000000	0.000000	72.761972	597.83745	89404.863	266.599353
22	0.673399	0.553977	-0.051390	-0.133666	0.000000	0.000000	73.399525	626.96793	89350.460	266.552993
23	0.635236	0.555237	-0.051918	-0.119185	0.000000	0.000000	74.031924	659.69013	89296.051	266.506607
24	0.598793	0.556426	-0.051901	-0.105414	0.000000	0.000000	74.650174	696.58819	89242.431	266.460875
25	0.564281	0.557549	-0.051339	-0.092428	0.000000	0.000000	75.253239	738.17400	89191.476	266.417397
26	0.531902	0.558590	-0.050212	-0.080294	0.000000	0.000000	75.840000	785.20760	89144.765	266.377524
27	0.501816	0.559550	-0.048575	-0.069062	0.000000	0.000000	76.403633	838.86390	89103.353	266.342162
28	0.474159	0.560421	-0.046462	-0.058770	0.000000	0.000000	76.932809	899.88575	89071.203	266.311670
29	0.449008	0.561198	-0.043908	-0.049439	0.000000	0.000000	77.424447	969.23379	89052.307	266.286626
30	0.426425	0.561868	-0.040900	-0.041074	0.000000	0.000000	77.885014	1048.40286	89050.457	266.269678
31	0.406388	0.562411	-0.037733	-0.033669	0.000000	0.000000	78.317400	1138.78439	89120.562	266.261423
32	0.388879	0.562794	-0.034243	-0.027204	0.000000	0.000000	78.714570	1241.14570	89208.309	266.256859
33	0.373816	0.562997	-0.030571	-0.021637	0.037003	0.000000	79.081102	1355.99707	89349.951	266.253176
34	0.360812	0.563140	-0.027589	-0.016918	0.01681	0.000000	79.405457	1478.91743	89565.014	266.252559
35	0.349709	0.563179	-0.025060	-0.012982	0.002953	0.000000	79.685324	1598.15502	89871.926	266.253712
36	0.340445	0.562993	-0.022282	-0.009749	0.004154	0.000000	79.918466	1690.88827	90274.860	266.256542
37	0.332628	0.562563	-0.019485	-0.007128	0.005518	0.000000	80.101171	1723.68816	90734.431	267.261544
38	0.325990	0.561813	-0.016540	-0.005021	0.008335	0.000000	80.233379	1674.72333	91172.528	268.094854
39	0.320304	0.560686	-0.013346	-0.003335	0.011754	0.000000	80.31681	1560.17921	91499.051	268.368833
40	0.315168	0.558488	-0.009815	-0.001988	0.01681	0.000000	80.34683	1466.77433	91671.726	268.513438
41	0.312609	0.556209	-0.007949	-0.000941	0.020973	0.000000	80.31681	1352.75822	91727.526	268.560126
42	0.310050	0.553931	-0.006082	-0.000246	0.025755	0.000000	80.233379	1223.75822	91727.526	268.560126
43	0.308514	0.552289	-0.004403	-0.000246	0.029755	0.000000	80.09755	1093.13545	91727.513	268.560115
44	0.306978	0.550648	-0.002723	-0.000091	0.032581	0.000000	79.918466	967.13545	91670.402	268.560115
45	0.306861	0.550715	-0.001601	-0.000198	0.035258	0.000000	79.685324	846.13545	91670.402	268.560115
46	0.306782	0.550782	-0.000478	-0.000335	0.037584	0.000000	79.405457	730.13545	91670.402	268.560115
47	0.306803	0.550749	-0.000554	-0.000521	0.039755	0.000000	79.101171	623.13545	91670.402	268.560115
48	0.306861	0.550715	0.001586	0.007128	0.040345	0.000000	78.714570	525.13545	91670.402	268.560115

Figure 26. - Continued.

49	0.309173	0.554884	0.003130	0.009748	0.640345	0.009572	67.094595	1525.13545	91670.402	268.512330
50	0.312584	0.559052	0.004674	0.012981	0.607264	0.009078	70.809084	1469.06540	91496.377	268.366591
51	0.314838	0.561056	0.006542	0.016917	0.607264	0.009078	73.430532	1469.06540	91496.377	268.366591
52	0.317092	0.563060	0.008411	0.021634	0.542192	0.008105	75.064299	1561.81380	91169.598	268.092393
53	0.321866	0.564846	0.012244	0.027200	0.457155	0.006834	76.072941	1676.21438	90730.865	267.723148
54	0.324286	0.565844	0.015822	0.033667	0.368777	0.005513	76.623330	1725.04053	90270.722	267.334511
55	0.327557	0.566842	0.019077	0.041072	0.004159	0.004159	76.824999	1691.51798	89868.565	266.993689
56	0.334215	0.566654	0.022077	0.049436	0.002866	0.002866	76.796643	1598.50755	89562.067	266.733205
57	0.3351521	0.566696	0.024983	0.058767	0.191730	0.001698	76.580040	1470.91046	89347.002	266.550720
58	0.362700	0.566552	0.027563	0.069058	0.037798	0.000000	76.216770	1356.11479	89206.279	266.430029
59	0.375743	0.566352	0.030571	0.080290	0.000000	0.000000	75.741347	1241.74506	89117.433	266.354187
60	0.390792	0.566125	0.034243	0.092424	0.000000	0.000000	75.205906	1138.95687	89068.479	266.312375
61	0.408298	0.565718	0.037733	0.105409	0.000000	0.000000	74.620204	1047.91336	89050.459	266.296979
62	0.428320	0.565169	0.040972	0.119181	0.000000	0.000000	74.006999	968.65209	89053.174	266.299299
63	0.450912	0.564496	0.043908	0.133660	0.000000	0.000000	73.365056	899.53048	89071.628	266.315064
64	0.476054	0.563720	0.046462	0.148760	0.000000	0.000000	72.739845	838.36242	89104.673	266.343290
65	0.503711	0.562850	0.048575	0.164375	0.000000	0.000000	72.120172	784.62380	89146.765	266.379232
66	0.533802	0.561899	0.050212	0.180391	0.000000	0.000000	71.504173	737.57911	89193.873	266.419442
67	0.566177	0.560851	0.051329	0.196689	0.000000	0.000000	70.912951	696.01686	89245.340	266.463100
68	0.600693	0.559735	0.051901	0.213138	0.000000	0.000000	70.339223	659.15837	89298.748	266.508907
69	0.637135	0.558544	0.051918	0.229601	0.000000	0.000000	69.793005	626.43356	89353.412	266.555509
70	0.675290	0.557288	0.051390	0.245940	0.000000	0.000000	69.259744	597.53376	89406.743	266.600955
71	0.714900	0.555972	0.050342	0.262014	0.000000	0.000000	68.741613	571.80800	89459.173	266.645615
72	0.755669	0.554619	0.048792	0.277677	0.000000	0.000000	68.243182	548.68122	89510.869	266.689630
73	0.797302	0.553237	0.046791	0.292787	0.000000	0.000000	67.727380	528.10104	89560.089	266.731521
74	0.839479	0.551848	0.044392	0.307209	0.000000	0.000000	67.210118	509.61285	89607.479	266.771839
75	0.881860	0.550480	0.041647	0.320807	0.000000	0.000000	66.650404	493.08595	89652.256	266.809920
76	0.924092	0.549150	0.038625	0.333451	0.000000	0.000000	66.062028	478.08523	89695.650	266.846811
77	0.966832	0.547886	0.035368	0.345023	0.000000	0.000000	65.421269	464.46045	89737.507	266.883884
78	1.006694	0.546678	0.031965	0.355412	0.000000	0.000000	64.698502	452.12205	89777.490	266.916353
79	1.046359	0.545613	0.028458	0.364516	0.000000	0.000000	63.875618	440.46357	89818.572	266.951245
80	1.084445	0.544670	0.024907	0.372244	0.000000	0.000000	62.915030	429.49411	89860.189	266.984579
81	1.120667	0.543947	0.021382	0.378522	0.000000	0.000000	61.743196	418.97164	89903.390	267.023245
82	1.154571	0.543277	0.017935	0.383286	0.000000	0.000000	60.262204	408.67821	89949.177	267.062093
83	1.185892	0.542744	0.014636	0.386488	0.000000	0.000000	58.679472	398.40083	89998.597	267.104008
84	1.214423	0.542502	0.011535	0.388099	0.000000	0.000000	57.882909	387.76707	90053.787	267.150797
85	1.239799	0.542391	0.008695	0.390027	0.000000	0.000000	58.505545	376.56546	90115.904	267.203434
86	1.261850	0.542567	0.006175	0.393837	0.000000	0.000000	60.057908	364.30133	90187.449	267.264028
87	1.280197	0.542716	0.004027	0.401837	0.000000	0.000000	61.877022	350.44267	90273.313	267.336703
88	1.294756	0.543009	0.002295	0.408000	0.000000	0.000000	61.800000	333.80412	90379.601	267.426598
89	1.303361	0.543401	0.001031	0.000000	0.000000	0.000000	0.000000	316.81816	90490.433	267.520255
90	1.311835	0.543754	0.000260	0.000000	0.000000	0.000000	0.000000	308.48022	90545.133	267.566449
91	1.314000	0.543866	0.000000	0.000000	0.000000	0.000000	0.000000	314.69021	90502.438	267.530395
92	1.322258	0.544312	0.000000	0.000000	0.000000	0.000000	0.000000	330.53020	90394.067	267.438827
93	1.334513	0.544754	0.000000	0.000000	0.000000	0.000000	0.000000	349.13090	90263.585	267.328473
94	1.364833	0.5445308	0.000000	0.000000	0.000000	0.000000	0.000000	334.56625	0.000	0.000000

*** SUBROUTINE LEWICE2D COMPLETE ***

CPU TIME = 1338.091

Figure 26. - Continued.

SUBROUTINE LEWICE2D GEOMETRY OUTPUT FOR SLICE: 3 TIME= 120.000

POINT	XSTSV	YSTSV	ZSTSV	BETA	DICE	XNSTRM	YNSTRM	ZNSTRM	XNTRJ	YNTRJ	ZNTRJ
1	0.686880	-0.542340	0.000000	0.000000	0.000000	0.122563	-0.070762	-0.989935	0.000000	0.000000	0.000000
2	0.684647	-0.542570	-0.000260	0.000000	0.000000	0.122154	-0.070526	-0.990002	0.000000	0.000000	0.000000
3	0.678010	-0.543206	-0.001031	0.000000	0.000000	0.121166	-0.069955	-0.990164	0.000000	0.000000	0.000000
4	0.667189	-0.543969	-0.002295	0.000000	0.000000	0.119901	-0.069225	-0.990369	0.000000	0.000000	0.000000
5	0.652253	-0.544915	-0.004027	0.000000	0.000000	0.117921	-0.068082	-0.990686	0.000000	0.000000	0.000000
6	0.633478	-0.545825	-0.006175	0.000000	0.000000	0.115193	-0.066507	-0.991114	0.000000	0.000000	0.000000
7	0.610943	-0.546820	-0.008695	0.000000	0.000000	0.112261	-0.064814	-0.991563	0.000000	0.000000	0.000000
8	0.585036	-0.547647	-0.011535	0.000000	0.000000	0.109045	-0.062957	-0.992041	0.000000	0.000000	0.000000
9	0.555832	-0.548571	-0.014636	0.000000	0.000000	0.105440	-0.060876	-0.992561	0.000000	0.000000	0.000000
10	0.523696	-0.549449	-0.017935	0.000000	0.000000	0.101703	-0.058718	-0.993080	0.000000	0.000000	0.000000
11	0.488962	-0.550218	-0.021382	0.000000	0.000000	0.097737	-0.056428	-0.993611	0.000000	0.000000	0.000000
12	0.451954	-0.550855	-0.024907	0.000000	0.000000	0.093400	-0.053924	-0.994167	0.000000	0.000000	0.000000
13	0.412998	-0.551420	-0.028449	0.000000	0.000000	0.089015	-0.051393	-0.994704	0.000000	0.000000	0.000000
14	0.372480	-0.551831	-0.031965	0.000000	0.000000	0.084184	-0.048804	-0.995264	0.000000	0.000000	0.000000
15	0.330775	-0.552084	-0.035368	0.000000	0.000000	0.078955	-0.045584	-0.995835	0.000000	0.000000	0.000000
16	0.288265	-0.552152	-0.038625	0.000000	0.000000	0.073220	-0.042274	-0.996419	0.000000	0.000000	0.000000
17	0.245352	-0.552002	-0.041647	0.000000	0.000000	0.066732	-0.038528	-0.997027	0.000000	0.000000	0.000000
18	0.202408	-0.551610	-0.044392	0.000000	0.000000	0.059559	-0.034386	-0.997632	0.000000	0.000000	0.000000
19	0.157976	-0.550973	-0.046791	0.000000	0.000000	0.051396	-0.029674	-0.998237	0.000000	0.000000	0.000000
20	0.117878	-0.550086	-0.048792	0.000000	0.000000	0.042073	-0.024291	-0.998819	0.000000	0.000000	0.000000
21	0.076978	-0.548960	-0.050333	0.000000	0.000000	0.031616	-0.018254	-0.999333	0.000000	0.000000	0.000000
22	0.037393	-0.547617	-0.051390	0.000000	0.000000	0.019877	-0.011476	-0.999737	0.000000	0.000000	0.000000
23	0.000604	-0.546080	-0.051918	0.000000	0.000000	0.006559	-0.003787	-0.999971	0.000000	0.000000	0.000000
24	0.036764	-0.544390	-0.051901	0.000000	0.000000	-0.008362	0.004828	-0.999953	0.000000	0.000000	0.000000
25	0.070895	-0.542609	-0.051329	0.000000	0.000000	-0.025056	0.014466	-0.999581	0.000000	0.000000	0.000000
26	0.102812	-0.540767	-0.050212	0.000000	0.000000	-0.043587	0.025165	-0.998733	0.000000	0.000000	0.000000
27	0.132391	-0.538930	-0.048575	0.000000	0.000000	-0.064045	0.036977	-0.997262	0.000000	0.000000	0.000000
28	0.159516	-0.537136	-0.046462	0.000000	0.000000	-0.086941	0.050196	-0.994948	0.000000	0.000000	0.000000
29	0.184136	-0.535439	-0.043908	0.000000	0.000000	-0.112625	0.065024	-0.991508	0.000000	0.000000	0.000000
30	0.206212	-0.533891	-0.040980	0.000000	0.000000	-0.141537	0.081717	-0.986554	0.000000	0.000000	0.000000
31	0.225777	-0.532532	-0.037733	0.000000	0.000000	-0.174468	0.100729	-0.979497	0.000000	0.000000	0.000000
32	0.242854	-0.531401	-0.034243	0.000000	0.000000	-0.212526	0.122702	-0.969421	0.000000	0.000000	0.000000
33	0.257530	-0.530527	-0.030571	0.000000	0.000000	-0.226744	0.125756	-0.965740	0.000000	0.000000	0.000000
34	0.270205	-0.529776	-0.027640	0.000000	0.001786	-0.215118	0.124198	-0.960658	0.000000	0.000000	0.000000
35	0.281020	-0.529173	-0.025178	0.000000	0.002993	-0.215118	0.143425	-0.957975	-0.971128	-0.047564	0.233761
36	0.290010	-0.528829	-0.022430	0.000000	0.004332	-0.209934	0.143425	-0.957975	-0.973132	-0.065538	0.220698
37	0.297537	-0.528692	-0.019649	0.000000	0.005713	-0.309308	0.178940	-0.933767	-0.975597	-0.082541	0.203447
38	0.303866	-0.528818	-0.016711	0.000000	0.007074	-0.375308	0.216684	-0.901217	-0.978922	-0.099177	0.178525
39	0.309270	-0.529330	-0.013521	0.000000	0.008386	-0.460115	0.265936	-0.846825	-0.982463	-0.113856	0.147657
40	0.313982	-0.530671	-0.009968	0.000000	0.009384	-0.567981	0.327924	-0.754893	-0.985883	-0.125272	0.111066
41	0.316074	-0.532104	-0.008079	0.000000	0.009384	-0.691893	0.399465	-0.601425	-0.988366	-0.132487	0.074657
42	0.318167	-0.533536	-0.006189	0.000000	0.009891	-0.793937	0.431884	-0.503889	-0.989230	-0.136308	0.058179
43	0.320682	-0.536852	-0.004485	0.000000	0.009891	-0.793937	0.458379	-0.399441	-0.989230	-0.136308	0.058179
44	0.323197	-0.540168	-0.002780	0.000000	0.009891	-0.824812	0.476205	-0.304818	-0.990217	-0.136308	0.058179
45	0.327280	-0.546969	-0.001638	0.000000	0.010081	-0.847254	0.489162	-0.207078	-0.990436	-0.137138	0.041684
46	0.331371	-0.553770	-0.000495	0.000000	0.010081	-0.859988	0.496514	-0.117879	-0.990509	-0.137244	0.007514
47	0.330071	-0.551656	0.000554	0.000000	0.010081	-0.865693	0.499808	-0.027716	-0.990524	-0.137343	0.000048
48	0.328771	-0.549543	0.001603	0.000000	0.009891	-0.864183	0.498936	0.065193	-0.990513	-0.137218	-0.007469
49	0.325682	-0.544993	0.003166	0.000000	0.009891	-0.855211	0.493756	0.157539	-0.990444	-0.137084	-0.014986
50	0.322593	-0.540443	0.004729	0.000000	0.009387	-0.810099	0.483224	0.256861	-0.990229	-0.136543	-0.028338
51	0.320393	-0.538563	0.006620	0.000000	0.009387	-0.770083	0.467711	0.353534	-0.989833	-0.135977	-0.041684
							0.444608	0.457488	-0.989246	-0.134319	-0.058168

Figure 26. - Continued.

POINT	XSTSV	YSTSV	ZSTSV	SSTRM	BETA	DDICE	VEDGE	HTC	PEDGE	TEDGE
52	-0.318192	-0.536682	0.008511	0.561338	0.008391	-0.720102	0.415751	0.555222	-0.988382	-0.132383
53	-0.313294	-0.534791	0.012377	0.473212	0.007074	-0.602356	0.347770	0.718487	-0.985892	-0.111037
54	-0.307685	-0.534067	0.015966	0.381685	0.005706	-0.489414	0.282563	0.825005	-0.982469	-0.113034
55	-0.291136	-0.533887	0.019217	0.289211	0.004323	-0.393469	0.227169	0.890829	-0.978930	-0.178510
56	-0.293389	-0.533998	0.022204	0.200336	0.002995	-0.320362	0.184950	0.929072	-0.975621	-0.203350
57	-0.282239	-0.534357	0.025090	0.120447	0.001800	-0.253476	0.146344	0.968198	-0.973113	-0.220794
58	-0.273291	-0.534985	0.027611	0.041249	0.000000	-0.216667	0.130027	0.965594	-0.971128	-0.047656
59	-0.260548	-0.535738	0.030571	0.000000	0.000000	-0.225213	0.122672	0.9699436	0.000000	0.000000
60	-0.245862	-0.536592	0.034243	0.000000	0.000000	-0.212475	0.122672	0.9799545	0.000000	0.000000
61	-0.228768	-0.537112	0.037733	0.000000	0.000000	-0.174268	0.100613	0.986556	0.000000	0.000000
62	-0.209203	-0.538054	0.040972	0.000000	0.000000	-0.141528	0.081711	0.991483	0.000000	0.000000
63	-0.187114	-0.540598	0.043908	0.000000	0.000000	-0.112786	0.065117	0.991483	0.000000	0.000000
64	-0.162497	-0.542284	0.046462	0.000000	0.000000	-0.086961	0.050207	0.994946	0.000000	0.000000
65	-0.135796	-0.544077	0.048575	0.000000	0.000000	-0.064045	0.036977	0.997262	0.000000	0.000000
66	-0.105796	-0.545919	0.050212	0.000000	0.000000	-0.043587	0.025165	0.998733	0.000000	0.000000
67	-0.073869	-0.547742	0.051329	0.000000	0.000000	-0.025056	0.014466	0.999581	0.000000	0.000000
68	-0.039735	-0.549520	0.051901	0.000000	0.000000	-0.008362	0.004828	0.999953	0.000000	0.000000
69	-0.003566	-0.551184	0.051918	0.000000	0.000000	-0.006561	-0.003788	0.999971	0.000000	0.000000
70	0.034445	-0.552690	0.051390	0.000000	0.000000	0.019764	-0.011411	0.999740	0.000000	0.000000
71	0.074067	-0.553984	0.050342	0.000000	0.000000	0.031610	-0.018250	0.999334	0.000000	0.000000
72	0.114987	-0.555075	0.048792	0.000000	0.000000	0.042181	-0.024353	0.998813	0.000000	0.000000
73	0.156923	-0.555832	0.046791	0.000000	0.000000	0.051396	-0.029674	0.998237	0.000000	0.000000
74	0.199251	-0.556541	0.044592	0.000000	0.000000	0.059559	-0.034386	0.997632	0.000000	0.000000
75	0.242520	-0.556888	0.041647	0.000000	0.000000	0.066732	-0.038528	0.997027	0.000000	0.000000
76	0.285455	-0.557001	0.038625	0.000000	0.000000	0.073220	-0.042274	0.996419	0.000000	0.000000
77	0.327918	-0.556910	0.035368	0.000000	0.000000	0.078955	-0.045504	0.995835	0.000000	0.000000
78	0.369699	-0.556631	0.031965	0.000000	0.000000	0.084074	-0.048540	0.995277	0.000000	0.000000
79	0.410248	-0.556165	0.028458	0.000000	0.000000	0.089020	-0.051396	0.994703	0.000000	0.000000
80	0.449236	-0.555545	0.024907	0.000000	0.000000	0.093514	-0.053990	0.994153	0.000000	0.000000
81	0.486265	-0.554871	0.021382	0.000000	0.000000	0.097737	-0.056428	0.993611	0.000000	0.000000
82	0.521024	-0.554040	0.017935	0.000000	0.000000	0.101703	-0.058718	0.993080	0.000000	0.000000
83	0.553141	-0.553215	0.014636	0.000000	0.000000	0.105440	-0.060876	0.992561	0.000000	0.000000
84	0.582337	-0.552304	0.011535	0.000000	0.000000	0.109024	-0.062945	0.992044	0.000000	0.000000
85	0.608378	-0.551263	0.008695	0.000000	0.000000	0.112265	-0.064816	0.991562	0.000000	0.000000
86	0.630850	-0.550360	0.006175	0.000000	0.000000	0.115187	-0.066503	0.991115	0.000000	0.000000
87	0.649653	-0.549418	0.004027	0.000000	0.000000	0.117890	-0.068064	0.990691	0.000000	0.000000
88	0.664643	-0.548380	0.002235	0.000000	0.000000	0.119901	-0.069225	0.990369	0.000000	0.000000
89	0.675456	-0.547630	0.001031	0.000000	0.000000	0.121166	-0.069955	0.990164	0.000000	0.000000
90	0.682041	-0.547084	0.000260	0.000000	0.000000	0.122154	-0.070526	0.990002	0.000000	0.000000
91	0.684222	-0.546944	0.000000	0.000000	0.000000	0.061436	-0.035470	0.997481	0.000000	0.000000
92	0.692634	-0.546232	0.000000	0.000000	0.000000	0.000000	0.000000	1.000000	0.000000	0.000000
93	0.705168	-0.545307	0.000000	0.000000	0.000000	0.000000	0.000000	1.000000	0.000000	0.000000
94	0.736144	-0.543615	0.000000	0.000000	0.000000	0.000000	0.000000	1.000000	0.000000	0.000000
1	0.686880	-0.542340	0.000000	-0.388100	0.000000	0.000000	59.062838	0.00000	90463.849	267.497798
2	0.686647	-0.542570	-0.000260	-0.386489	0.000000	0.000000	59.864798	328.52792	90407.698	267.450348
3	0.678010	-0.543206	-0.001031	-0.303286	0.000000	0.000000	61.439953	345.78048	90295.278	267.355287
4	0.667189	-0.543969	-0.002295	-0.378522	0.000000	0.000000	62.936914	362.9747	90185.831	267.262658
5	0.652253	-0.544915	-0.004027	-0.372247	0.000000	0.000000	64.151082	377.74487	90095.195	267.185089
6	0.633678	-0.545825	-0.006175	-0.364519	0.000000	0.000000	65.167929	390.95151	90018.009	267.120467

SUBROUTINE LEWICE2D HEAT TRANSFER OUTPUT FOR SLICE: 3 TIME= 120.000

Figure 26. - Continued.

7	0.610943	-0.546820	-0.008695	-0.355415	0.000000	0.000000	66.051956	403.28884	89949.957	267.062755
8	0.585036	-0.547447	-0.011535	-0.345028	0.000000	0.000000	66.831207	415.07568	89889.241	267.011259
9	0.555882	-0.548571	-0.014636	-0.333455	0.000000	0.000000	67.510197	426.36562	89835.782	266.965858
10	0.523696	-0.549449	-0.017935	-0.320811	0.000000	0.000000	68.112890	437.46286	89787.895	266.925102
11	0.488962	-0.550218	-0.021382	-0.307214	0.000000	0.000000	68.652944	448.56414	89744.640	266.888445
12	0.451954	-0.550855	-0.024907	-0.292792	0.000000	0.000000	69.129461	459.68673	89706.203	266.855781
13	0.412998	-0.551420	-0.028449	-0.277681	0.000000	0.000000	69.583827	471.42576	89669.316	266.824424
14	0.372480	-0.551831	-0.031965	-0.262018	0.000000	0.000000	70.011995	483.80738	89634.344	266.794668
15	0.330775	-0.552084	-0.035368	-0.245945	0.000000	0.000000	70.428810	497.13294	89600.103	266.765585
16	0.288252	-0.552152	-0.038625	-0.229606	0.000000	0.000000	70.847434	511.72176	89565.519	266.736142
17	0.245352	-0.552002	-0.041647	-0.213143	0.000000	0.000000	71.263652	527.67981	89530.940	266.706714
18	0.202408	-0.551610	-0.044392	-0.196694	0.000000	0.000000	71.692436	545.44191	89495.114	266.676218
19	0.159796	-0.550973	-0.046791	-0.180395	0.000000	0.000000	72.125583	565.16174	89458.633	266.645154
20	0.117878	-0.550086	-0.048792	-0.164380	0.000000	0.000000	72.564556	586.95756	89422.465	266.614349
21	0.073533	-0.548960	-0.050333	-0.148766	0.000000	0.000000	72.980384	611.26077	89386.276	266.583517
22	0.030609	-0.547617	-0.051390	-0.133666	0.000000	0.000000	73.404972	638.55520	89349.993	266.552595
23	-0.000609	-0.546080	-0.051918	-0.119185	0.000000	0.000000	73.807217	669.01454	89315.434	266.523135
24	-0.036754	-0.544390	-0.051329	-0.105414	0.000000	0.000000	74.180212	699.16121	89283.229	266.495673
25	-0.070895	-0.542609	-0.049439	-0.092428	0.000000	0.000000	74.506844	730.16121	89254.900	266.471511
26	-0.102812	-0.540767	-0.046575	-0.080294	0.000000	0.000000	74.775914	764.62687	89231.474	266.451527
27	-0.132351	-0.538930	-0.043908	-0.068770	0.000000	0.000000	74.987097	800.92228	89213.033	266.435792
28	-0.159516	-0.537136	-0.041642	-0.058770	0.000000	0.000000	75.111018	839.26358	89202.188	266.426538
29	-0.206212	-0.535391	-0.040980	-0.049439	0.000000	0.000000	75.116851	880.26020	89201.677	266.426102
30	-0.225777	-0.533832	-0.037733	-0.041074	0.000000	0.000000	74.973964	929.86020	89201.677	266.426102
31	-0.242854	-0.532401	-0.034243	-0.033669	0.000000	0.000000	74.624838	1029.43027	89214.181	266.436772
32	-0.257550	-0.531027	-0.030571	-0.027204	0.000000	0.000000	74.264838	1115.50375	89244.637	266.462756
33	-0.270205	-0.529776	-0.027640	-0.021637	0.000000	0.000000	73.975899	1213.82686	89300.889	266.510733
34	-0.281020	-0.529173	-0.025178	-0.019498	0.000000	0.000000	72.919106	1324.89204	89391.496	266.587965
35	-0.290010	-0.528629	-0.022350	-0.015982	0.000000	0.000000	71.337312	1444.07693	89333.134	266.708582
36	-0.297557	-0.528092	-0.019649	-0.009749	0.000000	0.000000	68.339859	1559.45264	89745.692	266.809339
37	-0.302866	-0.528818	-0.016711	-0.007128	0.000000	0.000000	64.775385	1674.69731	90047.944	267.145845
38	-0.309270	-0.529330	-0.013521	-0.005021	0.000000	0.000000	59.331688	1784.69731	90445.107	267.481963
39	-0.316074	-0.530371	-0.009968	-0.003335	0.000000	0.000000	52.450698	1874.69731	90898.798	267.866634
40	-0.318177	-0.531204	-0.008079	-0.001988	0.000000	0.000000	44.937801	1942.60006	91321.875	268.228646
41	-0.320682	-0.531856	-0.006189	-0.001246	0.000000	0.000000	38.428051	2000.60006	91654.045	268.498640
42	-0.322593	-0.532392	-0.004485	-0.000720	0.000000	0.000000	34.503227	2058.60006	91824.300	268.641048
43	-0.323197	-0.532784	-0.003070	-0.000491	0.000000	0.000000	33.010471	2116.60006	91824.300	268.641048
44	-0.323371	-0.533066	-0.002270	-0.000338	0.000000	0.000000	32.936919	2174.60006	91824.300	268.641048
45	-0.323371	-0.533236	-0.001685	-0.000246	0.000000	0.000000	32.936919	2232.60006	91824.300	268.641048
46	-0.323371	-0.533336	-0.001280	-0.000198	0.000000	0.000000	32.936919	2290.60006	91824.300	268.641048
47	-0.323371	-0.533370	-0.000995	-0.000153	0.000000	0.000000	32.936919	2348.60006	91824.300	268.641048
48	-0.323371	-0.533370	-0.000720	-0.000118	0.000000	0.000000	32.936919	2406.60006	91824.300	268.641048
49	-0.323371	-0.533370	-0.000502	-0.000081	0.000000	0.000000	32.936919	2464.60006	91824.300	268.641048
50	-0.323371	-0.533370	-0.000338	-0.000056	0.000000	0.000000	32.936919	2522.60006	91824.300	268.641048
51	-0.323371	-0.533370	-0.000246	-0.000041	0.000000	0.000000	32.936919	2580.60006	91824.300	268.641048
52	-0.323371	-0.533370	-0.000198	-0.000033	0.000000	0.000000	32.936919	2638.60006	91824.300	268.641048
53	-0.323371	-0.533370	-0.000153	-0.000024	0.000000	0.000000	32.936919	2696.60006	91824.300	268.641048
54	-0.323371	-0.533370	-0.000118	-0.000018	0.000000	0.000000	32.936919	2754.60006	91824.300	268.641048
55	-0.323371	-0.533370	-0.000081	-0.000014	0.000000	0.000000	32.936919	2812.60006	91824.300	268.641048
56	-0.323371	-0.533370	-0.000056	-0.000011	0.000000	0.000000	32.936919	2870.60006	91824.300	268.641048
57	-0.323371	-0.533370	-0.000041	-0.000008	0.000000	0.000000	32.936919	2928.60006	91824.300	268.641048
58	-0.323371	-0.533370	-0.000033	-0.000006	0.000000	0.000000	32.936919	2986.60006	91824.300	268.641048
59	-0.323371	-0.533370	-0.000024	-0.000005	0.000000	0.000000	32.936919	3044.60006	91824.300	268.641048
60	-0.323371	-0.533370	-0.000018	-0.000004	0.000000	0.000000	32.936919	3102.60006	91824.300	268.641048
61	-0.323371	-0.533370	-0.000014	-0.000003	0.000000	0.000000	32.936919	3160.60006	91824.300	268.641048

Figure 26. - Continued.

62	-0.209203	-0.539054	0.040972	0.119181	0.000000	0.000000	73.766479	954.17382	89207.287	266.430889
63	-0.187114	-0.540598	0.043908	0.133660	0.000000	0.000000	73.364139	889.97326	89206.675	266.430197
64	-0.162497	-0.542284	0.046462	0.148760	0.000000	0.000000	72.954537	833.61024	89217.310	266.439442
65	-0.135373	-0.544077	0.048575	0.164375	0.000000	0.000000	72.532777	784.30970	89235.684	266.455119
66	-0.105796	-0.545919	0.050212	0.180391	0.000000	0.000000	72.097231	741.16952	89258.910	266.474931
67	-0.073869	-0.547742	0.051329	0.196689	0.000000	0.000000	71.670042	702.91642	89286.991	266.498882
68	-0.039735	-0.549520	0.051901	0.213138	0.000000	0.000000	71.245312	668.80878	89318.942	266.526126
69	-0.003566	-0.551184	0.051918	0.229188	0.000000	0.000000	70.828262	638.33804	89353.491	266.555726
70	0.034445	-0.552690	0.051390	0.245940	0.000000	0.000000	70.417722	611.28946	89388.479	266.585393
71	0.074067	-0.553984	0.050342	0.262014	0.000000	0.000000	70.01807	587.02310	89424.310	266.615921
72	0.114987	-0.555075	0.048792	0.277677	0.000000	0.000000	69.588449	565.08134	89461.106	266.647261
73	0.156923	-0.555932	0.046791	0.292788	0.000000	0.000000	69.138949	545.45349	89496.991	266.677815
74	0.199551	-0.556541	0.044392	0.307210	0.000000	0.000000	68.656456	527.73680	89532.467	266.708014
75	0.242520	-0.556888	0.041647	0.320807	0.000000	0.000000	68.123912	511.81598	89566.726	266.737169
76	0.285455	-0.557001	0.038625	0.333451	0.000000	0.000000	67.525807	497.25903	89601.017	266.766342
77	0.327978	-0.556910	0.035368	0.345023	0.000000	0.000000	66.849220	483.92917	89635.179	266.795398
78	0.369699	-0.556631	0.031965	0.355413	0.000000	0.000000	66.072844	471.73150	89668.939	266.824104
79	0.410248	-0.556165	0.028458	0.364516	0.000000	0.000000	65.188551	460.83389	89705.443	266.855135
80	0.449236	-0.555545	0.024907	0.372244	0.000000	0.000000	64.171126	448.81506	89744.358	266.888205
81	0.486265	-0.554871	0.021382	0.378522	0.000000	0.000000	62.957541	437.79334	89787.016	266.924445
82	0.521024	-0.554060	0.017935	0.383286	0.000000	0.000000	61.459640	426.73623	89834.546	266.964809
83	0.553141	-0.553215	0.014636	0.386489	0.000000	0.000000	59.891574	415.46366	89887.799	267.010014
84	0.582337	-0.552304	0.011535	0.388099	0.000000	0.000000	59.103088	403.68970	89948.338	267.061382
85	0.608378	-0.551263	0.008695	0.390027	0.000000	0.000000	59.669768	391.33356	90016.431	267.119130
86	0.630850	-0.550360	0.006175	0.393837	0.000000	0.000000	61.113472	378.10561	90093.685	267.184609
87	0.649653	-0.549418	0.004027	0.401837	0.000000	0.000000	62.763305	363.32508	90184.305	267.261366
88	0.664643	-0.548380	0.002295	0.409000	0.000000	0.000000	0.000000	346.11565	90293.856	267.354084
89	0.675456	-0.547630	0.001031	0.415000	0.000000	0.000000	0.000000	328.91587	90405.810	267.448753
90	0.682041	-0.547084	0.000260	0.419000	0.000000	0.000000	0.000000	326.47761	90461.049	267.495432
91	0.684944	-0.546944	0.000000	0.421000	0.000000	0.000000	0.000000	326.20741	90421.621	267.461947
92	0.682634	-0.546232	0.000000	0.423000	0.000000	0.000000	0.000000	341.13903	90318.811	267.375193
93	0.705168	-0.545307	0.000000	0.425000	0.000000	0.000000	0.000000	358.09465	90198.654	267.273514
94	0.736144	-0.543615	0.000000	0.427000	0.000000	0.000000	0.000000	333.80412	0.000	0.000000

*** SUBROUTINE LEWICE2D COMPLETE ***

CPU TIME = 1338.289

*** SUBROUTINE BODMOD COMPLETE ***

CPU TIME = 1339.025

Figure 26. - Concluded.

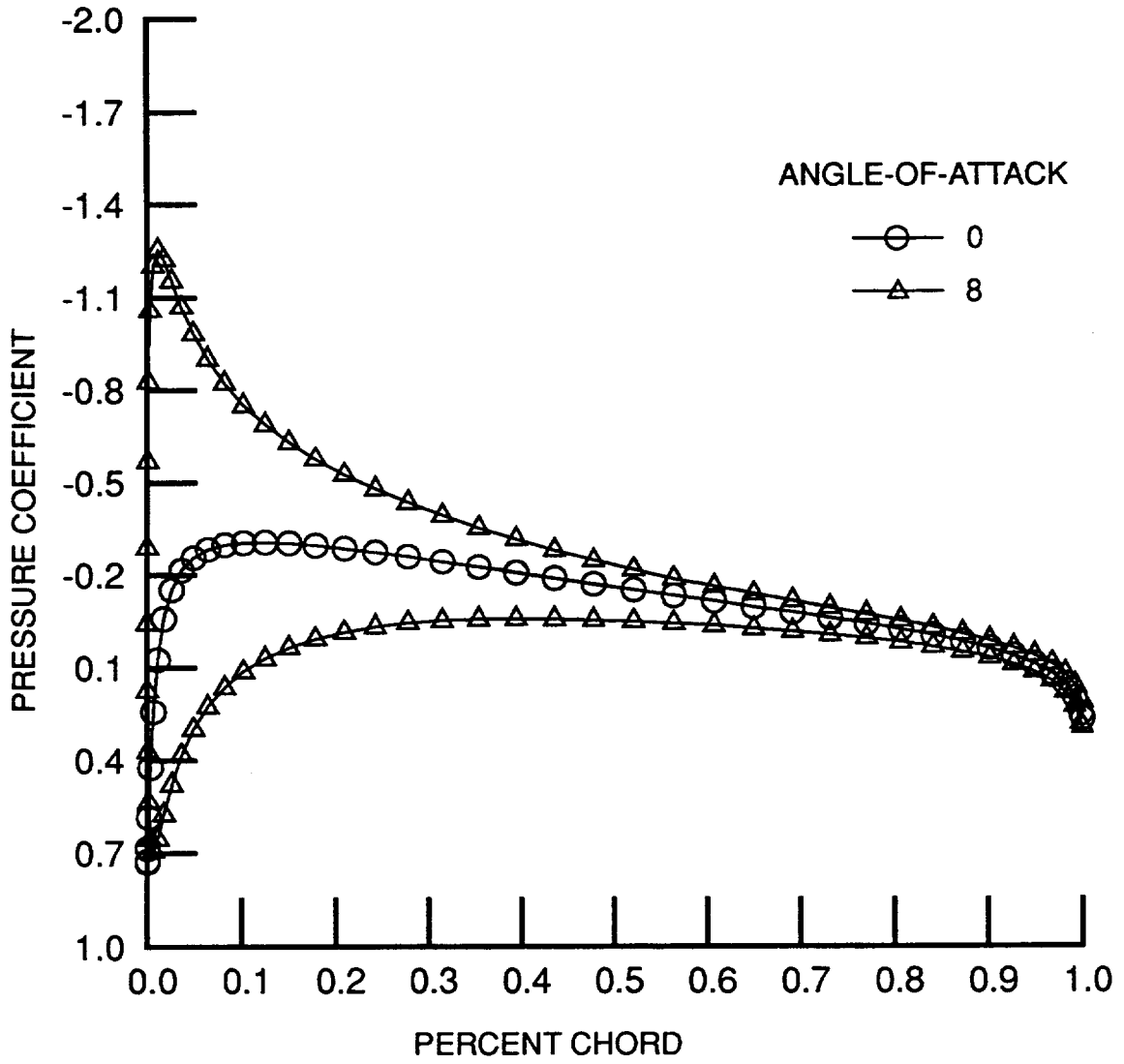

Figure 27. - Pressure distribution at 50% span location for example case at 0 and 8 degrees angle-of-attack.

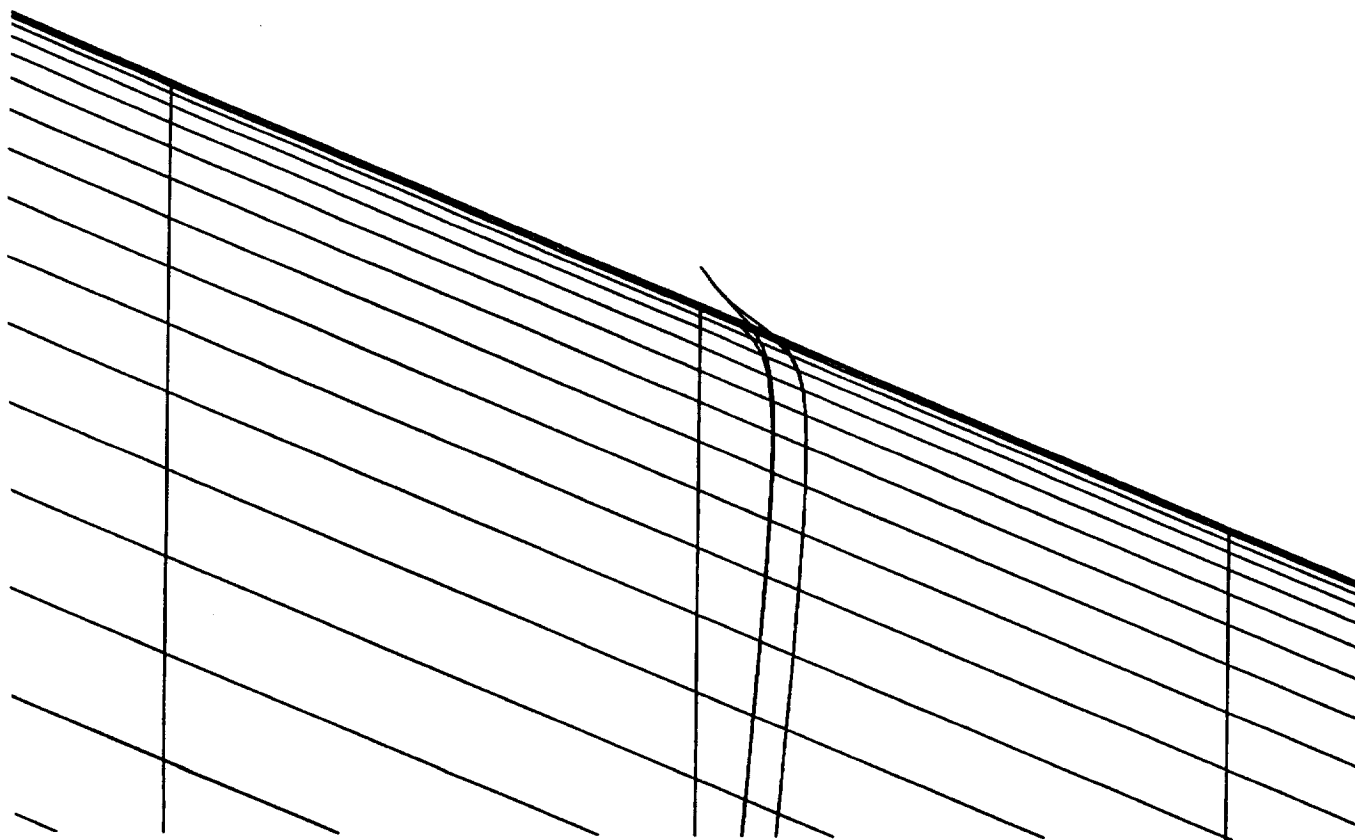

Figure 28. - Illustration of off-body and on-body streamlines.

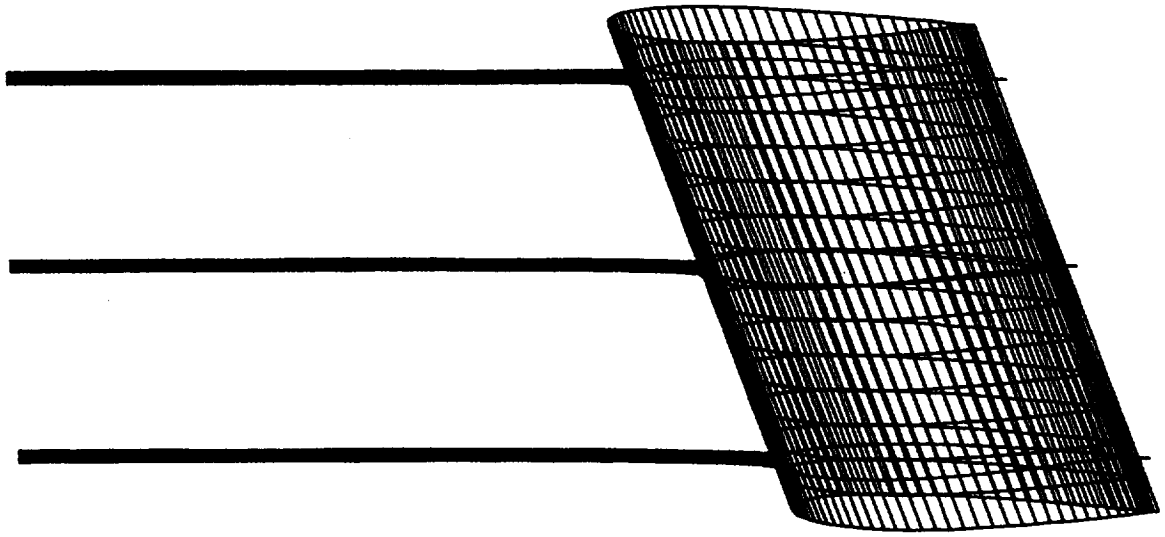

Figure 29. - Illustration of impact trajectories for the example case.

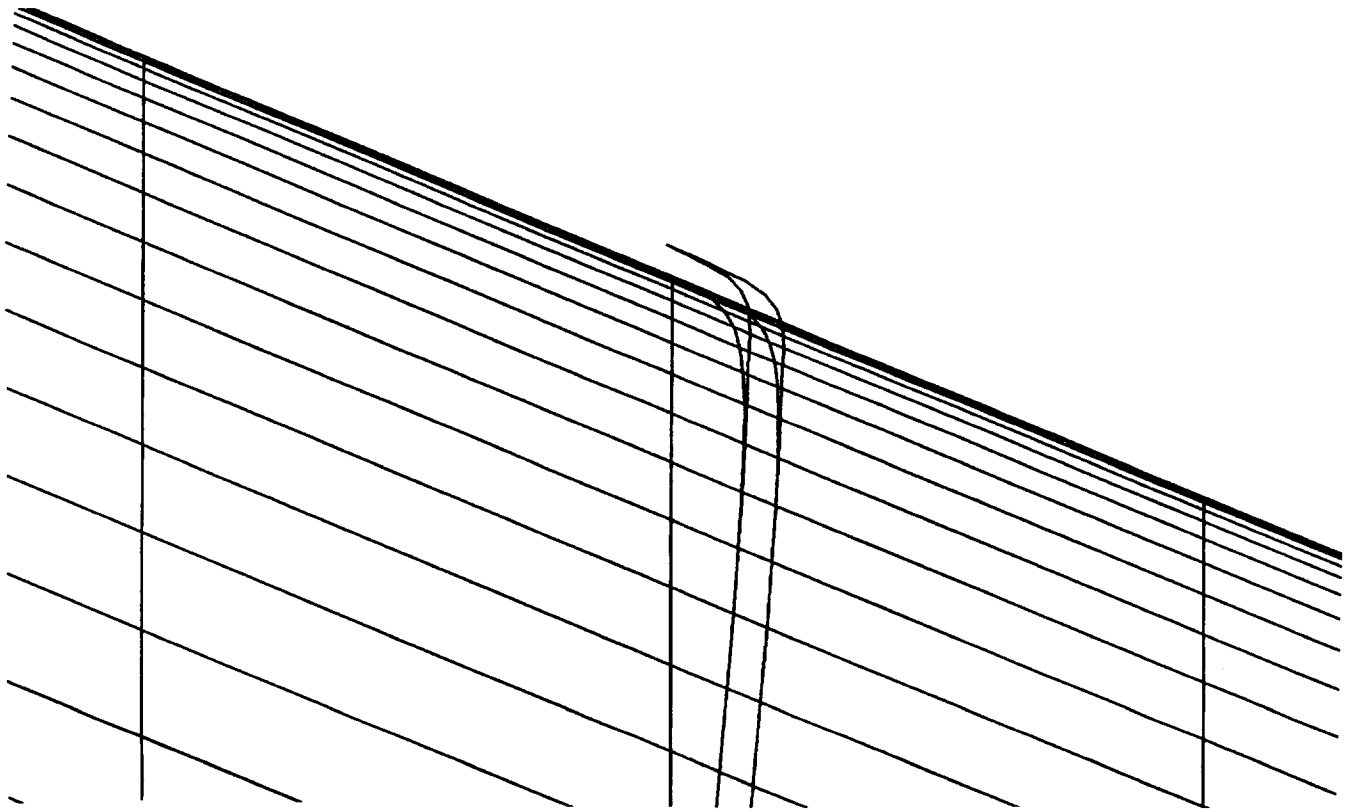

Figure 30. - Illustration of iced streamline for the example case.

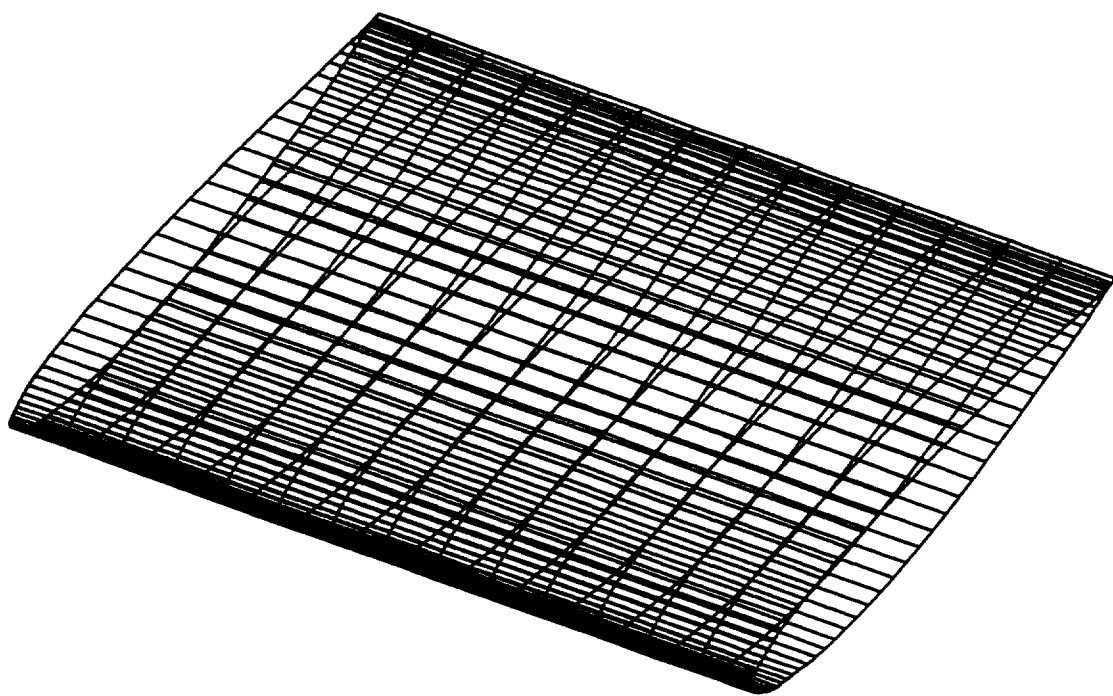

Figure 31. - Iced wing panel model for the example case.

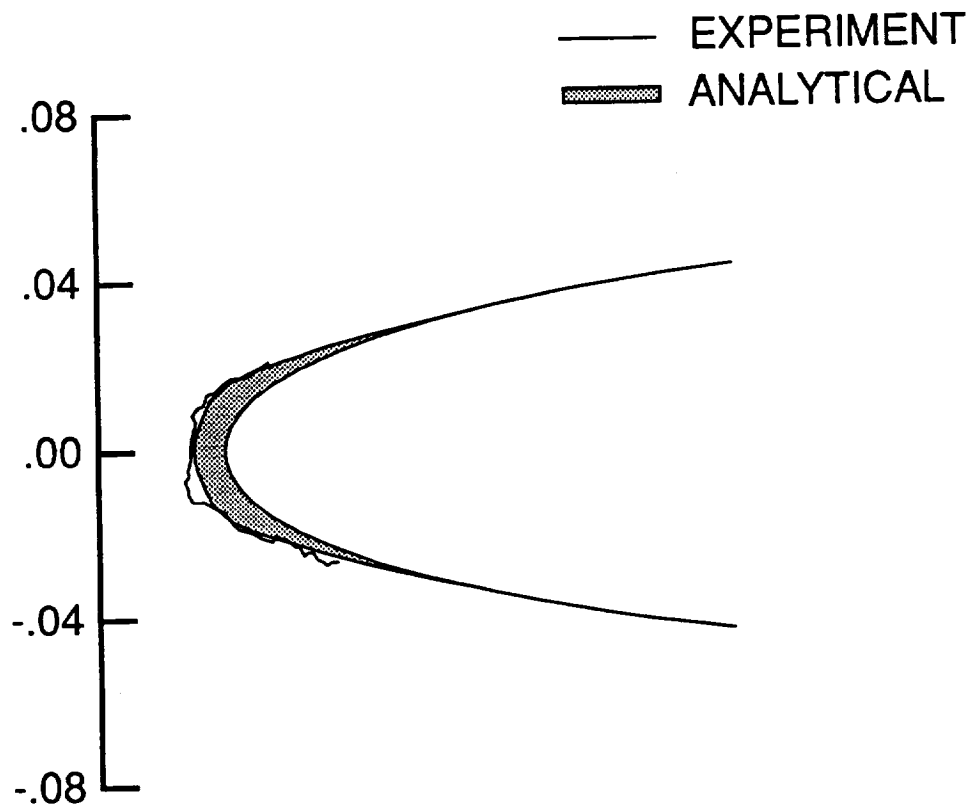

Figure 32. - Comparison of predicted and measured ice shape at the 0% span location for the example case.

REPORT DOCUMENTATION PAGE

Form Approved
OMB No. 0704-0188

Public reporting burden for this collection of information is estimated to average 1 hour per response, including the time for reviewing instructions, searching existing data sources, gathering and maintaining the data needed, and completing and reviewing the collection of information. Send comments regarding this burden estimate or any other aspect of this collection of information, including suggestions for reducing this burden, to Washington Headquarters Services, Directorate for Information Operations and Reports, 1215 Jefferson Davis Highway, Suite 1204, Arlington, VA 22202-4302, and to the Office of Management and Budget, Paperwork Reduction Project (0704-0188), Washington, DC 20503.

1. AGENCY USE ONLY (Leave blank)	2. REPORT DATE December 1993	3. REPORT TYPE AND DATES COVERED Technical Memorandum	
4. TITLE AND SUBTITLE Users Manual for the NASA Lewis Three-Dimensional Ice Accretion Code (LEWICE 3D)		5. FUNDING NUMBERS WU-505-68-10	
6. AUTHOR(S) Colin S. Bidwell and Mark G. Potapczuk			
7. PERFORMING ORGANIZATION NAME(S) AND ADDRESS(ES) National Aeronautics and Space Administration Lewis Research Center Cleveland, Ohio 44135-3191		8. PERFORMING ORGANIZATION REPORT NUMBER E-7847	
9. SPONSORING/MONITORING AGENCY NAME(S) AND ADDRESS(ES) National Aeronautics and Space Administration Washington, D.C. 20546-0001		10. SPONSORING/MONITORING AGENCY REPORT NUMBER NASA TM-105974	
11. SUPPLEMENTARY NOTES Responsible person, Colin S. Bidwell, (216) 433-3947.			
12a. DISTRIBUTION/AVAILABILITY STATEMENT Unclassified - Unlimited Subject Categories 02, 03		12b. DISTRIBUTION CODE	
13. ABSTRACT (Maximum 200 words) A description of the methodology, the algorithms, and the input and output data along with an example case, for the NASA Lewis 3D ice accretion code (LEWICE3D) has been produced. The manual has been designed to help the user understand the capabilities, the methodologies and the use of the code. The LEWICE3D code is a conglomeration of several codes for the purpose of calculating ice shapes on three-dimensional external surfaces. A three-dimensional external flow panel code is incorporated which has the capability of calculating flow about arbitrary 3D lifting and nonlifting bodies with external flow. A 4th order Runge-Kutta integration scheme is used to calculate arbitrary streamlines. An Adams type predictor-corrector trajectory integration scheme has been included to calculate arbitrary trajectories. Schemes for calculating tangent trajectories, collection efficiencies and concentration factors for arbitrary regions of interest for single droplets or droplet distributions have been incorporated. A LEWICE 2D based heat transfer algorithm can be used to calculate ice accretions along surface streamlines. A geometry modification scheme is incorporated which calculates the new geometry based on the ice accretions generated at each section of interest. The three-dimensional ice accretion calculation is based on the LEWICE 2D calculation. Both codes calculate the flow, pressure distribution, and collection efficiency distribution along surface streamlines. For both codes the heat transfer calculation is divided into two regions, one above the stagnation point and one below the stagnation point, and solved for each region assuming a flat plate with pressure distribution. Water is assumed to follow the surface streamlines, hence starting at the stagnation zone any water that is not frozen out at a control volume is assumed to run back into the next control volume. After the amount of frozen water at each control volume has been calculated the geometry is modified by adding the ice at each control volume in the surface normal direction.			
14. SUBJECT TERMS Aircraft icing; Ice accretion prediction		15. NUMBER OF PAGES 143	
		16. PRICE CODE A07	
17. SECURITY CLASSIFICATION OF REPORT Unclassified	18. SECURITY CLASSIFICATION OF THIS PAGE Unclassified	19. SECURITY CLASSIFICATION OF ABSTRACT Unclassified	20. LIMITATION OF ABSTRACT