

## USRP 2901 Based FM Transceiver with Large File Capabilities in Virtual and Remote Laboratory

<https://doi.org/10.3991/ijoe.v14i10.8283>

U. Somanaidu<sup>(✉)</sup>

Institute of Aeronautical Engineering, Hyderabad, India  
somanaidu.409@gmail.com

Nagarjuna Telagam  
GITAM University, Bangalore, India

K. Nehru  
Institute of Aeronautical Engineering, Hyderabad, India

N. Menakadevi  
Hindustan College of Engineering and Technology, Coimbatore, India

**Abstract**—The radio signal processing capability can be provided by Universal software radio peripheral (USRP) hardware. The received signal frequency can be controlled and transmitting the signal through wireless is possible by installing NI USRP utility configuration. The programmable USRP was running VI snippet program in block diagram panel with radio companion integrated through USB cable on windows 7 64 bit OS. With the parameters such as IQ rate, transmitter gain, carrier frequency along with device name which is given as ni2901\_1 the students can able to tune the radio signal. In addition to this the students can able to record the FM signal and extract the IQ data and plot the spectrum of signal and analyze it using graph palette. The standard FM equation contains the modulation index, carrier frequency, message signal amplitude, frequency deviation and frequency sensitivity can also analyzed using LabVIEW. By using Carson's rule the bandwidth of wideband FM signal can be calculated. In this project RF0 module is used USRP device is connected with dual band vertical antenna with 2.4 and 5GHz frequency as Tx1 and the receiver is connected to Tri band vertical antenna with 144, 400 and 1200 MHz. while transmitting red color will blink in the device for transmitting and green color indicates the received signal. The purpose of doing this experiment was to gain experience in signal processing and receive hands on experience with the USRP. This VI snippet program will support all file formats. Up sample we used in front panel should be -1 always and if large size files is transmitted the value should be increased. The iPhone received the signal with high quality using ear pods the students can able to listen all the information which is transmitted through USRP. Here the transmitted frequency we used in the front panel is 94.7 MHz. The transmitted signal through USRP is successfully tested in the campus of Institute of Aeronautical Engineering, Hyderabad, India.

**Keywords**—USRP 2901, FM, LabVIEW, VI, IQ data.

## 1 Introduction

FM broadcasting is a method of [radio broadcasting](#) using [frequency modulation](#) (FM) technology. Invented in 1933 by American engineer [Edwin Armstrong](#), it is used worldwide to provide [high-fidelity](#) sound over broadcast [radio](#) [1]. This paper discusses modulation techniques with the LabVIEW-based RF communications package, developed for the illustration of different modulation types in undergraduate virtual instrumentation labs [2]. Measure the sensor analog data and displayed in LabVIEW on the monitor using the graphical user interface (GUI) [3]. The LabVIEW basic program was taken as reference [4],[5]. One of the advantages that joins having the capacity to get to DAB broadcasting is that not at all like conventional FM radio telecom where you need to recollect the radio station recurrence to tune in, DAB records radio stations by their names in order arrange. What's more, there are additional highlights, for example, radio stations that must be gotten to from DAB radio recipients, which offers even a more extensive scope of radio stations to the audience[6]. Smart Sensor Interface Standard, puts forward the idea of the combination of smart sensor and video, audio signal monitoring [7]. Frequency division multiplexing (FDM) is another popular technique in wireless communication which is famous for the efficient high speed transmission [8]. The modulated carrier contains several spectral components, requiring frequency domain analysis. The key concept and the underlying principle of FM and FM bandwidth dilemma are presented [9]. Software-defined radios (SDRs) promise unprecedented flexibility, but their architecture has proven to be a challenge for MAC protocols [10]. After being the subject of speculation for many years, a software-defined radio receiver concept has emerged that is suitable for mobile handsets. A key step forward is the realization that in mobile handsets, it is enough to receive one channel with any bandwidth, situated in any band. Thus, the front-end can be tuned electronically [11]. LabVIEW interacts with the USRP transmitter by means of four functions located on the block diagram's palette under Hardware Interfaces is taken from this manual [12].

## 2 Implementation

### 2.1 USRP 2901 with Dual Band Vertical Antenna and Tri band Antenna

Connect niUSRP device to computer using USB cable and AC/DC power supply cable. Configuration of niUSRP devices follows, Select Start» All Programs» National Instruments» NI-USRP»NI-USRP Configuration Utility to open the NI-USRP Configuration Utility. Select the Devices tab of the utility. Your device should appear in the list on the left side of the tab, similar to the following figure. If you have multiple devices, verify that you selected the correct device. The device ID of the selected device displays in the Selected Device ID textbox.

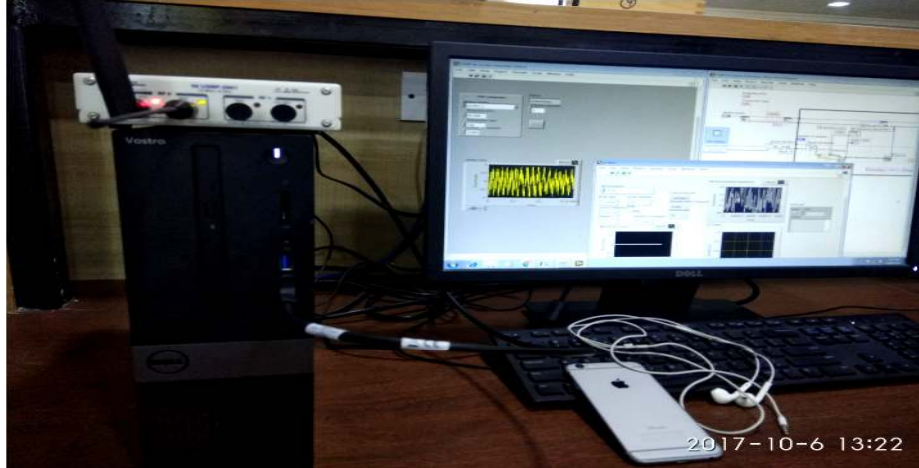

Fig. 1. Experimental set up

## 2.2 Working operation

A basic software defined radio system consists of computer equipped with analog to digital converter preceded by Radio frequency front end. Software radios have significant use for the military and [cell phone](#) services, both of which must serve a wide variety of changing radio protocols in real time. In Fig 1 the red color indicates the signal is transmitting and green color indicates the signal is receiving. The message and carrier signal is represented in equation (1) and (2).  $A_m$  and  $A_c$  are the amplitudes of signal and  $f_m$  and  $f_c$  are the message signal frequency and carrier signal frequency.

$$m(t) = A_m \cos(2\pi f_m t) \quad (1)$$

$$c(t) = A_c \cos(2\pi f_c t) \quad (2)$$

$$s(t) = A_c \cos(2\pi f_c t + \beta \int m(t) dt) \quad (3)$$

$$\text{Bandwidth} = 2(\Delta f + f_m) \quad (4)$$

$$\Delta f = \beta * f_m \quad (5)$$

Equation (3) is the standard FM equation in which  $\beta$  means modulation index, if the value of  $\beta$  is greater than one then it is wideband FM and if the value of  $\beta$  is less than one then it is narrow band FM. Narrow band FM is same as amplitude modulation except side band is shifted to 90 degrees in the frequency domain representation. Equation (4) and (5) shows bandwidth of FM signal according to Carson's Rule where  $\Delta f$  the frequency deviation of FM signal is. The standard value is 75KHz.

**Table 1.** Transmitter parameters

Parameter at Transmitter	Values used
Carrier Frequency	94.7MHz
IQ Rate	5M
Transmitter Gain of the Verto Antenna	5dB
Number of Samples	150000
Digital Gain/ Attenuation	2
Activa Antenna	Tx1

### 3 VI Snippet program using LabVIEW

#### 3.1 FM Transmitter

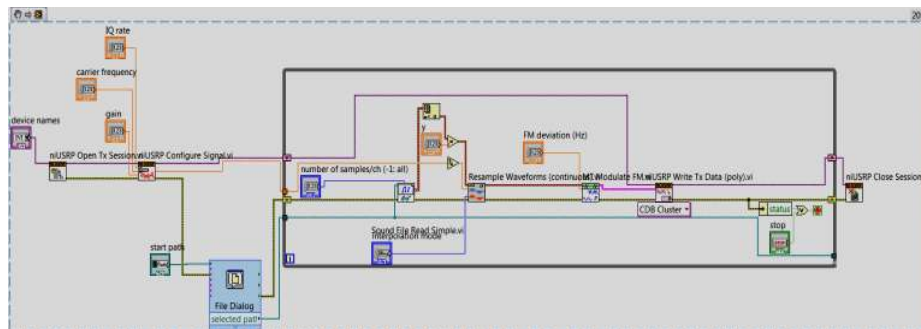

**Fig. 2.** FM Transmitter VI Snippet

Fig 2 explains the block diagram for FM transmitter. Initially niUSRP open Tx session is used to identify the device name. niUSRP Open Transmitter Session opens a transmit session to the devices specify in the device names input and returns session handle out, which you use to identify this instrument session in all subsequent NI-USRP VI's. Device names are niusrp\_01,ni\_2901, niUSRP Property Node VI uses Gets or sets NI-USRP properties. The local oscillator LO Frequency adds IQ rate and carrier frequency of the signal. Next ni USRP configure signal vi is used to give the input carrier frequency and transmitter gain. NiUSRP Configure Signal VI can be used with a transmitter session. It sets the IQ rate, carrier frequency, gain, and active antenna. For multiple USRP configurations the channel list specifies a specific USRP. Not all IQ rates, frequencies and gains are valid. The file dialog is used to select the file from the computer and it is given to sound read vi and then resample it and modulate using MT mod FM and given to CDB Cluster. This entire section is given to while loop to run continuously and at the end ni USRP close session is used to terminate.

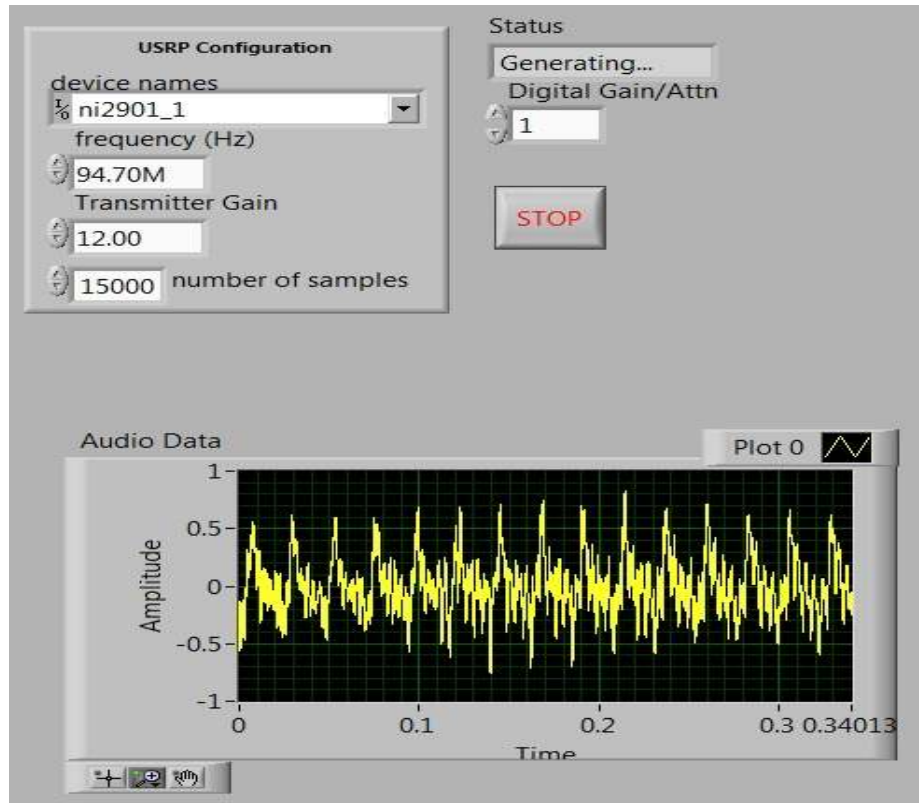

Fig. 3. Front Panel showing the controls and audio data

This VI Snippet supports large file capabilities. For large WAV files, you should choose a value other than -1 for Number of Samples. By adding a multiply function just before the Resample Waveform VI gives the digital gain or digital attenuation to the signal. Values less than 1 will attenuate the signal and values greater than 1 will amplify the signal.

Table 2. Receiver Parameters

Parameter at Receiver	Value used
Carrier Frequency	94.7MHz
IQ Rate	5M
Receiver Gain of the Verto Antenna	20
Number of Samples	15000
Digital Gain/ Attenuation	2
Coerced Gain	30
Coerced Carrier Frequency	25MHz
Coerced IQ Rate	199.999
Active Antenna	Rx1

### 3.2 FM Receiver

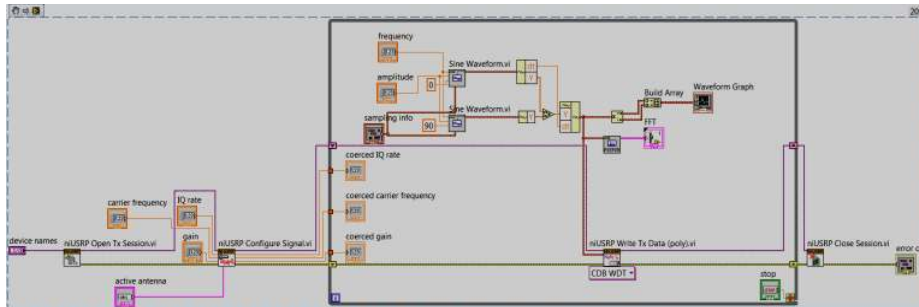

Fig. 4. USRPReceiving Audio Signal

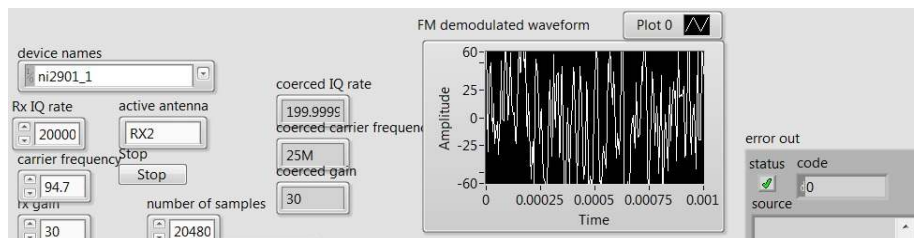

Fig. 5. USRP Receiver Front Panel

## 4 Conclusion

Thus the FM transmitter is designed using USRP 2901 with high quality sound signal transmitting. The intent of writing this paper is to teach some basic digital signal processing tools and RF concepts which includes filtering, sampling rate conversion to students and show them how to use software defined radio to design real time applications. With the assistance of SDR pack, the usage of FM framework turns out to be exceptionally basic since it replaces all equipment that is utilized as a part of the customary correspondence framework with programming. SDR has a great deal of potential for executing the developing remote applications. We exhibited the ease of use of SDR to execute the correspondence framework. The FM Transmitter and Receiver frameworks actualized here give the idea of Software Defined Radio with the assistance of USRP 2901 as an equipment instrument and LabVIEW as a product device. We actualized a correspondence framework with LabVIEW programming with USRP and we effectively transmit the Digital information from USRP load up and got it on the same USRP load up at various time. Consequently obviously one can actualize other correspondence frameworks utilizing SDR and break down the execution. Along these lines utilizing SDR it is conceivable to outline model of the Communication frameworks and conceivable to confirm the ongoing execution of the framework. A ton of research is being done on the SDR in various applications to make it accessible for business utilize

## 5 References

- [1] [https://en.wikipedia.org/wiki/FM\\_broadcasting](https://en.wikipedia.org/wiki/FM_broadcasting)
- [2] Kandasamy, Nehru, et al. "Simulation of Analog Modulation and Demodulation Techniques in Virtual Instrumentation and Remote Lab." *International Journal of Online Engineering (iJOE)* 13.10 (2017): 140-147. <https://doi.org/10.3991/ijoe.v13i10.7575>
- [3] Telagam, Nagarjuna, Nehru Kandasamy, and MenakadeviNanjundan. "Smart Sensor Network Based High Quality Air Pollution Monitoring System Using Labview." *International Journal of Online Engineering (iJOE)* 13.08 (2017): 79-87.
- [4] Telagam, Nagarjuna, et al. "Cruise Control of Phase Irrigation Motor Using SparkFun Sensor." *International Journal of Online Engineering (iJOE)* 13.08 (2017): 192-198. <https://doi.org/10.3991/ijoe.v13i08.7318>
- [5] Telagam, Nagarjuna, et al. "Smart Sensor Network based Industrial Parameters Monitoring in IOT Environment using Virtual Instrumentation Server." *International Journal of Online Engineering (iJOE)* 13.11 (2017): 111-119. <https://doi.org/10.3991/ijoe.v13i11.7630>
- [6] Nagarjuna, T., et al. "Design and Development of Coded OFDM based Digital Audio Broadcasting System using Concatenated Convolutional Turbo Codes."
- [7] Gantala, Anil, et al. "Design of Smart Sensor Using Linux-2.6. 29 Kernel." *International Journal of Applied Engineering Research* 12.18 (2017): 7891-7896.
- [8] Nagarjuna, T., and S. Ganesh. "Design and Development of Hybrid Adaptation Techniques in MimoOfdm System for 4G Wireless Networks." *International Journal of Innovative Research and Development* 2.4 (2013): 533-546.
- [9] Faruque, S. *Radio frequency modulation made Easy*. Springer. (2017). <https://doi.org/10.1007/978-3-319-41202-3>
- [10] Nychis, George, ThibaudHottelier, Zhuocheng Yang, SrinivasanSeshan, and Peter Steenkiste, *Enabling MAC Protocol Implementations on Software-Defined Radios*. In NSDI, 9. (2009):91-105.
- [11] Abidi, Asad A. The path to the software-defined radio receiver. *IEEE Journal of Solid-State Circuits*, 42, 5(2007). 954-966. <https://doi.org/10.1109/JSSC.2007.894307>
- [12] *Lab Based Learning with NI USRP, and LabVIEW Communication Student Lab Manual*, Bruce A. Black

## 6 Authors

**Somanaidu Utlapalli** received his M.Tech. (Engineering) in VLSI and Embedded system from Prakasam Engineering college (PEC), Kandukur – 523105, India in 2014. He is currently an Assistant Professor in the Department of Electronics and Communication Engineering of IARE, Jawarharlal Nehru Technological University, Hyderabad. His research area includes VLSI and Embedded System.

**Mr. T. Nagarjuna** pursued Bachelor of Technology from JNT University, Narayana Engineering College, in 2011 and Master of Engineering from Anna University, Loyola Institute of Technology in year 2013. He is currently pursuing Ph.D. in Sathyabama University and currently working as Assistant Professor in the Department of Electronic and Communication, GITAM University, Bangalore since June 2018. He is a life member of the ISTE since 2018. He has published more than 15 research papers in reputed international journals including Elsevier (SCI & Web of Science) and conferences including Springer and it's also available online. His main research work focuses

on 5G Candidate waveforms, GFDM, OFDM, MIMO, VLSI, and Virtual Instrumentation. He has 5 years of teaching experience and 1 years of Research Experience. He is Anna University rank holder (20) for M.E degree in 2013. He is certified LabVIEW Associate Developer.

**Nehru Kandasamy** received his B.E. (2005, Electronics & Instrumentation) – Erode Sengunthar Engineering College, Erode, Tamil Nadu. He has obtained M.E. (2007, VLSI Design) – R.M.K. Engineering College, Chennai, Tamil Nadu. He has obtained his Ph.D. (2014, Information & Communication) – Anna University, Chennai, Tamil Nadu. He is currently a Professor, Electronics and Communication Engineering Department, Institute of Aeronautical Engineering, Hyderabad. He has published several research papers in refereed/ISC indexed papers in various journals. His research interests include Digital Design, Low Power VLSI and Nanoelectronics with emphasis on QCA computations.

**Menakadevi Nanjundan** is with the Electronics and Communication Engineering Department, Hindustan College of Engineering and Technology, Coimbatore, India. She is a Research Fellow and is interested in the following topics: Digital Image processing, Wireless communications. Currently She is working as assistant professor. Her professional experience is about 5 years in the field of teaching. She completed Master degree M.E - communication system in Loyola institute of technology/AnnaUniversity

Article submitted 22 January 2018. Resubmitted 18 and 30 July 2018. Final acceptance 30 July 2018. Final version published as resubmitted by the authors.