

V/F control of Three Phase Induction Motor Drive with Different PWM Techniques

Gaber El-Saady^{1*} El-Nobi A. Ibrahim^{1,2} Mohamed Elbesealy^{1,3}

1. Electric Engineering Department, Assiut University, Assiut, Egypt

2. Electric Engineering Department, Assiut University, Assiut, Egypt

3. Electric Engineering Department, Assiut University, Assiut, Egypt

* gaber1@yahoo.com

Abstract

This paper presents a v/f control of induction motor with different pulse width modulation (PWM) techniques as sine triangle pulse width modulation (SPWM), Third-harmonic pulse width modulation (THPWM) and Space vector pulse width modulation(SVPWM) using MATLAB SIMULINK. Induction motor modeled in the synchronous q-d reference frame. The performance of IM with full load torque is compared using these techniques for THD, harmonics spectra, utilization of dc supply voltage, fundamental peak of the output voltage and motor speed. The dynamic performance of IM using SVPWM under reference speed and load torque variations is studied also. The results show that the SVPWM is the efficient one because it's superior performance characteristics. The operation of IM with v/f method for closed loop system is enhancement when SVPWM technique is applied.

Keywords: Space vector modulation, SPWM, V/f control, Harmonic injection.

1. Introduction

Among all types of ac machine, the induction machine especially the cage type, is the most commonly used in industry. These machines have merits as economical, rugged, and reliable and are available in the ranges of fractional horse power to multi –megawatt capacity (Bose 2011). the induction motor has two inherent limitations: (1) the standard motor is not a true constant –speed machine, its full load slip varies from less than 1% (in high horse power)to more than 5%(in fractional-horsepower) .(2) it is not , inherently capable of providing variable speed operation . A closed-loop speed control with constant v/f method is implemented when accuracy in speed response is a concern as shown in Fig.1 .A PI controller is employed to regulate the slip speed of the motor to keep the motor speed at its set value (Ogbuka *et al* .2009).

A pulse width modulated inverter(PWM) employing pure sinusoidal modulation ,can't provide sufficient voltage to enable a standard motor to operate at rated values .Sufficient voltage can be obtained from the inverter by over-modulating , however this produce distortion of the output waveform. The necessary increase in voltage can be obtained without Resort to over-modulation and without distortion of the line-to-line output voltage waveform by using third harmonic injection. By addition of 17% third harmonic component to the original sine reference wave form the resulting flat-topped waveform allows over-modulation (with respect to the Original sine PWM technique) while maintaining excellent fundamental peak value(Houldsworth *et al* .1984).

Space Vector Pulse Width Modulation (SVPWM) is a form of Pulse Width Modulation (PWM) Suggested in mid 1980s which was claimed to be more efficient compared to natural and regular sampled PWM. SVPWM has been the subject research interest in further the efficiency; hence, many works have been done especially in improving the algorithm and hardware implementation (Nazlee *et al* 2010). It gives 15% more output voltage then conventional modulation, i.e. better DC-link utilization and More efficient use of DC supply voltage. SVPWM is the best among all the PWM techniques for variable frequency drive application. Because of its superior performance characteristics, it has been finding widespread application in recent years (Arulmozhiyal & Baskaran 2009).

A comparison between SPWM and SVPWM techniques is done for THD, harmonic, dc bus utilization and output voltage of v/f control of induction motor for both open loop and closed loop systems (Swamy & Kumar 2009).

In this paper a comparison between the three techniques SPWM, THPWM and SVPWM with v/f closed loop speed control of three phase induction motor, the modulation index, dc bus voltage and switching frequency will be the

same for all types .the main points of comparison are THD, harmonics spectra, dc utilization, fundamental peak of the output voltage and motor speed. The dynamic performance of IM using SVPWM under reference speed variation and load torque variation is studied also.

2. Space vector modulation

Space vector modulation (SVM) is quite different from the PWM methods .SVM treats the inverter as a single unit; specifically, the inverter can be driven to eight unique states as shown in Table. I. Modulation is accomplished by switching the state of the inverter .The control strategies are implemented in digital system .The objective is to generate PWM load line voltage that are in average equal to a given (or reference) load line voltage .This is done in each sampling period by properly selecting the switch states of the inverter and calculation of the appropriate time period for each state .The selection of the states and their time periods are accomplished by the space vector transformation (Rashid 1993).

The circuit model of a typical three-phase voltage source PWM inverter is shown in Fig.2. S1 to S6 are the six power switches that shape the output voltage. It has been shown to generate less harmonic distortion in the output voltages and or currents applied to the phases of an AC motor and to provide more efficient use of supply voltage compared with sinusoidal modulation technique as shown in Fig.3. As a result, six non-zero vectors and two zero vectors are possible. Six nonzero vectors (V1 - V6) shape the axes of a hexagonal as depicted in Fig.4, and feed electric power to the load. The angle between any adjacent two non-zero vectors is 60 degrees. Meanwhile, two zero vectors (V0 and V7) are at the origin and apply zero voltage to the load (Woo Jung & Keyhani 2005).

Note that the respective voltage should multiplied by Vdc.

The space vector PWM is realized based on the following steps (Woo Jung & Keyhani 2005):

- Step 1. Determine Vd, Vq, Vref, and angle (α)
- Step 2. Determine time duration T1, T2, T0
- Step3.Determine the switching time of each transistor (S1 to S6)

A. Determine Vd, Vq, Vref, and angle (α):

From Fig.5, the Vd, Vq, Vref, and angle (α) can be determined as follows:

$$\begin{bmatrix} V_d \\ V_q \end{bmatrix} = \frac{2}{3} \begin{bmatrix} 1 & -\frac{1}{2} & -\frac{1}{2} \\ 0 & \frac{\sqrt{3}}{2} & -\frac{\sqrt{3}}{2} \end{bmatrix} \begin{bmatrix} V_{an} \\ V_{bn} \\ V_{cn} \end{bmatrix} \quad (1)$$

$$|\overline{V_{ref}}| = \sqrt{V_d^2 + V_q^2} \quad (2)$$

$$\alpha = \tan^{-1} \left(\frac{V_q}{V_d} \right) = \omega t = 2\pi f t \quad (3)$$

Where f=fundamental frequency

B. Determine time duration T1, T2, T0:

From Fig.6, the switching time duration can be calculated as follows:

Switching time duration at any Sector

$$T_1 = \frac{\sqrt{3} \cdot T_z \cdot |\overline{V_{ref}}|}{V_{dc}} \left(\sin \frac{n}{3} \pi \cos \alpha - \cos \frac{n}{3} \pi \sin \alpha \right) \quad (4)$$

$$T_2 = \frac{\sqrt{3} \cdot T_z \cdot |\overline{V_{ref}}|}{V_{dc}} \left(-\cos \alpha \sin \frac{n-1}{3} \pi + \sin \alpha \cos \frac{n-1}{3} \pi \right) \quad (5)$$

Where

$$T_z = \frac{1}{f_z}$$

n = 1 through 6 (that is, Sector 1 to 6)

0 < α < 60

$$\therefore T_0 = T_z - (T_1 + T_2) \quad (6)$$

C. Determine the switching time of each transistor (S1 to S6):

Fig.7 shows space vector PWM switching patterns at sector 1 and 2 for example.

The switching time at each sector is summarized in Table .II, and it will be built in Simulink model to implement SVPWM.

3. Third Harmonic Modulation

The idea of Sine plus 3rd harmonic modulation technique is based on the fact that the 3-phase inverter-bridge feeding a 3-phase ac load does not provide a path for zero-sequence component of load current. The THPWM technique is a modification over the SPWM technique wherein intentionally some amount of third harmonic voltage is added to the reference voltage waveform. Now, the resultant waveform (modified modulating signal) is compared with the high frequency triangular carrier waveform as shown in Fig.8. The output of comparator is used for controlling the inverter switches exactly as in SPWM inverter. The advantage of adding small amount of third harmonic in the modulating waveform is that it brings down the peak magnitude of the resultant modulating waveform. The modified modulating waveform appears more flat topped than its fundamental component (Rashid 1993), (Sengupta *et al.* 2013) . The analytical expression for the reference waveform is:

$$y = K \left(\sin(\omega t) + \frac{1}{6} \sin(3\omega t) \right) \quad (7)$$

Where K is a factor for increasing the amplitude. The addition of one-sixth of third harmonic produce a 15.5 % increase in the amplitude of the fundamental of the phase voltage waveform, therefore the third harmonic PWM provide better utilization of the dc supply voltage than the SPWM (Boost & Ziogas 1988).

4. Mathematical Model of Induction Motor

Driving the model equations can be generated from the dq0 equivalent circuit of the induction machine shown in Fig .9. The flux linkages equations associated with this circuit can be found as follows [1], [13-14]:

$$\frac{d\psi_{qs}}{dt} = \omega_b \left(V_{qs} - \frac{R_s X_{rr}}{D} \psi_{qs} - \frac{\omega_e}{\omega_b} \psi_{ds} + \frac{R_s X_m}{D} \psi_{qr} \right) \quad (8)$$

$$\frac{d\psi_{ds}}{dt} = \omega_b \left(V_{ds} + \frac{\omega_e}{\omega_b} \psi_{qs} - \frac{R_s X_{rr}}{D} \psi_{ds} + \frac{R_s X_m}{D} \psi_{dr} \right) \quad (9)$$

$$\frac{d\psi_{qr}}{dt} = \omega_b \left(V_{qr} + \frac{R_r X_m}{D} \psi_{qs} - \frac{R_r X_{ss}}{D} \psi_{qr} - \frac{\omega_e - \omega_r}{\omega_b} \psi_{dr} \right) \quad (10)$$

$$\frac{d\psi_{dr}}{dt} = \omega_b \left(V_{dr} + \frac{R_r X_m}{D} \psi_{ds} + \frac{\omega_e - \omega_r}{\omega_b} \psi_{qr} - \frac{R_r X_{ss}}{D} \psi_{dr} \right) \quad (11)$$

Where

$$D = X_{ss}X_{rr} - X_m^2 \quad (12)$$

$$X_{ss} = X_{ls} + X_m \quad (13)$$

$$X_{rr} = X_{lr} + X_m \quad (14)$$

Then substituting the value of the flux linkages to find the currents:

$$i_{qs} = \frac{X_{rr}}{D} \psi_{qs} - \frac{X_m}{D} \psi_{qr} \quad (15)$$

$$i_{ds} = \frac{X_{rr}}{D} \psi_{ds} - \frac{X_m}{D} \psi_{dr} \quad (16)$$

$$i_{qr} = \frac{-X_m}{D} \psi_{qs} + \frac{X_{ss}}{D} \psi_{qr} \quad (17)$$

$$i_{dr} = \frac{-X_m}{D} \psi_{ds} + \frac{X_{ss}}{D} \psi_{dr} \quad (18)$$

Then the torque and rotor speed can be determined as follows:

$$T_e = \frac{3}{2} \left(\frac{p}{2} \right) \frac{1}{w_r} (\psi_{ds} i_{qs} - \psi_{qs} i_{ds}) \quad (19)$$

$$w_r = \int \frac{p}{2j} (T_e - T_l) \quad (20)$$

Where P: number of poles; J: moment of inertia (Kg/m²). For squirrel cage induction motor, the rotor voltages V_{qr} and V_{dr} in the flux equations are set to zero since the rotor cage bars are shorted..

5. Simulation

Simulation were carried out for constant v/f control of three phase induction motor using SPWM, THPWM and SVPWM techniques for closed loop system with full load torque, the modulation index, switching frequency and dc bus voltage are constant .The model of IM, SPWM, SVPWM and THPWM are build in matlab Simulink and the parameter of motor used is shown in Appendix I.

5.1 V/f control with closed loop and full load torque.

Fig .10 and Fig.11 shows the speed and the stator flux of three types of modulation for IM with closed loop system respectively, at full load torque. Keeping the modulation index equal to 0.7 and switching frequency equal to 1500 HZ for all types. Table III compares the various performance details of SPWM/SVPWM/THPWM Inverter fed IM. Fig.12 and Fig.13 shows the variation of total harmonic distortion and fundamental peak of the output voltage with modulation index variation respectively. Fig.14, Fig.15 and Fig.16 shows the FFT analysis of output voltage for three types. The results show the SVPWM give lower harmonic distortion hence better output voltage.

5.2 Dynamic performance under reference speed variation.

The performance of induction motor with SVPWM is studied with reference speed variation at no load condition.

5.2.1 Effect of a step change in reference speed.

The speed reference is changed from 30 HZ to 60 HZ at load torque T_L=0 N.m, the effect on electrtomechanical torque produced by motor is shown in Fig.17 while the effect on motor speed is shown in Fig.18.

5.2.2 Effect of reversal in speed reference.

By change the speed according to the sequence [0 60 -60 0] the rotor speed of motor is shown in Fig.19 and the electromechanical torque shown in Fig.20. As shown in curves the transient response need a time to settle at given reference speed .

5.3 Dynamic performance under load torque variation

5.3.1 Sequential changes in load torque at reference speed of 60 HZ.

By change the load torque with sequence [0 20 10 20 0]Nm at reference speed of 60 HZ .Fig.21 shows the speed changes due to sequence change in torque ,while Fig.22 shows the change in electromechanical torque due to sequence change In load .

5.3.2 Step change in load torque at a reference speed of 25 HZ.

By change the load torque from 0 Nm to full load torque 20 N.m, Fig.23 and Fig.24 shows the electromechanical torque and rotor speed respectively due to change in torque at reference speed 25 HZ.

6. Conclusions

- 1- The V/f control of Induction motor drive for closed loop system with SVPWM, SPWM and THPWM has been simulated using MATLAB SIMULINK.
- 2- The three PWM Techniques are compared in terms of THD, harmonic spectra, speed, and fundamental peak of output voltage and dc bus utilization.
- 3- It is observed that the SVPWM is the most efficient one because it produced less harmonic distortion in output voltage and higher dc supply utilization aside from complete digital implementation by a single-chip microprocessor.
- 4- The performance of IM is improved when SVPWM technique is applied.
- 5- The THPWM technique gives higher performance than SPWM technique when applied to induction motor.
- 6- The variations in motor speed and torque due to sudden change in reference speed and load torque are observed as expected.

7. Appendix

The Parameters of 3-phase IM That we Used in Simulation are Shown in The Table Below.

Rated Voltage	460 V
Rated frequency	60 HZ
Number of poles	4
Rated Speed	1750 rpm
Stator Resistance	1.115 ohm
Rotor Referred Resistance	1.083 ohm
Stator Reactance	2.2521 ohm
Rotor Referred Reactance	2.2521 ohm
Magnetizing Reactance	76.7931 ohm
Moment of inertia	0.02 Kg .m ²
Winding Connection	Star

References

Bimal K .Bose, (2011), “Modern Power Electronic and Ac Drives”, Prentice-Hall PTR, Book, pp .29-30 and pp56-73.

C.U. Ogbuka, M.Eng. And M.U. Agu. (2009), “A Modified Closed Loop V/F Controlled Induction Motor Drive “The Pacific Journal of Science and Technology, Volume 10. Number 1.

John A. Houldsworth and Duncan A. Grant. (1984), “The Use of Harmonic Distortion to Increase the Output Voltage of a Three-Phase PWM Inverter”, IEEE Transaction On Industry Application, Vol.IA-20, No.5.

Anas Mohd Nazlee, Nor Hisham Hamid, Fawnizu Azmaid Hussin, and Noohul Basheer Zain Ali. (2010), “Space Vector PWM for PMSM Simulation Using Matlab Simulink “, IEEE Trans.

R. Arulmozhiyal, and K. Baskaran.(2009), “Space Vector Pulse Width Modulation Based Speed Control of Induction Motor using Fuzzy PI Controller, ”International Journal of Computer and Electrical Engineering, Vol. 1, No. 1,1793-8198.

R. Linga Swamy and P. Satish Kumar. (2008), “Speed Control of Space Vector Modulated Inverter Driven Induction Motor”, Proceedings of the International MultiConference of Engineers and Computer Scientists Vol II, Hong Kong.

Mohamed H. Rashid.(1993),“power Electronic: Circuit, Devices and Application “Prentice-Hall,Inc, Englewood Cliffs, Book, Second Edition, pp 268-270 and pp271-278 .

Mohan Ned, Undeland Tore M. and Robbins William P.(1995),“Power Electronics, converters and Applications and Design”, John Wiley& Sons, Inc.,Book.

Jin-Woo Jung and Ali Keyhani. (2005), “Project No 2 Space Vector PWM Inverter “The Ohio State University.

Sabyasachi Sengupta, N.K. De, D.Prasad and D.Kastha. (2013), “Power electronic course“, [Online] Available: http://www.nptel.iitm.ac.in/courses/Webcourse-contents/IIT%20Kharagpur/Power%20Electronics/New_index1.html. IIT Kharagpur.

Michael A. Boost and Phoivos D Ziogas. (1988),” State-of-the-Art Carrier PWM Techniques: A Critical Evaluation,”IEEE Trans on Industry Application, VOL. 24, NO. 2.

Burak Ozpineci and Leon M.Tolbert. (2003), “Simulink Implementation of Induction Machine Model – A Modular Approach”, IEEE Trans.

Haitham Abu-Rub, Atif Iqbal and Jaroslaw Guzinski.(2012),“High Performance Control of AC Drives with Matlab/Simulink Models” ,A John Wiley &Sons,Ltd.,Publication,Book,first edition,pp 25-32.

C. M. Ong. (1998), “Dynamic Simulation of Electric Machinery Using Matlab /Simulink”, Prentice-Hall, PTR, Book, pp 172-192.

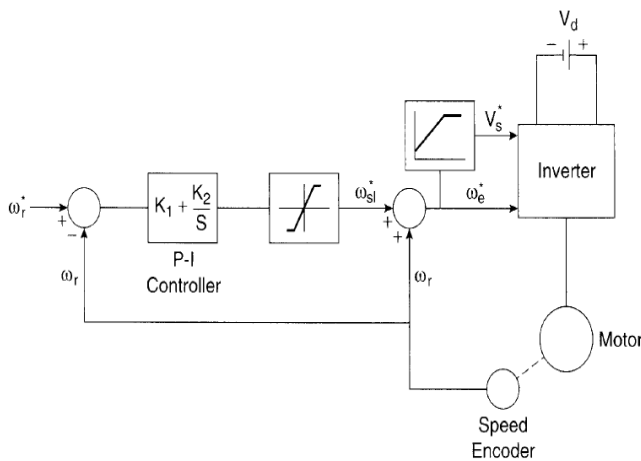

Figure 1. Closed-Loop Speed Control Scheme with Volts/Hertz and Slip Regulation

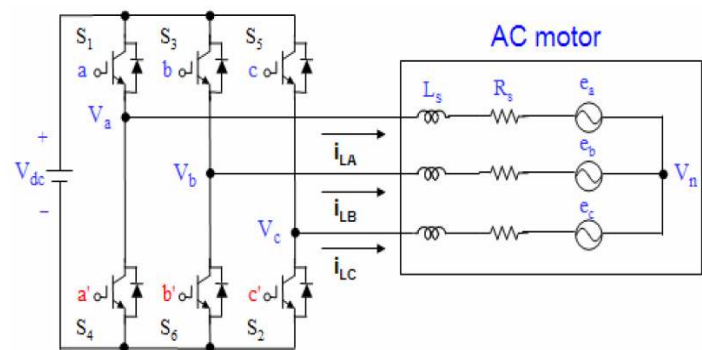

Figure 2.Three Phase Voltage Source PWM Inverter

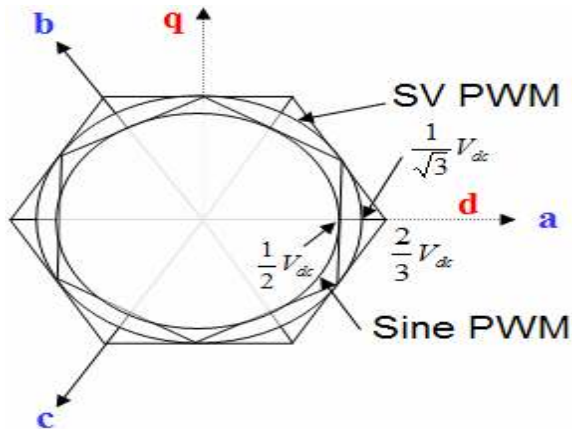

Figure 3. Locus Comparison of Maximum Linear Control Voltage in Sine PWM and SVPWM

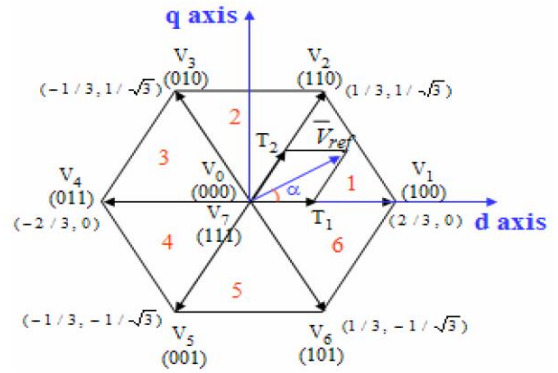

Figure 4. Basic Switching Vectors and Sectors

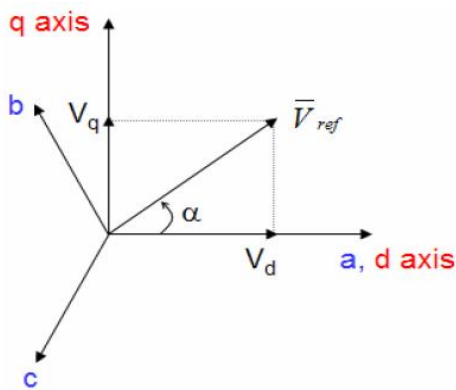

Figure 5. Voltage Space Vector and its Components in (d, q)

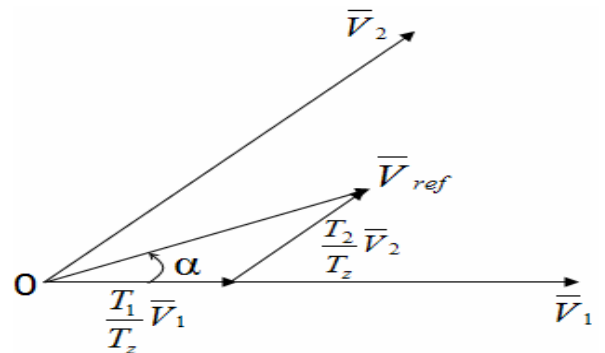
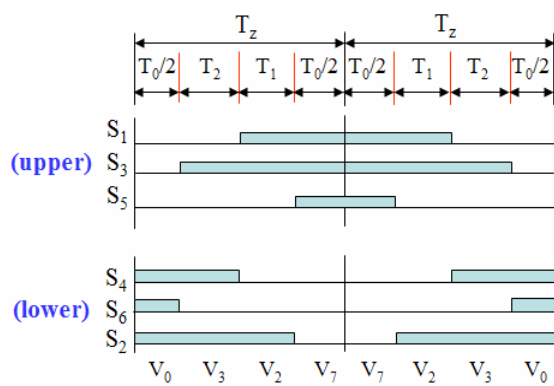
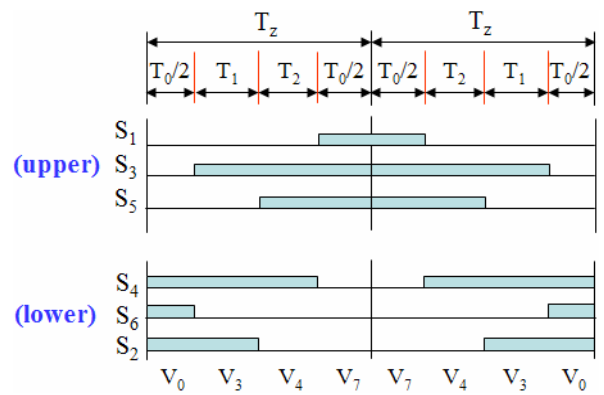

Figure 6. Reference Vector as a Combination of Adjacent Vectors at Sector 1



(a) Sector 1



(b) sector 2

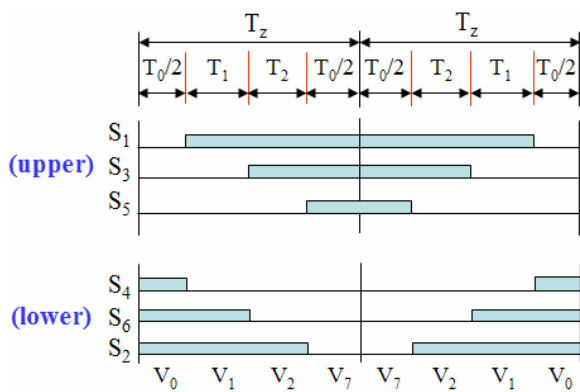

(c) Sector 3.

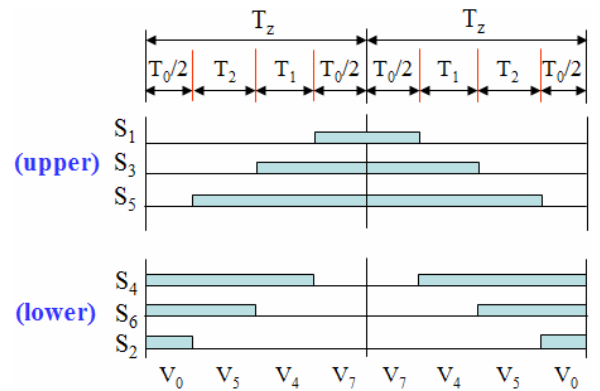

(d) Sector 4.

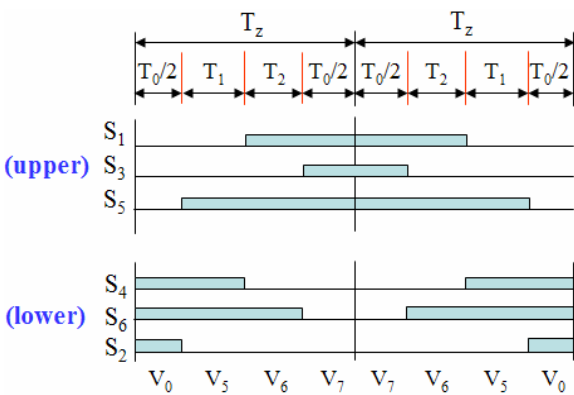

(e) Sector 5.

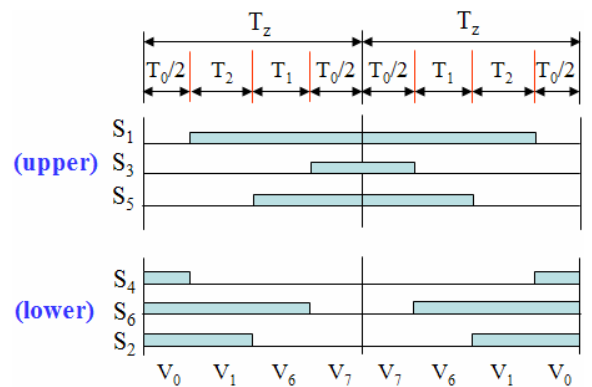

(f) Sector 6.

Figure 7. Space Vector PWM Switching Patterns at Each Sector

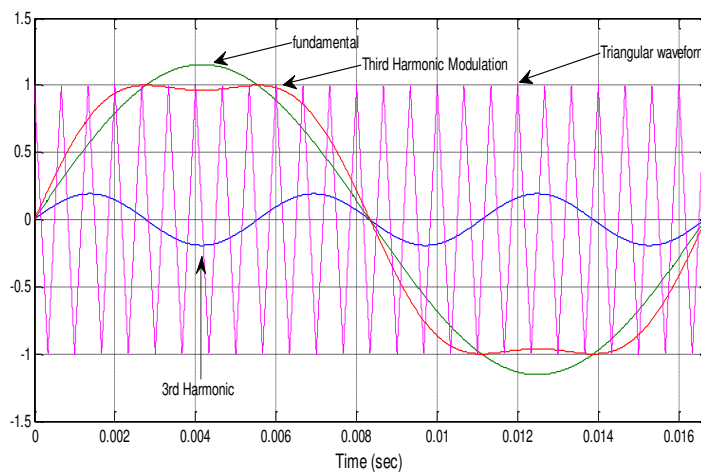
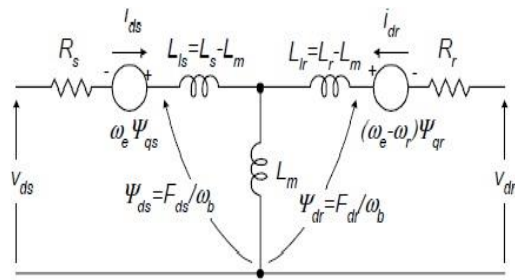
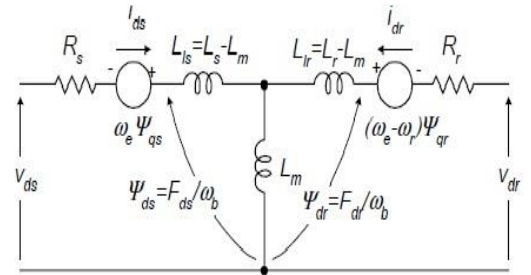

Figure 8. Increasing Fundamental Output Voltage by Addition of Third Harmonic



(a)



(b)

Figure 9. Dynamic d^e-q^e Equivalent Circuits of Machine (a) q^e Axis Circuit (b) d^e Axis Circuit

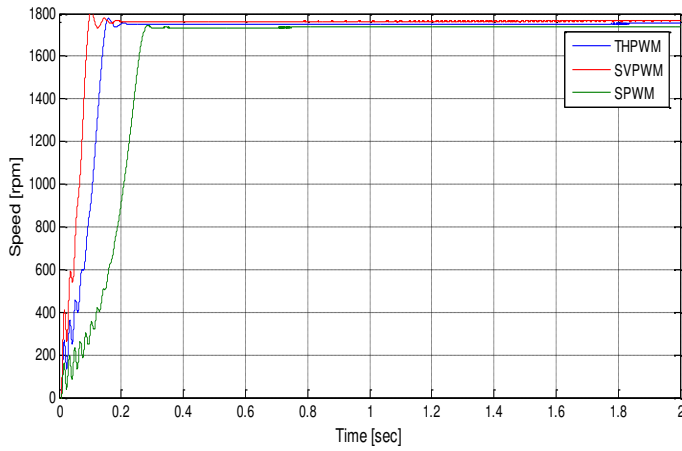

Figure 10. Rotor Speed of IM for Three Types of Modulation

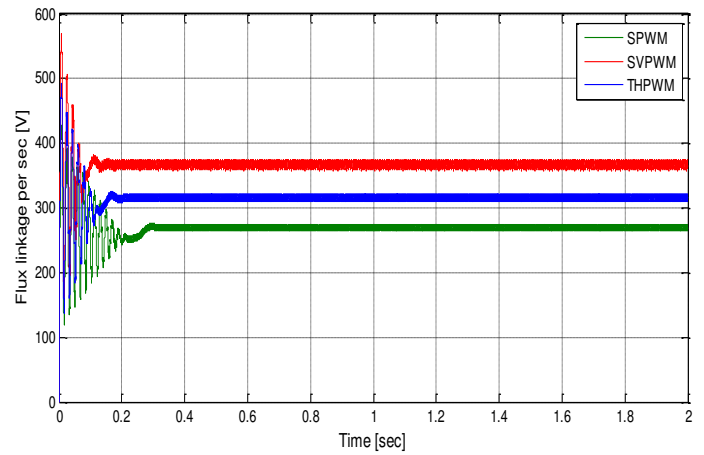

Figure 11. Stator Flux of IM for Three Type of Modulation

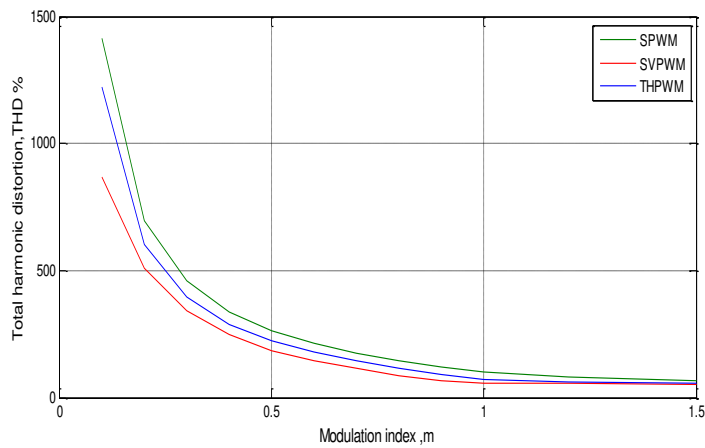

Figure 12. Total Harmonic Distortion with Modulation Index Variation

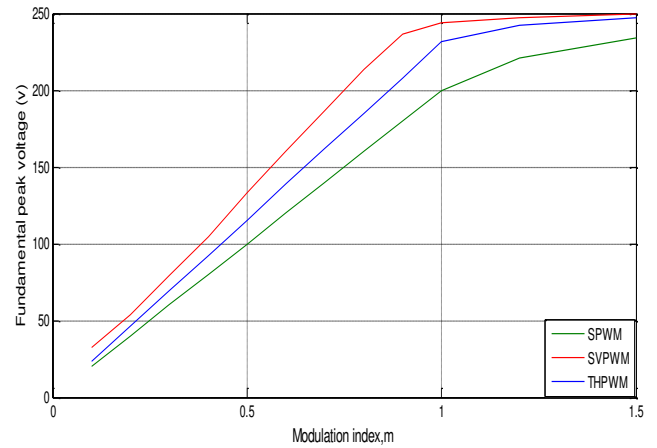

Figure 13. Fundamental Peak of the Output Voltage with Modulation Index Variation

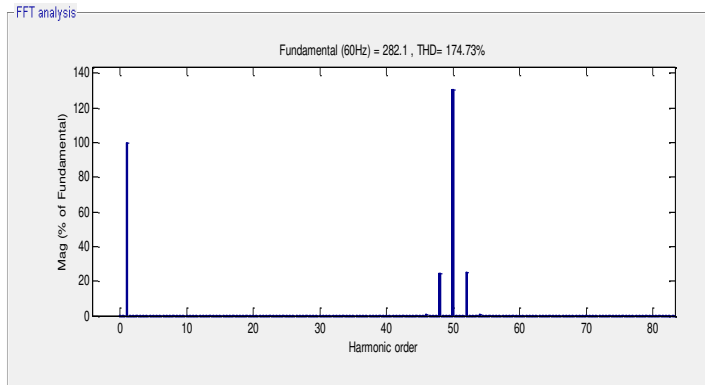

Figure 14. FFT Analysis of Output Phase Voltage in Case of SPWM Technique

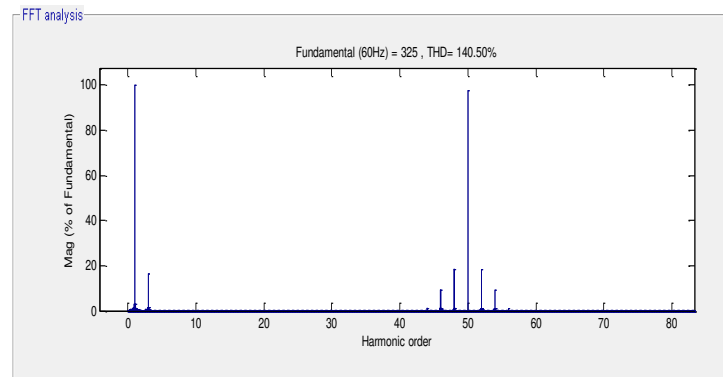

Figure 15. FFT Analysis of Output Phase Voltage in Case of SVPWM Technique

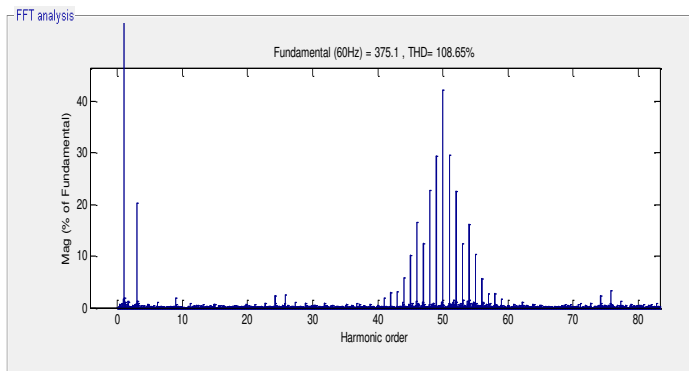

Figure 16. FFT Analysis of Output Phase Voltage in Case of THPWM Technique

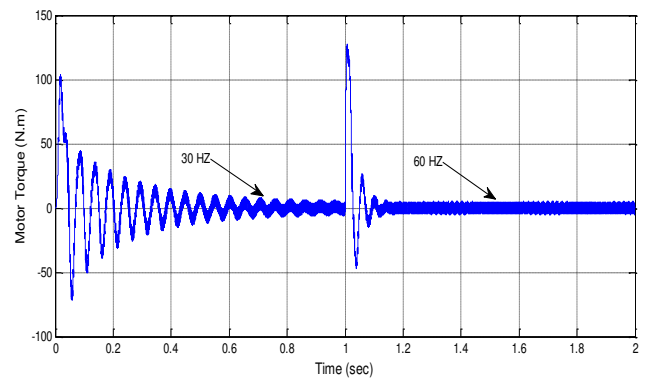

Figure 17. Electromechanical Torque for Step Change in Reference Speed

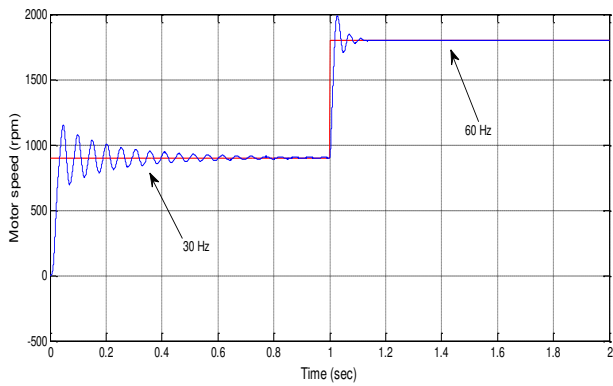

Figure 18. Rotor Speed for Step Change in Reference Speed

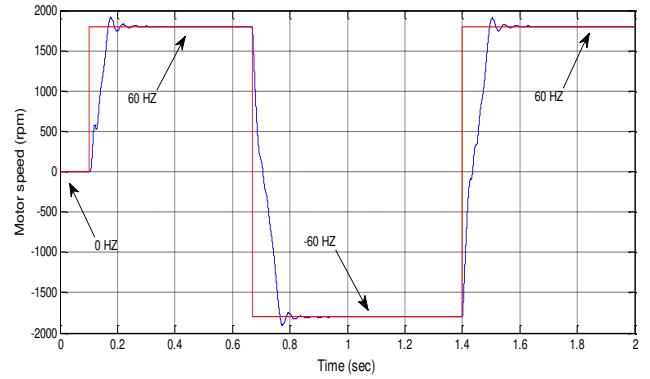

Figure 19. Speed Reversal Due to Change in Speed Reference

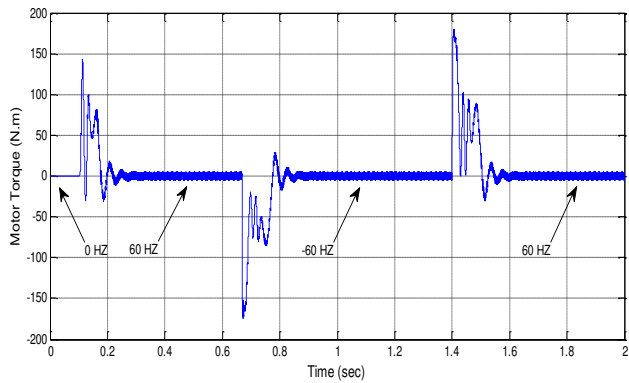

Figure 20. Electromechanical Torque Due to Change in Speed Reference

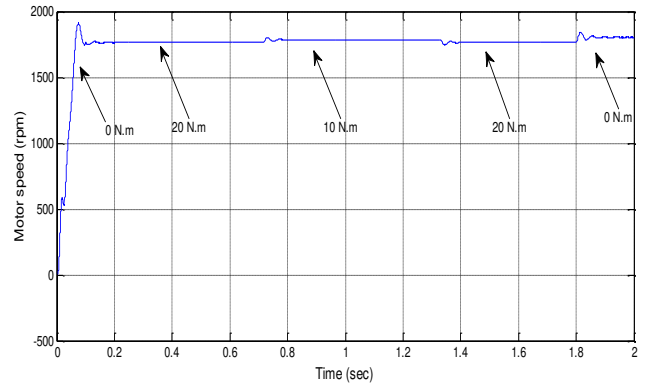

Figure 21. Rotor Speed Due to Sequential Change in Load Torque

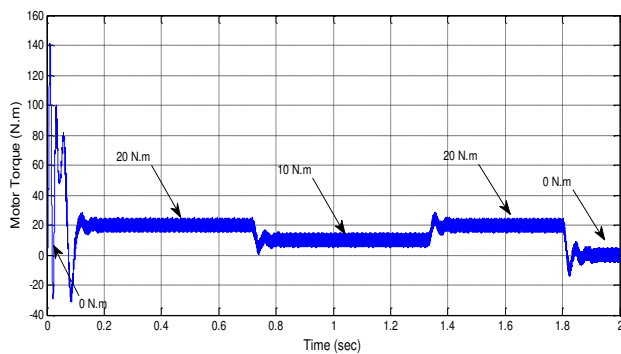

Figure 22. Electromechanical Torque Due to Sequential Change in Load

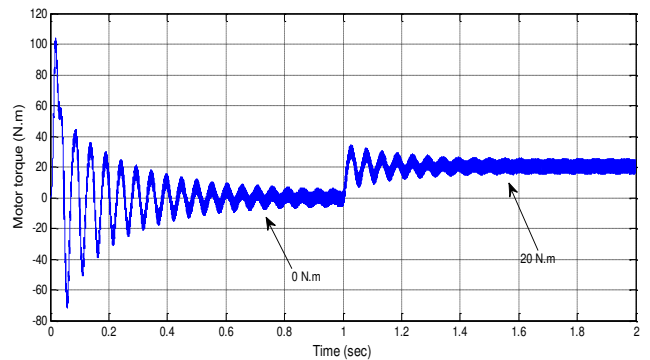

Figure 23. Electromechanical Torque Due to Step Change in Load Torque

Table 1. Switching Vectors, Phase Voltages and Output Line to Line Voltages

Voltage Vectors	Switching Vectors			Line to neutral voltage			Line to line voltage		
	a	b	c	V_{an}	V_{bn}	V_{cn}	V_{ab}	V_{bc}	V_{ca}
V_0	0	0	0	0	0	0	0	0	0
V_1	1	0	0	2/3	-1/3	-1/3	1	0	-1
V_2	1	1	0	1/3	1/3	-2/3	0	1	-1
V_3	0	1	0	-1/3	2/3	-1/3	-1	1	0
V_4	0	1	1	-2/3	1/3	1/3	-1	0	1
V_5	0	0	1	-1/3	-1/3	2/3	0	-1	1
V_6	1	0	1	1/3	-2/3	1/3	1	-1	0
V_7	1	1	1	0	0	0	0	0	0

Table 2. Switching Time Calculation at Each Sector

Sector	Upper Switches (S_1, S_3, S_5)	Lower Switches (S_2, S_4, S_6)
1	$S_1 = T_1 + T_2 + T_0 / 2$ $S_3 = T_2 + T_0 / 2$ $S_5 = T_0 / 2$	$S_4 = T_0 / 2$ $S_6 = T_1 + T_0 / 2$ $S_2 = T_1 + T_2 + T_0 / 2$
2	$S_1 = T_1 + T_0 / 2$ $S_3 = T_1 + T_2 + T_0 / 2$ $S_5 = T_0 / 2$	$S_4 = T_2 + T_0 / 2$ $S_6 = T_0 / 2$ $S_2 = T_1 + T_2 + T_0 / 2$
3	$S_1 = T_0 / 2$ $S_3 = T_1 + T_2 + T_0 / 2$ $S_5 = T_2 + T_0 / 2$	$S_4 = T_1 + T_2 + T_0 / 2$ $S_6 = T_0 / 2$ $S_2 = T_1 + T_0 / 2$
4	$S_1 = T_0 / 2$ $S_3 = T_1 + T_0 / 2$ $S_5 = T_1 + T_2 + T_0 / 2$	$S_4 = T_1 + T_2 + T_0 / 2$ $S_6 = T_2 + T_0 / 2$ $S_2 = T_0 / 2$
5	$S_1 = T_2 + T_0 / 2$ $S_3 = T_0 / 2$ $S_5 = T_1 + T_2 + T_0 / 2$	$S_4 = T_1 + T_0 / 2$ $S_6 = T_1 + T_2 + T_0 / 2$ $S_2 = T_0 / 2$
6	$S_1 = T_1 + T_2 + T_0 / 2$ $S_3 = T_0 / 2$ $S_5 = T_1 + T_0 / 2$	$S_4 = T_0 / 2$ $S_6 = T_1 + T_2 + T_0 / 2$ $S_2 = T_2 + T_0 / 2$

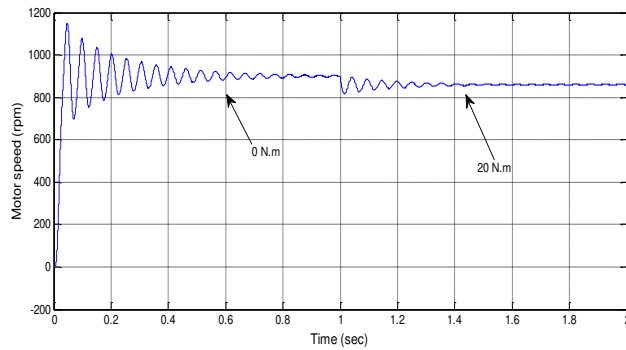

Figure 24. Rotor Speed Due to Step Change in Load Torque

Table 3. Comparison of Various Performance Details for Three Types

Dc bus voltage =804.08 v - modulation index for three types =0.70 - full load torque = 20 [N.m]						
Modulation technique	Fundamental phase voltage(v)	Fundamental line voltage(v)	RMS phase voltage (v)	RMS line voltage(v)	Speed (rpm)	THD %
SVM	375.92	651.08	265.80	460.40	1766	108.0
THPWM	325.45	563.61	230.12	398.55	1753	143.2
SPWM	282.43	489.11	199.75	345.93	1737	174.6

This academic article was published by The International Institute for Science, Technology and Education (IISTE). The IISTE is a pioneer in the Open Access Publishing service based in the U.S. and Europe. The aim of the institute is Accelerating Global Knowledge Sharing.

More information about the publisher can be found in the IISTE's homepage:

<http://www.iiste.org>

CALL FOR JOURNAL PAPERS

The IISTE is currently hosting more than 30 peer-reviewed academic journals and collaborating with academic institutions around the world. There's no deadline for submission. **Prospective authors of IISTE journals can find the submission instruction on the following page:** <http://www.iiste.org/journals/> The IISTE editorial team promises to review and publish all the qualified submissions in a **fast** manner. All the journals articles are available online to the readers all over the world without financial, legal, or technical barriers other than those inseparable from gaining access to the internet itself. Printed version of the journals is also available upon request of readers and authors.

MORE RESOURCES

Book publication information: <http://www.iiste.org/book/>

Recent conferences: <http://www.iiste.org/conference/>

IISTE Knowledge Sharing Partners

EBSCO, Index Copernicus, Ulrich's Periodicals Directory, JournalTOCS, PKP Open Archives Harvester, Bielefeld Academic Search Engine, Elektronische Zeitschriftenbibliothek EZB, Open J-Gate, OCLC WorldCat, Universe Digital Library, NewJour, Google Scholar

