

Lawrence Berkeley National Laboratory

Lawrence Berkeley National Laboratory

Title

Validation of the CERTS Microgrid Concept The CEC/CERTS Microgrid Testbed

Permalink

<https://escholarship.org/uc/item/1k60c4rw>

Authors

Nichols, David K.
Stevens, John
Lasseter, Robert H.
et al.

Publication Date

2006-06-01

Validation of the CERTS Microgrid Concept

The CEC/CERTS Microgrid Testbed

David K. Nichols, Member, IEEE, John Stevens, Member, IEEE, Robert H. Lasseter, Fellow, IEEE,

Joseph H. Eto, Member, IEEE, Harry T. Vollkommer, Member, IEEE

Abstract—The development of test plans to validate the CERTS Microgrid concept is discussed, including the status of a testbed. Increased application of Distributed Energy Resources on the Distribution system has the potential to improve performance, lower operational costs and create value. Microgrids have the potential to deliver these high value benefits. This presentation will focus on operational characteristics of the CERTS microgrid, the partners in the project and the status of the CEC/CERTS microgrid testbed.

Index Terms—Distributed Generation, Distributed Resource, Islanding, Microgrid, Microturbine

I. INTRODUCTION

DISTRIBUTED ENERGY RESOURCES (DER) hold promise for solving many issues facing electric utilities. By locating energy sources near the load, transmission and distribution assets are relieved, constraints reduced, energy efficiency increased, and asset utilization, power quality and reliability improved. Despite this impressive list of benefits, DER penetration has not met expectations. Major drawbacks to increased DER utilization are high cost, the need for custom engineering, lack of plug and play integration methods and few successful business models. Many private and public organizations are aggressively addressing these drawbacks, including the Department of Energy and state organizations.

The reported work is coordinated by the Consortium for Electric Reliability Technology Solutions and funded by the California Energy Commission Public Interest Energy Research Program under contract 500-03-024.

D.K. Nichols is retired from American Electric Power, Columbus, OH 43215 USA and is currently with Rolls Royce Fuel Cell Systems (e-mail: david.nichols@rolls-royce.com).

John Stevens is with Sandia National Laboratories, Albuquerque, New Mexico, 87185 USA (e-mail: jwsteve@sandia.gov).

J.H. Eto is with Lawrence Berkeley National Laboratory, Berkeley, CA 04720 USA (email: jheto@lbl.gov).

R.H. Lasseter is with the University of Wisconsin – Madison, Madison, WI, 53706 USA (email: lasseter@engr.wisc.edu).

Harry T. Vollkommer P.E. is retired from American Electric Power, Columbus, OH 43215 USA and currently an Electric Power System Consultant principal of Vollkommer Consulting LLC (email: HVOLLKOM@columbus.rr.com).

This paper discusses the CERTS Microgrid concept, the development of distributed generation (DG) sources with embedded controls that have been designed specifically for the CERTS Microgrid, and the development of a testbed for

testing the control and operation concepts of the CERTS Microgrid. The CERTS Microgrid concept addresses many of the barriers to increased DER application.

The Consortium for Electric Reliability Technology Solutions (CERTS) is an organization with participants from universities, national laboratories and private industry. CERTS focuses on research pertaining to electric reliability technologies. The CERTS Microgrid concept was developed as a means to improve reliability and to enhance power system efficiency using DER technologies. A high-speed switch and appropriate sensing is used to isolate the microgrid from the power system during abnormal grid conditions. This strategy allows the DER units to meet critical load demand and to improve protected circuits' power quality and reliability. Energy efficiency is enhanced by elimination of Transmission and Distribution losses and the application of DER sources that have combined heat and power (CHP) capabilities and high electrical efficiency. A unique characteristic of this concept is that high speed communications are not needed to control the individual DER units. Their controls automatically adjust to the new operating conditions that result when the switch operates.

It is envisioned that this microgrid concept will be used in industrial parks, commercial and institutional campuses and situations requiring improved reliability and power quality. Characteristically the application involves multiple DER devices dispersed throughout a system having thermal loads. Additionally, the controls have the flexibility to allow modification to the DER mix without required changes to control settings – plug and play integration. During a disturbance, when the microgrid is operating independent of the utility as an intentional island, the CERTS Microgrid controls take over the function of providing power and voltage control.

Fig. 1 below illustrates the CERTS microgrid design with protected critical load circuits and unprotected traditional load circuits.

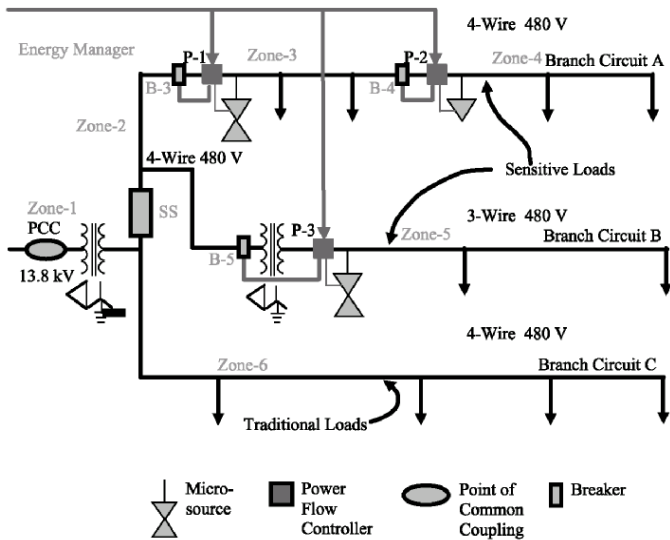

Fig. 1. The CERTS Microgrid testbed layout, showing branch circuits with sensitive loads and DG (hourglass-shaped items) and a circuit with non-sensitive (“traditional”) loads.

II. THE CONTROL STRATEGY IMPLEMENTATION

Briefly, the control strategy consists of employing two different droop controls in each DER that incorporate inverter technology with the appropriate embedded control algorithms. The two droop functions are voltage as a function of reactive power and power as a function of frequency. These controls are explained in depth in [1] and [2]. The voltage droop function and the frequency droop are always active.

The CERTS Microgrid takes a system approach by treating DER and associated loads as a single unit. The systems approach enables the CERTS Microgrid to lower the cost of DG installations, while at the same time increasing its value to both customers and the interconnected utility. A key feature of the microgrid is its ability, during a utility grid disturbance, to separate and isolate itself from the utility seamlessly with no disruption to the loads within the microgrid and no reduction in power quality. When the utility grid returns to normal, the microgrid resynchronizes and reconnects itself to the grid, in a seamless fashion. The CERTS Microgrid provides this technically challenging functionality without any expensive custom engineering. It also provides the required high system reliability and flexibility in the placement of generation within the microgrid.

During islanded operation of the microgrid all fault current is supplied by the inverter output of the sources. Thus, there is inadequate fault current for the use of normal protective devices such as fuses and circuit breakers. The DER controls detect faults when the microgrid is islanded and initiate proper operation.

III. THE CERTS MICROGRID TESTBED STATUS

The CEC/CERTS Microgrid testbed project team consists of American Electric Power, California Energy Commission (CEC), Lawrence Berkeley National Laboratory, Northern Power Systems, Sandia National Laboratories, Tecogen, University of Wisconsin, and Youtility, Inc.

The CERTS Microgrid concepts have been successfully bench-tested on the University of Wisconsin’s microgrid emulator. Three near-commercial Tecogen microsources were modified to implement the CERTS Microgrid control concepts, using inverters developed by Youtility. In parallel, a protection strategy was designed and tested by Northern Power Systems and University of Wisconsin. Starting in the fall of 2005, these elements were assembled at an American Electric Power facility and a full-scale test program of the CERTS Microgrid is underway.

The testbed was constructed at a site owned and operated by American Electric Power near Columbus, Ohio. This testbed, shown in Fig. 2 is a 480-volt system, connected to the distribution-voltage system through a transformer at the Point of Common Coupling (PCC on Fig. 1). The testbed has three 480-volt branch circuits, two containing “sensitive” loads and the third circuit with traditional non-sensitive loads. The static switch (SS) has the controls necessary to sense voltage disturbances and to open rapidly to protect the sensitive loads on circuits A and B.

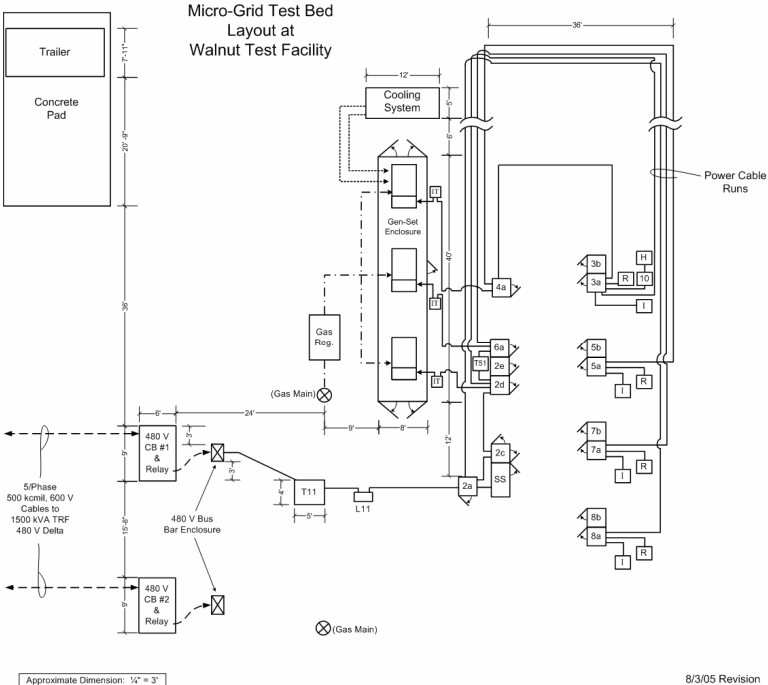

Fig. 2 The CERTS Microgrid testbed layout, 480 volt AC circuits, Gen-sets, 480 volt loads, trailers, enclosures and gas feeds at Walnut station

All instrumentation is housed in a test trailer located on a concrete pad within the test site. Measurement of system and device parameters is done with fiber optically isolated data acquisition systems and is logged by a site computer. All recorded data is available to team members through the project website. Fig. 2 also shows the dynamic loads that can be configured to meet test protocol requirement. The test program was developed by NPS working in collaboration with Team members.

IV. NEXT STEPS - DEMONSTRATION SITES

DOE has approved a second phase of this project. This next phase will study the integration of synchronous generators into the microgrid and methods to reduce protection and DC storage costs. The second phase project also will assess the functionality and cost benefits of electrical AC energy storage.

After testing at the testbed has been completed and thoroughly reviewed, several field demonstration sites will be sought where the CERTS Microgrid concept can be employed. These sites will be chosen based on appropriateness of the CERTS Microgrid for the particular installation, availability of thermal loads, and willingness of the site owner to work cooperatively with CERTS researchers.

References

- [1] Lasseter, R., A. Akhil, C. Marnay, J. Stephens, J. Dagle, R. Guttromson, A.S. Meliopoulos, R. Yinger, and J. Eto. "Integration of Distributed Energy Resources: The CERTS MicroGrid Concept" April 2002 Available:http://certs.lbl.gov/CERTS_P_DER.html
- [2] Lasseter, R., and P.Piagi. "Microgrid: A Conceptual Solution" PESC'04 Aachen, Germany 20-25 June 2004. Available: http://certs.lbl.gov/CERTS_P_DER.html

V. BIOGRAPHY

David K. Nichols (M'1994) holds a BSEE degree from Akron University. He began work at American Electric Power in 1972. He has held various managerial positions in AEP's Research and Corporate Technology Development Departments, including managing AEP's Dolan Technology Center in Groveport, Ohio. A specialist in high-voltage electrical and mechanical equipment and instrumentation, Nichols has overseen a wide range of research and development projects, including several distributed energy resource projects. He is currently employed by Rolls Royce Fuel Cell Systems, NA

Joseph H Eto (M'1987) holds AB and MS degrees from the University of California, Berkeley and has worked at the Lawrence Berkeley National Laboratory since 1982. Currently, he manages the program office for the Consortium for Electric Reliability Technology Solutions. He has authored over 150 publications on electricity reliability, utility resource planning, and demand-side management. In 2003, Joe was appointed to the Electric System Working Group of the U.S.-Canada Force on the August 14 Blackout.

Robert H. Lasseter (F'1992) received the Ph.D. in Physics from the University of Pennsylvania, Philadelphia in 1971. He was a Consulting Engineer at General Electric Co. until he joined the University of Wisconsin-Madison in 1980. His research interests focus on the application of power electronics to utility systems and technical issues which arise from the restructuring of the power utility system. This work includes interfacing micro-turbines and fuel cells to the distribution grid, microgrids, control of power systems through FACTS controllers, use of power electronics in

distribution systems and harmonic interactions in power electronic circuits. Professor Lasseter is a Fellow of IEEE, and chair of the PES subcommittee on Analysis and Modeling of DER

John Stevens (M'1981) is a graduate (BSEE and MSEE) of the University of New Mexico. John worked at Public Service Co of New Mexico and Plains Electric G&T Cooperative as a substation engineer, and for ARAMCO in Saudi Arabia before taking his current job with Sandia National Laboratories, where he has been since 1981. John's work at Sandia has dealt with utility interaction aspects of distributed resources, with an emphasis on photovoltaic systems. John was the chair of the working group that wrote IEEE STD 929-2000, on utility interconnection of photovoltaic systems

Harry Vollkommer (M) holds a BSEE from Indiana Institute of Technology and an MBA from Capital University. Harry retired in 2003 from American Electric Power Company with over 35 years experience, involving transmission, station and distribution system activities. He held various engineering and management positions, was project manager for multiple demonstration projects involving new technologies, and has participated in the development of IEEE standards, including 1547-2003 and 400.2-2004. He participated as a member of the IEEE Insulated Conductors Committee and Cable Engineering Committee in AEIC. He is a registered Professional Engineer in Ohio and Indiana