

both curves gives the wavelength of a longitudinal mode. As l_0 is much longer than l_1 in this laser, there exist many modes that can be excited in the neighborhood of an active cavity mode. In this figure, however, only mode A is excited, because it has the least threshold gain.⁹ Since the modes next to mode A have larger threshold gain and the mode with the second least threshold gain (denoted as mode B) exists with the spacing of about 18 Å, the longitudinal mode of the laser is transferred with this spacing.

Several improvements on the laser performance expected in this configuration are as follows: (1) narrowing of the spectral linewidth,^{7,8} (2) reduction of the oscillation frequency chirping,⁸⁻¹⁰ and (3) suppression of the intensity fluctuation (intensity noise).⁹ Concerning the spectral linewidth narrowing, good result has already been obtained for the IPC lasers, and the minimum spectral linewidth measured so far was about 900 kHz at full width at half maximum by the delayed self-heterodyne beat measurement.¹⁴ And for the chirping reduction, an oscillation frequency change of about 100 MHz/mA for 100-MHz sinusoidal current modulation has been obtained, which is considered to be the lowest value compared with the previously reported results that range from 0.11 to 1.5 GHz/mA.¹⁵⁻¹⁷ Detailed results and discussions about these improvements will be reported elsewhere.

In conclusion, we have proposed the IPC lasers, which have a novel, easily producible SAIL guide structure. The long IPC laser with a 3.55-mm-long passive cavity was operated in a single longitudinal mode and showed the effects of oscillation frequency stabilization, which are the essential factors for future optical sources.

The authors wish to thank T. Kajiwara, N. Hase, and their group members for their encouragement and fruitful discussions. They are also indebted to Y. Matsui and K. Fujito for their valuable advice.

- ¹S. Akiba, K. Utaka, K. Sakai, and Y. Matsushima, *Electron. Lett.* **18**, 77 (1982).
- ²K. Utaka, Y. Suematsu, K. Kobayashi, and H. Kawanish, *Jpn. J. Appl. Phys.* **19**, L137 (1980).
- ³W. T. Tsang, N. A. Olsson, and R. A. Logan, *Appl. Phys. Lett.* **42**, 650 (1983).
- ⁴Chinlon Lin, C. A. Burrus, R. A. Linke, I. P. Kaminow, J. S. Ko, A. G. Dentai, R. A. Logan, and B. I. Miller, *Electron. Lett.* **19**, 561 (1983).
- ⁵K.-Y. Liou, *Electron. Lett.* **19**, 750 (1983).
- ⁶S. Kitaji, T. Funahashi, and Y. Miura, *IEEE Global Telecommunications Conference, Atlanta, Conference Record 1984, Vol. 2*, pp. 619-623.
- ⁷M. W. Fleming and A. Mooradian, *IEEE J. Quantum Electron.* **QE-17**, 44 (1981).
- ⁸S. Saito, O. Nilsson, and Y. Yamamoto, *IEEE J. Quantum Electron.* **QE-18**, 961 (1982).
- ⁹T. Fujita, S. Ishizuka, K. Fujito, H. Serizawa, and H. Sato, *IEEE J. Quantum Electron.* **QE-20**, 492 (1984).
- ¹⁰T. Fujita, J. Ohya, S. Ishizuka, K. Fujito, and H. Sato, *Electron. Lett.* **20**, 416 (1984).
- ¹¹E. Garmire, G. Evans, and J. Niesen, *Appl. Phys. Lett.* **39**, 789 (1981).
- ¹²H. K. Choi and S. Wang, *Electron. Lett.* **19**, 302 (1983).
- ¹³A. Olsson and C. L. Tang, *IEEE J. Quantum Electron.* **QE-17**, 1320 (1981).
- ¹⁴T. Fujita, J. Ohya, K. Matsuda, M. Ishino, H. Sato, and H. Serizawa (unpublished).
- ¹⁵R. S. Tucker, J. E. Bowers, and C. A. Burrus, *Seventh Topical Meeting on Integrated and Guided-Wave Optics, Kissimmee, Florida, Tech. Dig. WB6-1*, 1984.
- ¹⁶G. P. Agrawal, N. A. Olsson, and N. K. Dutta, *Appl. Phys. Lett.* **45**, 119 (1984).
- ¹⁷N. K. Dutta, N. A. Olsson, L. A. Koszi, P. Besomi, R. B. Wilson, and R. J. Nelson, *J. Appl. Phys.* **56**, 2167 (1984).

Variable frequency picosecond optical pulse generation from laser diodes by electrical feedback

S. H. Izadpanah, J. Paslaski, Z. Rav-Noy, S. Margalit, and A. Yariv
California Institute of Technology, Pasadena, California 91125

(Received 7 January 1985; accepted for publication 5 March 1985)

High repetition rate picosecond optical pulse generation is achieved by providing electrical feedback (with and without external gain) to a self-pulsating laser diode. The feedback improves pulsation short-term stability (< 25-kHz frequency jitter) and narrows the laser pulses (14 ps).

Different techniques have been demonstrated to generate very short optical pulses from laser diodes. These include mode-locked laser,^{1,2} regenerative feedback,³ optoelectronic feedback,⁴ and mutual phase-locked loop.⁵ In this letter, we demonstrate that *passive* and active electrical feedback is an effective way of generating picosecond optical pulses using a high-frequency laser diode specially treated to self-pulsate.⁵

The electrical equivalent circuit of a self-pulsating laser diode includes a negative resistance that leads to a micro-

wave oscillation of electrical current through the diode,⁶ which thus acts as a microwave oscillator. An electrical feedback to such a diode plays electrically a role similar to that played optically by an external optical cavity. The diode/circuit interaction significantly improves the optical pulse train regularity and reduces the pulse width. This is particularly noticeable in lasers made on semi-insulating substrate, where the small parasitic reactances lead to large microwave bandwidth.

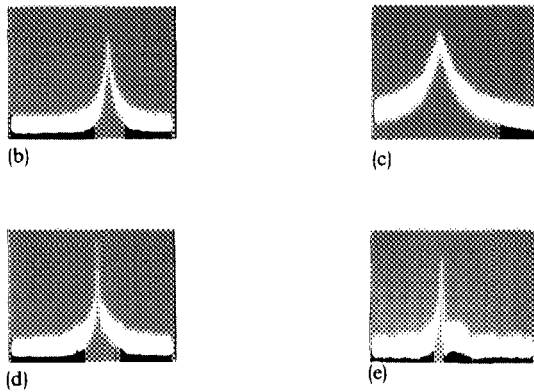
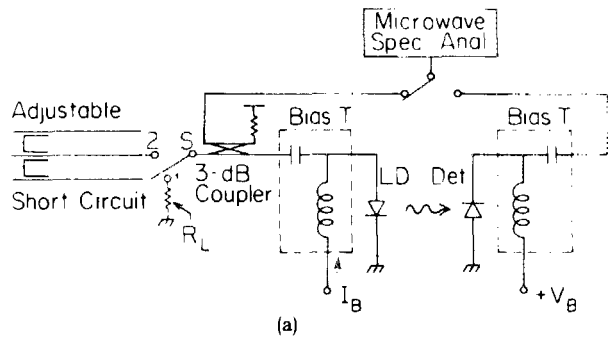

FIG. 1. (a) Passive feedback circuit arrangement; (b) microwave spectrum of laser pulsation, light spectrum free-running and (d) locked condition ($I/I_{th} = 1.2$, central frequency 1.5 GHz). (c) Current spectrum, free-running and (e) locked condition ($I/I_{th} = 1.4$ central frequency, 2.2 GHz). Vertical scale, 5 dB/div, horizontal scale, 50 MHz/div.

Figure 1(a) shows the circuit arrangement used to provide electrical feedback to a pulsating laser. The microwave spectrum of the laser's electrical signal or its detected light can be displayed on the spectrum analyzer. For switch S in position 1, the free-running laser spectra of detected light are shown in Fig. 1(b). The laser pulsation frequency at $I/I_{th} \approx 1.2$ is 1.55 GHz, with a typical spectral width of 20

MHz. For switch S in position 2 and a proper selection of delay line length, the spectra change to that of Fig. 1(d). The intensity output from the laser now pulsates with much reduced linewidth as a result of self phase locking. This stabilizes the optical pulsation rate and, as we will show, narrows the emitted optical pulse width, increases the pulse amplitude, and leads to an enhancement of its harmonic content.

The same effect of linewidth narrowing is observed for the electrical microwave signal. Figure 1(c) shows the current microwave spectrum of the free-running, self-pulsating laser at $I/I_{th} = 1.4$, with a self-pulsating frequency of 2.15 GHz. Figure 1(e) shows the electrical signal when the delay time is adjusted for an optimum linewidth.

Next, an *active* feedback loop with gain and phase control is inserted into the diode electrical circuit. The gain and return signal phases are independently controlled by the variable phase shifter and attenuator. Again, depending on the amplitude and phase of the feedback signal, phase locking takes place in a frequency range corresponding to a nearby resonant frequency of the external loop and a multiple of the diode free-running pulsation rate.

Figure 2(a) shows the circuit arrangement used to provide the active feedback. Shown in the same figure are the rf spectra of the detected light in the unlocked mode [Fig. 2(b)], just before locking [Fig. 2(c)], and after the onset of locking [Fig. 2(d)]. The width of the locked spectrum is ~ 23 kHz compared to 18 MHz in the free-running mode. This implies a frequency jitter of better than two parts in 10^5 .

Figures 3(a) and 3(b) show the fundamental and second harmonic components of the detected light and current in a free-running laser. After the application of active feedback, the spectra of both the current and detected light become narrow and the amplitude of the rf component increases. The frequency components of the detected light under the locked condition are shown in Fig. 3(c). It is seen that the harmonic contents are enhanced, and higher order harmonics are now easily detectable. This fact is further confirmed

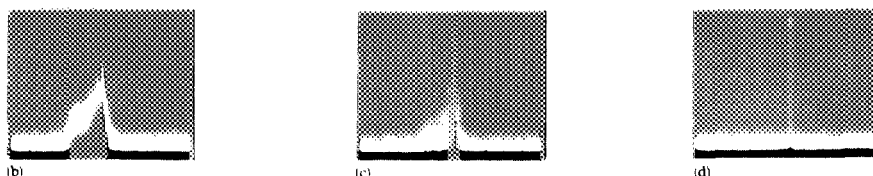
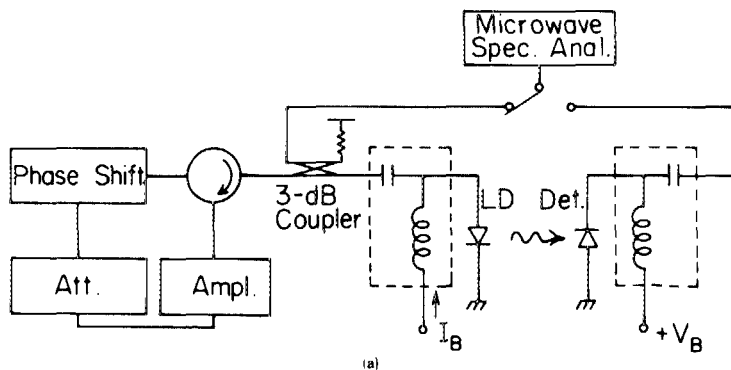

FIG. 2. (a) Active feedback circuit arrangement; (b) microwave spectrum of phase-locking steps to (d) ($I/I_{th} = 1.4$, central frequency 2.65 GHz). Vertical scale, 5 dB/div, horizontal scale, 200 kHz/div.

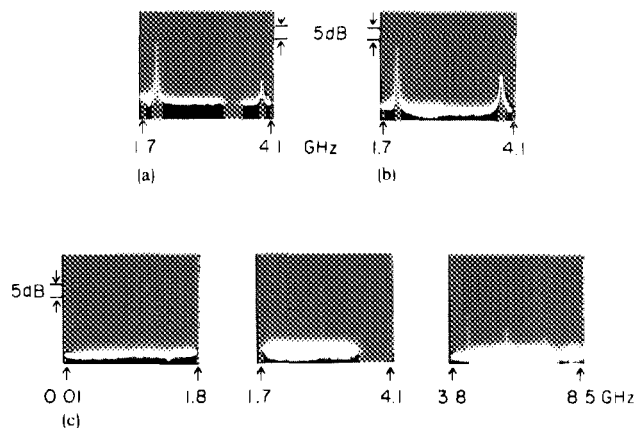

FIG. 3. (a) and (b) Harmonics of free-running and (c) locked laser pulsation under active feedback condition.

by the change in the laser output pulse width. As the free-running, self-pulsation frequency varies with pump current, variable frequency pulsation can be obtained by tuning the diode current and feedback parameters.

The optical pulse width was measured by the intensity autocorrelation technique using second-harmonic generation (SHG) in LiIO_3 . Figure 4 shows the intensity autocorrelation traces of the laser output for (a) free-running and (b) passive feedback conditions and (c) with active feedback of 20-dB gain. Assuming a Gaussian pulse, the full width at half-maximum of trace (c) is ~ 14 ps compared to a 57-ps pulse width for the free-running case.

In conclusion, we have demonstrated a new method of generating picosecond optical pulses by applying electrical feedback to a pulsating laser diode. A typical 15–20-dB gain in the feedback circuit improves the pulsating regularity to one in 10^5 and reduces the pulse width below 15 ps. The technique is highly suitable for an integrated laser/microwave oscillator, with the possibility of variable frequency pulse train generation.

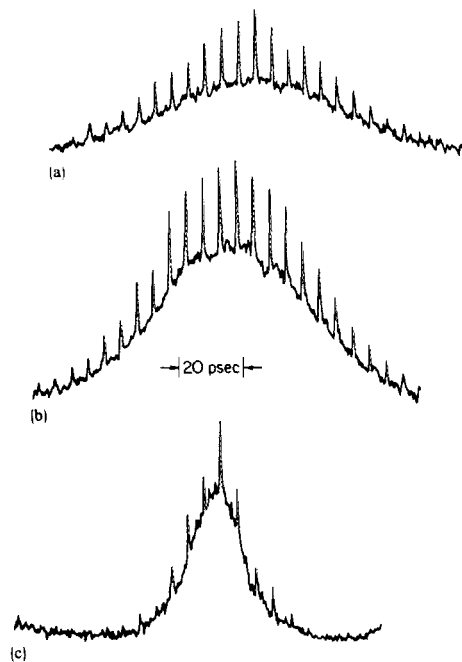

FIG. 4. (a) Autocorrelation traces of laser self-pulsation under free-running, (b) passive feedback, and (c) active feedback conditions.

This research was supported by the Office of Naval Research, the Air Force Office of Scientific Research and from a research grant from the ITT Corporation. The lasers used in this project were donated by the ORTEL Corporation.

¹E. P. Ippen and D. J. Eilenberger, *Appl. Phys. Lett.* **37**, 267 (1980).

²J. P. Van der Ziel, R. A. Logan, and R. M. Mikulyak, *Appl. Phys. Lett.* **39**, 867 (1981).

³T. L. Paoli and J. E. Ripper, *Appl. Phys. Lett.* **16**, 96 (1970).

⁴K. Y. Lau and A. Yariv, *Appl. Phys. Lett.* **45**, 124 (1984).

⁵S. H. Izadpanah, Z. Rav-Noy, S. Mukai, S. Margalit, and A. Yariv, *Appl. Phys. Lett.* **45**, 609 (1984).

⁶J. Katz, S. Margalit, C. Harder, D. Wilt and A. Yariv, *IEEE J. Quantum Electron.* **QE-17**, 4 (1981).