

ROBERT HARDT

DENNIS SULLIVAN

**Variation of the Green function of Riemann surfaces and
Whitney's holomorphic stratification conjecture**

Publications mathématiques de l'I.H.É.S., tome 68 (1988), p. 115-138

http://www.numdam.org/item?id=PMIHES_1988__68__115_0

© Publications mathématiques de l'I.H.É.S., 1988, tous droits réservés.

L'accès aux archives de la revue « Publications mathématiques de l'I.H.É.S. » (<http://www.ihes.fr/IHES/Publications/Publications.html>) implique l'accord avec les conditions générales d'utilisation (<http://www.numdam.org/conditions>). Toute utilisation commerciale ou impression systématique est constitutive d'une infraction pénale. Toute copie ou impression de ce fichier doit contenir la présente mention de copyright.

NUMDAM

Article numérisé dans le cadre du programme
Numérisation de documents anciens mathématiques

<http://www.numdam.org/>

VARIATION OF THE GREEN FUNCTION
ON RIEMANN SURFACES AND WHITNEY'S HOLOMORPHIC
STRATIFICATION CONJECTURE

by ROBERT HARDT* and DENNIS SULLIVAN*

*With great admiration to René Thom
who explained what « manifolds with singularities » are.*

Introduction

A complex algebraic variety can frequently be studied by the following two step procedure:

1. Prove an appropriate theorem for curves (i.e. Riemann surfaces).
2. Fiber an n -dimensional variety by curves, apply Step 1 to the fibers, and proceed by induction.

In our case the desired result about a Riemann surface concerns how the Green function varies when the conformal structure changes in a particular manner provided inductively in Step 2. We assume the Riemann surface \mathcal{M} is given as a k -sheeted branched covering of the unit disk \mathbf{B} with branch points a_1, \dots, a_l in $\mathbf{B}_{1/2}$. We also suppose that ψ is an ε -isometry of the unit disk in the sense that $|\log \text{dist}[\psi(x), \psi(y)] - \log \text{dist}(x, y)| < \varepsilon$ for $x, y \in \mathbf{B}$. Then there is a corresponding induced Riemann surface \mathcal{M}^ψ over \mathbf{B} with branch set $\psi(a_1), \dots, \psi(a_l)$ and a commutative diagram

$$\begin{array}{ccc} \mathcal{M} & \xrightarrow{\tilde{\psi}} & \mathcal{M}^\psi \\ \downarrow & & \downarrow \\ \mathbf{B} & \xrightarrow{\psi} & \mathbf{B} \end{array}$$

* Research partially supported by the National Science Foundation.

Theorem A (§ 4.5). — *There is a constant N_0 depending only on k and l so that, for $\varepsilon < 1/4(l - 1)$,*

$$|G_{\mathcal{M}, \omega}(x) - G_{\mathcal{M}^\psi, \tilde{\psi}(\omega)}(\tilde{\psi}(x))| \leq N_0 \text{ for } x \in \mathcal{M} \sim \{\omega\},$$

where the Green function $G_{\mathcal{M}, \omega}$ (respectively, $G_{\mathcal{M}^\psi, \tilde{\psi}(\omega)}$) is the unique positive harmonic function on \mathcal{M} (resp. \mathcal{M}^ψ) that has a unit mass pole at ω (resp. $\tilde{\psi}(\omega)$) and that vanishes on $\partial\mathcal{M}$ (resp. $\partial\mathcal{M}^\psi$).

This estimate for the variation of the Green function is far from true for ε -almost isometric *Poincaré* metrics on a Riemann surface. This will be clear from the proof in § 4.

We use Theorem A to treat Whitney’s conjecture (1956 [W, § 9]). For complex projective algebraic varieties, we show:

Theorem B (§ 6.1). — *Any complex algebraic subvariety of \mathbf{CP}^n admits a finite partition (stratification) \mathcal{S} into holomorphic submanifolds such that, for each stratum S in \mathcal{S} , every point of S has a neighborhood in \mathbf{CP}^n that may be foliated by $(\dim S)$ -dimensional holomorphic leaves that respect the strata.*

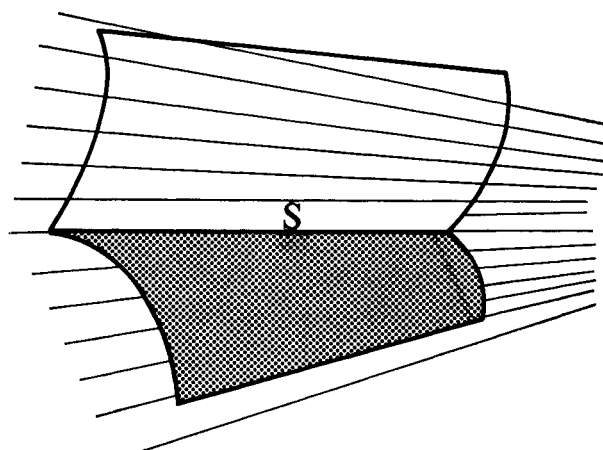

Whitney’s conjecture concerned real or complex analytic varieties. The real analytic case of the Whitney conjecture was treated in [H3, § 8], and the local complex analytic case is easy to obtain from the present paper. Here we treat the complex projective case because it is easy to describe the stratification globally in \mathbf{CP}^n (see 5.4). However, this stratification is not canonical, and it is not clear what class of stratifications admit such analytic foliations. In our inductive construction, the holonomy of these foliations locally preserve a fixed complete affine flag in \mathbf{C}^n , i.e.

parallel lines \subset parallel planes $\subset \dots$

Moreover, in each quotient \mathbf{C}^k , the induced maps are Lipschitz on each of the corresponding complex lines. In fact, in coordinates compatible with this flag, these homeo-

morphisms have Jacobian matrices a. e. which are upper triangular with diagonal entries bounded away from zero and infinity. Because the off diagonal partial derivatives are not uniformly bounded, the homeomorphisms are not fully Lipschitz (see [SS, p. 511], [M], and [P]) which was one of our original goals.

W. Thurston suggested some of the ideas used in proving Theorem A, in particular, the plumbing metric of § 3. In this metric, $\mathbf{S}^2 \sim \{4 \text{ points}\}$ may look like

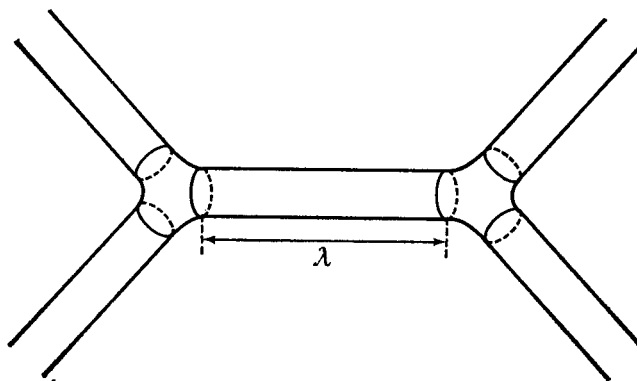

In our ε -variation, the length λ changes to $\lambda \pm \varepsilon$; whereas, in the corresponding Poincaré metric ε -variation, λ would change to $\lambda^{1 \pm \varepsilon}$.

In our proof of Theorem B, we employ an interpolation formula of H. Whitney [W, § 11] and generalize [W, § 12] where he proved that his conjecture held near a codimension 1 stratum in a hypersurface.

The plumbing metric is determined by the locations of the branch points in the unit disk. By scaling, we first obtain a unique decomposition of the disk that respects the clustering of subsets of the branch set (see the figure in § 1). In § 2, we observe that this clustering and hence the decomposition are essentially preserved under an ε -isometry of the disk. An explicit formula for the plumbing metric, in terms of the decomposition, is given in § 3 and is used in § 4 for a uniformly accurate approximate formula for the Green function. This formula is based on a corresponding problem on a one-dimensional network, and, along with a linear algebra lemma (4.4), provides a proof of Theorem A. The stratification for Theorem B is obtained inductively using a sequence of corank 1 projections (as in [H1], [H2], [H3]). Trying to construct the trivializing maps by induction leads one to the interpolation problem studied by H. Whitney in [W, § 11]. Use of the interpolation formula of [W, § 11] requires (as explained in 2.2 and the proof of 6.1) that the movement of points on the variety between corresponding one-dimensional fibers be an ε -isometry, for some positive ε (depending only on the variety). Attempting to prove this needed uniform estimate by an argument analogous to [W, § 12] led to investigating the Green function property of Theorem A. For the special case of behavior near a codimension 1 stratum in a hypersurface (as

treated in [W, § 12]), the appropriate Riemann surface is a simple branched cover of a once-punctured disk and the Green function may be suitably approximated by simply using a logarithm function.

1. The Swiss cheese decomposition of a multiply-punctured disk

1.1. Notation. — For a finite nonempty subset E of \mathbf{C} , let c_E denote the center of mass of E ($c_E = \sum_{e \in E} e$) and ρ_E denote the smallest ρ such that the closed ball $\mathbf{B}_\rho(c_E)$ contains E .

For a family \mathcal{E} of at least two finite nonempty disjoint subsets of \mathbf{C} , let

$$\sigma_{\mathcal{E}} = \max \{ r : \mathbf{B}_{4r}(c_E) \cap \mathbf{B}_{4r}(c_F) = \emptyset \text{ for distinct } E, F \in \mathcal{E} \}.$$

1.2. Lemma. — For a finite nonempty $A \subset \mathbf{C}$, the family \mathcal{P}_A of all partitions \mathcal{E} of A for which $\max_{E \in \mathcal{E}} \rho_E \leq (1/4) \sigma_{\mathcal{E}}$ contains a unique partition \mathcal{E}^A with $\sigma_{\mathcal{E}^A} = \max_{\mathcal{E} \in \mathcal{P}_A} \sigma_{\mathcal{E}}$.

Proof. — Since $\{\{z\} : z \in A\} \in \mathcal{P}_A$, and \mathcal{P}_A is finite, there exists a maximizing partition \mathcal{E}^A . Moreover \mathcal{E}^A is unique because $|z - w| \geq (15/2) \sigma_{\mathcal{E}^A}$ whenever z and w belong to distinct members of \mathcal{E}^A . \square

1.3. Lemma. — For $\ell \in \{2, 3, \dots\}$,

$$\mu_\ell = \sup \{ 2\rho_A / \sigma_{\mathcal{E}^A} : 2 \leq \text{card } A \leq \ell \} \text{ is finite.}$$

Proof. — We need only consider sets A with $c_A = 0$ and $\rho_A = 1$. We now argue by contradiction. If μ_ℓ were infinite, then there would exist $n \in \{1, 2, \dots, \ell\}$ and points $a_j^i \in \mathbf{B}_1(0)$ with $|a_j^i| = 1$ for $i \in \{1, 2, \dots, n\}$ and $j \in \{1, 2, \dots\}$ so that $a^i = \lim_{j \rightarrow \infty} a_j^i$ exists for each i , $0 = \lim_{j \rightarrow \infty} \sigma_{\mathcal{E}^A j}$, and $c_{A_j} = 0$ where $A_j = \{a_j^1, \dots, a_j^n\}$. Then $\text{card} \{a^1, \dots, a^n\} \geq 2$ because $|a^1| = 1$ and $\sum_{i=1}^n a^i = 0$. Let

$$s = (1/9) \inf \{ |a^h - a^i| : a^h \neq a^i \} \quad \text{and} \quad E_j^i = \mathbf{B}_s(a^i) \cap A_j.$$

Then $\mathcal{E}_j = \{E_j^i : i = 1, \dots, n\}$ is a partition of A_j and

$$\sigma_{\mathcal{E}^A j} \geq \sigma_{\mathcal{E}_j} \geq s > 0$$

for j sufficiently large, a contradiction. \square

1.4. Definitions. — A *Swiss cheese* (with I holes and modulus μ) is a set in the form $\mathbf{B}_r(c) \sim \bigcup_{i=1}^I \mathbf{B}_{r/\mu}(c_i)$ where $c_i \in \mathbf{B}_{r/2}(c)$ and

$$\min \{ |c_i - c_j| : 1 \leq i < j \leq I \} \geq 4r/\mu.$$

A *ring* is a Swiss Cheese with $I = 1$ and $c_1 = c$.

A *center-punctured disk* is a ring of modulus ∞ .

1.5. *The Swiss cheese decomposition.* — Given a finite subset A of \mathbf{C} with $\text{card } A \geq 2$ and a number $r \geq 4\rho_A$, we now use Lemmas 1.2 and 1.3 to obtain a unique finite partition $\mathcal{R}_A \cup \mathcal{S}_A \cup \mathcal{D}_A$ of $\mathbf{B}_r(c_A) \sim A$ where

- \mathcal{R}_A consists of rings with disjoint closures,
- \mathcal{S}_A consists of multi-holed Swiss cheeses with moduli $\leq \mu_l$, and
- \mathcal{D}_A consists of center-punctured disks.

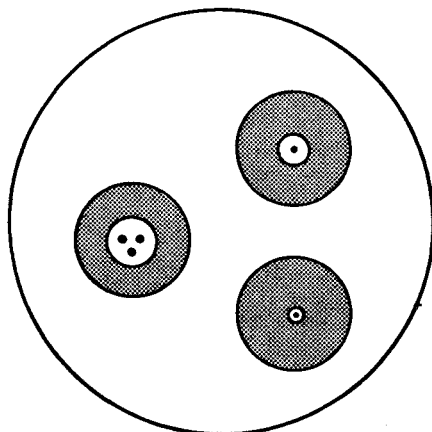

If $\text{card } A = 1$, then $A = \{c_A\}$, and we let $\mathcal{R}_A = \emptyset = \mathcal{S}_A$ and $\mathcal{D}_A = \{D_A\}$ where $D_A = \mathbf{B}_r(c_A) \sim \{c_A\}$.

If $\text{card } A \geq 2$, then we obtain the ring

$$R_A = \mathbf{B}_r(c_A) \sim \mathbf{B}_{2\rho_A}(c_A)$$

and, by 1.2 and 1.3, the multi-holed Swiss cheese

$$S_A = \mathbf{B}_{2\rho_A}(c) \sim \bigcup_{E \in \mathcal{E}^A} \mathbf{B}_{\sigma_{\mathcal{E}^A}}(c_A),$$

which has modulus $\leq \mu_l$.

For each $E \in \mathcal{E}^A$ we may repeat this construction with A , r replaced by E , $\sigma_{\mathcal{E}^A}$ to obtain either the center-punctured disk

$$D_E = \mathbf{B}_{\sigma_{\mathcal{E}^A}}(c_E) \quad \text{in case } \text{card } E = 1$$

or the ring and multi-holed Swiss cheese

$$R_E = \mathbf{B}_{\sigma_{\mathcal{E}^A}}(c_E) \sim \mathbf{B}_{2\rho_E}(c_E) \quad \text{and} \quad S_E = \mathbf{B}_{2\rho_E}(c_E) \sim \bigcup_{F \in \mathcal{E}^E} \mathbf{B}_{\sigma_{\mathcal{E}^E}}(c_F)$$

in case $\text{card } E \geq 2$.

Continuing we find that this process eventually ends; in fact, we readily estimate that

$$\text{card } \mathcal{D}_A \leq \ell, \quad \text{card } \mathcal{R}_A \leq (\ell - 1)^2, \quad \text{and} \quad \text{card } \mathcal{S}_A \leq \ell - 1.$$

Although the moduli of the Swiss cheeses in \mathcal{S}_A are all bounded by μ_l , the moduli of the rings in \mathcal{R}_A are *not* bounded independent of A .

2. Bilipschitz variation

2.1. Some elementary estimates. — For a bilipschitz homeomorphism $\psi : \mathbf{C} \rightarrow \mathbf{C}$, let

$$(1) \quad [\psi] = \sup_{z \in \mathbf{C}} \|D\psi(z) - \text{id}\|.$$

Then, by integration,

$$|\psi(z) - \psi(w) - (z - w)| \leq [\psi] |z - w| \quad \text{whenever } z, w \in \mathbf{C}.$$

Moreover, if $[\psi] \leq 1$, then

$$\begin{aligned} \|D\psi\| &\leq 1 + [\psi], & \|D\psi^{-1}\| &\leq (1 - [\psi])^{-1}, \\ [\psi^{-1}] &\leq [\psi] \|D\psi^{-1}\| & &\leq [\psi] (1 - [\psi])^{-1}. \end{aligned}$$

Recalling the notation of § 1, we readily observe, by integration, that

$$(2) \quad |\psi(c_{\mathbf{E}}) - c_{\psi(\mathbf{E})}| \leq [\psi] \rho_{\mathbf{E}}.$$

Moreover,

$$(3) \quad |1 - \rho_{\psi(\mathbf{E})} \rho_{\mathbf{E}}^{-1}| \leq 2[\psi]$$

because if $\rho_{\mathbf{E}} = |e - c_{\mathbf{E}}|$ and $\rho_{\psi(\mathbf{E})} = |\psi(a) - c_{\psi(\mathbf{E})}|$, then, by (2),

$$\begin{aligned} 1 - 2[\psi] &\leq [|\psi(e) - \psi(c_{\mathbf{E}})| / |e - c_{\mathbf{E}}|] - [\psi] \leq \rho_{\mathbf{E}}^{-1} |\psi(a) - \psi(c_{\mathbf{E}})| - [\psi] \\ &\leq \rho_{\psi(\mathbf{E})} \rho_{\mathbf{E}}^{-1} \leq \rho_{\mathbf{E}}^{-1} |\psi(a) - \psi(c_{\mathbf{E}})| + [\psi] \\ &\leq [|\psi(a) - \psi(c_{\mathbf{E}})| / |a - c_{\mathbf{E}}|] + [\psi] \leq 1 + 2[\psi]. \end{aligned}$$

Similarly,

$$(4) \quad |1 - |\psi(z) - c_{\psi(\mathbf{E})}||z - c_{\mathbf{E}}|^{-1}| \leq [\psi] \quad \text{whenever } |z - c_{\mathbf{E}}| \geq \rho_{\mathbf{E}}.$$

For any finite nonempty $A \subset \mathbf{C}$, it follows, as in the proof of 1.2, that

$$\begin{aligned} \mathcal{E}^{\psi(A)} &= \{\psi(\mathbf{E}) : \mathbf{E} \in \mathcal{E}\} \quad \text{and} \\ (5) \quad |1 - \sigma_{\mathcal{E}^{\psi(A)}} \sigma_{\mathcal{E}}^{-1}| &\leq 2[\psi] \quad \text{whenever } [\psi] \leq 1/4. \end{aligned}$$

In case

$$(6) \quad \psi[\mathbf{B}_r(c_A)] = \mathbf{B}_s(c_{\psi(A)}) \quad \text{for some } s > 4\rho_{\psi(A)} \text{ and } [\psi] \leq 1/4,$$

the Swiss cheese decompositions of $\mathbf{B}_r(c_A) \sim A$ and $\mathbf{B}_s(c_{\psi(A)}) \sim \psi(A)$ thus correspond; the sets $D_{\mathbf{E}}, R_{\mathbf{E}}, S_{\mathbf{E}}$ defined in 1.5 correspond to $D_{\psi(\mathbf{E})}, R_{\psi(\mathbf{E})}, S_{\psi(\mathbf{E})}$ and the ratios of corresponding radii are governed by (3) and (5).

2.2. A modified Whitney interpolation formula. — Given a bilipschitz map $\psi : \mathbf{C} \rightarrow \mathbf{C}$ as in 2.1, recall that the estimate

$$|\psi(z) - \psi(w) - (z - w)| / |z - w| \leq [\psi]$$

holds for any distinct $z, w \in \mathbf{C}$. Whitney observed in [W, § 10] that, conversely, given any $\ell \in \{2, 3, \dots\}$ and points $b = (b_1, \dots, b_\ell)$ and $d = (d_1, \dots, d_\ell)$ in \mathbf{C}^ℓ with the b_i 's distinct and

$$\Delta(b, d) = \max_{1 \leq i < j \leq \ell} |d_i - d_j - (b_i - b_j)| / |b_i - b_j| < 1/4(\ell - 1),$$

there *exists* a bilipschitz $\psi : \mathbf{C} \rightarrow \mathbf{C}$ with $\psi(b_i) = d_i$ for $i = 1, \dots, m$. Here, for use in 5.4, we describe and slightly modify his formula for ψ to give a map which is the identity near infinity.

For *distinct* b_1, \dots, b_ℓ in \mathbf{C} and $i \in \{1, 2, \dots\}$, the function σ_b^i defined by

$$\begin{aligned}\sigma_b^i(b_i) &= 1, \\ \sigma_b^i(b_j) &= 0 \quad \text{for } j \in \{1, \dots, \ell\} \sim \{i\}, \\ \sigma_b^i(z) &= |z - b_i|^{-1} / \sum_{j=1}^{\ell} |z - b_j|^{-1} \quad \text{for } z \in \mathbf{C} \sim \{b_1, \dots, b_\ell\},\end{aligned}$$

is continuous, as is the cut-off function α defined by

$$\begin{aligned}\alpha(z) &= 1 && \text{for } z \in \mathbf{B}_{r/2}(c), \\ \alpha(z) &= 2 - 2r^{-1} |z - c| && \text{for } z \in \mathbf{B}_r(c) \sim \mathbf{B}_{r/2}(c), \\ \alpha(z) &= 0 && \text{for } z \in \mathbf{C} \sim \mathbf{B}_r(c),\end{aligned}$$

where $c \in \mathbf{C}$ and $r > 0$ are fixed. Our interpolation is based on the function

$$\begin{aligned}\psi_{b,a} : \mathbf{C} &\rightarrow \mathbf{C}, \\ \psi_{b,a}(z) &= z + \alpha(z) \cdot \sum_{i=1}^{\ell} \sigma_b^i(z) (d_i - b_i).\end{aligned}$$

This satisfies $\psi_{b,a}(b_i) = d_i$ for $i = 1, \dots, \ell$, and

$$|\psi_{b,a}(z) - \psi_{b,a}(w) - (z - w)| \leq 8(\ell - 1) \Delta(b, d) |z - w|$$

whenever b_1, \dots, b_ℓ are distinct points in $\mathbf{B}_{r/2}(c)$ and d_1, \dots, d_ℓ, z , and w belong to \mathbf{C} .

To verify this, we repeat Whitney's calculation [W, p. 235] with his notation, while replacing σ_i by $\alpha\sigma_b^i$. For the first line of [W, p. 236] we have now the additional term $+\sigma_b^i \cdot (\partial\alpha/\partial\lambda)$, and so the factor 2 on the second line may be replaced by 3 because

$$|\rho_i \sigma_b^i(\partial\alpha/\partial\lambda)| \leq r \cdot r^{-1} = 1.$$

The remaining calculations of [W, p. 236] give the desired estimate. An immediate consequence is that *if*

$$0 < \Gamma < 1/8(\ell - 1), \quad b_1, \dots, b_\ell, \quad d_1, \dots, d_\ell \in \mathbf{B}_{r/2}(c),$$

and $(b, d) \in \text{Clos } \Delta^{-1}(0, \Gamma]$,

then, for any sequence $(b^{(h)}, d^{(h)})$ *in* $\Delta^{-1}(0, \Gamma]$ *approaching* (b, d) ,

$$\psi_{b,a} = \lim_{h \rightarrow \infty} \psi_{b^{(h)}, d^{(h)}}$$

defines a bilipschitz homeomorphism of \mathbf{C} *which is independent of the choice of the sequence* $(b^{(h)}, d^{(h)})$ *and which satisfies* $\psi_{b,a}(b_i) = d_i$ *and*

$$(1) \quad [\psi_{b,a}] \leq 8(\ell - 1) \Gamma.$$

Note that the points b_1, \dots, b_ℓ are *not necessarily distinct* even though, for each h , the points $b_1^{(h)}, \dots, b_\ell^{(h)}$ are distinct. Note also that, for fixed b and z , the function

$$(2) \quad \psi_{b,(\cdot)}(z) \text{ is holomorphic (in fact, affine) on } \{d : (b, d) \in \text{Clos } \Delta^{-1}(0, \Gamma)\}.$$

For completeness, we also discuss the case $\ell = 1$. Here for two points b, d in $\mathbf{B}_{r/2}(c)$, we define

$$\psi_{b,d}(z) = z + \alpha(z) (d - b)$$

and verify that

$$(3) \quad [\psi_{b,d}] \leq (2/r) |d - b|.$$

3. The plumbing metric for a branched cover of the disk

Here we explicitly construct a metric suggested by W. Thurston. Suppose A is a finite subset of \mathbf{C} , $\ell = \text{card } A \geq 2$, $4\rho_A < r < \infty$, \mathcal{M} is a connected compact bordered Riemann surface,

$$\Pi : \mathcal{M} \rightarrow \mathbf{B}_r(c_A)$$

is a k -sheeted branched cover with branch set contained in $\Pi^{-1}(A)$, and ω is a distinguished point of $\Pi^{-1}(A)$. Using § 1, we will now describe a complete metric (called the *plumbing metric*) on $\mathcal{M} \sim \{\omega\}$ whose curvature has bounds depending only on k and ℓ . In this metric \mathcal{M} will consist of several pipes of varying lengths, but all of circumference 1, which are assembled together by fittings of compact bordered surfaces having uniformly bounded geometry.

The desired metric is in the form θds^2 where θ is a positive smooth function on $\mathcal{M} \sim \{\omega\}$ and ds^2 denotes the Π -pullback of the Euclidean metric on \mathbf{C} . It suffices to describe θ on each component G of the Π inverse image of a member of the Swiss cheese decomposition (1.5) of $\mathbf{B}_r(c_A) \sim A$. Let $k_G \in \{1, \dots, k\}$ denote the multiplicity of the covering map $\Pi | G$.

To handle the transition between adjacent components we employ a *fixed* smooth monotone function $\eta : [-\infty, 1] \rightarrow [0, 1]$ with

$$\begin{aligned} \eta(t) &= 0 \quad \text{for } t \leq 0, & \eta(1) &= 1, \\ \eta^{(i)}(0) &= 0 = \eta^{(i)}(1) \quad \text{for } i = 1, 2, \dots, \end{aligned}$$

and define, for any numbers $0 < a < b < \infty$ and smooth functions $f, g : [0, \infty) \rightarrow \mathbf{R}$, the transition function

$$\begin{aligned} h &= h(a, b, f, g) : [0, b] \rightarrow \mathbf{R}, \\ h(t) &= [1 - \eta[(t - a)/(b - a)]]f(t) + \eta[(t - a)/(b - a)]g(t). \end{aligned}$$

Then h is smooth with

$$h | [0, a] = f | [0, a] \quad \text{and} \quad h^{(i)}(b) = g^{(i)}(b) \quad \text{for } i = 0, 1, 2, \dots$$

Let $\zeta_c(x) = |\Pi(x) - c|$ for $x \in \mathcal{M}$ and $c \in \mathbf{C}$.

Using this notation and that of § 1, we now explicitly define θ :

(1) For any component G of $\Pi^{-1}(\mathbf{U} \mathcal{D}_A)$ with $\omega \notin \text{Clos } G$, let

$$\theta \equiv (2\pi\alpha)^{-1} \quad \text{on } \text{Clos } G \quad \text{where } \alpha \text{ is the radius of } \Pi(G).$$

(2) For the component D of $\Pi^{-1}(\mathbf{U} \mathcal{D}_A)$ with $\omega \in \text{Clos } D$, let

$$\theta = h[\beta/2, \beta, [2\pi k_D(\cdot)]^{-1}, (2\pi\beta)^{-1}] \circ \zeta_{\Pi(\omega)} \quad \text{on } D$$

where β is the radius of $\Pi(D)$.

(3) For any Swiss cheese $S = \mathbf{B}_\gamma(d) \sim \mathbf{U}_{i=1}^I \mathbf{B}_\delta(d_i) \in \mathcal{S}_A$, note that $\mathbf{U}_{i=1}^I \mathbf{B}_\delta(d_i)$ is contained in $\mathbf{B}_{5\gamma/8}(d)$ by § 1, and let

$$\theta = h[5\gamma/8, \gamma, (2\pi\delta)^{-1}, (2\pi\gamma)^{-1}] \circ \zeta_d \quad \text{on } \Pi^{-1}(S).$$

(4) For any component Q of $\Pi^{-1}(\mathbf{U} \mathcal{R}_A)$, let

$$\theta = h[\rho, 4\rho/3, (2\pi\sigma)^{-1}, (2\pi k_Q \rho\sigma)^{-1} [\rho + \sigma + (\cdot)]] \circ \zeta_c$$

on $Q \cap \Pi^{-1}[\mathbf{B}_{4\rho/3}(c) \sim \mathbf{B}_\rho(c)],$

$$\theta = h[3\sigma/4, \sigma, (2\pi k_Q \rho\sigma)^{-1} [\rho + \sigma + (\cdot)], (2\pi\rho)^{-1}] \circ \zeta_c$$

on $Q \cap \Pi^{-1}[\mathbf{B}_\sigma(c) \sim \mathbf{B}_{4\rho/3}(c)]$

where $\Pi(Q) = \mathbf{B}_\sigma(c) \sim \mathbf{B}_\rho(c)$.

For such sets C , D , and Q , observe that, in the plumbing metric θds^2 ,

C becomes a *flat disk* of circumference k_C ,

$D \cap \Pi^{-1} \mathbf{B}_{\alpha/2}(\Pi(\omega))$ becomes a *half-infinite right circular cylinder* of circumference 1, and

$Q \cap \Pi^{-1}[\mathbf{B}_{3\sigma/4}(c) \sim \mathbf{B}_{4\rho/3}(c)]$ becomes a *finite right circular cylinder* of circumference 1 and of length

$$(5) \quad \int_{4\rho/3}^{3\sigma/4} r^{-1} dr = \log(\sigma/\rho) + \log(9/16) \quad \text{where } \Pi(Q) = \mathbf{B}_\sigma(c) \sim \mathbf{B}_\rho(c).$$

Finally the possible components of $\Pi^{-1}(S)$ for $S \in \mathcal{S}_A$ as well as the transition collars,

$$D \sim \Pi^{-1} \mathbf{B}_{\rho/2}(\Pi(\omega)) \quad \text{from (2),}$$

and $\Pi^{-1}[\mathbf{B}_{4\rho/3}(c) \sim \mathbf{B}_\rho(c)]$ and $\Pi^{-1}[\mathbf{B}_\sigma(c) \sim \mathbf{B}_{3\sigma/4}(c)]$ from (4),

form, in the plumbing metric, a *compact family of bordered Riemann surfaces*. For example, the boundaries occurring are circles of circumference at least μ_ℓ^{-1} and at most k . There exist universal bounds for the diameters and curvatures of all these surfaces in terms of k and ℓ .

4. An approximate formula for the Green function

Viewing, via the plumbing metric of § 2, $\mathcal{M} \sim \{ \omega \}$ as a system of unit circumference pipes joined with bounded-size junctures, we now imagine a unit flux water flow coming in from a source at infinity (ω) and exiting from $\partial \mathcal{M}$. The pressure at some point will be roughly the value of the Green function there. The approximate formula developed in 4.3 will show that this pressure is a Lipschitz function of the length of pipes with Lipschitz norm independent of these lengths. The proof involves considering

a corresponding model problem on a one-dimensional complex and establishing a linear algebra estimate (4.4) for equations derived from Kirchoff's laws.

Suppose ℓ , A , r , \mathcal{M} , Π , k , ω , D , β , θ are as in § 3, and let R_ω denote the (half) infinite right circular cylinder $D \cap \Pi^{-1} \mathbf{B}_{\beta/2}(\Pi(\omega))$.

4.1. Lemma. — *With respect to the plumbing metric, there exists a unique nonnegative harmonic function on $\mathcal{M} \sim \{\omega\}$ which vanishes on $\partial\mathcal{M}$ and has net inward flux one. (G is called the Green function with pole at ω .)*

Proof. — For $i = 2, 3, \dots$, choose a harmonic function h_i on

$$\mathcal{M}_i = \mathcal{M} \sim \{\omega\} \sim [R_\omega \cap \Pi^{-1} \mathbf{B}_{\beta/i}(\Pi(\omega))]$$

with $h_i|_{\partial\mathcal{M}} \equiv 0$ and $\text{grad } h_i|_{(\partial\mathcal{M}_i \sim \partial\mathcal{M})}$ equalling the outward unit normal vector field. Extending h_i to be 0 on $\mathcal{M} \sim \mathcal{M}_i$, we infer from the maximum principle and the Hopf boundary point lemma that all the h_i are bounded above by the harmonic function $h = -\log |\Pi \circ \psi - \Pi(\omega)|$ where $\psi: \mathcal{M} \sim \{\omega\} \rightarrow \mathcal{M} \sim \{\omega\}$ is a conformal mapping taking the plumbing metric to the Euclidean metric ds^2 . Moreover, near any of the poles $a \in \psi^{-1} \Pi^{-1}(\Pi(\omega))$ of h , the h_i are uniformly bounded by the maximum of h on a small circle about a . A subsequence of the h_i now converges uniformly on compact subsets of $\mathcal{M} \sim \{\omega\}$ to the desired function G .

For uniqueness, note that $|G \circ \psi^{-1} + \log |\Pi(\cdot) - \Pi(\omega)||$ is bounded near ω . Thus, for the difference of any two such G , the composition with ψ^{-1} would have a removable singularity at ω ; the maximum of the modulus of this difference would occur on $\partial\mathcal{M}$, where it is zero. \square

4.2. Lemma. — *With respect to the plumbing metric on $\mathcal{M} \sim \{\omega\}$,*

$$|\text{grad } G| \leq C_0$$

for some finite number C_0 depending only on k and ℓ (but not on A , r , \mathcal{M} , or ω).

Proof. — Note that the bound obtained in [S, Th. 1] is derived from bounds (e.g. Harnarck's inequality) based only on the curvature, which is here bounded uniformly. The flux one across the boundary, which is the level $G^{-1}\{0\}$, provides the desired uniform normalization. \square

4.3. A formula with uniformly bounded error.

Here [4.3 (1) (8) (9)] we show how G is *approximately linear on the cylinders described in § 2 and approximately constant on the other pieces*. The slopes of the linear functions are determined algebraically by just the cylinder lengths and the network configuration of these cylinders.

With R_ω being the (half) infinite cylinder as above, let R_1, R_2, \dots, R_m be the finite right circular cylinders; also let λ_i denote the length of R_i (see 3 (5)). Note that m is bounded in terms of k and ℓ .

As in § 3, the family \mathcal{V} of components of

$$\mathcal{M} \sim \{ \omega \} \sim \text{Int } R_\omega \sim \bigcup_{i=1}^m \text{Int } R_i$$

consists of surfaces belonging to a compact collection of compact bordered Riemann surfaces having uniform bounds on diameters and curvatures. For $V \in \mathcal{V}$, we let γ_V denote the mean value of G on V and infer from this uniformity and 4.2 that

$$(1) \quad |G - \gamma_V| \leq C_1 \quad \text{on } V$$

for some number C_1 depending only on k and ℓ .

Let V_ω be the unique member of \mathcal{V} which contains ∂R_ω . For $i \in \{1, \dots, m\}$, ∂R_i has two components. We choose one component and let V_i denote the member of \mathcal{V} that contains it. We then let W_i denote the member of \mathcal{V} containing the other component. Then the axial coordinate function

$$L_i(z) = \text{dist}(z, W_i)$$

is harmonic on $\text{Int } R_i$.

For $i \in \{1, 2, \dots, m\}$, $L_i|_{V_i \cap \partial R_i} \equiv \lambda_i$, and so, by 4.3 (1) and the maximum principle, we have the linear approximation

$$(2) \quad |G - [\gamma_{W_i} + \lambda_i^{-1}(\gamma_{V_i} - \gamma_{W_i}) L_i]| \leq C_1 \quad \text{on } R_i.$$

To see the behavior of G on R_0 , we first let $\gamma_0(t)$ denote the mean value of G on the circle $L_0^{-1}\{t\}$. By 4.2

$$|G - \gamma_0(t)| \leq C_0 \quad \text{on } L_0^{-1}\{t\};$$

hence, by the maximum principle,

$$|G - [\gamma_{W_0} + t^{-1}(\gamma_0(t) - \gamma_{W_0}) L_0]| \leq C_2 \quad \text{on } L_0^{-1}[0, t],$$

where $C_2 = \sup\{C_0, C_1\}$. From this and the net flux one condition, it follows that

$$t^{-1}[\gamma_0(t) - \gamma_{W_0}] \rightarrow 1 \quad \text{as } t \rightarrow \infty,$$

and so we also have the linear approximation

$$(3) \quad |G - (\gamma_{W_0} + L_0)| \leq C_2 \quad \text{on } R_0.$$

Note that we may view the piecewise approximations of (1) (2) (3) as being defined on the metric 1-complex (or graph) \mathcal{K} obtained by collapsing:

each $V \in \mathcal{V}$ to a vertex,

$\partial \mathcal{M}$ to a single vertex,

and each R_i to an edge ϵ_i .

To orient \mathcal{K} we may use the vector field $\text{grad } L_i$ on ε_i for $i = 0, 1, \dots, m$. We still need to estimate the numbers γ_V for $V \in \mathcal{V}$ in terms of the given lengths $\lambda_1, \dots, \lambda_n$ and the configuration type of \mathcal{K} . For this purpose we note, by Green's theorem, that the flux across the circle $L_i^{-1}\{t\}$,

$$(4) \quad \chi_i = \int_{L_i^{-1}\{t\}} \text{grad } G \cdot \text{grad } \ell_i,$$

is independent of $t \in [0, a_i]$. Green's theorem also implies the relations

$$(5) \quad \sum_{V_i = v} \chi_i - \sum_{W_i = v} \chi_i = 0 \quad \text{for any } V \in \mathcal{V} \\ \text{with } V \neq W_0 \quad \text{and } V \cap \partial \mathcal{M} = \emptyset,$$

$$(6) \quad \sum_{V_i = w_0} \chi_i - \sum_{W_i = w_0, i \neq 0} \chi_i = 1$$

because $\chi_0 = 1$. Integrating (4) over R_i gives

$$\lambda_i \chi_i = \gamma_i(a_i) - \gamma_i(a_0)$$

where $\gamma_i(t)$ is the mean value of G over the circle $L_i^{-1}\{t\}$; hence, by (1),

$$(7) \quad |\gamma_{V_i} - \gamma_{W_i} - \lambda_i \chi_i| \leq |\gamma_{V_i} - \gamma_i(a_i)| + |\gamma_i(0) - \gamma_{W_i}| \leq 2C_1.$$

We conclude from (2), (7) and (9) that, on each finite cylinder R_j ,

$$(8) \quad |G - \sum_{i=1}^m \alpha_i \chi_i \lambda_i - \chi_j L_j| \leq |G - \gamma_{W_j} - \lambda_j^{-1}(\gamma_{V_j} - \gamma_{W_j}) L_j| \\ + (L_j/\lambda_j) |\gamma_{V_j} - \gamma_{W_j} - \lambda_j \chi_j| \\ + |\sum_{i=1}^m \alpha_i (\gamma_{V_i} - \gamma_{W_i} - \chi_i \lambda_i)| \leq C_1 + 2C_1 + 2mC_1$$

where $\alpha = \sum_{i=1}^m \alpha_i \varepsilon_i$ is any simple path in \mathcal{K} from the $\partial \mathcal{M}$ vertex to the W_j vertex (here, $\alpha_i \in \{-1, 0, 1\}$). Similarly, on the infinite cylinder R_0 ,

$$(9) \quad |G - \sum_{i=1}^m \beta_i \chi_i \lambda_i - L_0| \leq |G - \gamma_{W_0} - L_0| \\ + |\sum_{i=1}^m \beta_i (\gamma_{V_i} - \gamma_{W_i} - \chi_i \lambda_i)| \leq C_2 + 2mC_1$$

by (3) and (7), where $\beta = \sum_{i=1}^m \beta_i \varepsilon_i$ is any simple path in \mathcal{K} from the $\partial \mathcal{M}$ vertex to the W_0 vertex. \square

Having obtained in (1), (8) and (9) above an approximate formula for G , we next prove a linear algebra lemma which gives a Lipschitz bound on the variation of this formula with changes in the lengths λ_i .

4.4. Circuit lemma. — Suppose \mathcal{K} is a connected oriented 1-complex (or graph) with oriented edges set $\{\varepsilon_1, \dots, \varepsilon_m\}$, vertex set \mathcal{V} , and two distinguished vertices v_ω and v_0 (the source and sink). For $i = 1, \dots, m$, let v_i and w_i denote the boundary vertices of the edge ε_i so that $\partial \varepsilon_i = v_i - w_i$. Also let

$$\ell_1 = \sum_{i=1}^m \ell_{1i} \varepsilon_i, \quad \ell_2 = \sum_{i=1}^m \ell_{2i} \varepsilon_i, \quad \dots, \quad \ell_n = \sum_{i=1}^m \ell_{ni} \varepsilon_i$$

be a basis for the simple loops of \mathcal{K} .

For $\lambda \in (0, \infty)^m$, $\mu \in \mathbf{R}^n$, and $\nu \in \mathbf{R}$, there exists a unique solution $x = x(\lambda, \mu, \nu) \in \mathbf{R}^n$ of the linear system

$$(0)_{\lambda, \mu, \nu} \quad \begin{cases} \sum_{i=1}^m \ell_{ji} \lambda_i x_i & = \mu_j \quad \text{for } j \in \{1, \dots, n\} & [\text{loop equations}], \\ \sum_{v_i=v} x_i - \sum_{w_i=v} x_i & = 0 \quad \text{for } v \in \mathcal{V} \sim \{v_0, v_\omega\} & [\text{vertex equations}], \\ \sum_{v_i=v_\omega} x_i - \sum_{w_i=v_\omega} x_i & = \nu & [\text{source equation}], \end{cases}$$

Moreover,

$$(1) \quad |\lambda_i x_i(\lambda, \mu, \nu)| \leq |\lambda_i| |\nu| + C_3 |\mu| \quad \text{and}$$

$$(2) \quad |\lambda_i x_i(\lambda, \mu, 1) - \bar{\lambda}_i x_i(\bar{\lambda}, \bar{\mu}, 1)| \leq C_3 (|\lambda - \bar{\lambda}| + |\mu| + |\bar{\mu}|),$$

for $i \in \{1, \dots, m\}$, $\lambda, \bar{\lambda} \in (0, \infty)^m$, $\mu, \bar{\mu} \in \mathbf{R}^n$, and $\nu \in \mathbf{R}$, where C_3 depends only on m .

Proof. — First note that $(0)_{\lambda, \mu, \nu}$ is a system of m equations (in the unknowns x_1, \dots, x_m) because there are, by Euler's theorem, exactly $m - n + 1$ distinct vertices in \mathcal{V} . Note also that the source equation, the vertex equations, and the identity

$$\sum_{v \in \mathcal{V}} [\sum_{v_i=v} x_i - \sum_{w_i=v} x_i] = \sum_{i=1}^m (x_i - x_i) = 0$$

imply the sink equation

$$\sum_{v_i=v_0} x_i - \sum_{w_i=v_0} x_i = -\nu.$$

To see that $(0)_{\lambda, \mu, \nu}$ has a unique solution whenever $\lambda \in (0, \infty)^m$, we observe that otherwise there would exist a nonzero solution $z = (z_1, \dots, z_m)$ of $(0)_{\lambda, 0, 0}$. Using the equation

$$\sum_{v_i=v} z_i - \sum_{w_i=v} z_i = 0$$

which would be true for all $v \in \mathcal{V}$, we would obtain a nonzero loop in the form $\sum_{i \in I} (\text{sgn } z_i) \varepsilon_i$. But then $\sum_{i \in I} (\text{sgn } z_i) \lambda_i z_i$ would be positive, contradicting that $\mu_j = 0$ for all j .

Next we will study $|x_i(\lambda, 0, \nu)|$. Since, as above, there are no nonzero loops of the form $\sum_{i \in I} [\text{sgn } x_i(\lambda, 0, \nu)] \varepsilon_i$, we may define a partial ordering on the vertex set \mathcal{V} by letting

$$\iota(v) = \sup \{ \text{card } I : x_i(\lambda, 0, \nu) \neq 0 \quad \text{for } i \in I, \\ \partial \sum_{i \in I} [\text{sgn } x_i(\lambda, 0, \nu)] \varepsilon_i = v_\omega - v \}$$

for $v \in \mathcal{V}$. Then we use $(0)_{\lambda, 0, \nu}$ to verify, for $\kappa = 1, 2, \dots$, that

$$\sum \{ [\text{sgn } x_i(\lambda, 0, \nu)] x_i(\lambda, 0, \nu) : \text{either } \iota(v_i) < \kappa \leq \iota(w_i) \quad \text{or } \iota(w_i) < \kappa \leq \iota(v_i) \}$$

is identically $|\nu|$. Thus

$$(3) \quad |x_i(\lambda, 0, \nu)| \leq |\nu|.$$

Next, to estimate $|\lambda_i x_i(\lambda, \mu, 0)|$, we note that the loop equations of $(0)_{\lambda, \mu, 0}$ imply, for any different loop-basis, equations whose right hand side gives a vector of length comparable to $|\mu|$. Since there are only finitely many such bases of simple loops, it suffices to prove an estimate

$$(4) \quad |\lambda_i x_i(\lambda, \mu, 0)| \leq C_4 |\mu|$$

with respect of any particular basis of loops. A basis, facilitating this estimate is obtained by starting with one loop ℓ_1 and a distinguished edge $\varepsilon_{i(1)}$ of ℓ_1 . Then, because $\ell_1 \sim \varepsilon_{i(1)}$ is simply-connected, we may choose a second loop ℓ_2 in $\mathcal{K} \sim \varepsilon_{i(1)}$ along with a distinguished edge $\varepsilon_{i(2)}$ of ℓ_2 . Continuing and discarding linearly dependent loops, we obtain a basis $\{\ell_1, \dots, \ell_n\}$ of loops with associated oriented edges $\varepsilon_{i(1)}, \dots, \varepsilon_{i(n)}$ so that $\pm \varepsilon_{i(j)}$ is an edge for ℓ_k if and only if $j = k$.

Assuming this loop condition holds, we fix $j \in \{1, \dots, n\}$ and now estimate $|\lambda_i x_i(\lambda, \mu e_j, 0)|$ where $\mu \in \mathbf{R}$ and e_j is the j -th unit coordinate vector in \mathbf{R}^n . Reorienting ℓ_j if necessary, we may assume $\mu \geq 0$. Let \mathcal{K}_j be the graph obtained from \mathcal{K} by adding a new vertex u to \mathcal{V} and by insisting that

$$\partial \varepsilon_{i(j)} = u - w_{i(j)} \quad (\text{rather than } v_{i(j)} - w_{i(j)}).$$

Thus, on \mathcal{K}_j , ℓ_j is no longer a closed loop, rather

$$\partial \ell_j = [\text{sgn } x_{i(j)}(\lambda, \mu e_j, 0)] (u - v_{i(j)}).$$

As above, the loop equations on \mathcal{K}_j now give a (potential) function $g : \mathcal{V} \cup \{u\} \rightarrow \mathbf{R}$ which is well-defined by:

$$\begin{aligned} g(v_{i(j)}) &= 0, & g(u) &= \mu, \\ g(v) &= \sum_{h \in \mathbf{H}} \lambda_i |x_h(\lambda, \mu e_j, 0)| \quad \text{whenever } \mathbf{H} \subset \{1, \dots, m\} \text{ and} \\ & \partial \sum_{h \in \mathbf{H}} [\text{sgn } x_h(\lambda, \mu e_j, 0)] \varepsilon_h = [\text{sgn } x_{i(j)}(\lambda, \mu e_j, 0)] (v - v_{i(j)}). \end{aligned}$$

For each $i \in \{1, \dots, m\}$, the edge $[\text{sgn } x_i(\lambda, \mu e_j, 0)] \varepsilon_i$ may, by the vertex equations, be extended to a path of the above form with boundary $u - w_i$. Since g is increasing along the vertices of this path,

$$|\lambda_i x_i(\lambda, \mu e_j, 0)| \leq \mu \quad \text{whenever } \lambda \in (0, \infty)^m \text{ and } \mu \in \mathbf{R}.$$

This implies (4) because $x_i(\lambda, \mu e_j, 0) = \sum_{j=1}^n x_i(\lambda, \mu e_j, 0)$. After changing loop bases as described above, we obtain (1) from (3), (4), and superposition.

To establish (2) we use (1) and superposition to reduce to the case $\mu = 0$. Since $\lambda_i x_i(\lambda, 0, 1)$ is homogeneous of degree 1 in λ , it suffices to prove that

$$(5) \quad \sup_{\lambda \in \mathbf{Q}} \frac{\partial}{\partial \lambda_k} [\lambda_i x_i(\lambda, 0, 1)] < \infty$$

where $\mathbf{Q} = \{\lambda \in (0, \infty)^m : |\lambda| = 1\}$ and $i, k \in \{1, 2, \dots, m\}$. Note that, for each such i, k , Cramer's rule implies that, on $(0, \infty)^m$,

$$(6) \quad x_i(\lambda, 0, 1) = [A_i^k(\lambda) \lambda_k + B_i^k(\lambda)] / [C_i^k(\lambda) \lambda_k + D_i^k(\lambda)]$$

where the $A_i^k, B_i^k, C_i^k, D_i^k$ are polynomials that do not depend on λ_k . Here the denominator $d_i^k(\lambda)$ is the determinant of the coefficient matrix of $(0)_{\lambda, 0, 1}$. We show that d_i^k is bounded away from zero on $\text{Clos } \mathbf{Q}$ by induction on m . The case $m = 1$ being trivial, we assume this is true for $m - 1$, but (for contradiction) not true for m . Since d_i^k is clearly nonzero and continuous on \mathbf{Q} , there would then be a sequence λ^p on \mathbf{Q}

approaching a point $\lambda^0 \in \text{Clos } Q \sim Q$ with $\lim_{p \rightarrow \infty} d_i^k(\lambda^p) = 0$. Then $\lambda_h^0 = 0$ for some $h \in \{1, \dots, m\}$. Let \mathcal{K}^h be the oriented graph obtained from \mathcal{K} by collapsing the edge ε_h to a single vertex $v_h = w_h$. Then a corresponding $m - 1$ by $m - 1$ linear system for \mathcal{K}^h is obtained from $(0)_{\lambda, 0, 1}$ by eliminating the one variable x_h and replacing the vertex equations for v_h and w_h by the sum of these two equations (with $v_h = w_h$). Then evaluating the determinant $d_i^k(\lambda^p)$ by expanding on the h -th column, we readily verify that $\pm d_i^k(\lambda^p)$ is precisely the determinant of the coefficient matrix for the new system associated with \mathcal{K}^h . By induction this determinant is nonzero. This contradiction establishes the positive lower bound of $|d_i^k|$ on Q .

Differentiating (6) and using this lower bound now gives (5). \square

4.5. Variation of the Green function. — Suppose ψ is as in § 2 and satisfies 2.1 (5) with the set A as above. Repeating the discussion of § 3 and 4.1 with A and Π replaced by $\psi(A)$ and $\psi \circ \Pi$, we obtain another plumbing metric and corresponding Green function G^ψ on $\mathcal{M} \sim [\omega]$ (which is harmonic with respect to the *new* conformal structure induced by $\psi \circ \Pi$).

Theorem. — One has $|G - G^\psi| \leq N_0$ whenever $[\psi] \leq 1/4$, for some finite number N_0 depending only on k and ℓ (but not on $A, r, \mathcal{M}, \omega$, or ψ).

Proof. — The corresponding Swiss cheese decompositions discussed in 2.1 (5) pullback via Π and $\psi \circ \Pi$ to corresponding partitions of $\mathcal{M} \sim \{\omega\}$. The corresponding oriented graphs \mathcal{K} and \mathcal{K}^ψ are homeomorphic.

We wish to use 4.3 (8) (9) to approximately describe G and G^ψ . For this, we may choose corresponding paths α and α^ψ and β and β^ψ with coefficients $\alpha_i = \alpha_i^\psi$ and $\beta_i = \beta_i^\psi$ in $\{-1, 0, 1\}$. From 2.1 (3) (4) and 3 (5) we readily compare the corresponding lengths

$$|\lambda_i - \lambda_i^\psi| \leq 8[\psi] \quad \text{whenever } [\psi] \leq 1/4.$$

Next, for any loop ℓ_j as in 4.4, we let

$$\mu_j = \sum_{i=1}^m \ell_{ji} \lambda_i \chi_i, \quad \mu_j^\psi = \sum_{i=1}^m \ell_{ji} \lambda_i^\psi \chi_i^\psi,$$

and infer from 4.3 (7) that

$$|\mu_j| \leq \left| \sum_{i=1}^m \ell_{ji} [\lambda_i \chi_i - g_{v_i} - g_{w_i}] \right| + \left| \sum_{i=1}^m \ell_{ji} [g_{v_i} - g_{w_i}] \right| \leq 2mC_1 + 0,$$

and similarly that $|\mu_j^\psi| \leq 2mC_1$. Letting

$$\begin{aligned} \lambda &= (\lambda_1, \dots, \lambda_n), & \lambda^\psi &= (\lambda_1^\psi, \dots, \lambda_n^\psi), & \mu &= (\mu_1, \dots, \mu_m), \\ \mu^\psi &= (\mu_1^\psi, \dots, \mu_m^\psi), \end{aligned}$$

we use 4.3 (5) (6) and the Circuit Lemma 4.4 to deduce that

$$(1) \quad \begin{aligned} (\chi_1, \dots, \chi_m) &= x(\lambda, \mu, 1), & (\chi_1^\psi, \dots, \chi_m^\psi) &= x(\lambda^\psi, \mu^\psi, 1), \quad \text{and} \\ | \lambda_i \chi_i - \lambda_i^\psi \chi_i^\psi | &\leq C_3[|\lambda - \lambda^\psi| + |\mu| + |\mu^\psi|] \leq C_3(8[\psi] + 4mC_1) n. \end{aligned}$$

Moreover, since each R_j , for $j = 1, \dots, n$, is a right circular cylinder with respect to either metric, the corresponding axial distance functions are proportional; in particular,

$$(2) \quad \sup_{\mathbb{R}_j} |\chi_i L_i - \chi_i^\psi L_i^\psi| = |\chi_i \lambda_i - \chi_i^\psi \lambda_i^\psi| \leq C_3(8[\psi] + 4mC_1) n.$$

Finally, a computation similar to that of § 3(5) shows that, on the infinite cylinder R_0 ,

$$(3) \quad |L_0 - L_0^\psi| \leq 6[\psi].$$

Noting that $\chi_0 = 1 = \chi_0^\psi$, we may now combine (1), (2), and (3) with our approximate formulas 4.3 (8) (9) to complete the proof. \square

5. Stratification via corank 1 projection

5.1. Definitions. — A holomorphic submanifold S of \mathbf{CP}^n which occurs as a connected component of the difference of two subvarieties of \mathbf{CP}^n is here called an (algebraic) *stratum*. In this case $\text{Clos } S$ is an irreducible subvariety and $\text{Fron } S = \text{Clos } S \sim S$ is a subvariety of lower dimension. A finite partition \mathcal{S} of a subvariety of \mathbf{CP}^n into strata is here called an (algebraic) *stratification* if

$$S \subset \text{Fron } \tilde{S} \text{ whenever } S \in \mathcal{S}, \tilde{S} \in \mathcal{S}, \text{ and } S \cap \text{Fron } \tilde{S} \neq \emptyset.$$

A stronger notion is that of a *localizable stratification* \mathcal{S} ; here

$$S \cap U \subset \text{Fron } G \text{ whenever } S \in \mathcal{S}, U \text{ is open, } G \text{ is a component of } \tilde{S} \cap U \text{ for some } \tilde{S} \in \mathcal{S}, S \cap U \text{ is connected, and } S \cap U \cap \text{Fron } G \neq \emptyset.$$

A stratification \mathcal{S} is *compatible with* a family \mathcal{Z} of sets if

$$S \subset Z \text{ whenever } S \in \mathcal{S}, Z \in \mathcal{Z}, \text{ and } S \cap Z \neq \emptyset.$$

Any k -dimensional subvariety Z of \mathbf{CP}^n contains a lower dimensional (singular) subvariety $\Sigma(Z)$ consisting of points near which Z fails to be a k -dimensional holomorphic submanifold. Moreover, for any holomorphic map $q : Z \rightarrow \mathbf{CP}^k$ having finite fibers, the set

$$\Sigma(Z, q) = \text{Clos} \{ z \in Z \sim \Sigma(Z) : \text{rank}[q|Z](z) < k \}$$

is also a subvariety of dimension less than k .

5.2. Lemma. — *For any finite family \mathcal{Z} of subvarieties of \mathbf{CP}^n and any holomorphic map q of a neighborhood of $X = \bigcup \mathcal{Z}$ into \mathbf{CP}^{n-1} , there exists a stratification \mathcal{R} of X compatible with \mathcal{Z} such that:*

- (1) $\{ q(R) : R \in \mathcal{R} \}$ is a stratification of $q(X)$, and $q|R$ is a proper holomorphic immersion for each $R \in \mathcal{R}$.
- (2) For any localizable stratification \mathcal{E} of $q(X)$ compatible with $\{ q(R) : R \in \mathcal{R} \}$, the family \mathcal{S} of components of $X \cap q^{-1}(T)$, for $T \in \mathcal{E}$, is a localizable stratification of X compatible with \mathcal{R} , and $q|S$ is a proper holomorphic immersion with $q(S) \in \mathcal{E}$ for each $S \in \mathcal{S}$.

Proof of (1). — We use induction on $k = \dim X$. In case $k = 0$, X is finite, and (1) is trivial. For $k > 0$, the set

$$W = X \cap q^{-1}[\Sigma[q(X)] \cup q[\Sigma(X) \cup \Sigma(X, q) \cup \bigcup \{Z \in \mathcal{Z} : \dim Z < k\}]]$$

is a subvariety of \mathbf{CP}^n with $\dim W < k$. Letting \mathcal{Q} be the family of components of $X \sim W$, we apply induction with \mathcal{Z} replaced by

$$\mathcal{Y} = \{W\} \cup \{W \cap Z : Z \in \mathcal{Z}\} \cup \{\text{Fron } Q : Q \in \mathcal{Q}\}$$

to obtain a suitable stratification of $W = \bigcup \mathcal{Y}$. Using the rank theorem, we readily verify, as in [H1], that $\mathcal{R} = \mathcal{P} \cup \mathcal{Q}$ satisfies (1).

Proof of (2). — Here we use the rank theorem and find that the main difficulty is showing that the partition \mathcal{S} of strata satisfies the local frontier property of 5.1. It comes down to proving that, for S, U, C , and \tilde{S} as in 5.1, the set $S \cap U \cap \text{Fron } C$ is open (as well as closed) relative to the connected set $S \cap U$.

To show this, we suppose $z \in S \cap U \cap \text{Fron } C$ and choose neighborhoods Ω of z in U and Λ of $q(z)$ in $q(\Omega)$ so that

$$\begin{aligned} q|_{S \cap \Omega} \text{ is injective,} & \quad \Omega \cap X \cap q^{-1}[q(S \cap \Omega)] = S \cap \Omega, \\ q(S) \cap \Lambda \text{ is connected,} & \quad X \cap (\text{Bdry } \Omega) \cap q^{-1}(\Lambda) = \emptyset, \end{aligned}$$

and $q(D) = q(S) \cap \Lambda$ where $D = S \cap \Omega \cap q^{-1}(\Lambda)$. For any component E of $C \cap \Omega \cap q^{-1}(\Lambda)$ with $z \in \text{Fron } E$, $q(E)$ is a component of $q(\tilde{S}) \cap \Lambda$ with $q(z) \in \text{Fron } q(E)$. Thus

$$q(D) = q(S) \cap \Lambda \subset \text{Fron } q(E)$$

by the localizability of \mathcal{E} . Since $q|_D$ is injective and since

$$q(D) \cap q[(\text{Clos } E) \sim D] = \emptyset,$$

we see that

$$\begin{aligned} q(D \cap \text{Clos } E) &= q(D) \cap q(\text{Clos } E) = q(D) \cap \text{Clos } q(E) = q(D), \\ D \cap \text{Clos } E &= D, \quad D \subset \text{Clos } E, \quad \text{and} \\ S \cap \Omega \cap q^{-1}(\Lambda) &= D \subset S \cap U \cap [(\text{Clos } E) \sim C] \subset S \cap U \cap \text{Fron } C. \end{aligned}$$

Thus $S \cap U \cap \text{Fron } C$ is open relative to $S \cap U$. \square

5.3. Notation for \mathbf{CP}^n . — For any k dimensional subspace P of \mathbf{CP}^n ,

$$P^\perp = \{z = (z^0; \dots; z^n) \in \mathbf{CP}^n : z \cdot w = \sum_{i=0}^n z^i \bar{w}^i = 0 \text{ for all } w \in P\}$$

is a well-defined $n - k - 1$ dimensional subspace of \mathbf{CP}^n .

For any point $c = (c^0; \dots; c^n) \in \mathbf{CP}^n$, the (corank 1) projection

$$q_c : \mathbf{CP}^n \sim \{c\} \rightarrow \{c\}^\perp$$

is well-defined by $q_c(z) = [z^0 - |c|^{-2}(z \cdot c) c^0; \dots; z^n - |c|^{-2}(z \cdot c) c^n]$.

5.4. *Theorem.* — For any finite family \mathcal{Z} of proper subvarieties of \mathbf{CP}^n , there exist subvarieties

$$\emptyset = X_{-1} \subset X_0 \subset X_1 \subset \dots \subset X_n = \mathbf{CP}^n$$

and orthogonal points $c_0, c_1, \dots, c_n \in \mathbf{CP}^n$ with associated subspaces

$$P_j = \{c_{j+1}\}^\perp \cap \dots \cap \{c_n\}^\perp$$

and projections

$$p_j = q_{c_{j+1}} \circ \dots \circ q_{c_n} : \mathbf{CP}^n \sim P_j^\perp \rightarrow P_j$$

for $j = 0, \dots, n-1$, such that

$$\mathcal{S} = \{ \text{components of } X_k \sim X_{k-1} : k = 0, \dots, n \}$$

is a stratification of \mathbf{CP}^n compatible with \mathcal{Z} and such that, for each $i \in \{0, \dots, n\}$ and $j \in \{i, i+1, \dots, n-1\}$, X_i is purely i -dimensional, $X_i \cap P_j^\perp = \emptyset$, $p_j|_{X_i} \sim X_{i-1}$ is a holomorphic immersion, and

$$\begin{aligned} \mathcal{S}_j &= \{ \text{components of } p_j(X_k) \sim p_j(X_{k-1}) : k = 0, \dots, j \} \\ &= \{ p_j(S) : S \in \mathcal{S}, \dim S \leq j \} \end{aligned}$$

is a stratification of $p_j(X_j)$.

Proof. — We choose,

first, a purely $n-1$ dimensional subvariety Y_n containing $\mathbf{U}\mathcal{Z}$,

second, a point $c_n \in \mathbf{CP}^n \sim Y_n$, and

third, a stratification \mathcal{R}_n of Y_n satisfying the conclusions of 5.2 (1)

with \mathcal{Z} , X , q replaced by $\mathcal{Z} \cup \{Y_n\}$, Y_n , q_{c_n} .

Having chosen $Y_n, Y_{n-1}, \dots, Y_{j+1}, c_n, \dots, c_{j+1}$, and $\mathcal{R}_n, \dots, \mathcal{R}_{j+1}$, by downward induction, we choose,

first, a purely $(i-1)$ -dimensional subvariety Y_i of P_i containing $\mathbf{U}\mathcal{Z}$, where

$$\mathcal{Z}_i = \{ q_{c_{i+1}}(\text{Clos } R) : R \in \mathcal{R}_{i+1}, \dim R \leq i-1 \},$$

second, a point $c_i \in P_i \sim Y_i$, and

third, a stratification \mathcal{R}_i of Y_i satisfying the conclusions of 5.2 (1)

with \mathcal{Z} , X , q replaced by $\mathcal{Z}_i \cup \{Y_i\}$, Y_i , q_{c_i} .

Having obtained c_n, \dots, c_{i+1} , and $Y_n, \dots, Y_1 = \{c_0\}$, we use upward induction starting with $\mathcal{S}_0 = \{\{c_0\}\}$ to define

$$\mathcal{S}_i = \{ \text{components of } Y_i \cap q_{c_i}^{-1}(S) : S \in \mathcal{S}_{i-1} \}$$

for $i = 1, 2, \dots, n$. Then, $X_i = \mathbf{U} \{ \text{Clos } S : S \in \mathcal{S}_n, \dim S \leq i \}$ is purely i -dimensional because $X_{n-1} = Y_n$, and, for $i = 0, \dots, n-2$,

$$X_i = Y_n \cap q_{c_n}^{-1}(Y_{n-1} \cap q_{c_{n-1}}^{-1}[\dots q_{c_{i+2}}^{-1}(Y_{i+1}) \dots]),$$

each Y_j is purely $(j - 1)$ -dimensional, and each fiber $q_i^{-1}\{y\} \cap Y_j$ is finite for $y \in Y_{i-1}$. Also

$$\mathcal{S}_n = \{ \text{components of } X_i \sim X_{i-1} : i = 0, \dots, n - 1 \},$$

and the conclusions of the theorem now follow by repeated use of 5.2 (2). \square

6. Local triviality and the Whitney conjecture

6.1. Theorem. — *With the subvarieties, projections, and the stratification \mathcal{S} obtained in Theorem 5.5, there exist, for any $j \in \{1, \dots, n - 1\}$ and point $a \in p_j(X_j) \sim p_j(X_{j-1})$, a relatively open ball U in P_j centered at a and a homeomorphism*

$$\Phi : U \times p_j^{-1}\{a\} \rightarrow p_j^{-1}(U)$$

so that, for each $u \in U$ and $v \in p_j^{-1}\{a\}$,

- (1) $p_j \circ \Phi(u, v) = u$,
- (2) $\Phi(U \times (S \cap p_j^{-1}\{a\})) \subset S$ for $S \in \mathcal{S}$,
- (3) $\Phi(U \times \{v\})$ is a holomorphic disk which p_j maps biholomorphically onto U , and
- (4) $\lim_{v \rightarrow w} \Phi(u, v) = w$ for $w \in P_j^\perp$.

Proof. — Since $p_{n-1} | X_{n-1} \sim X_{n-2}$ is a proper holomorphic covering map, the case $j = n - 1$ is easily treated. We assume that $j \leq n - 2$. Let

$$V = \text{Clos } p_j^{-1}\{a\} = p_j^{-1}\{a\} \cup P_j^\perp.$$

In a manner analogous with the proof of [H2, § 4], we will obtain Φ as Φ_n where, for $i = j + 1, j + 2, \dots, n$, balls U_i in P_j centered at a and maps Φ_i are obtained by increasing induction on i to satisfy the theorem with

$$\mathcal{S} \text{ and } V \text{ replaced by } \mathcal{S}_i \text{ and } V_i = V \cap P_i,$$

and to satisfy the commutativity

$$(5) \quad q_i \circ \Phi_i(u, \cdot) = \Phi_{i-1}(u, q_i(\cdot)) \quad \text{where } q_i = q_i | P_i \sim \{c_i\}.$$

To start the induction, note that $V_j = \{a\}$, let U_j be any ball in $P_j \sim p_j(X_{j-1})$ centered at a , and define $\Phi_j(u, a) = u$ for $u \in U_j$.

Assuming now that $i \geq j + 1$, we observe that the inductive definition of Φ_i from Φ_{i-1} reduces, by (5), to determining, for $u \in P_j$ near a and $y \in V_{i-1}$, a suitable map between the two complex lines

$$q_i^{-1}\{y\} \quad \text{and} \quad q_i^{-1}\{\Phi_{i-1}(u, y)\}$$

in P_i . Let Y_i be as in the proof of 5.4 so that

$$Y_i = p_i(X_{i-1}) = \bigcup \{ S \in \mathcal{S}_i : \dim S \leq i - 1 \}.$$

Since

$$(6) \quad q_i | Y_i \sim q_i^{-1}(Y_{i-1}) \quad \text{is a finite-sheeted holomorphic covering map,}$$

a bijection between the finite sets

$$Y_i \cap q_i^{-1}\{y\} \quad \text{and} \quad Y_i \cap q_i^{-1}\{\Phi_{i-1}(u, y)\} \quad \text{for } y \in V_{i-1} \sim Y_{i-1}$$

is uniquely determined by condition (2) (with \mathcal{S} replaced by \mathcal{S}_i) as follows:

- (7) For $x \in Y_i \cap q_i^{-1}\{y\}$, choose $S \in \mathcal{S}_i$ with $x \in S$ and any curve ζ from a to u in U_{i-1} . Then $\Phi_i(u, x)$ is the endpoint of the unique curve in S which begins at x and which is the lift under $q_i | S$ of the curve $\Phi_{i-1}(\zeta(\cdot), y)$.

To extend this bijection to the rest of the two complex lines $q_i^{-1}\{y\}$ and $q_i^{-1}\{\Phi_{i-1}(u, y)\}$, we will use the modified Whitney interpolation of 2.2. As discussed in 2.2, these interpolating maps give rise to interpolating maps also for points y in the “discriminant set” $Y_{i-1} \cap V_{i-1}$. Finally putting together all of these maps of lines, for all such u and y , we obtain the full map Φ_i .

The main difficulty here is verifying, for u sufficiently close to a , the necessary uniform (independent of y) estimate $[\Delta(b, d) < 1/8(\ell - 1)]$ on the relative positions of these finite subsets. In suitable local coordinates the quantity $\Delta(b, d)$ is here estimated by studying a multiple-valued holomorphic function $F_{u, w}$ obtained from the *difference* of two branches of Y_i which lie over the complex line

$$q_{i-1}^{-1}\{w\} \quad \text{for } w \in P_{i-1} \cap p_j^{-1}\{u\}.$$

To show that the *ratio* of $F_{u, w}$ and $F_{a, w}$, evaluated at corresponding points, approaches one uniformly (independent of w) as u approaches a , we study the *difference* of the expressions $\log |F_{u, w}|$ and $\log |F_{a, w}|$ evaluated on an appropriate branched cover of the disk. After subtracting off uniformly bounded harmonic functions, the latter functions become integral combinations of the Green functions studied in § 4. By the bound of 4.5, the difference of corresponding Green functions is uniformly bounded. Thus the ratios in question, viewed as functions of u alone, form a normal family of holomorphic functions, and the proof is easily completed.

We now argue in more detail. To use the affine constructions of § 2 and § 4, we need to describe two suitable maps, μ and ν , into \mathbf{C} which correspond roughly to the “ $(i - 1)$ -st and i -th coordinate functions”. By simply using a local holomorphic coordinate system near a , we could obtain a trivializing map defined locally near a . However to obtain a trivializing map that is defined globally in \mathbf{CP}^n with respect to the fiber variable, we use the more technical definitions of μ and ν given below.

First note that

$$W = \bigcup_{u \in U_{i-1}} \text{Clos } p_j^{-1}\{u\} = p_j^{-1}(U_{i-1}) \cup P_j^1,$$

and that there is, by induction, a retraction $\rho: W \cap P_{i-1} \rightarrow V_{i-1}$ such that

$$\rho[\Phi_{i-1}(u, v)] = v \quad \text{for } (u, v) \in U_{i-1} \times p_j^{-1}\{a\}.$$

Changing coordinates, we may assume that

$$c_0 = (1; 0; 0; \dots; 0), \dots, \quad c_n = (0; 0; \dots; 0; 1).$$

Choose continuous functions $\kappa_h : P_{i-1} \rightarrow [0, 1]$ for $h = 0, 1, \dots, i-1$ so that

$$\kappa_h \equiv 1 \text{ near } c_h \quad \text{and} \quad \kappa_h \equiv 0 \text{ near } c_k \text{ for } k \neq h.$$

Moreover, we may insist that

$$(8) \quad \kappa_{i-1} \equiv 0 \quad \text{and} \quad \kappa_h = \kappa_h \circ p_{i-1} \quad \text{for } h = 0, 1, \dots, i-2 \\ \text{on } \{y \in P_{i-1} : \text{dist}(y, c_{i-1}) > \frac{1}{4} \text{dist}(c_{i-1}, Y_{i-1})\}.$$

With the normalized weighting functions $\lambda_j = \kappa_j / \sum_{h=0}^{i-1} \kappa_h$, we now define

$$\mu(y) = y^{i-1} / \sum_{h=0}^{i-1} \lambda_h[\rho(y)] y^h \quad \text{for } y \in W \cap P_{i-1} \quad \text{and} \\ \nu(z) = z^i / \sum_{h=0}^{i-1} \lambda_h[\rho[q_i(z)]] z^h \quad \text{for } z \in W \cap P_i \sim \{c_i\},$$

and observe that each restriction

$$\mu | q_{i-1}^{-1}\{w\} \quad \text{for } w \in W \cap P_{i-2} \quad \text{and} \quad \nu | q_i^{-1}\{y\} \quad \text{for } y \in W \cap P_{i-1}$$

is a biholomorphic map onto \mathbf{C} ; let

$$\alpha_w : \mathbf{C} \rightarrow q_{i-1}^{-1}\{w\} \quad \text{and} \quad \beta_y : \mathbf{C} \rightarrow q_i^{-1}\{y\}$$

denote the corresponding inverse functions.

Let ℓ denote the multiplicity of the covering $q_i | Y_i \sim q_i^{-1}(Y_{i-1})$ so that, for each $y \in V_{i-1} \sim Y_{i-1}$, $\nu(Y_i \cap q_i^{-1}\{y\})$ is a set of ℓ distinct complex numbers, say

$$\nu(Y_i \cap q_i^{-1}\{y\}) = \{b_1(y), \dots, b_\ell(y)\}.$$

Using (6), let

$$d_j(u, y) = \nu[\Phi_i[u, \beta_y[b_j(y)]]] \quad \text{for } j = 1, \dots, \ell;$$

in particular, $d_j(a, y) = b_j(y)$. Letting $b = (b_1, \dots, b_\ell)$ and $d = (d_1, \dots, d_\ell)$, our main goal now is to prove, for $\ell \geq 2$, a uniform estimate (see 2.2)

$$(9) \quad \Delta[b(y), d(u, y)] \leq N_0 \text{dist}(u, a)$$

for all $y \in V_{i-1} \sim Y_{i-1}$ and $u \in P_j$ with $\text{dist}(u, a) \leq N_0^{-1}$. (The constants N_0, \dots, N_6 used below will only depend on the original varieties X_0, \dots, X_n .)

Since, by pure dimensionality, $Y_i = \text{Clos}[Y_i \sim q_i^{-1}(Y_{i-1})]$, Rouché's Theorem implies the continuity of the points with multiplicities of $Y_i \cap q_i^{-1}\{\cdot\}$ on all of V_{i-1} . From the estimate (9) [or 2.2 (3) in case $\ell = 1$], we may use 2.2 to obtain the interpolating bilipschitz homeomorphism

$$\Psi_{b(y), d(u, y)} : \mathbf{C} \rightarrow \mathbf{C}$$

for all $y \in V_{i-1}$. Then a suitable map Φ_i would be obtained by choosing U_i to be a small neighborhood of a in P_j and letting

$$(10) \quad \Phi_i[u, v] = \beta_{\Phi_{i-1}[u, v_{i-1}(v)]} \circ \Psi_{b[v_{i-1}(v)], d[u, v_{i-1}(v)]} \circ \nu[v]$$

for $(u, v) \in U_i \times V_i$.

To prove estimate (9), we now assume $\ell \geq 2$ and note, by (6), that (9) clearly holds uniformly for $\text{dist}(u, a) \leq N_1^{-1}$ and $y \in V_{i-1} \sim \Omega$ where

$$\Omega = \{y \in V_{i-1} : \text{dist}(y, c_{i-1}) > \frac{1}{2} \text{dist}(c_{i-1}, Y_{i-1})\}.$$

To prove (9) for points $y \in \Omega$, we will use the Green function estimate 4.5. First observe that

$$\varphi_{u,w} = \mu \circ \Phi_{i-1}(u, \cdot) \circ \alpha_w : \mathbf{C} \rightarrow \mathbf{C}$$

is a bilipschitz map satisfying an estimate

$$[\varphi_{u,w}] \leq N_2 \operatorname{dist}(u, a)$$

whenever $w \in V_{i-2}$, $u \in P_j$, and $\operatorname{dist}(u, a) \leq N_2^{-1}$. Consider the finite set

$$A_w = \mu\{Y_{i-1} \cap q_{i-1}^{-1}\{w\}\}$$

of complex numbers and choose $r > 4\rho_{A_w}$ so that

$$\alpha_w\{\partial \mathbf{B}_{r/2}(c_{A_w})\} \cap \Omega = \emptyset.$$

We wish to apply the discussion of § 4 to the finite set $\varphi_{u,w}(A_w)$. Unfortunately $\varphi_{u,w}(\mathbf{B}_r(c_{A_w}))$ may not be exactly a disk whose center is the center of mass of the set $\varphi_{u,w}(A_w)$. Nevertheless to obtain (9) for points $y \in \Omega$, we are free to modify $\varphi_{u,w}$ outside of $\mathbf{B}_{r/2}(c_{A_w})$. Accordingly we use (10) and 2.1 (2) (5) to choose a bilipschitz map $\psi_{u,w} : \mathbf{C} \rightarrow \mathbf{C}$ with

$$\begin{aligned} \psi_{u,w} | \mathbf{B}_{r/2}(c_{A_w}) &\equiv \varphi_{u,w} | \mathbf{B}_{r/2}(c_{A_w}), & [\psi_{u,w}] &\leq N_3 \operatorname{dist}(u, a), \quad \text{and} \\ \psi_{u,w}[\mathbf{B}_{r/2}(c_{A_w})] &= \mathbf{B}_{s_{u,w}}(c_{\psi_{u,w}(A_w)}) \quad \text{for some } s_{u,w} > 4\rho_{\psi_{u,w}(A_w)} \end{aligned}$$

whenever $w \in V_{i-1}$, $u \in P_j$, and $\operatorname{dist}(u, a) \leq N_3^{-1}$.

For any $w \in V_{i-2}$ and $z \in \mathbf{B}_r(c_{A_w}) \sim A_w$, we may choose $b[\alpha_w(z)]$ as above and any pair h, k of integers with $1 \leq h < k \leq \ell$, and then analytically continue the expression

$$b_h[\alpha_w(z)] - b_k[\alpha_w(z)]$$

over $\mathbf{B}_r(c_{A_w}) \sim A_w$ to give a bounded continuous multiple-valued function. This is holomorphic because the only non-analytic terms are the weight functions $\kappa_1, \dots, \kappa_{i-1}$ which are, by (8), constant on $\alpha_w[\mathbf{B}_r(c_{A_w})]$.

On an appropriate branched cover

$$\Pi_w : \mathcal{M}_w \rightarrow \mathbf{B}_r(c_{A_w})$$

$(b_h - b_k) \circ \alpha_w \circ \Pi_w$ becomes single-valued. We may construct Π_w so that it has at most ℓ^2 sheets and has branch set in $\Pi_w^{-1}(A_w)$. For estimate (9) we want to consider the corresponding difference function

$$F_{u,w} = [d_h(u, \cdot) - d_k(u, \cdot)] \circ \alpha_{\Phi_{i-2}(u,w)} \circ \Pi_w.$$

Establishing (9) now reduces to showing that, for any such choice of b, h , and k ,

$$(11) \quad |1 - F_{u,w}(x) F_{u,w}^{-1}(x)| \leq N_4 \operatorname{dist}(u, a)$$

whenever $w \in V_{i-2}$, $x \in \mathcal{M}_w$, $u \in P_j$, and $\operatorname{dist}(u, a) < N_0^{-1}$.

Let $\mathcal{M}_{u,w}$ denote the set \mathcal{M}_u equipped with the conformal structure that makes $\psi_{u,w} \circ \Pi_w$ holomorphic. Also we give $\mathcal{M}_{u,w}$ the plumbing metric of § 3 with Π replaced

by $\psi_{u,w} \circ \Pi_w$. Since the function $F_{u,w}$ is holomorphic on $\mathcal{M}_{u,w}$, Rouché's theorem implies that both the zero set

$$F_{u,w}^{-1}\{0\} \subset \Pi_w^{-1}(A_w)$$

and the order of vanishing n_ω of $F_{u,w}$ at any zero ω are independent of u near a . Thus we may write

$$(12) \quad -\log |F_{u,w}| = H_{u,w} + \sum_{\omega \in F_{u,w}^{-1}\{0\}} n_\omega G_{u,w,\omega}$$

where $H_{u,w}$ is harmonic on $\mathcal{M}_{u,w}$ and, for each $\omega \in F_{u,w}^{-1}\{0\}$, the function $G_{u,w,\omega}$ is a Green function on $\mathcal{M}_{u,w} \sim \{\omega\}$ as in § 4. Moreover,

$$(13) \quad N_5^{-1} \leq H_{u,w} \leq N_5 \text{ whenever } w \in V_{i-2}, u \in P_j, \text{ and } \text{dist}(u, a) \leq N_5^{-1},$$

by the maximum principle and the definition of $F_{u,w}$ because the set

$$\{ \text{dist}(z, \tilde{z}) : z, \tilde{z} \in X_i \cap q_i^{-1}\{y\}, z \neq \tilde{z}, y \in \alpha_w(\psi_{u,w}[\partial \mathbf{B}_r(c_{A_w})]), w \in V_{i-1}, u \in P_j, \text{dist}(u, a) \leq N_2^{-1} \}$$

is bounded above and below.

Combining (12) and (13) with the Green function estimate 4.5, we deduce the bound

$$|I_{w,x}(u)| \leq N_6 \text{ where } I_{w,x}(u) = F_{u,w}(x) \cdot F_{a,w}^{-1}(x)$$

for $w \in V_{i-2}$, $x \in \mathcal{M}_w$, $u \in P_j$, and $\text{dist}(u, a) < N_6^{-1}$. For each such w, x , the function $I_{w,x}$ is a holomorphic function on $\{u \in P_j : \text{dist}(u, a) < N_6^{-1}\}$ by (10), (6), and (the inductively-verified) holomorphic nature of $\Phi_{i-1}(\cdot, y)$ for $y \in V_{i-1}$. Moreover,

$$(14) \quad \lim_{u \rightarrow a} I_{w,x}(u) = 1.$$

The family

$$\{ I_{w,x} : w \in V_{i-2}, x \in \mathcal{M}_{u,w} \}$$

of holomorphic functions, being uniformly bounded by N_6 , becomes equi-Lipschitzian when restricted to compact subdomains. Thus the convergence in (14) is uniform, and we finally obtain (11) and hence (9). This, along with 2.2, shows that the expression (10) defines a homeomorphism satisfying (1) (with \mathcal{S} and V replaced by \mathcal{S}_i and V_i).

Noting that the weight functions $\kappa_0, \dots, \kappa_{i-1}$ are constant for fixed w and x , we see that expression (10) along with 2.2 (2) and induction also implies the holomorphic property (3). Finally property (4) follows from 2.2, and (2) is guaranteed by (7). \square

REFERENCES

GR] R. GUNNING and H. ROSSI, *Analytic functions of several complex variables*, Prentice-Hall, 1965.
 [H₁] R. HARDT, Topological properties of subanalytic sets, *Trans. Am. Math. Soc.*, **211** (1975), 57-70.
 [H₂] ———, Semi-algebraic local triviality in semi-algebraic mappings, *Amer. J. Math.*, **102** (1980), 291-302.
 [H₃] ———, Stratification via corank 1 projections, in *Singularities, Proc. Symp. in Pure Math.*, **40** (1983), 559-566.

- [M] T. MOSTOWSKI, Lipschitz equisingularity, *Dissertationes Math.*, CCXLIII (1985), 1-46.
- [P] A. PARUSIŃSKI, *Lipschitz stratification of real analytic sets*, Preprint, Gdańsk University, 1986.
- [SS] L. SIEBENMANN and D. SULLIVAN, On complexes that are Lipschitz manifolds, in *Geometric Topology*, New York, Academic Press, 1979, 503-552.
- [S] D. SULLIVAN, Growth of positive harmonic functions and Kleinian group limit sets of zero planar measure and Hausdorff dimension two, in *Geometry Symposium, Utrecht 1980, Lecture Notes in Math.*, 894, Berlin-New York, Springer, 1981, 127-144.
- [W] H. WHITNEY, Local properties of analytic varieties, in *Differential and Combinatorial Topology*, Princeton U. Press, 1965, 205-244.

School of Mathematics
University of Minnesota
Minneapolis, MN 55455 USA

Mathematics Department	&	Institut des Hautes Études Scientifiques
Graduate Center		35, route de Chartres
City University of New York		91440 Bures-sur-Yvette
33 West 42nd Street		France
New York, NY 10036 USA		

Manuscrit reçu le 12 septembre 1988.