

Vector processing as an enabler for software-defined radio in handheld devices

Citation for published version (APA):

Berkel, van, C. H., Heinle, F., Meuwissen, P. P. E., Moerman, C. M., & Weiss, M. (2005). Vector processing as an enabler for software-defined radio in handheld devices. *EURASIP Journal on Applied Signal Processing*, 2005(16), 2613-2625. <https://doi.org/10.1155/ASP.2005.2613>

DOI:

[10.1155/ASP.2005.2613](https://doi.org/10.1155/ASP.2005.2613)

Document status and date:

Published: 01/01/2005

Document Version:

Publisher's PDF, also known as Version of Record (includes final page, issue and volume numbers)

Please check the document version of this publication:

- A submitted manuscript is the version of the article upon submission and before peer-review. There can be important differences between the submitted version and the official published version of record. People interested in the research are advised to contact the author for the final version of the publication, or visit the DOI to the publisher's website.
- The final author version and the galley proof are versions of the publication after peer review.
- The final published version features the final layout of the paper including the volume, issue and page numbers.

[Link to publication](#)

General rights

Copyright and moral rights for the publications made accessible in the public portal are retained by the authors and/or other copyright owners and it is a condition of accessing publications that users recognise and abide by the legal requirements associated with these rights.

- Users may download and print one copy of any publication from the public portal for the purpose of private study or research.
- You may not further distribute the material or use it for any profit-making activity or commercial gain
- You may freely distribute the URL identifying the publication in the public portal.

If the publication is distributed under the terms of Article 25fa of the Dutch Copyright Act, indicated by the "Taverne" license above, please follow below link for the End User Agreement:

www.tue.nl/taverne

Take down policy

If you believe that this document breaches copyright please contact us at:

openaccess@tue.nl

providing details and we will investigate your claim.

Vector Processing as an Enabler for Software-Defined Radio in Handheld Devices

Kees van Berkel

Philips Research, Technical University Eindhoven, Professor Holstlaan 4, 5656 AA Eindhoven, The Netherlands
Email: kees.van.berkel@philips.com

Frank Heinle

Philips Semiconductors, BL Cellular Systems, 90443 Nuernberg, Germany
Email: frank.heinle@philips.com

Patrick P. E. Meuwissen

Philips Research, Technical University Eindhoven, Professor Holstlaan 4, 5656 AA Eindhoven, The Netherlands
Email: patrick.meuwissen@philips.com

Kees Moerman

Philips Semiconductors, DSP Innovation Center, Waalre, The Netherlands
Email: kees.moerman@philips.com

Matthias Weiss

Philips Semiconductors, BL Connectivity, 01099 Dresden, Germany
Email: matthias.weiss@philips.com

Received 15 February 2004; Revised 23 February 2005

A major challenge of software-defined radio (SDR) is to realize many giga operations per second of flexible baseband processing within a power budget of only a few hundred mW. A heterogeneous hardware architecture with the programmable vector processor EVP as key component can support WLAN, UMTS, and other standards. A detailed rationale for the EVP architecture, based on the analysis of a number of key algorithms, as well as implementation and benchmarking results are described.

Keywords and phrases: vector processing, software-defined radio, 3G baseband processing, wireless LAN, rake receiver.

1. INTRODUCTION

Future mobile handsets will need to support multiple wireless communication links, potentially including 2G cellular, 3G cellular, wireless local area network (WLAN), personal-area network (PAN), broadcast, and positioning. A layered structure of such a future network, adapted from [1], is shown in Figure 1 and Table 1.

These layers are to be integrated in a common, flexible, and seamless IP core network, supporting global roaming and a single access number per user. This requires both horizontal (intrasystem) and vertical (intersystem) handover, as indicated by the arrows. For each of these layers there exists a multitude of, often regional, standards. Some handheld devices may have to support multiple standards per layer, for example, in a world phone.

Individual standards typically evolve over the years towards higher bit rates, more features, and more services. For example, 3G cellular standards will need to support high-speed downlink packet access (HSDPA), and for WLAN multiple-antenna schemes are being studied (MIMO, IEEE 802.11 n).

For a given standard, new algorithms are continuously developed to improve performance (lower bit error rate, more efficient spectrum usage). Upgrading handsets by software would then be attractive, possibly by downloading of new software versions over the air interface.

In a typical scenario, multiple standards have to be supported in standby mode, plus one standard is active. In a high-end scenario, however, several links may be active simultaneously, for example, GSM (standby), DVB-T (data downlink), UMTS (uplink), Bluetooth, and GPS.

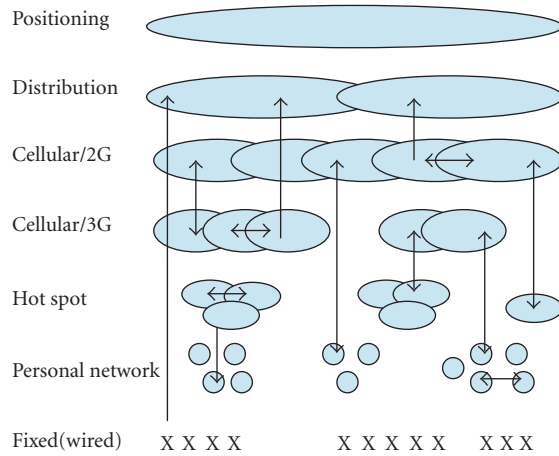

FIGURE 1: Layered structure of an integrated, seamless future network.

The combination of the above trends is sometimes referred to as 3G+ or 4G wireless. They form a powerful argument for so-called software-defined radio (SDR) [1].

In Section 2 we analyze the computational loads and flexibility requirements of the various stages of the baseband processing of an SDR. In Section 3, a number of baseband algorithms are analyzed in detail for execution on a vector processor. Detailed requirements for an SDR vector processor are collected in passing. Based on these requirements, two vector processors are presented in Section 4: the OnDSP, applied in WLAN products, and the EVP (embedded vector processor), being productized for 3G and beyond. Detailed load numbers for baseband kernels, including benchmarking are presented in Section 5. System results for WLAN and for UMTS are given in Section 6.

2. HW ARCHITECTURE FOR SDR BASEBAND

Estimates for the computational load (GHz) for baseband processing are given in Figure 2, with [2] as main source. Interestingly, the numbers roughly appear to apply to both nonoptimized programs on a Pentium 3 as well as to optimized (assembly) programs running on current DSPs used in GSM handsets.

The digital baseband processing for SDR can be split into three stages: a filter stage, a modem stage, and a codec stage, as shown in Figure 3.

The loads are more or less evenly distributed across the three baseband stages. Nevertheless, the stages have very different characteristics.

2.1. Filter stage

Various transmitter and receiver filters are required for band limitation, for example, root-raised cosine filters and sample-rate conversion. Given their high computational load (e.g., 2–5 billion multiplications and additions per second for UMTS), their regularity, and the commonality among the algorithms involved, full programmability would add

insufficient value to compensate for the additional power consumption. A configurable multistandard filter is more appropriate.

2.2. Modem stage

The modem stage, sometimes called “inner transceiver” or “signal conditioner,” appears to be the most diverse across the different standards. It includes functions such as rake reception, correlation, synchronization, joint detection, equalization, FFT, OFDM (de)mapping, interference cancellation, and so forth. Furthermore, new modulation schemes are proposed within the ongoing evolution of standards to improve throughput and performance. Also manufacturers are challenged to differentiate their products by improving algorithms to reduce BERs or transmit power for the same BER. This is the stage where dBs can be gained or lost by choosing and optimizing the right or wrong algorithms. This is the stage where programmability offers most value.

2.3. Codec stage

The codec stage, sometimes called “outer transceiver” involves a variety of functions: (de) multiplexing, (de) puncturing, (de) interleaving, and a variety of channel codecs (e.g., convolution, Turbo, Reed-Solomon). The performance of these functions is determined by standard algorithms, and allows little differentiation among manufacturers. Given the considerable similarities among standards and algorithms, and given the considerable processing requirements for higher bit rates (> 100 Mbps), a fully programmable solution does not appear to be justifiable. See also Sections 5.4 and 6.

2.4. Baseband hardware architecture

The above observations on the different baseband stages result in a proposal for a multistandard hardware architecture (Figure 4), comprising:

- (i) a general purpose microcontroller for link/MAC layer processing and for controlling baseband and RF tasks;
- (ii) a configurable filter processor;
- (iii) a programmable vector processor for number crunching, mostly in the modem stage;
- (iv) a conventional DSP for intrinsically “scalar” algorithms, for example, speech codecs;
- (v) one or more multistandard weakly configurable channel decoders, for example, Viterbi, Turbo.

3. VECTORIZATION OF BASEBAND KERNELS

Making vector parallelism explicit in program code is commonly called “vectorization.” Depending on the algorithm at hand, this can be relatively straightforward, or it may require some ingenuity. Unfortunately, the state-of-the-art of vectorizing compilation today cannot fully exploit the architectures discussed in Section 4 and at the same time achieve *efficient* code for SDR. Although we have been able to generate code

TABLE 1: Layers of a future seamless network.

Layer	Link range (log ₁₀ m)	Up/down	Mobility	Standards (examples)
Positioning	6-7	d	Full	GPS, Galileo
Distribution	5-6	d	Full	DAB, DVB-T/H
Cellular/2G	4-5	d,u	Full	GSM, IS95, PHS
Cellular/3G	3-4	d,u	Full	UMTS, CDMA2000, TD-SCDMA
Hot-spot	2-3	d,u	Local	802.11 a,b,g, wifi
Personal	1-2	d,u	Local	Bluetooth, DECT
Fixed	0-1	d,u	None	POTS

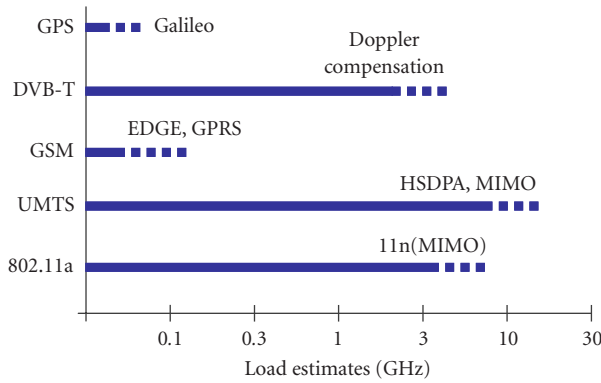

FIGURE 2: Load estimates for various SDR standards.

of acceptable efficiency for some algorithms, we rely on manual vectorization for the time being. Vectorization of several key algorithms is presented below. In the sequel we assume a vector processor that supports P (P a power of 2) identical operations to be executed in parallel (single-instruction multiple-data (SIMD)), as well as load (store) operations of P adjacent values from (into) a vector memory.

3.1. Golay correlator for UMTS-FDD

In a UMTS-FDD receiver, a Golay correlator is used for initial acquisition of a basestation signal. It is basically a filter (1) designed specifically to detect correlation peaks of the 256-chip long primary synchronization code (PSC [3]) transmitted during the first 10% of each timeslot on the primary synchronization subchannel (P-SCH) [4]:

$$y(k) = \sum_{n=0}^{255} \text{PSC}(255 - n) \times x(k - n) \quad (1)$$

with $\text{PSC}(i) \in \{-1, +1\}$ and x is one of the sample phases of the over-sampled input stream of complex (I,Q) numbers. The structure of $\text{PSC}(i)$ allows a factorization of the Golay correlator into five stages, as shown in (2). The alternative output stage $y'(k)$ is used only during initial frequency offset estimation.

Input x , output y , and intermediate signals y_s can be stored in cyclic buffers of appropriate sizes. With sharing of

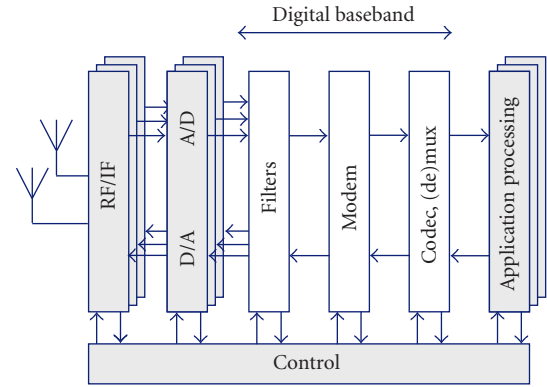

FIGURE 3: A crude SDR architecture with the baseband section split into filters, modem, and channel codec.

subexpressions, each output $y(k)$ requires 13 complex additions/subtractions, 14 memory reads, and 14 memory writes (of complex values). In principle, these operations can be executed in parallel. However, as all operands reside in different locations of the various buffers, the resulting parallel accesses to memory become highly irregular, incompatible with vector processing:

$$\begin{aligned} y_1(k) &= x(k-6) + x(k-4) + x(k-2) - x(k), \\ y_{2U}(k) &= y_1(k-1) + y_1(k), \\ y_{2L}(k) &= y_1(k-1) - y_1(k), \\ y_3(k) &= y_{2U}(k-8) + y_{2L}(k), \\ y_{4U}(k) &= y_3(k-48) + y_3(k-32) + y_3(k-16) - y_3(k), \\ y_{4L}(k) &= y_3(k-48) - y_3(k-32) + y_3(k-16) + y_3(k), \\ y(k) &= y_{4U}(k-192) - y_{4L}(k-128) \\ &\quad + y_{4U}(k-64) + y_{4L}(k), \\ y'(k) &= |y_{4U}(k-192)|^2 - |y_{4L}(k-128)|^2 \\ &\quad + |y_{4U}(k-64)|^2 + |y_{4L}(k)|^2. \end{aligned} \quad (2)$$

Vectorization of the Golay correlator becomes relatively straightforward when P successive output symbols $y(k), y(k+1), \dots, y(k+P-1)$ are computed in parallel. The resulting program follows the sequence of stages of (2),

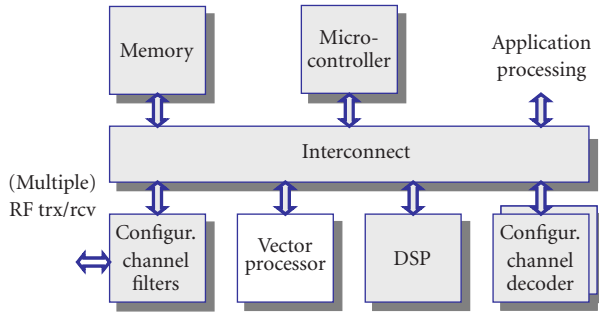

FIGURE 4: Schematic hardware architecture for SDR/BB.

where each + (or -) operation now specifies P complex additions (or subtractions), and each reference to the data memory now specifies the load (or store) of P adjacent complex samples from (or to) memory. Note that, at least for the early stages, load operations from memory may be nonaligned. That is, the load address need not be an integer multiple of P .

In summary, so-called “inner-loop vectorization” of the Golay correlator is cumbersome, whereas “outer-loop vectorization” is rather straightforward. This is typical for algorithms for which successive output values can be computed independently. Similar results apply to many kinds of FIR filters.

3.2. Rake receiver for UMTS-FDD

Rake receivers are commonly used for (W)CDMA, because of their ability to combine signals from multiple delay paths. On a conceptual level (Figure 5), a UMTS rake receiver consists of

- (i) a delay line to compensate the various path delays,
- (ii) a so-called *master rake* to receive the common pilot channel to perform channel estimation, frequency-offset estimation, and code tracking,
- (iii) a number of so-called *slave rakes* to receive the various UMTS data channels and control channels, and
- (iv) a scaler and quantizer to reduce the dynamic range before entering the channel decoder.

The master rake controls the channel-dependent parameters (path attenuation, phase distortion, frequency offset, and time synchronization) of the slave rakes. Each master rake finger includes a channel estimator, a frequency offset estimator, and a delay locked loop (code tracker). Using the known pilot signal, these blocks can reconstruct the path characteristics of the mobile channel.

Each slave rake (3) consists of F rake fingers (i.e., the F inner summations), each of which is tuned to a different delay path $T - \tau_p$ of the same physical channel. Each finger performs the inverse function of the spreading performed by the transmitter. First, the path-dependent channel delay is compensated using a delay line. Then, the signal is decorrelated with the complex conjugate of the spreading code $c(k, i)$, and accumulated over the same spreading factor S used by the

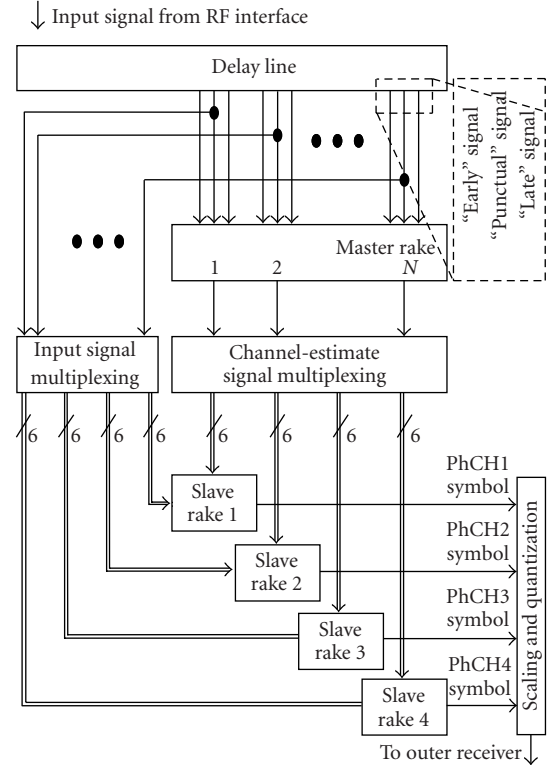

FIGURE 5: UMTS rake receiver (simplified).

transmitter. These steps (called decorrelation and “integrate and dump”) are referred to as despreading. Finally, the signals of the F fingers are weighted and combined to improve the bit error rate at the output of the slave rake:

$$y(k) = \sum_{p=0}^{F-1} w_p^*(k) \times \sum_{i=0}^{S-1} c^*(k, i) \times x(k \cdot S + i + T - \tau_p), \quad (3)$$

$$c(k, i) = c_{\text{scr}}(k \cdot S + i) \times c_{\text{ch}}(i),$$

where

- (i) y is the output signal (symbols),
- (ii) k is the symbol time,
- (iii) x is the input signal (chips),
- (iv) F is the number of delay paths (fingers),
- (v) w_p is the weight factor for path p ,
- (vi) S is the spreading factor,
- (vii) c_{scr} is the scrambling code,
- (viii) c_{ch} is the channelization code,
- (ix) T is the delay line length,
- (x) τ_p is the delay of path p .

Three scenarios for vectorization of the slave rake will be explored: symbol parallelism, finger parallelism, and chip parallelism.

With the symbol parallelism scenario (“block processing” in [5]) P successive output symbols are computed in parallel, similar to the outer-loop vectorization of the Golay correlator. For this scheme to work,

- (i) P different phases of the spreading-code generator must be computed in parallel, with a distance of S code-chips between two successive phases;
- (ii) the incoming data x must be laid out such that P values with stride S can be read simultaneously.

Both requirements are hard to satisfy, especially if different rakes operate with different spreading factors. The main problem, however, is that the latency scales with $P \times F \times S$. This latency can become prohibitive for large S , and is fatal for the UMTS fast power-control loop. For this reason, Walther [5] proposes a combination of symbol parallelism (for small F and for the pilot channel) and finger parallelism (for large S).

With finger parallelism, $\min(P, F)$ rake fingers are computed in parallel (the outer summation), one data chip at a time. This scheme requires F different phases of the spreading-code generator, where each phase corresponds with a path delay. The data chips are read sequentially, resulting in a considerable overhead, especially for small F and small S [5]. Furthermore, vector parallelism is limited to F , and hence does not scale with P . For F , a maximum value of six is often quoted, but under favorable conditions lower values are practical, and beneficial for low power consumption.

With chip parallelism, we have arrived at the innermost loop of (2), and we will aim at exploiting vector parallelism within a single rake finger [6, 7]. We assume for the moment that $S = 2^M P$ for some integer M . The spreading-code generator now has to produce P successive code chips in parallel. Unlike the rake solutions based on finger and symbol parallelism, the code generator must also *leap* by P symbols at a time. A solution with a high throughput (300 MHz), and a low set-up time (few clock cycles) is described in [8]. With the input sample phases separated in memory, P data chips can be read in parallel as adjacent, nonaligned complex samples.

Since the active fingers are processed sequentially, the processor load is proportional to F . Furthermore, chip parallelism scales well with P , that is, a wider data path yields a proportionally lower load. The latency is determined by the number of symbols K processed in the inner loop of the algorithm. For example, with $K \times S$ bounded to 512 chips, the resulting latency can comfortably accommodate UMTS power control.

Unlike symbol and finger parallelism, chip parallelism requires so-called intravector addition. That is, the inner summation of (3) must support the summation of P complex values in a single instruction [6]. The case $S < P$ is identical, except that the intravector addition produces P/S symbols.

3.3. Symbol-timing estimation for 802.11a

The symbol-timing estimation, also referred to as clear channel assessment (CCA), incorporates a *rough* symbol-timing estimation procedure in the 802.11a WLAN standard. It serves as a final preamble indicator by detecting the transition between the short and the long symbol field. If an 802.11a preamble is confirmed, *fine* symbol-timing estimation is performed on the long symbol portion by

frequency-domain processing [9]. Below, we address the rough symbol estimation.

The rough symbol-timing estimator performs two tasks:

- (1) it indicates the presence of an 802.11a preamble by detecting its unique transition from a short symbol sequence to a long symbol sequence,
- (2) it estimates the start of the long symbol field with an accuracy of ± 31 samples.

Based on extensive simulation it was chosen to base the estimation on the calculation of two sliding vector products, called autocorrelator functions (ACFs). The ACFs are compared by a threshold, which avoids division. The first ACF called *acf16* tracks the end of the short symbol field according to the metrics:

$$A_{16}(k) = \sum_{i=k-31}^k r^*(i)r(i-16), \quad (4)$$

$$P_{32}(k) = \sum_{i=k-31}^k |r(i)|^2. \quad (5)$$

Those can be iterated as

$$A_{16}(k) = A_{16}(k-1) + r^*(k)r(k-16) - r^*(k-32)r(k-48), \quad (6)$$

$$P_{32}(k) = P_{32}(k-1) + |r(k)|^2 - |r(k-32)|^2. \quad (7)$$

Their combination yields the detection indicator

$$I_{16}(k) = |A_{16}(k)|^2 - T_l P_{32}(k)P_{32}(k-16), \quad (8)$$

$$\hat{k}_{64} = \min(k \mid I_{64}(k) > 0), \quad (9)$$

where the value of T_l depends on the SNR. A short symbol field has a period of 16 samples, and hence also of 64 samples. To remove this ambiguity, $I_{16}(k)$ is calculated. If $I_{16}(k) < 0$, that is, there is no autocorrelation with a period of 16, the computation of a similar ACF is started to detect the beginning of the long symbol field with a period of 64.

Outer-loop vectorization, that is, computing P outputs in parallel, can be applied to *acf16* (5), to power computation (7), and to the detection indicator (8). The minimum value of this indicator \hat{k}_{16} , its index k , and the break condition (9) have to be computed sequentially. This can be done on the fly, that is, *in parallel* with the vector operations above.

3.4. Fast Fourier transform

The FFT is one of the fundamental DSP algorithms. Together with its inverse, it is a key algorithm for OFDM standards such as 802.11a (cf. Section 6.1). The basic computation of a radix-2 FFT is the butterfly applied to pairs of complex samples, say, 2×12 bits:

$$\begin{aligned} y_0 &= x_0 + \omega \times x_1, \\ y_1 &= x_0 - \omega \times x_1, \end{aligned} \quad (10)$$

where ω is a complex root of unity. An $N = 2^n$ point FFT is generally organized as a cascade of n stages each comprising $N/2$ butterflies. On a vector processor, a group of $P/2$ butterflies can be computed in parallel conveniently, assuming $N \geq 2P$. Depending on the particular FFT algorithm and on the stage, the two input vectors of such a group can be plain output vectors of different groups of the preceding stage, or permutations thereof. Such permutations (a.k.a. vector shuffles) must be supported in an SDR vector processor.

Most FFT algorithms require a presorted input block, or require some postsorting of the output block (bit-reversal or digit reversal). So-called self-sorting FFTs [10] avoid this, and can lead to particularly efficient vectorized FFT solutions.

3.5. Viterbi decoding

Viterbi decoders are probably the most common channel decoders for convolutional codes. They are rather computationally intensive and comprise two distinct types of computation: trellis construction and trace back. Trellis construction allows fairly straightforward vectorization, assuming the availability of vector permutations, similar to those used for FFT. Trace back, however, is inherently sequential, requiring scalar read accesses into the trellis stored in the vector memory.

For small constraint lengths of the convolutional code, or for large P , trace back tends to take more time than trellis construction. In practice, the two may well be in balance. Hence, ideally, both types of computation can be scheduled in parallel on the vector and scalar parts of a vector processor [11].

3.6. SDR vector processor requirements

From the vectorized baseband kernels above we can now collect the requirements for an SDR vector processor.

- (R1) In addition to the 16-bit data types common for DSPs, 8-bit data types are useful for the incoming radio signals. They allow a higher memory density, and twice the parallelism in the SIMD data path. Support for complex arithmetic will benefit all presented kernels, except the Viterbi decoder.
- (R2) Vectorization of most presented algorithms scale well with P . In practice, a limit will occur for 64 complex samples for the 802.11a algorithms. As shown later on, a much narrower machine will cover many of today's standards. In order to be prepared for future evolution, including multitasking, it is valuable to keep the vector processor *scalable*, that is, to parameterize its architecture and its implementation (including tools) by P .
- (R3) Orthogonal to pure SIMD parallelism, VLIW (very long instruction word [12]) parallelism can further accelerate the rake (pipelined memory access + code generation + decorrelation + integration, Section 3.2) as well as the FFT (a pipelined multiply + add/subtract + shuffle, Section 3.4).
- (R4) The speed-up that can be achieved by combining vector and VLIW parallelism is limited by the fraction of

the program code that can be vectorized. This limitation is known as Amdahl's law [12]. For example, when 90% of an algorithm can be sped up by a factor $P = 32$, the overall speed-up is less than a factor eight! In order to counter this limitation, a parallel speed-up is *also* required for the nonvectorizable parts of an algorithm. Examples of the latter were the minimum/index calculations of the symbol-timing estimator (Section 3.3) and the trace-back function of the Viterbi decoder (Section 3.5). To further counter Amdahl's Law, parallel address calculations and loop control are critical, even more so than for traditional DSPs [13].

- (R5) Beyond "pure" SIMD, shuffling of data within a vector [14] is key to both FFT (Section 3.4), and Viterbi trellis construction (Section 3.5). Furthermore, such a shuffle operation can support vector rotation, which can be used to implement nonaligned read access to vector memory as required, for example, for Golay correlation (Section 3.1) and rake reception (Section 3.2).
- (R6) Also intravector operations (a.k.a. vector reductions) are important, for example, for rake integration (Section 3.2).
- (R7) A useful, but rather CDMA-specific capability is the "generate the next P successive code chips" instruction for a variety of composite codes.
- (R8) As we aim at handheld devices, small silicon area (including data and program memories) is essential, as well as low power consumption.
- (R9) The processor must be conveniently programmable, supported by effective and efficient tools.

Note that (R2), (R3), and (R4) deal with computational performance (*effective* number of operations per second), and that (R5), (R6), and (R7) deal with functional capabilities.

4. VECTOR PROCESSORS: OnDSP AND EVP

As we have seen in Section 3, vector processing can be used to exploit the abundant and often regular parallelism encountered in many baseband algorithms. Using SIMD instructions (single-instruction multiple-data) arithmetic operations or load/store operations can be applied to P (e.g., $P = 16$) samples in parallel.

The basic features of a vector-processor suitable for SDR are listed below, with reference to Figure 6 and the requirements of Section 3.6 (R_n).

- (i) The dominant data size is 16 bits as in conventional DSPs, with some support for 8-bit and 32-bit data. Hence a single SIMD vector comprises P 16-bit elements, $2P$ 8-bit elements, or $P/2$ elements of 32 bits. Accumulator registers have extension bits to support high-resolution accumulation. The main data types are integer and fixed point, with support for complex numbers (2×8 or 2×16 bits) (R1).
- (ii) The vector memory supports one vector read or vector write (P words) per clock cycle.

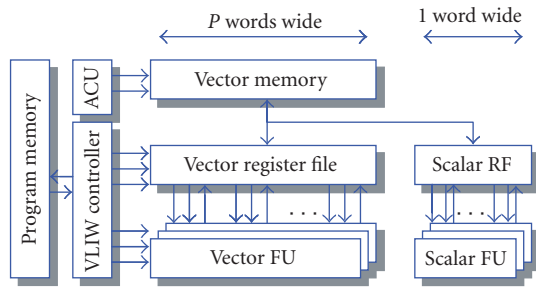

FIGURE 6: A generic vector-processor architecture.

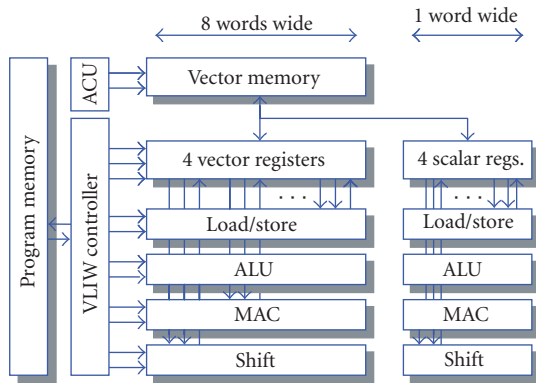

FIGURE 7: The OnDSP architecture.

- (iii) The VLIW execution model supports parallelism among multiple vector functional units (FUs), for example, MAC, ALU. This VLIW parallelism comes *in addition to* vector parallelism (R3).
- (iv) *On top of that* a VLIW instruction may *also* specify several operations on scalar functional units (R4).
- (v) To keep many functional units busy, there is extensive support for address calculations (ACUs, e.g., postincrement, modulo) and for zero-overhead looping (R4).

Compared to other programmable architectures, SIMD execution results in low power consumption (R8), because the “overhead” of address calculations, address decoding, instruction fetching/decoding, and control is shared by P operations. A similar reasoning holds for silicon area per MOPS.

With the above in common, two vector processor instances have been developed within Philips: OnDSP targeting WLAN, and EVP targeting 3G and beyond.

4.1. OnDSP

The OnDSP vector processor is a key component of several multistandard programmable wireless LAN baseband product ICs [15]. The application of vector processing to WLAN will be addressed in Section 6.1.

The OnDSP architecture is depicted in Figure 7. The vector size equals $P = 8$ (128 bits). A single VLIW instruction can specify a number of vector operations, for example, load/store, ALU, MAC, address calculations, and

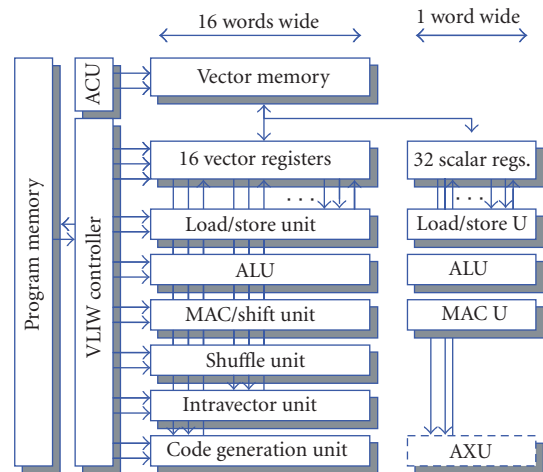

FIGURE 8: The EVP architecture.

loop-control ((R3), (R4)). OnDSP supports a couple of specific vector instructions, including word insertion/deletion, sliding, and gray coding/decoding. Data addresses must be a multiple of P . Program code is compressed vertically (“tagged VLIW” [16]).

In a 0.12 μm CMOS process, OnDSP measures about 1.5 mm^2 (250 kgates), runs 160 MHz (worst-case commercial), and dissipates about 0.8 mW/MHz including a typical memory configuration (R8). A macroassembler is used for VLIW scheduling, although optimization by hand is used for critical code.

4.2. EVP

The EVP (embedded vector processor) is a productized version of the CVP [7]. Although originally developed to support 3G standards, the current architecture proves to be highly versatile. Care has been taken to cover the OnDSP capabilities for OFDM standards.

The EVP architecture is depicted in Figure 8. The main word width is 16 bits, with support for 8-bit and 32-bit data (R1). The EVP supports multiple data types, including complex numbers (R1). For example, a complex vector multiplication uses P multipliers to multiply $1/2p$ complex numbers each two clock cycles.

The SIMD width is scalable (R2), and has been set to $P = 16$ (256 bits) for the first product instance EVP_{16} . The maximum VLIW-parallelism available equals five vector operations *plus* four scalar operations *plus* three address updates *plus* loop-control. Specific FUs of the EVP include the following ((R3), (R4)).

- (i) The shuffle unit can be used to rearrange the elements of a single vector according to an arbitrary pattern (R5).
- (ii) The intravector unit supports operations such as add (or take the maximum of) the elements of a single vector, possibly split in, M segments of P/M elements each (R6), with M a power of 2.

TABLE 2: Load (MHz) of a UMTS-FDD rake finger.

Processor	Ref.	Load (MHz)	Arithmetic resources (<i>complex arithmetic</i>)
EVP ₁₆	[7]	0.5	16×(MAC+ ALU + PN gen.)
Tigersharc	[6]	1	2 × 8×(MAC+ ALU)
4 UMTS DP	[18]	6	4×(MAC+ ALU + PN gen.)
UMTS DP	[18]	25	1×(MAC+ ALU + PN gen.)
TI C62	[19]	40	–
Carmel	[18]	125	2 MAC + ALU
TI C54x	[18]	300	1 MAC/ALU

(iii) The code generation unit supports CDMA-code generation: in a single clock cycle 16 successive complex code chips are generated (R7). The unit can be configured for a variety of codes (UMTS, CDMA2000, GPS, etc.) and for cyclic redundancy checks (CRC).

In a 90 nm CMOS process, the EVP₁₆ core measures about 2 mm² (450 kgates), runs 300 MHz (worst-case commercial), and dissipates about 0.5 mW/MHz (core only) and 1 mW/MHz including a typical memory configuration (R8). These numbers are based on gate-level simulations of annotated netlists.

Programs are written in EVP-C, a superset of ANSI-C. Programs written in plain C will be mapped on the scalar part of the EVP, and hence will not utilize the vector FUs. The extensions include vector data types and function intrinsics for vector operations, all in a C-like syntax. The EVP-C compiler takes care of register allocation (scalar and vector registers) as well as VLIW instruction scheduling (scalar and vector operations combined). The EVP tool flow (R9) further comprises an EVP-C host-emulation library, a linker, a bit-true/cycle-true simulator, a profiler, and an integrated debugger.

5. RESULTS FOR BASEBAND KERNELS

The results of mapping the baseband kernels of Section 3 onto the vector processors of Section 4 are presented below, together with relevant benchmarking.

5.1. Golay correlator for UMTS-FDD

On the EVP₁₆ as many as $1/2p = 8$ complex additions/ subtractions (2×16 bit) can be computed in parallel. Automatic scheduling of the EVP-C version of the Golay correlator on the EVP₁₆ requires 22 cycles for $1/2p$ symbols. Manual optimization of the memory accesses and schedule reduces this to 16 cycles for $1/2p$ symbols. Note that the 16 adders are busy for 13/16 of the time (Section 3.1). Assuming correlation on two sample phases of 4 MHz each, the EVP₁₆ load becomes $2 \times 4.10^6 \times 16$ cycles / ($1/2p = 8$), or approximately 16 MHz.

5.2. Rake receiver for UMTS-FDD

On the EVP the inner loop of the rake (Section 3.2) keeps most FUs busy. A single EVP VLIW instruction ($1/f_c$ throughput) specifies

- (i) load and align a sample vector of P data chips,
- (ii) auto increment by P of the pointer to these chips,
- (iii) generate a vector of the next P code chips,
- (iv) correlate a vector of data and a vector of code chips,
- (v) intra-add result to one or few symbols ($S \leq P$) or to one partial symbol ($S > P$).

For the UMTS-FDD chip rate of 3.84 MHz this implies an EVP₁₆ load of about 0.3 MHz per rake finger for the chip-rate processing (3), including loop preambles and postambles for blocks of 512 chips. Including some symbol-rate processing this will increase to 0.4-0.5 MHz, depending on the spreading factor.

Table 2 summarizes the load (MHz) of a rake finger on various programmable DSPs.

5.3. Fast Fourier transform

Both OnDSP and EVP exploit pipeline parallelism (implemented by means of VLIW) among

- (i) a complex vector multiplication,
- (ii) a vector addition/subtraction, and
- (iii) a vector permutation (between the butterfly stages).

For a complete 64-point FFT, the OnDSP and EVP₁₆ require 160 and 64 cycles, respectively, based on manually scheduled code. Normalized on the respective processor SIMD widths ($P = 8$ and $P = 16$), EVP₁₆ is somewhat faster because its add/subtract instruction allows implicit scaling between stages. Note that all 16 EVP₁₆'s multipliers are active during 48/64 clock cycles!

The prototype EVP-C compiler requires 79 cycles, about 25% more than the hand-scheduled assembly code.

Table 3 shows the cycle counts for a 64-point FFT (incl. bit-reversal) for a number of DSPs. The numbers from [17] have been scaled from a 256-point FFT in proportion to the number of butterflies. The column "code" specifies whether the program has been compiled "out-of-the-box", that is, without any manual intervention, or whether it has been hand optimized at the assembly level.

5.4. Viterbi and turbo decoding

The EVP allows parallel computation of trellis construction on the vector FUs, and trace back (on the scalar FUs) [11]. Table 4 benchmarks several DSPs for a 12 kbps UMTS

TABLE 3: Cycle counts for a 64-point FFT.

Processor	Ref.	Code	Clock cycles	SIMD
EVP ₁₆	–	Optimized	64	16 × 16
OnDSP	–	Optimized	160	8 × 16
Tigersharc	[6]	Optimized	174	2 × 8 × 16
VIRAM	–	Optimized	357	16 × 32
TMS320C6203	[17]	Optimized	646	N.A.
AltiVec MPC7447	[17]	Optimized	956	8 × 16
Carmel 10xx	[17]	Out-of-the-box	5568	N.A.
AMD K6-2E+/ACR	[17]	Out-of-the-box	10 751	N.A.

TABLE 4: Viterbi and turbo decoding on several DSPs.

Processor	Ref.	Viterbi		Turbo
		Cycles /symbol	Butterflies /cycle	Cycles /symbol
EVP ₁₆	[7, 11]	37	3.5	55
Tigersharc	[6]	70	1.8	70
TMS320C64	[20]	170	0.8	440
AltiVec	[14]	260	0.5	–

AMR voice channel (constraint length $K = 9$). The 3.5 butterfly operations/clock cycle for EVP₁₆ translates to 10 cycles/symbol for a decoder with constraint length 7.

Table 4 also provides load numbers for turbo decoding (3 GPP, with 6 iterations). The EVP₁₆ cycle count is an estimate, based on hand schedules.

6. SDR RESULTS

In the preceding sections we have presented a vector-processor architecture for SDR using several baseband algorithms from the UMTS and WLAN domain as drivers. In addition to its efficiency for isolated algorithms, the resulting architecture (cf. Figure 4) needs to be assessed in an overall system context.

6.1. Wireless LAN

The Philips 802.11 a,b,g baseband implementation (product SA250) is based on the OnDSP vector processor [15]. Below we focus on the IEEE 802.11a standard. From Section 5.4, we can conclude that for the symbol rates at hand (up to 54 MHz) it is *not* practical to map Viterbi decoding on a vector processor. Hence, the OnDSP is employed for (de)modulation tasks, while hardware accelerators support Viterbi decoding, (de)interleaving, and de(scrambling). The main tasks for the vector processor are

- (i) preparing transmission data (TX),
- (ii) equalizing and tracking when receiving data (RX),
- (iii) burst detection and acquisition.

The OnDSP cycle counts of Table 5 yield an OnDSP load of 110 MHz. For the EVP₁₆, with twice the parallelism, this will

go down to approximately 55 MHz. In addition to meeting the OnDSP load constraint, the OnDSP can also cope with the tight real-time constraints for synchronization.

Interestingly, software flexibility does *not* increase the silicon area for this application. Unlike, for example, [21], the same hardware is used for synchronization and FFT.

6.2. UMTS-FDD

Today's GSM handsets deploy programmable DSPs for all baseband signal processing, with all the associated flexibility benefits. Moreover, it has allowed concurrent and independent evolution of DSP architectures (following Moore's law) and algorithmic improvement. Different groups of designers, often in different companies used the DSP architecture and tools as interface between them.

For 3G standards, such as UMTS, this is not entirely practical, at least for the time being. From Section 5.4 we can see that Turbo decoding alone requires about 55 clock cycles per symbol on the EVP₁₆. For UMTS 3 GPP R'99 this results in an acceptable 35 MHz load for a 640 kbps channel. For 3GPP release 5, however, a 14 Mbps data rate would result in an EVP₁₆ load in excess of 700 MHz, and a power consumption close to 1 watt in 90 nm CMOS. Accordingly, we choose the architecture of Figure 4. This hardware-software partitioning is markedly different from [22], where all channel (de) coding is also mapped on DSP software.

Furthermore, 3G+ standards show a much more dynamic computational load than 2G standards, both due to the nature of the employed algorithms and the large number of different use cases. This can be illustrated for four UMTS scenarios [3].

- (1) UMTS idle mode, only multicell synchronization.

TABLE 5: OnDSP load for the critical loop of the 802.11a (de)modulator (cycles per OFDM symbol of 4 microseconds).

OnDSP load (de)modulator task	TX (cycles)	RX (cycles)
Symbol (de)mapping	35	35
Pilot generation	55	–
Pre (post) scaling	35	35
Tracking	–	36
Channel correction	–	39
OFDM (de)mapping	35	35
Afc(I) FFT	160	160
TS frequency shift	40	–
Phase-error correction	–	39
CP insertion/removal	35	–
Control code	40	40
Overall peak load	435	414
Overall peak load (Mhz)	109	104

TABLE 6: EVP₁₆ loads for the modem stage; 4 scenarios.

UMTS task	EVP ₁₆ load (MHz)			
	1	2	3	4
PSCH search (Golay)	18	18	18	18
CPICH search	98	17	17	17
CPICH despreading	–	4	22	33
CPICH symbol rate	–	1	1	2
DCH despreading	–	3	16	16
DCH symbol rate	–	1	6	6
HS-SCCH despreading	–	–	–	15
HS-SCCH symbol rate	–	–	–	1
HS-DSCH despreading	–	–	–	12
HS-DSCH symbol rate	–	–	–	22
Overall peak load	116	44	80	142
Overall average load	4	28	64	126

- (2) UMTS R'99 connected mode with flat fading conditions (1 rake finger only), 3 dedicated channels (DCH), and neighbor-cell broadcast channel (BCH) monitoring.
- (3) UMTS R'99 connected mode in a scattering environment with multiple paths (six rake fingers) with the same transport channel configuration as before.
- (4) UMTS R'99 connected mode in a scattering environment with multiple paths (six rake fingers) with the same transport channel configuration plus an HSDPA (high speed downlink packet access) link (3GPP R5) with 15 downlink channelization codes.

The EVP₁₆ load numbers for these four scenarios, based on simulation of kernels, are summarized in Table 6. Note the variation in load distributions! More advanced receiver algorithms such as interference cancellation, chip-rate equalization, or joint detection will be required in the future, both to increase the system capacity and to improve the reception

quality. This is, from our point of view, one of the most compelling justifications for SDR.

6.3. Multistandard considerations

EVP₁₆ load numbers for the modem stage for various wireless standards are shown in Figure 9. Note the considerable headroom available on EVP₁₆ for most standards.

The available headroom can be used to

- (i) introduce improved but more demanding algorithms,
- (ii) scale the supply voltage to reduce power consumption, and, in principle,
- (iii) run multiple standards simultaneously.

The latter introduces intrastandard resource sharing, substantially reducing the additional costs for adding a radio standard. For the combination of WLAN and UMTS, including intersystem handover, this is illustrated in Figure 10. Supporting multiple standards simultaneously requires a carefully coordinated use of the resources in the SDR architecture of Figure 4.

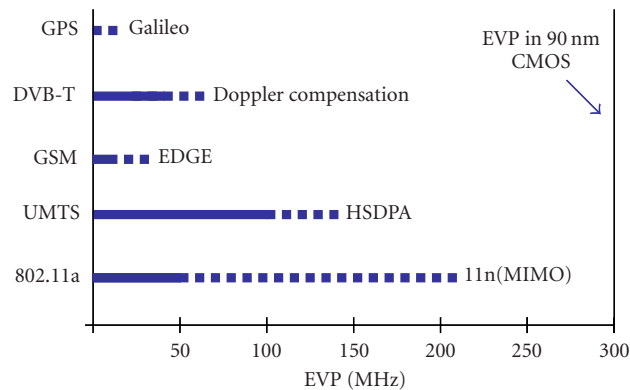

FIGURE 9: Estimated EVP₁₆ load numbers for the modem stage of various receivers.

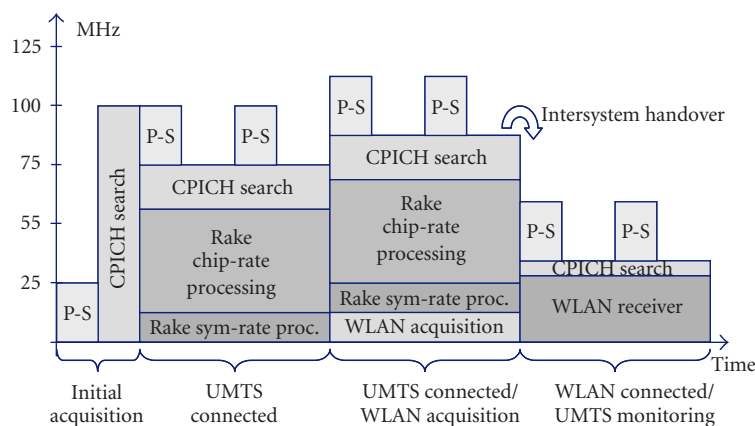

FIGURE 10: Handover from UMTS to WLAN, with load indications for the EVP₁₆. P-S = PSCH search.

7. CONCLUSION

The modem stage of an SDR requires software flexibility to cope with the multitude of wireless standards, their evolution, and with algorithmic improvement (including bug fixes and in-field upgrades) without the need to respin an IC. Vector parallelism in combination with VLIW can offer the computation power required for this. The OnDSP has demonstrated this for several WLAN ICs. The EVP₁₆, with its powerful FUs (shuffle, intravector, code generation) outperforms conventional DSPs by an order of magnitude or more, in a power-efficient way. Accordingly, the EVP₁₆ can be a key component of an SDR, where it can save silicon area by both intrastandard and interstandard reuse. With 300 MHz, the EVP₁₆ can potentially handle multiple standards simultaneously.

ACKNOWLEDGMENT

The contributions of Srinivasan Balakrishnan, Nur Engin, Rick Nas, and Rob Takken (all with Philips Research Labs), and of Wim Kloosterhuis, Jean Paul Smeets, and Mahima Smriti (all with Philips Semiconductors) are gratefully acknowledged.

REFERENCES

- [1] R. Becher, M. Dillinger, M. Haardt, and W. Mohr, "Broadband wireless access and future communication networks," *Proc. IEEE*, vol. 89, no. 1, pp. 58–75, 2001.
- [2] R. Kokozinski, D. Greifendorf, J. Stammen, and P. Jung, "The evolution of hardware platforms for mobile 'software defined radio' terminals," in *Proc. IEEE 13th International Symposium on Personal, Indoor and Mobile Radio Communications (PIMRC '02)*, vol. 5, pp. 2389–2393, Lisbon, Portugal, September 2002.
- [3] 3GPP TS 25.211, "Physical channels and mapping of transport channels onto physical channels (FDD) - (Release 5)," v. 5.5.0 (2003-09).
- [4] 3GPP TS 25.213, "Spreading and modulation (FDD) - (Release 5)," v. 5.5.0 (2003-12).
- [5] U. Walther, "Signalprozessarchitekturen für den Mobilfunk der 3. Generation," Ph.D. Dissertation, Technische Universität Dresden, Germany, 2002.
- [6] J. Fridman and Z. Greenfield, "The TigerSHARC DSP architecture," *IEEE Micro*, vol. 20, no. 1, pp. 66–76, 2000.
- [7] K. van Berkel, P. P. E. Meuwissen, N. Engin, and S. Balakrishnan, "CVP: a programmable Co vector processor for 3G mobile baseband processing," in *Proc. World Wireless Congress (WWC '03)*, San Francisco, Calif, USA, May 2003.
- [8] R. J. M. (Rick) Nas and K. van Berkel, "High-Throughput, Low Set-up Time Reconfigurable Linear Feedback Shift Register," Philips PR-TN-2004/00899.

- [9] B. Stantchev, *An approach to synchronized detection in DFT-based receivers*, Ph.D. thesis, Shaker Verlag, Aachen, Germany, 2002.
- [10] F. Arguello, J. D. Bruguera, and E. L. Zapata, "A parallel architecture for the self-sorting FFT algorithm," *Journal of Parallel and Distributed Computing*, vol. 31, no. 1, pp. 88–97, 1995.
- [11] N. Engin and K. van Berkel, "Viterbi decoding on a coprocessor architecture with vector parallelism," in *Proc. IEEE Workshop on Signal Processing Systems (SIPS '03)*, pp. 334–339, Seoul, Korea, August 2003.
- [12] J. L. Hennessy and D. A. Patterson, *Computer Architecture: A Quantitative Approach*, Morgan Kaufmann, San Francisco, Calif, USA, 3rd edition, 2003.
- [13] P. Lapsley, J. Bier, A. Shoham, and E. A. Lee, *DSP Processor Fundamentals: Architectures and Features*, Berkeley Design Technology, Fremont, Calif, USA, 1994–1996.
- [14] L. Gwennap, "G4 is first PowerPC with altivec," in *Microprocessor Rep.*, pp. 17–19, November 1998.
- [15] J. Kneip, M. Weiss, W. Drescher, et al., "Single chip programmable baseband ASSP for 5 GHz wireless LAN applications," *IEICE Transactions on Electronics*, vol. E85-C, no. 2, pp. 359–367, 2002.
- [16] M. Weiss and G. P. Fettweis, "Dynamic codewidth reduction for VLIW instruction set architectures in digital signal processors," in *Proc. 3rd International Workshop on Signal and Image Processing (IWSIP '96)*, pp. 517–520, Manchester, UK, November 1996.
- [17] Embedded Microprocessor Benchmark Consortium. <http://www.eembc.com/>.
- [18] U. Walther, F. Tischer, and G. P. Fettweis, "New DSPs for next generation mobile communications," in *Proc. Global Telecommunications Conference (GLOBECOM '99)*, vol. 5, pp. 2615–2619, Rio de Janeiro, Brazil, December 1999.
- [19] P. R. Dent, "W-CDMA reception with a DSP based software radio," in *Proc. 1st International Conference on 3G Mobile Communication Technologies*, pp. 311–315, London, UK, March 2000.
- [20] T. Horner and J. Nikolic-Popovic, "Application of TMS320-C6400 in 3G Wireless Infrastructure Transceiver," 2000, <http://focus.ti.com/pdfs/univ/01-Wireless.pdf>.
- [21] T. H. Meng, B. McFarland, D. Su, and J. Thomson, "Design and implementation of an all-CMOS 802.11a wireless LAN chipset," *IEEE Commun. Mag.*, vol. 41, no. 8, pp. 160–168, 2003.
- [22] J. Glossner, D. Iancu, J. Lu, E. Hokenek, and M. Moudgill, "A software-defined communications baseband design," *IEEE Commun. Mag.*, vol. 41, no. 1, pp. 120–128, 2003.

Kees van Berkel is a Fellow at Philips Research Laboratories, Eindhoven. He received an M.S. degree (cum laude) in electrical engineering from the Delft University of Technology in 1980 and a Ph.D. degree in 1992 from the Technical University Eindhoven (TU/e). Since 1996, he has been a Visiting Professor at the Department of Mathematics and Computer Science, Technical University Eindhoven (TU/e). From 1986 until 2000, he led the team that pioneered the synthesis, test, and application of asynchronous VLSI circuits based on handshake circuits. He contributed more than 25 scientific publications, 7 patents, and the book *Handshake Circuits*. Today, these circuits find application in ICs for pagers, corded phones, contactless smartcards, controllers, and more. During the late 1990s, his research focus moved to architectures for mobile wireless terminals.



He initiated and coarchitected the CVP, the predecessor of the EVP. His current research interests include software-defined radio, signal processing algorithms, vector processing, VLSI architectures, DSP architectures, memory architectures, and interconnect-centric device architectures.

Frank Heinle was born in 1968. He received his Dipl.-Ing. (M.S.) degree and Dr.-Ing. (Ph.D.) degree from the University of Erlangen, Germany, in 1994 and 1998, respectively. From 1994 to 1997, he was working as a Research Assistant at the University of Erlangen on multirate signal processing. Since 1997, he has been with Philips Semiconductors, Nuernberg, Germany, working on signal processing and baseband architectures for various mobile communication systems including IS-136, UMTS, and TD-SCDMA. His research interests include mobile communications, software-defined radio, signal processing algorithms and architectures.

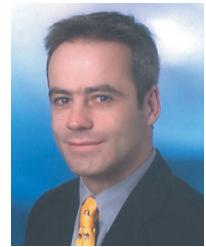

Patrick P. E. Meuwissen received his M.S. degree in information technological science from the Faculty of Electrical Engineering, Technical University Eindhoven (TU/e) in 1997. Currently, he is a Senior Scientist in the Embedded Systems Architectures on Silicon Group, Philips Research Laboratories, Eindhoven, The Netherlands. There, he coarchitected the CVP, the predecessor of the EVP. He was also heavily involved in the creation of the initial CVP tools, and used these to perform the first algorithm mapping experiments. In February 2005, he completed his studies at the Philips Research "Architecture School." His current research interests include system architecture, embedded system design, hardware-software codesign, and VLSI systems for new multimedia applications like 3DTV.



Kees Moerman is currently working as Chief Architect in the DSP Innovation Center, Philips Semiconductors. As such, he is responsible for the technical roadmap of the DSP cores as used in, for example, the Nexpria Mobile architecture, including "classical" DSP cores as reacquired from Adelante Technologies, and the new vector processing core architecture as described in this paper. Before joining Philips Semiconductors in 1995, he worked for 10 years at Pijnenburg Micro-electronics BV, The Netherlands, on the design of embedded microcontroller and DSP cores, and the corresponding software development environments and tools. He holds an M.S. degree in physics and information technology which he received from the Utrecht University, The Netherlands, and has 15+ years of experience in DSP architecture and design.



Matthias Weiss received his M.S.Sc./Dipl.-Ing. degree in electrical engineering from Berlin University of Technology, Germany, and his Ph.D. degree from Dresden University of Technology, Germany, in 1995 and 2003, respectively. Since 1992, he has been involved in DSP architectures and his Ph.D. thesis discussed a framework for automating the design of digital signal processors.



In 1999, he cofounded Systemonic, a fabless WLAN company, where he headed the DSP Architecture Group and developed the OnDSP platform, the core of the company's WLAN baseband IC. After the acquisition of Systemonic by Philips in 2002, he worked in the EVP Architecture Definition Team. Since 2003, he has been heading the ultra-wideband (UWB) baseband development. His research interests are digital signal processing algorithms, DSP and microprocessor architectures, and DSP design automation. He holds the Erwin-Kirch Award, is Member of the IEEE, and authored more than 20 papers and patents in the field of DSP processing, inventing the productized TVLIW compression scheme and scalable DSP architecture OnDSP. He is Manager of the System Architecture Team in Philips Semiconductors, Dresden.

Special Issue on Cross-Layer Design for the Physical, MAC, and Link Layer in Wireless Systems

Call for Papers

Motivation

Cross-layer design is a common theme for emerging wireless networks, such as cellular systems and ad hoc networks, though the objectives and requirements can be very different. A cross-layer approach is particularly important when designing protocols at the physical (PHY) and medium access control (MAC)/link layer for several reasons. The past decade gave birth to innovative techniques such as opportunistic communication, rate adaptation, and cooperative coding, which all require close interaction between layers. For example, optimizing the rate-delay tradeoff in a multiuser wireless system requires knowledge of PHY parameters such as channel state information (CSI) as well as delay information from the MAC. As another example, the notion of link in wireless relay systems is generalized towards a collection of several physical channels related to more than two nodes. The potential for novel solutions through cross-layer design is further seen in the fact that it motivates collaboration among researchers of different specialties, such as antennas and propagation, signal processing, error-control coding, scheduling, and networking (MAC) protocols.

This special issue is devoted to research efforts that use cross-layer design to jointly optimize the lowest two layers of the wireless communication systems. Such cross-layer solutions will have decisive impact in future wireless networks.

Contributions on the following and related topics are solicited:

- Random access protocols with multipacket reception (MPR), multiantenna MPR protocols
- MAC/ARQ protocols for multiantenna and wireless relay systems
- MAC-level consideration of time-varying channels: channel estimation, channel state information (CSI), and link adaptation
- MAC-level interference mitigation via management of PHY-level multiuser networks: for example, interfering multipleaccess (MA) channels

- MAC/PHY protocols and analysis of cognitive radio networks
- MAC protocols for PHY-restricted devices/circuitry (e.g., RFID)
- PHY-aware scheduling and resource allocation
- Analysis of fundamental tradeoffs at the PHY/MAC interface: rate-delay, energy-delay
- PHY/MAC/link aspects of network coding in wireless networks
- PHY/MAC issues in wireless sensor networks and distributed source co
- Cross-layer optimization of current standards (WiMAX, W-CDMA, etc.)
- Interaction of MAC/PHY design with the circuitry and the battery management

Authors should follow the EURASIP Journal on Advances in Signal Processing manuscript format described at <http://www.hindawi.com/journals/asp/>. Prospective authors should submit an electronic copy of their complete manuscript through the EURASIP Journal on Advances in Signal Processing Manuscript Tracking System at <http://www.hindawi.com/mts/>, according to the following timetable:

Manuscript Due	February 1, 2008
First Round of Reviews	May 1, 2008
Publication Date	August 1, 2008

GUEST EDITORS:

Petar Popovski, Center for TeleInFrastructure, Aalborg University, Niels Jernes Vej 12, A5-209, 9220 Aalborg, Denmark; petarp@kom.aau.dk



Mary Ann Ingram, School of Electrical and Computer Engineering, Georgia Institute of Technology, 777 Atlantic Drive NW, Atlanta, GA 30332-0250, USA;
maryann.ingram@ee.gatech.edu

Christian B. Peel, ArrayComm LLC, San Jose, CA 95131-1014, USA; chris.peel@ieee.org

Shinsuke Hara, Graduate School of Engineering, Osaka City University, Osaka-shi 558-8585, Japan;
hara@info.eng.osaka-cu.ac.jp

Stavros Toumpis, Department of Electrical and Computer Engineering, University of Cyprus, 1678 Nicosia, Cyprus;
toumpis@ucy.ac.cy

Special Issue on Wireless Video

Call for Papers

Motivation

Video transport is becoming increasingly important for a large variety of applications and networks. Wireless information exchange will be dominated by basic human communication such as messaging, voice, and video communication. Because of its typically large bandwidth requirements, video communication will emerge as the dominant and most critical form of traffic in and beyond 3G/4G wireless systems. Digital video transmission over wireless connections has proven to be a challenging task, given the hostile communication environment, characterized by unpredictable connection quality and significant error rates, a limited available bandwidth, and severe energy constraints. When developing a reliable and effective video transmission system over a wireless-based network, many different technical problems must be addressed, some of which may be application- or network-specific.

This special issue will focus on the most recent advances in applications involving video communication over wireless links. For example, P2P or multicast streaming applications will be addressed, in which the scalability characteristics of the audiovisual codecs may be exploited to define new scheduling and prioritization algorithms for the efficient delivery of time-sensitive traffic. Video transmission over wireless LANs with critical bandwidth requirements and severe energy constraints, such as sensor networks, will also be addressed.

List of Topics

Papers on the following and related topics are solicited:

- Video coding for wireless transmission
 - Advanced video coding algorithms
 - Distributed video coding
 - Error resilience and error concealment techniques
 - Joint source-channel coding
 - Joint restoration and coding
- Video distortion estimation and quality assessment for wireless transmission
- Multiple access for wireless video

- Adaptive techniques for video delivery over wireless networks
- Cross-layer design and optimization techniques for wireless video transmission
- Quality of service support for video delivery over wireless networks
- Wireless video protocols and standards
- DVB-H and mobile TV
- Distributed wireless video communications
- Wireless P2P video streaming

Authors should follow the EURASIP Journal on Applied Signal Processing manuscript format described at the journal site <http://www.hindawi.com/journals/asp/>. Prospective authors should submit an electronic copy of their complete manuscript through the EURASIP Journal on Applied Signal Processing Manuscript Tracking System at <http://www.hindawi.com/mts/>, according to the following timetable:

Manuscript Due	October 1, 2007
First Round of Reviews	January 1, 2008
Publication Date	April 1, 2008

GUEST EDITORS:

Fulvio Babich, Dipartimento di Elettrotecnica, Elettronica ed Informatica, Università degli Studi di Trieste, 34127 Trieste, Italy; babich@units.it

David R. Bull, Department of Electrical and Electronic Engineering, University of Bristol, Bristol BS8 1UB, UK; dave.bull@bristol.ac.uk

Jianfei Cai, School of Computer Engineering, Nanyang Technological University, Singapore 639798; asjfcai@ntu.edu.sg

Avideh Zakhor, Department of Electrical Engineering and Computer Sciences, University of California, Berkeley, CA 94720, USA; avz@eecs.berkeley.edu