

# Vehicle and Mission Design Options for the Human Exploration of Mars/Phobos Using “Bimodal” NTR and LANTR Propulsion

Stanley K. Borowski and Leonard A. Dudzinski  
Glenn Research Center, Cleveland, Ohio

Melissa L. McGuire  
Analex Corporation, Brook Park, Ohio

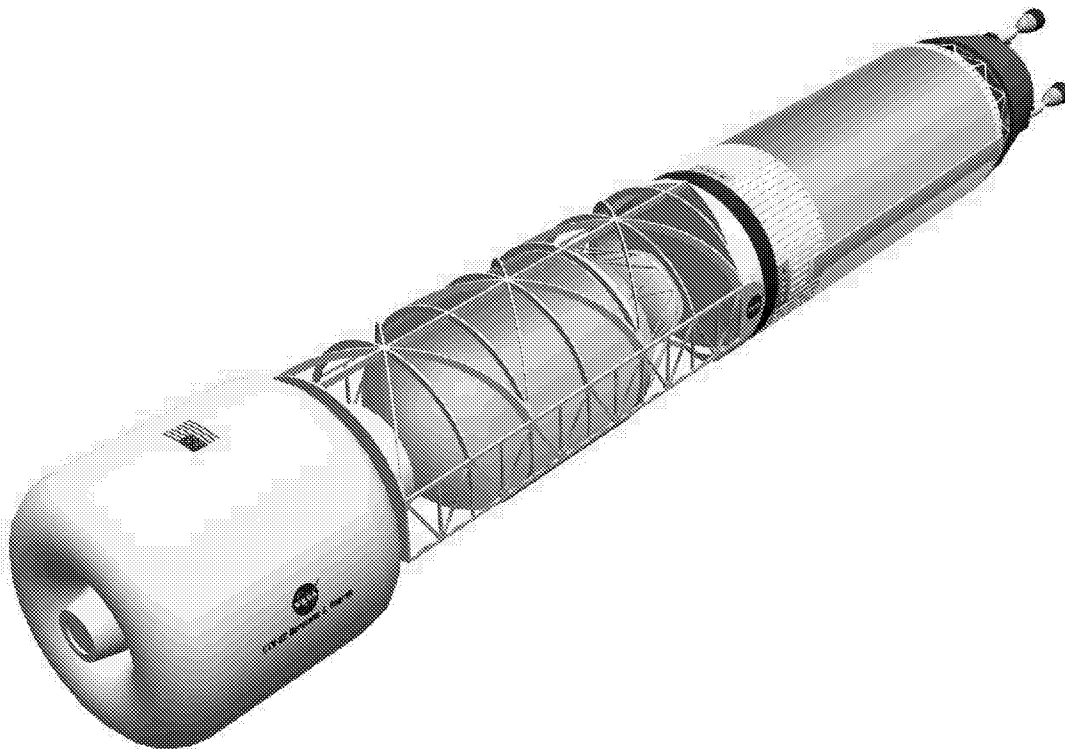

## The NASA STI Program Office . . . in Profile

Since its founding, NASA has been dedicated to the advancement of aeronautics and space science. The NASA Scientific and Technical Information (STI) Program Office plays a key part in helping NASA maintain this important role.

The NASA STI Program Office is operated by Langley Research Center, the Lead Center for NASA's scientific and technical information. The NASA STI Program Office provides access to the NASA STI Database, the largest collection of aeronautical and space science STI in the world. The Program Office is also NASA's institutional mechanism for disseminating the results of its research and development activities. These results are published by NASA in the NASA STI Report Series, which includes the following report types:

- **TECHNICAL PUBLICATION.** Reports of completed research or a major significant phase of research that present the results of NASA programs and include extensive data or theoretical analysis. Includes compilations of significant scientific and technical data and information deemed to be of continuing reference value. NASA's counterpart of peer-reviewed formal professional papers but has less stringent limitations on manuscript length and extent of graphic presentations.
- **TECHNICAL MEMORANDUM.** Scientific and technical findings that are preliminary or of specialized interest, e.g., quick release reports, working papers, and bibliographies that contain minimal annotation. Does not contain extensive analysis.
- **CONTRACTOR REPORT.** Scientific and technical findings by NASA-sponsored contractors and grantees.

- **CONFERENCE PUBLICATION.** Collected papers from scientific and technical conferences, symposia, seminars, or other meetings sponsored or cosponsored by NASA.
- **SPECIAL PUBLICATION.** Scientific, technical, or historical information from NASA programs, projects, and missions, often concerned with subjects having substantial public interest.
- **TECHNICAL TRANSLATION.** English-language translations of foreign scientific and technical material pertinent to NASA's mission.

Specialized services that complement the STI Program Office's diverse offerings include creating custom thesauri, building customized databases, organizing and publishing research results . . . even providing videos.

For more information about the NASA STI Program Office, see the following:

- Access the NASA STI Program Home Page at <http://www.sti.nasa.gov>
- E-mail your question via the Internet to [help@sti.nasa.gov](mailto:help@sti.nasa.gov)
- Fax your question to the NASA Access Help Desk at 301-621-0134
- Telephone the NASA Access Help Desk at 301-621-0390
- Write to:  
NASA Access Help Desk  
NASA Center for AeroSpace Information  
7121 Standard Drive  
Hanover, MD 21076



# Vehicle and Mission Design Options for the Human Exploration of Mars/Phobos Using “Bimodal” NTR and LANTR Propulsion

Stanley K. Borowski and Leonard A. Dudzinski  
Glenn Research Center, Cleveland, Ohio

Melissa L. McGuire  
Analex Corporation, Brook Park, Ohio

Prepared for the  
34th Joint Propulsion Conference  
cosponsored by the AIAA, ASME, SAE, and ASEE  
Cleveland, Ohio, July 13–15, 1998

National Aeronautics and  
Space Administration

Glenn Research Center

## Acknowledgments

The authors wish to express their thanks to GRC management (Pat Symons, Harry Cikanek, and Joe Nieberding) and NASA Headquarters (Lewis Peach) for support and encouragement during the course of this work, and to a number of individuals for key contributions to various topics addressed in this study.

They include: Don Culver (Aerojet) on bimodal CIS engine design issues, Lee Mason (NASA Glenn) on Brayton cycle PCU analysis and system characterization, Dave Plachta (NASA Glenn) on LH<sub>2</sub> thermal protection and active refrigeration systems, Mike Stancati (Science Applications International Corporation (SAIC)) on disposal  $\Delta V$  estimates, and Pat Rawlings (SAIC) for artwork depicted in Figure 2.

## Document Change History

This printing, numbered as **NASA/TM—1998-208834/REV1, December 2002**, replaces the previous version, **NASA/TM—1998-208834, December 1998**.

Nontechnical changes have been made to the text and the figures have been recreated to improve the quality.

Available from

NASA Center for Aerospace Information  
7121 Standard Drive  
Hanover, MD 21076

National Technical Information Service  
5285 Port Royal Road  
Springfield, VA 22100

Available electronically at <http://gltrs.grc.nasa.gov>

# VEHICLE AND MISSION DESIGN OPTIONS FOR THE HUMAN EXPLORATION OF MARS/PHOBOS USING “BIMODAL” NTR AND LANTR PROPULSION

Stanley K. Borowski\* and Leonard A. Dudzinski\*\*  
National Aeronautics and Space Administration  
Glenn Research Center  
Cleveland, Ohio 44135  
Phone: 216-977-7091 and 216-977-7107

Melissa L. McGuire\*\*  
Analex Corporation  
Brook Park, Ohio 44142  
216-977-7128

## ABSTRACT

The nuclear thermal rocket (NTR) is one of the leading propulsion options for future human missions to Mars because of its high specific impulse ( $I_{sp}$ ~850-1000 s) capability and its attractive engine thrust-to-weight ratio (~3-10). To stay within the available mass and payload volume limits of a “Magnum” heavy lift vehicle, a high performance propulsion system is required for trans-Mars injection (TMI). An expendable TMI stage, powered by three 15 thousand pounds force (klbf) NTR engines is currently under consideration by NASA for its Design Reference Mission (DRM). However, because of the miniscule burnup of enriched uranium-235 during the Earth departure phase (~10 grams out of 33 kilograms in each NTR core), disposal of the TMI stage and its engines after a single use is a costly and inefficient use of this high performance stage. By reconfiguring the engines for both propulsive thrust and modest power generation (referred to as “bimodal” operation), a robust, multiple burn, “power-rich” stage with propulsive Mars capture and reuse capability is possible. A family of modular “bimodal” NTR (BNTR) vehicles are described which utilize a common “core” stage powered by three 15 klbf BNTRs that produce 50 kWe of total electrical power for crew life support, an active refrigeration / reliquification system for long term, “zero-boiloff” liquid hydrogen (LH<sub>2</sub>) storage, and high data rate communications. An innovative, spine-like “saddle truss” design connects the core stage and payload element

and is open underneath to allow supplemental “in-line” propellant tanks and contingency crew consumables to be easily jettisoned to improve vehicle performance. A “modified” DRM using BNTR transfer vehicles requires fewer transportation system elements, reduces IMLEO and mission risk, and simplifies space operations. By taking the next logical step—use of the BNTR for propulsive capture of all payload elements into Mars orbit—the power available in Mars orbit grows to 150 kWe compared to 30 kWe for the DRM. Propulsive capture also eliminates the complex, higher risk aerobraking and capture maneuver which is replaced by a simpler reentry using a standardized, lower mass “aerodescent” shell. The attractiveness of the “all BNTR” option is further increased by the substitution of the lightweight, inflatable “TransHab” module in place of the heavier, hard-shell hab module. Use of TransHab introduces the potential for propulsive recovery and reuse of the BNTR / Earth return vehicle (ERV). It also allows the crew to travel to and from Mars on the same BNTR transfer vehicle thereby cutting the duration of the ERV mission in half—from ~4.7 to 2.5 years. Finally, for difficult Mars options, such as Phobos rendezvous and sample return missions, volume (not mass) constraints limit the performance of the “all LH<sub>2</sub>” BNTR stage. The use of “LOX-augmented” NTR (LANTR) engines, operating at a modest oxygen-to-hydrogen mixture ratio (MR) of 0.5, helps to increase “bulk” propellant density and total thrust during the TMI burn. On all subsequent burns, the bimodal LANTR engines operate on LH<sub>2</sub> only (MR=0) to maximize vehicle performance while staying within the lift capability of two Magnum launches.

\*Ph.D./Nuclear Engineering, Senior Member AIAA

\*\*Aerospace Engineer, Member AIAA

## INTRODUCTION AND BACKGROUND

The possible discovery of ancient microfossils in the Mars meteorite ALH84001, along with the excitement provided by the Mars Pathfinder and current Mars Surveyor missions<sup>1</sup> has stirred worldwide interest in the question of extra-terrestrial life and in NASA's plans for future human exploration missions to Mars. Over the last decade, NASA study teams have assessed a variety of mission and technology options for human exploration missions to the Moon and Mars. In FY1988, NASA's Office of Exploration sponsored four separate *Exploration Case Studies*<sup>2,3</sup> which outlined strategies for human expeditions to Phobos and Mars, a human-tended lunar observatory, and an evolutionary expansion strategy beginning with a lunar outpost and progressing to similar bases of operations on Mars and its moons. Phobos mission objectives included basic exploration, resource surveys to determine the existence of water, and the establishment of a science station. For the Mars / Phobos missions, a "split / sprint" transportation approach was utilized that predeployed cargo using "minimum-energy" trajectories to reduce propellant mass, and higher energy trajectories to reduce in-space transit times for the crew. Short stay time, opposition-class missions employing aerobraking, chemical and NTR propulsion options were also assumed.

The *Exploration Case Studies* were followed in 1989 by NASA's "90-Day" Study,<sup>4</sup> which focussed primarily on the establishment of a permanent lunar base and "all-up" exploration missions to Mars. "All-up" refers to an operational mode in which all of the payload and propellant required for the entire Mars mission is carried on a single vehicle. The expendable chemical / aerobrake option used direct capsule reentry at Earth for crew recovery and had an initial mass in low Earth orbit (IMLEO) of ~831 t. The chemical TMI stage utilized LOX/LH<sub>2</sub> propulsion, and two large diameter (~ 30 m) aerobrakes, constructed in low Earth orbit, were used to capture the piloted lander / ascent vehicle and LOX / LH<sub>2</sub> trans-Earth injection (TEI) stage into Mars orbit. The "all NTR" option<sup>5</sup> used a single 75 klbf engine for all primary propulsion maneuvers, including Earth orbit capture (EOC), and had an IMLEO of ~668 t.

In May 1991, the *Synthesis Group* issued its report<sup>6</sup> entitled "America at the Threshold: America's

Space Exploration Initiative." In it different architectural approaches and technical strategies were outlined and fourteen key technologies necessary for safe and cost effective exploration of the Moon and Mars were identified. The top two technologies listed were a heavy lift launch vehicle and NTR propulsion. The Synthesis report stated that for Mars transit "*the nuclear thermal rocket is the preferred propulsion system allowing significantly reduced mass to low Earth orbit, shorter transit times and greater operational flexibility.*"<sup>6</sup> The use of aerobraking for Mars orbit capture (MOC) was rejected by the Synthesis Group in favor of capture using NTR propulsion because of a variety of mission-, spacecraft design-, and safety-related issues associated with aerobraking.<sup>6</sup>

In FY93, an intercenter NASA Mars Study Team was organized by the Exploration Project Office (ExPO) at the Johnson Space Center (JSC) and tasked with assessing the requirements for a piloted mission to Mars as early as 2010. A split / sprint mission with predeployed cargo was baselined and NTR propulsion was selected for all primary propulsion maneuvers in keeping with the Synthesis Group recommendations. "Fast conjunction-class" trajectories<sup>7,8</sup> were also featured to maximize the exploration time at Mars while reducing the total "in-space" transit time to approximately one year.

The reference Mars architecture was later changed by ExPO to incorporate a common, "dual use" aerobrake / descent shell and "in-situ" resource utilization (ISRU) in an effort to achieve a single launch cargo and piloted mission capability using a 240 t-class heavy lift launch vehicle (HLLV). Common habitat modules were also assumed for the piloted lander, surface hab and ERV. Using LH<sub>2</sub> brought from Earth, an ISRU plant would convert Martian carbon dioxide into liquid oxygen / methane (LOX/CH<sub>4</sub>) propellant to fuel a "dry" ascent stage carried to the Mars surface on the cargo lander mission<sup>9</sup>. A second cargo lander provided an additional habitat module, science equipment and consumables needed to support the crew during the long (~500 day) Mars surface exploration phase. A separate ERV, placed in Mars orbit, returned the crew and "dual use" ascent stage crew capsule to Earth where it provided a direct Earth entry capability. LOX/CH<sub>4</sub> propulsion was used on both the descent and TEI stages to maximize hardware commonality, and

NTR propulsion was used only for the TMI stage. Additional details on the FY93 reference Mars architecture are provided elsewhere.<sup>10,11</sup>

A common TMI stage powered by three to four 15 klbf NTR engines was developed for both the cargo and piloted missions<sup>10</sup> (see Figure 1). The TMI stage was sized by the 2009 piloted mission and its more energetically demanding 180-day trajectory and then used in the minimum energy cargo missions to maximize payload delivery to Mars. After a "2-perigee burn" Earth departure, the spent TMI stage was jettisoned and targeted for long-duration disposal into heliocentric space. In addition to the reference Mars architecture, GRC developed "all NTR" mission options (to capitalize on the NTR's higher performance) and modular vehicle designs using "standardized" engine and stage components.<sup>10</sup> The "modular approach" provided a number of attractive features which included enhanced mission flexibility and safety, simplified vehicle design and assembly, and reduced development / procurement costs through standardization of the "fewest number" of components. Vehicle designs compatible with a 120 t-class HLLV were also developed

and utilized a dual launch, Earth orbit rendezvous and dock (EOR&D) scenario for vehicle assembly. Particularly noteworthy, was the introduction and integration of "bimodal" NTR engines and active LH<sub>2</sub> refrigeration systems into the basic design of the ERV<sup>10</sup> (see Figure 2). The elimination of boiloff over the ~4.1 year mission duration of the ERV led to dramatic reductions in IMLEO, total engine burn time and LH<sub>2</sub> tank size.

In FY97, NASA's intercenter Mars Human Exploration Study Team was reconvened to reevaluate, refine and update the FY93 DRM. Key mission changes<sup>12</sup> included the use of an ~80 t-class HLLV called "Magnum" and adoption of a dual launch EOR&D vehicle assembly scenario. Payload manifests, including crew accommodations and consumables, were critically examined on each cargo and piloted mission to save mass and eliminate duplications. Mass reductions in large structures, like propellant tanks and habitat modules, were achieved through the use of advanced composites. A lightweight, inflatable hab module design developed by JSC was also examined. The expendable NTR TMI stage and "new" bimodal

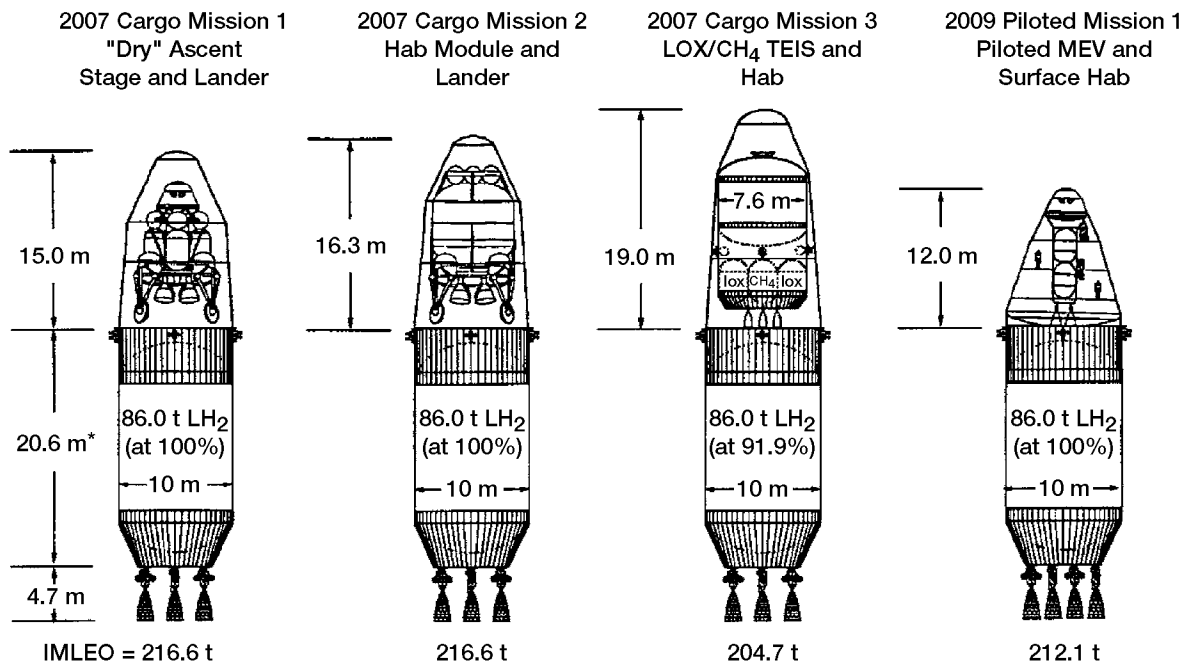

\*Expendable TMI Stage LH<sub>2</sub> Tank (at 18.2 m length) sized by 2009 Mars Piloted Mission.

Figure 1.—Reference Mars Cargo and Piloted Vehicles Using Common "NTR-Powered" TMI Stage.

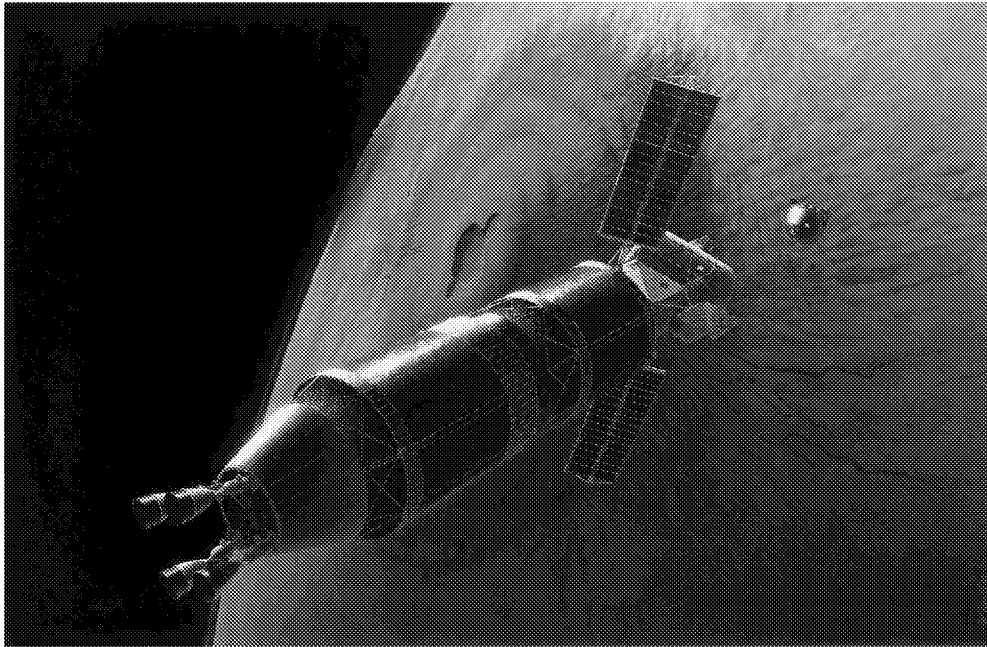

Figure 2.—Artist's Illustration of ERV with 50 kWe "Bimodal" NTR System and Active LH<sub>2</sub> Refrigeration. A 5 kWe Solar Array is Shown on the ERV for Scale.

NTR vehicle concepts developed during this study period were sized to fit within the mass and payload volume limits of the Magnum HLLV. To circumvent volume limitations, "LOX-augmented" NTR (LANTR) engines were also examined to increase "bulk" propellant density and maximize vehicle performance while staying within the mass limitations of a two Magnum scenario.

This paper describes the NTR vehicle and mission analysis results performed by the Glenn Research Center over the last ~18 months in support of NASA's intercenter Mars study effort. The paper first describes the operating principles and characteristics of the small, 15 klbf solid core NTR engines baselined in the study. This is followed by a discussion of the operational characteristics and benefits of the "bimodal" NTR and LANTR engine concepts. Next, key features of the Mars DRM are reviewed and a summary of mission and transportation system ground rules and assumptions are provided. Representative vehicle concepts and their operational characteristics are then presented for an expendable NTR TMI stage, several bimodal NTR vehicle options, and a LANTR vehicle configuration

capable of adding Phobos rendezvous and landing options to the current DRM. The paper concludes with a summary of our findings and a brief discussion of the evolvability of bimodal LANTR vehicles to support a fully reusable, Mars mission architecture and future human expansion.

#### NUCLEAR THERMAL ROCKET PROPULSION

The "solid core" NTR represents the next major evolutionary step in propulsion technology and is key to providing "*low cost access through space*" for future human exploration missions to the Moon, Near Earth Asteroids and Mars. The NTR is not a new technology. Its feasibility was convincingly demonstrated in the United States during the Rover / NERVA (Nuclear Engine for Rocket Vehicle Application) nuclear rocket programs.<sup>13</sup> From 1955 until the program was stopped in 1973, a total of twenty rocket reactors were designed, built and tested. These integrated reactor / engine tests, using LH<sub>2</sub> as both reactor coolant and propellant, demonstrated a wide range of engine sizes (from ~50 to 250 klbf), high temperature graphite fuel providing substantial hydrogen exhaust temperatures (~2350-2550 K),



sustained engine operation (over 60 minutes for a single burn) and restart capability (28 startups and shutdowns on the NRX-XE engine). The Rover / NERVA program costs were estimated at ~\$1.4 billion (an ~\$10 billion investment today).

Approximately four years after the start of the NERVA program, a nuclear rocket program was initiated in the former Soviet Union known today as the Commonwealth of Independent States (CIS).<sup>14</sup> Extensive nuclear and non-nuclear subsystem tests were conducted, including fuel element and reactor tests at the Semipalatinsk facility in Kazakhstan.<sup>15</sup> Although no integrated engine system tests were conducted, a high temperature ternary carbide fuel element was developed capable of producing hydrogen exhaust temperatures in excess of 3000 K—about 500 K higher than the best NERVA fuels.

#### NTR Operating Principles

Conceptually, the NTR engine is relatively simple (see Figure 3). High pressure propellant flowing from pumps cools the nozzle, reactor pressure vessel, neutron reflector, control drums, core support structure and internal radiation shield, and in the process picks up heat to drive the turbines. The hydrogen exhaust is then routed through coolant channels in the reactor core's fuel elements where it absorbs the energy released by fissioning uranium atoms, is

superheated (to 2700-3100 K), and then expanded out a supersonic nozzle for thrust. Controlling the NTR engine during its operational phases (startup, full thrust, and shutdown) is accomplished by matching the turbopump-supplied hydrogen flow to the reactor power level. Control drums, located in the surrounding reflector region, regulate the number of fission-released neutrons that are reflected back into the core and hence the reactor power level. An internal neutron and gamma radiation shield, containing interior coolant passages, is also placed between the reactor core and sensitive engine components to prevent excessive radiation heating and material damage.

#### Ternary Carbide Fuel NTR Engine Design

What's new about NTR propulsion today that warrants renewed investment in this technology? The answer lies in a reduced size, higher performance engine that can be ground tested at full power in a "contained facility" meeting current environmental regulations. Design studies,<sup>16,17</sup> funded by NASA's Nuclear Propulsion Office in 1992-1993 and conducted by a US / CIS industry team of Aerojet, Energopool and Babcock and Wilcox (B&W), produced a small advanced NTR engine concept with impressive parameters: thrust ~15 klbf, Isp ~940-960 s, engine thrust-to-weight ~3.1, and "full power" engine fuel lifetime of ~4.5 hours. The CIS engine design (shown in

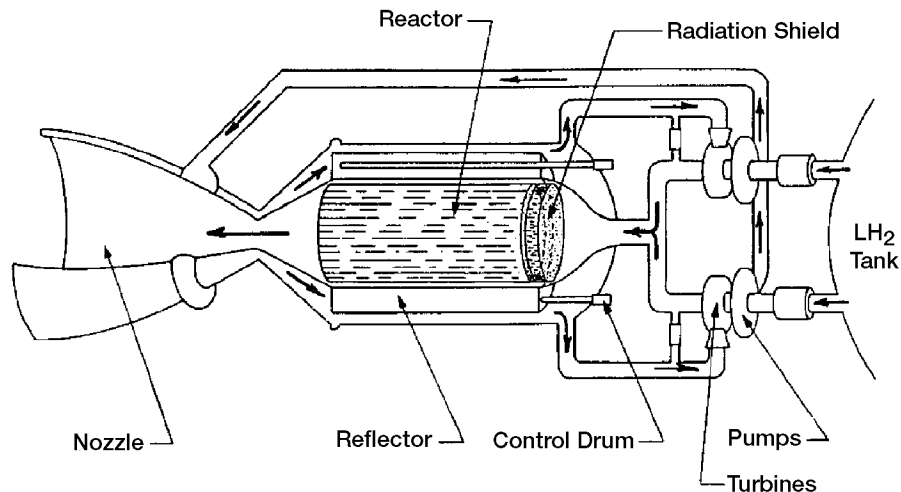

Figure 3.—Schematic of "Solid Core" NTR Using Dual Turbopump Expander Cycle.

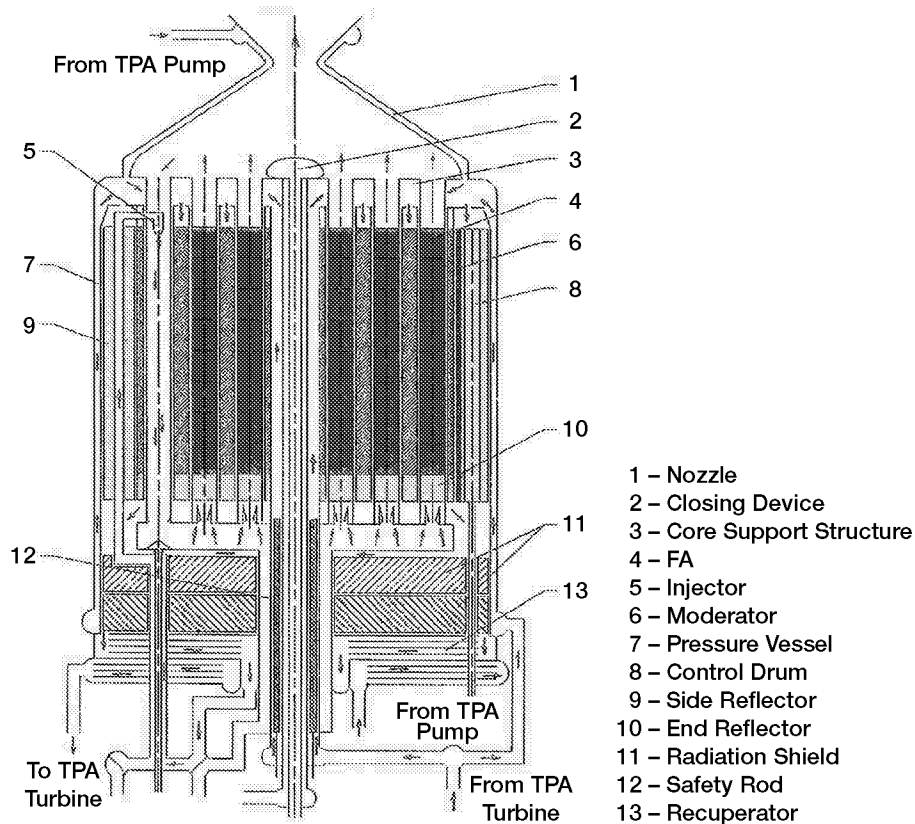

Figure 4.—Component Layout / Flow Schematic of CIS Engine.

Figure 4) utilizes a heterogeneous reactor core design with hydrogen-cooled zirconium hydride (ZrH) moderator and ternary carbide fuel materials. The ZrH moderator is located between reactor fuel assemblies and is very efficient in minimizing the inventory of fissile material in the reactor core. The CIS fuel assembly is an axial flow design and contains a series of stacked 45 mm diameter bundles of thin (~1 mm) “twisted ribbon” fuel elements approximately 2 mm in width by 100 mm in length. The “fueled length” and power output from each assembly is determined by specifying the engine thrust level and hydrogen exhaust temperature (or desired Isp). For a 15 klbf engine, 36 fuel assemblies (with 6 fuel bundles each) are used to generate the required 335 MWt of reactor power at the same Isp.

The ternary or “tricarbide” fuel material in each “twisted ribbon” element is composed of a solid solution of uranium, zirconium and niobium carbides having a maximum operating temperature expected to be about 3200 K. The fuel composition along the fuel assembly length is

tailored to provide increased power generation where the propellant temperature is low, and reduced power output near the bottom of the fuel assembly where the propellant is nearing its exhaust temperature design limit. In this current study, the CIS engine total power output has been fixed at 335 MWt and the hydrogen exhaust temperature allowed to vary from 2900 to 3075 K to provide increased Isp operation (from ~940 to 955 s) when needed. During reactor tests, hydrogen exhaust temperatures of 3100 K for over one hour and 2000 K for 2000 hours were demonstrated in the CIS.<sup>14</sup>

#### CIS Engine Power Cycle / Design Characteristics

The CIS engine design utilizes a dual turbopump, “recuperated” topping cycle.<sup>16,17</sup> Hydrogen flowing from each pump is split (see Figure 5), with ~84% of the flow going to a combination recuperator / gamma radiation shield and the remaining 16% used to cool the nozzle. The recuperator / shield, located at the top of the engine, provides all of the necessary turbine drive

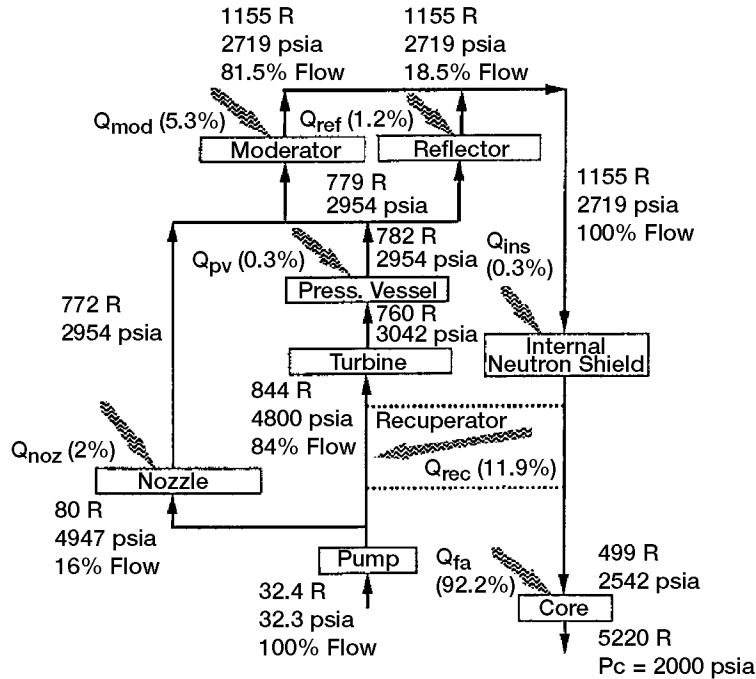

Figure 5.—Flow Schematic of Recuperated Topping Cycle for the CIS Engine.

power. The turbine exhaust cools the reactor pressure vessel and is then merged with the nozzle coolant to cool the moderator and reflector regions of the engine. The coolant then passes through borated ZrH and lithium hydride (LiH) neutron shields located within the pressure vessel between the reactor core and the recuperator/gamma shield (see Figures 4 and 5), before returning to the recuperator where it heats the pump discharge flow. Exiting the recuperator, the cooled hydrogen is then routed to the core fuel assemblies where it is heated to the required design temperatures. The 15 klbf CIS engine design has a chamber pressure of 2000 psia, a nozzle area ratio of 300 to 1, and a 110% bell length nozzle resulting in  $I_{sp}$  values of ~940 to 955 s for hydrogen exhaust temperatures in the range of 2900-3075 K. The approximate engine length and nozzle exit diameter for the 15 klbf CIS engine is ~4.3 m and ~1.0 m, respectively. A summary of key design features of the CIS engine is found in Table 1.

#### The “Bimodal” NTR—A Fully Integrated System

The bimodal NTR engine and vehicle concept was examined in detail during this study period to more fully exploit the performance potential of the NTR and enhance stage capabilities.

Besides its impressive propulsion characteristics, the solid core NTR represents a “rich source of energy” because it contains substantially more uranium-235 fuel in its reactor core than it consumes during its primary propulsion maneuvers. By reconfiguring the NTR engine for “bimodal” operation (Figure 6), abundant electrical power can also be generated to support spacecraft environmental systems, high data rate communications, and enhanced stage operations such as an active refrigeration / reliquification system for long term, “zero-boiloff” LH<sub>2</sub> storage. A bimodal NTR-powered spacecraft would be very similar to today’s nuclear-powered submarine which uses high-pressure steam provided to a turbine engine to drive the submarine’s propeller. Steam from the reactor also generates all of the submarine’s electricity.

Besides providing a continuous source of reactor thermal energy, bimodal operation is also beneficial because it: 1) reduces thermal stress on the reactor (it’s pre-heated); 2) minimizes large thermal cycling (no prolonged, deep “cold soak” of the engine); 3) allows rapid reactor restart (in case of emergency); 4) minimizes “decay heat removal” propellant penalty (by rejecting low power, “after-heat” through the power system’s space radiator); and 5) provides a source of

Table 1. Key Design Features of CIS / NTR Engines

Reactor Power	335
Engine Thrust (klbf)	(15 - 14.76)
Hydrogen Exhaust Temperature, K	2,900 - 3,075
Propellant Flow Rate, kg/s	7.24 - 7.01
Specific Impulse, s	940 - 955
Fuel Composition	(U,Nb,Zr)C
Fuel Form ("Twisted Ribbon"), mm	Approximate 100 x 1.6 x 1.0
Fuel Element Power Density (ave), MW/L	30
Core Power Density, MW/L	5.0
Fuel Volume, liters	11.5
Number of Assemblies (Elements)	36
Number of Safety Rods	13
Vessel Diameter, m	0.65
Reactor Fueled Length, cm	55
Reactor Mass (with internal shielding and recuperator), kg	2224
Engine Thrust-to-Weight Ratio	3.06
Total Engine Length, m	4.3
Nozzle Exit Diameter, m	1.0

heated, gaseous hydrogen (GH<sub>2</sub>) for propellant tank pressurization, and possible high Isp attitude control and orbital maneuvering systems.

During the power generation phase, the bimodal engine's reactor core operates in essentially an "idle mode" with a thermal power output of ~110 kilowatts. The energy generated within the reactor fuel assemblies would be removed using a variety of "closed loop" concept options (such as core support tie tubes, integrated energy extraction ducts within the individual fuel assemblies, or a throat closure plug) and then routed to a turboalternator-compressor Brayton power conversion unit using a helium-xenon (He-Xe), hydrogen-nitrogen (H<sub>2</sub>-N<sub>2</sub>), or other working fluid combination (see in Figure 6). A pumped-loop radiator system is used to reject system waste heat and is also available to help remove low level decay heat power following high thrust engine operation.

Several options for closed Brayton cycle (CBC) power generation are being considered for the

CIS engine design. Although the current CIS/CBC system is designed to radiate small amounts of thermal power at lower temperature (~1300 K) during the electric power generation phase, the same system can reject several megawatts of decay heat by operating the radiators at higher temperatures since heat transfer to space depends on the radiator surface temperature raised to the fourth power. Molybdenum alloy turbine wheels and niobium alloy static structures can withstand 1400 to 1500 K GH<sub>2</sub> inlet temperatures because the materials are compatible with GH<sub>2</sub> and have high strength-to-density ratios at these temperatures.<sup>16,17</sup> Within an hour or two after thrust generation, reactor power decays significantly and the CIS / CBC temperatures drop. For decay heat removal or higher power mode operation, coolant is routed through the fuel assemblies (FA) after the CIS Brayton cycle loop is closed by inserting a nozzle "throat plug" located at the aft end of a central drive shaft (see Figure 7). This action opens an annular duct which carries the coolant / working fluid to the CBC turbine inlet.<sup>16,17</sup> In order to prevent excessive

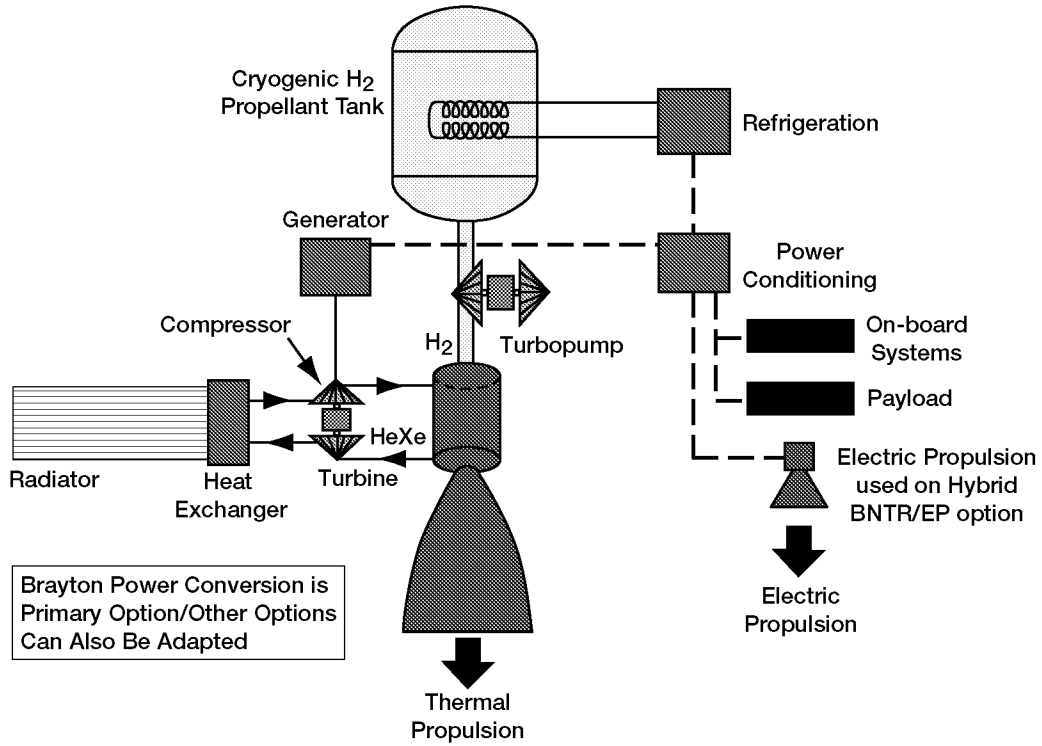

Figure 6.—Key Components of "Bimodal" NTR Stage — "A Fully Integrated System."

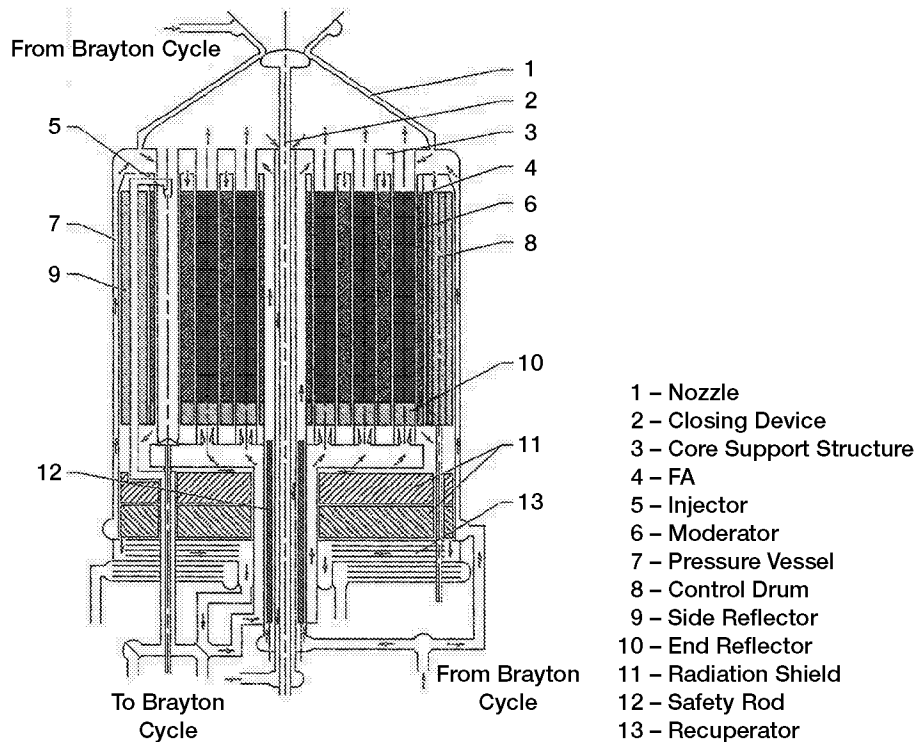

Figure 7.—Design Features of "Bimodal" CIS Engine Concept.

loss of coolant past the throat plug during many months of low electrical power generation, the  $\text{GH}_2$  coolant / working fluid is rerouted to passages through the FA walls before entering the Brayton rotating unit. During this period, the throat plug remains closed as a reliability enhancement feature, inhibiting possible coolant leakage from the system through any cracks that may develop in the FA wall.

#### The "LOX-Augmented" NTR (LANTR) Concept

An innovative "trimodal" NTR concept,<sup>18,19</sup> known as LANTR, is presently under study by NASA GRC which combines conventional  $\text{LH}_2$ -cooled NTR, Brayton cycle power generation and supersonic combustion ramjet (scramjet) technologies. During LANTR operation, oxygen is injected into the large divergent section of the NTR nozzle which functions as an "afterburner" (see Figure 8). Here, it burns spontaneously with the reactor-heated hydrogen emerging from the LANTR's sonic throat adding both mass and chemical energy to the rocket exhaust—essentially "scramjet propulsion in reverse."

The trimodal LANTR engine, illustrated in Figure 9, can operate as a conventional  $\text{LH}_2$ -cooled NTR, a bipropellant  $\text{LOX}/\text{LH}_2$  engine and a power reactor. Its principal components include a reactor and nozzle to heat and expand propellant, hydrogen and oxygen tankage and feed systems (using autogenous gas bleed for tank pressurization), and a closed Brayton cycle system for electric power generation and deep throttling. The CBC can also be used for engine "cooldown" assist as discussed above. The hydrogen feed system is powered by engine waste heat using the CIS recuperated topping cycle which enables the engine to run at a nozzle inlet pressure of 2000 psia. This and the fact that the recuperator also doubles as the reactor's cooled gamma radiation shield helps reduce engine size and mass. The LANTR engine generates electricity by bleeding reactor-heated  $\text{GH}_2$  or other working fluid through the Brayton cycle turbine, which drives an electric motor / generator and compressor. An "on-off" valve or throat plug is used to shut the nozzle throat during CBC operation and prevent leakage of the working fluid to space, and opened to the hot hydrogen exhaust during thrust mode

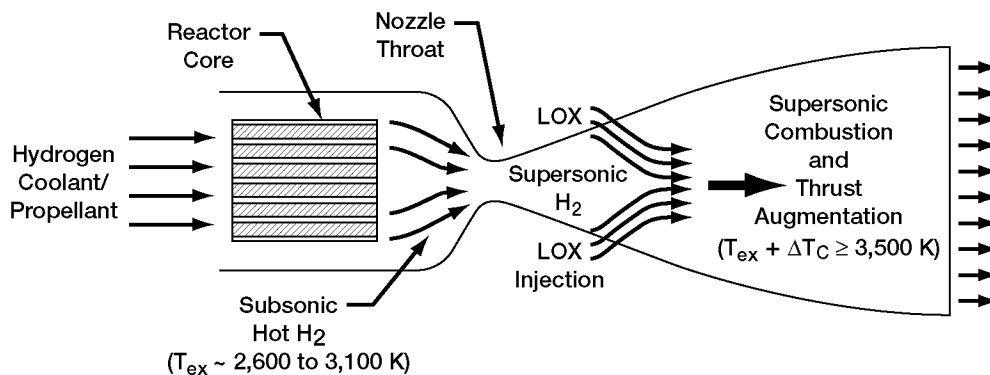

Life (hrs)	$I_{sp}$ (sec)			Tankage Fraction (%)	$T/W_{eng}$ Ratio
	5	10	35		
$T_{ex}$ (°K)	2,900	2,800	2,600		
O/H MR = 0.0	941	925	891	14.0	3.0*
1.0	772	762	741	7.4	4.8
3.0	647	642	631	4.1	8.2
5.0	576	573	566	3.0	11.0
7.0	514	512	508	2.5	13.1

\*For 15 klbf LANTR with chamber pressure = 2,000 psia and  $\epsilon = 500$  to 1

Figure 8.—Schematic/Characteristics of "LOX-Augmented" NTR.

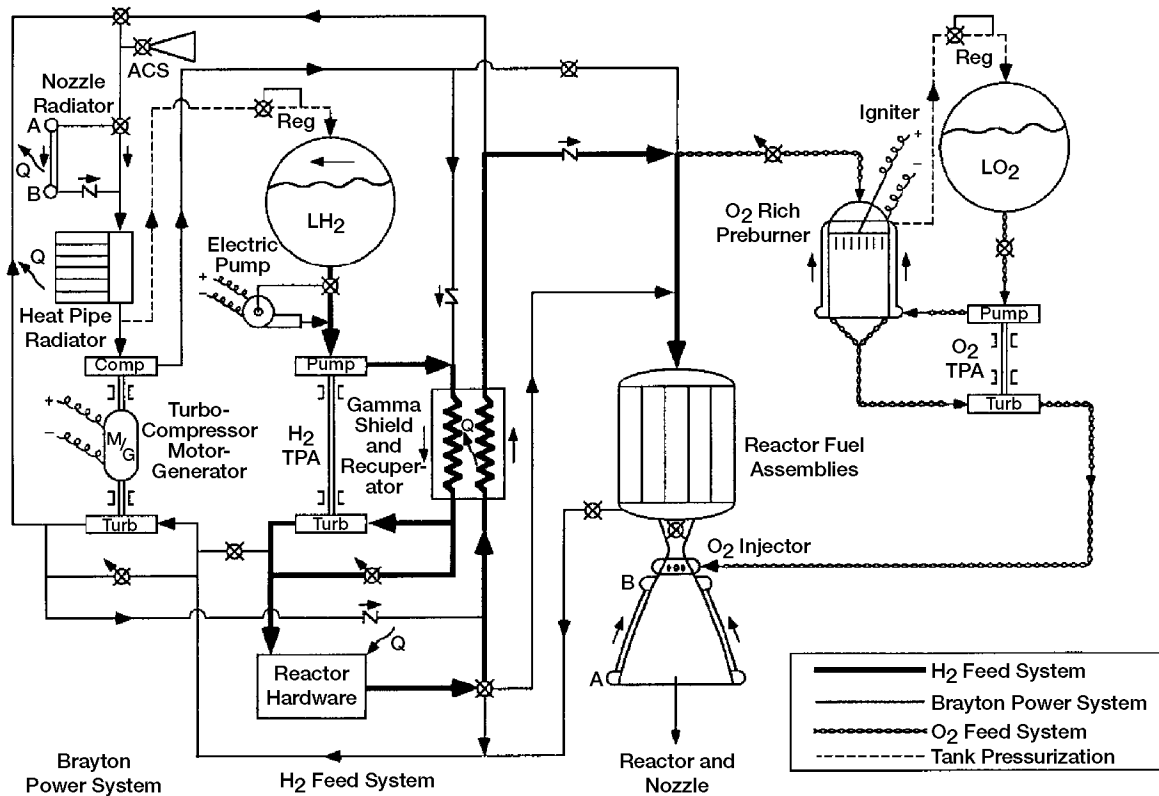

Figure 9.—Flow Schematic of "Bimodal" LANTR Engine.

operation. Waste heat can be rejected to space using a combination of nozzle and heat pipe radiator (as shown in Figure 9), or a dedicated radiator system as assumed in this study.

During bipropellant operation the oxygen feed system uses a topping cycle powered by an oxidizer-rich preburner. Downstream nozzle injection isolates the reactor core from oxygen damage provided the throat retains choked flow. This condition is satisfied by using a "cascade" scramjet injector concept developed by Aerojet which controls oxygen addition and heat release profiles (via staged injection) to keep the flow supersonic.<sup>18</sup> It also increases penetration, mixing and combustion of the oxygen injectant in the supersonic hydrogen flow while minimizing shock losses and formation of high heat flux regions (hot spots), thereby maximizing engine performance and life. The high reactor outlet pressure of the LANTR (~2000 psia) also enables high area ratio nozzles ( $\epsilon = 500$  to 1), important for combustion efficiency, at reasonable size and mass.

The LANTR concept has the potential to be an extremely versatile propulsion system. By varying the engine's oxygen-to-hydrogen (O/H) mixture ratio (MR), LANTR can operate over a wide range of thrust and Isp values (Figure 8) while the reactor core produces a relatively constant power output. For example, as the MR varies from 0 to 7, the engine thrust-to-weight ratio for a 15 klbf NTR increases by ~440%—from 3 to 13—while the Isp decreases by only ~45%—from 940 to 515 seconds. This thrust augmentation feature means that "big engine" performance can be obtained using smaller, more affordable, LH<sub>2</sub>-cooled NTR engines that are easier to develop and test in "contained" ground facilities. The engines can then be operated in space in the augmented high thrust mode to shorten burn times (thereby extending engine life) and reduce gravity losses (thereby eliminating the need for and concern over multiple, "perigee burn" Earth departure maneuvers). Reactor preheating of hydrogen before oxygen injection and combustion also results in higher Isp values than found in LOX / LH<sub>2</sub>

chemical engines operating at the same mixture ratio (~100 s at MR = 6). Lastly, the ability to substitute high-density LOX for low-density LH<sub>2</sub> provides the vehicle designer substantial flexibility in configuring spacecraft which can accommodate a wide variety of mission needs, as well as, “volume-constrained” launch vehicle designs.

**DESIGN REFERENCE MISSION DESCRIPTION**

The Mars Exploration Study Team is presently assessing a variety of mission architectures and transportation system options for conducting a human mission to Mars in the 2014 timeframe centered around a split cargo/piloted sprint mission approach. The mission profile shown in Figure 10 assumes the use of aerobraking at Mars and “in-situ” production of ascent propellants to reduce mission mass and transportation system requirements from Earth. The piloted mission is preceded by two cargo missions which depart Earth in

November 2011 and arrive at Mars ~297 days later. Each cargo and piloted vehicle requires two ~80 t “Magnum” HLLVs (one for the aerobraked payload and the other for the NTR TMI stage) and utilizes an EOR&D vehicle assembly sequence. A “common” aerobrake / descent shell is assumed for either capture into Mars orbit or direct descent to the Mars surface. The expendable NTR TMI stage (not shown in Figure 10) is jettisoned after an appropriate “cooldown” period and subsequently disposed of along its heliocentric trajectory.

The cargo lander mission carries a surface payload consisting of a “dry” Mars ascent stage and crew cab combination, nuclear power systems, LH<sub>2</sub> “feedstock” and ISRU plant, an inflatable laboratory module, rovers and science equipment (The complete mass manifest for the cargo lander is found in the Appendix in Table A-2). The payload element delivered to Mars orbit consists of the crew return habitat module, “fueled” TEI stage

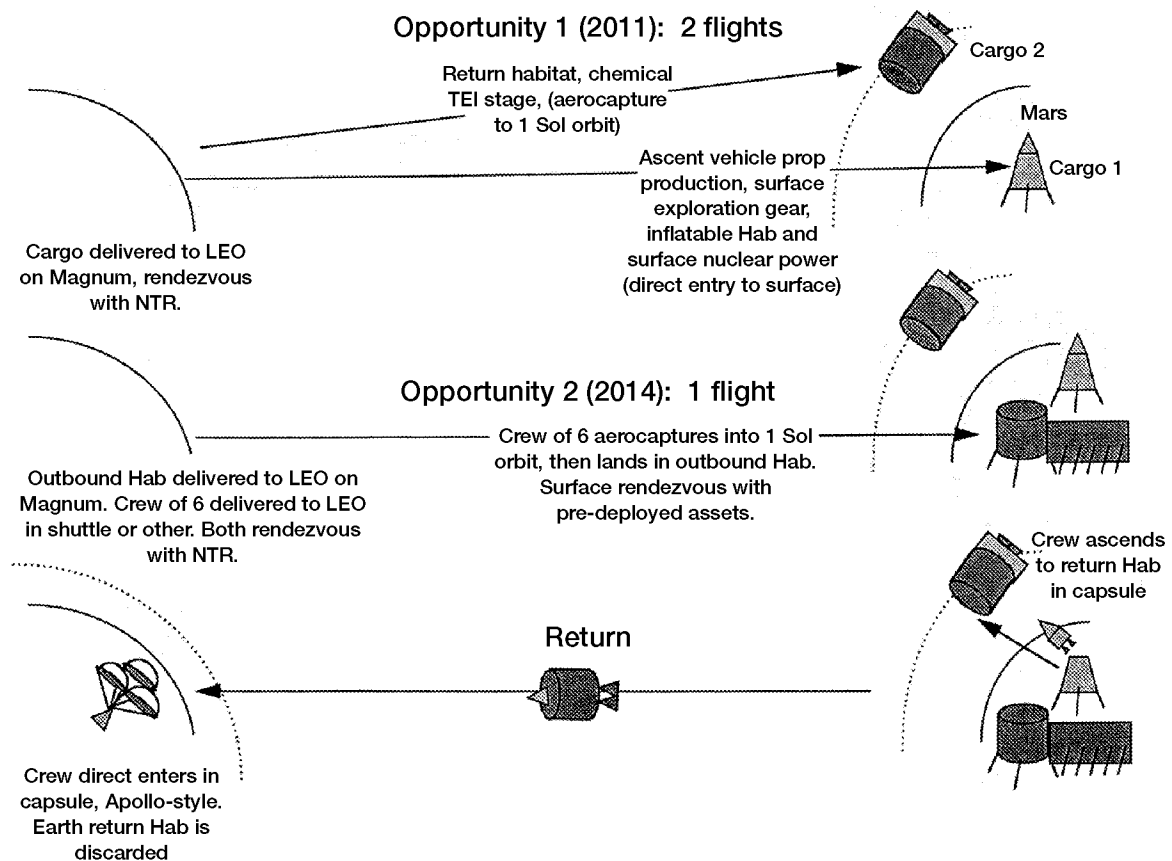

Figure 10.—Candidate Mission Profile for Mars Design Reference Mission.



and integrated aerobrake structure. After the operational functions of the ERV and cargo lander are verified, and the ascent stage is fully fueled with LOX/CH<sub>4</sub> propellant, the piloted vehicle leaves Earth in January 2014 (mass manifests for the ERV and piloted lander are found in the Appendix Tables A-1 and A-3, respectively). It arrives at Mars ~180 days later using a “fast conjunction-class” trajectory,<sup>7,8</sup> which maximizes the exploration time at Mars while reducing the total in-space transit time to approximately a year. After a 554-day stay at Mars, the crew returns in the ascent portion of the cargo lander to a waiting ERV to begin preparations for the 6 month journey back to Earth. The ascent stage crew cab doubles as an Earth crew return vehicle (ECRV) and is retained by the ERV for the trip home. Nearing Earth, the crew separates from the ERV and reenters the atmosphere in the ECRV while the ERV flies by Earth and continues on into deep space. The total duration of the piloted and ERV missions are 914 days and 1701 days, respectively.

#### MARS MISSION / TRANSPORTATION SYSTEM GROUND RULES AND ASSUMPTIONS

The ground rules and assumptions for the reference mission architecture and NTR-based transportation system examined in this study are summarized in Tables 2 and 3, respectively. In Table 4, the  $\Delta V$  budgets are listed for both the aerobrake (AB) and “propulsive capture” (PC) versions of the DRM. Table 5 provides additional  $\Delta V$  requirements for the “all NTR” mission options which take into account disposal of spent cargo and piloted NTR stages (either along their interplanetary trajectories or into a stable heliocentric orbit between Earth and Mars at 1.19 astronomical units [A.U.]) at mission end. While Table 2 highlights key features and characteristics of the DRM (e.g., scaling of the “triconic” aerobrake/descent shell mass), Table 3 provides details on NTR and LANTR systems, auxiliary RCS propulsion, cryogenic tankage, propellant thermal protection and boiloff rates, refrigeration system mass and power requirements, and contingency factors used in this study. Although primary propulsion maneuvers are performed using either the NTR or LANTR engines, the spacecraft also executes midcourse and secondary maneuvers using a storable, bipropellant RCS system.

The use of composite materials is assumed for all Mars transportation stage masses (e.g., descent /

ascent stages, NTR LH<sub>2</sub> propellant tanks and primary structures, etc.) for weight reduction. The wall thicknesses for the LH<sub>2</sub> tanks were calculated based on a 35 psi internal pressure and included hydrostatic loads using a “5g” loading and a safety factor of 1.5. A 3 percent ullage factor was also baselined in this study. For the LOX tanks on LANTR, a 50 psi internal pressure was assumed resulting in wall thicknesses of ~0.05 inches.

An 80 layer (~2.1 inch), multilayer insulation (MLI) system (at 38 layers per inch) is assumed for thermal protection<sup>20</sup> of the LH<sub>2</sub> and LOX cryogenic tanks. This insulation thickness exceeds the “ground hold” thermal protection requirements for “wet-launched” LH<sub>2</sub> tanks which need a minimum of ~1.5 inches of helium-purged insulation.<sup>21</sup> The installed density of the 80 layer MLI system is ~1.44 kg / m<sup>2</sup>, and the resulting LH<sub>2</sub> boiloff rate in LEO is ~3.11 x 10<sup>-2</sup> kg/m<sup>2</sup>/day (based on an estimated heat flux of ~0.161 W / m<sup>2</sup> at a LEO sink temperature of ~230 K). The corresponding boiloff rate for LOX is shown in Table 3. Finally, to account for micrometeoroid protection of propellant tanks (while in LEO, Mars orbit, and during transit to and from Mars), an ~0.50 mm thick sheet of aluminum (corresponding mass of ~1.35 kg / m<sup>2</sup>) is also included in the total tank weight estimates.

The NTR vehicle concepts developed in this study employ different thermal protection systems for LH<sub>2</sub> consistent with the vehicle’s mission application and expected lifetime. For the expendable NTR TMI stages, which have a “limited life” in LEO of ~32 days before departure, an ~2 inch “minimum mass” MLI system is used resulting in a LH<sub>2</sub> boiloff of ~0.46 t. The “all BNTR”-powered ERV mission has the most demanding requirements for thermal protection with a mission elapsed time between TMI and TEI of 1521 days (~4.2 years). For this mission application, an active system was developed consisting of a 2 inch MLI blanket and a turbo-Brayton refrigerator. Selection of the turbo-Brayton system was based on a NASA-funded study and survey<sup>22</sup> of various refrigeration systems which indicated its suitability for large LH<sub>2</sub> tanks requiring refrigeration capacities in the 10 to 100 watt cooling range. Table 3 shows the specific mass and input power assumptions used in estimating the inert weight and electrical power demands for the common, “refrigerated” BNTR core stage developed in this study.

Table 2. Mars Mission Study Ground Rules and Assumptions

- 
- Split Mission Scenario: (2 Cargo Missions in 2011,  
1 Piloted Mission in 2014)
  - Payload Elements Consist of Mars Cargo Lander, Earth Return Vehicle (ERV)  
and Piloted Lander with 6 Crew.
  - Dual Launch Earth Orbit Rendezvous and Dock Vehicle Assembly at 407 km  
using two 80 – 88 t “Magnum” HLLVs.
  - Magnum Payload Shroud Dimensions:  
7.6 m (I.D.) x ~ 28.0 m Length
  - Aerobraking and Propulsive Capture into 250 x 33,793 km (1 sol) Elliptical  
Mars Parking Orbit
  - Aerodescent Shell and Parachutes for Descent to Mars (descent  $\Delta V = 632$  m/s)
  - Aerobrake/Descent Shell Sizing:  $M_{AB}(t) = \sqrt{M_{PL} (a + bV_e)} + M_s$ ; where  
( $M_{PL}$  = payload mass in t,  $a = -0.55$ ,  $b = 0.19$ ,  $V_e$  = entry velocity in km/s and  
 $M_s$  = structural mass = 6 t)
  - Mars Descent Stage uses 4 – 15 klbf LOX/CH<sub>4</sub> Engines (Isp = 379 s, MR = 3.5,  
Stage Boiloff Rate: ~ 0.4 %/month)
  - “In-Situ” Production of LOX/CH<sub>4</sub> Ascent Propellant using Earth-Supplied LH<sub>2</sub>
  - Mars Ascent Stage  $\Delta V$  to 1 sol orbit: 5625 m/s
  - Mars Ascent Stage  $\Delta V$  to Phobos orbit: 5400 m/s
  - Mars Ascent Stage and Crew Capsule Rendezvous with ERV/Crew Capsule  
Retained/Doubles as Earth Crew Return Vehicle (ECRV)
  - Chemical Trans-Earth Injection (TEI) Stage uses 2 – 15 klbf LOX/CH<sub>4</sub> Engines  
(Stage Boiloff Rate: ~ 0.2%/month)
  - Direct Reentry of ECRV and Crew at Earth Arrival
  - Mission Abort Strategy:
    - Outbound: Abort to Mars Surface
    - At Mars: Abort to ERV, which carries contingency consumables.
-

**Table 3. Mars NTR / LANTR Transportation System Assumptions**

• NTR / LANTR Systems:	Thrust /Weight	=	15 klbf / 2224 kg (LH <sub>2</sub> NTR)
		=	15 klbf / 2630 kg (LANTR @ MR = 0.0)
	Fuel / Propellants	=	Ternary Carbide / Cryogenic LH <sub>2</sub> & LOX
	Isp	=	940 - 955 s (@ O/F MR = 0.0 / LH <sub>2</sub> only)
		=	831 s (@ O/F MR = 0.5)
	External Shield Mass	=	2.84 kg/MWt of reactor power
	Flight Reserve	=	1% on ΔV
	Residual	=	2% of total tank capacity
	Cooldown (effective)	=	3% of usable LH <sub>2</sub> propellant
• RCS System:	Propellant	=	N <sub>2</sub> O <sub>4</sub> / MMH
	Isp	=	320 s
	Tankage	=	5% of total RCS propellants
• Cryogenic Tankage/ Thermal Protection:	Material	=	Advanced Composite
	Diameter	=	7.4 m (LH <sub>2</sub> ) / 2.6 m (LOX)
	Geometry	=	cylindrical with √2/2 domes / spherical
	Insulation	=	2.1 inches (80 layers) MLI @ 1.44 kg/m <sup>2</sup>
	LH <sub>2</sub> /LOX Boiloff*	=	3.11 x 10 <sup>-2</sup> / 6.49 x 10 <sup>-2</sup> kg/m <sup>2</sup> /day
• LH <sub>2</sub> Refrigeration System:	Shield	=	1.35 kg/m <sup>2</sup> (~0.5 mm sheet of Aluminum)
	Specific Mass	=	4.57 kg/W refrig. @ 75 Watts
	Input Power	=	~0.11 - 0.20 kWe / W refrig.
	• Contingency	Engine, shields and stage dry mass	=

\* Based on estimated heat flux of ~ 0.1608 W/m<sup>2</sup> at LEO sink temperature of ~230 K

**Table 4. Mars Cargo and Piloted Mission ΔV Budgets (Ideal)**

Vehicle Mission Mode	Launch Date	Outbound Transit Time (days)	Inbound Transit Time (days)	Total Mission Time (days)	TMI ΔV (km/s)	MOC ΔV (km/s)	TEI/EOC ΔV (km/s)	Total Ideal ΔV (km/s)
Cargo	11/8/11 (AB @ Mars)	297	NA	297	3.580	AB	NA	3.580
	11/9/11 (PC @ Mars)	307	NA	307	3.581	0.925	NA	4.505
	12/4/13 (PC @ Mars)	294	NA	294	3.605	1.162	NA	4.767
	12/31/13 (AB @ Mars)	328	NA	328	3.572	AB	NA	3.572
	Piloted	1/4/14 (AB @ Mars)	180	180	914 (554 @ Mars)	3.672	AB	NA
2/2/14 (PC @ Mars)		180	180	885 (525 @ Mars)	4.214	2.251	NA	6.465
1/21/14 (PC @ Mars)		210	180	897 (507 @ Mars)	3.861	1.720	NA	5.581
1/18/14 (PC @ Mars)		220	180	900 (500 @ Mars)	3.823	1.629	NA	5.452
ERV		11/8/11 (AB @ Mars)	297	180	1702 (1225 @ Mars)	3.580	AB	1.079
Piloted	11/9/11 (PC @ Mars)	307	180	1701 (1214 @ Mars)	3.581	0.925	1.079	5.585
Inbound	11/9/11 (PC @ Mars)	307	180	1731 (1244 @ Mars)	3.581	0.925	1.419/1.365	7.290

Note:

ΔV based on 407 km circular orbit at Earth and 250 X 33793 km Mars parking orbit.

G-losses appropriate to "single or double perigee burn" Earth departure must be added to the TMI ΔV shown.

Apsidal/nodal alignment penalty of 500 m/s must be added to the TEI ΔV value shown.

Because of the inventory of radioactive fission products that will be generated in the BNTR engines during their service life, care must be taken to dispose of these vehicles in a responsible manner at mission end. Calculations by Stancati<sup>23,24</sup> using the Planetary Encounter Probability Analysis (PEPA) code have provided estimates of the  $\Delta V$  requirements and probabilities of NTR vehicle collisions with Earth for various disposal scenarios (shown in Table 5). In the Mars mission scenario depicted in Figure 10, the expendable NTR TMI stages are disposed of along their interplanetary path after payload separation. Table 5 shows that the probabilities for Earth reencounter over the course of a million years are ~13% and 11% for the cargo and piloted TMI stages, respectively. The increased probability for the cargo missions are due to their near-Hohmann trajectories. For the “all NTR” mission scenarios,

the BNTR stages used on cargo and piloted lander missions are removed from Mars orbit shortly after the ERV leaves for Earth. Although a stable parking orbit exists at ~1.19 A. U., the  $\Delta V$  penalty for disposal to this location is appreciable at ~2.52 km/s (see Table 5). A second disposal option adopted in this study is to leave the NTR vehicles on their flight paths to 1.19 A. U., but to eliminate the final capture and circularization burns. This option reduces the disposal  $\Delta V$  to ~0.33 km/s and though it allows for possible future encounters with Earth, the probabilities are very small (<<1%).

#### EXPENDABLE TRANS-MARS INJECTION STAGE

A “common” TMI stage design has been developed for both the Mars cargo and piloted missions which employs three ~15 klbf CIS / NTR engines, each weighing 2224 kg and operating

**Table 5. Mars Disposal  $\Delta V$  Requirements**

Mission	Disposal Initiated	Req'd Maneuvers	$\Delta V$ Disposal (km/s)	Earth Encounter Probability
• 2011 Cargo (AB @ Mars)	after TMI/ before MOC	none - TMI stage disposed along interplanetary path	0	13% in 10 <sup>6</sup> years
• 2011 Cargo (PC @ Mars)	from Mars orbit after cargo delivery	depart Mars orbit/ circularize @ 1.19AU	0.331 2.184 <hr/> 2.515	0
• 2011 Cargo (PC @ Mars)	from Mars orbit after cargo delivery	depart Mars orbit to 1.19AU / dispose along interplanetary path	0.331 0 <hr/> 0.331	0.02% in 10 <sup>6</sup> years
• 2014 Piloted (AB @ Mars)	after TMI/ before MOC	none - TMI stage disposed along interplanetary path	0	11% in 10 <sup>6</sup> years
• 2014 Piloted (PC @ Mars)	from Mars orbit after cargo delivery	depart Mars orbit/ circularize @ 1.19AU	0.331 2.184 <hr/> 2.515	0
• 2014 Piloted (PC @ Mars)	from Mars orbit after cargo delivery	depart Mars orbit to 1.19AU / dispose along interplanetary path	0.331 0 <hr/> 0.331	0.02% in 10 <sup>6</sup> years
• 2011 Earth Return Stage (PC @ Mars)	after Earth flyby & ECRV separation	Earth gravity assist/ circularize @ 1.19AU	0 2.951 <hr/> 2.951	0
• 2011 Earth Return Stage (PC @ Mars)	after Earth flyby & ECRV separation	Earth gravity assist/ disposal along interplanetary path	0	11% in 10 <sup>6</sup> years

with an Isp of ~940 s. For a fixed total reactor power output of ~335 MWt, the engines are capable of operating at higher Isp values (~955 s) by increasing fuel temperature (from 2900 K to ~3075 K) which results in a small decrease in thrust (down to ~14.76 klbf). The single tank stage is sized to accommodate both the 2007 ERV cargo mission with a  $C3 = 13.41 \text{ km}^2 / \text{s}^2$  and a payload of ~74 t, or the energetically demanding, fast transit 2009 piloted mission (with  $C3 = 20.06 \text{ km}^2 / \text{s}^2$ ).

The size, mass and key features of the common NTR TMI stage and its aerobraked payloads is illustrated in Figure 11 and a rendered three-dimensional (3-D) image of the stage and payload is provided in Figure 12. The TMI stage LH<sub>2</sub> tank is cylindrical with  $\sqrt{2}/2$  ellipsoidal domes. It has an inner diameter of 7.4 m, an ~20.6 m length, and a maximum propellant capacity of ~56 t assuming a 3% ullage factor. The main stage components include the LH<sub>2</sub> tank; thermal and micrometeoroid protection; a forward cylindrical adaptor section housing avionics and auxiliary power, RCS and docking systems; forward and aft skirts; thrust structure; propellant feed system; and NTR engines. Stage auxiliary power is provided by an oxygen/hydrogen fuel cell system which supplies 1.5 kWe for up to 32 days in LEO. Assuming a consumption rate of ~0.415 kg per kWe-hour, ~0.48 t of reactants (at an O / H ratio of 8 to 1) are required. The hydrogen reactant is drawn from the main propellant tank while the oxygen reactant is stored in several small spherical tanks in the forward section of the stage. The expendable TMI stage has a length of ~27.5 m as shown in Figure 11 and a total “dry mass” estimated to be ~22.2 t. For the piloted missions, an external disk shield is added to each engine to provide crew radiation protection. This added shielding increases the stage dry mass by ~3.2 t. A summary mass breakdown for the TMI stage is provided in Table 6.

To minimize LH<sub>2</sub> boiloff during the vehicle assembly phase, the cargo lander and ERV payloads are launched first, followed by the two TMI stages. Assuming 30 days between Magnum launches and ~2 days for vehicle checkout, the longest period any TMI stage is in LEO is ~32 days. After EOR&D and checkout, the ~51 m long cargo and piloted vehicles are ready to leave for Mars. A “2-perigee burn” Earth departure scenario is assumed which includes gravity losses and a 1% margin on total TMI  $\Delta V$ . The gravity losses for the cargo lander and ERV missions ( $C3 \sim 8.95 \text{ km}^2 / \text{s}^2$ ),

**Table 6. Mass Breakdown for “Common” NTR TMI Stage\***

Stage Element	Mass (t)
Structure	2.45
Propellant Tank (L <sub>t</sub> = 20.6 m x 7.4 m I.D.)	6.66
Thermal/Micrometeor Protection System	1.39
Avionics and Power	1.2
Reaction Control System (RCS)	0.42
NTR Assemblies	
• 15 klbf CIS NTRs (3)	6.67
• External Shields (3)	0 - 2.82
• Propellant Feed, TVC, etc.	0.56
Contingency (15%)	2.90 - 3.33
“Dry” TMI Stage	22.24 - 25.48
LH <sub>2</sub> Propellant (max. LH <sub>2</sub> cap. = 56.0 t)	52.0 - 52.61
RCS Propellant	0.77 - 0.88
Fuel Cell Reactants (O <sub>2</sub> )	0.43
“Wet” TMI Stage	75.44 - 79.40

\*2007 ERV mission sizes the TMI stage LH<sub>2</sub> tank.

and the piloted lander mission ( $C3 \sim 11.04 \text{ km}^2 / \text{s}^2$ ) are ~95, 110 and 101 m/s, respectively. Similarly, the corresponding total TMI engine burn times for the three missions are ~35, 39 and 36 minutes—well within previously demonstrated capabilities.

Table 7 summarizes the mission mass manifests for the first two cargo flights and the subsequent piloted mission. The cargo lander carries the crew ascent stage (shown in Figure 13) and utilizes a jettisonable aerobrake / descent shell. It has a total mass of ~66 t of which ~40.2 t is surface landed payload. The mass of the aerobrake is estimated to be ~9.9 t assuming a Mars entry velocity of ~5.65 km/s and a entry mass (not including the aerobrake) of ~56.1 t. Of the total 9.9 t, ~3.9 t is associated with the TPS system and the remaining 6.0 t with the 23 m long triconic aerobrake structure (see Table 2). Following orbit capture, subsequent deorbit and atmospheric reentry, the aerobrake shell is jettisoned, and parachutes are deployed to slow the spacecraft descent velocity to ~632 m/s. This final terminal velocity is removed by the descent stage which carries ~11 t of propellant and uses four RL 10-class engines modified to burn LOX/CH<sub>4</sub>. The “wet” TMI stage carries ~48 t of LH<sub>2</sub> propellant and has a total mass of ~71.1 t resulting in an IMLEO of ~137.1 t for the cargo lander mission.

The ERV mission utilizes an integrated aerobrake / hab module / TEI stage design with LOX / CH<sub>4</sub> engines, and has a total mass of ~74.1 t.

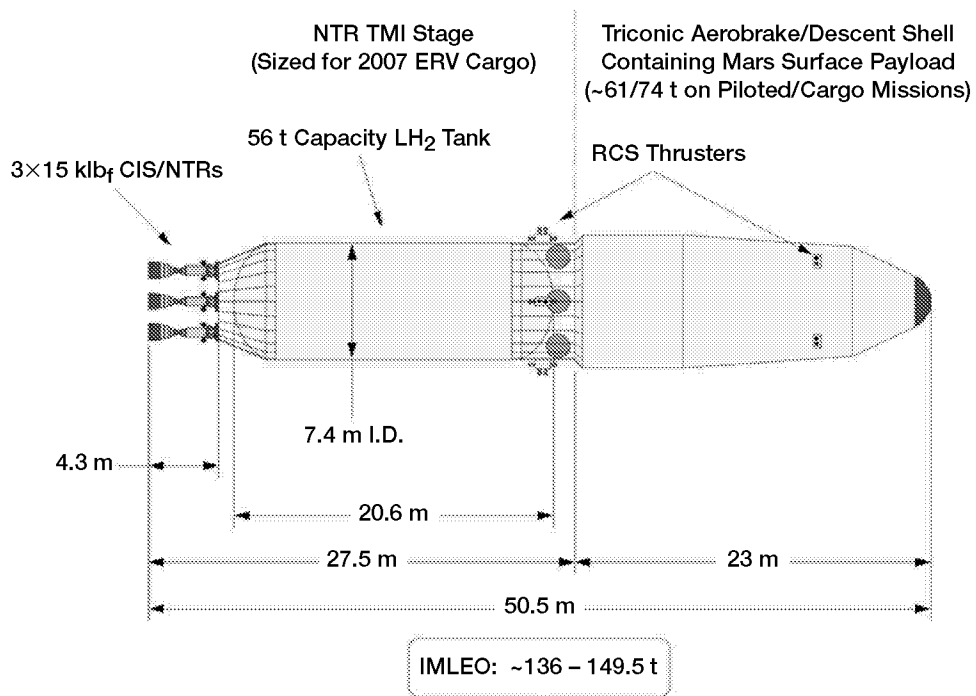

Figure 11.—Size, Mass and Key Features of "Common" TMI Stage and Aerobraked Payloads.



Figure 12.—3-D Image of Expendable TMI Stage and Aerobraked Payload.

**Table 7. DRM “Three Mission” IMLEO Summary  
 (“2 Perigee Burn” Earth Departure Scenario)  
 (IMLEO ≤ 160 t / 2-80 t “Magnum”/Shuttle C HLLVs)**

Stage/ Propulsion/ Isp	Element Masses (t)	2011 Cargo Lander Mission	2011 ERV Mission	2014 Piloted Lander Mission
TEI Stage LOX/CH4 Isp = 379 s (O/F = 3.5:1)	Return Habitat		29.10	
	TEI Stage		5.89	
	Propellant		28.90	
Ascent Stage LOX/CH4 Isp = 379 s (O/F = 3.5:1)	Crew (6) & Suits			1.44
	MAV Crew Cab/ ECRV	4.80		
	Ascent Stage	4.10		
	Propellant*	38.40		
Descent Stage LOX/CH4 Isp = 379 s (O/F = 3.5:1)	Habitat & Surface Payload	31.34		29.51
	Descent Stage	4.20		4.20
	Propellant**	10.98		11.38
MOC System	Aerobrake/Descent Shell ( $M_{AB} = \sqrt{M_{PL} (a + bV_a) + M_s}$ )*	9.92	10.18	13.58
	Parachutes	0.70		0.70
Total Payload Mass		66.04	74.07	60.81
Expendable TMI Stage LH <sub>2</sub> NTRs @ 940-955 s	F(klbf) per eng/Isp(s)	14.76/955	14.76/955	14.76/955
	CIS Engines (#)	7.67 (3)	7.67 (3)	7.67 (3)
	Radiation Shields (#)			3.24 (3)
	TMI Stage Tank & Structure	12.72	12.72	12.72
	Avionics & Aux. Power	1.37	1.37	1.37
RCS @ 320 s	Propulsion & Tankage	0.47	0.47	0.48
Propellants /Reactants	LH <sub>2</sub> Propellant***	47.67	52.01	48.20
	NTO/MMH Propellant	0.77	0.77	0.88
	Fuel Cell Reactants (O <sub>2</sub> )	0.43	0.43	0.43
Total “Wet”+B17 TMI Stage		71.10	75.44	74.99
Total IMLEO		137.14	149.51	135.80

\* Ascent propellant produced @ Mars ( $\Delta V = 5625$  m/s and Isp = 379 s)

\*\* Assumes use of parachutes with descent  $\Delta V = 632$  m/s

\*\*\* Contains boiloff, cooldown, and “tank trapped” residuals

+ ARC Triconic aerobrake mass estimation formula (Table 2)

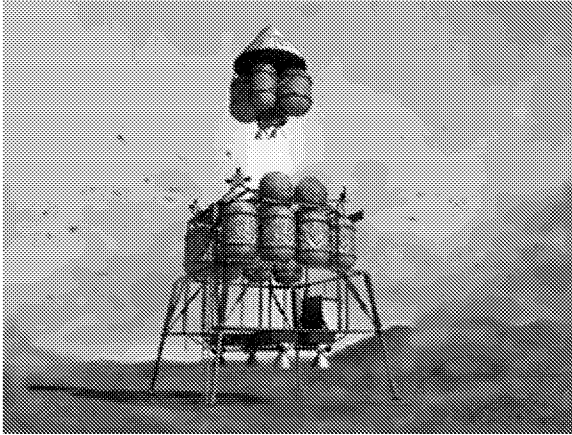

Figure 13.—Cargo Lander Showing Crew Ascent Stage Departure.

This heavier payload increases the LH<sub>2</sub> propellant loading to ~52 t and the total TMI stage mass to ~75.4 t resulting in an IMLEO of ~149.5 t. The piloted mission has an IMLEO of ~135.8 t consisting of a 75 t TMI stage and an “integrated” habitat / aerobrake lander configuration (shown in Figure 14) weighing ~61 t. Approximately 31 t of the piloted lander mass is surface payload which includes a crew of six. Because of its fast transit time (180 days) and higher entry velocity at Mars (~8.7 km/s), the piloted lander also requires an aerobrake which is ~3.5 t heavier than that used on the preceding cargo missions. To reduce aerobrake development costs and eliminate the need for “customized” designs on each mission, a “common” aerobrake configuration could be developed and used on all cargo and piloted

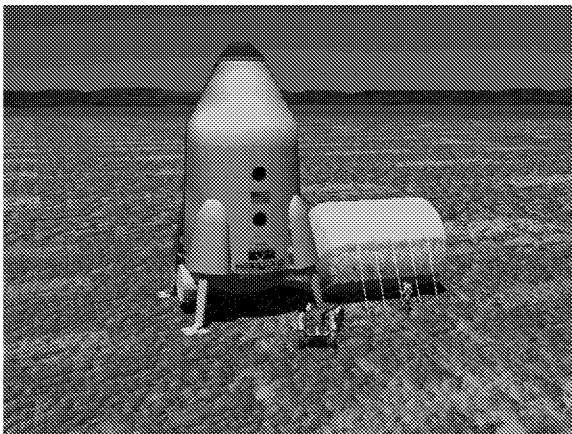

Figure 14.—Piloted Lander Concept with Inflatable Surface Habitat.

missions. The common design would be sized to accommodate the heaviest payloads and entry velocities anticipated over the ~15 year synodic cycle. The use of the heavier piloted aerobrake on the 2011 ERV mission would require enlarging the size and propellant capacity of the TMI stage LH<sub>2</sub> tank, further increasing the total mission IMLEO and Magnum lift requirements.

Although a “2-perigee burn” departure scenario has been baselined for the DRM, “single burn” departures can also be easily accommodated on the cargo and piloted lander missions since the TMI stage LH<sub>2</sub> tanks contain only ~85% of their maximum propellant capacity. Decreasing engine fuel temperature and Isp to 2900 K and 940 s, and using a single burn departure increases gravity losses, engine burn time, propellant loading and IMLEO to ~362 m/s, 38.2 min, 52.9 t and 142.3 t, respectively, for the cargo lander mission, and ~380 m/s, 38.7 min, 53.6 t and 141.2 t for the piloted mission.

Following the short TMI maneuver and an appropriate engine cooldown period, the aerobraked payload and “spent” NTR TMI stage separate with the Mars spacecraft continuing on its nominal mission. The storable bipropellant RCS system onboard the TMI stage is then used to perform the final midcourse correction and targeting maneuvers ( $\Delta V$  ~100 m/s) which place the TMI stage onto its final disposal trajectory. Because of the miniscule burnup of enriched uranium-235 during the Earth departure burn (~10 grams out of 33 kilograms in each NTR core), disposal of the TMI stage and its engines after a single use is a costly and inefficient use of this high performance stage. By reconfiguring the engines for both propulsion and power generation (“bimodal” operation), a multiple burn, “power-rich” stage with enhanced mission capabilities and reuse potential becomes possible as we discuss below.

#### “BIMODAL” NTR VEHICLE / MISSION CONCEPT

The bimodal NTR (BNTR) vehicle concept,<sup>10</sup> proposed in FY93, was examined in greater detail during this study to quantify its performance benefits and mission versatility, and to provide a point of comparison with the expendable TMI stage. A “modified” DRM scenario (Figure 15) was evaluated that employed BNTR transfer vehicles



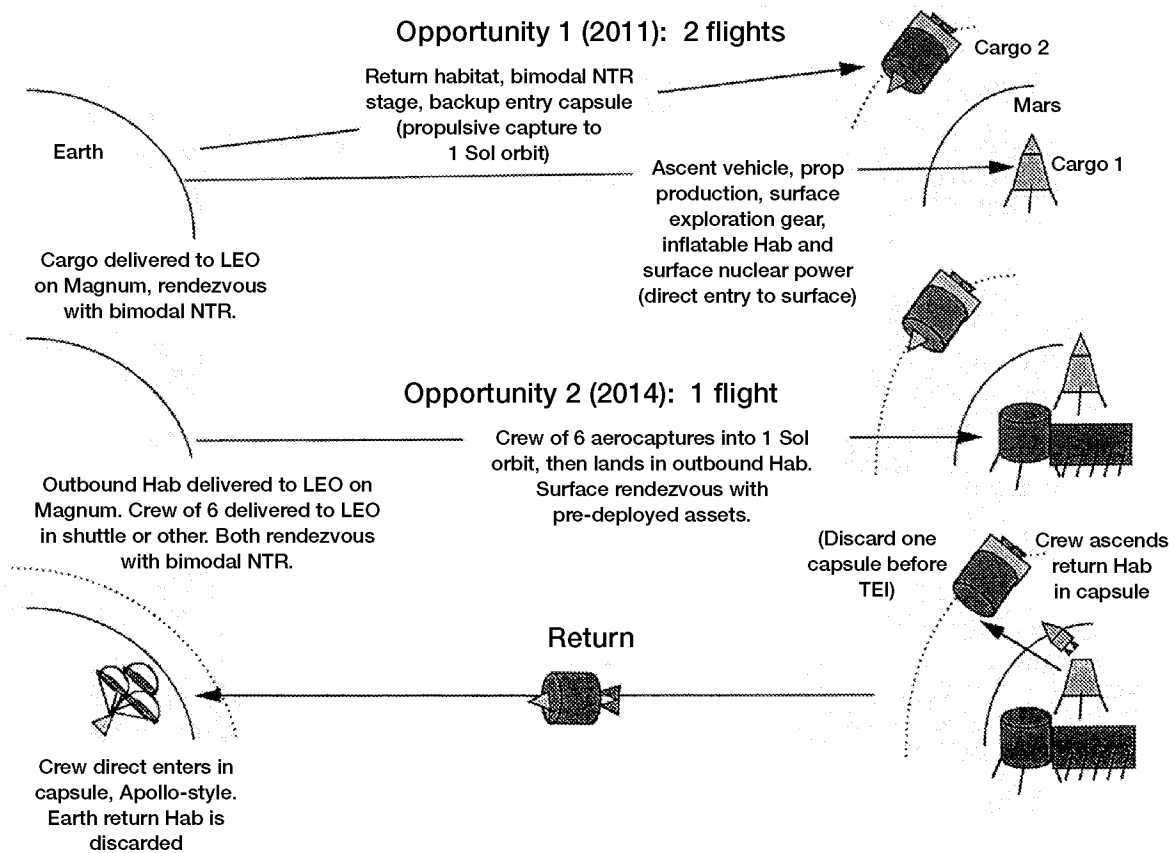

Figure 15.—"Modified" Mars Mission Profile Using Bimodal NTR Vehicle Concept.

in place of the expendable TMI stage option discussed above. A common "core" stage, used on cargo and piloted vehicles alike, is outfitted with three 15 klbf BNTR engines capable of providing up to 50 kWe using any two engines. Configured for launch on a single Magnum booster, the bimodal core stage is not jettisoned after the TMI maneuver but remains with the cargo and piloted payload elements providing them with both midcourse correction (MCC) propulsion and all necessary power during transit. As it nears Mars, the bimodal stage separates from the aerobraked payload and performs its final disposal maneuvers.

A key difference between the DRM and the bimodal option described here is the absence of the aerobraked LOX / CH<sub>4</sub> TEI stage which is replaced by an "all BNTR"-powered ERV illustrated in Figures 16 and 17. The bimodal core stage is connected to the hard-shelled ERV habitat module by a rigid, spine-like "saddle truss" to which a jettisonable "in-line" TMI propellant tank is attached. Propellant for the Mars orbit capture MOC and TEI burns is contained within the core stage LH<sub>2</sub> tank. The

554 days of contingency consumables carried by the ERV (in case an emergency crew abort to Mars orbit becomes necessary) is also attached to the rear of the hab module and can be easily jettisoned prior to TEI. In the DRM, sizeable doors must be opened on the ERV's integrated aerobrake in order to remove these excess consumables. Approximately 30 days after the core stage is launched, a second Magnum booster delivers the saddle truss, in-line propellant tank, hab module and consumables, to LEO where rendezvous and docking with the bimodal core stage takes place. Because of its higher performance engines (~940 s versus 379 s for LOX/CH<sub>4</sub> RL 10 engines), and the elimination of the large 30 kWe PVA (~3.6 t) and heavy aerobrake (~10.2 t), the BNTR / ERV is capable of a "single burn" Earth departure while also carrying a spare Earth return crew vehicle (ECRV) to Mars. This enhanced vehicle capability reduces mission risk by providing a backup option for Earth return should a problem arise that prevents the crew from landing on Mars and recovering their primary ECRV from the ascent stage. Adding a spare ECRV to the aerobraked ERV option increases its

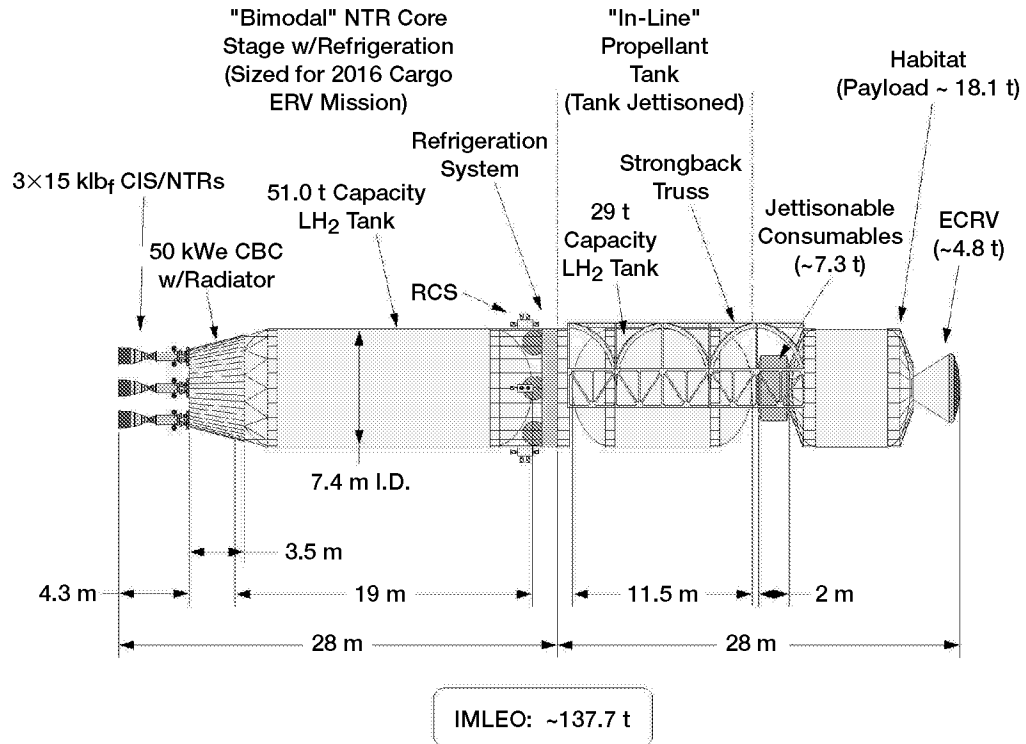

Figure 16.—Size, Mass and Key Features of BNTR-Powered ERV with Crew Habitat and Spare ECRV.

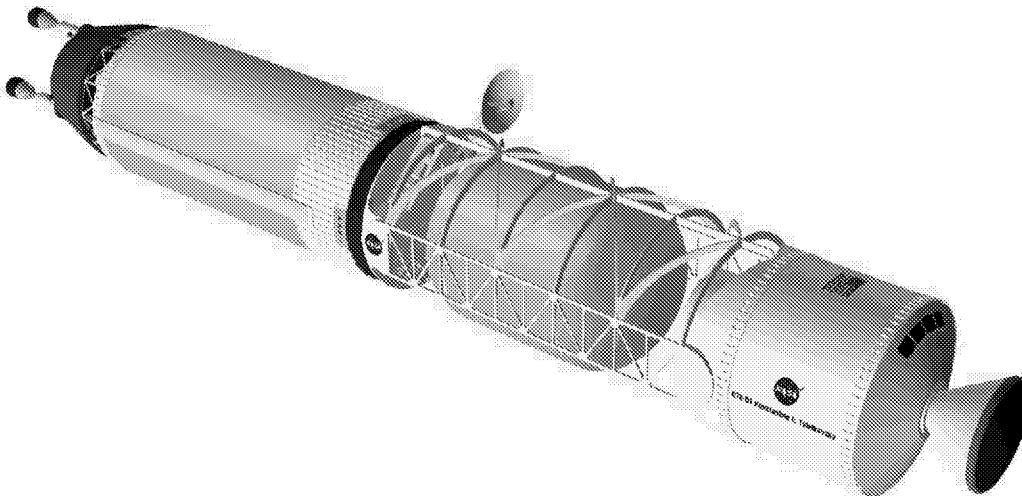

Figure 17.—3-D Image of BNTR/ERV with Spare ECRV.

IMLEO by an additional 10 t (from 147.5 to ~157.8 t) even using a “2 perigee burn” departure.

The bimodal core stage LH<sub>2</sub> tank is ~19 m long and has a maximum LH<sub>2</sub> propellant capacity of ~51 t using a 3% ullage factor. In addition to avionics, storable RCS and docking systems, a turbo-Brayton refrigeration system is also located in the stage forward cylindrical adaptor section to eliminate LH<sub>2</sub> boiloff during the lengthy (~4.2 year) ERV mission. To remove the ~75 watts of heat penetrating the 2 inch MLI system in LEO (where the highest tank heat flux occurs), the Brayton refrigeration system requires up to ~15 kWe. At the aft end of the bimodal core stage, a conical extension of the stage thrust structure provides support for a “common”, one-sided, pumped-loop heat rejection radiator system. Enclosed within this ~71 m<sup>2</sup> conical radiator is a closed Brayton cycle (CBC) power conversion system employing three 25 kWe Brayton rotating units (one for each bimodal reactor) which operate at ~2/3 of rated capacity and provide an “engine out” capability. The turbine inlet temperature of the working gas is ~1300 K and the Brayton system specific mass is estimated to be ~27 kg/kWe. A mass breakdown of the common BNTR core stage used in the “modified” DRM and the “all BNTR” mission scenarios described below is found in Table 8.

**Table 8. Mass Breakdown for “Common” Bimodal NTR Core Stage**

“Bimodal” NTR Core Stage Elements	Mass (t)
Structure	2.5
Avionics and Power	1.47
Reaction Control System (RCS)	0.45 - 0.48
Propellant Tank (7.4 m I.D. x 19.0 m lgth.)	5.98
Passive TPS (@2" MLI)/Micrometeor Shield	1.29
LH <sub>2</sub> Refrigeration System (@~75 Wt)	0.30
Brayton Power System (@ 50 kWe)	1.35
NTR Assemblies	
• 15 klbf CIS NTRs (3)	6.67
• External Radiation Shields (3)	0 - 2.82
• Propellant Feed, etc.	0.47
Contingency (15%)	3.07 - 3.50
“Dry” Bimodal Core Stage	23.55 - 26.83
LH <sub>2</sub> Propellant (max. LH <sub>2</sub> Capacity)	51.0
RCS Propellant	1.62 - 2.19
“Wet” Bimodal Core Stage	76.2 - 80.0

The bimodal transfer vehicle used for the cargo lander requires a much smaller in-line propellant tank and saddle truss arrangement (shown in Figure 18) than that used by the “3-burn” ERV mission, while the piloted lander requires only the bimodal core stage (see Figure 19). Because of the modest power needs currently identified for the cargo lander, payload mass reductions

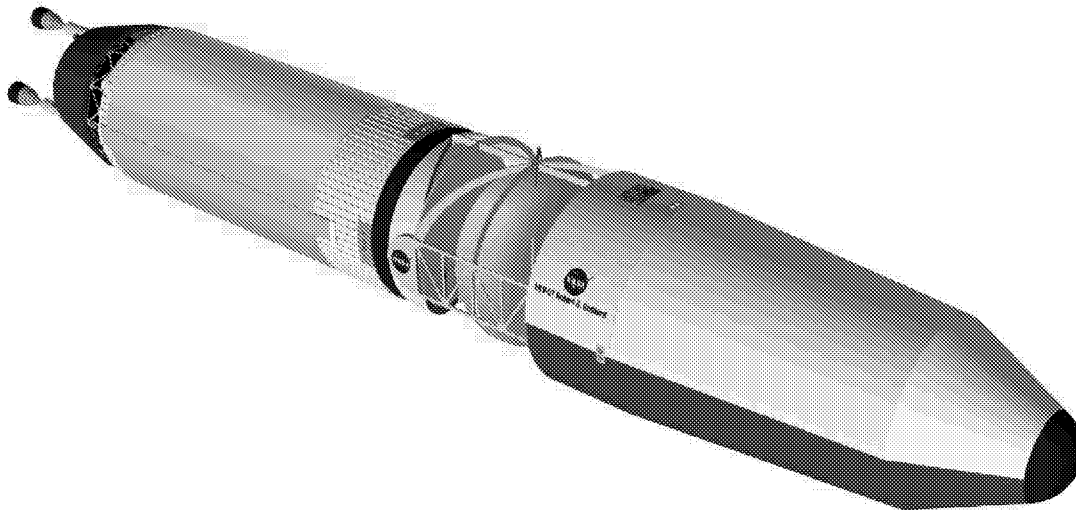

Figure 18.—3-D Image of BNTR Transfer Stage and Aerobraked Cargo Lander.

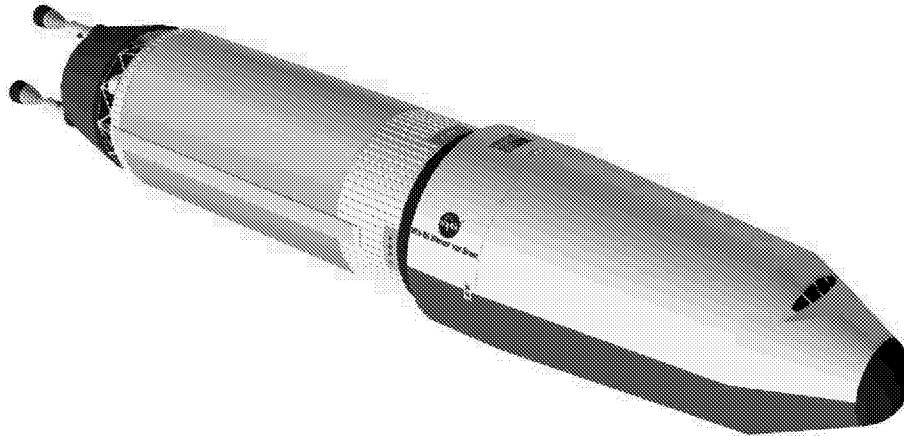

Figure 19.—3-D Image of BNTR Transfer Stage and Aerobraked Piloted Lander.

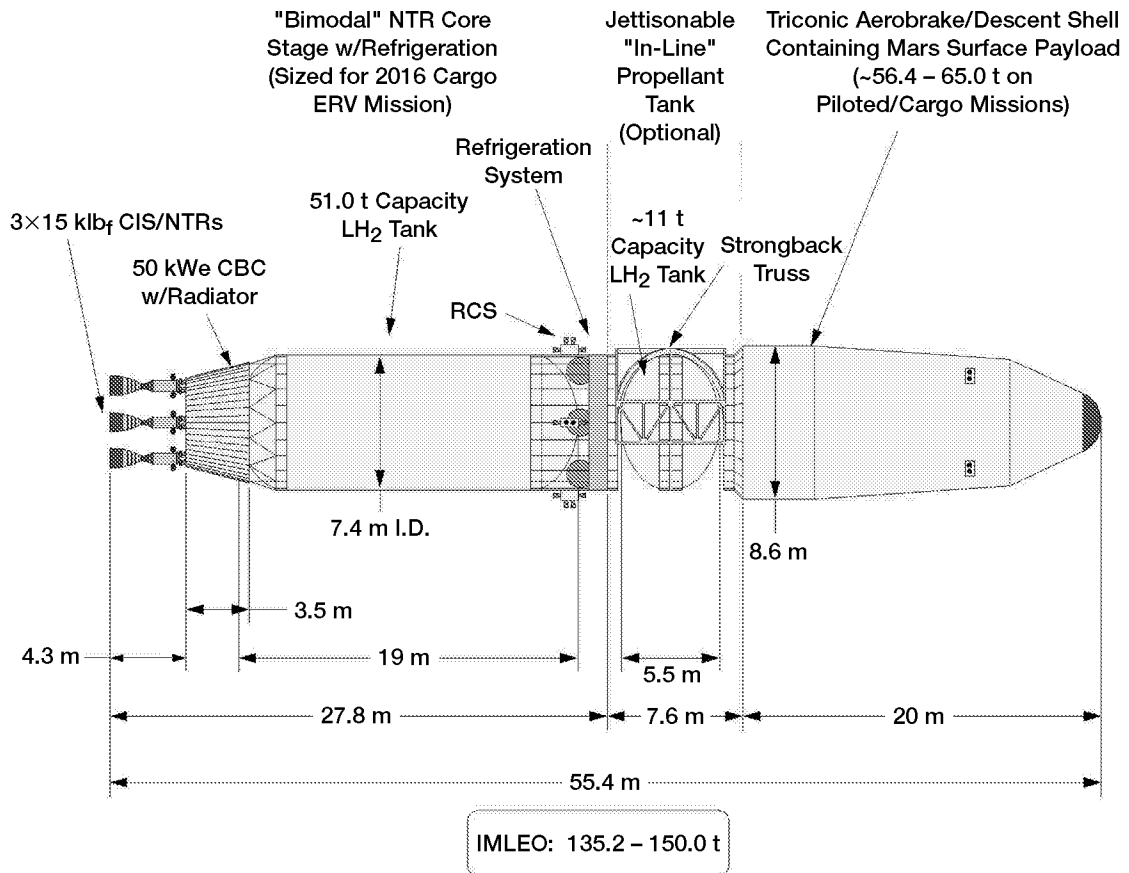

Figure 20.—Size, Mass and Key Features of BNTR Transfer Stage for Cargo and Piloted Lander Missions.

attributed to bimodal stage usage (see Figure 20) are small (~1 t) and associated with reduced propellant loading in the lander due to the absence of the MCC burn. However, the bimodal stage subsystems can support the cargo and piloted lander missions in a number of key ways not yet quantified. In addition to its 50 kWe power capability, the bimodal stage's LH<sub>2</sub> refrigeration system can be used to eliminate boiloff from the ~4.5 t of "seed" LH<sub>2</sub> required for ascent propellant and water production, and its heat rejection system can help to dissipate "decay heat" from the ~15 kWe dynamic isotope power system (DIPS) cart used to deploy the nuclear surface power system after landing. For the piloted lander mission, the elimination of the 30 kWe PVA and MCC propellant helps to decrease descent stage propellant requirements and aerobrake TPS mass resulting in an ~4.5 t reduction in piloted lander mass. As with the cargo lander mission, the bimodal stage's LH<sub>2</sub> refrigeration system could also be used to eliminate boiloff from the current LOX/CH<sub>4</sub> descent stage or a higher performance LOX / LH<sub>2</sub> stage.

Table 9 provides an IMLEO summary for the cargo lander, ERV and piloted lander missions using BNTR stages, and assuming a "single burn" Earth departure scenario. The ERV payload mass includes a spare ECRV and 554 days of contingency consumables (assuming 2.2 kg / day / person and a crew of six). Because of the ERV's lengthy mission duration and the need for multiple engine restarts to full power, the fuel temperature is held to 2900 K and the Isp to 940 s for conservatism. The 79 t core stage containing ~ 50 t of LH<sub>2</sub> is launched on the first Magnum booster. The second Magnum launch delivers the payload plus the 28.4 t saddle truss and in-line tank containing ~19.9 t of LH<sub>2</sub>. The BNTR engines used on the cargo and piloted lander missions are operated at the higher performance levels (~955 s). Of the ~55.2 t of LH<sub>2</sub> required for the cargo mission, a minimum of ~4.2 t would be located in the in-line tank. For the piloted lander mission, the entire propellant load (~50.2 t) is contained within the core stage. The total IMLEO for this "3 mission" bimodal scenario is 422.9 t — essentially identical to that of the DRM (Table 7) despite the more demanding requirements levied on the bimodal system.

A payload and stage mass comparison of the DRM and "modified" DRM under similar operating

conditions is shown in Table 10, and Figure 21 shows the relative size and mass of the bimodal NTR transfer vehicles used in the comparison. The IMLEO values assume a "2-perigee burn" Earth departure. Because the bimodal vehicles use "standardized" components, their reduced mass primarily reflects decreased propellant usage during the "2 burn" TMI maneuver. For the cargo lander mission, total propellant loading decreases from ~55.2 t (for "single burn" departure and Isp~955 s) to ~48.4 t (for Isp~940 s) eliminating the need for the small in-line tank (see Figure 21). In the case of the BNTR / ERV, the absence of the spare ECRV further decreases propellant loading to the point that the in-line tank is substantially off-loaded—only ~42% of its maximum propellant capacity.

Because of its higher performance and abundant power, the BNTR / ERV mass in LEO is ~26 tons lighter than the LOX / CH<sub>4</sub> TEI stage which requires two large (~8 meter x 45 meter) PVAs to provide ~30 kWe in Mars orbit. Using the BNTR / ERV option also eliminates the development and recurring costs of the chemical TEI stage and its 30 kWe PVA system, as well as the recurring cost of the aerobrake needed to place the heavy TEI stage into Mars orbit. On the cargo and piloted hab lander missions which utilize aerobraking, the common bimodal core stage provides both a 50 kWe power source and the MCC propulsion which helps reduce the size and mass of these payload elements. Bimodal operation also simplifies mission operations by eliminating the need for multiple solar array deployment / retraction cycles and the complexities of array pointing and tracking of the Sun during transit and while in Earth and Mars orbit. Overall, the bimodal approach has a lower "3 mission" IMLEO (~396 t versus 422 t for the DRM) while providing substantially more capability. It also provides one of the lowest cost and risk options for Mars exploration because it requires fewer major systems.

Lastly, the requirements on total engine burn time and fuel burnup are considered modest. For the most demanding BNTR / ERV mission (multiple burns and total mission duration ~4.2 years), the total engine burn time is ~50.8 minutes, assuming a "single burn" departure and a spare ECRV. The TMI burn is the longest at ~36.9 minutes, and includes the effect of a substantial gravity loss (estimated at ~345 m/s for C3 = 8.97 km<sup>2</sup> / s<sup>2</sup>,

**Table 9. Modified DRM “Three Mission” IMLEO Summary for Single Burn Earth Departure and Spare ECRV (IMLEO ≤ 160 t / 2 - 80 t Magnum / Shuttle C HLLVs)**

Payload/Vehicle Propulsion/Isp	Element Masses (t)	2011 Cargo Lander Mission	2011 ERV Mission	2014 Piloted Lander Mission
Earth Return Vehicle Payload	Crew Hab Module		18.15	
	Spare ECRV		4.83	
	Contingency Consumables		7.31	
Ascent Stage LOX/CH <sub>4</sub> Isp = 379 s (O/F = 3.5:1)	Crew (6) & Suits			1.44
	MAV Crew Cab/ECRV	4.83		
	Ascent Stage	4.06		
	Propellant*	38.40		
Descent Stage LOX/ CH <sub>4</sub> Isp = 379 s (O/F = 3.5:1)	Surface Payload	31.34		26.81
	Descent Stage	4.20		4.20
	Aerobrake/Descent Shell <sup>†</sup>	9.88		13.24
	Parachutes	0.70		0.70
	Propellant**	10.03		9.99
Total Payload Mass		65.04	30.29	56.38
Common NTR Vehicles w/ Modular Components CIS w/ LH <sub>2</sub> Isp = 940 - 955 s	CIS Engines (#)	7.67(3)	7.67(3)	7.67(3)
	F(klbf) per engine/Isp(s)	14.76/955	15/940	14.76/955
	Radiation Shields (#)		3.24(3)	3.24(3)
	“In-Line” TMI LH <sub>2</sub> Tank & Structure	4.26	8.52	
	TMI “Core” Stage Tank & Structure	11.77		11.77
	TMI/MOC/TEI “Core” Stage Tank & Structure		11.77	
	Brayton Power System (@ 50 kW <sub>e</sub> )	1.55	1.55	1.55
	LH <sub>2</sub> Refrigeration System***	0.34	0.34	0.34
	Avionics & Aux. Power	1.69	1.69	1.69
	Propellant****	55.24	69.84	50.19
RCS NTO/ MMH Isp = 320 s	Propulsion & Tankage	0.54	0.56	0.54
	Propellant	1.89	2.19	1.83
Total NTR Vehicle Mass		84.95	107.37	78.82
Total IMLEO		149.99	137.66	135.20

\* Produced at Mars using “in-situ” resources

\*\* Assumes parachutes and 632 m/s descent ΔV

\*\*\* Cooling capacity of “core” tank @ ~75 Wt

\*\*\*\* Contains boiloff, cooldown, “tank trapped” residual and disposal LH<sub>2</sub> also

<sup>†</sup> Using ARC Triconic aerobrake mass estimation formula (Table 2)

**Table 10. “Three Mission” IMLEO Comparison for DRM and “Modified” DRM Using BNTR**

NTR/Aerobrake (DRM) and “Modified” DRM: 80 t Magnum

Mission Feature(s): Uses JSC “Supplied” payload masses adjusted for “bimodal” NTR operation, fixed 4.2 t LOX/CH<sub>4</sub> descent stage, 0.7 t parachutes for descent assist ( $\Delta V_{desc} = 632$  m/s), and “2 Perigee Burn” Earth departure.

Magnum Launch	Flight Element	2011 Cargo Lander		2011 ERV *		2014 Piloted Lander		Totals	
		DRM	modified DRM **	DRM	modified DRM **	DRM	modified DRM **	DRM	modified DRM **
#1	Payload	66.0	65.0	74.1	25.5	60.8	56.4	200.9	146.9
	- Surface/“In-Space”	- 40.2	- 40.2	- 29.1	- 25.5	- 30.9	- 28.4	- 100.2	- 94.1
	- Transportation	- 25.8	- 24.8	- 45.0		- 29.9	- 28.0	- 100.7	- 52.8
	“In - Line” Propellant/Tankage (LH <sub>2</sub> and/or LOX)	-	-	-	20.8	-	-	-	20.8
#2	NTR TMI stage (“Modified” DRM uses “bimodal” NTRs)	71.1	73.9	75.4	79.0	75.0	75.6	221.5	228.5
	Total :	137.1	138.9	149.5	125.3	135.8	132.0	422.4	396.2
	# Magnums	2	2	2	2	2	2	6	6

- \* 2011 ERV mission using “bimodal” NTRs for MOC and TEI is lighter than DRM by ~24 t and eliminates DDT&E and recurring costs for LOX/CH<sub>4</sub> TEI stage, also recurring cost for 30 kWe PVA and aerobrake.
- \*\* Common “bimodal” NTR core stage provides 50 kWe power capability to the ERV, Cargo and Piloted lander missions. Also supplies MCC burns for these missions. For cargo lander, the “bimodal” stage refrigeration/heat rejection systems can be used to cryocool 4.5 t of “seed” LH<sub>2</sub> and dump “waste heat” from 15 kWe DIPS power cart.

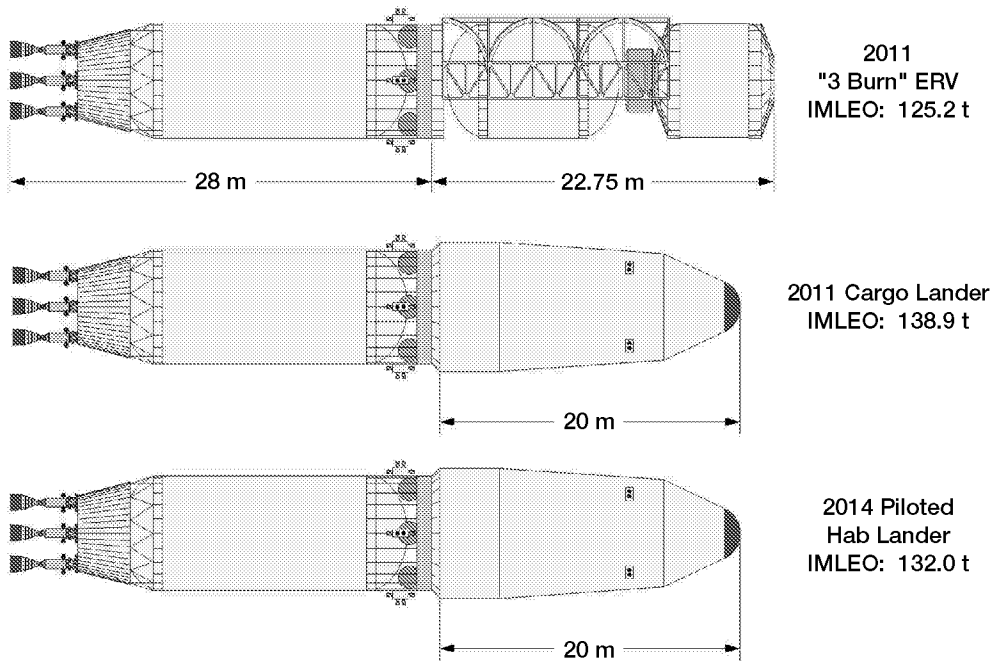

Figure 21.—BNTR Transfer Vehicles Used in Comparison with the DRM.

Isp~940 s, and a vehicle thrust-to-weight ratio of ~0.15). With regard to uranium-235 consumption, estimates indicate a fuel burnup of ~0.05% during the "propulsion mode" and ~0.73% during the "power mode" assuming a continuous 50 kWe power output from the three bimodal engines over a 5 year period.

**THE "ALL PROPULSIVE" BIMODAL NTR OPTION**

The next logical application of the BNTR stage beyond the modified DRM is propulsive capture of all payload elements into Mars orbit. This "all propulsive" NTR option makes the most efficient use of the bimodal engines which are now available to supply abundant power to spacecraft and payloads in Mars orbit for long periods. Even after payload separation and landing on the Mars surface, the core stages become valuable orbiting resources and can serve as high power communications relays and/or surface navigational aids. Propulsive capture into the reference "250 km by 1 sol" elliptical Mars parking orbit also makes it possible to design a standardized, reduced mass "aerodescent" shell for landing all payloads on the

Mars surface. From this reference parking orbit (similar to that used by the Viking lander missions in 1976), the payload entry velocity is ~4.5 km/s and the mass of the "triconic-shaped" aerodescent shell varies by only ~0.53 t over a payload mass range of 40 to 65 t (using equation in Table 2).

The size, mass and key vehicle features for the "all BNTR" Mars mission option is shown in Figure 22 and the associated cargo lander, ERV and piloted lander IMLEO values are summarized in Table 11. With propulsive capture, the total cargo lander mass decreases from ~66 t in the DRM to ~62.3 t, which is attributed to a lighter aerodescent shell (~8.2 t) and a reduced descent stage propellant loading (~8.9 t). A detailed "3 mission" IMLEO summary for the "all BNTR" option is found in Appendix Table A-4. Despite this mass reduction, the substantial payload carried by the cargo lander increases the propellant requirements on the BNTR transfer vehicle to ~68.3 t with the core stage holding 51 t. The remaining ~17.3 t of LH<sub>2</sub> is contained in the common 11.5 m in-line tank also used on the ERV and piloted lander missions. The total mass of the "in-line" tank , its propellant load

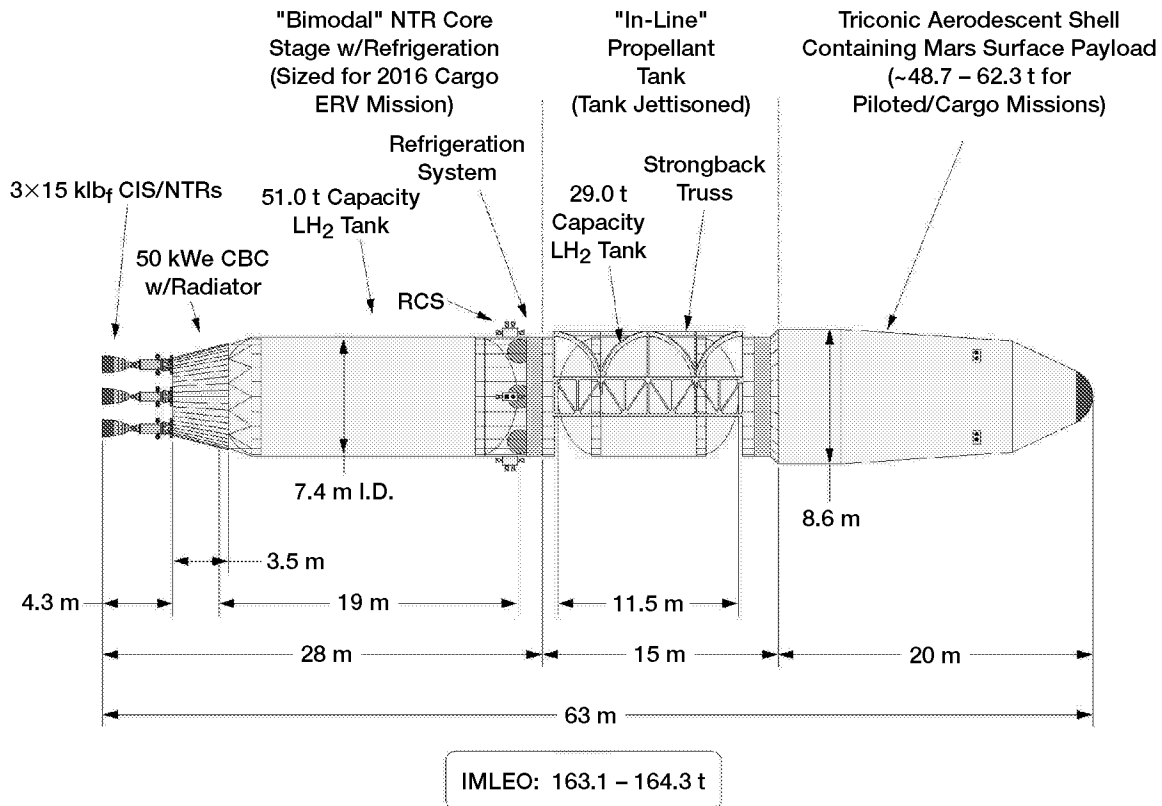

Figure 22.—Characteristics of "All BNTR" Transfer Vehicles for Piloted and Cargo Lander Missions.



Table 11. Payload/Stage Mass Manifest for “All BNTR” Option

Magnum Launch	Flight Element	2011 Cargo Lander*	2011 ERV	2014 Piloted Lander*	Totals
#1	Payload	62.3	25.5	48.7	136.5
	- Surface/“In-Space”	- 40.2	- 25.5	- 28.0	- 93.7
	- Transportation	- 22.1		- 20.7	- 42.8
	“In - Line” Propellant/Tankage (LH <sub>2</sub> and/or LOX)	25.8	20.8	35.0	81.6
#2	“Bimodal” NTR Core Stage	76.2	79.0	79.4	234.6
	Total :	164.3	125.3	163.1	452.7
	# Magnums	2	2	2	6

\* Common “bimodal” NTR core stage provides 50 kWe power capability to the ERV, Cargo and Piloted lander missions. Also supplies MCC burns for these missions. For cargo lander, the “bimodal” stage refrigeration/heat rejection systems can be used to cryocool 4.5 t of “seed” LH<sub>2</sub> and dump “waste heat” from 15 kWe DIPS power cart.

and the cargo lander determine the maximum lift requirement for the Magnum booster which is ~88 t for this mission option. Because the maximum possible payload length for the Magnum booster is ~33 m (including the 28 m cylindrical section and payload shroud nose cone), a smaller in-line tank or shortened triconic aeroshell length (to ~18 m) is required to launch these components on a single 88 t Magnum.

The piloted lander mission employs a “220 day” outbound transit time ( $C3 = 14.47 \text{ km}^2 / \text{s}^2$ ) to Mars to maintain LH<sub>2</sub> propellant requirements within the maximum propellant capacity provided by the common vehicle design. A “2-perigee” burn Earth departure is also assumed for all three missions to reduce gravity losses. With propulsive capture, the total piloted lander mass is decreased by ~20% (from ~61 t down to ~49 t). The main reductions are in the aerodescent shell mass (~7.9 t versus 13.6 t for the DRM) and the reduced descent stage propellant loading (~7.9 t compared to 11.4 t in the DRM). The piloted mission has longest total engine burn time at ~58 minutes. This includes 45 minutes for the 2 perigee burns, ~12 minutes for MOC, and an ~1 minute disposal burn to remove the bimodal core stage from Mars orbit after crew departure and send it into heliocentric space (see Table 5).

“ALL BNTR” OPTION USING “TRANSHAB”

The attractiveness of the “all propulsive” bimodal NTR option is further increased by the utilization of

the lightweight, inflatable “TransHab” module.<sup>12</sup> TransHab was designed to be launched in the Space Shuttle cargo bay fully outfitted. A central structural core ~3.4 m in diameter provides regenerative life support, thermal control, crew accommodations, avionics and communications, meteoroid and orbital debris protection, a storm shelter for crew radiation protection, and an airlock. Once on orbit, the outer shell surrounding the central core is inflated and corrugated flooring and partitions are deployed into place. Fully inflated, TransHab has an outer diameter of ~9.44 m, a height of ~9.65 m, and provides ~500 m<sup>3</sup> of habitable volume (see Figure 23).

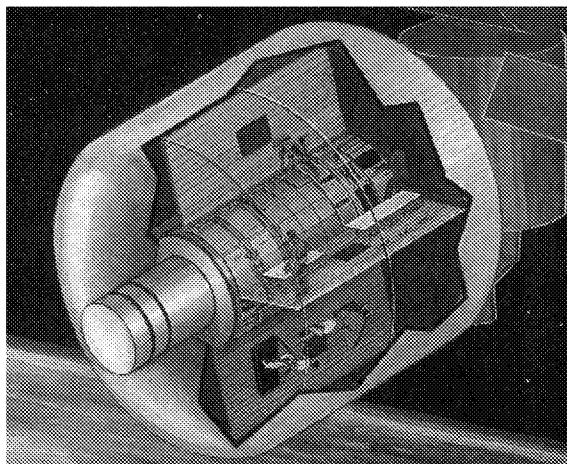

Figure 23.—Illustration Showing TransHab Module Attached to International Space Station.

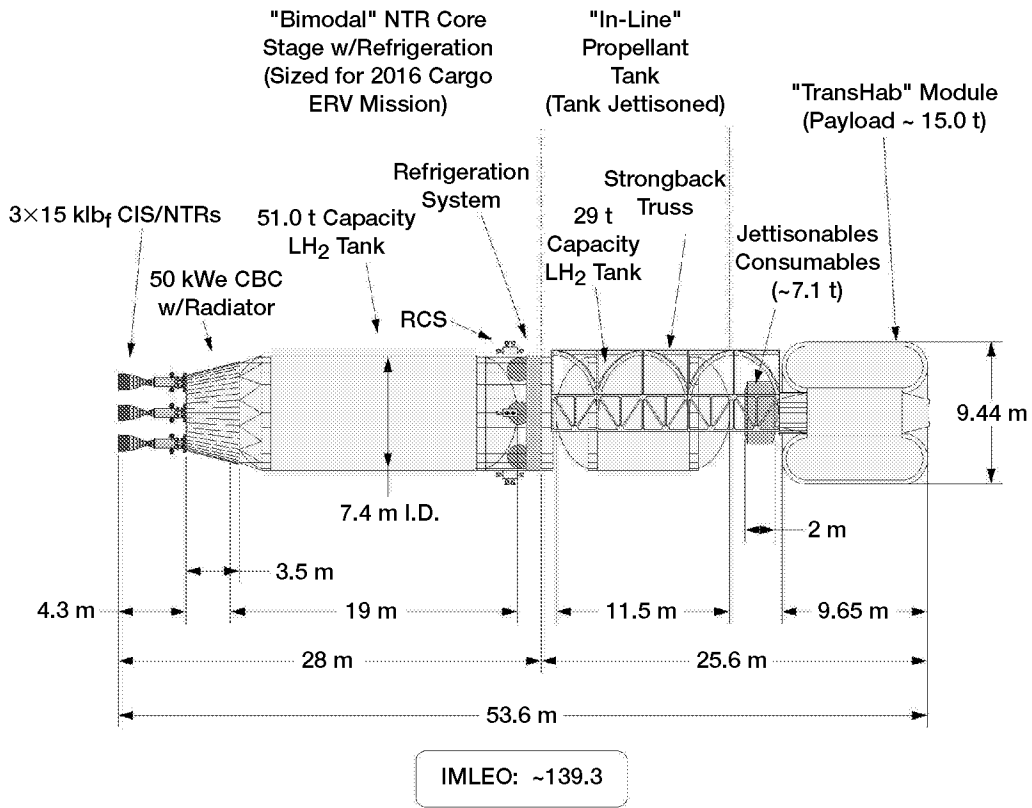

Figure 24.—Size, Mass and Key Features of Reusable Bimodal ERV Using TransHab.

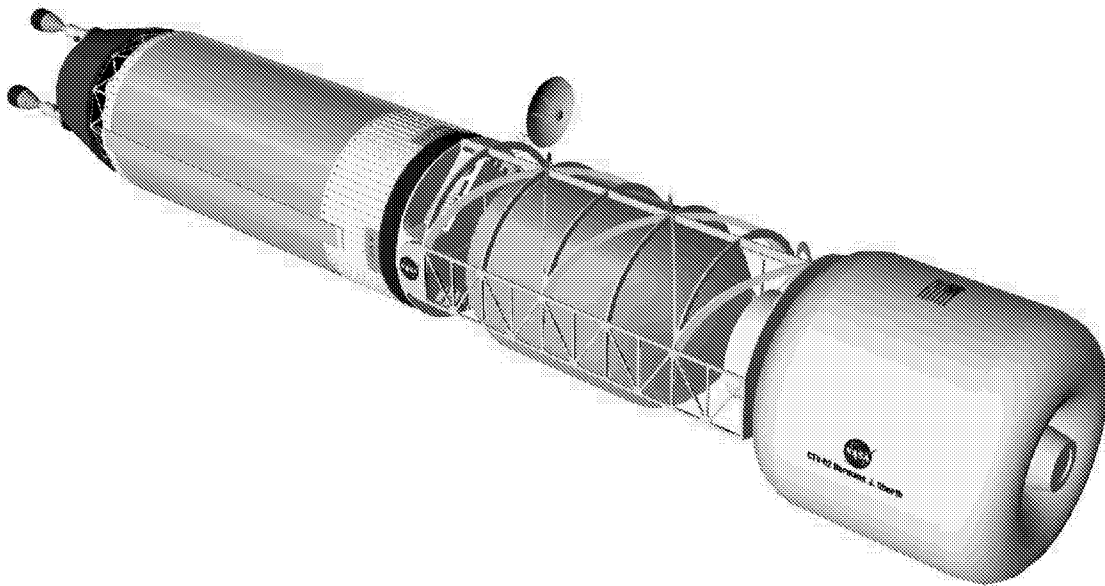

Figure 25.—3-D Image of Reusable Bimodal ERV with Inflatable TransHab Crew Module.

In addition to volume augmentation, the substitution of TransHab for the heavier, hard-shell hab module used on the bimodal ERV in Figures 16 and 17, provides an ~18% reduction in element mass and introduces the potential for propulsive recovery of the bimodal ERV in Earth orbit and its reuse on subsequent missions. The characteristics and 3-D image of the reusable bimodal ERV and TransHab crew module are shown in Figures 24 and 25, respectively. The reusable ERV departs Mars on February 7, 2016 and returns to Earth 180 days later on August 5, 2016. The crew reenters directly using the ECRV, while the ERV propulsively captures into a 500 km by ~71,136 km elliptical parking orbit with a period of ~24 hours. Using a 2-perigee burn departure, the reusable ERV mission utilizes nearly the full propellant capacity of the bimodal core stage and its in-line tank. At a hydrogen exhaust temperature of ~2900 K (Isp~940 s), the bimodal engines are estimated to have a "full power" operational lifetime of ~4.5 hours. With a total engine burn time of ~58 minutes for the four primary maneuvers, a multi-mission capability exists for the bimodal ERV. At Earth, a space-based upper stage could rendezvous with the ERV supplying it with a small in-line tank containing the propellant needed to return the ERV to LEO. Here, the core stage could be

refueled, a new in-line propellant tank attached, and necessary consumables provided for the next mission. Reuse of the core stage, saddle truss and TransHab would reduce vehicle recurring costs but must be evaluated against the increased development and operational costs of the support infrastructure.

Although the diameter of the aerodescent shell does not allow the same degree of volume augmentation available on the ERV mission, the use of TransHab on the piloted lander reduces its mass and allows the inflatable surface hab module on the cargo lander to be offloaded to the piloted mission. This and a 210 day outbound transit time results in a total propellant requirement of ~79.2 t with ~28.2 t located in the in-line tank. It is the combined "wet" in-line tank and piloted lander mass that sizes the Magnum lift capability at ~85 t. By offloading the inflatable surface hab from the cargo lander, the propellant loading in the bimodal transfer vehicle is also reduced to ~65.5 t. The payload and stage mass manifest for the two cargo and piloted flights are summarized in Table 12. The IMLEO values for the two lander missions reflect a 2-perigee burn departure and engine operation at an Isp value of 955 s.

**Table 12. Payload/Stage Mass Manifest for "All BNTR" Option Using TransHab**

Mission Feature(s): "Bimodal" NTR Core Stage provides power, MCC and all primary propulsion. ERV propulsively returned to Earth orbit. JSC "TransHab" masses for piloted lander and ERV. Fixed 4.2 t LOX/CH<sub>4</sub> descent stage and 0.7 t parachutes for descent assist ( $\Delta V_{desc} = 632$  m/s). Inflatable surface hab module (~3.1 t) is "offloaded" from the cargo to the piloted lander mission.

Magnum Launch	Flight Element	2011 Cargo Lander*	2011 ERV*	2014 Piloted Lander*	Totals
#1	Payload	58.5	22.0	47.9	128.4
	- Surface/"In-Space"	- 37.1	- 22.0	- 27.3	- 86.4
	- Transportation	- 21.4		- 20.6	- 42.0
	"In - Line" Propellant/Tankage (LH <sub>2</sub> and/or LOX)	23.0	37.3	36.7	97.0
#2	"Bimodal" NTR Core Stage	76.1	80.0	79.3	235.4
	Total :	157.6	139.3	163.9	460.8
	# Magnums	2	2	2	6

\* Common "bimodal" NTR core stage provides 50 kWe power capability to the ERV, Cargo and Piloted lander missions. Also supplies MCC burns for these missions. For cargo lander, the "bimodal" stage refrigeration/heat rejection systems can be used to cryocool 4.5 t of "seed" LH<sub>2</sub> and dump "waste heat" from 15 kWe DIPS power cart.

## MARS/PHOBOS MISSION OPTION USING LANTR

The benefits of a human expedition to Phobos have been discussed previously<sup>2,25</sup> and range from basic scientific knowledge to practical applications of the moon as an operating node and potential propellant depot for future human exploration and development activities on Mars. The Mariner 9 and Viking Orbiter missions in the 1970s provided images and spectral data suggesting that both Phobos and Deimos were formed within the asteroid belt and later captured by Mars. Their low mean densities ( $\sim 2 \text{ g/cm}^3$ ) and reflectivities<sup>26</sup> also suggest a chemical composition similar to carbonaceous chondrite meteorites, which contain substantial quantities of water and carbon-containing materials. Should this be true, Phobos could provide an abundant source of propellants for future reusable Mars transfer and landing vehicles. A Phobos mission would also provide expertise on operations both near and on a small, essentially gravity free planetary body of value to the exploration of other near Earth asteroids.

The introduction of LANTR and its integration into the bimodal stage opens the possibility for a "side trip" to Phobos within the current DRM. The reusable ERV mission just discussed showed the benefits of using TransHab. It also indicated, however, that the second Magnum booster was only utilizing  $\sim 75\%$  of its lift capability in launching TransHab, the in-line propellant tank and saddle truss (see Table 12). Stretching the in-line LH<sub>2</sub> tank size and propellant capacity is also limited because of the volume constraints of the Magnum payload shroud. Using LANTR engines at modest O/H mixture ratios increases bulk propellant density (by substituting high-density LOX for low-density LH<sub>2</sub>) and improves vehicle performance while staying within the available payload length limits. LANTR operation also helps to increase engine thrust, shorten burn times and extend engine life.

### Phobos Mission Description Using LANTR

The Phobos mission scenario utilizes LANTR engines only for Earth departure. At an operating temperature of 2900 K and an O/H MR = 0.0 (LH<sub>2</sub> only operation), the thrust from the LANTR engine is 15 klbf (see Figure 8). At an O/H MR = 0.5, the thrust per engine is increased by a factor of  $\sim 1.33$  while the Isp decreases from  $\sim 940 \text{ s}$  to  $831 \text{ s}$ . During the  $\sim 29$  minute long, 2-perigee burn TMI maneuver, the three LANTR engines produce a

total thrust of  $\sim 59.7 \text{ klbf}$  while using  $\sim 39.5 \text{ t}$  of LH<sub>2</sub> (including "cooldown" propellant) and  $\sim 19.2 \text{ t}$  of LOX. Following the TMI burn, the spent in-line LH<sub>2</sub> tank and two spherical LOX tanks attached to it are jettisoned from the saddle truss to reduce vehicle weight. On all subsequent burns, the LANTR engines operate at MR = 0.0 and Isp = 940 s. The bimodal LANTR vehicle concept with TransHab crew module is illustrated in Figure 26 and its corresponding 3-D image is shown in both Figure 27 and on our cover page.

At Mars, the LANTR transfer vehicle propulsively captures into a 250 km by 33,793 km elliptical parking orbit where it remains during most of the crew surface stay. Approximately 32 days before TEI, the LANTR ERV jettisons its  $\sim 6.3 \text{ t}$  of contingency consumables and then executes three propulsive maneuvers to rendezvous with Phobos. At apoapse, the LANTR engines burn to change plane to near equatorial. The required  $\Delta V$  is  $\sim 212 \text{ m/s}$  assuming an arrival declination of  $\sim 27$  degrees. Next, the periapse is raised to Phobos altitude of 5981 km ( $\Delta V \sim 228 \text{ m/s}$ ). A final circularization burn to lower apoapsis to 5981 km requires a  $\Delta V$  of  $\sim 664 \text{ m/s}$ . Including an additional  $\sim 100 \text{ m/s}$  to rendezvous with Phobos, the total  $\Delta V$  requirement is  $\sim 1105 \text{ m/s}$ .

Once in position, the crew lifts off from the Mars surface and rendezvouses with the LANTR / ERV to begin a month long investigation of Phobos. Detailed spectroscopic analysis and other scientific measurements (including impact probes and deep penetrating radar imaging) would be carried out onboard the ERV to determine whether or not water is present. Prior to TEI, the ERV departs its near-equatorial orbit and returns to an inclined elliptical orbit matching the declination for the outgoing launch asymptote. The same  $\sim 1105 \text{ m/s}$  is assumed for these return maneuvers. The total IMLEO for the LANTR / ERV mission to Phobos is  $\sim 157.9 \text{ t}$  with each Magnum booster now delivering  $\sim 79 \text{ t}$  to LEO (see Table 13). The cargo lander mission is unchanged from Table 12 and the piloted lander mass decreases slightly due to the shortened surface stay time ( $\sim 475$  days) and reduced crew consumables required for the Phobos mission.

By stretching the LANTR / ERV in-line LH<sub>2</sub> tank size and capacity to  $\sim 13.5 \text{ m}$  and  $35 \text{ t}$  to increase performance, a more robust Phobos exploration scenario is possible. Rather than relying on remote data acquisition alone, the "stretch" LANTR / ERV

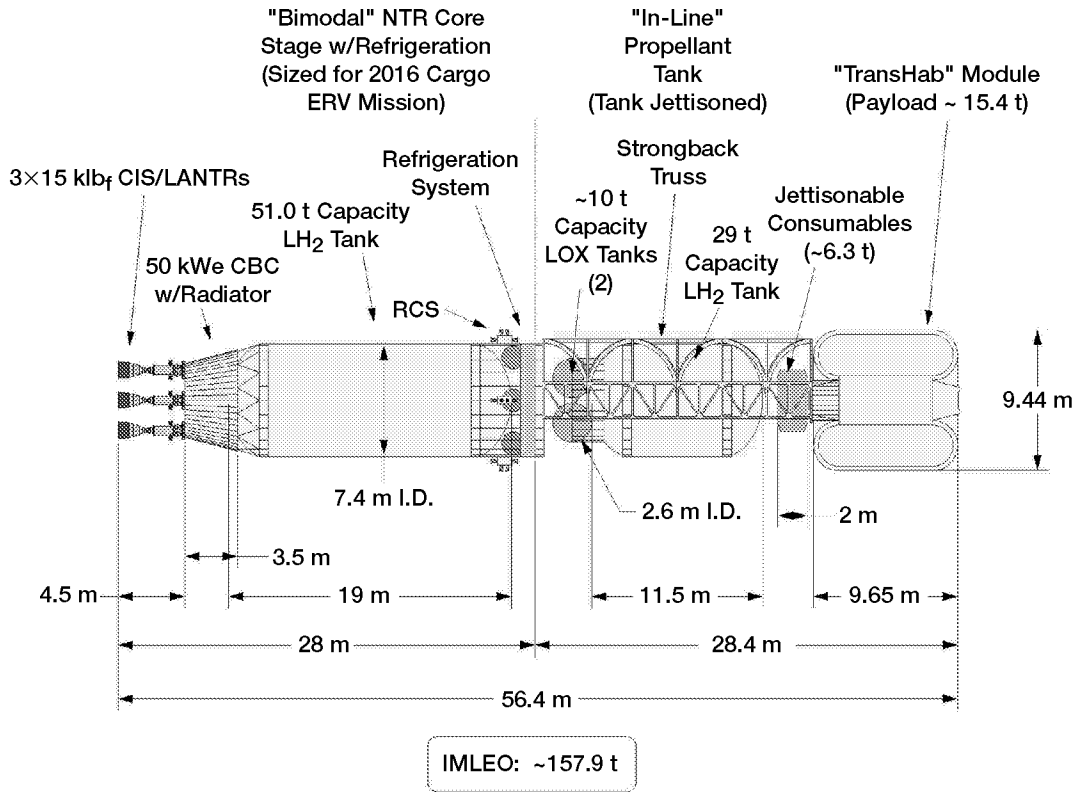

Figure 26.—Size, Mass and Key Features of Bimodal LANTR Transfer Vehicle for Mars/Phobos Mission Option.

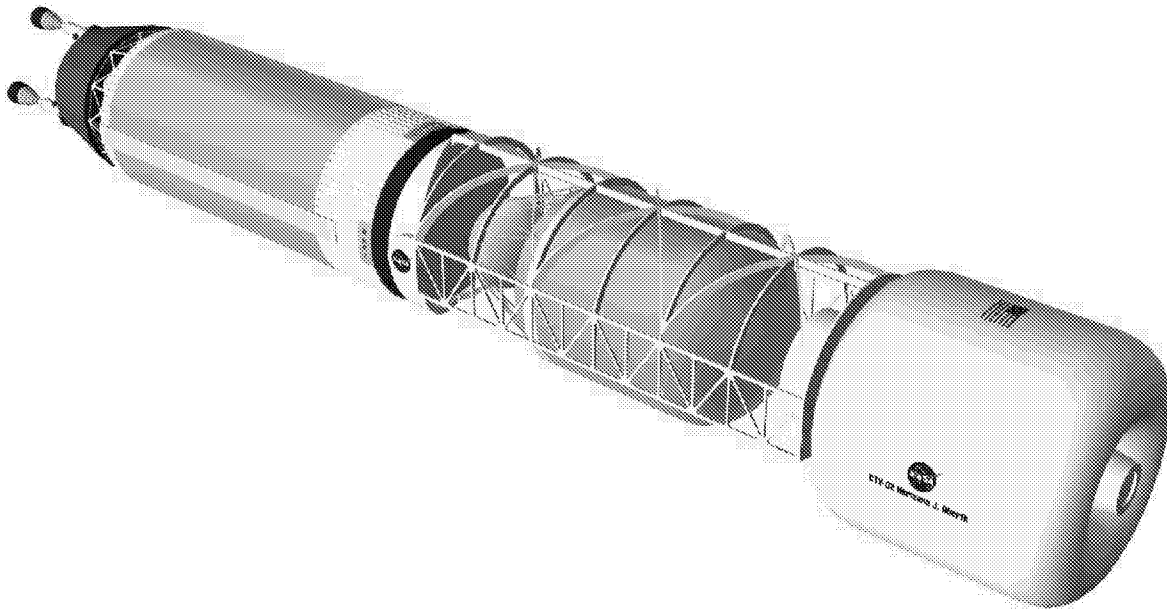

Figure 27.—3-D Image of Bimodal LANTR Transfer Vehicle for Mars/Phobos Mission Option.

**Table 13. Payload/Stage Mass Manifest for Bimodal “LANTR” Mars/Phobos Option**

Mission Feature(s): Bimodal “LANTR”-powered ERV visits Phobos before TEI. LANTR engines provide thrust augmentation (MR = 0.5) for TMI with MR = 0 for remaining primary propulsive maneuvers. “TransHab” mass used on ERV and piloted mission. Fixed 4.2 t LOX/CH<sub>4</sub> descent stage and 0.7 t parachutes for descent assist ( $\Delta V_{desc} = 632$  m/s).

<u>Magnum Launch</u>	<u>Flight Element</u>	<u>2011 Cargo Lander*</u>	<u>2011 ERV* (Visits Phobos)</u>	<u>2014 Piloted Lander*</u>	<u>Totals</u>
#1	Payload	58.5	21.7	47.0	127.2
	- Surface/“In-Space”	- 37.1	- 21.7	- 26.6	- 85.4
	- Transportation	- 21.4		- 20.4	- 41.8
	“In - Line” Propellant/Tankage (LH <sub>2</sub> and LOX)	23.0	57.0	35.8	115.8
#2	“Bimodal” NTR Core Stage	76.1	79.2	79.3	234.6
	Total :	157.6	157.9	162.1	477.6
	# Magnums	2	2	2	6

\* Common “bimodal” NTR core stage provides 50 kWe power capability to the ERV, Cargo and Piloted lander missions. Also supplies MCC burns for these missions.

(shown in Figure 28) would carry a 2-person “multiple sortie” lander and ~250 kg of scientific equipment to Phobos orbit. The ~6.3 t of contingency consumables are also transported to Phobos orbit to build up an easily accessible emergency food cache thereby allowing subsequent missions to transport an inflatable surface hab and other equipment needed to establish a permanent foothold on Phobos. The Phobos lander (shown to scale in Figure 28) is sized for ten round trip sorties to the surface of Phobos and back. On each mission, two astronauts deploy ~25 kg of scientific equipment and return to the ERV with ~10 kg of samples. Because the escape velocity from Phobos is very low (~15 m/s), the total storable propellant requirements for the entire ten mission set is only ~160 kg. The ~1.73 t Phobos lander mass includes the “dry” lander (at ~1.10 t) and its propellant load (~0.16 t), two EVA suits with life support (~0.22 t) and scientific equipment (~0.25 t). The payload / stage mass manifest for this robust Phobos option is provided in Table 14 and the associated “3 mission” IMLEO summary in Table 15. To compensate for the increased propellant loadings in the in-line LH<sub>2</sub> and LOX tank sets, the TransHab crew module and 32 days of extra consumables (totaling ~15.4 t) are delivered to the ERV using the Space Shuttle or “lower cost” RLV.

The remaining ~155.6 t are launched on two Magnums.

AN “ALTERNATIVE MISSION PROFILE” USING BNTR AND TRANSHAB

The BNTR transfer vehicle in combination with TransHab provides a high degree of mission versatility. In addition to providing a reuse capability for the ERV, a Phobos mission option is also possible through the addition of LOX “afterburner” nozzles and propellant feed system for LANTR operation. The BNTR and TransHab combination also allows one to consider an alternative mission profile in which the crew travels to and from Mars on the same bimodal transfer vehicle as depicted schematically in Figure 29. This approach cuts the duration of the ERV mission approximately in half—from ~4.7 to 2.5 years—while the remaining two mission elements (the cargo and “unpiloted” crew lander) are left unattended by humans for no more than ~2.8 years.

The roundtrip piloted transfer vehicle departs Earth on January 21, 2014 ( $C3 = 15.35$  km<sup>2</sup> / s<sup>2</sup>) and propulsively captures into Mars orbit 210 days later on August 19, 2014. The outbound transit time is extended by 30 days to maintain propellant requirements within the capacity of the bimodal

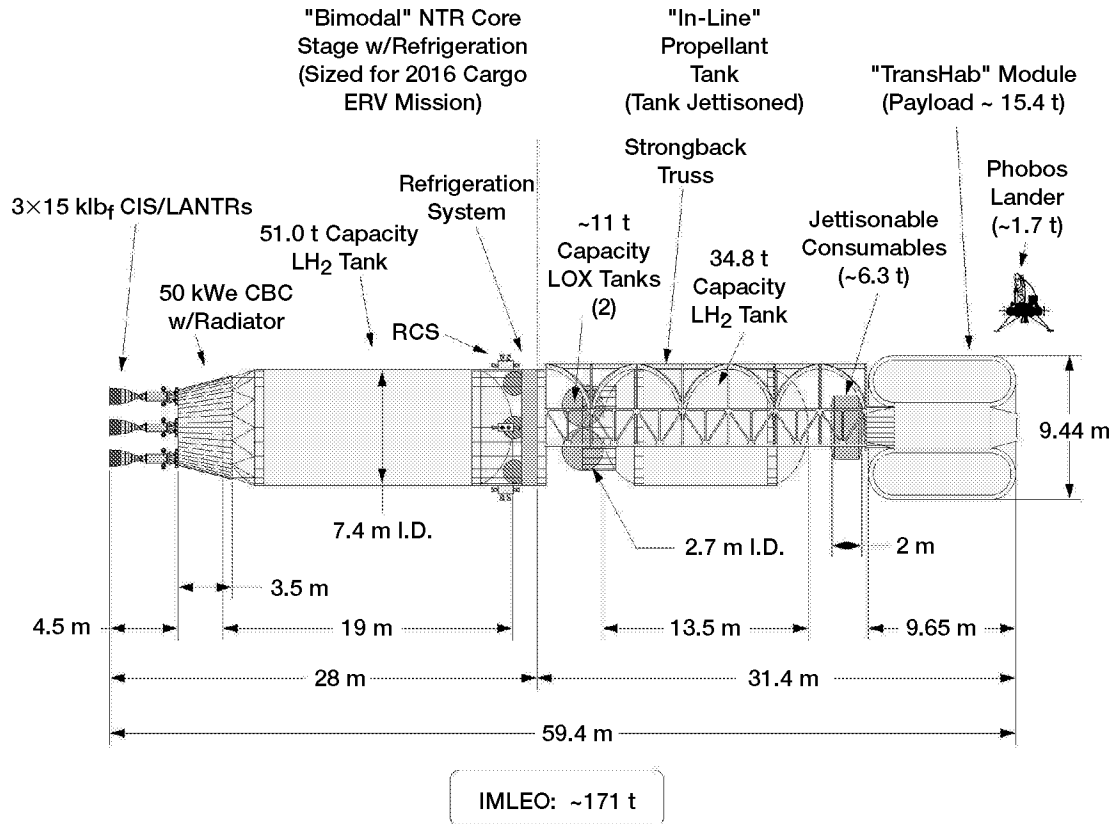

Figure 28.—Size, Mass and Key Features of "Stretch" LANTR/ERV for Phobos Lander Option.

Table 14. Mass Manifest for "Stretch" LANTR/Phobos Lander Mission

Mission Feature(s): Bimodal "LANTR"-powered ERV visits Phobos before TEI. LANTR engines provide thrust augmentation (MR = 0.5) for TMI with MR = 0 for remaining primary propulsive maneuvers. "TransHab" mass used on ERV and piloted mission. Fixed 4.2 t LOX/CH<sub>4</sub> descent stage and 0.7 t parachutes for descent assist ( $\Delta V_{desc} = 632$  m/s). ERV also carries "2 person" multiple sortie Phobos lander and scientific equipment.

Magnum Launch	Flight Element	2011 Cargo Lander*	2011 ERV* (Visits Phobos)	2014 Piloted Lander*	Totals
#1	Payload	58.5	23.4	47.0	128.9
	- Surface/"In-Space"	- 37.1	- 23.4	- 26.6	- 87.1
	- Transportation	- 21.4		- 20.4	- 41.8
	"In - Line" Propellant/Tankage (LH <sub>2</sub> and LOX)	23.0	68.4	35.8	127.2
#2	"Bimodal" NTR Core Stage	76.1	79.2	79.3	234.6
	Total :	157.6	171.0*	162.1	490.7
	# Magnums	2	2*	2	6

\* Common "bimodal" NTR core stage provides 50 kWe power capability to the ERV, Cargo and Piloted lander missions. Also supplies MCC burns for these missions. For cargo lander, the "bimodal" stage refrigeration/heat rejection systems can be used to cryocool 4.5 t of "seed" LH<sub>2</sub> and dump "waste heat" from 15 kWe DIPS power cart.

+ On 2011 ERV mission, "TransHab" module and extra consumables (~15.4 t) would be launched on Shuttle or lower cost RLV with remaining mass (~155.6 t) launched on two Magnums.

**Table 15. IMLEO Summary for Phobos Lander Option Using  
 ("Single Burn" Earth Departure Scenario)  
 (IMLEO ≤ 166 t / 2-83 t Magnum/Shuttle C HLLVs)**

Payload/Vehicle Propulsion/Isp	Element Masses (t)	2011 Cargo Lander Mission	2011 ERV Mission	2014 Piloted Lander Mission
Earth Return Vehicle Payload	"TransHab" Module†		14.96	
	Extra Consumables†		0.42	
	Contingency Consumables		6.27	
	Phobos Lander & Science Equipment		1.73	
Ascent Stage LOX/CH <sub>4</sub> Isp = 379 s (O/F = 3.5:1)	Crew (6) & Suits			1.44
	MAV Crew Cab/ECRV	4.83		
	Ascent Stage	4.06		
	Propellant*	38.40		
Descent Stage LOX/CH <sub>4</sub> Isp = 379 s (O/F = 3.5:1)	Surface Payload	28.24		25.14
	Descent Stage	4.20		4.20
	Aerodescent Shell <sup>+</sup>	8.15		7.90
	Parachutes	0.70		0.70
	Propellant**	8.30		7.62
Total Payload Mass		58.48	23.38	47.00
Common NTR/LANTR Vehicles  w/ Modular Components  LH <sub>2</sub> NTR Isp = 940 s  LANTR Isp = 831s @ MR=0.5 for TMI	NTR/LANTR Engines (#)	7.67(3)	8.13(3)	7.67(3)
	F(klbf) per engine/Isp (s)	14.76/955	19.9/831 15/940	14.76/955
	Radiation Shields (#)		3.24(3)	3.24(3)
	"In-Line" TMI LH <sub>2</sub> Tanks & Structure	8.25	9.88	8.25
	"In-Line" TMI LOX Tanks & Structure		0.49	
	TMI "Core" Stage Tanks & Structure	11.77		11.77
	TMI/MOC/TEI "Core" Stage Tanks & Structure		11.77	
	Brayton Power System (@ 50 kWe)	1.55	1.55	1.55
	LH <sub>2</sub> Refrigeration System***	0.60	0.34	0.60
	Avionics & Aux. Power	1.69	1.69	1.69
	LH <sub>2</sub> Propellant****	65.54	85.34	78.26
	LOX Propellant		22.20	
	RCS NTO/ MMH Isp = 320 s	Propulsion & Tankage	0.52	0.57
Propellant		1.55	2.38	1.54
Total NTR Stage Mass		99.14	147.58	115.09
Total IMLEO		157.61	170.96	162.09

† Delivered on Shuttle or lower cost RLV

\* Produced at Mars using "in-situ" resources

\*\* Assumes parachutes and 632 m/s descent ΔV

\*\*\* Cooling capacity of "core"/"in-line" tank @ ~75/46 W<sub>t</sub>, respectively

\*\*\*\* Contains boiloff, cooldown, "tank trapped" residual and disposal LH<sub>2</sub> also

+ Using ARC Triconic aerobrake mass estimation formula with V<sub>∞</sub>=4.5 km/s



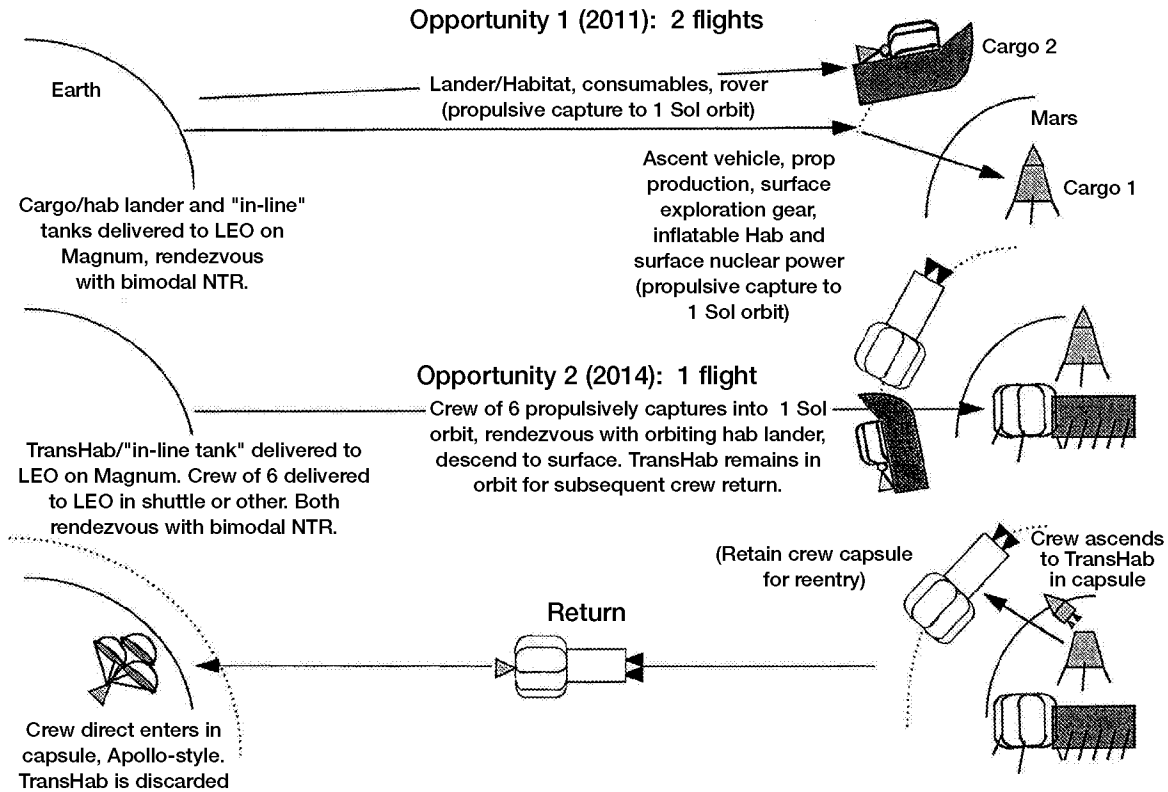

Figure 29.—"Alternative Mission Profile": Round Trip Piloted Transfer Vehicle Using BNTR and TransHab.

core stage (~51 t) and its 11.5 m "in-line" tank (~29 t). Table 16 shows the outbound piloted transit times possible over a 15 year period using the common bimodal transfer vehicle. Return transit times are held constant at 180 days.

Once in Mars orbit, the crew transfer vehicle (CTV) rendezvous with the "unpiloted" hab lander (which is now delivered on an earlier cargo mission) and then descends to the surface. The absence of crew on the hab lander mission eliminates the need for 210 days of outbound consumables (~2.77 t) and the engine crew radiation shields (~3.24 t). This allows the hab lander to carry the inflatable surface module (~3.1 t) and science equipment (~4.4 t) previously carried on the crowded cargo lander. Size, mass and key features of the bimodal vehicles used on the piloted and cargo / hab lander missions are shown in Figures 30 and 31, respectively.

The piloted transfer vehicle uses the same common core stage, in-line propellant tank and saddle truss utilized on the bimodal ERVs discussed previously. The TransHab payload mass

(~16.8 t) includes the mass of the six crew and their suits, and 30 days of extra consumables to account for the longer outbound transit time. Contingency consumables (~6.7 t) consistent with a 507 day surface stay are also carried. The total propellant required for the mission is ~79 t, and the total vehicle length and IMLEO are ~54 m and ~140 t, respectively. A smaller (~6.5 m), in-line propellant tank is used on the common bimodal transfer vehicles that deliver the ~46 t hab and ~54 t cargo landers into Mars orbit. The total propellant needs for these transfer vehicles are ~57.3 t and ~64.3 t, respectively. A 3-D image of the bimodal cargo transfer vehicle showing its relative size is shown in Figure 32, and Table 17 summarizes the payload / stage mass manifest for the "3 mission" set. A detailed IMLEO summary is found in Appendix Table A-5.

#### SUMMARY COMMENTS AND DISCUSSION

The bimodal NTR propulsion and power system provides an extremely versatile space transportation option to the planners and designers of future human exploration missions to Mars.

Table 16. Outbound  $\Delta V$  Variation with Trip Time and Departure Year for Piloted Mission

Outbound Trip Time (Days)	Burn	Departure Year									
		2009	2011	2014	2016	2018	2020	2022	2024		
220	TMI	4.075	3.919	3.823	3.841	3.535	3.857	4.089	4.109		
	MOC	1.515	1.672	1.629	1.569	1.090	0.862	1.000	1.390		
210	TMI	4.151	4.029	3.861	3.759	3.531	3.813	4.088	4.165		
	MOC	1.717	1.851	1.720	1.496	1.059	0.857	1.117	1.581		
200	TMI	4.248	4.154	3.949	3.729	3.531	3.798	4.114	4.244		
	MOC	1.946	2.064	1.856	1.510	1.057	0.882	1.260	1.799		
190	TMI	4.364	4.296	4.068	3.754	3.542	3.806	4.164	4.344		
	MOC	2.209	2.315	2.032	1.578	1.080	0.936	1.432	2.048		
180	TMI	4.503	4.458	4.214	3.821	3.567	3.835	4.239	4.468		
	MOC	2.511	2.608	2.251	1.689	1.129	1.019	1.635	2.335		
170	TMI	4.667	4.643	4.387	3.924	3.611	3.885	4.339	4.617		
	MOC	2.86	2.953	2.519	1.839	1.204	1.133	1.877	2.665		
160	TMI	4.860	4.855	4.587	4.059	3.675	3.956	4.466	4.796		
	MOC	3.263	3.356	2.843	2.034	1.308	1.280	2.161	3.048		
150	TMI	5.088	5.101	4.821	4.228	3.764	4.050	4.625	5.010		
	MOC	3.732	3.828	3.232	2.280	1.447	1.467	2.497	3.495		
140	TMI	5.362	5.391	5.094	4.434	3.880	4.174	4.822	5.268		
	MOC	4.281	4.382	3.699	2.586	1.626	1.700	2.897	4.016		
130	TMI	5.694	5.738	5.416	4.684	4.029	4.331	5.065	5.583		
	MOC	4.924	5.037	4.261	2.967	1.857	1.990	3.375	4.63		
120	TMI	6.103	6.162	5.804	4.987	4.218	4.530	5.367	5.971		
	MOC	5.683	5.810	4.938	3.441	2.152	2.352	3.948	5.355		

Note: Earth departure orbit 407 x 407 km / Mars capture orbit 250 km x 33,793 km  $\Delta V$ s do not contain any mid-course correction burn contribution.

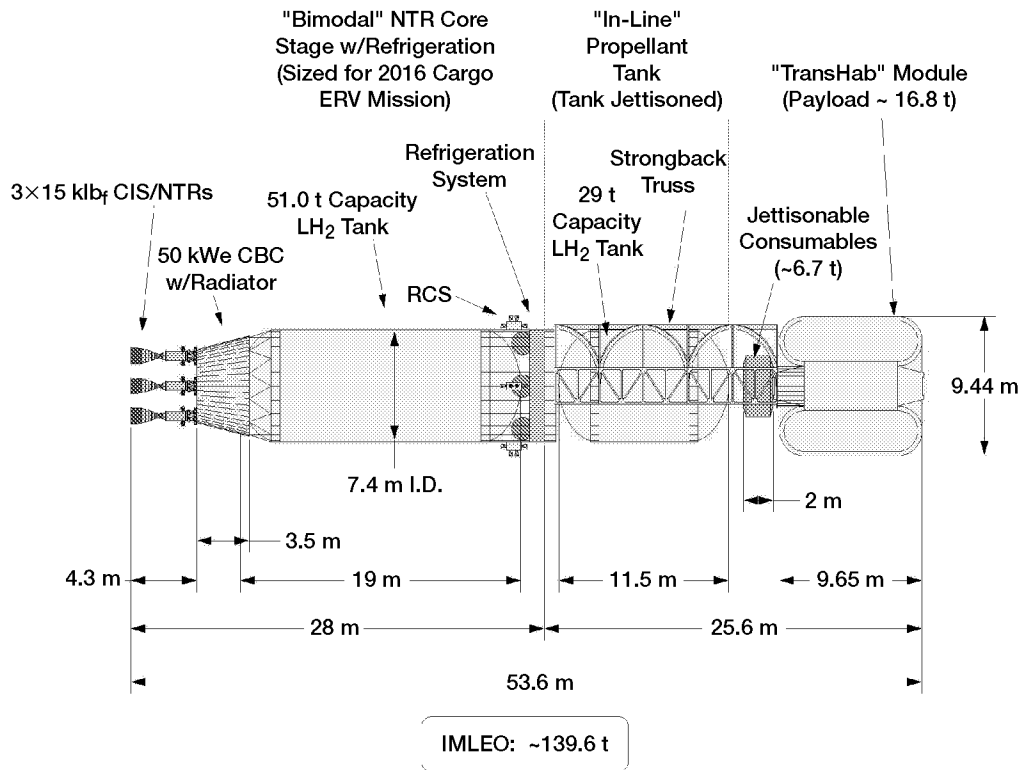

Figure 30.—Size, Mass and Key Features of Round Trip Piloted Transfer Vehicle.

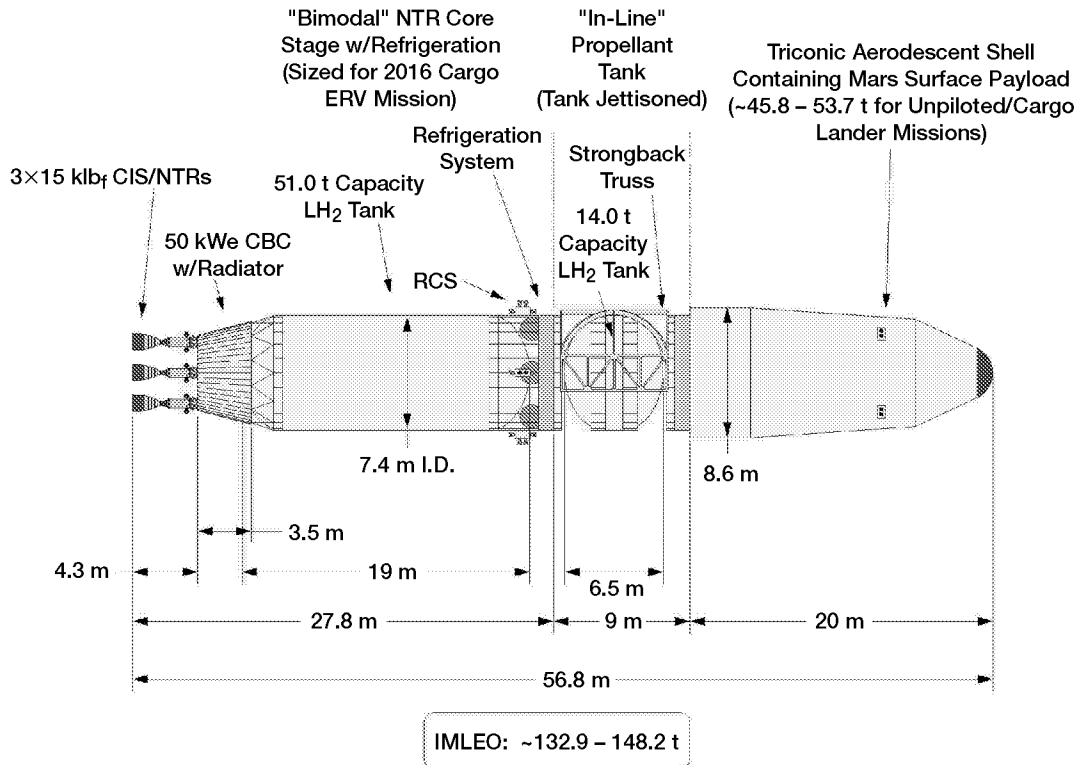

Figure 31.—Size, Mass and Key Features of BNTR Vehicles for Cargo and "Unpiloted" Hab Lander Missions.

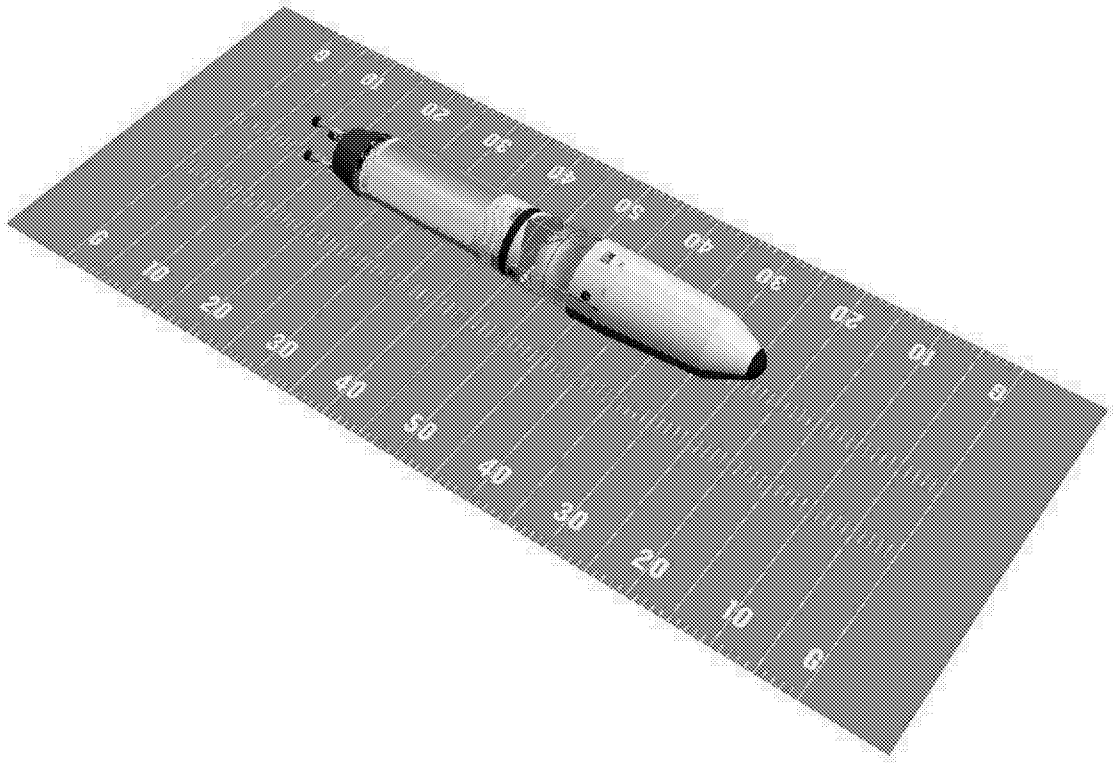

Figure 32.—3-D Image Showing Relative Size of Bimodal Cargo Transfer Vehicle.

Table 17. Payload/Stage Mass Manifest for Alternative Mission Option

Mission Feature(s): Crew travels to and from Mars using “bimodal” NTR transfer stage and “TransHab.” Results based on JSC “supplied” payload masses adjusted for “bimodal” NTR operation, fixed 4.1 t LOX/CH<sub>4</sub> descent stage and 0.7 t parachutes for descent assist ( $\Delta V_{\text{desc}} = 632$  m/s). A “Single Burn” Earth departure is used along with outbound/inbound transit time of 210/180 days, respectively.

<b>Magnum Launch</b>	<b>Flight Element</b>	<b>2011 Cargo Lander**</b>	<b>2011 “Unpiloted” Hab Lander**</b>	<b>2014 Piloted Mission*</b>	<b>Totals</b>
#1	Payload	53.7	45.8	23.5	123.0
	- Surface/“In-Space”	- 33.3	- 25.4	- 23.5	- 82.2
	- Transportation	- 20.4	- 20.4	-	- 40.8
#2	“In - Line” Propellant Tankage/Structure (LH <sub>2</sub> and/or LOX)	18.4	11.2	37.1	66.7
	“Bimodal” NTR Core Stage	76.0	75.8	79.0	230.8
	Total :	148.1	132.8	139.6	420.5
	# Magnums	2	2	2	6

\* 2014 Piloted “round trip” transfer vehicle uses “bimodal” NTRs for MOC and TEI also, and eliminates the DDT&E and recurring costs for the LOX/CH<sub>4</sub> TEI stage, as well as recurring cost for the 30 kWe PVA and aerobrake.

\*\* Common “bimodal” NTR transfer stage also provides 50 kWe power capability to the cargo and “unpiloted” Hab lander missions. Also supplies MCC burns for these missions.

Bimodal operation fully exploits the true performance potential of the NTR by tapping into the “rich source of energy” that exists within the engine’s reactor core. Rather than throwing away a valuable transportation system asset after a single use, “better systems engineering” has led to the design of an integrated NTR “core” stage providing both propulsion and power generation. The core stage uses three small (~15 klbf) bimodal NTR engines providing up to 50 kWe of electrical power, a portion of which (~15 kWe) is used to support an active refrigeration system for “zero-boiloff,” long term storage of LH<sub>2</sub> propellant. The bimodal stage uses a Brayton power conversion system enclosed within the vehicle’s conical thrust structure which also provides support for a common heat rejection radiator system. The incorporation of power generation and refrigeration systems results in a smaller, higher performance NTR stage with multiple burn, propulsive capture and reuse features. The use of multiple small engines also provides an “engine out” capability for the vehicle and should aid in the design of

“contained” ground facilities for rigorous engine testing that are both cost-effective and meet current environmental regulations.

A simpler, lower cost transportation system requiring fewer major elements and providing greater mission capability are a few of the major benefits of the bimodal NTR option. Table 18 compares and summarizes the number of mission elements and the ETO requirements for the DRM, “modified” DRM and “all BNTR” options examined in this paper. The DRM uses NTR propulsion for TMI, a large 30 kWe PVA for in space power, a heavy, common aerobrake/descent shell for MOC and reentry, a “SP-100” type nuclear reactor for surface power, LOX/CH<sub>4</sub> engines for TEI and an ECRV for Earth return—a total of 6 mission elements. The introduction of the BNTR in the “modified” DRM cuts this number in half (lowering DDT&E and recurring costs) while increasing the available power to payloads in transit and in Mars orbit to 50 kWe. The use of standardized modular components in the bimodal

**Table 18. Comparison of DRM, “Modified” DRM, and “All BNTR” Mars Mission Options**

Mission Elements and ETO Requirements	DRM	“Modified” DRM (BNTR)	“All NTR” (BNTR)	“All NTR” (BNTR) with “TransHab”	“All NTR” (BNTR) with “TransHab” and LANTR	ALT. ARCH. “All BNTR” with “TransHab”
TMI	NTR	BNTR *	BNTR	BNTR	BLANTR **	BNTR
In-Space Power	PVA (30 kWe)	BNTR (50 kWe)	BNTR (50 kWe)	BNTR (50 kWe)	BLANTR (50 kWe)	BNTR (50 kWe)
MOCS	AB *	AB & BNTR	BNTR	BNTR	BLANTR	BNTR
Mars Orbit Power	PVA (30 kWe)	BNTR (50 kWe)	BNTR (3 x 50 kWe)	BNTR (3 x 50 kWe)	BLANTR (3 x 50 kWe)	BNTR (3 x 50 kWe)
Mars Reentry System	Common AB/AS **	Common AB/AS	AS	AS	AS	AS
Surface Power	Nuc. Rx. (Brayton)	Common Rx. (Brayton)	Common Rx. (Brayton)	Common Rx. (Brayton)	Common Rx. (Brayton)	Common Rx. (Brayton)
TEI	LOX/CH <sub>4</sub>	BNTR	BNTR	BNTR	BLANTR	BNTR
EOC	ECRV †	ECRV	ECRV	ECRV & BNTR	ECRV	ECRV
Total # Major Systems	6	3	3	3	4	3
# Magnum Launches [Required lift (t)]	6 [80]	6 [80]	6 [88]	6 [85]	6 [83]	6 [80]
IMLEO (t)	~ 422	~ 396	~453	~ 461	~ 478 - 491	~ 421

\* BNTR: “Bimodal” NTR with Brayton Power Conversion/ \*\* BLANTR: BNTR with “LOX Afterburner” Nozzle

\* Aerobrake/ \*\* Aerodescent shell/ † ECRV: Earth Crew Return Vehicle

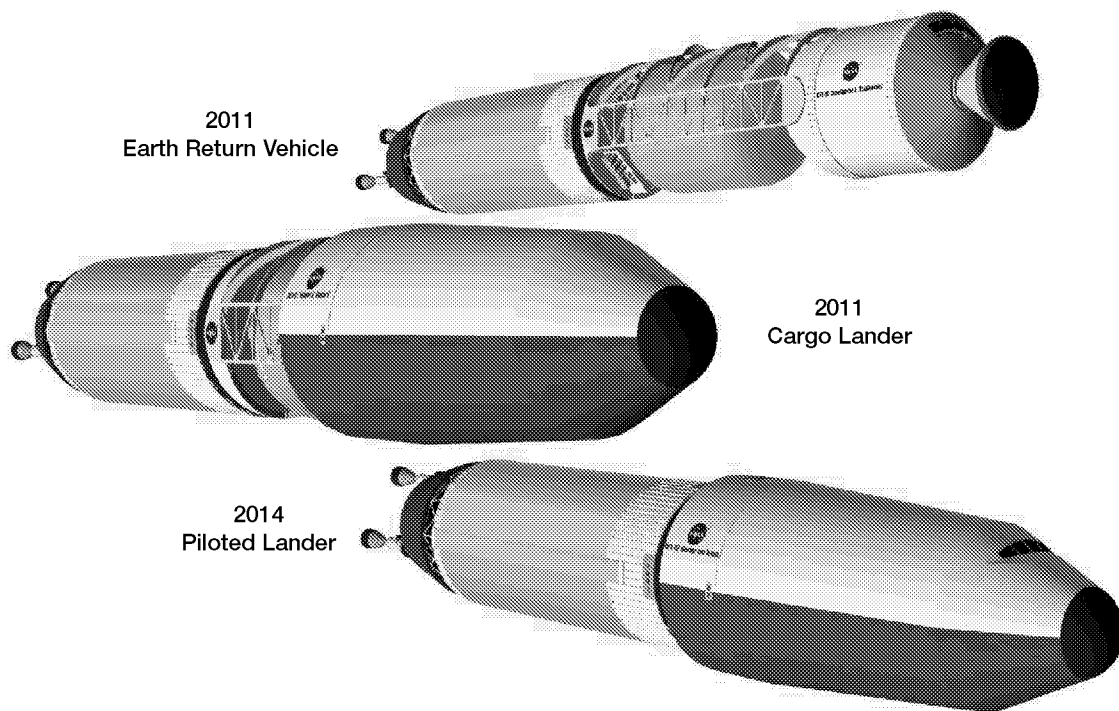

Figure 33.—Family of Bimodal NTR Transfer Vehicles Using "Modular" Components.

transfer vehicles (shown in Figure 33) and “common” gas-cooled reactor technology for both the bimodal engines and surface power reactor system helps reduce costs further. With its integrated power system, the bimodal core stage also simplifies space operations and lowers mission risk by eliminating the operational complexities of multiple PVA “deployment / retraction” cycles (e.g., prior to and after TMI, aerobraking and TEI maneuvers).

With propulsive capture at Mars, the power available in Mars orbit grows to 150 kWe per mission—five times that of the DRM. The more complex, higher risk aerobraking and capture maneuver is also replaced by a simpler atmospheric reentry using a “standardized,” lower mass “aerodescent” shell. The introduction of TransHab and LANTR affords further mission flexibility and downstream growth capability. The BNTR / TransHab combination provides options for reusing the ERV and shortening its mission duration by having the crew travel to and from Mars on the same bimodal transfer vehicle. The addition of LANTR engines enhances the performance of “volume-

limited” vehicles by increasing their bulk propellant density. Using bimodal LANTR and TransHab, Phobos rendezvous and landing options can be added to the current DRM.

If water is discovered on Phobos and its extraction for return propellant proves feasible, then Phobos could become an important staging point for the future exploration and development of Mars. A Phobos station and propellant depot would provide reusable LANTR-powered Mars transfer vehicles with their return propellant allowing them to shorten trip times or transport more high value cargo to Mars instead of bulk propellant. Reusable biconic-shaped LANTR-powered ascent / descent vehicles, operating from specially prepared sites on Mars, would ferry modular payload elements to and from the surface. Should Phobos be dry, they would also resupply orbiting transfer vehicles with propellants needed to reach refueling depots in the asteroid belt (see Figure 34). From there, the LANTR-powered transfer vehicles could continue on to the “water rich” moons of the Jovian system, providing a reliable foundation for the development and eventual human settlement of the Solar System.

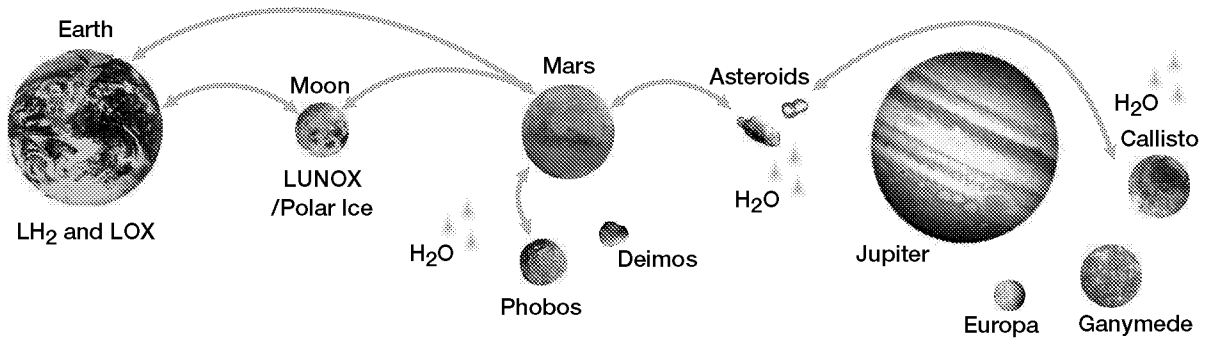

Figure 34.—Human Expansion Possibilities with LANTR Transfer Vehicles.

## REFERENCES

1. The Space Science Enterprise Strategic Plan—Origin, Evolution and Destiny of the Cosmos and Life, National Aeronautics and Space Administration (November 1997).
2. Beyond Earth's Boundaries - Human Exploration of the Solar System in the 21st Century, Office of Exploration Annual Report to the Administrator, National Aeronautics and Space Administration (1988).
3. S.K. Borowski, "Impact of Solid Core Nuclear Thermal Rocket (SC/NTR) Propulsion on Human Expeditions to Phobos / Mars," in Exploration Studies Technical Report—FY 1988 Status, Office of Exploration, NASA Technical Memorandum 4075, (December 1988), pp. 5–11 to 5–17.
4. A. Cohen, et al., Report of the 90-Day Study on Human Exploration of the Moon and Mars, National Aeronautics and Space Administration (November 1989).
5. S.K. Borowski, "An Evolutionary Lunar-to- Mars Space Transportation System Using Modular NTR / Stage Components," AIAA-91-3573, American Institute of Aeronautics and Astronautics (Jan. 1991).
6. America at the Threshold - America's Space Exploration Initiative, Report of the Synthesis Group, Available from the Superintendent of Documents, U. S. Government Printing Office, Washington, DC 20402 (June 1991).
7. J.K. Soldner and B.K. Joosten, "Mars Trajectory Options for the Space Exploration Initiative," AAS-91-438, ASS/AIAA Astrodynamics Specialist Conference (Aug. 1991).
8. B.K. Joosten, B.G. Drake, D.B. Weaver and J.K. Soldner, "Mission Design Strategies for the Human Exploration of Mars," IAF-91-336, 42nd Congress of the International Astronautical Federation (Oct. 1991).
9. R.M. Zubrin, D. Baker, and O. Gwynne, "Mars Direct: A Simple, Robust, and Cost-Effective Architecture for the Space Exploration Initiative," AIAA-91-0326, American Institute of Aeronautics and Astronautics (Jan. 1991).
10. S.K. Borowski, et al., "Nuclear Thermal Rocket/ Vehicle Design Options for Future NASA Missions to the Moon and Mars," AIAA-93-4170, American Institute of Aeronautics and Astronautics (Sept. 1993) and NASA Technical Memorandum 107071 (Sept. 1995).
11. Human Exploration of Mars: The Reference Mission of the NASA Mars Exploration Study Team, S. J. Hoffman and D. I. Kaplan, eds., NASA Special Publication 6107 (July 1997).
12. Reference Mission Version 3.0 Addendum to the Human Exploration of Mars: The Reference Mission of the NASA Mars Exploration Study Team, B.G. Drake, ed., Exploration Office Document EX13-98-036 (June 1998).

13. D.R. Koeing, "Experience Gained from the Space Nuclear Rocket Program (Rover)," LA-10062-H, Los Alamos National Laboratory (May 1986).
14. J.S. Clark, S.K. Borowski, R.J. Sefcik and T.J. Miller, "A Comparison of Technology Development Costs and Schedule for Nuclear Thermal Rockets for Missions to Mars," AIAA-93-2263, American Institute of Aeronautics and Astronautics (June 1993).
15. J.S. Clark, M.C. McIlwain, V. Smetanikov, E.K. D'Yakov, and V.A. Pavshook, "US/CIS Eye Joint Nuclear Rocket Venture," Aerospace America, Vol. 31, (July 1993).
16. D.W. Culver, et al., "Development of Life Prediction Capabilities for Liquid Propellant Rocket Engines," Task No. 8 (NTRE Extended Life Feasibility Assessment), Aerojet Propulsion Division Final Reports under NASA Contract NAS3-25883 (Oct. 1992 and July 1993).
17. D.W. Culver, V. Kolganov, and R. Rochow, "Low Thrust, Deep Throttling, US / CIS Integrated NTRE," 11th Symposium on Space Nuclear Power Systems, Albuquerque, New Mexico, (January 9-13, 1994).
18. S.K. Borowski, et al., "A Revolutionary Lunar Space Transportation System Architecture Using Extraterrestrial LOX-Augmented NTR Propulsion," AIAA-94-3343, American Institute of Aeronautics and Astronautics (June 1994) and NASA Technical Memorandum 106726 (August 1994).
19. S.K. Borowski, D.W. Culver and M.J. Bulman, "Human Exploration and Settlement of the Moon Using LUNOX-Augmented NTR Propulsion," 12th Symposium on Space Nuclear Power and Propulsion Systems, Albuquerque, New Mexico, (January 8-12, 1995) and NASA Technical Memorandum 107093 (October 1995).
20. D.W. Plachta, personal communications, NASA Lewis Research Center (1998).
21. R.H. Knoll, R.J. Stochl, and R. Sanabria, "A Review of Candidate Multilayer Insulation Systems for Potential Use on Wet-Launched LH<sub>2</sub> Tankage for the Space Exploration Initiative Lunar Mission," AIAA-91-2176, American Institute of Aeronautics and Astronautics (June 1991).
22. R.M. Zubrin, "The Use of Low Power Dual Mode Nuclear Thermal Rocket Engines to Support Space Exploration Missions," AIAA-91-3406, American Institute of Aeronautics and Astronautics (Sept. 1991).
23. M.L. Stancati, personal communications, Science Applications International Corporation (1998).
24. M.L. Stancati and J.T. Collins, "Mission Design Considerations for Nuclear Risk Mitigation," Proc. Nuclear Propulsion Technical Interchange Meeting, R.R. Corban, ed., NASA Conference Publication 10116, October 20-23, 1992, Vol.1, pp. 358-365.
25. B. O'Leary, "Rationales for Early Human Missions to Phobos and Deimos," in Lunar Bases and Space Activities of the 21st Century, Lunar and Planetary Institute, Houston, 1985, pp. 801-808.
26. P. Moore, G. Hunt, I. Nicolson, and P. Cattermole, The Atlas of the Solar System, Crescent Books, New York, 1990, pp. 240-241.



## APPENDIX

**Table A-1. Earth Return Vehicle Payload Mass (kg)**

Habitat Element	<u>26581</u>
Life Support System	4661
Crew Accom. + Consumables	12058
Health Care	0
EVA equipment	243
Comm/info Management	320
30 kW PVA power system	3249
Thermal Control system	550
Structure	5500
Science equipment	600
Spares	1924
<b>Total Cargo Mass</b>	<b>29105</b>
TEI stage dry mass	4806
Propellant mass	28866
Earth return RCS propellant	1115
Aerobrake	10180
<b>Tota Pay oad Mass</b>	<b>74072</b>

**Table A-2. Cargo Lander Payload Mass (kg)**

Earth Entry/Mars Ascent Capsule	4829
Ascent Stage Dry Mass	4069
ISRU plant	3941
Hydrogen feedstock	5420
PVA keep-alive power system	825
160 kW nuclear power plant	11425
1.0 km power cables, PMAD	837
Communication system	320
Pressurized Rover	0
Inflatable Laboratory Module	3100
15 kWe DIPS cart	1500
Unpressurized Rover	550
3 teleoperable science rovers	1500
Water storage tank	150
Science equipment	1770
<b>Total Cargo Mass</b>	<b>40236</b>
Vehicle structure	3186
Terminal propulsion system	1018
<b>Total Landed Mass</b>	<b>44440</b>
Propellant	10985
Forward aeroshell	9918
Parachutes and mechanisms	700
<b>Total Payload Mass</b>	<b>66043</b>

**Table A-3. Piloted Hab Lander Payload Mass (kg)**

Habitat element 2	<u>28505</u>
Life Support System	4661
Health Care	0
Crew Accomodations	12058
EVA equipment	243
Comm/info management	320
Power	3249
Thermal	550
Structure	5500
Science	0
Spares	1924
Crew	500
3 kW PVA keep-alive power	0
Unpressurized rover	550
EVA consumables	446
EVA suits	940
<b>Total Cargo Mass</b>	<b>30941</b>
Vehicle structure	3186
Terminal propulsion system	1018
<b>Total Landed Mass</b>	<b>35145</b>
Propellant	11381
Forward aeroshell	13580
Parachutes and mechanisms	700
<b>Total Payload Mass</b>	<b>60806</b>

**Table A-4. "Three Mission" IMLEO Summary for "All BNTR" Option  
 ("2 - Perigee Burn" Earth Departure Scenario / Transit Times: 220 (OB) & 180 (IB) Days)  
 (IMLEO ≤ 178 t / 2-88 t Magnum/Shuttle C HLLVs)**

Payload/Vehicle Propulsion/Isp	Element Masses (t)	2011 Cargo Lander Mission	2011 ERV Mission	2014 Piloted Lander Mission
Earth Return Vehicle Payload	Crew Hab Module		18.15	
	Spare ECRV			
	Contingency Consumables		7.31	
Ascent Stage LOX/CH <sub>4</sub> Isp = 379 s (O/F = 3.5:1)	Crew (6) & Suits			1.44
	MAV Crew Cab/ECRV	4.83		
	Ascent Stage	4.06		
	Propellant*	38.40		
Descent Stage LOX/ CH <sub>4</sub> Isp = 379 s (O/F = 3.5:1)	Surface Payload	31.34		26.54
	Descent Stage	4.20		4.20
	Aerodescent Shell <sup>†</sup>	8.23		7.94
	Parachutes	0.70		0.70
	Propellant**	8.91		7.92
Total Payload Mass		62.27	25.46	48.74
Common NTR Vehicles w/ Modular Components CIS w/ LH <sub>2</sub> Isp = 940 - 955 s	CIS Engines (#)	7.67(3)	7.67(3)	7.67(3)
	F(klbf) per engine/Isp(s)	14.76/955	15/940	14.76/955
	Radiation Shields (#)		3.24(3)	3.24(3)
	"In-Line" TMI LH <sub>2</sub> Tank & Structure	8.25	8.52	8.25
	TMI "Core" Stage Tank & Structure	11.77		11.77
	TMI/MOC/TEI "Core" Stage Tank & Structure		11.77	
	Brayton Power System (@ 50 kWe)	1.55	1.55	1.55
	LH <sub>2</sub> Refrigeration System***	0.60	0.34	0.60
	Avionics & Aux. Power	1.69	1.69	1.69
	Propellant****	68.35	62.35	77.54
RCS NTO/ MMH Isp = 320 s	Propulsion & Tankage	0.52	0.55	0.52
	Propellant	1.62	2.10	1.55
Total NTR Vehicle Mass		102.02	99.78	114.38
Total IMLEO		164.29	125.24	163.12

\* Produced at Mars using "in-situ" resources

\*\* Assumes parachutes and 632 m/s descent ΔV

\*\*\* Cooling capacity of "core" / "in-line" tanks @ ~75/46 W<sub>t</sub>, respectively

\*\*\*\* Contains boiloff, cooldown, "tank trapped" residual and disposal LH<sub>2</sub> also

† Using ARC Triconic aerobrake mass estimation formula with V<sub>e</sub>=4.5 km/s

**Table A-5. “Three Mission” IMLEO Summary for “Alternative Mission Profile”  
 (“Single Burn” Earth Departure Scenario/ Transit times: 210 (OB) & 180 (IB) days)  
 (IMLEO ≤ 160 t/ 2-80 t Magnum/Shuttle C HLLVs)**

Payload/Vehicle Propulsion/Isp	Element Masses (t)	2011 Cargo Lander	2011 “Unpiloted” Hab Lander	2014 Piloted Mission
Earth-Mars Transit Vehicle Payload	“TransHab” Module			14.96
	Crew (6) & Suits			1.44
	Extra Consumables			0.40
	Contingency Consumables			6.69
Ascent Stage LOX/CH <sub>4</sub> Isp = 379 s (O/F = 3.5:1)	MAV Crew Cab/ECRV	4.83		
	Ascent Stage	4.10		
	Propellant*	38.40		
Descent Stage LOX/ CH <sub>4</sub> Isp = 379 s (O/F = 3.5:1)	Surface Payload	24.42	25.37	
	Descent Stage	4.10	4.10	
	Aerodescent Shell <sup>†</sup>	8.05	7.90	
	Parachutes	0.70	0.70	
	Propellant**	7.53	7.76	
	Total Payload Mass	53.73	45.82	23.49
Common NTR Vehicles  w/ Modular Components  LH <sub>2</sub> NTR Isp = 955 s	CIS Engines (#)	7.67(3)	7.67(3)	7.67(3)
	F(klbf) per engine/Isp (s)	14.76/955	14.76/955	14.76/955
	Radiation Shields (#)			3.24(3)
	“In-Line” TMI LH <sub>2</sub> Tank & Structure	4.90	4.90	8.52
	TMI “Core” Stage Tank & Structure	11.77	11.77	
	TMI/MOC/TEI “Core” Stage Tank & Structure			11.77
	Brayton Power System (@ 50 kWe)	1.55	1.55	1.55
	LH <sub>2</sub> Refrigeration System***	0.55	0.34	0.34
	Avionics & Aux. Power	1.69	1.69	1.69
	LH <sub>2</sub> Propellant****	64.34	57.31	78.71
RCS NTO/ MMH Isp = 320 s	Propulsion & Tankage	0.51	0.50	0.55
	Propellant	1.44	1.30	2.11
	Total NTR Vehicle Mass	94.42	87.03	116.15
	Total IMLEO	148.15	132.85	139.64

\* Produced at Mars using “in-situ” resources

\*\* Assumes parachutes and 632 m/s descent ΔV

\*\*\* Cooling capacity of “core”/“in-line” tank @ ~75 and 27 W<sub>t</sub>, respectively

\*\*\*\* Contains boiloff, cooldown, “tank trapped” residual and disposal LH<sub>2</sub> also

† Using ARC Triconic aerobrake mass estimation formula with V<sub>o</sub> = 4.5 km/s

REPORT DOCUMENTATION PAGE			Form Approved OMB No. 0704-0188	
Public reporting burden for this collection of information is estimated to average 1 hour per response, including the time for reviewing instructions, searching existing data sources, gathering and maintaining the data needed, and completing and reviewing the collection of information. Send comments regarding this burden estimate or any other aspect of this collection of information, including suggestions for reducing this burden, to Washington Headquarters Services, Directorate for Information Operations and Reports, 1215 Jefferson Davis Highway, Suite 1204, Arlington, VA 22202-4302, and to the Office of Management and Budget, Paperwork Reduction Project (0704-0188), Washington, DC 20503.				
1. AGENCY USE ONLY (Leave blank)	2. REPORT DATE December 2002	3. REPORT TYPE AND DATES COVERED Technical Memorandum		
4. TITLE AND SUBTITLE Vehicle and Mission Design Options for the Human Exploration of Mars/Phobos Using "Bimodal" NTR and LANTR Propulsion			5. FUNDING NUMBERS WU-953-20-0C-00	
6. AUTHOR(S) Stanley K. Borowski, Leonard A. Dudzinski, and Melissa L. McGuire				
7. PERFORMING ORGANIZATION NAME(S) AND ADDRESS(ES) National Aeronautics and Space Administration John H. Glenn Research Center at Lewis Field Cleveland, Ohio 44135-3191			8. PERFORMING ORGANIZATION REPORT NUMBER E-11445-1	
9. SPONSORING/MONITORING AGENCY NAME(S) AND ADDRESS(ES) National Aeronautics and Space Administration Washington, DC 20546-0001			10. SPONSORING/MONITORING AGENCY REPORT NUMBER NASA TM-1998-208834-REV 1 AIAA-98-3883	
11. SUPPLEMENTARY NOTES Prepared for the 34th Joint Propulsion Conference cosponsored by the AIAA, ASME, SAE, and ASEE, Cleveland, Ohio, July 13-15, 1998. Stanley K. Borowski and Leonard A. Dudzinski, NASA Glenn Research Center; Melissa L. McGuire, Analex Corporation, 3001 Aerospace Parkway, Brook Park, Ohio 44142 (work funded under NAS3-27186). Responsible person, Stanley K. Borowski, organization code 6510, 216-977-7091.				
12a. DISTRIBUTION/AVAILABILITY STATEMENT Unclassified - Unlimited Subject Categories: 12, 15, 16, and 20 Available electronically at <a href="http://gltrs.grc.nasa.gov">http://gltrs.grc.nasa.gov</a> This publication is available from the NASA Center for AeroSpace Information, 301-621-0390.			12b. DISTRIBUTION CODE Distribution: Nonstandard	
13. ABSTRACT (Maximum 200 words) The nuclear thermal rocket (NTR) is one of the leading propulsion options for future human missions to Mars because of its high specific impulse (Isp-850-1000 s) capability and its attractive engine thrust-to-weight ratio (~3-10). To stay within the available mass and payload volume limits of a "Magnum" heavy lift vehicle, a high performance propulsion system is required for trans-Mars injection (TMI). An expendable TMI stage, powered by three 15 thousand pounds force (klbf) NTR engines is currently under consideration by NASA for its Design Reference Mission (DRM). However, because of the miniscule burnup of enriched uranium-235 during the Earth departure phase (~10 grams out of 33 kilograms in each NTR core), disposal of the TMI stage and its engines after a single use is a costly and inefficient use of this high performance stage. By reconfiguring the engines for both propulsive thrust and modest power generation (referred to as "bimodal" operation), a robust, multiple burn, "power-rich" stage with propulsive Mars capture and reuse capability is possible. A family of modular "bimodal" NTR (BNTR) vehicles are described which utilize a common "core" stage powered by three 15 klbf BNTRs that produce 50 kWe of total electrical power for crew life support, an active refrigeration / reliquification system for long term, zero-boiloff liquid hydrogen (LH <sub>2</sub> ) storage, and high data rate communications. An innovative, spine-like "saddle truss" design connects the core stage and payload element and is open underneath to allow supplemental "in-line" propellant tanks and contingency crew consumables to be easily jettisoned to improve vehicle performance. A "modified" DRM using BNTR transfer vehicles requires fewer transportation system elements, reduces IMLEO and mission risk, and simplifies space operations. By taking the next logical step—use of the BNTR for propulsive capture of all payload elements into Mars orbit—the power available in Mars orbit grows to 150 kWe compared to 30 kWe for the DRM. Propulsive capture also eliminates the complex, higher risk aerobraking and capture maneuver which is replaced by a simpler reentry using a standardized, lower mass "aerodescent" shell. The attractiveness of the "all BNTR" option is further increased by the substitution of the lightweight, inflatable "TransHab" module in place of the heavier, hard-shell hab module. Use of TransHab introduces the potential for propulsive recovery and reuse of the BNTR / Earth return vehicle (ERV). It also allows the crew to travel to and from Mars on the same BNTR transfer vehicle thereby cutting the duration of the ERV mission in half—from ~4.7 to 2.5 years. Finally, for difficult Mars options, such as Phobos rendezvous and sample return missions, volume (not mass) constraints limit the performance of the "all LH <sub>2</sub> " BNTR stage. The use of "LOX-augmented" NTR (LANTR) engines, operating at a modest oxygen-to-hydrogen mixture ratio (MR) of 0.5, helps to increase "bulk" propellant density and total thrust during the TMI burn. On all subsequent burns, the bimodal LANTR engines operate on LH <sub>2</sub> only (MR=0) to maximize vehicle performance while staying within the mass limits of two Magnum launches.				
14. SUBJECT TERMS Nuclear thermal rocket; NTR; "LOX-augmented" NTR; LANTR; Bimodal; In-situ resource utilization; High thrust; Nuclear propulsion; Mars; Phobos; Spacecraft			15. NUMBER OF PAGES 53	
			16. PRICE CODE	
17. SECURITY CLASSIFICATION OF REPORT Unclassified	18. SECURITY CLASSIFICATION OF THIS PAGE Unclassified	19. SECURITY CLASSIFICATION OF ABSTRACT Unclassified	20. LIMITATION OF ABSTRACT	



