

# Very High Dynamic Range and High-Sampling Rate VME Digitizing Board for Physics Experiments.

Dominique Breton, Eric Delagnes

CNRS/LAL Orsay, BP34, 91898 Orsay cedex  
breton@lal.in2p3.fr

CEA/DAPNIA, CE Saclay, 91191 Gif-sur-Yvette  
delagne@hep.saclay.cea.fr

## I. INTRODUCTION.

The trend in data acquisition systems for modern physics experiments is to digitize signals closer and closer to the detector. It allows more flexibility for online or offline treatments and it is particularly useful in the prototyping or early phases of the experiments. Commercial digitization boards have followed the evolution of ADC technologies and are today limited to sampling frequencies of 200 MHz for 10 to 12 bits of resolution. ADC chips with higher performances have been developed, mainly for military applications. But they are expensive, difficult to purchase and their huge power consumption makes them unusable for multi-channel systems. Yet, there are important needs for digitization systems with good resolution and sampling frequency higher than one GHz. In association with fast detectors, they can be used for timing, pulse shape discrimination and charge measurement even in a high rate or high background environment. The MATAQVME board described here has been developed especially for this purpose. It is built around the MATAQ chip which will be described below.

## II. DESCRIPTION OF THE MATAQ CHIP.

The MATAQ chip is a circular buffer based on a new and innovative matrix structure. The latter was patented in 2001. It makes use, as some former chips [1] [2], of an array of switched capacitors associated with a Delay Line Loop. But, thanks to its new matrix structure, its memory depth has been extended to 2500 samples. Its dynamic range is also improved thanks to the experience acquired in the design of the structures and to the techniques originally developed for the ATLAS calorimeter analog memory [3].

The main innovation is that there is a unique pulse pointer traveling inside the matrix during the acquisition and providing both the beginning and the end of the acquisition phase for every single sampling cell. Moreover, the time precision achieved is impressive thanks to the short individual delay locked loops (DLL) present in every column of the structure which offer a very low jitter. The 2GHz sampling frequency is achieved with a clock frequency of only 100MHz, this thanks to the virtual frequency multiplication of the DLL.

An example of the corresponding principle is described on fig1. A pulse propagates along a chain of 20 individual 1ns

delays. All of them can be finely tuned by an analog voltage command. Their respective outputs are connected to analog sampling cells. At the output of the last delay, the phase of the sampling edge is compared to the phase of the input pulse delayed by 20ns. The phase comparator then produces an analog voltage which is used to servo-control the chain of delays.

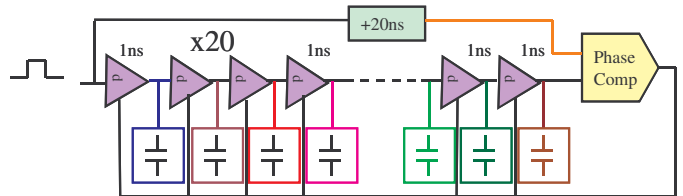

Fig. 1: Principle of the DLL.

The same principle is used in every column of the matrix as shown on fig 2. The DLL input pulses actually correspond to the successive outputs of a main shift register clocked by the 50MHz clock reshaped in dedicated blocks. The 20ns precise delay is provided by a second shift register (called "reference") where the pulse is delayed by one clock period compared to the first register. During every clock period, the pointer propagates inside a new column, thus covering the full matrix after a while. After having reached the end of the last column, it comes back to the top of the first one.

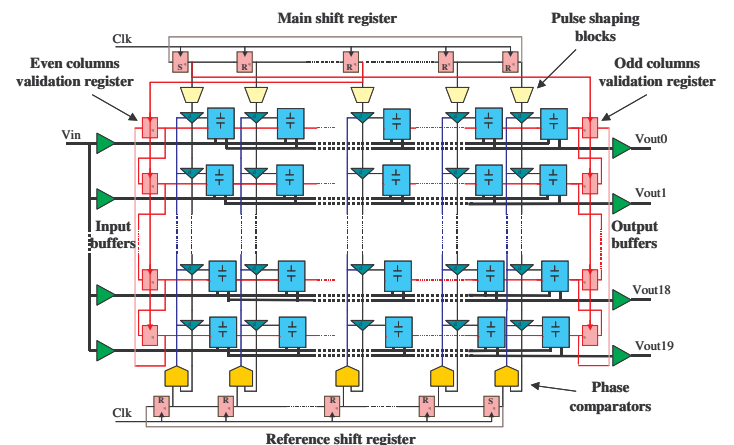

Fig. 2: the new patented structure.

The so-called validation registers can possibly be used to mask some chosen lines to reduce the acquisition frequency. To

ensure the absence of crosstalk between the lines, an input buffer is located on each of them. Thus no effect of a switch sampling the signal on a given line can be seen on the next line which will get sampled right after. Moreover, the total power dissipation is lower than with a single global input buffer.

The chip dynamic range is  $\pm 2V$ . In this type of design, the most difficult is to optimize the input bandwidth of the cell, including the input amplifier. Here, the input buffer bandwidth thus the chip power consumption are actually programmable by software: 1W for 300MHz, 1/2W for 250MHz, 1/4W for 200MHz, below 100mW in stand-by.

One specificity: there is one constant pedestal value per line (20 in total), which has to be calibrated once and subtracted by software after data readout. It remains valid for months.

Acquisition is stopped upon reception of a stop signal. The latter derives from an asynchronous trigger signal which will be precisely dated inside the chip with a precision of 25ps RMS. This will eventually permit the perfect synchronization of all the channels on a board. Then analog data can be read out and converted into digital over 12 bits. This can be done either from the first cell to the last, or from the column where acquisition was stopped, thus allowing a partial and selective readout of the memory.

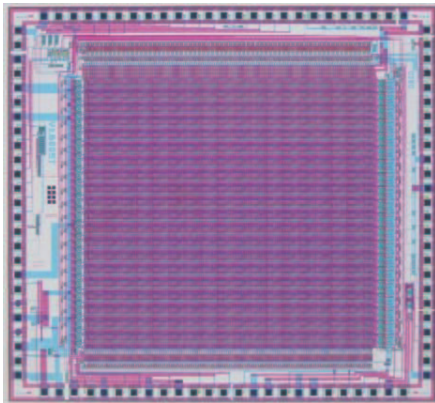

Fig. 3: the MATAcq chip layout.

The MATAcq chip is a full custom circuit designed by the authors. It is fabricated in the old, but inexpensive, AMS pure CMOS 0.8  $\mu m$ . The latter being on its way to obsolescence at the end of 2004, a 0.35 $\mu m$  version is currently under design.

### III. DESCRIPTION OF THE MATAcqVME BOARD.

#### A. MATAcqVME board overview.

The MATAcqVME board (see fig 5 & 6), based on the custom MATAcq IC, is suited for acquisition of fast analog signals. It performs the coding of 4 or 8 (depending on the version) analog channels of bandwidth up to 300MHz over a 12-bit dynamic range, at a sampling frequency ( $F_e$ ) reaching up

to 2GHz and over a depth of 2520 usable points. This board, in the mechanical format VME double Europe (triple Europe for the 8-channel version), is compatible with several standards of acquisition (VME A32/D32, A24/D16, GPIB and SPECS [6]).

As shown on fig 4, the acquisition is realized in three phases:

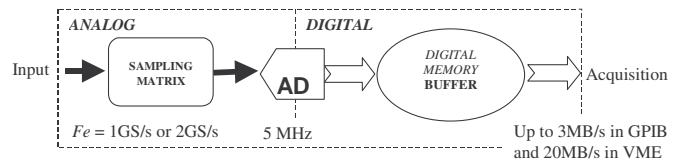

Fig. 4: Data flow in the MATAcqVME board.

- Acquisition: the analog signal is continuously sampled at the sampling frequency  $F_e$  in the MATAcq circular analog memory. The arrival of a trigger signal initiates the stopping phase of the sampling. At the end of this phase, the state of the memory is set: it then contains the last 2560 points sampled (of which 2520 are valid).

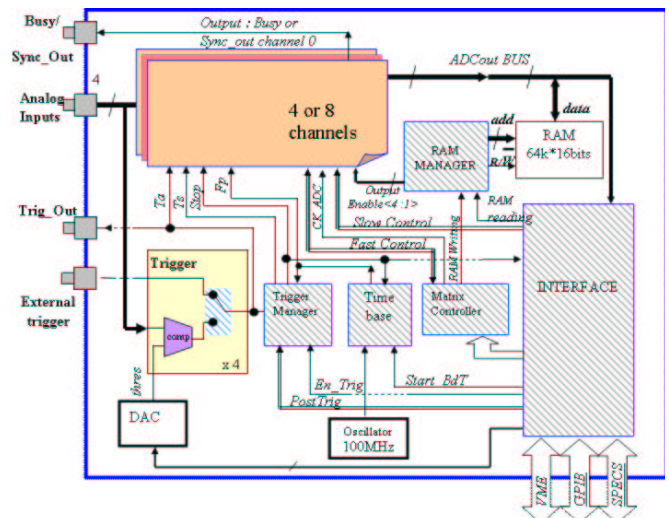

Fig. 5: Synopsis of the MATAcqVME board.

- Digitization and storage: upon reception of the order to stop the acquisition, the samples stored under analog form in the MATAcq chips are read out rapidly (650 $\mu s$  for 4 full channels) and coded into digital data over 12 bits, then stored in the event RAM. The acquisition is then informed of the end of the coding phase by the sending of an interruption (it may also scan a flag within an internal register).

- Reading: the memory buffer can then be read out by the acquisition system. For an acquisition system of VME A24-D16 standard, the latter operation lasts a few ms for the full readout of a 4-channel board, which permits attaining an acquisition frequency of a few hundred Hz for the readout of 2500 points per channel. Using the fastest readout mode, a rate of 500 acquisitions of all the cells over the 4 channels is reachable. A special readout mode, allowing the user to transfer

selectively only a part of the memory, permits increasing even more the acquisition rate.

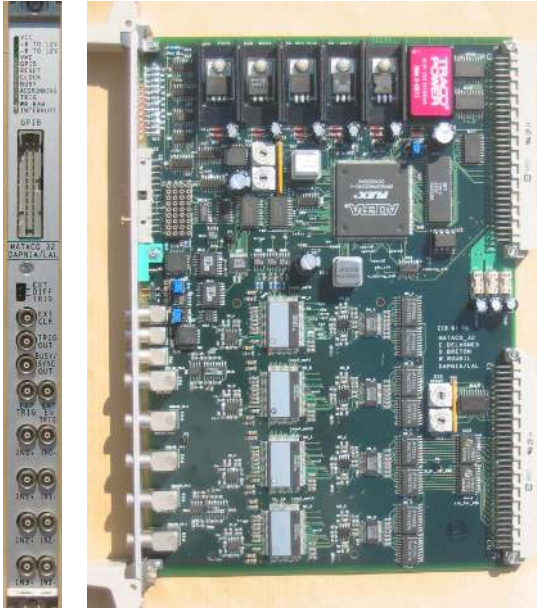

Fig. 6: the 4-channel MATAQVME board.

### B. MATAQVME board triggering.

Several modes of triggering are available on this board (see fig 7). Each analog input is sent to a comparator receiving a common DAC programmable threshold. Each output of these comparators or any logical-OR combination of them can be used for triggering the board. It can also be done by an external input, compatible with both ECL or NIM levels. Several MATAQVME boards can be synchronized by using a common external trigger and/or thanks to the “Trig\_Out” output and “Ext\_Trig” input available on each board.

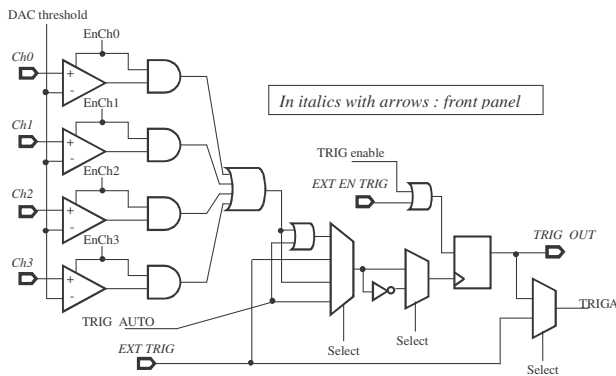

Fig. 7: the trigger selection tree.

The position of the 2500-point acquisition window relatively to the trigger is programmable over a 650  $\mu$ s range. An on-chip interpolation system dates the trigger with a 25ps RMS precision, much better than the sampling period thus allowing a

good synchronization between channels or boards, and consequently the adequate use of this board in time measurement experiments. Moreover, it also permits performing acquisitions in equivalent time like with an oscilloscope.

### C. MATAQVME board performances.

Fig 8 shows the noise result of a one-shot acquisition performed over 160 channels located in the same crate. The left plot displays the raw acquired data with all the 2560-point channel data superimposed. The right plot displays the RMS distribution of the same event, thus showing a mean value of about 200 $\mu$ V RMS which combined with the 1V dynamic range confirms the SNR of 12 bits RMS.

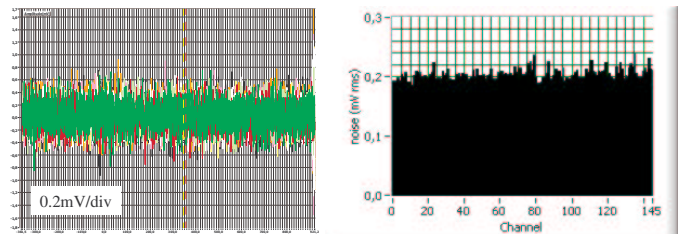

Fig. 8: noise results of a one-shot acquisition over 160 channels.

Fig 9 first displays the time alignment distribution of two different channels fed with the same signal. As shown, the alignment is very accurate with a RMS jitter per channel of only 23ps. The plot on the right shows the integral non-linearity of the board over the whole dynamic range (the units are arbitrary). The result is well within +/- 1 per mil, which is impressive for this type of board. The measurement was done on bipolar pulses with the ATLAS LARG calibration system.

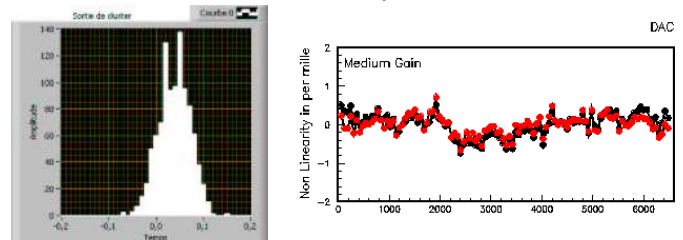

Fig. 9: inter-channel time alignment and non-linearity.

Fig 10 displays two different types of acquisitions.

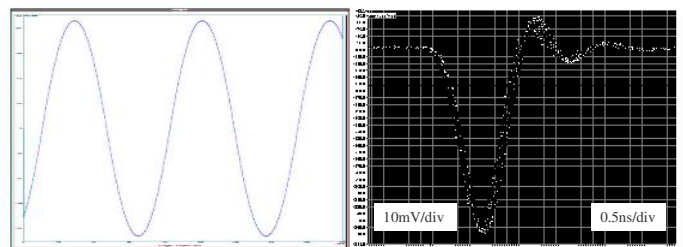

Fig. 10: real time and equivalent time acquisitions.

The first one on the left is a standard real time acquisition of a sine wave signal. One can appreciate how smooth the signal appears thanks to the 12-bit SNR. On the right, a repetitive 2ns FWHM pulse has been acquired in equivalent time. This mode is available thanks to the high level of precision of the trigger datation. The width of the track is due to the sum of three different jitters: the signal shape intrinsic jitter, the trigger chain jitter and the sampling jitter. As it can be seen on the falling edge of the pulse, the total jitter here is lower than 40ps RMS.

Another important feature of the board is its capacity to perform a FFT on a single acquisition thanks to its high SNR and very good linearity. Figure 11 shows the result of an FFT on a 10MHz sine wave. One can note that there is no harmonic distortion above -65dB on that plot.

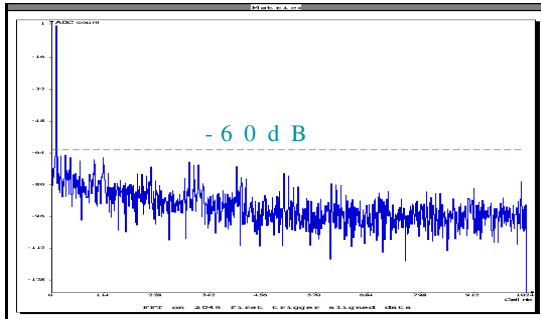

Fig. 11: FFT on a single sine wave acquisition.

The main characteristics and the performances measured on the board are summarized in table I.

TABLE I.

MAIN PERFORMANCES AND CHARACTERISTICS OF THE MATAQVME BOARD.

NAME	Quantity	Unit
Input impedance	50	Ohm
Dynamic Range	+/- 0.5	V
Digitization LSB	250	$\mu$ V
Noise	<200	$\mu$ V RMS
Analog Bandwidth	300	MHz
Harmonic distortion ( for 25MHz sinus input)	< -60	dB
Integral non linearity	<1	per mil
Differential Non linearity	<0.5	per mil
Sampling frequency	1 or 2	Gsample/s
Sampling jitter	<50	ps RMS

#### IV. EXAMPLES OF APPLICATIONS.

There are currently a lot of applications of the MATAQVME boards. Most of them are gathered within three main following fields:

- Timing measurement in very high-rate or noisy environments.
- Test benches for fast detector characterization.
- Pulse shape identification and measurement.

We'll now give an example in each of those fields.

##### A. The MATAQVME board in DEMIN.

Even if it is now used in a lot of other experiments, as CAST[4] since summer 2003, the MATAQVME board had

first been developed to perform the readout of the DEMIN neutron detector. The goal of this detector is to perform neutron time-of-flight spectrometry on inertial confinement fusion experiments (NIF and LMJ Facilities). DEMIN is a thin Micromegas detector associated with a neutron-to-charged particle conversion foil. It has been designed to offer a very good discrimination between neutrons and gammas. This intrinsic  $\gamma$ -ray insensitivity allows neutron measurements in large  $\gamma$  background. This detector delivers for each incoming neutron a 3ns FWHM pulse followed by a few tens ns long tail. As the expected rate is very high, the anode of the detector is stripped. Each strip signal is digitized during a 1.2 $\mu$ s window after the laser shot by a MATAQV channel, in order to extract the timing of the neutron impulsions. In May 2003, a first 40-channel setup was tested with the Omega Laser (LLE, Rochester). The record of a complete laser shot is given in fig 12. It shows the complexity of the signal.

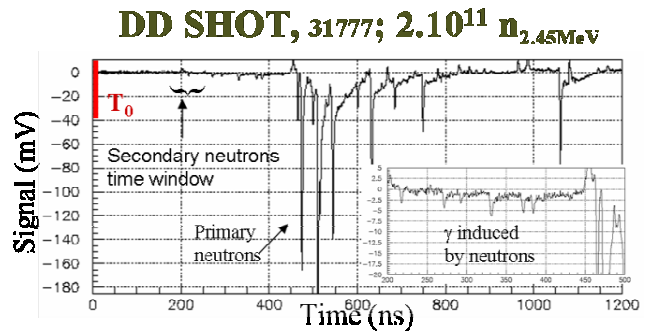

Fig. 12: DEMIN signal acquired with a MATAQVME board during May 2003 tests. T0 is corresponding to the laser shot time.

Figure 13 is a zoom on the high amplitude signal area and shows the ability for the board's user to perform neutron timing even in case of heavy pile-up.

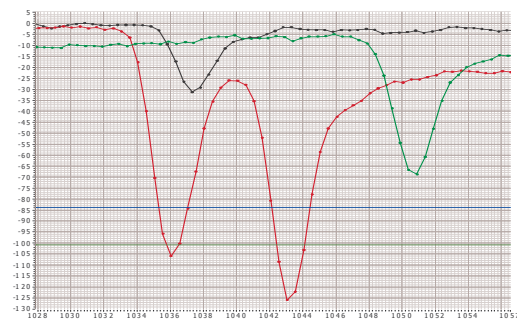

Fig. 13: zoom on three DEMIN signals acquired with a MATAQVME board (the scales are 2ns and 5mV/div).

Fig 14 shows the integration of 160 acquisition channels in a single 9U VME crate. The setup actually consists of 20 8-channel boards powered by a dedicated backplane in the P3 position. The same backplane is used to distribute the GPIB bus buffered in the board on the right side which is connected

through its front panel to the PC laptop. The interface type is USB and the acquisition software was written with LabView.



A 160-channel 2GS/s 12-bit digitizer in a single crate !

Fig. 14: the 160-channel crate used for DEMIN.

### B. A fine characterization test setup for PMTs.

The MATAQVME board is perfectly suited for the fine characterization of fast detectors. Usually, fast ADCs, QDCs or/and TDCs are used for this purpose. But even using all of them together doesn't make one able to get the same quality of information as getting the whole signal shape with a very fast sampling and high precision. Indeed, the shape, the amplitude, the timing, the surface of the signal can all be extracted from the data produced by the MATAQVME board, even within heavy pile-up.

A test bench dedicated to the fine characterization of different PMTs has been developed at IPN Orsay (contact: Bernard Genolini / genolini@ipno.in2p3.fr). It was formerly based upon the types of digitizers quoted above. Fine and numerous measurements had been performed with the latter and this gives a very good reference for the comparison with the new setup now based upon a single MATAQVME board.

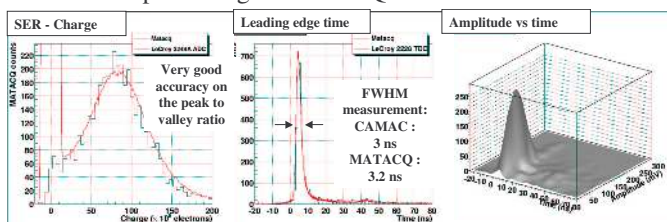

Fig. 15: the PMT characterization results.

Fig 15 shows the different result plots summarizing the performance comparison. One can appreciate there how well the MATAQVME board not only covers all the functionalities (charge and time measurements) of the different high performance equipment formerly operated, but also permits performing a 3D amplitude vs time histogram of the single photo-electron responses (main and late pulses), which was impossible before with such an accuracy. This kind of plot is

one of the most important ones for the characterization of the first stages of a PMT.

### C. The production test bench of the ATLAS LARG 128-channel calibration board.

This board (see Fig 16) is in charge of delivering the very precise LARG-like pulses which will be used to calibrate the LARG calorimeter electronics of ATLAS. It offers a steep negative edge followed by a 400ns long rising decay. The precision is as high as 16 bits. To validate the boards, the pulses are not measured directly, but at the output of a preamp-plus-shaper chain identical to that present on the calorimeter Front-End board. A plot of the first lobe of this signal is shown below.

About 300 of those calibration cards will be produced soon. In order to perform the test of that series, it had first been envisaged to use a standard 40MHz 12-bit ADC board. But the little dispersion in the peak time of the signal forced people to also make use of an oscilloscope to look at the shape and the timing to inter-calibrate the channels. Thus the arrival of the MATAQVME board offered a unique and perfectly adequate solution for all the measurements. Indeed, the shape can now be measured fast and precisely as shown of fig 16, and the high time precision moreover permits now measuring the board pulses' jitter.

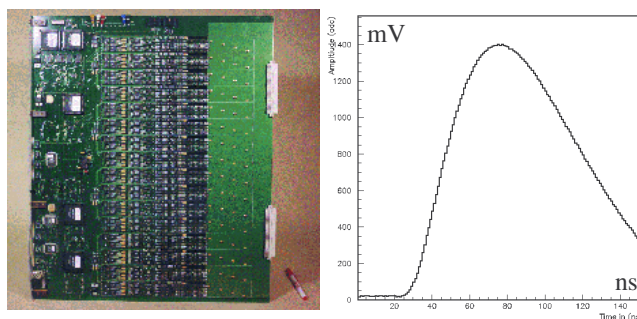

Fig. 16: the ATLAS LARG 128-channel calibration board and the characterization signal measured with MATAQVME.

## REFERENCES

- [1] "A multi-gigahertz analog transient recorder integrated circuit", S.Kleinfelder, University of California, Berkeley, thesis, May 1992.
- [2] "Application Specific Integrated Circuits For Antares Offshore Front-End Electronics", D. Lachartre, F. Feinstein, Proceeding On New Developments In Photodetection (Nim) Beaune June 21-25, 1999 P 99-104.
- [3] "A 16 Bit-40 Mhz Readout System Based On Dual Port Analog Memories For LHC Experiments.", D. Breton, E. Delagnes et al., Proceedings Of The 2<sup>nd</sup> Workshop On Electronics For Lhc Experiments, Sept96, Balatonfüred (Hungary).
- [4] "A low Background Micromegas Detector for Axion Searches". S. Andriamonje, S. Aune, T. Dafni, E. Delagnes, G.K. Fanourakis, E. Ferrer Ribas, T. Gerialis, Y. Giomataris, K. Kousouris, T. Papaevangelou, K. Zachariadou. 10th Vienna Conference on Instrumentation, 2004, submitted to NIM .
- [5] "Experimental studies of a MICROMEAS neutron detector", S. Andriamonje et al. , Nucl. Instrum. Methods A 481 (2002) 36-45.
- [6] "Serial Protocol for the Experiment Control System of LHCb," LHCb 2001-144, July 2001, D. Breton and Ph. Cros,