

## VIRGO: a large interferometer for Gravitational Wave detection started its first scientific run

F.Acernese<sup>7,9</sup>, M.Alshourbagy<sup>15,16</sup>, P.Amico<sup>13,14</sup>, F.Antonucci<sup>19</sup>, S.Aoudia<sup>10</sup>, P.Astone<sup>19</sup>, S.Avino<sup>7,8</sup>, L.Baggio<sup>1</sup>, F.Barone<sup>7,9</sup>, L.Barsotti<sup>15,16</sup>, M. Barsuglia<sup>11</sup>, Th.S.Bauer<sup>21,22</sup>, S.Bigotta<sup>15,16</sup>, S.Birindelli<sup>15,16</sup>, M. Bizouard<sup>11</sup>, C.Boccaro<sup>12</sup>, F.Bondu<sup>10</sup>, L.Bosi<sup>13,14</sup>, S.Braccini<sup>15</sup>, C.Bradaschia<sup>15</sup>, A.Brillet<sup>10</sup>, V. Brisson<sup>11</sup>, D.Buskulic<sup>1</sup>, G.Cagnoli<sup>3</sup>, E.Calloni<sup>7,8</sup>, E.Campagna<sup>3,5</sup>, F. Cavalier<sup>11</sup>, R.Cavaliere<sup>2</sup>, G.Cella<sup>15</sup>, E.Cesarini<sup>3,4</sup>, E.Chassande-Mottin<sup>10</sup>, A.-C.Clapson<sup>11</sup>, F.Cleva<sup>10</sup>, E.Coccia<sup>23,24</sup>, C.Corda<sup>15,16</sup>, A.Corsi<sup>19</sup>, F.Cottone<sup>13,14</sup>, J.-P.Coulon<sup>10</sup>, E.Cuoco<sup>2</sup>, S.D'Antonio<sup>23,24</sup>, A.Dari<sup>13,14</sup>, V.Dattilo<sup>2</sup>, M. Davier<sup>11</sup>, R.De Rosa<sup>7,8</sup>, M.Del Prete<sup>17,16</sup>, L.Di Fiore<sup>7</sup>, A.Di Lieto<sup>15,16</sup>, A.Di Virgilio<sup>15</sup>, B.Dujardin<sup>10</sup>, M.Evans<sup>2</sup>, V.Fafone<sup>23,24</sup>, I.Ferrante<sup>15,16</sup>, F.Fidecaro<sup>15,16</sup>, I.Fiori<sup>2</sup>, R.Flaminio<sup>6</sup>, J.-D.Fournier<sup>10</sup>, S.Frasca<sup>19,20</sup>, F.Frasconi<sup>15,\*</sup>, L.Gammaitoni<sup>13,14</sup>, F.Garufi<sup>7,8</sup>, E.Genin<sup>2</sup>, A.Gennai<sup>15</sup>, A.Giazotto<sup>2,15</sup>, L.Giordano<sup>7,8</sup>, V.Granata<sup>1</sup>, C.Greverie<sup>10</sup>, D.Grosjean<sup>1</sup>, G.Guidi<sup>3,5</sup>, S.Hamdani<sup>2</sup>, S.Hebri<sup>2</sup>, H.Heitmann<sup>10</sup>, P. Hello<sup>11</sup>, D.Huet<sup>2</sup>, S. Kreckelbergh<sup>11</sup>, P.La Penna<sup>2</sup>, M.Laval<sup>10</sup>, N.Leroy<sup>11</sup>, N.Letendre<sup>1</sup>, B.Lopez<sup>2</sup>, M.Lorenzini<sup>3,4</sup>, V.Loriette<sup>12</sup>, G.Losurdo<sup>3</sup>, J.-M.Mackowski<sup>6</sup>, E.Majorana<sup>19</sup>, M.Mantovani<sup>17,16</sup>, F.Marchesoni<sup>13,14</sup>, F.Marion<sup>1</sup>, J.Marque<sup>2</sup>, F.Martelli<sup>3,5</sup>, A.Masserot<sup>1</sup>, F.Menzinger<sup>2</sup>, L.Milano<sup>7,8</sup>, Y.Minenkov<sup>23,24</sup>, C.Moins<sup>2</sup>, J.Moreau<sup>12</sup>, N.Morgado<sup>6</sup>, S.Mosca<sup>7,8</sup>, B.Mours<sup>1</sup>, C.N.Man<sup>10</sup>, I.Neri<sup>13,14</sup>, F.Nocera<sup>2</sup>, G.Pagliaroli<sup>23,24</sup>, C.Palomba<sup>19</sup>, F.Paoletti<sup>2,15</sup>, S.Pardi<sup>7,8</sup>, A.Pasqualetti<sup>2</sup>, R.Passaquetti<sup>15,16</sup>, D.Passuello<sup>15</sup>, F.Piergiovanni<sup>3,5</sup>, L.Pinard<sup>6</sup>, R.Poggiani<sup>15,16</sup>, M.Punturo<sup>13</sup>, P.Puppo<sup>19</sup>, P.Rapagnani<sup>19,20</sup>, T.Regimbau<sup>12</sup>, A.Remillieux<sup>6</sup>, F.Ricci<sup>19,20</sup>, I.Ricciardi<sup>7,8</sup>, A.Rocchi<sup>23,24</sup>, L.Rolland<sup>1</sup>, R.Romano<sup>7,9</sup>, P.Ruggi<sup>2</sup>, G.Russo<sup>7,8</sup>, S.Solimeno<sup>7,8</sup>, A.Spallicci<sup>10</sup>, M.Tarallo<sup>15,16</sup>, R.Terenzi<sup>23,24</sup>, A.Toncelli<sup>15,16</sup>, M.Tonelli<sup>15,16</sup>, E.Tournefier<sup>1</sup>, F.Travasso<sup>13,14</sup>, C.Tremola<sup>15,16</sup>, G.Vajente<sup>18,16</sup>, J.F.J. van der Brand<sup>21,22</sup>, S. van der Putten<sup>21,22</sup>, D.Verkindt<sup>1</sup>, F.Vetrano<sup>3,5</sup>, A.Vicerè<sup>3,5</sup>, J.-Y.Vinet<sup>10</sup>, H.Vocca<sup>13,14</sup>, M.Yvert<sup>1</sup>

<sup>1</sup>Laboratoire d'Annecy-le-Vieux de Physique des Particules (LAPP), IN2P3/CNRS, Université de Savoie, Annecy-le-Vieux, France

<sup>2</sup>European Gravitational Observatory (EGO), Cascina (Pi), Italia

<sup>3</sup>INFN, Sezione di Firenze, Sesto Fiorentino

<sup>4</sup>Università degli Studi di Firenze, Firenze

<sup>5</sup>Università degli Studi di Urbino "Carlo Bo", Urbino

<sup>6</sup>LMA, Villeurbanne, Lyon, France

<sup>7</sup>INFN, sezione di Napoli

<sup>8</sup>Università di Napoli "Federico II" Complesso Universitario di Monte S. Angelo

<sup>9</sup>Università di Salerno, Fisciano (Sa), Italia

<sup>10</sup>Departement Artemis -- Observatoire de la Cote d'Azur, BP 42209 06304 Nice, Cedex 4, France

<sup>11</sup>LAL, Univ Paris-Sud, IN2P3/CNRS, Orsay, France

<sup>12</sup>ESPCI, Paris, France

<sup>13</sup>INFN, Sezione di Perugia

<sup>14</sup>Università di Perugia, Perugia, Italia

<sup>15</sup>INFN, Sezione di Pisa

<sup>16</sup>Università di Pisa, Pisa, Italia

<sup>17</sup>Università di Siena, Siena, Italia

<sup>18</sup>Scuola Normale Superiore, Pisa, Italia

<sup>19</sup>INFN, Sezione di Roma

<sup>20</sup>Università "La Sapienza", Roma, Italia

<sup>21</sup>NIKHEF, NL-1009 DB Amsterdam, The Netherlands

<sup>22</sup>Vrije Universiteit, NL-1081 HV Amsterdam, The Netherlands

<sup>23</sup>INFN, Sezione di Roma Tor Vergata, Roma, Italia

<sup>24</sup>Università di Roma Tor Vergata, Roma, Italia

<sup>25</sup>Università dell'Aquila, L'Aquila, Italia

\* Paper presented at the conference by F. Frasconi

e-mail: [franco.frasconi@pi.infn.it](mailto:franco.frasconi@pi.infn.it)

**Abstract** The VIRGO interferometer is the largest ground based European gravitational wave detector operating at the EGO Laboratory in the Pisa (Italy) countryside. During the last commissioning period relevant progress have been done in approaching its design sensitivity all over the detection bandwidth. Thanks to the effort of the whole Collaboration a long scientific run has been done collecting data for more than 4 months in conjunction with the LIGO detectors. The results obtained from the detector point of view are: a very good stability and a duty-cycle as high as 81% in science mode. In this paper we present the status of the VIRGO interferometer giving an overview of the experimental apparatus together with its most relevant features.

## 1. Introduction

Nowadays gravitational waves search on Earth is based on broadband detectors able to explore a large fraction of the universe where astrophysical sources are expected to emit signals in the frequency range between a few Hz and a few kHz. The VIRGO interferometer is the largest European gravitational wave detector operating in Italy thanks to the starting effort of the Italian - French Collaboration financed by two founding agencies: the INFN for the Italian side and the CNRS for the French one. Together with similar detectors, like the three LIGO [1] and GEO [2] interferometers based on the same working principle, VIRGO will be a crucial node of a detector network able to perform detailed gravitational field studies. To this purpose the required high sensitivity to differential variation of the two perpendicular arms length of the order of  $10^{-18}$  m, is achievable by using a high power laser source together with the technique to store the light inside the interferometer arms. With the first choice the improvement of the fringe resolution reducing the shot noise is reachable while the light storage into the interferometer arms will increase the phase shift due to a passing gravitational wave. In addition, the detection of gravitational waves on the Earth by using a similar apparatus is related to its capability in isolating the real signals from fake ones. For this reason the optical components of an interferometer should be isolated by a suspension system which is able to reduce noise transmission to the mirror level.

The VIRGO detector consists of a recycled Michelson interferometer with two Fabry-Perot cavities accommodated along the 3 km arms [3]. A laser beam running forward and backward within two long pipes 1.2 m in diameter and the nine towers containing seismic isolation system for the optical components, represent the probe through which a very precise measurement of the optical path length variation along the arms is performed.

## 2. The VIRGO detector

The VIRGO interferometer is based on a beam generated by a 20 W high-power Nd:YVO<sub>4</sub> laser source locked to a 1 W solid state Nd:YAG master laser installed on an optical table (Laser Bench – LB) ground connected and installed within a clean-room laboratory with controlled temperature. As sketched in fig. 1 the beam is sent to a second optical bench (External Injection Bench – EIB) accommodated within the same laser laboratory, to be correctly aligned with respect to the interferometer reference frame before entering into the vacuum system. An optical window separates the laboratory environment from the large vacuum volume of the detector (about 7000 m<sup>3</sup>) maintained at a hydrogen partial pressure of  $10^{-7}$  mbar. The first mechanical element under vacuum with an octagonal shape is the Suspended Injection Bench (SIB in fig. 1) hung to a short suspension system conceived to suppress seismic noise transmission to the optical components level [4]. The design of this SIB has been recently revised including, among other sophisticated optical components, a Faraday Isolator system (FI) to reject the back-reflected light. The upper part of this bench is equipped with two flat mirrors optically contacted to a dihedron which form, together with a curved mirror suspended from a short suspension chain about 144 m far away, the Input Mode Cleaner (IMC) triangular cavity. The passage of the beam through this optical cavity is used to spatially filter the beam (selecting the TEM<sub>00</sub> mode) and for the laser frequency pre-stabilization. In the low frequency region, below 15 Hz, the IMC is stabilized by using a short (30 cm long) rigid reference cavity (RFC) bolted on the bottom part of the SIB.

The beam then enters the main interferometer consisting of a flat Power Recycling (PR) mirror, a Beam Splitter (BS) used to separate the incoming laser beam and two Fabry-Perot cavities each one formed by a flat input mirror (NI and WI) and an end curved one (NE and WE) installed within a vacuum tower 3 km far away. The nominal finesse of these two optical cavities, North and West side respectively oriented, is 50 and they are used to enhance the light path amplifying the beam phase change induced by the optical path length variation.

Since in standard working conditions the interferometer is locked on the dark fringe, all the light (apart some losses and the small amount transmitted through the terminal mirrors) sent by the injection system

into the interferometer is back-reflected. For this reason the high reflectivity of the PR mirror (95%) is used to recombine in coherent way this power and creating an additional cavity between the PR mirror and the Michelson interferometer. Thanks to this technique the power impinging onto the BS mirror is amplified by a factor about 35 (recycling factor) reducing the shot noise. All these six mirrors are suspended from a long mechanical isolation system called Superattenuator (SA) and conceived to suppress seismic noise transmission at the mirror level. The SA is the most original element of the entire experimental apparatus. It is a hybrid system combining the passive seismic attenuation performance of a second order mechanical filter chain based on a multi-stage pendulum working principle and an active feed-back control performance applied in the low frequency range (below 4 Hz) where all internal mode of the mechanical structures are confined. This is possible thanks to a three legs soft elastic structure used as a pre-isolation stage designed on the working principle of an Inverted Pendulum (IP). The SA has been built to provide the required passive filtering performance of seismic noise starting from a few Hz in all degrees of freedom. An upper limit of the system has been measured during the commissioning phase obtaining an attenuation factor of  $10^{15}$  at 10 Hz [5].

The top stage of IP is the suspension point of the six filters chain and the inertial platform equipped with sensors and actuators for its active control. Three LVDT (Linear Variable Differential Transformer) positioning sensors together with three horizontal and two vertical accelerometers are able to sense four degree of freedom (3 translations and a rotation around the vertical axis). The combination of these error signals by means of a Digital Signal Processor board (DSP) developed for this purpose, are used to determine the correction signals to be applied at the IP top stage to the coil-magnets actuators damping the normal mode of the chain (Inertial Damping – ID). This is the first active control along the chain able to reduce the residual motion of the suspension point down to a few tenths of micrometer (r.m.s.).

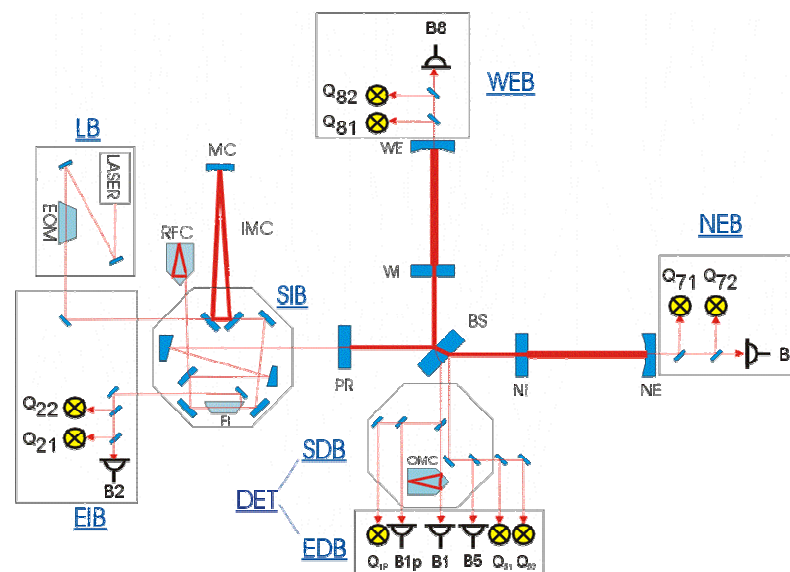

Fig. 1 VIRGO optical layout

The payload suspended from the last filter chain consists of a marionette, a reference mass and a mirror [6]. Four small permanent magnets screwed on the marionette wings together with the same number of coils attached to the end part of the last filter chain legs, represent the second actuation point for the active control of SA. From the marionette four thin wires start. The first pair supports the mirror in a cradle configuration and the second one, with the same technique, supports the reference mass surrounding the mirror itself. On the back side of this optical element four permanent magnets are glued while four coils screwed on the reference mass complete the last actuation point of the chain. This feedback control system (Local Control – LC) is based on optical lever sensors ground connected. Acting on the marionette, it is possible to reduce the mirror angular motion keeping the interferometer aligned within  $1 \mu\text{rad}$  r.m.s. or better. The last coil-magnet pairs (between mirror and reference mass) are used as electronic dampers to recover the position of each mirror after an interferometer un-lock without exciting the mechanical mode of the filter chain.

Finally, the main output signal is reconstructed by a set of high-quantum efficiency InGaAs photodiodes mounted on an optical bench outside of the vacuum vessel (External Detection Bench – EDB). The output beam, before reaching the photodiode B1 (see fig. 1), passes through a monolithic 2.5 cm long cavity (Output Mode Cleaner – OMC) installed on a suspended bench (Suspended Detection Bench – SDB) attached to a SA and maintained in vacuum. The OMC has been included in the VIRGO optical layout to filter the higher order optical modes originating from misalignments and optical defects.

### 3. Experimental set-up upgrades

After a first commissioning phase, the VIRGO Collaboration decided to perform relevant experimental set-up upgrades devoted to approach the detector design sensitivity. A detector shut-down period started in September 2005 and concluded about four months later has been devoted to fix important problems previously found. Two main changes have been introduced on the interferometer: a new flat monolithic PR mirror replaced the old curved one and a new Suspended Injection Bench (SIB) designed to overcome the annoying problem of the back-reflected light.

#### 3.1. The new Power Recycling mirror

The old suspended PR mirror was designed as a compound optical element consisting of an annular support and a central part with a curved secondary surface (120 mm in diameter) interconnected to the first one by means of a metallic ring. In addition, the PR lens was the final optical component of the input beam mode-matching telescope mounted on the SIB.

The main problem dealing with this composite structure was its inner resonance modes between 100 Hz and 500 Hz disturbing the interferometer controls.

The new flat PR mirror has a monolithic structure and a higher reflectivity (95% instead of 92%) with a diameter of 350 mm. Apart a higher recycling factor due to the increased reflectivity, with the new mirror many improvements have been performed at the longitudinal interferometer control level thanks to the absence of the inner resonance modes.

#### 3.2. The new Suspended Injection Bench

The new SIB has been designed fixing the main problem found during the first commissioning phase and limiting the interferometer performance: the back-reflected light interfering inside IMC. To this purpose the new bench has been equipped with Faraday Isolation (FI) system. The input beam mode-matching telescope has been completely re-designed taking into account the presence of a flat PR mirror. Two large parabolic off-axis mirrors (50 mm and 114 mm in diameter respectively) have been adopted assembling a tunable telescope in two angular degrees of freedom plus the focal length. A rigid metallic support interconnecting the two mirrors has been used to perform a preliminary telescope tuning on bench before installing it on the SIB (see fig. 2). Without changing the suspension geometry but reducing the diameter of the three metallic monolithic wires (1 mm each one instead of 2 mm with an interconnection element at mid length), the SIB has been hung under vacuum to its short SA.

During the commissioning of this new experimental set-up, the residual astigmatism of the parabolic telescope, remotely controllable with pico-metric displacements, has been measured to be of the order of 2-3%. Moreover, even if the two mirrors are mounted on large mechanical supports, no drawback linked to their inner resonance modes has been observed.

### 4. Preparing the first scientific run

The second phase of the detector commissioning, started in January 2006 after the installation of the up-grades mentioned above, was focused on two main aspects: the continuous improvements of the feedback control loops and the continuous interferometer noise reduction.

To achieve the complete interferometer locking, the VIRGO collaboration has developed the so called “variable finesse” technique [7], locking the interferometer outside the dark fringe working point. In this way a large fraction of the light escapes through the output port and the power buildup in the recycling cavity is slow. As a last step, the interferometer is brought adiabatically on the dark fringe. The technique is called “variable finesse” because the recycling cavity finesse is changed during the lock acquisition path.

Once the interferometer is locked another control loop is necessary to maintain the mirrors perfectly aligned one with respect to the other and with respect to the laser beam. Since the necessary accuracy is not achievable by using the ground based LC, an automatic alignment based on the Anderson technique [8] and using the light transmitted through the end mirrors has been implemented.

At the level of the suspension system, some important control loops have been added to overcome the difficulties in keeping the interferometer locked with bad weather conditions. A particular attention has been devoted to the development of a control strategy to re-allocate the locking force on the marionette and on top of the IP.

This activity has been also driven by the interferometer noise reduction which represented the second important aspect faced during this commissioning phase. Many noise sources limiting the interferometer sensitivity have been identified. In some cases the sensitivity improvement required a fine tuning of the control systems, while a better protection of the interferometer sensors from external disturbances together with environmental noise reduction helped a lot. Acoustic noise source, for instance, have been reduced adding isolating enclosures on in-air optical benches (EIB, EDB, WEB and NEB - see fig. 1).

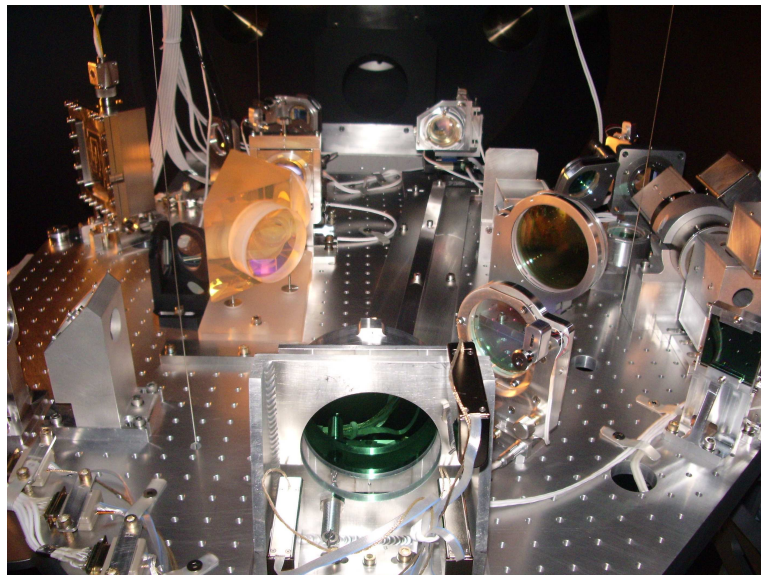

*Fig. 2 The new Suspended Injection Bench (SIB). The parabolic telescope is in foreground while the Faraday Isolator is on right side. On left side the two flat mirrors optically contacted to a dihedron and forming the Input Mode Cleaner cavity are also visible.*

All over the second commissioning period a set of Week-end Scientific Run (WSRs) with the interferometer operated at high power in recycled configuration has been organized since September 2006. Those runs have been important for the final tuning of the shifts organization, automatic procedures and for checking detector reliability and data taking process before a long run.

### **5. The first VIRGO scientific run**

The first VIRGO Science Run (VSR1) started on May 18<sup>th</sup>, 2007 in coincidence with the last period of LIGO S5 run. Even if the detector sensitivity was not the design one all over the bandwidth, in the frequency region 300 Hz-5 kHz the design sensitivity has been reached and it is comparable to the LIGO one (see fig. 3). This result has been considered appropriate to start joint data analysis with the LIGO Scientific Collaboration (LSC). In this context a Memorandum Of Understanding (MOU) has been signed between the two scientific communities that schedules full data exchange, joint data analysis and joint publications.

The VSR1 has been stopped on October 1<sup>st</sup>, 2007 (in coincidence with the end of S5) after about four months of continuous data taking. The detector duty-cycle in science mode has been as high as 81% thanks to the full locking automation procedure [9] developed during the commissioning phase and the control strategy improvements. The interferometer sensitivity expressed in terms of maximum distance at which a coalescing system formed by two neutron stars with 1.4 solar masses would be detectable, reached a mean value of 4 Mpc.

### **6. Future perspectives and upgrades**

The VIRGO design sensitivity will allow testing some of the present gravitational wave amplitude upper limits. Even if a first detection is possible, the sensitivity of VIRGO and LIGO detectors are not sufficient to open the era of gravitational wave astronomy. Moreover, any potential gravitational wave signal detection

should be done by a coincidence of different interferometers having a common sensitivity on a large bandwidth to be considered as a network. For these reasons it is important to prepare an up-grade of the present apparatus improving the design sensitivity of a factor 2 (VIRGO+), so that an increment of a factor 10 or more in the detection rate will be reachable.

The VIRGO collaboration is planning a first set of detector up-grades, VIRGO+ [10], which should be completed (commissioning included) within the first half of 2009. After this phase the detector should be ready for data taking in coincidence with enhanced LIGO (eLIGO).

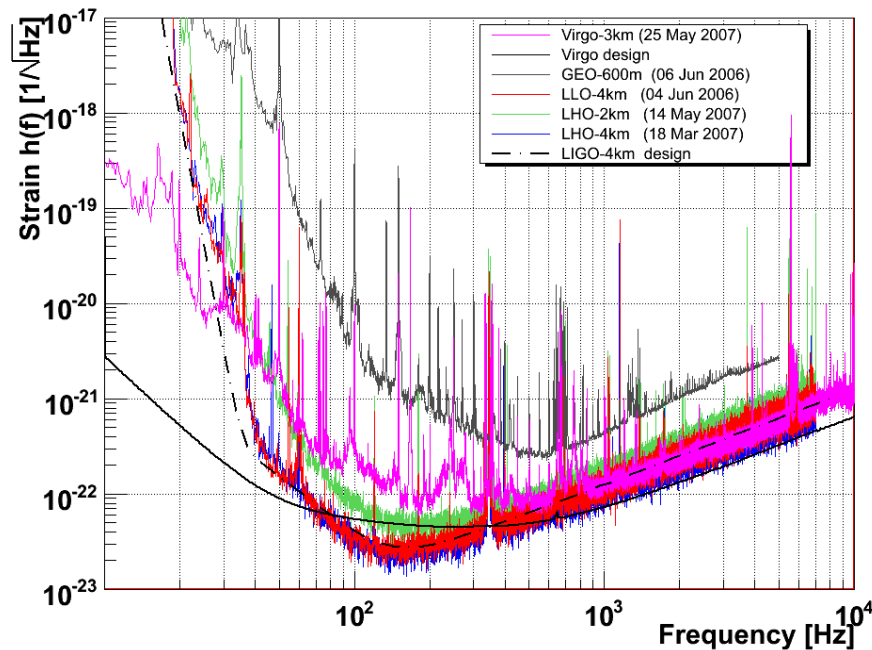

Fig. 3 Sensitivity curves comparison for different detectors (VIRGO, LIGO and GEO-600m)

Since the seismic isolation system (SA) is compliant with the design sensitivity improvement, the scheduled changes will concern:

- the installation of new IMC payload;
- the installation of a system for thermal compensation of the mirrors;
- the improvement of the input laser power (up to 50 watt) by using a new laser amplifier;
- the installation of new control system electronics;
- the installation of new mirrors increasing the Fabry-Perot cavities finesse up to 150.

A more substantial up-grades campaign will take place at the beginning of the next decade, when a second generation detector, called Advanced VIRGO (AdV) [11], will be installed in the present infrastructure. In this case the main goal is to improve the present design sensitivity by one order of magnitude, increasing the event rate by three orders of magnitude. The conceptual design document of AdV is expected to become available by the end of 2007. A dedicated R&D program is in progress with the goal to start the engineering phase in 2010.

## 7. Conclusion

The first VIRGO Science Run (VSR1) is ended on October 1<sup>st</sup>, 2007 after more than four months of continuous data taking. The detector duty-cycle in science mode configuration has reached the 81% with about 20 sets of un-interrupted data collection longer than 40 hours very promising for future data analysis. These very good results have been obtained thanks to the locking automation procedure and to the fine tuning of the complex feedback control systems. Even if the design sensitivity is not yet reached all over the bandwidth, the VIRGO interferometer shows the best sensitivity in the frequency range below 35 Hz.

**References**

- [1] <http://www.virgo.infn.it>
- [2] <http://www.ligo.caltech.edu>
- [3] <http://www.geo600.uni-hannover.de>
- [4] G. Ballardini et al., Rev. Sci. Instr., vol. 72, n. 9, (2001) 3643-3652
- [5] S. Braccini et al., Astro. Phys. 23 (2005) 557-565
- [6] A. Bernardini et al., Rev. Sci. Instr., vol. 70, n. 8, (1999) 3463-3472
- [7] F. Acernese et al., Class. Quant. Grav. 23: S85-S89, (2006)
- [8] D.Z. Anderson, Appl. Opt., 23, 2944-2949 (1984)
- [9] F. Acernese et al., Proceeding of the International Conference on Accelerator and Large Experimental Physics Control System (ICALEPS), Geneva, Switzerland, 10-15 Oct. (2005)
- [10] F. Acernese et al., J. Phys. Conf. Ser. 32: 223-229, (2006)
- [11] R. Flaminio et al., 'Advanced Virgo White Paper', VIR-NOT-DIR-1390-304, (2005)