

Voice Recognition Wireless Home Automation System Based On Zigbee

Dhawan S. Thakur¹ and Aditi Sharma².

Eternal University, Himachal Pradesh, India

Abstract : *In the recent years, the Home Automation systems has seen a rapid changes due to introduction of various wireless technologies The explosion in the wireless technology has seen the emergence of many standards, especially in the industrial, scientific and medical (ISM) radio band. ZigBee is an IEEE 802.15.4 standard for data communications with business and consumer devices. Zigbee is targeted at applications that requires low data rate, long battery life, and secure networking. Zigbee has a defined rate of 250 kbits/s, best suited for periodic or intermittent data or a single signal transmission from a sensor or input device. The wireless home Automation systems is supposed to be implemented in existing home environments, without any changes in the infrastructure. The automation centers on recognition of voice commands and uses low-power ZigBee wireless communication modules along with microcontroller. This system is most suitable for the elderly and the disabled persons especially those who live alone and since recognize voice so it is secure. The home automation system is intended to control all lights and electrical appliances in a home or office using voice commands. So in this paperwork our aim is to designed a voice recognition wireless ZigBee based home automation system.*

Keywords - *Home automation, Microcontroller , Voice Recognition, ZigBee, Power Supply.*

I. INTRODUCTION

The Wireless Home Automation System is an integrated system to facilitate elderly and disabled people with an easy-to-use home automation system that can be fully operated based on speech commands. The system is portable and constructed in a way that is easy to install, configure, run, and maintain.

A typical wireless home automation system allows one to control house hold appliances from a centralized control unit which is wireless. These appliances usually have to be specially designed to be compatible with each other and with the control unit for most commercially available home automation systems. The project demonstrates a system that can be integrated as a single portable unit and allows one to wirelessly control lights, fans, air conditioners, television sets, security cameras, electronic doors, computer systems, audio/visual equipment's etc. and turn on or off any appliance that is plugged into a wall outlet, get the status of different sensors and take decision accordingly. The overall system is controlled from a microphone which is connected with HM 2007 speech recognition chip. This chip sends the voice commands in binary sequence to microcontroller. The base station unit takes decision and send the commands to remote station by ZigBee transceiver. The remote system receives the commands through ZigBee transceiver and performs the request function. The sensors unit is capable of detecting when the user enters or leaves the room by measuring the change in signals strength between the access Point and can accordingly turn on or off appliances such as lights and fans and in the meantime send its status back to base station.

II. System Overview

The home automation system contains both a base station and a remote station. Each station will be packaged separately and have a separate PCB.

2.1 BASE STATION

The base station will operate with a +5V power supply. This voltage will be used as the operating voltage for all of the circuit elements in the base station. The microphone in the base station will be picking up audio in a close range. The audio signal from the microphone will be input into the HM 2007 speech recognition chip. The HM 2007 chip will process the audio and determine if the commands are speech commands and valid then it will pass the commands through microcontroller and ZigBee to remote station where the matched command operation will be performed . A 16 x 2 LCD interfaces with the microcontroller to display the current status of the sensors and relay switches on/off state. A sound alarm is given in the base station as well as in the remote station which indicate the status of water level either water in the tank is overflowing (To off the water motor) or below limit(To on).The HM 2007 chip does voice analysis and recognition on the microphone audio signals. The HM 2007 interfaces directly with a microphone and the microcontroller in turn interfaced with ZigBee transceiver. The word length to be recognized will be selected to

be the highest amount of 1.92 seconds. This will allow a maximum of 20 words to be memorized with the 8K-byte memory used. This will suit the needs of our product, as the speech commands will never surpass 20 words. measuring the change in signals strength between the access Point and can accordingly turn on or off appliances such as lights and fans and in the meantime send its status back to base station.

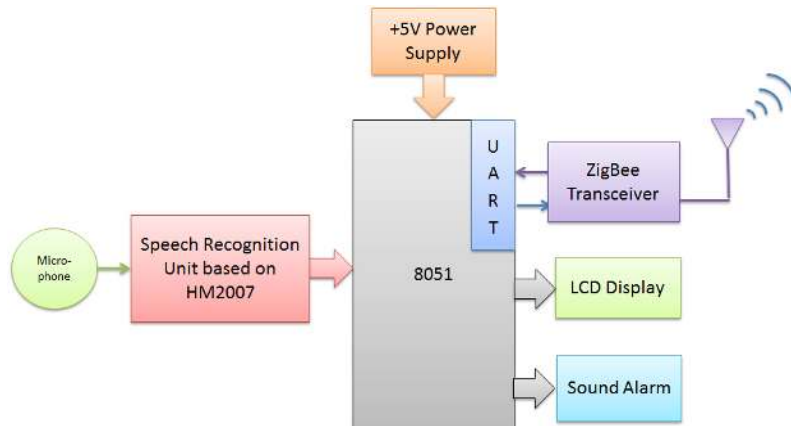

Figure 1. Handheld microphone with voice recognition unit in the base station

1.1 REMOTE STATION

The remote station will operate with same +5 V power supply. The remote station microcontroller receives the digital signal commands from the base station using the Zigbee wireless protocol and performs the request function. On the basis of command signals received it will update the status of relay switches board. It also read the sensors values and update the LCD status on the remote station. The sensors unit is capable of detecting when the user enters or leaves the room by measuring the change in signals strength between the access Point and can accordingly turn on or off appliances such as lights and fans and in the meantime send its status back to base station.

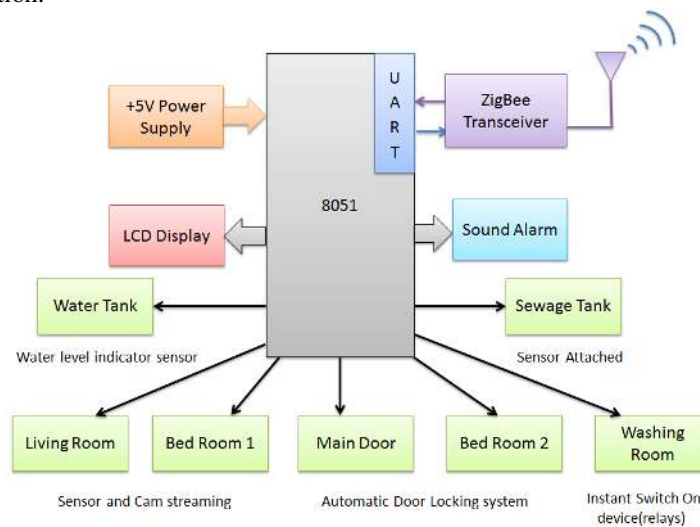

Figure 2. Functional Block Diagram of Remote station Unit

III. Project Design Methodology

This section will discuss the methodology involved in the design of the Voice Recognition Wireless Home Automation System Based On ZigBee. The project was divided into parts to make the design process modular. In the prototype board fabricated by the authors, these parts replaced with their specifications are:

3.1 Speech Recognition Unit: The heart of speech recognition system is HM2007 voice recognition IC. The IC can recognize 20 words, each word a length of 1.92 seconds

3.2 ZigBee: It is a low-cost, low-power, wireless networking standard. The low cost allows the technology to be widely deployed in wireless control and monitoring applications, the low power-usage allows longer life with smaller batteries, and different networking topologies provides high reliability and larger range.

3.3 Microcontroller: Any 8-bit microcontroller can be configured with the system. Here we have used 8051 microcontroller(AT89S51)-full static CMOS controller, 8k Flash memory, 256 bytes RAM,4 I/O ports of 8 bit wide, 3 timers/counters, 8 interrupt sources etc.

3.4 Liquid Crystal Display(HD 162A): 16x2 LCD that is 16 character per row.

3.5 Power supply unit.

3.6 Different sensors, relay switches board and sound alarm.

3.1 SPEECH RECOGNITION UNIT

The speech recognition system is a completely assembled and easy to use programmable speech recognition circuit. Programmable, in the sense that we can train the words that we want the circuit to recognize. This circuit board allows us to experiment with many facets of speech recognition technology. It has 8 bit data out which can be interfaced with any microcontroller for further development.

3.1.1 FEATURES

- User programmable
- Up to 20 word vocabulary of duration two second each
- Multi-lingual
- Non-volatile memory back up with 3V battery backup which will keep the speech recognition data in memory even after power off.
- Easily interfaced to any microcontroller like 8051, PIC or AVR can be interfaced to data port.

3.1.2 HM2007

It is a single chip CMOS voice recognition LSI circuit with the on-chip analog front-end, voice analysis, recognition process and system control function.

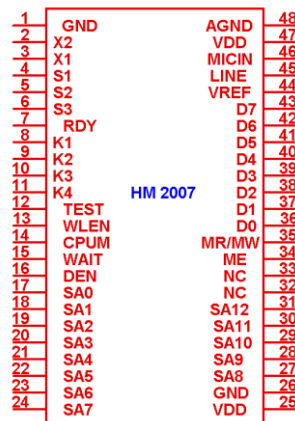

Figure 3. Functional Pin Description of HM 2007

A 20 isolated word voice recognition system can be composed of external microphone, keyboard, 8K SRAM and other components, combined with a microcontroller, an intelligent recognition system can be built. It support two control mode: Manual mode and CPU mode. It is also available in 48-pin PDIP. The pin description of HM2007 is shown above.

The keypad and digital display are used to communicate with and program the HM2007 chip. The keypad is made up of 12 normally open momentary contact switches. The 74LS373 8-bit registers feature 3-state outputs designed specifically for driving highly capacitive or relatively low-impedance loads. The high-impedance 3-state and increased high-logic-level drive provide these registers with the capability of being connected directly to and driving the bus lines in a bus-organized system without need for interface or pull-up components. The IC 7448 is BCD to 7-segment common cathode IC. To display the data, we have to convert it from BCD to 7-segment code. The IC makes this process. It has four inputs called BCD inputs and seven outputs to drive the display. The voice recognition system schematic diagram is shown below in fig.4.

A microphone is connected directly with pin 15(MICIN) of HM2007which is shown below. On this system, voice is trained first and then recognized whenever a command is given through microphone.

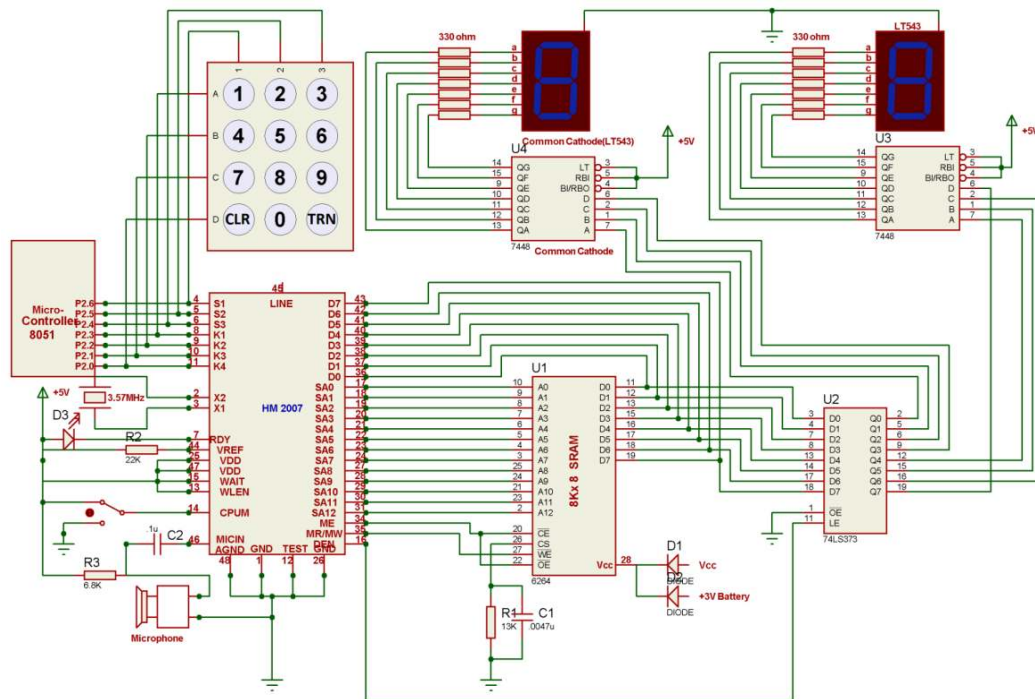

Figure 4. Schematic diagram of Voice Recognition System With Manual and CPU Mode Option

The speech recognition system is a completely assembled and easy to use programmable speech recognition circuit. Programmable, in the sense that we train the words (or vocal utterances) which we want the circuit to recognize. This board allows us to experiment with many facets of speech recognition technology. It has 8 bit data out which can be interfaced with any microcontroller for further development. Some of interfacing applications which can be made are controlling home appliances, robotics movements, Speech Assisted technologies, Speech to text translation, and many more. It has Non-volatile memory back up with 3V battery onboard which will keep the speech recognition data in memory even after power off.

3.1.3 SYSTEM WORKING

There are two mode which are supported by this system, Manual mode and CPU mode

3.1.3.1 MANUAL MODE

This mode is selected by connecting Pin 14(CPUM) to ground by using SPDT switch. When the circuit is turned on, “00” is on the digital display, the red LED (contacted with READY pin) is lit and the circuit waits for a command. By using this mode we can do following task:

- Training Words for Recognition:
- Testing Recognition:
- Error Codes Detection in 7-segment display. This happens when the voice command is too short or too long.
- Clearing Memory.

3.1.3.2 CPU MODE

This mode is used when we want to perform additional functions or want to make our system smart, this is done by connecting voice recognition system with the microcontroller. This mode is selected by connecting Pin 14(CPUM) to Vcc by using SPDT switch. In this mode K-bus is used as a bidirectional data bus between the microcontroller and HM2007 and S1 to S3 as R/W control pins. The several function provide by CPU modes which are similar to manual mode are :

- RECOG
- TRAIN
- RESULT
- UPLOAD
- DOWNLOAD
- RESET

3.2 ZIGBEE

The explosion in wireless technology has seen the emergence of many standards, especially in the industrial, scientific and medical (ISM) radio band. There have been a multitude of proprietary protocols for control applications, which bottlenecked interfacing. Need for a widely accepted standard for communication between sensors in low data rate wireless networks was felt. As an answer to this dilemma, many companies forged an alliance to create a standard which would be accepted worldwide.

It was this ZigBee Alliance that created ZigBee. Bluetooth and Wi-Fi should not be confused with ZigBee. Both Bluetooth and Wi-Fi have been developed for communication of large amount of data with complex structure like the media files, software etc. ZigBee on the other hand has been developed looking into the needs of communication of data with simple structure like the data from the sensors.

ZigBee has been developed to meet the growing demand for capable wireless networking between numerous low power devices. In industry ZigBee is being used for next generation automated manufacturing, with small transmitters in every device on the floor, allowing for communication between devices to a central computer. This new level of communication permits finely-tuned remote monitoring and manipulation.

The ZigBee and ZigBee Pro radio is made by Digi (formerly Maxstream) which is shipped with firmware implementing the IEEE 802.15.4 protocol. These modules use the IEEE 802.15.4 networking protocol for fast point-to-point or peer-to-peer networking. However, the most different part between ZigBee and ZigBee Pro is they have different cover distance range for communicate with own module. ZigBee can be covers around 30m at indoor and 100m at outdoor. Inversely, ZigBee Pro can cover higher distance range than ZigBee which is 100m at indoor and 1500m at outdoor. Both devices that have a UART interface so can be connected directly from microcontroller to pins of RF Module (ZigBee/ZigBee Pro). Using UART interface, we can use this wireless devices to communicate between microcontroller to microcontroller (two 8051's) or between PC to microcontroller or between PC to PC. Here, we will discuss how to use two ZigBee/ZigBee Pros to interface with microcontroller and how to send command for configuration ZigBee/ZigBee Pro Module. The role of the Zigbee module is to be as transparent as possible. It should be as if a wire was connecting the input to the output and connectivity is never lost. While this sounds simple, it's actually a very hard task to accomplish and error correction is a must, which the Zigbee's role in offering sound and reliable wireless communication. ZigBee pin diagram is shown below:

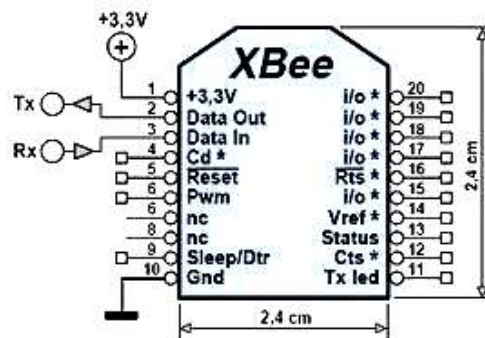

Figure 5. ZigBee pin configuration

Looking at the ZigBee pinout we can see right away the different types of input that can be translated and transmitted wirelessly:

- Digital I/O
- Analog I/O (10 bit resolution)
- Pulse with Modulation
- Serial Communication (SPI/RS232/I²C)
- CTS/DTR Control Signals

These are some the most common types of signals that are used in electronics and the ZigBee offer them all as inputs and outputs.

3.2.1 XBEE/XBEEPRO HARDWARE INTERFACE BETWEEN PC

Here I have used two different ZigBee starter kit one is USB compatible kit with PC and other one is RS232 protocol compatible with PC. I have connected one of the starter kit with the USB port and the other one with Serial Com port of same or different PC (depends upon choice). Bear in mind, ZigBee is designed for 3.3V system, this starter kit have inbuilt 3.3V regulated power supply so we don't need to worry about this. Those system in which we want to connect ZigBee as a stand-alone device will require extra work and component before ZigBee module could be embedded in the system. Next step is to set ZigBee Module Source address and Destination address, it is very important for us to transfer data by transparently from one ZigBee module

(Source) to another ZigBee module (Destination) so that it don't interfere with other module in the same network. Two ways to setting ID address which is using [X-CTU software](#) or using programming code to send specified command for ZigBee ID address setting. We will discuss only one way of configuring ZigBee module by using X-CTU software only since this is sufficient for our research paper work.

X-CTU which is a computer based software to communicate with ZigBee, to change configuration or Transmit/Receive data. Double click the "setup_x-ctu.exe" file to install this Software.



Figure 6. Using X-CTU software to setting Source address or Destination address.

Launch the X-CTU Software and connect the USB cable from USB compatible starter kit to any of the USB port (without connecting to microcontroller board). Select "PC Setting" tab under X-CTU software window → select *USB Serial Port (Here it is COM 12 appeared and unaltered all the other settings)* → Now click "TEST/QUERY" as shown in Fig. 7.1.

All the other settings like -Baud rate: 9600- Data bits: 8 - Parity: NONE - Stop bits: 1 and others are unchanged or could be changed according to data transmission rate required.

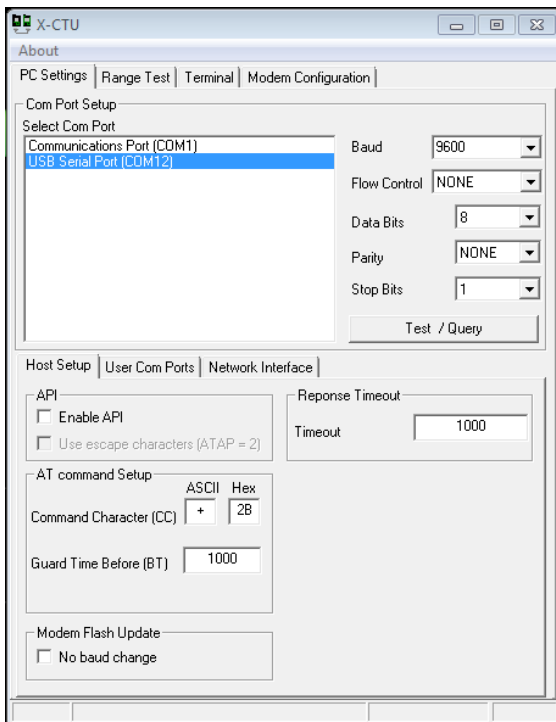

Figure 7.1
ZigBee Coordinator

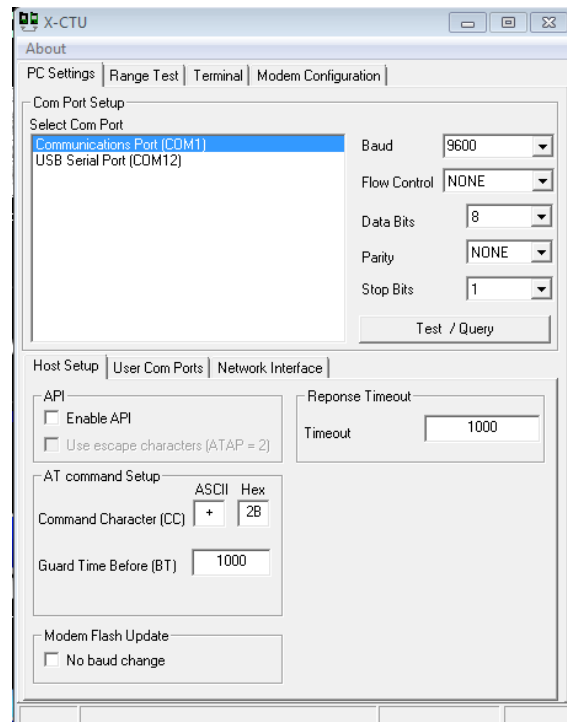

Figure 7.2
ZigBee Router (End Device)

Configuring By Using X-CTU Software.

If everything is fine, a dialogue box will appear as shown below in Fig.8.1, click "OK" to close this box:

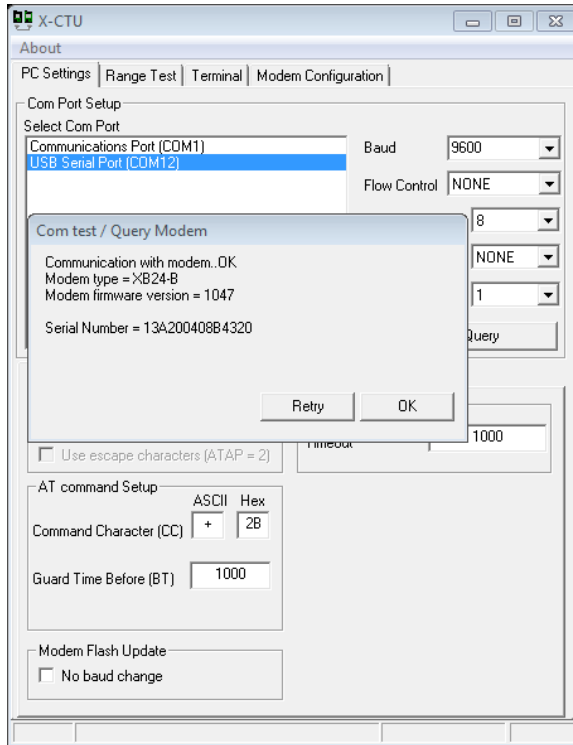

Figure 8.1
ZigBee Coordinator

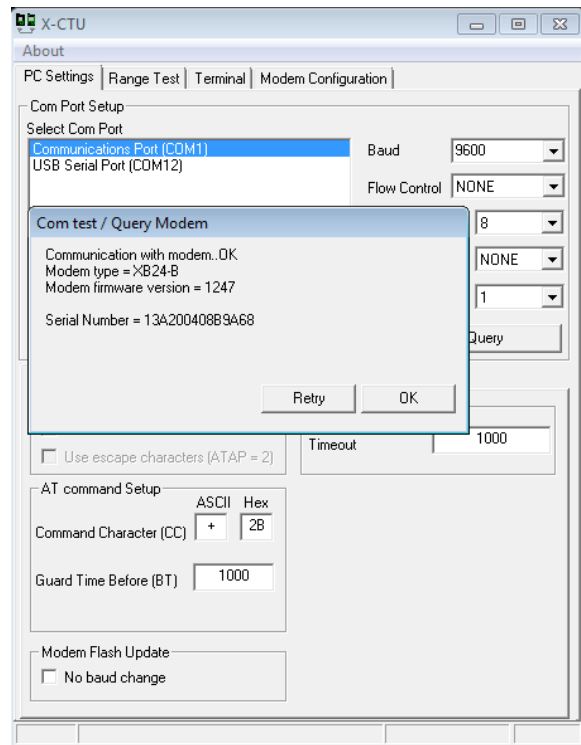

Figure 8.2
ZigBee Router (End Device)

Configuring By Using X-CTU Software.

Now repeat the same steps with the other serial com port compatible starter kit. Connect the cable of starter kit with the com port of PC. Run the X-CTU software. Select “PC Setting” tab under X-CTU software window → select *serial COM Port* (Here it is COM 1 appeared and unaltered all the other settings) → Now click “TEST/QUERY” as shown in Fig. 7.2. If everything is fine, a dialogue box will appear as shown in Fig 8.2, click “OK” to close this box. Here we have used the single PC Serial Com Port and USB port for the testing purpose. As shown in the figure 8 the modem type is XB 24-B so click now on the Modem Configuration Tab.

- ➔ Select modem XBEE type (as it is XB 24-B)
- ➔ Click on the Function set and select Coordinator AT (For point to point communication AT command mode is simplest)
- ➔ Choose always update firmware
- ➔ Click on write.

Within a few seconds the new firmware will be installed on ZigBee. Keep the other settings unchanged as shown in Fig. 9.1. Similarly go to second X-CTU window as shown in the Fig. 8.2 here again the modem type is XB 24-B so click now on the Modem Configuration Tab.

- ➔ Select modem XBEE type (as it is XB 24-B)
- ➔ Click on the Function set and select Router/End Device AT
- ➔ Choose always update firmware
- ➔ Click on write

Within a few seconds the new firmware will be installed on ZigBee. Keep the other settings unchanged as shown in below Fig.9.2.

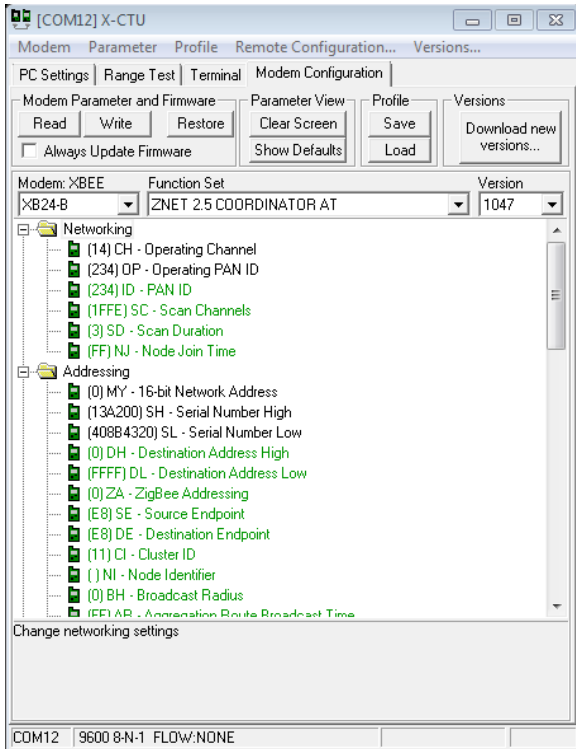

Figure 9.1
ZigBee Coordinator

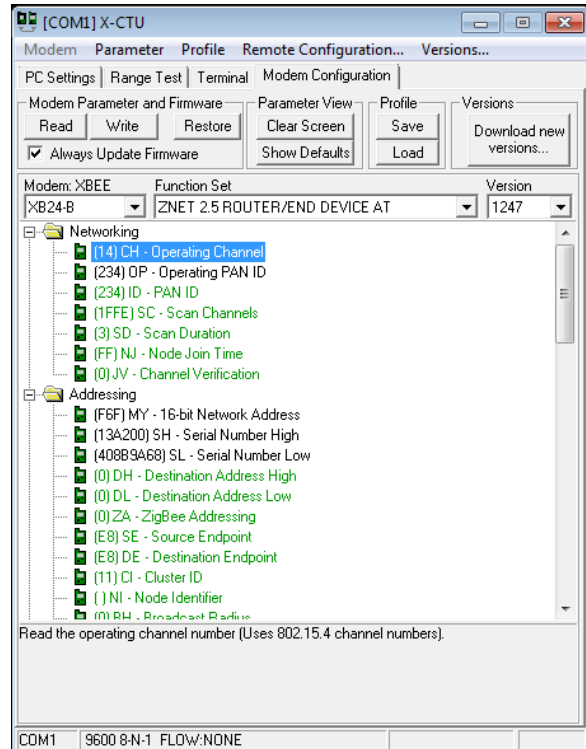

Figure 9.2
Zigbee Router (End Device)

Modem Configuration.

Now go to Range Test Tab and in both X-CTU windows click on start if everything is done correctly the both ZigBee start communicating each other as shown in below picture. Now both the ZigBee module are configured successfully and can be attached with remote station and base station microcontroller board. The range test is shown below in Fig.10 .

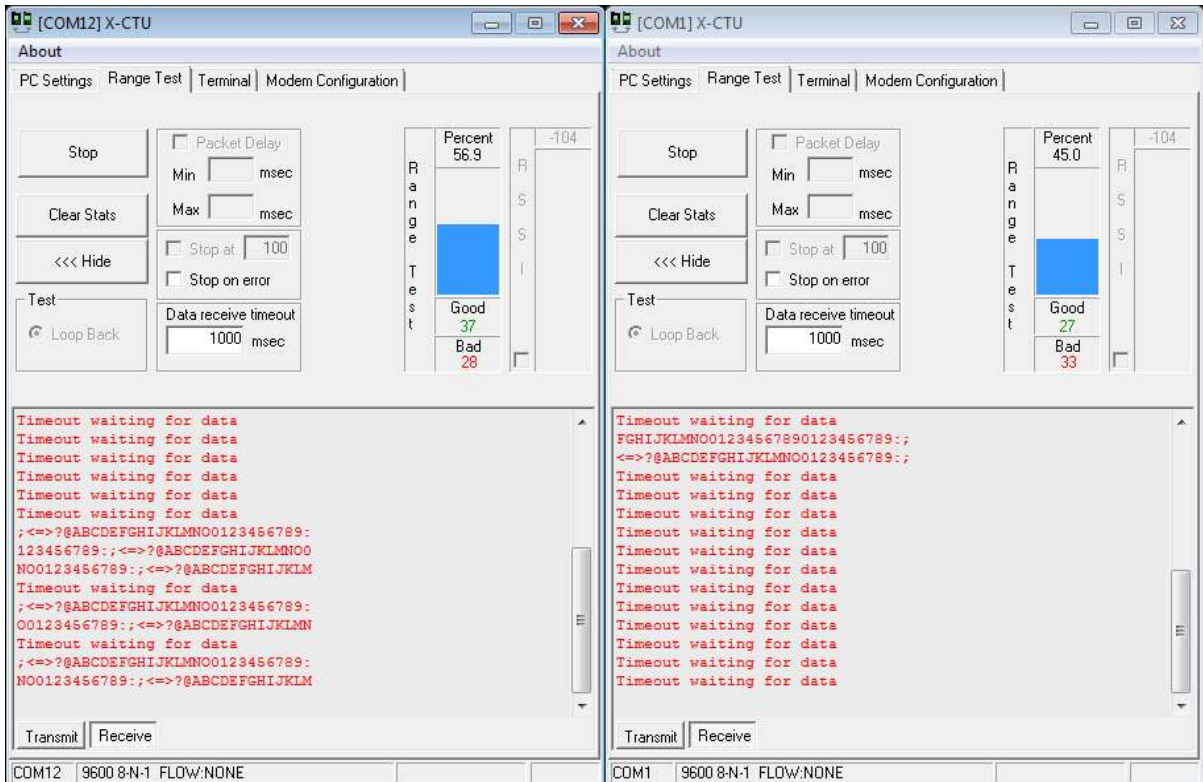

Figure 10. Range Test Between Co-ordinator and Router/End Device

3.2.2: ZIGBEE / ZIGBEEPRO HARDWARE INTERFACE BETWEEN MICROCONTROLLER

If we want to use coding to send the command to ZigBee, we have to ensure the hardware connection between Zigbee to microcontroller is complete. Any microcontroller with UART peripheral can be used to interface with ZigBee as shown below:

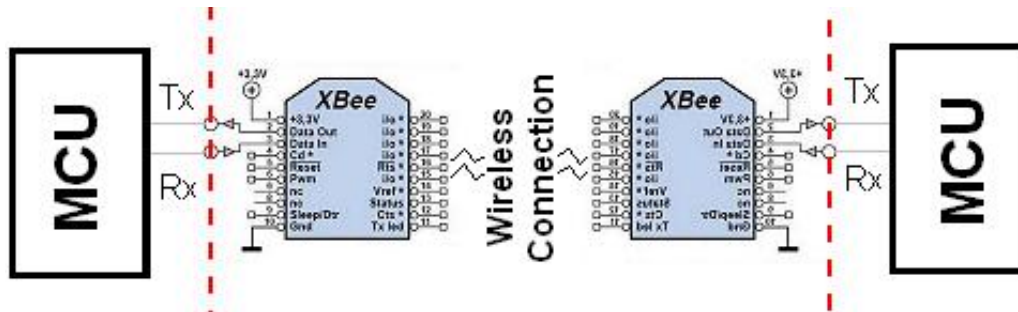

Figure 11. Standard ZigBee wireless communication link with microcontroller

The way we will be using the Zigbee is far easier. Straight out of the box, the Zigbee is normally configured for 9600bps serial communication and so to make things easier, we haven't change any of the configuration options. This means we will only be using the Vcc, GND, Din and Dout pins and left other pins unconnected. In Fig.11 we have connected RXD pin no.3of ZigBee to TXD pin of microcontroller and ZigBee TXD pin no. 2 to RXD pin of microcontroller.

3.3 MICROCONTROLLER 8051

Since the project's focus is on embedded hardware and software control, the microcontroller is the heart of the system. The microcontroller selected for this project must be able to read values from sensors through analog to digital convertor, send and receive signals from RF module and must be able to display them to LCD. Any 8-bit microcontroller can be chosen for this purpose. The AT89S51 was selected as it satisfies these requirements

A 11.0592 MHz crystal oscillator was also used in conjunction with the 8051 to provide the necessary clock input. This speed is sufficient for the application. A pin diagram of the AT89S51 is provided in Figure 12.

The inbuilt capabilities of 8051 microcontroller (AT89S51) are

- It is a full static CMOS controller
- 8k Flash memory
- 256 bytes RAM
- 4 I/O ports of 8 bit wide
- 3 timers/counters
- 8 interrupt sources etc.

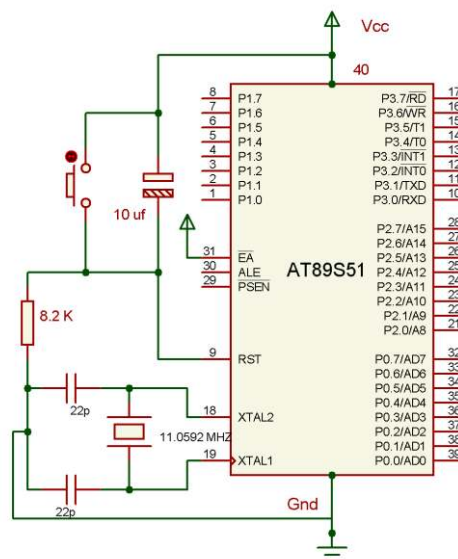

Figure 12. 8051 Microcontroller with basic connection

3.4 LIQUID CRYSTAL DISPLAY (LCD)

Here we are using a 16 x 2 LCD for displaying the values on the screen. It has 16 pins. It support 16 characters per rows and total no of rows are 2. It means that it can support up to 32 character at a time, which is sufficient for data display purpose. RS, R/W and Enable pins of LCD are connected with the receiving end microcontroller port pins. Data lines D0-D7 are connected to one of the output port of microcontroller.

The basic connection of LCD is shown below in figure 13. Here V_{DD} (contrast voltage) is adjusted by using a variable resistor connected with it.

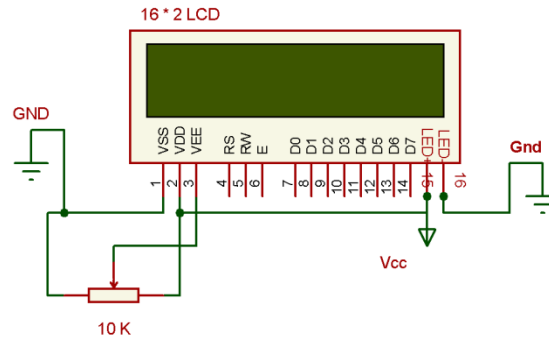

Figure 13. LCD Basic Connection Diagram

3.5 POWER SUPPLY UNIT

In the power section a simple 9-12V battery is connected with the transmitting end as well as receiving end. Since the microcontroller which is the central processing unit works on regulated +5V power supply so this can be achieved by connecting a +5 volt regulator at the output of battery. This is shown in figure 14.

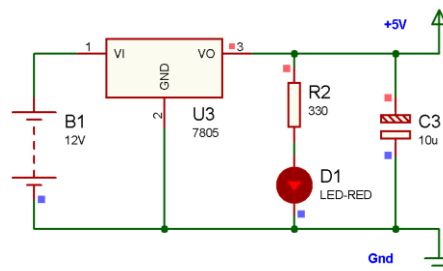

Figure 14. Battery operated +5V power supply

3.6 OTHER COMPONENTS:

A single relay switch connection to microcontroller are shown below. Any home appliance operating under A.C voltage supply could be connected directly with this relay interface circuit. A buzzer can also be connected by applying +12V at the common terminal of relay. Remaining relays of the interface circuit board could also be configured with the microcontroller in the similar fashion.

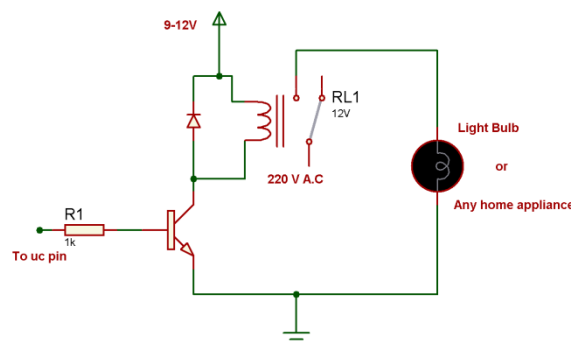

Figure 15. Relays switch board interfacing with the microcontroller

Similarly different sensors could be interface with the microcontroller by using analog to digital convertor or comparator circuit. So any sensors can be connected with the remote station according to the system requirement.

IV. Software Design

Software design includes voice recognition, transmission and reception of wireless signal using ZigBee transceiver, read the sensors, update the status of relay switches and display the status on LCD display accordingly.

The main program for this system is written by using the embedded C programming language. The schematic diagram for this system which consists of all the components was designed by using the Proteus ISIS 7 professional editions. The main program was developed in the Keil Integrated Development Environment by using the embedded C programming language. The .c program was converted into .HEX file in this IDE and burned into the ROM part of the AT89S51 microcontroller.

V. Scope And Conclusion

Voice recognition Wireless Home Automation Based on ZigBee is a very useful project for the adults and physically disabled persons, who are not able to do various activities efficiently when they are at home and need one's assistant to perform those tasks. With the Voice Recognition along with ZigBee network we can eliminate the complication of wiring in case of wired automation and also it prevent to get up and down again and again to on/off appliances. ZigBee Home Automation provides operating range much higher as compared to Bluetooth and other wireless sensor module .With the use of ZigBee Home Automation circuit considerable amount of power saving is possible and it is flexible and compatible with future technologies so it can be easily customized for individual requirements. On the other hand with voice recognition system, it provides secure access to home. So when we are living in a fast world where everything is changing with in no time such security is essential.

References

- [1]. Y.Usha Devi 1, II M.Tech, Wireless Home Automation System Using ZigBee, *International Journal of Scientific & Engineering Research Volume 3, Issue 8, August-2012 ISSN 2229-5518*.
- [2]. www.imagesco.com/articles/hm2007/SpeechRecognitionTutorial01.html
- [3]. Itp.nyu.edu/
- [4]. ZigBee Alliance Official Site, [online].Available: www.zigbee.org
- [5]. Prof. Jitendra R. Rana, Prof. S.N.Pawar, ZigBee Based Home Automation, <http://ssrn.com/abstract=1587245>
- [6]. "XBee-2.5-Manual," ZigBee RF communication protocol. (2008). Minnetonka: Digi International Inc.
- [7]. *XBee OEM RF Modules - ZigBee - v1.x1x [2007.06.01] © 2007 Digi International, Inc.* www.digi.com
- [8]. http://www.pyroelectro.com/tutorials/xbec_wireless_interface
- [9]. Lakhya1, Inder2, Emanuel3, Abhijit4, Lalan5, Debraj6, Er. M. Sujitha7, Home Automation System Based On Arm And Zigbee, *Undergraduate Academic Research Journal (UARJ)*, ISSN: 2278 – 1129, Volume-1, Issue-3,4, 2012.
- [10]. Muhammad A Mazidi , Janice Mazidi , *The 8051 Microcontroller And Embedded systems*, person Education second Edition ,printed in India by Gopson papers Ltd.
- [11]. Dhawan S. Thakur and Aditi Sharma, Wireless Solar Irradiance Meter, *International Conference On Re-Newable Energy,5th-6thMay., 2012, Eternal University, H.P., INDIA*
- [12]. V. Ramya, B. Palaniappan, Boby George, Embedded System for Automatic Irrigation of Cardamom Field using Xbee-PRO Technology, *International Journal of Computer Applications (0975 – 8887) Volume 53– No.14, September 2012*.



Dhawan S. Thakur is presently working as Lecturer in the department of Electronics and Communication Engineering, Eternal University, India. His area of interest is Microcontroller & Embedded Systems, Renewable Energy.



Aditi Sharma is presently working as Asst. Professor in the department of Electronics and Communication Engineering, Eternal University, India. Her area of interest is Microcontroller & Embedded Systems and Microstrip Patch Antenna at TeraHertz Frequencies.