

Volterra Distortions, Spinning Strings, and Cosmic Defects

Roland A. Puntigam¹

Institute for Theoretical Physics, University of Cologne, D-50923 Cologne, Germany

Harald H. Soleng^{2,3}

Theory Division, CERN, CH-1211 Geneva 23, Switzerland

Abstract

Cosmic strings, as topological spacetime defects, show striking resemblance to defects in solid continua: distortions, which can be classified into disclinations and dislocations, are line-like defects characterized by a delta function-valued curvature and torsion distribution giving rise to rotational and translational holonomy. We exploit this analogy and investigate how distortions can be adapted in a systematic manner from solid state systems to Einstein–Cartan gravity. As distortions are efficiently described within the framework of a $SO(3) \times T(3)$ gauge theory of solid continua with line defects, we are led in a straightforward way to a Poincaré gauge approach to gravity which is a natural framework for introducing the notion of *distorted spacetimes*. Constructing all ten possible distorted spacetimes, we recover, inter alia, the well-known exterior spacetime of a spin-polarized cosmic string as a special case of such a geometry. In a second step, we search for matter distributions which, in Einstein–Cartan gravity, act as sources of distorted spacetimes. The resulting solutions, appropriately matched to the distorted vacua, are cylindrically symmetric and are interpreted as spin-polarized cosmic strings and cosmic dislocations.

PACS numbers: 04.20.-q 04.50.+h 61.72.Lk

CERN-TH/96-26 (revised)

February 1996, revised November 1996

¹ Electronic address: rap@thp.uni-koeln.de

² Electronic address: harald@nordita.dk

³ Present address: NORDITA, Blegdamsvej 17, DK-2100 Copenhagen Ø, Denmark

1 Introduction

One of the most interesting features of the spacetime of a straight cosmic string [1–3] in general relativity is its conical structure [4, 5]. If the string is investigated within the Einstein–Cartan theory (EC theory) of gravity [6], then the geometry of the string spacetime may additionally have a chiral structure [7, 8]. More precisely, the string represents a topological defect of spacetime that may be described in geometrical terms by delta function-valued torsion and curvature components.

It has been noticed by several authors that the spacetime geometries of cosmic strings in 3 + 1 dimensions [9–12] exhibit some close relations to so-called *distortions* of solids, which may likewise be regarded as topological defect lines carrying torsion and curvature. Similar analogies hold in 2+1 dimensional gravity [13, 14], where the spacetime geometry of a point particle can be understood in terms of distortions. This point has recently been studied in detail by Kohler [15, 16].

Distortions were introduced by Volterra [17] in the context of the theory of elasticity and have later been subject to innumerable investigations in the context of both solid continua and crystals, see, for instance, Nabarro [18], Kléman [19], Kröner [20], and references therein. It is remarkable that already Nabarro mentioned the possible existence of timelike distortions [18, p. 588] and the resemblance of Marder’s cylindrically symmetric solution [21, 22] of the Einstein equation to distortions.

In this article, we intend to investigate in a systematic way the above-mentioned analogy between distortions of solids and defect structures of Riemann–Cartan manifolds. This is done by means of a reexamination of the classical Volterra process, see below, which results naturally in the construction of what we call *distortions of spacetime*. The straight cosmic string is the most prominent example of such a geometry.

In the EC theory of gravity, we have two kinds of sources: energy-momentum, which generates curvature just as in ordinary Einsteinian gravity, and spin-angular momentum, generating torsion. If we want to construct some matter distribution which has as its exterior spacetime the defect spacetime under consideration, we can think of to two inequivalent strategies. Taking the cosmic string as a prototype, it may, on the one hand, be considered as a *thin string* of zero width; on the other hand, the interior spacetime can be modeled as a *thick string*, i.e. as a cylinder with finite radius. There are two reasons for adopting the latter approach in the present investigation.

First of all, gauge theories that allow for string formation during spontaneous symmetry breaking predict extremely thin, but finite strings, whose radii depend on the energy scale of symmetry breaking [3]. Secondly, it has been shown by Geroch and Traschen [23] that—due to the nonlinearity of the field equations—it is mathematically ambiguous to define matter currents corresponding to thin strings (see, however, the recent work by Clarke et al. [24] for a possibility to deal with two-dimensional distributional sources by means of Colombeau’s new generalized functions). Interior solutions with finite radius have already been found for massive strings in general relativity [25, 26] and spin-polarized strings in EC theory [27, 28]. Here, we use this construction to find interior solutions that can be matched to more general defect spacetimes.

We have organized this article as follows: in Section 2 we generalize the Volterra process to 3 + 1 dimensions using differential geometric and gauge theoretic methods and study explicit examples of Volterra distorted spacetimes. In detail we discuss only those distortions that are matched to the corresponding interior matter-filled solution in Section 6. Here we construct interior solutions of the Einstein–Cartan field equations, which are matched to the Volterra defect spacetimes, and the resulting matter distributions are interpreted as cosmic strings and cosmic dislocations.

For the sake of notational compactness, we use at the same time Cartesian coordinates $\{t, x, y, z\}$

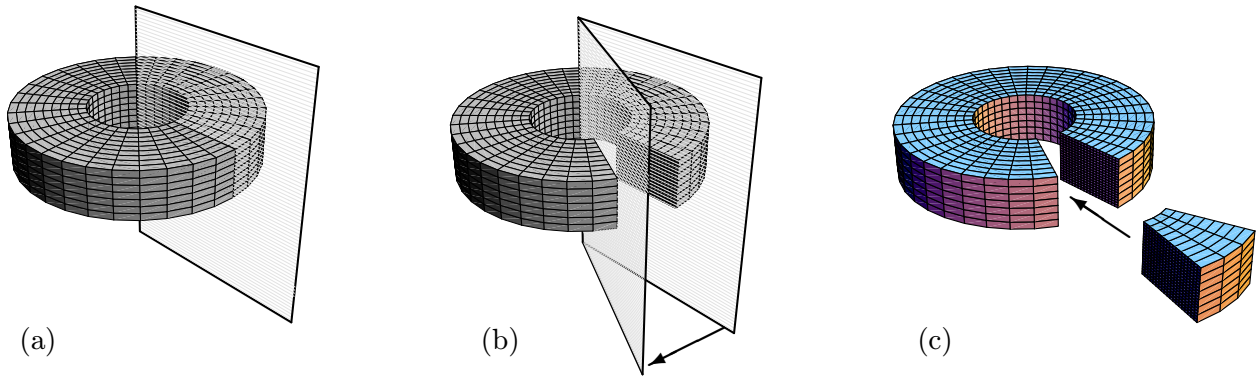

Figure 1: The Volterra process for the wedge disclination (order 6). (a) Cut hollow cylinder at a half two-plane. (b) Rotate lips. (c) Add missing material and weld lips together

and cylindrical coordinates $\{t, r, \phi, z\}$. For tensors and tensor-valued forms we sometimes suppress indices and use a self-evident matrix notation (indicated by boldface types) instead. Greek letters $\alpha, \beta, \dots = 0, 1, 2, 3$ will be used for anholonomic indices and Latin letters $i, j, \dots = 0, 1, 2, 3$ denote holonomic indices. In case of doubt, anholonomic indices are marked by a hat.

The symbol \wedge denotes the exterior product sign. The frame (vector basis) is named $e_\alpha = e^i{}_\alpha \partial_i$, the coframe (one-form basis) $\omega^\beta = e_j{}^\beta dx^j$; then we have $e_\alpha \lrcorner \omega^\beta = \delta_\alpha^\beta$, where \lrcorner denotes the interior product. The basis will be chosen *orthonormal*, i.e. $g = o_{\alpha\beta} \omega^\alpha \otimes \omega^\beta$ with $o_{\alpha\beta} := \text{diag}(-+++)$. Starting with the (metric) volume four-form $\eta := \omega^0 \wedge \omega^1 \wedge \omega^2 \wedge \omega^3$, we can successively define the η -basis for forms according to $\eta_\alpha := e_\alpha \lrcorner \eta$, $\eta_{\alpha\beta} := e_\beta \lrcorner \eta_\alpha$, $\eta_{\alpha\beta\gamma} := e_\gamma \lrcorner \eta_{\alpha\beta}$, $\eta_{\alpha\beta\gamma\delta} := e_\delta \lrcorner \eta_{\alpha\beta\gamma}$. We will also make use of the short-hand notation $e^\alpha := o^{\alpha\beta} e_\beta$ and $\omega_\alpha := o_{\alpha\beta} \omega^\beta$. The (Hodge) star operator will be denoted by $*$. We use geometrized units with $c = 8\pi G = 1$.

2 Gauge structure: From Euclid to Poincaré

A gravitational theory encompassing the equivalence principle is most conveniently described in terms of the geometry of spacetime. In this framework gravity is synonymous with some sort of deformation of spacetime.¹

Mass and spin are “gravitational currents”, which in turn are intimately connected with the Poincaré group. From a gauge-theoretic perspective one would a priori expect this group to be the local gauge group of gravity.

Taking the elasticity picture seriously, it is of interest to systematically study simple elastic deformations of spacetime and the corresponding global geometries and local sources. To this end we generalize the Volterra process to four-dimensional spacetime.

2.1 The generalized Volterra process

In the year 1907 Vito Volterra published an extensive article dedicated to the study of elastic deformations of multiply-connected, solid, three-dimensional objects [17]. His leitmotif was to take—as a prototype of such an object—a hollow cylinder made out of elastic material and cut it

¹The view that gravity is an expression of spacetime elasticity was adopted by Sakharov [29] who argued that the “metric elasticity” could be explained by quantum fluctuations of the vacuum. Here we follow the continuum mechanics analogy, but we do not pursue the search for a microscopic explanation of spacetime elasticity.

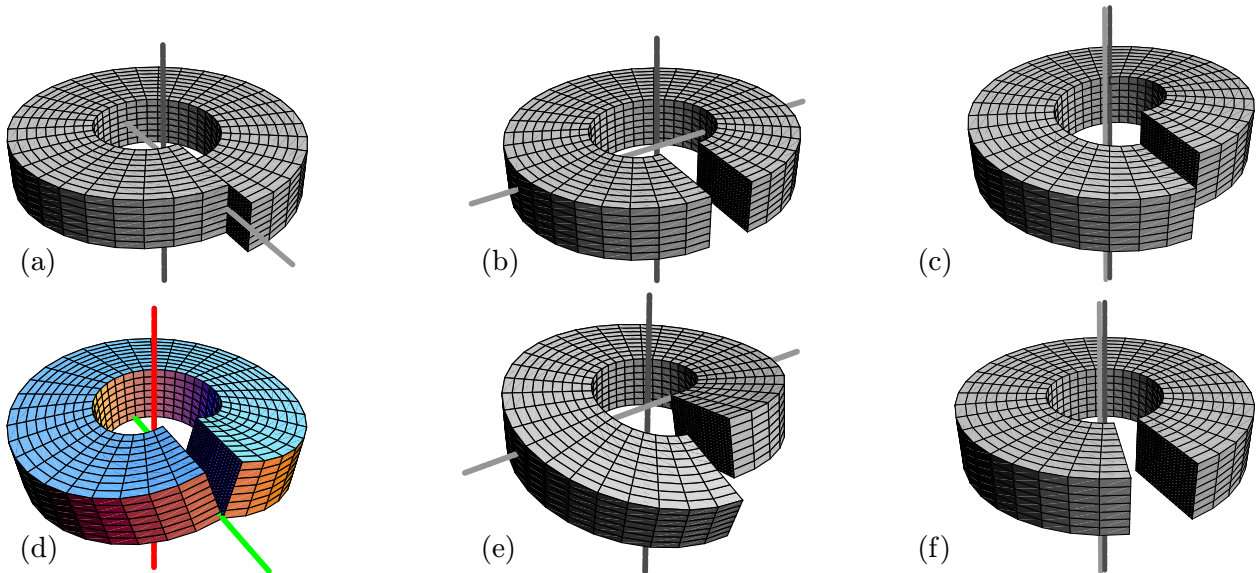

Figure 2: The six Volterra distortions. (a)–(c) Dislocations (order one to three). (d)–(f) Disclinations (order four to six)

at a half two-plane, e.g. at $\phi = 0$ (using cylindrical coordinates $\{r, \phi, z\}$, the cylinder is taken to be oriented along the z -axis), thereby destroying its multiple connectedness. Then take the two lips that have been separated by the cut and translate and rotate them against each other. Finally, after eventually removing superfluous or adding missing material, weld the two planes together again, see Fig. 1. This cutting and welding process is called the *Volterra process*.

The Volterra process, by construction, yields six different kinds of objects, see Fig. 2, which belong to the six degrees of freedom of the proper group of motion in \mathbb{R}^3 , the Euclidean group $SO(3) \rtimes T(3)$. Volterra called the resulting configurations *distortions of order one to six*. The distortions belonging to the translational subgroup $T(3)$ and the rotational subgroup $SO(3)$ are called *dislocations* and *disclinations*, respectively.

When lifting the Volterra process from 3 to $3 + 1$ dimensions, it is clear that instead of creating distorted hollow cylinders out of undistorted ones, the basic notion must be to ‘distort’ Minkowski spacetime into different Riemann–Cartan geometries. The group that takes the place of $SO(3) \rtimes T(3)$ is evidently the Poincaré group $P(10) = SO(1, 3) \rtimes T(4)$ with its 6 rotational and 4 translational parameters corresponding to the proper orthochronous Lorentz subgroup $SO(1, 3)$ and the translational subgroup $T(4)$, respectively. Adopting the language of the theory of elasticity, we may say that Minkowski spacetime will be deformed by 6 disclinations and 4 dislocations into 10 differently structured Riemann–Cartan spacetimes. It will turn out that these are locally flat and uncurved, but contain—as expected—topological defects represented by singular lines.

To arrive at an accurate description of the Volterra process, we must take a closer look at the cut that precedes the deformation. In an n -dimensional manifold, this cut is constructed in such a way that it separates two half $(n - 1)$ -dimensional hyperspaces, the *lips* of the cut, ending at an $(n - 2)$ -dimensional hyperspace, which will be denoted as the *defect region*. This name is justified because the defect region has to be excluded from the spacetime manifold, in analogy to the interior region of Volterra’s hollow cylinder. The two-plane perpendicular to the defect will be called the *supporting plane* of the distortion. It will carry translational and rotational holonomy.

In a $(3 + 1)$ -dimensional spacetime, there are two situations, which are distinct in principle: the intrinsic metric of the supporting plane may carry Riemannian (spacelike) or Lorentzian signature. In the first case, the respective distortions are said to be *space-supported*, in the latter case they are called *space- and time-supported*. Of course, the space- and time-supported distortions have no analogy in the theory of elasticity.

2.2 Distorting spacetime by gauging the Poincaré group

In the theory of elasticity, the conventional approach to describe the mechanics of an elastic deformation is to displace the point \mathbf{x} of some unstressed body by an amount $\mathbf{u}(\mathbf{x})$. Thus the point with coordinates \mathbf{x}' of the deformed body is related to the initial state by

$$\mathbf{x}' = \mathbf{x} + \mathbf{u}(\mathbf{x}) ,$$

and $\mathbf{u}(\mathbf{x})$ is called the *displacement field* of the deformation. With the Volterra process in mind, the deformation can be described more generally by saying that the Euclidean group $SO(3) \rtimes T(3)$ acts *locally* on the undeformed state, i.e.

$$\mathbf{x}' = \mathcal{R}(\mathbf{x})\mathbf{x} + \mathcal{T}(\mathbf{x}) , \tag{1}$$

where $\mathcal{T} \in T(3)$ and $\mathcal{R} \in SO(3)$.

Conventionally, the theory of elasticity is formulated by means of differential geometric tools [20, 30, 31]. The suggestive form of (1) points to a more recent approach, namely a $SO(3) \rtimes T(3)$ gauge theory of solid continua containing defects [32–36], which will allow the generalizations envisioned very intuitively (a corresponding task in the context of $2 + 1$ dimensional gravity is investigated in the work by Kohler [15, 16]): we can, in a natural way, adapt the results from elasticity to a theory of gravity by taking the Poincaré group $P(10)$ as a gauge group acting locally on Minkowski spacetime M_4 . In essence, we are developing an *active* Poincaré gauge theory. The reason why we select the Poincaré group is its prominent rôle as a spacetime symmetry group in special relativity. Moreover, both mass and spin, the corresponding matter currents, are known to exist in nature.

Consequently, our starting point is an M_4 with global coordinate cover $\mathbf{x} = \{x^0, x^1, x^2, x^3\}$. In analogy to (1), we express the local action of the Poincaré group $P(10)$ by the operation

$$\mathbf{x}' = \mathcal{P}(\mathbf{x})\mathbf{x} := \mathcal{L}(\mathbf{x})\mathbf{x} + \mathcal{T}(\mathbf{x}) \tag{2}$$

with a local Lorentz boost $\mathcal{L}(\mathbf{x})$ and a local translation $\mathcal{T}(\mathbf{x})$. The gauge construction will become most transparent if we introduce the following Möbius type matrix representation [37–40]: in the five-dimensional hyperplane $\tilde{\mathbb{R}}^4 := \{\tilde{\mathbf{x}} := (\mathbf{x}, 1)^t \in \mathbb{R}^5\}$, the group action (2) can be written

$$\tilde{\mathbf{x}}' = \mathcal{P}\tilde{\mathbf{x}} = \begin{pmatrix} \mathcal{L} & \mathcal{T} \\ 0 & 1 \end{pmatrix} \begin{pmatrix} \mathbf{x} \\ 1 \end{pmatrix} = \begin{pmatrix} \mathcal{L}\mathbf{x} + \mathcal{T} \\ 1 \end{pmatrix} . \tag{3}$$

Here and in the rest of the article it is understood that operations always act locally, i.e. $\mathcal{L} = \mathcal{L}(\mathbf{x})$, and so on. Now the standard gauge approach à la Yang–Mills can be applied [41]. We define the connection

$$\tilde{\mathbf{\Gamma}} = \begin{pmatrix} \mathbf{\Gamma}^{(L)} & \mathbf{\Gamma}^{(T)} \\ 0 & 0 \end{pmatrix} \tag{4}$$

that transforms inhomogeneously into

$$\tilde{\Gamma}' = \mathcal{P}\tilde{\Gamma}\mathcal{P}^{-1} - d\mathcal{P}\mathcal{P}^{-1} \quad (5)$$

under $P(10)$. Explicitly, we find the $SO(1,3)$ -algebra-valued connection one-form, the *Lorentz connection*,

$$\Gamma^{(L)'} = \mathcal{L}\Gamma^{(L)}\mathcal{L}^{-1} - (d\mathcal{L})\mathcal{L}^{-1}, \quad (6)$$

compensating for the local action of the Lorentz sector, and the \mathbb{R}^4 -valued connection one-form, the *translation connection*,

$$\Gamma^{(T)'} = \mathcal{L}\Gamma^{(T)} - D\mathcal{T} = \mathcal{L}\Gamma^{(T)} - d\mathcal{T} - \Gamma^{(L)'}\mathcal{T}, \quad (7)$$

compensating for the local action of $T(4)$. Here we have used the notation $D = d + \Gamma^{(L)'} \wedge$.

The transformation behaviour (7) of the translation part $\Gamma^{(T)}$ of the connection is inhomogeneous and hence, in particular, nontensorial. For this reason, $\Gamma^{(T)}$ cannot be taken as coframe of the target space. There is, however, a trick to circumvent this situation [40]: the *soldering one-form*

$$\omega := \Gamma^{(T)'} + D\xi = \Gamma^{(T)'} + d\xi + \Gamma^{(L)'}\xi, \quad (8)$$

with some vector-valued zero-form ξ , shows the ‘right’ transformation behaviour, namely that of a vector-valued one-form. The rôle of ξ , sometimes called the *Poincaré coordinate* [42], or *generalized Higgs field* [43], is not completely clear, see [40] and the literature given there. In contrast to the authors of [40], who choose $D\xi = 0$, we impose the condition $\xi = \mathbf{x}$, and find

$$\omega = \Gamma^{(T)} + D\mathbf{x} = \Gamma^{(T)} + d\mathbf{x} + \Gamma^{(L)}\mathbf{x}, \quad (9)$$

which can be regarded as the exterior covariant derivative $\tilde{D} := d + \tilde{\Gamma} \wedge$ acting on $\tilde{\mathbf{x}}$:

$$\tilde{\omega} := \tilde{D}\tilde{\mathbf{x}} = \begin{pmatrix} \Gamma^{(T)} + d\mathbf{x} + \Gamma^{(L)}\mathbf{x} \\ 0 \end{pmatrix}. \quad (10)$$

The soldering forms (9) make up an orthonormal coframe, which yields

$$g = g_{ij} dx^i \otimes dx^j := o_{\alpha\beta} \omega^\alpha \otimes \omega^\beta, \quad (11)$$

with $o_{\alpha\beta} := \text{diag}(-+++)$. Finally, the torsion two-form \mathbf{T} is defined by the structure equation

$$\mathbf{T} = d\omega + \Gamma^{(L)} \wedge \omega = \mathbf{R}\mathbf{x} + d\Gamma^{(T)} + \Gamma^{(L)} \wedge \Gamma^{(T)}, \quad (12)$$

where \mathbf{R} denotes the curvature two-form defined by the structure equation

$$\mathbf{R} = d\Gamma^{(L)} + \Gamma^{(L)} \wedge \Gamma^{(L)}. \quad (13)$$

2.3 Burgers vector and Frank matrix

We have already pointed to the fact that the distorted spacetime manifolds will be *locally* flat and uncurved. In order to detect the effect of the generalized Volterra process, we compute the holonomy transformation, usually considered in the loop space formulation of gauge theories [44]. (See also [45] in the context of cosmic strings.)

For our purpose, it is sufficient to think of a vierbein, transported along a closed path S around the line-like defect region. More precisely, S is the image in U_4 of a closed path² in the undistorted M_4 under the mapping (2). As a result of this parallel transport, we will detect translational holonomy, characterized by the *Burgers vector* $\mathcal{B} \in T(4)$, and rotational holonomy, described by $\mathcal{G} \in SO(1,3)$, the *Frank matrix*.³ In other words, after parallel transport along S , the vierbein will have been subject to an affine transformation—the above-mentioned holonomy transformation—namely a translation \mathcal{B} and a “rotation” \mathcal{G} .

The Burgers vector is defined to be the contour integral of the coframe [34, p. 1372]

$$\mathcal{B} \equiv \oint_S \omega .$$

The contour integral of the Minkowski coframe $d\mathbf{x}$ vanishes. Thus, if we restrict ourselves to dislocations, characterized by $\mathcal{L} = \mathbf{1}$ and consequently $\Gamma^{(L)} = 0$, we find from (9) for the Burgers vector

$$\mathcal{B} = \oint_S \Gamma^{(T)} = - \oint_S d\mathcal{T} . \quad (14)$$

In order to compute the Frank matrix \mathcal{G} of the distorted spacetime, we start from the Lorentz connection $\Gamma^{(L)}$ as defined in (6). The Frank matrix is defined as the Lorentz connection integrated along the path S , resulting in an element of the Lorentz group. Explicitly we have

$$\mathcal{G} = \mathcal{P} \exp \left\{ - \oint_S \Gamma^{(L)} \right\} , \quad (15)$$

where $\mathcal{P} \exp$ denotes the path-ordered exponential, which reflects the noncommutative structure of the Lorentz group $SO(1,3)$. Full information on the rotational holonomy is only contained in the Frank matrix. The deficit angle $\Delta\phi$, frequently used to describe disclinations in solids, is the fixed parameter value of \mathcal{G} , but, of course, we lose information on the two-plane in which \mathcal{G} acts if we only give the deficit angle $\Delta\phi$.

3 Volterra distortions

Before we can explicitly construct the Volterra distorted spacetimes, we must specify the geometry by picking the two-plane supporting the defect. In the present section, we study space-supported distortions and, using Cartesian coordinates $\mathbf{x} = \{x^0, x^1, x^2, x^3\} = \{t, x, y, z\}$ for the undistorted M_4 , we choose the x - y plane, conveniently parametrized by the radius $r = \sqrt{x^2 + y^2}$ and the polar angle $\phi = \arctan y/x$.

²Very similarly, we can take S to be the *development* [46] in M_4 of a curve which is closed in U_4 .

³Göckeler and Schücker [47] use the name *parallel transporter* for \mathcal{G} . However, to be consistent we would have to use something like “translational parallel transporter” for the Burgers vector. Therefore, we have adapted the name Frank matrix, which is the four-dimensional analogue of the Frank vector of a solid-state disclination.

Table 1: Dislocations and disclinations characterized by the geometric objects that are introduced in Section 2.

| | Dislocation of order i | Disclination of order a |
|------------------------|---|--|
| Rotation | $\mathcal{L} = \mathbf{1}$ | $\mathcal{L} = \exp\left(\Phi/(2\pi)\phi\mathbf{l}_a\right)$ |
| Translation | $\mathcal{T} = J/(2\pi)\phi\mathbf{e}_i$ | $\mathcal{T} = \mathbf{0}$ |
| Lorentz connection | $\Gamma^{(L)} = \mathbf{0}$ | $\Gamma^{(L)} = -d\mathcal{L}\mathcal{L}^{-1}$ |
| Translation connection | $\Gamma^{(T)} = -d\mathcal{T}$ | $\Gamma^{(T)} = \mathbf{0}$ |
| Soldering one-form | $\omega = d\mathbf{x} - d\mathcal{T}$ | $\omega = d\mathbf{x} + \Gamma^{(L)}\mathbf{x} = d\mathbf{x} - d\mathcal{L}\mathcal{L}^{-1}\mathbf{x}$ |
| Burgers vector | $\mathcal{B} = \oint (d\mathbf{x} - d\mathcal{T}) = \frac{J}{2\pi}\mathbf{e}_i$ | $\mathcal{B} = \oint (d\mathbf{x} - d\mathcal{L}\mathcal{L}^{-1}\mathbf{x})$ |
| Frank matrix | $\mathcal{G} = \mathbf{0}$ | $\mathcal{G} = \mathcal{P} \exp \oint -d\mathcal{L}\mathcal{L}^{-1}$ |

As we are assuming Cartesian coordinates for M_4 , we have $\Gamma^{(L)} = \Gamma^{(T)} = \mathbf{0}$ in (6) and (7). Therefore we can omit primes for the transformed gauge connections, implying that whenever connection one-forms $\Gamma^{(L)}$ or $\Gamma^{(T)}$ show up, they belong to the *distorted* spacetime U_4 .

The notion that leads to the fundamental Volterra distortions is the following. *Dislocations*, i.e. translational distortions, are defined by $\mathcal{L} = \mathbf{1}$ and $\mathcal{T} = J/(2\pi)\phi\mathbf{e}_i$, where $\{\mathbf{e}_i | 0 \leq i \leq 3\}$ are the generators of the translation group. The constant J parametrizes the dislocation strength. Using Volterra's original terminology, we may say that \mathcal{T} , if defined in such a way, generates a dislocation *of order i* . Evaluating (6), we find that the Lorentz connection one-form vanishes identically, $\Gamma^{(L)} = \mathbf{0}$, i.e. spacetime remains globally flat. From (7) the translation connection is $\Gamma^{(T)} = -d\mathcal{T}$ and the orthonormal coframe (9) evaluates to

$$\omega = d\mathbf{x} + \Gamma^{(T)} = d\mathbf{x} - d\mathcal{T} . \quad (16)$$

Analogously we define rotational distortions or *disclinations*. Here we have $\mathcal{T} = \mathbf{0}$ and $\mathcal{L} = \exp\left(\Phi/(2\pi)\phi\mathbf{l}_a\right)$, with constant Φ , the disclination strength, and the generators $\{\mathbf{l}_a | 4 \leq a \leq 9\}$ of the Lorentz group $SO(1,3)$. The boost \mathcal{L} belongs to a disclination *of order a* . The translation connection $\Gamma^{(T)}$ vanishes and (6) evaluates to

$$\Gamma^{(L)} = -d\mathcal{L}\mathcal{L}^{-1} . \quad (17)$$

We have collected the geometric objects characterizing all space-supported dislocations and disclinations in Table 1. Note that our definition of the order of the Volterra distortions is such that orders one to six correspond to the classical Volterra distortions [17]. Order zero, the time dislocation, and orders seven to nine, the boost disclinations, are due to the generalization to spacetime.

3.1 Dislocations

With Table 1 and formula (11), the line elements of the four space-supported Volterra dislocations are computed straightforwardly. The result is given in Table 2. If the Burgers vector is contained in the defect region, the defect corresponds to a *screw dislocation*, otherwise, i.e. the Burgers vector

Table 2: Line elements for the space-supported dislocations

| Order | Line element |
|-------|--|
| 0 | $ds^2 = -\left(dt + \frac{\Theta^0}{2\pi}d\phi\right)^2 + dr^2 + r^2d\phi^2 + dz^2$ |
| 1 | $ds^2 = -dt^2 + dx^2 + dy^2 + dz^2 + 2\frac{\Theta^1}{2\pi r^2} dx (x dy - y dx) + \left(\frac{\Theta^1}{2\pi r^2}\right)^2 (x dy - y dx)^2$ |
| 2 | $ds^2 = -dt^2 + dx^2 + dy^2 + dz^2 + 2\frac{\Theta^2}{2\pi r^2} dy (x dy - y dx) + \left(\frac{\Theta^2}{2\pi r^2}\right)^2 (x dy - y dx)^2$ |
| 3 | $ds^2 = -dt^2 + dr^2 + r^2d\phi^2 + \left(dz + \frac{\Theta^3}{2\pi}d\phi\right)^2$ |

is perpendicular to the defect region, it is referred to as an *edge dislocation*. Thus we have two screw dislocations (orders zero and three) and two edge dislocations (orders one and two). The time dislocation (order zero) is due to the generalization to spacetime.

By using (12), we can compute the torsion two-forms of the four Volterra dislocations. If we take, for instance, the time dislocation (order zero), we find

$$\begin{aligned}
 T^0 &= d\omega^0 = -\frac{\Theta^0}{2\pi} d(\partial_x\phi dx + \partial_y\phi dy) = -\frac{\Theta^0}{2\pi} (-\partial_y\partial_x\phi + \partial_x\partial_y\phi) dx \wedge dy \\
 &= -\Theta^0 \delta^2(x, y) dx \wedge dy,
 \end{aligned} \tag{18}$$

where $\delta^2(x, y)$ is the two-dimensional delta distribution supported by the x - y plane. Here, we have basically used the identity $d^2\phi \equiv d^2 \arctan y/x = 2\pi\delta^2(x, y) dx \wedge dy$. All other torsion components vanish. The corresponding computation for the remaining three dislocations is done in complete analogy.

3.2 Disclinations

Let us investigate, as the prototype of a disclination, some details of the axial *wedge* disclination (order six). It is characterized by the local rotation

$$\mathcal{L} = \begin{pmatrix} 1 & 0 & 0 & 0 \\ 0 & \cos\left(\frac{\Phi^6}{2\pi}\phi\right) & -\sin\left(\frac{\Phi^6}{2\pi}\phi\right) & 0 \\ 0 & \sin\left(\frac{\Phi^6}{2\pi}\phi\right) & \cos\left(\frac{\Phi^6}{2\pi}\phi\right) & 0 \\ 0 & 0 & 0 & 1 \end{pmatrix} \tag{19}$$

in the x - y plane. After some elementary algebra, (17) yields

$$\Gamma^{(L)} = \begin{pmatrix} 0 & 0 & 0 & 0 \\ 0 & 0 & 1 & 0 \\ 0 & -1 & 0 & 0 \\ 0 & 0 & 0 & 0 \end{pmatrix} \frac{\Phi^6}{2\pi r^2} (x dy - y dx) \tag{20}$$

for the Lorentz connection. By using (15), we compute the Frank matrix of an arbitrary loop S ,

$$\mathcal{G} = \mathcal{P} \exp \left\{ - \oint_{\phi=0}^{2\pi} \mathbf{\Gamma}^{(L)} \right\} = \begin{pmatrix} 1 & 0 & 0 & 0 \\ 0 & \cos \Phi^6 & \sin \Phi^6 & 0 \\ 0 & -\sin \Phi^6 & \cos \Phi^6 & 0 \\ 0 & 0 & 0 & 1 \end{pmatrix}, \quad (21)$$

corresponding to the deficit angle $\Delta\phi = \Phi^6$. These results are very intuitive if one remembers the usual interpretation of the geometric objects involved: the connection $\mathbf{\Gamma}^{(L)}$ is a Lorentz-*algebra*-valued one-form describing *infinitesimal* parallel transport of a vector frame. The Frank matrix \mathcal{G} takes its values in the Lorentz *group* corresponding to parallel transport of a vector frame along the finite path S .

The orthonormal coframe (9) becomes

$$\begin{aligned} \omega^0 &= dt \\ \omega^1 &= dx + \frac{\Phi^6}{2\pi} \frac{y}{r^2} (x dy - y dx) \\ \omega^2 &= dy - \frac{\Phi^6}{2\pi} \frac{x}{r^2} (x dy - y dx) \\ \omega^3 &= dz . \end{aligned} \quad (22)$$

The curvature two-form may be calculated from the structure equation (13). With the Lorentz connection (21) and a computation similar to the one resulting in (18), the nonvanishing components of the curvature two-form turn out to be

$$R^1{}_2 = -R^2{}_1 = \Phi^6 \delta^2(x, y) dx \wedge dy . \quad (23)$$

The curvature of the spacetimes corresponding to the remaining disclinations is calculated straightforwardly; the result is obvious and therefore not given explicitly. The line elements corresponding to the six Volterra disclinations are given in Table 3.

4 Space- and time-supported distortions

In order to arrive at a description of space- and time-supported distortions, we must (i) specify the plane that will support the distortions, and (ii) consider how to adapt the Volterra process. Starting off with (i), we choose the t - z plane as support. The structure of the space- and time-supported Volterra process is worked out most clearly in terms of the two new parameters

$$\tau \equiv \sqrt{z^2 + t^2} \quad \text{and} \quad \zeta \equiv \arctan(t/z), \quad (24)$$

which will take the place of the radial coordinate r and the angular coordinate ϕ , respectively.

In analogy to what has been done to construct space-supported distortions, we shall obtain *space- and time-supported dislocations* by choosing a local translation, which is proportional to ζ , the ‘‘angle’’ in the supporting two-plane, and *space- and time-supported disclinations* if we use a local rotation (or, more generally, a Lorentz boost) proportional to ζ .

Table 3: Line elements for the space-supported disclinations

| Order | Line element |
|-------|---|
| 4 | $ds^2 = -dt^2 + dx^2 + dy^2 + dz^2$ $+ 2\frac{\Phi^4}{2\pi r^2}(z dy - y dz)(x dy - y dx) + \left(\frac{\Phi^4}{2\pi r^2}\right)^2 (y^2 + z^2)(x dy - y dx)^2$ |
| 5 | $ds^2 = -dt^2 + dx^2 + dy^2 + dz^2$ $+ 2\frac{\Phi^5}{2\pi r^2}(z dx - x dz)(x dy - y dx) + \left(\frac{\Phi^5}{2\pi r^2}\right)^2 (x^2 + z^2)(x dy - y dx)^2$ |
| 6 | $ds^2 = -dt^2 + dr^2 + \left(1 - \frac{\Phi^6}{2\pi}\right)^2 r^2 d\phi^2 + dz^2$ |
| 7 | $ds^2 = -dt^2 + dx^2 + dy^2 + dz^2$ $- 2\frac{\Phi^7}{2\pi r^2}(y dt + t dy)(x dy - y dx) + \left(\frac{\Phi^7}{2\pi r^2}\right)^2 (y^2 - t^2)(x dy - y dx)^2$ |
| 8 | $ds^2 = -dt^2 + dx^2 + dy^2 + dz^2$ $- 2\frac{\Phi^8}{2\pi r^2}(x dt + t dx)(x dy - y dx) + \left(\frac{\Phi^8}{2\pi r^2}\right)^2 (x^2 - t^2)(x dy - y dx)^2$ |
| 9 | $ds^2 = -\left(dt + \frac{\Phi^9}{2\pi} z d\phi\right)^2 + dr^2 + r^2 d\phi^2 + \left(dz + \frac{\Phi^9}{2\pi} t d\phi\right)^2$ |

Presently, we shall restrict our study of space- and time-supported distortions to two cases. The remaining defects can be constructed in very much the same way. To start with, we consider the displacement field \mathcal{T} of the time-dislocation, which must be adapted to the supporting z - t plane. This is achieved by the displacement

$$\mathcal{T} = \frac{\chi_0}{2\pi} \delta^i_0 \arctan(t/z) \mathbf{e}_i = \chi_0 \zeta \mathbf{e}_0, \quad (25)$$

where $\chi_0 = \text{constant}$. Having specified the appropriate gauge transformation, all geometric quantities are computed as before. This yields the orthonormal coframe

$$\begin{aligned} \omega^0 &= dt - \frac{\chi_0}{2\pi\tau^2}(z dt - t dz) = dt - \frac{\chi_0}{2\pi} d\zeta \\ \omega^1 &= dx \\ \omega^2 &= dy \\ \omega^3 &= dz, \end{aligned} \quad (26)$$

the line element

$$ds^2 = -\left[dt + \frac{\chi_0}{2\pi\tau^2}(tdz - zdt)\right]^2 + dr^2 + r^2 d\phi^2 + dz^2, \quad (27)$$

and the Burgers vector

$$\mathcal{B} = \chi_0 \mathbf{e}_0. \quad (28)$$

It should not be surprising that the Burgers vector does not seem to depend on the support of the distortion, since this information has already been used to choose the curve S in (14) to lie

in the supporting plane, i.e. the t - z plane. The torsion two-form, by (12), has the only nontrivial component

$$T^0 = d\omega^0 = -\chi_0 \delta^2(z, t) dz \wedge dt, \quad (29)$$

where we have used $d^2 \arctan t/z = 2\pi \delta^2(z, t) dz \wedge dt$. By evaluating the structure equation (13) we find that the curvature two-form \mathbf{R} vanishes: the distorted spacetime remains globally flat. The present space- and time-supported dislocation is closely related to the corresponding space-supported defect: the torsion two-form (29) of the former arises by formally replacing (x, y) by (t, z) in the expression (18) for the torsion of latter. This correspondence clearly reflects the change of the support from the x - y plane to the t - z plane.

The space- and time-supported dislocation in the z -direction is characterized by the local translation

$$\mathcal{T} = \frac{\chi_3}{2\pi} \delta^i{}_3 \arctan e_i = \frac{\chi_3}{2\pi} \zeta e_3 \quad (30)$$

resulting in a globally flat spacetime with the orthonormal coframe

$$\begin{aligned} \omega^0 &= dt \\ \omega^1 &= dx \\ \omega^2 &= dy \\ \omega^3 &= dz - \frac{\chi_3}{2\pi\tau^2} (z dt - t dz) = dz - \frac{\chi_3}{2\pi} d\zeta, \end{aligned} \quad (31)$$

which corresponds to the line element

$$ds^2 = -dt^2 + dr^2 + r^2 d\phi^2 + \left[dz + \frac{\chi_3}{2\pi\tau^2} (tdz - zdt) \right]^2. \quad (32)$$

The Burgers vector and the torsion two-form read

$$\mathcal{B} = \chi_3 e_3 \quad (33)$$

and

$$T^3 = d\omega^3 = -\chi_3 \delta^2(z, t) dz \wedge dt, \quad (34)$$

respectively. Again, the Burgers vector has the same components as in the case of the space-supported axial dislocation. The metrics () and (), due to the Lorentzian signature of the support, are nonstatic. Although the geometry has been analyzed here, a physical interpretation must rely on an interior solution, compare the Appendix.

5 Field equations and matching conditions

5.1 Field equations

Formulated in the language of exterior differential calculus, the field equations of EC theory read [48, 49]:

$$\frac{1}{2} \eta_{\alpha\beta\gamma} \wedge R^{\beta\gamma} = \kappa \Sigma_\alpha, \quad (35)$$

$$\frac{1}{2} \eta_{\alpha\beta\gamma} \wedge T^\gamma = \kappa \tau_{\alpha\beta}. \quad (36)$$

On the left-hand sides, we have the curvature two-form $R^{\alpha\beta}$ and the torsion two-form T^α . The matter currents on the right-hand sides are represented by the canonical energy–momentum three-form Σ_α and the spin three-form $\tau_{\alpha\beta}$. The Einsteinian gravitational constant is denoted by κ . The field equations (35) and (36) may be cast into an ‘effective’ Einsteinian form [6]. It has been argued [50, 51] that the corresponding ‘effective’ energy–momentum current should replace the symmetric energy–momentum current of GR when questions such as energy conditions are investigated. More recent investigations [52] come to a similar conclusion.

In a static situation, the most natural procedure to find (physically sensible) solutions to the field equations (35) and (36) of EC theory is to first specify the matter currents Σ_α and $\tau_{\alpha\beta}$ which are then put into the field equations, thereby determining the geometry of spacetime, i.e. the quantities $R^{\alpha\beta}$ and T^α . For obvious reasons, this is not a viable procedure for our present investigation. Nevertheless, a matter model is indispensable for a physical interpretation of the spacetimes considered. As the most prominent example of such a matter model, we define matter currents of a *spin fluid* by using the quite general hyperfluid paradigm by Obukhov and Tresguerres [53] (see also [54]), which specializes to

$$\Sigma_\alpha = \epsilon u_\alpha u + p(\eta_\alpha + u_\alpha u) - 2u^\beta \dot{S}_{\alpha\beta} u, \quad (37)$$

$$\tau^{\alpha\beta} = S^{\alpha\beta} u \quad (38)$$

for the matter currents of a spin fluid. The flow three-form u must be normalized, $*u \wedge u = -\eta$, and is related to the usual velocity four-vector $u = u^\alpha e_\alpha$ by

$$u^\alpha = e^\alpha \lrcorner (*u). \quad (39)$$

The rest-energy density ϵ , the spin density $S_{\alpha\beta}$, and the particle density ρ are related by an equation of state $\epsilon = \epsilon(\rho, S_{\alpha\beta})$ that must be chosen appropriately.

5.2 Matching conditions

The AKP matching conditions of the EC theory determine under which conditions a given matter distribution may be matched consistently—i.e. such that the field equations (35) and (36) are fulfilled in the distributional sense—to a vacuum solution.

The original formulation of Arkuszewski, Kopczyński and Ponomarev [55], see also Chmielewski [56], takes recourse to the coordinate components of the geometrical and dynamical objects involved. In other words, everything is referred to a *natural* frame ∂_i or coframe dx^j , respectively. Then, instead of the coframe, the components of the metric $g_{ij} = e_i^\alpha e_j^\beta o_{\alpha\beta}$, together with those of the contortion $K_{kij} = e_i^\alpha e_j^\beta K_{k\alpha\beta}$, enter the scene. Torsion and contortion are interrelated according to $T^\alpha = K^\alpha{}_\beta \wedge \omega^\beta$ with $K^\alpha{}_\beta = K_k{}^\alpha{}_\beta dx^k$. The connection can be written as the sum of the Christoffel symbol and a contortion part:

$$\Gamma_{ij}{}^k = \Gamma_{ij}^{\{\}k} - K_{ij}{}^k. \quad (40)$$

The energy–momentum and spin three-forms, in components with respect to the η -basis, read

$$\Sigma_\alpha = \Sigma_\alpha{}^k \eta_k, \quad \tau_{\alpha\beta} = \tau_{\alpha\beta}{}^k \eta_k, \quad (41)$$

where $\Sigma_\alpha{}^k$ and $\tau_{\alpha\beta}{}^k$ are the canonical tensors of energy-momentum and spin, respectively.

Let us suppose that there exists a coordinate x defining locally a hypersurface \mathcal{S} by the equation $x = 0$, such that matter is bound to the region $x < 0$. Furthermore, we define the normalized vector field with components $n_i = \partial_i x / |\nabla x|$ and the operator

$$h^i_j = \delta^i_j + n^i n_j, \quad (42)$$

projecting on hypersurfaces $x = \text{const.}$ For any geometric object T , we may use h^i_j to construct its projection on the hypersurface $x = \text{const.}$, which will be denoted by \bar{T} . We will also use the notation $T|_{\pm} \equiv \lim_{x \rightarrow \pm 0} T$.

For a matter distribution, the components Σ_i^k and τ_{ij}^k of the energy–momentum tensor and the spin tensor are subject to the *junction conditions* [55]

$$n_k \Sigma_i^k|_{-} - n_i \bar{K}_{jkl} \bar{K}^{klj}|_{-} = 0 \quad (43)$$

and

$$n_k \tau_{ij}^k|_{-} = 0, \quad (44)$$

respectively. If the conditions (43) and (44) are fulfilled, then there exists a unique solution to the vacuum field equations, which is determined by the *boundary conditions*

$$g_{ij}|_{+} = g_{ij}|_{-} \quad (45)$$

and

$$\partial_x g_{ij}|_{+} = \partial_x g_{ij}|_{-} + 2K_{(ij)}^x / g^{xx}|_{-}, \quad (46)$$

restricting the components and the first derivatives of the metric tensor g_{ij} . Therefore the metric tensor is continuous across the bounding hypersurface, whereas its first derivatives with respect to the function x have a jump that is determined by the contortion components K_{ij}^k . This last fact clearly distinguishes the AKP matching conditions from the Lichnerowicz matching conditions of GR.

6 Extended matter sources

By generalizing the Volterra process to four-dimensional spacetime we have generated all possible vacuum geometries outside an infinitely long straight-line defect. In this section we shall find extended matter distributions producing the same exterior metrics as the Volterra processes zero, three, and six. The canonical energy–momentum tensor is assumed to take a string-like form satisfying the weak energy condition by construction. However, the metric energy–momentum tensor may be subject to stronger restrictions which put a limit on the strength of torsion [57].

6.1 Cosmic string analogue to a spinning particle in 2+1 dimensions

A point particle in (2+1)-dimensional gravity translates into an infinitely thin, straight cosmic string in (3+1)-dimensional spacetime. If the point particle is permitted to have spin, then the lift from 2+1 to 3+1 dimensions is nonunique, since the spin-tensor component is undetermined along

the additional spatial dimension. Thus, there are three physically distinct types of cosmic strings with spin [10].

Here we shall derive an interior solution, which corresponds to these three types of spinning line-like topological defects: the spinning cosmic string [58], the cosmic dislocation (twisted string) [10], and the cosmic string interacting with a gravitational wave. The interior spinning string solution [28] is a special case of this solution.

Matching of the solution to an exterior Einstein vacuum leads to the general exterior solution that was studied in detail in Ref. [10].

6.1.1 Geometry

Let the line element of spacetime be of the form

$$ds^2 = -[dt + M(r)d\phi]^2 + dr^2 + \rho(r)^2 d\phi^2 + [dz + C(r)d\phi]^2. \quad (47)$$

If $\rho(r) = r$ and $C(r) = M(r) = 0$, Eq. (47) reduces to the line element of Minkowski spacetime in terms of cylindrical coordinates.

Let us define a (pseudo-)orthonormal frame specified by the following one-form basis:

$$\begin{aligned} \omega^{\hat{0}} &= dt + M(r)d\phi \\ \omega^{\hat{1}} &= dr \\ \omega^{\hat{2}} &= \rho(r)d\phi \\ \omega^{\hat{3}} &= dz + C(r)d\phi. \end{aligned} \quad (48)$$

Let the nonvanishing components of the energy-momentum current be given as

$$\Sigma^{\hat{0}} = -\lambda \omega^{\hat{1}} \wedge \omega^{\hat{2}} \wedge \omega^{\hat{3}}, \quad \Sigma^{\hat{3}} = -\lambda \omega^{\hat{0}} \wedge \omega^{\hat{1}} \wedge \omega^{\hat{2}}, \quad (49)$$

where λ is a constant, in accordance with the homogeneity assumption. The spin three-form is assumed to have the only nonzero component

$$\begin{aligned} \tau^{\hat{1}\hat{2}} &= -\tau^{\hat{2}\hat{1}} = \sigma \eta^{\hat{0}} + \beta \eta^{\hat{3}} \\ &= -\sigma \omega^{\hat{1}} \wedge \omega^{\hat{2}} \wedge \omega^{\hat{3}} - \beta \omega^{\hat{0}} \wedge \omega^{\hat{1}} \wedge \omega^{\hat{2}}. \end{aligned} \quad (50)$$

Also β and σ are constants. Note that unlike the energy-momentum current, the components of the spin current are *not* boost-invariant along the axis of symmetry. Hence, if we define another Lorentz frame by a boost along the cylinder

$$\begin{pmatrix} \omega^{\hat{0}'} \\ \omega^{\hat{1}'} \\ \omega^{\hat{2}'} \\ \omega^{\hat{3}'} \end{pmatrix} = \begin{pmatrix} \gamma(v) & 0 & 0 & -v\gamma(v) \\ 0 & 1 & 0 & 0 \\ 0 & 0 & 1 & 0 \\ -v\gamma(v) & 0 & 0 & \gamma(v) \end{pmatrix} \begin{pmatrix} \omega^{\hat{0}} \\ \omega^{\hat{1}} \\ \omega^{\hat{2}} \\ \omega^{\hat{3}} \end{pmatrix},$$

then the spin three-form is given by

$$\begin{aligned} \tau^{\hat{1}'\hat{2}'} &= -\sigma' \omega^{\hat{1}'} \wedge \omega^{\hat{2}'} \wedge \omega^{\hat{3}'} - \beta' \omega^{\hat{0}'} \wedge \omega^{\hat{1}'} \wedge \omega^{\hat{2}'} \\ &= -\gamma(v)(\sigma - v\beta) \omega^{\hat{1}'} \wedge \omega^{\hat{2}'} \wedge \omega^{\hat{3}'} - \gamma(v)(\beta - v\sigma) \omega^{\hat{0}'} \wedge \omega^{\hat{1}'} \wedge \omega^{\hat{2}'} . \end{aligned}$$

From these relations it is clear that $\beta^2 - \sigma^2$ is an invariant under boosts along the cylinder. This quantity is interpreted quite naturally within the spin-fluid model of Sect. 5.1. The spin current (38) specializes to our ansatz (50) if the flow three-form and the spin density are given by $u = \gamma(v)(\eta^{\hat{0}} + v \eta^{\hat{3}})$ and $S^{\alpha\beta} = s \delta_1^{[\alpha} \delta_2^{\beta]}$, respectively. Therefore

$$\sigma = -\gamma(v) s, \quad \beta = \gamma(v) v s, \quad (51)$$

and the given invariant turns out to be the spin density s in the rest frame of the fluid,

$$s = \sqrt{\beta^2 - \sigma^2}. \quad (52)$$

6.1.2 Interior solution

For computational simplicity we define the zero-forms

$$\Omega(r) \equiv \kappa \sigma + \frac{M'}{2\rho} \quad \text{and} \quad \Upsilon(r) \equiv \kappa \beta - \frac{C'}{2\rho}. \quad (53)$$

The prime denotes a partial derivative with respect to r . According to the second field equation (36), the torsion two-form for the source (50) is given by

$$\begin{aligned} T^{\hat{0}} &= 2\kappa\sigma \eta^{\hat{0}\hat{3}} = -2\kappa\sigma \omega^{\hat{1}} \wedge \omega^{\hat{2}}, \\ T^{\hat{3}} &= -2\kappa\beta \eta^{\hat{0}\hat{3}} = 2\kappa\beta \omega^{\hat{1}} \wedge \omega^{\hat{2}}. \end{aligned} \quad (54)$$

The Einstein three-form computed from the metric (47) and the torsion (54) reads

$$\begin{aligned} G^{\hat{0}} &= \left(\frac{1}{\rho} (C'\Upsilon + M'\Omega - \rho'') + \Omega^2 + \Upsilon^2 \right) \omega^{\hat{1}} \wedge \omega^{\hat{2}} \wedge \omega^{\hat{3}} + 2\Omega\Upsilon \omega^{\hat{0}} \wedge \omega^{\hat{1}} \wedge \omega^{\hat{2}} - \Omega' \omega^{\hat{0}} \wedge \omega^{\hat{1}} \wedge \omega^{\hat{3}} \\ G^{\hat{1}} &= (-\Omega^2 + \Upsilon^2) \omega^{\hat{0}} \wedge \omega^{\hat{2}} \wedge \omega^{\hat{3}} \\ G^{\hat{2}} &= -\Omega' \omega^{\hat{1}} \wedge \omega^{\hat{2}} \wedge \omega^{\hat{3}} - \Upsilon' \omega^{\hat{0}} \wedge \omega^{\hat{1}} \wedge \omega^{\hat{2}} + (\Omega^2 - \Upsilon^2) \omega^{\hat{0}} \wedge \omega^{\hat{1}} \wedge \omega^{\hat{3}} \\ G^{\hat{3}} &= -2\Omega\Upsilon \omega^{\hat{1}} \wedge \omega^{\hat{2}} \wedge \omega^{\hat{3}} + \left(\frac{1}{\rho} (C'\Upsilon + M'\Omega - \rho'') - \Omega^2 - \Upsilon^2 \right) \omega^{\hat{0}} \wedge \omega^{\hat{1}} \wedge \omega^{\hat{2}} + \Upsilon' \omega^{\hat{0}} \wedge \omega^{\hat{1}} \wedge \omega^{\hat{3}}. \end{aligned}$$

Considering the energy-momentum current as defined in (49), the first field equation (35) is solved by

$$\Upsilon(r) = \Omega(r) = 0 \quad (55)$$

and

$$\rho = \frac{1}{\sqrt{\lambda}} \sin(\sqrt{\lambda} r), \quad (56)$$

where a constant of integration has been determined by the requirement that the metric must be Minkowskian in the limit $r \rightarrow 0$. Using (55) and (56) with the boundary conditions $M(0) = C(0) = 0$, the expressions (53) can be integrated to give the explicit forms of the functions $C(r)$

and $M(r)$, respectively: $M(r) = \sigma \int_0^r \rho dr'$ and $C(r) = \beta \int_0^r \rho dr'$. Using (56), these functions are given implicitly by

$$\lambda \int_0^r \rho(r') dr' = 1 - \cos(\sqrt{\lambda}r). \quad (57)$$

The expressions for $M(r)$ and $C(r)$ should be compared with the string's mass. Its mass per unit length is found by integrating the density over a cross section of the cylinder,

$$\mu \equiv \lambda \int_0^{2\pi} \int_0^R \omega^{\hat{1}} \wedge \omega^{\hat{2}} = \lambda \int_0^{2\pi} \int_0^R \rho(r) dr \wedge d\phi, \quad (58)$$

where R is the radial coordinate distance from the origin to the surface of the cylinder. Likewise, the two components of the spin are given by similar integrals with spin densities replacing the energy density:

$$j^{\hat{0}} \equiv \sigma \int_0^{2\pi} \int_0^R \rho(r) dr \wedge d\phi, \quad (59a)$$

$$j^{\hat{3}} \equiv \beta \int_0^{2\pi} \int_0^R \rho(r) dr \wedge d\phi. \quad (59b)$$

Note that these two equations can be expressed more compactly by means of the surface values of the metric coefficients $M(r)$ and $C(r)$. Hence, the results are

$$\mu = 2\pi \left[1 - \cos(\sqrt{\lambda}R) \right], \quad (60a)$$

$$j^{\hat{0}} = 2\pi M(R), \quad (60b)$$

$$j^{\hat{3}} = 2\pi C(R), \quad (60c)$$

where j^μ are the components of a vector. These relations make up the boundary conditions for the exterior gravitational field that we will construct in the next section.

With the field equations solved, the curvature two-form is left with the only nonvanishing components

$$R^{\hat{1}}_{\hat{2}} = -R^{\hat{2}}_{\hat{1}} = \lambda \omega^{\hat{1}} \wedge \omega^{\hat{2}}, \quad (61)$$

which is the finite version of expression (23) for the wedge disclination (order six).

6.1.3 Exterior solution

We shall now use the AKP conditions as formulated in Sect. 5.2 and find the exterior solution corresponding to the above spin-polarized cylinder. By construction, the vacuum solution will comprise the two screw dislocations (orders zero and three) and the wedge disclination (order six). Hence, we use the line element

$$g = - \left(dt + \frac{\Theta^0}{2\pi} d\phi \right)^2 + dr^2 + \left(1 - \frac{\Phi^6}{2\pi} \right)^2 (r + r_0)^2 d\phi^2 + \left(dz + \frac{\Theta^3}{2\pi} d\phi \right)^2, \quad (62)$$

where the constant parameters Θ^0 , Θ^3 , and Φ^6 have the same interpretation as in Sect. 3 and belong to the three distortions under consideration. The spacetime with the (locally) flat metric (62) has

also been investigated recently by Tod [12] and by Gal'tsov and Letelier [10]. By straightforward computation we find that (43) and (44) are satisfied for the present matter currents (49) and (50). The junction conditions (45) and (46) read

$$\begin{aligned}
g_{\phi\phi}|_+ &= g_{\phi\phi}|_- , \\
g_{\phi z}|_+ &= g_{\phi z}|_- , \\
g_{\phi t}|_+ &= g_{\phi t}|_- , \\
g_{\phi\phi,r}|_+ &= g_{\phi\phi,r}|_- - 2K_{\phi\phi}{}^r , \\
g_{\phi z,r}|_+ &= g_{\phi z,r}|_- - 2K_{(\phi z)}{}^r , \\
g_{\phi t,r}|_+ &= g_{\phi t,r}|_- - 2K_{(\phi t)}{}^r .
\end{aligned}$$

Written out explicitly, we have the following system of algebraic equations for determining a , B , r_0 , and b :

$$\begin{aligned}
\left(1 - \frac{\Phi^6}{2\pi}\right)^2 (R + r_0)^2 + b^2 - a^2 &= \rho(R)^2 + C(R)^2 - M(R)^2 , \\
\frac{\Theta^0}{2\pi} &= M(R) , \\
\frac{\Theta^3}{2\pi} &= C(R) , \\
2\left(1 - \frac{\Phi^6}{2\pi}\right)^2 (R + r_0) &= 2\rho'(R)\rho(R) + 2C'(R)C(R) - 2M'(R)M(R) \\
&\quad + 2\rho(R)[\sigma M(R) - \beta C(R)] , \\
0 &= C'(R) - \beta\rho(R) , \\
0 &= -M'(R) + \sigma\rho(R) .
\end{aligned}$$

Combining the above conditions with (56) and (60) we get

$$\left(1 - \frac{\Phi^6}{2\pi}\right) = \cos(\sqrt{\lambda}R) = 1 - \mu/(2\pi) , \tag{63}$$

$$\frac{\Theta^0}{2\pi} = M(R) = \frac{j^{\hat{0}}}{2\pi} = -\frac{2\gamma(v)s}{\lambda} (\cos(\sqrt{\lambda}R) - 1) , \tag{64}$$

$$\frac{\Theta^3}{2\pi} = C(R) = \frac{j^{\hat{3}}}{2\pi} = -\frac{2\gamma(v)vs}{\lambda} (\cos(\sqrt{\lambda}R) - 1) , \tag{65}$$

$$r_0 = \frac{1}{\sqrt{\lambda}} \tan(\sqrt{\lambda}R) - R , \tag{66}$$

where we have evaluated the integrals (59a) and (59b) with (51) inserted. The solution falls into three classes depending on the nature of the vector j^μ . If it is timelike, the solution corresponds to the spinning string [28, 58]. If it is null, the metric can be regarded as the limiting case of a cosmic string interacting with a gravitational wave, and if it is spacelike, the solution is a so-called cosmic dislocation [10].

The mass and spin parameters of the source can be related to dislocations and disclinations as described in Section 2. Hence, the mass per length μ produces an axial disclination (distortion of

order six) with disclination strength $\Phi^6 = \mu$, see Table 3; the zeroth component of the spin vector $j^{\hat{0}}$ induces a time-dislocation (order zero) and $j^{\hat{3}}$ results in an axial dislocation (order three); the corresponding exterior metrics are those given in Table 2. The exterior metric (62) can thus be produced by a combination of these spacetime distortions.

The deficit angle $\Delta\phi$ outside the string is determined by $\Delta\phi = 2\pi(1 - B) = \mu$. Note that in the conical case there is a maximal radius of the cylinder given by

$$R = \frac{\pi}{2}\lambda^{-1/2} . \quad (67)$$

This maximal radius corresponds to a string with deficit angle and mass per length equal to 2π . In this case, r_0 diverges, and in the first term of $g_{\phi\phi}$ in the exterior metric, only the combination $B^2 r_0^2$ survives, making $g_{\phi\phi}$ constant here. Thus, for $\mu = 2\pi$, spacetime becomes cylindrical rather than conical.

7 Concluding remarks

A Poincaré gauge theory is a natural four-dimensional generalization of the $SO(3) \rtimes T(3)$ gauge theory of solid continua with line defects. From this perspective we have found spacetime equivalents of the Volterra distortions of elastic media. For a subset of these spacetime distortions we have found the corresponding nonsingular sources in the Einstein–Cartan theory of gravity.

If we recall the interpretation of the interior solution in terms of the convective spin fluid under consideration—see Sect. 5.1 and the remarks at the end of Sect. 6.1.2—we find that the geometry of the combined interior and exterior spacetime can be formulated with respect to two complementary sets of parameters. Starting with the interior spacetime, the relevant set is $(\lambda, s, v) = (\text{mass density, spin density, velocity})$; we call this the *physical* set. If, on the other hand, we start with the vacuum geometry, we should use the distortion strengths $(\Theta^0, \Theta^3, \Phi^6)$; this is the *geometrical* set of parameters. While expressions (63)–(65) represent the geometrical set in terms of the physical set, the complementary relations are

$$\lambda = \frac{1}{R^2} \text{acos}^2 \left(1 - \frac{\Phi^6}{2\pi} \right) , \quad (68)$$

$$s = \frac{\sqrt{(\Theta^0)^2 - (\Theta^3)^2}}{2R^2(\Phi^6 - 4\pi)} \text{acos} \left(1 - \frac{\Phi^6}{2\pi} \right) , \quad (69)$$

$$v = -\frac{\Theta^3}{\Theta^0} . \quad (70)$$

Correspondingly, all relevant geometrical quantities can be formulated with respect to either (λ, s, v) or $(\Theta^0, \Theta^3, \Phi^6)$. In particular, the time dislocation and the axial dislocation are no longer independent of each other: by (70), the corresponding dislocation strengths are subject to the relation $\Theta^3 = -v\Theta^0$. For instance, if Θ^3 is fixed to some finite value, then $\Theta^0 \rightarrow 0$ would imply $v \rightarrow \infty$, which is clearly forbidden on physical grounds, since the fluid velocity must not exceed the speed of light. Thereby we conclude that the axial dislocation cannot occur alone, it is always accompanied by a time dislocation. Moreover, by the same token, the ‘cosmic dislocation’ [10], is unphysical in the sense that it corresponds to a spacelike four-velocity of the spin fluid.

Whether interior solutions can be found for the remaining (space- or space- and time-supported) distorted vacua remains an open question and deserves further investigation. The present strategy

for constructing string sources is, at least in principle, applicable to these geometries, too: (i) take the *coframe* and replace the constant distortion strength by a *function*, (ii) find the nonvanishing components of the *torsion* two-form and make a corresponding ansatz for the interior spacetime, and (iii) solve the field equations. *If* a solution is found, then, by construction, it is expected to reproduce the respective distorted vacuum. It turns out, however, that in the generic case we have to face two problems that didn't appear in the cases solved.

First of all, most of the remaining distorted vacua are either not cylindrically symmetric or nonstatic, compare Tables 2 and 3. Secondly, the structure of the *second* field equation, with the the present spin fluid model, only allows for a quite restricted torsion part—as demonstrated in the Appendix for one of the space- and time-supported defects—of the interior geometry. While the first mentioned problem merely is of technical nature, the circumvention of the second one requires substantial changes of the physical models used. One possible modification could be to consider a different spin-fluid matter model, such as that developed by Ray and Smalley [59], which was recently used by Krisch [60] to find a family of spinning string-type solutions in a spacetime with curvature and torsion.

Acknowledgements

We thank F.W. Hehl for critically reading the manuscript and F. Gronwald and Yu.N. Obukhov for interesting discussions. Most of the computations have been checked with the aid of REDUCE [61] making use of the Excalc package [62]. The results of Sect. 6.1 have been found using the tensor algebra package CARTAN [63]. HHS thanks F.W. Hehl and the *Graduiertenkolleg Scientific Computing*, University of Cologne, for hospitality during the initial stage of this work. One of the authors (RAP) is supported by the *Graduiertenkolleg Scientific Computing*, University of Cologne and GMD—German National Research Center for Information Technology, St. Augustin.

Appendix

In Sect. 6 we have demonstrated how to find, in the framework of EC theory, extended matter sources corresponding to the vacuum geometries of space-supported distorted spacetimes. Applying the same scheme to the space- and time-supported vacuum defects of Sect. 4, we proceed as follows. Define the orthonormal coframe

$$\begin{aligned}\omega^{\hat{0}} &= dt - \frac{E}{2\pi(t^2 + z^2)}(z dt - t dz) = dt - \frac{E}{2\pi} d\zeta \\ \omega^{\hat{1}} &= dr \\ \omega^{\hat{2}} &= r d\phi \\ \omega^{\hat{3}} &= dz ,\end{aligned}\tag{71}$$

which can be obtained from (25) by replacing the constant dislocation strength χ_0 by the function $E = E(t, z)$. In view of the (fixed) exterior geometry that was determined in Sect. 4, the torsion two-form is required to have the only nontrivial component

$$T^{\hat{0}} = 2\kappa\alpha \eta^{\hat{1}\hat{2}} = 2\kappa\alpha \omega^{\hat{0}} \wedge \omega^{\hat{3}} ,\tag{72}$$

with some function $\alpha = \alpha(t, z)$. The resulting curvature two-form has the nontrivial components

$$R^{\hat{0}}_{\hat{3}} = R^{\hat{3}}_{\hat{0}} = \frac{\Xi(tE_t + zE_z) + E(t\Xi_t + z\Xi_z) + \Xi_z(t^2 + z^2)}{zE + t^2 + z^2} \omega^{\hat{0}} \wedge \omega^{\hat{3}}, \quad (73)$$

where we have introduced the function

$$\Xi \equiv 2\kappa\alpha + \frac{tE_t + zE_z}{zE + t^2 + z^2}. \quad (74)$$

With ansatz (72), the second field equation, after some algebra, implies

$$\tau^{\hat{1}\hat{3}} = -\kappa\alpha\eta^{\hat{1}}, \quad \tau^{\hat{2}\hat{3}} = -\kappa\alpha\eta^{\hat{2}}, \quad (75)$$

while all other components of the canonical spin three-form vanish. The form (75) of the spin current, contrary to the situation we had in Sect. 6, is out of the scope of the present matter model, since (38) would imply $S^{\hat{1}\hat{3}} = S^{\hat{2}\hat{3}} = -\kappa\alpha$ for the spin density, which clearly is possible, and both $u = \eta^{\hat{1}}$ and $u = \eta^{\hat{2}}$ for the flow three-form u , which is impossible since generally $\eta^\alpha \neq \eta^\beta$ for $\alpha \neq \beta$. A similar argument holds for the space-supported dislocations of order one and two. Let us reiterate, though, that this inconvenience is due to the specific matter model used here, and it remains to be asked if a differently defined spin fluid behaves differently in this respect.

References

- [1] A. Vilenkin. Gravitational field of vacuum domain walls and strings. *Phys. Rev. D*, 23:852–857, 1981.
- [2] G.W. Gibbons, S.W. Hawking, and T. Vachaspati, editors. *The Formation and Evolution of Cosmic Strings*. Cambridge University Press, Cambridge, 1990.
- [3] A. Vilenkin and E.P.S. Shellard. *Cosmic Strings and Other Topological Defects*. Cambridge University Press, Cambridge, 1994.
- [4] W.A. Hiscock. Exact gravitational field of a string. *Phys. Rev. D*, 31:3288–3290, 1985.
- [5] J.A.G. Vickers. Generalized cosmic strings. *Class. Quantum Grav.*, 4:1–9, 1987.
- [6] F.W. Hehl, P. von der Heyde, G.D. Kerlick, and J. Nester. General relativity with spin and torsion: Foundations and prospects. *Rev. Mod. Phys.*, 48:393–416, 1976.
- [7] J.D. Bekenstein. Chiral cosmic strings. *Phys. Rev. D*, 45:2794–2801, 1992.
- [8] P.S. Letelier. Spinning cosmic strings as torsion line spacetime defects. *Class. Quantum Grav.*, 12:471–478, 1995.
- [9] A. Holz. Topological properties of linked disclinations and dislocations in solid continua. *J. Phys. A: Math. Gen.*, 25:L1–L10, 1992.
- [10] D.V. Gal'tsov and P.S. Letelier. Spinning strings and cosmic dislocations. *Phys. Rev. D*, 47:2473–2476, 1993.
- [11] D.G.B. Edelen. Space–time defect solutions of the Einstein field equations. *Int. J. Theor. Phys.*, 33:1315–1334, 1994.
- [12] K.P. Tod. Conical singularities and torsion. *Class. Quantum Grav.*, 11:1331–1339, 1994.
- [13] A. Holz. Geometry and action of arrays of disclinations in crystals and relation to (2+1)-dimensional gravitation. *Class. Quantum Grav.*, 5:1259–1282, 1988.

- [14] P. de Sousa Gerbert. On spin and (quantum) gravity in $(2 + 1)$ dimensions. *Nucl. Phys. B*, 346:440–472, 1990.
- [15] C. Kohler. Point particles in $2 + 1$ dimensional gravity as defects in solid continua. *Class. Quantum Grav.*, 12:L11–L15, 1995.
- [16] C. Kohler. Line defects in solid continua and point particles in $(2 + 1)$ -dimensional gravity. *Class. Quantum Grav.*, 12:2977–2993, 1995.
- [17] V. Volterra. Sur l'équilibre des corps élastiques multiplement connexes. *Ann. Éc. Norm. Sup.*, 24:401–517, 1907.
- [18] F.R.N. Nabarro. *Theory of Crystal Dislocations*. The International Series of Monographs on Physics. Oxford University Press, Oxford, 1967. Section 8.4.3 on timelike dislocations.
- [19] M. Kléman. The general theory of disclinations. In F.R.N. Nabarro, editor, *Dislocations in Solids*, volume 5, pages 243–297. North-Holland, Amsterdam, 1980.
- [20] E. Kröner. Continuum theory of defects. In R. Balian, M. Kléman, and J.-P. Poirier, editors, *Physics of Defects, Les Houches, Session 35*. North-Holland, Amsterdam, 1981.
- [21] L. Marder. Flat space-times with gravitational fields. *Proc. Roy. Soc. London, Ser. A*, 252:45–50, 1959.
- [22] L. Marder. Locally isometric spacetimes. In *Recent Developments in General Relativity – Volume Dedicated to Leopold Infeld in Connection with his 60th Birthday*, pages 333–338. Pergamon Press, Oxford, 1962.
- [23] R. Geroch and J. Traschen. Strings and other distributional sources in general relativity. *Phys. Rev. D*, 36:1017–1031, 1987.
- [24] C.J.S. Clarke, J.A. Vickers, and J.P. Wilson. Generalized functions and distributional curvature of cosmic strings. *Class. Quantum Grav.*, 13:2485–2498, 1996.
- [25] J.R. Gott, III. Gravitational lensing effects of vacuum strings: exact solutions. *Astrophys. J.*, 288:422–427, 1985.
- [26] B. Linet. The static metrics with cylindrical symmetry describing a model of cosmic strings. *Gen. Rel. Grav.*, 17:1109–1115, 1985.
- [27] H.H. Soleng. Spin-polarized cylinder in Einstein–Cartan theory. *Class. Quantum Grav.*, 7:999–1007, 1990.
- [28] H.H. Soleng. A spinning string. *Gen. Rel. Grav.*, 24:111–117, 1992.
- [29] A.D. Sakharov. Vacuum quantum fluctuations in curved space and the theory of gravitation. *Doklady Akad. Nauk S.S.S.R.*, 177:70–71, 1967. [*Sov. Physics Doklady*, 12:1040–1041, 1968].
- [30] E. Kröner. The differential geometry of elementary point and line defects in Bravais crystals. *Int. J. Theor. Phys.*, 29:1219–1237, 1990.
- [31] L. Mistura. Cartan connection and defects in Bravais lattices. *Int. J. Theor. Phys.*, 29:1207–1218, 1990.
- [32] A. Kadić and D.G.B. Edelen. *A Gauge Theory of Dislocations and Disclinations*, volume 174 of *Lecture Notes in Physics*. Springer, Berlin, 1983.
- [33] E. Kröner. On gauge theory in defect mechanics. In E. Kröner and K. Kirchgässner, editors, *Trends in Applications of Pure Mathematics to Mechanics*, volume 249 of *Lecture Notes in Physics*, pages 281–294. Springer, Berlin, 1986.
- [34] H. Kleinert. *Gauge Fields in Condensed Matter*, volume II. World Scientific, Singapore, 1989.

- [35] N. Rivier. Gauge theory and geometry of condensed matter. In J.F. Sadoc, editor, *Geometry in Condensed Matter Physics*, volume 9 of *Directions in Condensed Matter Physics*, pages 1–88. World Scientific, Singapore, 1990.
- [36] C. Malyshev. Underlying algebraic and gauge structures of the theory of disclinations. *Arch. Mech.*, 45:93–105, 1993.
- [37] A.A. Tseytlin. Poincaré and de Sitter gauge theories of gravity with propagating torsion. *Phys. Rev. D*, 26:3327–3341, 1982.
- [38] D. Ivanenko and G. Sardanashvily. The gauge treatment of gravity. *Phys. Rep.*, 94:1–45, 1983.
- [39] E.W. Mielke, J.D. McCrea, Y. Ne’eman, and F.W. Hehl. Avoiding degenerate coframes in an affine gauge approach to quantum gravity. *Phys. Rev. D*, 48:673–679, 1993.
- [40] F.W. Hehl, J.D. McCrea, E.W. Mielke, and Y. Ne’eman. Metric-affine gauge theory of gravity: Field equations, Noether identities, world spinors, and breaking of dilation invariance. *Phys. Rep.*, 258:1–171, 1995.
- [41] E.W. Mielke. *Geometrodynamics of Gauge Fields*, volume 3 of *Physical Research*. Akademie-Verlag, Berlin, 1987.
- [42] G. Grignani and G. Nardelli. Gravity and the Poincaré group. *Phys. Rev. D*, 45:2719–2731, 1992.
- [43] A. Trautman. The geometry of gauge fields. *Czech. J. Phys. B*, 29:107–116, 1979.
- [44] C.N. Yang. Integral formalism for gauge fields. *Phys. Rev. Lett.*, 33:445–447, 1974.
- [45] V.B. Bezerra and P.S. Letelier. Holonomy transformations and a class of spacetime topological defects. *Class. Quantum Gravity*, 8:L73–L76, 1991.
- [46] R.J. Petti. On the local geometry of rotating matter. *Gen. Rel. Grav.*, 18:441–461, 1986.
- [47] M. Göckeler and T. Schücker. *Differential Geometry, Gauge Theories, and Gravity*. Cambridge Monographs in Mathematical Physics. Cambridge University Press, Cambridge, 1987.
- [48] A. Trautman. On the structure of the Einstein–Cartan equations. In *Differential Geometry, Symposia Mathematica*, volume 12, pages 139–162. Academic Press, London, 1973.
- [49] P. Baekler, E.W. Mielke, and F.W. Hehl. Dynamical symmetries in topological 3D gravity with torsion. *Nuovo Cimento B*, 107:91–110, 1992.
- [50] F.W. Hehl, P. Von der Heyde, and G.D. Kerlick. General relativity with spin and torsion and its deviations from Einstein’s theory. *Phys. Rev. D*, 10:1066–1069, 1974.
- [51] G.D. Kerlick. Cosmology and particle production via gravitaitonal spin–spin interaction in the Einstein–Cartan–Sciama–Kibble theory of gravity. *Phys. Rev. D*, 12:3004–3006, 1975.
- [52] L.S. Smalley and J.P. Krisch. Energy conditions in non-Riemannian spacetimes. *Phys. Lett. A*, 196:147–153, 1994.
- [53] Yu.N. Obukhov and R. Tresguerres. Hyperfluid — a model of classical matter with hypermomentum. *Phys. Lett. A*, 184:17–22, 1993.
- [54] Yu.N. Obukhov. On a model of an unconstrained hyperfluid. *Phys. Lett. A*, 210:163–167, 1996.
- [55] W. Arkuszewski, W. Kopczyński, and V.N. Ponomariev. Matching conditions in the Einstein–Cartan theory of gravitation. *Commun. Math. Phys.*, 45:183–190, 1975.
- [56] P. Chmielowski. Matching and junction conditions in the Poincaré gauge theory of gravity with quadratic Lagrangian. *Prog. Theor. Phys.*, 88:691–702, 1992.
- [57] H.H. Soleng. Negative energy densities in extended sources generating closed timelike curves in general relativity with and without torsion. *Phys. Rev. D*, 49:1124–1125, 1994.

- [58] P.O. Mazur. Induced angular momentum on superconducting cosmic strings. *Phys. Rev. D*, 34:1925–1927, 1986.
- [59] J.R. Ray and L.R. Smalley. Improved perfect-fluid energy–momentum tensor with spin in Einstein–Cartan spacetime. *Phys. Rev. Lett.*, 49:1059–1061, 1982. Erratum: *Phys. Rev. Lett.*, 50:623, 1983.
- [60] J.P. Krisch. A family of strings with spin. *Gen. Rel. Grav.*, 28:69–76, 1996.
- [61] A.C. Hearn. *REDUCE User’s Manual, Version 3.5*. RAND Publication CP78 (Rev. 10/93), The RAND Corporation, Santa Monica, CA 90407–2138, 1993.
- [62] E. Schrüfer. *EXCALC: A System for Doing Calculations in the Calculus of Modern Differential Geometry*. GMD, Institut I1, D–53757 St.Augustin, Germany, 1994.
- [63] H.H. Soleng. *Tensors in Physics: User’s Guide and Disk for the Mathematica Package CARTAN, Version 1.2*. Scandinavian University Press, Oslo, 1996.