

W/V-Band RF Propagation Experiment Design

R. Acosta, J. Nessel, R. Simons, M. Zemba, J. Morse and J. Budinger

*NASA Glenn Research Center
21000 Brookpark Road, MS 54-1
Cleveland OH 44135-3127*

Abstract

The utilization of frequency spectrum for space-to-ground communications applications has generally progressed from the lowest available bands capable of supporting transmission through the atmosphere to the higher bands, which have required research and technological advancement to implement. As communications needs increase and the available spectrum in the microwave frequency bands (3–30 GHz) becomes congested globally, future systems will move into the millimeter wave (mm-wave) range (30–300 GHz). While current systems are operating in the K_a-band (20–30 GHz), systems planned for the coming decades will initiate operations in the Q-Band (33–50 GHz), V-Band (50–75 GHz) and W Band (75–110 GHz) of the spectrum. These bands offer extremely broadband capabilities (contiguous allocations of 500 MHz to 1GHz or more) and an uncluttered spectrum for a wide range of applications. NASA, DoD and commercial missions that can benefit from moving into the mm-wave bands include data relay and near-Earth data communications, unmanned aircraft communications, NASA science missions, and commercial broadcast/internet services, all able to be implemented via very small terminals. NASA Glenn Research Center has a long history of performing the inherently governmental function of opening new frequency spectrum by characterizing atmospheric effects on electromagnetic propagation and collaborating with the satellite communication industry to develop specific communications technologies for use by NASA and the nation. Along these lines, there are critical issues related to W/V-band propagation that need to be thoroughly understood before design of any operational system can commence. These issues arise primarily due to the limitations imposed on W/V-band signal propagation by the Earth's atmosphere, and to the fundamental lack of understanding of these effects with regards to proper system design and fade mitigation.

In this paper, The GRC RF propagation team recommends measurements that are required to assure that the risk associated with the use of mm-wave is minimized. We develop first order beacon and transponder system payload requirements and beacon terminal requirements. We will suggest and discuss a possible hardware implementation for the space segment, as well for the ground segment. A discussion on a propagation measurement campaign for taking relevant statistical data is also included.

1. Introduction

Based on GRC's experience in global K_a-band propagation measurements and analysis for over two decades, there are several critical issues related to W/V-band propagation that need to be thoroughly understood before any system planning and system design is initiated [1]. These issues are primarily due to the effects of the Earth's atmosphere and their impact on system availability and margin. The first order atmospheric effects at these short wavelengths are:

- **Gaseous Absorption** – During clear sky conditions, the sole attenuation mechanism at W/V bands is due to atmospheric gaseous components (predominantly oxygen and water vapor) and could represent a non-trivial (e.g. 1 – 2.5 dB) contribution to total path attenuation in the W/V-band [2].
- **Cloud Attenuation** – Cloud attenuation at W/V-bands can contribute significant loss (>10 dB) for total path attenuation, which is much more significant than observed at typical K_a-band frequencies.
- **Rain Attenuation** – Attenuation due to rain is the dominant loss mechanism when dealing with communications signals above the K_a-band. Though rain is a ~1% phenomenon (site dependent), its presence will fundamentally limit the availability of W/V-band signals and could result in unrealistic link margin requirements [3].

- **Scintillation** – Rapid fluctuations in the refractive index of the atmosphere induce rapid variations in the attenuation of the propagating signal. Scintillation effects occur on time scales under ~0.5 sec and will limit the performance of high data rate, complex modulation systems.
- **Depolarization** – For maximum spectral efficiency (frequency reuse systems), it is important to characterize signal leakage between polarizations of the same signal via simultaneous co-polarization and cross-polarization measurements. This propagation effect is known to be dominant during and surrounding local rain events.
- **Group Delay** – The advantage of exploiting W/V-bands is the tremendous amount of bandwidth available to operate high data rate systems. However, group delay, or dispersion, across the bandwidth will naturally limit the full use of the spectrum unless it is thoroughly characterized via transponder-based atmospheric-induced dispersion characterization [4].
- **Atmospheric Noise** – The atmosphere has an equivalent black body temperature. At V-band frequencies, this temperature varies from about 10K to 40K closer to the ambient temperature.
- **Wet or Snow-Covered Antenna** – Condensation and snow on the antenna cause signal losses. These losses can be as large as several dB.

Reliable statistics are needed to predict the above effects for slant-path applications. Note that each effect is not only a function of frequency, but also of location, path elevation angle, and season (time). Since it is not possible to make observations at every location, the region of interest can be divided into several rain or atmospheric climate zones. A climate zone is an area on the ground that has certain statistical attribute. For example, the characteristic that rain rates exceeding a given threshold occur at a certain probability would constitute a rain climate zone.

2. Satellite Beacon and Transponder Architectures

A possible antenna (beacon and transponder) footprint architecture and ground station locations for a W/V-band satellite communication experiment is shown in **Fig. 1**. The depicted architecture provides continental U.S. (CONUS) coverage for beacon experiment and a spot beam for the transponder experiment. The characterization of fundamental atmospheric propagation effects (i.e. gaseous absorption, rain/cloud attenuation, scintillation, and depolarization) is to be performed via five propagation terminals located in five different rain rate regions and a wideband terminal located at the Glenn Research Center. The wideband propagation effects (e.g. group delay) are investigated using a transponder on the spacecraft (i.e. Uplink 81-86GHz, and Downlink 71 to 76 GHz). The beacon frequency can be located at the end (76 GHz) of the downlink spectrum for maximum transponder experimental utilization. If the spacecraft power and cost permits a second beacon at 27.5 GHz should be added coherently to the 76 GHz beacon to characterize and correlate the space-to-ground propagation fade effects. The beacon received only ground terminals designed to measure these propagation effects should consist of a digital beacon receiver, a total power radiometer, and a weather station.

The combination of beacon plus transponder configuration enables the addition of critical dispersion (group delay) measurements to fully characterize and understand all relevant atmospheric propagation-induced impairments to signal performance for realistic wide bandwidth communication systems. The W/V-band transponder also enables high data rate demonstrations (multi-Gbps). The coherent beacons permit high availability attenuation characterization by allowing the beacon receiver to track the frequency-locked 27.5 GHz signal during deep fades. Since the 27.5 GHz signal experiences less attenuation during rain fades, the 76 GHz signal can be measured when signal-to-noise ratios prevent 76 GHz signal lock. A coherent 27.5 GHz measurement along with a simultaneous 76 GHz measurement will also provide a reference for model development and an understanding of frequency model scaling factors for future system design where W/V-band data is unavailable.

A minimum beacon EIRP of 30 dBW at edge of coverage (EoC) and minimum transponder EIRP 55 dBW to maintain high availability links are required for fade and group delay measurements. Group delay measurement and characterization protocols were developed at GRC and validated through the ACTS K_a -band propagation measurement campaign, and these protocols are directly applicable to W/V-band. Field-proven, ACTS-like propagation ground terminals that are cost-effective, transportable, and have autonomous operations capability, can be operated at W/V-band with minor modifications (i.e. Reflector and Front End LNA) to the existing K_a -band terminal design. The relevant post-processing software for propagation analysis has been validated for K_a -

Band and can be applied to W/V-Band. A minimum data collection period of 36 months is suggested, with up to 60 months necessary for statistically valid analysis.

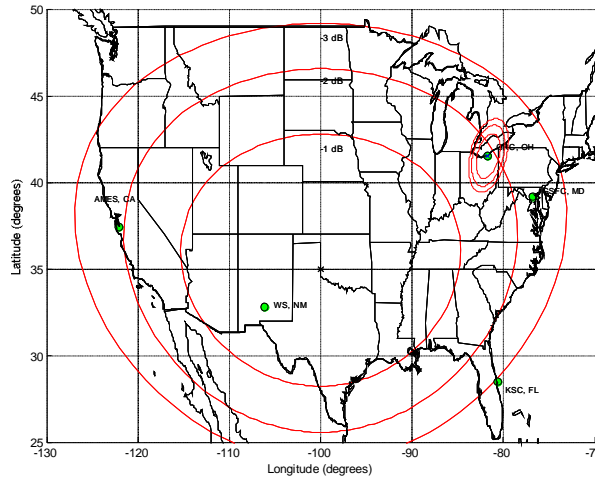

Fig. 1. The antenna footprint architecture and ground station locations for a W/V-Band satellite communication experiment with CONUS coverage for the beacon and a spot beam for the transponder.

2.1 Beacon Transmitter Implementation Overview

A block diagram of a satellite beacon transmitter for a continuous wave (CW) unmodulated RF carrier is presented in **Fig. 2**. Two distinct CW beacon signals will be transmitted from a satellite to Earth. The frequencies of these beacon signals are representative of the frequency bands that are designated for future space-to-Earth communication links. The chosen beacon frequencies are 27.5 GHz and 76 GHz. The generation of the unmodulated RF carrier at 27.5 GHz and 76 GHz takes place in two separate phase locked loop (PLL) stabilized dielectric resonator oscillators (DROs), which derive their input reference from a common highly stable temperature compensated crystal oscillator (TCXO). The TCXO is common to both PLL-DRO chains to ensure phase coherence. The respective outputs from the PLL-DRO is multiplied to the desired frequency and then amplified. A chain of narrow band monolithic microwave integrated circuit (MMIC) based amplifiers consisting of a pre amp, driver amp and a balanced power amp (PA) boost the output of the multiplier to the desired power level. The output of the PA is coupled via a coax-to-waveguide transition and a circulator to the antenna. Typically, the radiated power is in the range of 1 to 2 watts for the propagation experiments. Our survey indicates that most of the components and the MMIC amplifiers required to assemble a beacon transmitter at the above two frequencies are commercially available but require space qualification.

2.2 Satellite Transponder Implementation Overview

The CW beacon transmitters described above have narrow bandwidth and hence are unable to process high data rate waveforms. To investigate the effect of atmosphere on high data rate RF links and to develop a compensation or mitigation strategy based on adaptive equalization, adaptive coding and modulation techniques, a satellite transponder is required. These transponders are built around traveling-wave tube amplifiers (TWTAs) and include a high data rate modulator to generate the desired waveform and also have the capability to include forward error correction (FEC) codes.

A K_a -band space TWT is illustrated in **Fig. 3A**. The TWT has an output power of 200-watts and its efficiency is 60%. Although these space TWTs are routinely designed for NASA applications with 500 MHz of bandwidth, our experiments have shown that they have a usable bandwidth in excess of 3 GHz centered at 33 GHz [5]. In addition, we have demonstrated in a laboratory setting data throughput in excess of 20 Gbps with low bit error rate (BER) using a 128-QAM waveform through these TWTs [6]. Our plan is to develop a V-band space TWT for a satellite transponder and fly the transponder as a hosted payload for RF propagation experiments. A notional W/V-band transponder for data experiments is illustrated in **Fig. 3B**.

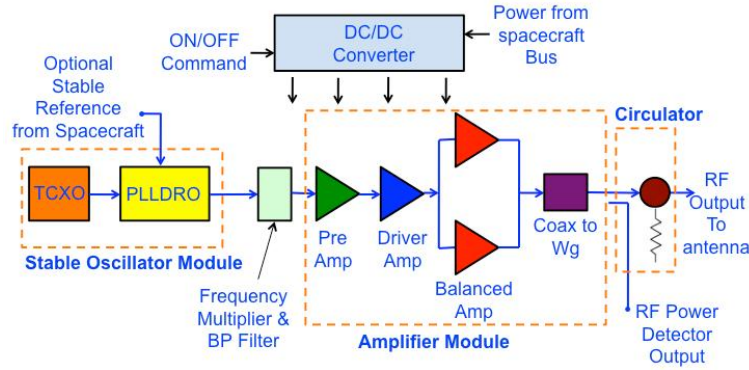

Fig. 2. Block diagram of a satellite beacon transmitter for a continuous wave (CW) unmodulated RF carrier.

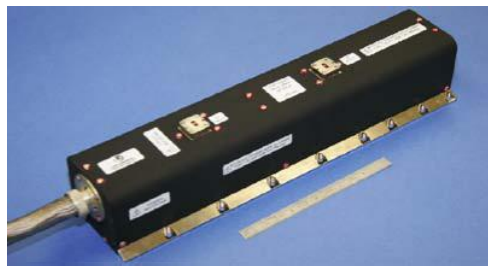

Fig. 3A. The L-3 ETI Model 999HA Ka-Band space TWT in a conduction cooled package.

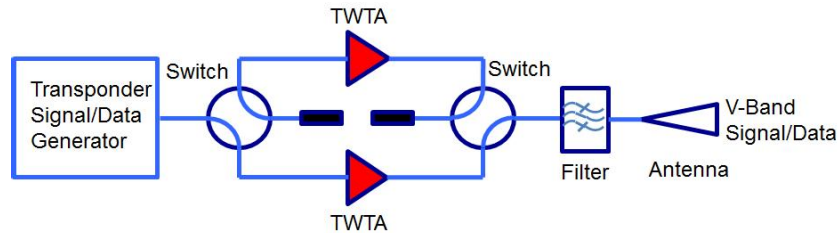

Fig. 3B. Notional W/V-band satellite transponder.

3.1 Spacecraft Beacon Transmitter Requirements

In this section, we discuss the system requirements of the spacecraft beacon. **Table 1** provides the proposed spacecraft beacon design goals that would need to be met by the eventual beacon system manufacturer for an optimal propagation campaign in the W/V-bands. The rationale behind the design specifications of the critical design elements can be found in the subsections listed in the last column of the **table 1**.

3.1.1 Operating Frequency: The specific operational frequencies of the K_a /V-band beacons are not a critical design element. However, the following frequencies are recommended based on the previous experience and knowledge of spectrum availability. For example, the 27.5 GHz tone is allocated for commercial uplink fade beacon and the 76 GHz tone resides at the edge of the W-band spectrum thus maximizing the available spectrum for communications. The eventual frequencies will obviously be optimized to realize a simple, robust coherent system.

3.1.2 Master Local Oscillator (LO): The LO frequency utilized to phase/frequency lock the K_a and V-band frequencies will be determined by the availability of the master LO on the spacecraft. However, a 10 MHz frequency phase locked to the K_a and V-band LOs to enable coherent signal generation is readily available via a rubidium source capable of meeting the phase noise requirements of the beacon system.

<i>Table 1. System design requirements for spacecraft beacons at K_a-Band and V-Band.</i>			
Parameter	Ka-Band Beacon	V-Band Beacon	Rationale
Operating Frequency	27.5 GHz	76 GHz	3.1.1
Master LO	10 MHz	10 MHz	3.1.2
Polarization	Linear	Linear	3.1.3
Cross-Polarization Discrimination (XPD)	Min. 25 dB	Min. 25 dB	3.1.4
EIRP (CONUS)	>30 dBW EoC	>30 dBW EoC	3.1.5
Power Stability	< 0.3 dB / day (rms)	< 0.3 dB / day (rms)	3.1.6
Phase Noise			3.1.6
@ 10 Hz	-30 dBc/Hz	-30 dBc/Hz	
@ 100 Hz	-60 dBc/Hz	-60 dBc/Hz	
@ 1 K Hz	-80 dBc/Hz	-80 dBc/Hz	
@ 10KHz	-100 dBc/Hz	-100 dBc/Hz	
@ > 10KHz	< -100 dBc/Hz	< -100 dBc/Hz	
Frequency Error	< ± 4×10 ⁻⁶ ppm BOL < ± 8×10 ⁻⁶ ppm EOL	< ± 4×10 ⁻⁶ ppm BOL < ± 8×10 ⁻⁶ ppm EOL	ACTS Experience
Frequency Stability	< ± .1×10 ⁻⁶ ppm/ day < ± 5×10 ⁻⁶ ppm / year	< ± .1×10 ⁻⁶ ppm/ day < ± 5×10 ⁻⁶ ppm/ year	ACTS Experience
Spurious (2 MHz from carrier) (1 MHz BW)	No spur greater than -20 dBm	No spur greater than -20 dBm	ACTS Experience
Acceptance Temperature	-10 to 55 °C	-10 to 55 °C	ACTS Experience

3.1.3 Polarization: A single linearly polarized beacon signal is all that is required to conduct depolarization measurements with a ground-based terminal utilizing a dual linear receive feed to measure co- and cross-polarization power levels.

3.1.4 Cross-Polarization Discrimination (XPD): A cross-polarization discrimination level of a minimum of 25 dB is necessary for high fidelity depolarization measurements. Based on the experience obtained from the ACTS propagation experiments, it has been determined that rain at K_a-band introduces depolarization losses comparable to this level, and in order to accurately measure this phenomenon, the beacon broadcast antenna must maintain XPD levels greater than 25 dB.

3.1.5 Effective Isotropic Radiated Power (EIRP): An EIRP of 30 dBW (EoC) is desired to provide the necessary power levels to close the link based on the current propagation terminal designs to measure rain-induced attenuation to a minimum 99% probability exceedance level (see the link budget in the next section for validation of this assumption).

3.1.6 Power Stability/Phase Noise: To obtain accurate power measurements over the lifetime of the spacecraft, beacon transmit power stability and phase noise must meet the threshold requirements detailed in Table 1.

3.2 Ground Terminal Requirements

The design goals for the ground terminals are to characterize the atmospheric propagation losses (due to gaseous absorption, rain and cloud attenuation, scintillation, and depolarization) for W/ V-band communication signals. It is suggested that the current GRC terminal used in the NASA SCan campaign be modified to fit the new system requirements of W/V-band campaign. This approach in the development of the terminals maximizes the dynamic range of the W/V-band beacon receiver for high availability characterization, maximizes system reliability (mean time before failure) and autonomy (minimal operator involvement), and minimizes design complexity, costs, and risk. Based on the goal and approach described above, the beacon receiver design requirements are described in Table 2. The rationale for the design choices are provided in the appropriate subsection listed in the last column of the table.

3.2.1 Antenna Diameter: A receive antenna beamwidth of approximately 0.8° (min) has been proven to provide the most robust propagation terminal design and is proposed for the K_a- and V-band antenna diameter in this propagation terminal design (1.2 m and 0.3 m, respectively). A 0.8° beamwidth (min) reduces the effects of satellite motion in the power measurement and eliminates the need for receiver terminal tracking, maximizing lifetime and reducing cost and operational load.

<i>Table 2 – System design requirements for the beacon receivers at Ka-band and V-band</i>			
Parameter	Ka-Band Receiver	V-Band Receiver	Rational
Recommended Frequency	27.5 GHz	76 GHz	--
Antenna Diameter	1.2 m	0.3 m	3.2.1
Polarization	Dual linear	Dual Linear	3.2.2
Cross-Polarization Isolation	<-30 dB	<-30 dB	3.2.2
Receiver-Noise Temperature	< 600K	< 1200 K	3.2.3
Frequency Tracking	<1 Hz Error	<1 Hz Error	3.2.4
Acquisition Bandwidth	10KHz	10KHz	3.2.4
Sampling Rate	Switchable: 1 or 10 Hz	Switchable: 1 or 10 Hz	3.2.5
Measurement Dynamic Range (Min)	50 dB	50 dB	3.2.6
Power Measurement Accuracy	< 0.1 dB (1 minute rms)	< 0.1 dB (1 minute rms)	3.2.7
Receiver Gain Stability	<0.2dB (10 minutes rms)	<0.2dB (10 minutes rms)	3.2.7
Carrier Acquisition Time after Signal Loss	< 5 sec	< 5 sec	ACTS Experience
Satellite Tracking	Fixed Pointing	Fixed Pointing	3.2.2
Portability	Transportable	Transportable	3.2.8
Radome	Site Dependent	Site Dependent	ACTS Experience
Wind Loading	< 150 mph	< 150 mph	ACTS Experience
Non-penetrating Mount	Yes	Yes	ACTS Experience
Thermal Stability RF and IF Enclosures	0.1 K (rms)	0.1 K (rms)	ACTS Experience

3.2.2 Polarization/Cross-Polarization Isolation: Dual linear polarization measurements provide quantification of the degree of depolarization losses induced by the atmosphere. This is critical to characterize dual polarization frequency reuse system performance and requires a minimum cross-polarization isolation of 30 dB to ensure accuracy in measurement.

3.2.3 Receiver Noise Temperature: Minimizing receiver noise temperature will allow for higher dynamic range attenuation measurements. In the proposed design, this is accomplished by maintaining separate receiver systems for the Ka-band and V-band propagation terminals and V-band radiometer (to minimize front end losses before the LNA). Based on commercial off the shelf (COTS) components for Ka- and V-band systems, a design goal of 400 K and 1200 K, respectively, is readily realizable.

3.2.4 Frequency Tracking/Acquisition Bandwidth: Frequency tracking within 1 Hz and acquisition bandwidth of 10 kHz is recommended based on previous ACTS receiver design.

3.2.5 Sampling Rate: To characterize scintillation effects, attenuation measurements must be performed at a minimum of 10 Hz. However, scintillation effects typically only dominate around and during rain events. Therefore, providing a user-switchable sampling capability allows the terminals to perform optimally during normal and scintillation-heavy conditions.

3.2.6 Measurement Dynamic Range: Maximizing dynamic range of the beacon receiver system is critical to characterize V-band attenuations during deep rain fades and obtain high availability (>99% exceedance) measurements. This is performed in the proposed design in two ways: (1) separating the Ka-band and V-band receivers, and (2) utilizing the coherent Ka-band signal to provide precision tracking of the V-band signal during rain fades.

3.2.7 Power Measurement Accuracy/Receiver Gain Stability/Thermal Stability: Stability requirements of the amplifiers are directly correlated with thermal stability of the RF and IF enclosures, which directly impact power measurement accuracy. The stated requirements are readily achievable by the GRC propagation terminals and provide accurate beacon power measurements.

3.2.8 Portability: System portability is desired so that additional experiments can be conducted beyond the primary 5-year characterization period. Upon conclusion of 5 years of data collection during the ACTS campaign, additional measurements for characterizing site diversity were performed by re-locating several of the terminals to other sites.

3.3 Digital Beacon Receiver Overview

The current GRC digital receiver (DRX) utilizes the Fast Fourier Transform (FFT) and has been operational in K_a -band systems for the past 5 years in Goldstone, California, White Sands, New Mexico, and Guam for amplitude and phase characterization of K_a -band signals (20.2/20.7 GHz). The receiver architecture needs to be modified to coherently operate at K_a/V -band system, as shown in the block diagram of **Fig. 4**.

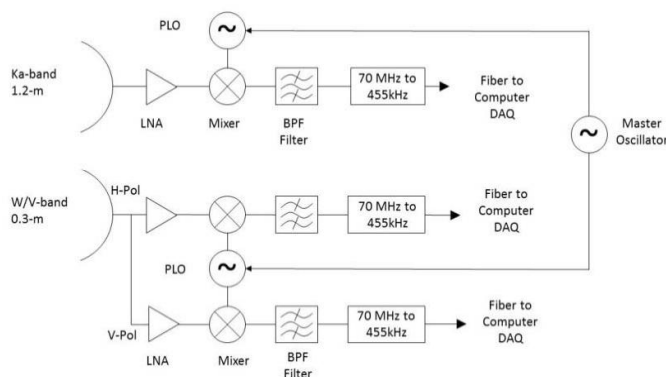

Fig. 4. Coherent K_a/V -band beacon receiver block diagram.

The advantages of the proposed receiver design include, first, proven reliability for site-dependent propagation characterization for the past 5 years. Second, coherent K_a -band signal provides frequency tracking of V-band signal during deep fades thus optimizing the dynamic range performance of the V-band beacon receiver. Third, simultaneous K_a -band measurement provides direct correlation of the uncharacterized V-band propagation losses with well-understood K_a -band propagation losses. Fourth, a separate V-band receiver system phase-locked to a master oscillator reference provides optimal solution for minimizing receiver temperature and thus maximizing the dynamic range. Fifth, a small V-band antenna (0.3 m) is capable of maintaining C/N_0 of >50 dB-Hz with $>99\%$ availability and thus maximizes system reliability (no open-loop tracking necessary, minimal operator involvement). As an alternate a 1.2 m V-band antenna can improve the dynamic range of the beacon receiver by ~ 15 dB, but will require tracking capability. Such a design will increase complexity, cost, reduce reliability, and require regular operator involvement. In addition it could result in unnecessary beacon receiver system downtime based on our experience. The conceptual mechanical layout of the beacon receiver portion of the propagation terminal is shown in **Fig. 5**. Co-located K_a - and V-band antennas of size 1.2 m and 0.3 m Cassegrain reflectors, respectively, are mounted to a fixed positioner with azimuth and elevation look angle control. The software developed by GRC for monitoring and data collection of the beacon receiver has been in operation for the past 5 years and has undergone minor enhancements. Extension of the software for use in the beacon receivers described herein will require minimal modification to the frequency estimation routine for V-band measurements.

4.0 Autonomous Operations Requirements

Each terminal must be capable of collecting data autonomously. Measurements of the signal amplitude, XPD, phase, weather parameters and sky temperature should be obtained at least once each second. A fast data rate collection sampled at 0.1 seconds for 10 second out each minute is also recommended. This would provide much needed scintillation data. The file should be updated frequently to minimize data loss data due to system failures and power outages. Ideally, the data file would be updated as the data is collected (each second), however, this may be too process intensive, and the interval may need to be reduced to each minute with real-time measurements being stored in memory between updates. To ensure data collection continues during power outages, a UPS should be used to allow data collection through at least 15 minutes of lost power. Two hours of backup power would likely ensure data collection through most outages in US. Power reliability may vary from site to site, thus the capabilities of the UPS should be considered independently for each site. In addition to beacon measurements, an accurate time stamp must be obtained from an external source so that the data can be coordinated with the external weather data and data collected at different terminals. The ACTS propagation

experiment has shown that the GPS receiver is most reliable method for obtaining this time stamp. Additionally, it is recommended that one computer be used to collect and time tag all the data (beacon,

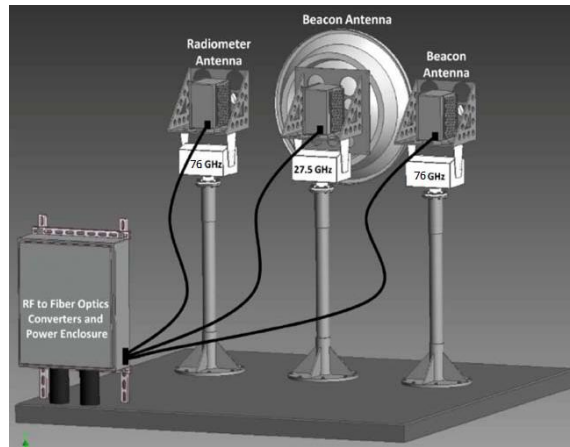

Fig. 5. Conceptual design of the Ka/V-band beacon receiver terminal.

radiometer, and weather) to avoid errors in time correlation of the data. Radiometer measurements should be made at two frequencies 27.5 GHz and 76 GHz, either with same terminal or through a separate radiometer terminal for the purpose of determining the signal reference level. It is best if the radiometer measurements are made with same system so that the reference level includes the noise level seen by the beacon chains in the antenna. Ancillary meteorological measurements, including weather radar, radiosonde and optical cloud monitoring should be employed where available.

5. Conclusion

This paper describes experimental campaign architecture for collecting V-Band propagation data using a geosynchronous satellite. The objective is to characterize satellite communication channels, and the campaign consists of 5 fixed sites. Only the measurements using the fixed sites were addressed in this paper. The terminals are assumed to have the RF/IF characteristics and share the same software for data processing. The data collected by these sites are archived at central location (e.g. GRC) for distribution to the user community.

References

- [1] F. Davarian, D. Rogers and R. Crane, "Special Issue on: Ka-Band Propagation Effects on Earth-Satellite Links," Proceeding of the IEEE, Vol. 85, No. 6, pp. 805-1024, June, 1997
- [2] ITU Recommendation ITU-R P.676, International Telecommunication Union – Radio Sector, Geneva, 1997.
- [3] R.K. Crane, "Propagation phenomena affecting satellite communication systems operating in the centimeter and millimeter wavelength bands," Proceedings of the IEEE, vol.59, no.2, pp. 173-188, Feb. 1971
- [4] R. Acosta, S. Johnson, and L. Blackman, "Ka-Band Wideband Dispersion Technology Verification Experiment," 6th Ka-Band Utilization Conference, Cleveland, Ohio, May 31, 2000.
- [5] R.N. Simons, J.D. Wilson, and D.A. Force, "High Power and Efficiency Space Traveling-Wave Tube Amplifiers with Reduced Size and Mass for NASA Missions," 2008 IEEE MTT-S Inter. Microwave Symposium Digest, pp. 319-322, Atlanta, GA, June 15-20, 2008.
- [6] D.G. Landon, R.N. Simons, E.G. Wintucky, J.Y. Sun, J.S. Winn, S. A. Laraway, W.K. McIntire, J.L. Metz, F.J. Smith, "Peak Satellite-to-Earth Data rates Derived from Measurements of a 20 Gbps Bread-board Modem," 2011 Inter. Military Communications Conf. (MILCOM 2011), Baltimore, MD, Nov 7-10, 2011.