

Final Report

Warfighter Physiological and Environmental Monitoring: A Study for the U.S. Army Research Institute in Environmental Medicine and the Soldier Systems Center

G.A. Shaw
A.M. Siegel
G. Zogbi
T.P. Opar

1 November 2004

Lincoln Laboratory
MASSACHUSETTS INSTITUTE OF TECHNOLOGY
LEXINGTON, MASSACHUSETTS

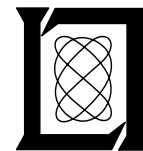

Prepared for the U.S. Army under Air Force
Contract F19628-00-C-0002.

Approved for public release; distribution is unlimited.

This report is based on studies performed at Lincoln Laboratory, a center for research operated by Massachusetts Institute of Technology. This work was sponsored by the U.S. Army under Air Force Contract F19628-00-C-0002.

This report may be reproduced to satisfy needs of U.S. Government agencies.

The ESC Public Affairs Office has reviewed this report, and it is releasable to the National Technical Information Service, where it will be available to the general public, including foreign nationals.

This technical report has been reviewed and is approved for publication.

FOR THE COMMANDER

Gary Tutungian
Administrative Contracting Officer
Plans and Programs Directorate
Contracted Support Management

Massachusetts Institute of Technology
Lincoln Laboratory

Warfighter Physiological and Environmental Monitoring:
A Study for the U.S. Army Research Institute in
Environmental Medicine and the Soldier Systems Center



G.A. Shaw
A.M. Siegel
G. Zogbi
Group 99
T.P. Opar
Group 97

Final Report

1 November 2004

Approved for public release; distribution is unlimited.

Lexington

Massachusetts

Executive Summary

An unprecedented opportunity exists to introduce real-time physiological and environmental monitoring technology into future US Army dismounted forces for use in both training and combat situations. The motivation is to enhance the survivability of the individual warfighter and to provide increased situational awareness to both combat medics and commanders during the course of a mission or field operation.

To seize this opportunity, the monitoring technology must be reliable, must be unobtrusive, and compelling in terms of value to both the lowest-echelon warfighters and their command chain. Realizing these objectives will require adapting and extending ambulatory medical monitoring technology well beyond the capabilities of current commercial devices and systems, and will place the US Army in a unique position, with the ability to continuously monitor a variety of physiological and metabolic parameters over extended periods of time and over a range of environments and activities.

The goal of integrating physiological sensors and supporting communication, processing, and power on the soldier in a manner that is affordable, reliable, light and simple is extremely challenging. One need only examine the state of the art in ambulatory medical monitoring to realize that existing approaches are deficient in a number of aspects:

1. **Cost** – Commercial real-time ambulatory medical monitoring systems (e.g., hospital or home wireless monitoring of respiration, ECG, SpO₂) cost in excess of \$25K per system
2. **Size, weight, and power** – Excluding the sensors, the mobile components (comm link and data archiving unit) of the smallest commercial system weigh 400 g, with a volume of 230 cm³, a wireless connection range of less than 50 m, continuous data archival capability of 24 hours, and non-real-time post-processing and analysis
3. **Intrusiveness** – Commercial systems require placement of adhesive electrodes
4. **Immunity to motion artifacts** – Motion introduces noise in the sensors and commercial systems have limited or no real-time processing to correct or suppress artifacts
5. **Scalability to multiple users** – Commercial systems are not designed to operate with multiple wearers in close proximity, so RF interference may occur and disrupt reporting of information when wearers come into close proximity
6. **Scalability in range of operation** – Commercial systems operate in unlicensed ISM bands or designated medical bands with maximum ranges of 50–150 m between wearer and wired base station
7. **Covertiness** – Commercial systems employ unlicensed RF transceivers to implement wireless links. These transceivers are easily detectable at standoff ranges and therefore represent a serious vulnerability in a combat situation, since the RF signal could be used to detect, locate, and track the movements of individual combatants

While the technology challenges associated with implementing a robust physiological and environmental monitoring system on the soldier are daunting, the biggest challenges will be gaining user acceptance of the system and meeting the near-term milestones for capability demonstration.

MIT Lincoln Laboratory undertook this study with support from MPMC/USARIEM and RDECOM/SSC to develop concepts for physiological and environmental monitoring, emphasizing the sensors, personal area network, and processing needed to implement a near-term system. An important constraint is that the near-term system be incrementally upgradeable as technology matures to produce a system compatible with the requirements for the Future Force Warrior (FFW) system to be fielded in the 2015 time frame. Warfighter Physiological Status Monitoring (WPSM) draft specifications for Land Warrior (LW) were used as a guide in developing the concepts presented in this report.

A significant development that occurred during the course of this study is the establishment of a requirement for insertion of physiological status monitoring in Land Warrior in the FY05 time period. This near-term requirement demands that commercial systems with FDA 510K approval be strongly considered. Therefore, two classes of system, one exploiting near-term technology and the other exploiting far-term technology are considered in this report. The near-term system is intended to meet the FY05 Land Warrior insertion goal and to provide the first opportunity in history to conduct long-term continuous physiological monitoring of a large number of soldiers in field environments. The far-term system concept is aimed at improving and extending performance of the system through a spiral development process. An evolutionary path from the near-term to the far-term system is proposed along with the technology enhancements needed to realize the far-term system.

Near-Term System

During the course of the study, two commercial systems for ambulatory monitoring of ECG and respiration, the Vivometric LifeShirt, and the Nexan NX-300, were identified as candidates for near-term field use. Since the Nexan system employs a wireless link to archive data and uses a lightweight sensor patch, it was recommended over the LifeShirt for near-term data collection and field trials. A series of meetings with Nexan and USARIEM personnel was organized, leading to a field test of the Nexan system during a Pike's Peak training exercise. The Nexan system provides ECG and respiration over a 914MHz wireless link. A key element of the system is a pre-wired, geometrically configured sensor patch that can be applied by a nonspecialist to collect two-lead ECG and two sensor, impedance-based, respiration. The system is capable of operating for several days on alkaline batteries and can be adapted to other types of interfaces. For example, under contract to NASA, Stanford bio lab has developed a wired interface to an iPAQ hand-held computer.

USARIEM has prior experience with field monitoring of heart-rate, core temperature, skin temperature, hydration, and activity. The challenge in fielding a near-term capability is to integrate these disparate technologies with a wireless personal area network and real-time processor, and to produce real-time, reliable estimates of current physiological status as well as forecasting future status. Developing an integrated solution requires advances in wireless personal networking, advances in algorithms for fusion of information, and advanced packaging of the sensors, network, and processing.

At present, the sensing technologies and subsystems required to realize a robust, multifunction warfighter physiological monitoring system vary in technology readiness levels from a low of TRL 3 to a high of TRL 9 for some commercially available subsystems. The lack of historical data and field experience with an integrated WPSM system demands a spiral development plan in which frequent prototyping and field-testing are performed to gain a better understanding of the hardware, software, algorithm, and conops issues associated with a WPSM system.

While seamless integration with the Future Force Warrior (FFW) system is the ultimate goal, including hosting of the algorithms on the soldier computer, a near-term implementation of WPSM will require a dedicated computer. The near-term baseline system should also focus on a small number of sensing functions to serve as a technology pathfinder.

The technology chosen for implementation of a wireless personal area network (WPAN) will have a major impact on the ultimate success of the system. There are commercial forces driving the development of many of the component technologies required for WPSM. In particular, small sensors, low-power computers, and even ambulatory medical monitoring, are under development for commercial markets. However, the Army's need for 72+ hours of operation, robustness in environmental extremes, and monitoring of highly active individuals, the likelihood of large numbers of co-located users, and the requirement for an undetectable electronic signature at stand-off ranges will require a unique and robust solution for the WPAN. The WPAN is the backbone of a WPSM system, enabling the transfer of sensor data to the computer through layers of clothing and supporting arbitrary positioning of sensors on the wearer. We believe the best approach for meeting the diverse requirements levied on the near-term PAN is a hybrid combination of wired and wireless technologies, with near-field magnetic induction offering the best compromise regarding achievable bandwidth, power dissipation, and standoff detectability.

A near-term WPSM baseline system concept is portrayed in the figure below. The system

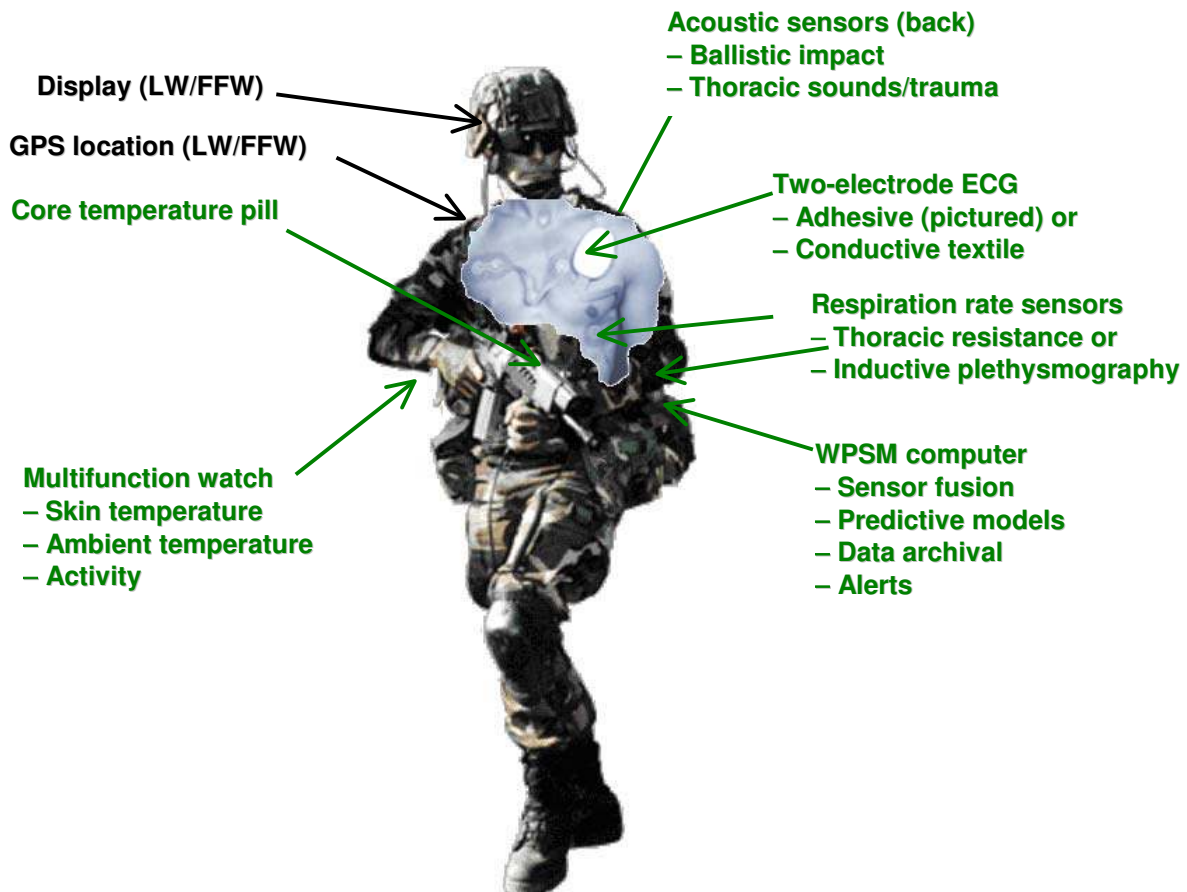

Figure ES.1 – WPSM baseline system concept

is assembled from a combination of existing 510k certified medical monitoring subsystems and R&D systems previously demonstrated by MRMC. Each of the technologies in the near-term system has been demonstrated in isolation, and some of the technologies have been demonstrated jointly. However, there is not presently an off-the-shelf solution for integrating the technologies together via a PAN, and no algorithm framework for fusion and inference from the heterogeneous collection of sensors. In addition to the integration challenges, substantial progress is needed in the packaging of the overall system to meet size, weight, power, and ease of use objectives.

Far-Term System

The far-term system is defined as one for which initial operating capability (IOC) can be demonstrated in 8–10 years (~2014). The far-term system includes the functionality of the near-term system with significantly improved implementation and performance relative to the baseline capabilities of the near-term system. In addition, the far-term system provides significantly enhanced functionality through the use of new sensors, new physiological features, and improved data fusion and multi-sensor inference. The capabilities and characteristics envisioned in a far-term system include

1. Tight integration with the FFW PAN, computer and squad radio
2. Dual-use networked sensors including imagers and acoustic sensors
3. Physiological state and performance monitoring
4. Environmental monitoring
5. Derived information including
 - a. Blood volume
 - b. Blunt trauma events and localization
 - c. Burn trauma events and localization
 - d. Respiratory distress
 - e. Sleep quotient
 - f. Metabolic activity level
 - g. Altitude adaptation status
 - h. Integrated CBRN exposures
 - i. Physiological stress index
 - j. Life sign detection

The far-term system will benefit enormously from both advances in technology and the increased knowledge and experience gained through the spiral development of the nearer-term systems. A summary of the WPSM features and capabilities of the far-term system is included in the following figure.

Physiological

- Heart rate & ECG
- Respiration rate/vol
- Blood pressure
- Core & skin temp
- Perfusion
- Speech

Environmental

- Geolocation
- Temperature
- Wind speed
- Humidity
- Solar radiance

Wounds

- Ballistic impact
- Overpressure
- Bleeding



Archived Profile

- Biometrics for authentication
- Height and weight
- Percent body fat
- Cardiovascular calibration
- Strength
- Medical allergies

Thermodynamic/kinematic

- Food intake
- Water intake
- Work load & activity
- Thermal insulation
- Posture

Hazmats

- Nuclear
- Biological
- Chemical

Figure ES.2 – WPSM features and capabilities of the far-term system

Acknowledgments

This study was conducted with the support and encouragement of Dr. Reed Hoyt of USARIEM, and Mr. Roger Masadi of SSC. Dr. John Ames of USARIEM also participated in numerous discussions and meetings.

During the course of the study, Mr. Larry Retherford of MIT Lincoln Laboratory was instrumental in identifying related research and assessing technology maturity. Mr. Michael Shields of MIT Lincoln Laboratory provided technical guidance in the characterization of the low-frequency RF systems.

In the course of our study, we interviewed and met with individuals from a number of commercial companies, government laboratories, and academic institutions. Special thanks are due the following individuals and their respective organizations:

Technologists	Affiliation
Mr. Chris Bunszel & Mr. Dan Cui	Auracomm
Mr. Mike Burns	Science, Math & Engineering, Inc.
Prof. Sundaresan Jayaraman	Georgia Institute of Technology
Prof. Stan Zdonik	Brown University
Mr. Jeff Himawan	Sensatex
Mr. Ira Share & Mr. Steve Ward	Nexan
Mr. Joseph Ting	Foster Miller
Mr. Eric Solliday & Mr. John Gurey	Timex
Mr. Jerry Schultz	NASA
Dr. Estrella Forster	NAVAIR
Mr. Bob Forcier	Beezerbug, Inc.
Mr. Frank McNally	Lear Technology
Andrea Pollick	SRICO
Mr. Michael Scanlon	ARL
Ms. Gayle Grant	CECOM
Dr. Larry Farwell	Brain Fingerprinting Laboratories, Inc.

Table of Contents

Executive Summary	iii
Acknowledgments	ix
List of Illustrations	xv
List of Tables	xix
1. Background, Objectives and Approach	1
1.1. Background	1
1.2. Study Objectives	1
1.3. Current Practice	1
1.4. Approach	2
2. System Concept	3
2.1. What to Sense	3
2.2. When to Sense	7
2.3. How to Sense	7
2.4. Far-Term System Concept	7
2.5. Current Capabilities and Roadmap	7
3. Current Practice in Ambulatory Physiological Monitoring	9
3.1. Overview	9
3.2. Holter Monitor	9
3.3. Nexan System	10
3.4. Vivometric System	12
3.5. Mini Mitter	15
3.6. Body Media, Inc.	16
3.7. FitSense	18
3.8. Timex	19
3.9. Technology Readiness Levels	19
3.10. References	19
4. Current Practice in Sensors	21
4.1. Emerging Standards	21
4.2. Physiological Sensors	22
4.3. Environmental Sensors	28
4.4. Biometric Sensors	32
4.5. Technology Readiness Level	32
4.6. References	33
5. Processor Architectures	35
5.1. Processing Technology Trends	35
5.2. Processing Architectures	37
5.3. Distributed Processor Architecture	38
5.4. References	38
6. Data Exploitation and Information Products	39
6.1. Physiological Constants and Health Information	39
6.2. ECG	39
6.3. Respiration	40
6.4. Life Sign Detection	40
6.5. Thermal Modeling	41
6.6. Data Exploitation and Information Fusion Architecture	42
6.7. References	43

7. Personal Area Networking	45
7.1. Motivation	45
7.2. Technology Overview	45
7.3. Wired Networks	46
7.4. Wireless Networks	48
7.5. Hybrid Networks	57
7.6. References	58
8. User Interface	59
8.1. Alerts	59
8.2. Display Options	59
8.3. Menu Functions	61
8.4. Input Devices	61
9. System Development, Integration and Testing	63
9.1. Near-Term System (IOC)	64
9.2. Integration into Clothing	65
9.3. Sensors	66
9.4. WPAN	67
9.5. Spiral Development Plan	68
10. Near-Term System Concept	71
10.1. Near-Term Constraints	71
10.2. Baseline System	71
10.3. Technology Maturity	75
10.4. Near-Term WPSM Baseline System Concept	77
10.5. References	77
11. Far-Term System Concept	79
11.1. Far-Term Constraints	79
11.2. Capability Envisioned	79
11.3. Sensor Evolution	80
11.4. WPAN	82
11.5. Derived Information Products	82
11.6. Future Force Warrior Integration	83
11.7. Technology Maturity	83
11.8. Far-Term WPSM System Concept	83
11.9. References	84
A. Theory and Performance of Free-Space Magnetic Induction Headset	85
A.1. Introduction	85
A.2. Basic Operation	85
A.3. Theory of Operation	86
A.4. Experimental Verification	89
A.5. Discussion	89
B. Evaluation of Conductive Textiles for Cardiorespiratory Monitoring	91
B.1. Background	91
B.2. Objective	91
B.3. Materials and Methods	91
B.4. Results	93
B.5. Discussion	93
B.6. Conclusions	94
B.7. Suggestions for Future Work	94
C. Related Efforts	95
C.1. SAILSS (FY00–FY07)	95
C.2. Smart Healthcare Management System	96
C.3. References	97

D. Processor and Memory Trends	99
D.1. Moore’s Law and Implications	99
D.2. Performance Metrics	99
D.3. Energy Cost of Processing and Storage	99
D.4. Processing Speed	101
D.5. Storage Capacity	101
E. Detecting Hypovolemia Through Retinal Vasculometry	103
E.1. Introduction	103
E.2. Technical Description	103
E.3. Rodent Measurements	105
E.4. Future Human Measurements	106
E.5. Algorithm Development	107
E.6. Conclusions	108
E.7. References	108
F. WPSM Draft Requirements	109
G. Technology Readiness Levels	113
G.1. Background	113
G.2. TRL Definitions and Acceptance Thresholds	113
G.3. Software-Specific TRL Definitions	116
Acronym Definitions	117

List of Illustrations

Figure No.		Page
ES.1	WPSM baseline system concept	v
ES.2	WPSM features and capabilities of the far-term system	vii
3.1	(a) Hospital ECG monitor (b) Holter monitor in use (c) State-of-the art 5-lead DigiTrak monitor from Zymed	9
3.2	Nexan sensor patch and wireless transceiver	10
3.3	Nonin Xpod oximetry module	11
3.4	Nexan Partner seated in base station	11
3.5	VivoMetric LifeShirt and recorder	13
3.6	Schematic of Vivometric Lifeshirt illustrating sensor locations and options	14
3.7	Mini Mitter ambulatory monitoring component system	15
3.8	Mini Mitter wireless temperature pill, patch and logger	16
3.9	SenseWear Pro Armband	16
3.10	SenseWear embedded sensors	16
3.11	SenseWear transceiver module	18
3.12	FitSense digital foot pod accelerometer and watch	18
3.13	Timex digital FM heart rate and GPS time and distance performance monitoring system	19
4.1	PAM cardiac monitor	22
4.2	Prototype high-impedance Mach-Zender interferometer for measuring biopotentials (after)	23
4.3	Thoracic resistance measurement in Nexan system	23
4.4	Inductive meander lines incorporated in the Vivometric LifeShirt	24
4.5	ADInstruments respiratory belt transducer	24
4.6	Ingestible core body temperature capsule (Jonah™) and multichannel RF receiver and data logger (VitalSense) from Mini Mitter	25
4.7	Alpha Sensors' thermistor skin temperature sensor	26
4.8	VitalSense skin temperature patch and ingestible capsule	26
4.9	Actigraph wristwatch with integral skin temperature sensor. (Precision Control Design, Ft. Walton Beach, FL)	28
4.10	MEMS multisensor: shear, pressure, and temperature sensors in ~1 mm ² (source Tai, CIT)	28
4.11	VioSense miniature laser Doppler	29
4.12	Commercial GPS antenna and receiver	30
4.13	Fujitsu CMOS camera	31
4.14	Fujitsu MBF300 fingerprint sensor array	32
5.1	Illustration of Moore's "Law" for IC complexity	35

5.2	Historical and future projection of the computational complexity available at a fixed price point of \$1000 (after Kurzweil [1])	35
5.3	Energy per instruction for microprocessor and DSP chips [2]	36
5.4	Trend in power density for Intel microprocessors and comparison with the power density characteristic of other familiar systems. [2]	37
6.1	Data exploitation and information product generation architecture	43
7.1	OSI seven layer data network architecture (genesis 1975) and example of elements encountered in the Internet	45
7.2	Conductive Velcro	47
7.3	UWB frequency occupancy spans existing licensed bands and so must conform to FCC power limits (after Leeper [4])	50
7.4	Bluetooth transceiver module	50
7.5	Free-space magnetic induction concept for wireless communication	51
7.6	Field strength versus range for magnetic induction system	52
7.7	Standoff detectability of three PAN technologies	53
7.8	Block diagram of Auracom LibertyLink™ communication chip	54
7.9	Xemics XM1209 38kHz transceiver module	55
8.1	Xybernaut commercial wearable computer with head-up color display	60
8.2	Mock-up of physiological status display for a platoon leader or higher-level command	60
9.1	Spiral development process for near-term and far-term WPSM system insertion	63
9.2	R&D science platform components and uses	64
9.3	Spiral design based on concurrent, iterative development and assessment of subsystem	70
10.1	(a) Infologix ViA II Super Rugged with Caruso Transmeta processor (b) Xybernaut Mobile Assistant V with Celeron ultra-low voltage processor	74
10.2	Near-Term WPSM Baseline System Concept	77
11.1	Retinal scanning head-up color display technology [1]	81
11.2	Gamma radiation detector and alert system	82
11.3	Far-term concept for integration of WPSM into FFW ensemble	84
A.1	Nasaco base unit packaging and circuit board	85
A.2	Endfire configuration for analysis of transmit and receive antenna coils coupling	86
A.3	Coupling as a function of distance. Coil length 0.75", coil radius 0.125"	88
A.4	Broadside coupling geometry	89
A.5	Experimental setup for near-field measurement of Nasaco headset	89
B.1	The textile electrode assembly. Leads were soldered to the copper foil tabs	92
B.2	A cardiac signal recorded with the textile electrode assembly	93
C.1	SAILSS sensor and control ensemble	95
D.1	Evolution of power dissipation in DSP chips normalized by instruction rate	100
D.2	Clock speed for Intel family of processors	101

D.3	Trends in memory and processor circuit density	102
E.1	The Nidek NM100D digital fundus camera and a simplified optical diagram of the handpiece	104
E.2	The raw retinal imagery was examined to locate vascular structures visible in both the baseline and post-bleed images	105
E.3.	Retinal imagery from a 300g HSD rat both before and after the gradual withdrawal of ~30% of the circulating blood volume through tail vein incision	105
E.4	The results of Trial #2 show that although the mean arterial blood pressure decreases following the first blood withdrawal, a subsequent withdrawal caused only a slight reduction in mean arterial pressure but a sizeable reduction in vessel diameter	106
E.5	An LBNP chamber used to study the cerebral hemodynamic response to posturally simulated microgravity, as experienced during spaceflight	107

List of Tables

Table No.		Page
3.1	Zymed DigiTrak Holter Monitor	10
3.2	Manufacturer's Performance Specifications	12
3.3	Manufacturer's Performance Specifications	13
3.4	Summary of Sampling Rates for the Embedded and Peripheral Sensors	17
4.1	Manufacturer's Performance Specifications	25
4.2	Manufacturer's Performance Specifications	31
7.1	IEEE 802.15 Working Groups	49
7.2	IEEE 802.15.4 Preliminary Specifications	49
7.3	Comparison of Representative Implementations of RF and Magnetic Induction Systems	51
7.4	Performance of Three Commercial Near-Field Magnetic Induction Comm. Chips	55
10.1	Comparison of Two Commercial Wearable Computer Systems	74
10.2	Technology Maturity Ranking of Components and Subsystems	76

Background, Objectives and Approach

1.1. Background

This is the final report for a study that was jointly commissioned by the MRMC US Army Research Institute in Environmental Medicine (USARIEM) and the RDECOM Soldier Systems Center (SSC).

1.2. Study Objectives

The Future Force Warrior (FFW) initiative will build upon the Scorpion Integration/Protection Analysis (IPA) and Warfighter Physiological Status Monitoring (WPSM) programs to provide revolutionary physiological and environmental monitoring capabilities for the dismounted soldier. Meeting the goals of Future Force Warrior will require a system integration perspective that brings together technologies that have thus far been demonstrated only independently or are still in the realm of 6.1-6.2 research and development. In the context of this study, MIT Lincoln Laboratory, in concert with USARIEM and SSC personnel, collaborated to define the near- and far-term technologies and system-integration issues that must be addressed to meet the goals for the Future Force Warrior.

This study intentionally centered upon technologies related to physiological status monitoring, and intentionally ignored technologies associated with displays and communications off the body, since these areas are the province of the Land Warrior PM. However, even with this narrow focus, many of the technology concepts and solutions proposed are directly extensible or scalable to the more general requirements associated with FFW.

The objective of the study was to work in close collaboration with USARIEM and SSC to produce near- and far-term system concepts, identify appropriate technologies for near-term demonstration, and define the interfaces to Future Combat System (FCS) and legacy C⁴I systems.

1.3. Current Practice

The goal of integrating physiological sensors and supporting communication, processing, and power on the soldier in a manner that is affordable, reliable, light and simple is extremely challenging. One need only examine the state of the art in ambulatory medical monitoring to realize that existing approaches are deficient in a number of aspects:

1. Cost – Commercial real-time ambulatory medical monitoring systems (e.g., hospital or home wireless monitoring of respiration, ECG, SpO₂) cost in excess of \$25K per system
2. Size, weight, and power – Excluding the sensors, the mobile components (comm link and data archiving unit) of the smallest commercial system weigh 400 g, with a volume of 230 cm³, a wireless connection range of less than 50 m, continuous data archival capability of 24 hours, and non-real-time post-processing and analysis

3. Intrusiveness – Commercial systems require placement of adhesive electrodes
4. Immunity to motion artifacts – Motion introduces noise in the sensors and commercial systems have limited or no real-time processing to correct or suppress artifacts
5. Scalability to multiple users – Commercial systems are not designed to operate with multiple wearers in close proximity, so RF interference may occur and disrupt reporting of information when wearers come into close proximity
6. Scalability in range of operation – Commercial systems operate in unlicensed ISM bands or designated medical bands with maximum ranges of 50–150 m between wearer and wired base station

In addition to commercial developers of ambulatory medical monitoring equipment, other sources informally surveyed for physiological status monitoring technology include NASA, all three service branches, and sports and health training organizations.

1.4. Approach

On a limited scale, some success in physiological monitoring of athletes and individuals engaged in vigorous activity has been demonstrated. However, achieving the physiological monitoring goals associated with FFW and WPSM will require breaking new ground and will be possible only through careful integration and optimization of the component subsystems.

With this in mind, a three-phased approach has been taken in this study:

1. Identify state-of-the-art sensor, processing, communication, and power technology
2. Develop a conceptual design and demonstration strategy for a near-term system
3. Identify essential research and development needed to address technology shortfalls in the evolutionary to the objective system

Each of the technology areas is assessed in a separate chapter and an attempt is made to assign technology readiness levels (TRL) to each of the categories. Unless otherwise noted, the TRL assignments are only estimates based on available information. TRL definitions, adapted from NASA, are included in Appendix G.

System Concept

Appendix F includes a draft specification for the WPSM system that defines the near-term priorities and requirements for insertion of physiological sensing in the Land Warrior system. In this chapter, a longer-term view is developed concerning the role of physiological sensing and the desired types of sensing. This long-term vision shapes the technology investigation and reporting in subsequent chapters. To the degree that the resulting system capabilities appear achievable and valuable, their inclusion in an updated WPSM specification may be appropriate.

Chapter 9 outlines a recommended technology development and deployment roadmap that is aimed at realizing the existing draft specifications for the WPSM, while establishing a course and direction that will lead to full exploitation of physiological sensing and full integration of the WPMS subsystem with other sensors and networks developed for the FFW.

2.1 What to Sense

There are clear benefits to sensing as much physiological information as possible on every soldier and even clearer cost and technology barriers to implementing comprehensive sensing. For the purpose of this study, only non-intrusive sensing methods and only physiological parameters for which some prior use benefit has been established by the medical community or the military are considered.

In addition to physiological parameters, there is value in measuring parameters that characterize the environment in which the soldier is immersed, as well as parameters that characterize the interface between the soldier and the environment. Consequently, we identify four categories of sensor measurements related to physiological status and health forecasting: physiological, natural environment, hazardous environment, and metabolic.

There is also a fifth class of sensor measurements, biometrics, which is not directly related to physiological status and forecasting, but is important to authenticate and profile the user. Systems for biometric identification and authentication may also derive benefit from leveraging physiologic sensors, thus minimizing the excess weight and power burden relative to a stand-alone biometric sensor. Furthermore, in the broadest sense, biometrics includes certain calibration constants specific to each individual, such as height, weight, and body-mass index.

2.1.1 Candidate Physiological Parameters to Sense

This sensing category consists of parameters that can in principle be continuously monitored from body measurements and do not require knowledge of the environment or activity of the soldier. The physiological status parameters that can be sensed by

nonintrusive means, in approximate order of importance rather than ease of sensing, include

1. Heart rate
2. Electrocardiogram
3. Respiration
4. Core temperature
5. Hydration
6. Blood pressure
7. Brain function
8. Oxygenation
9. Skin temperature

Note that the order of importance is conditioned upon the specific goals of the sensing. For example, if the primary goal is life-sign detection for remote triage, sensing blood pressure and brain function are high priorities. However, if the primary goal is to avoid heat-related injuries during training, core temperature and hydration are of primary importance. Heart rate, ECG, and respiration are listed as priority sensing functions because of their intrinsic value across a range of sensing goals and applications, and because of the maturity of algorithms for interpreting this information.

2.1.2 Candidate Environmental Parameters to Sense

Although the primary focus of the study is technology for assessing physiological and cognitive status, there is ample reason to consider various types of environmental sensors as well. Environmental sensing falls into two categories: microclimate determination and harmful substance detection and classification. The relative importance of sensing various hazardous substances is scenario driven. In scenarios for which nuclear, chemical, or biological hazards may be encountered, detecting and quantifying the concentration and distribution of these materials is of utmost importance. The relative importance of microclimate and geolocation sensing is somewhat scenario-dependent also, with the following approximate order of importance:

1. Geolocation and orientation
2. Temperature
3. Wind speed
4. Humidity
5. Solar radiance
6. Visual imagery of the environment

Unlike the environmental parameters listed above, hazardous substances are not naturally occurring and may be intentionally released from weapons of mass destruction or inadvertently released as a consequence of attacks on manufacturing, storage, or weapons stockpiles. Consequently, this class of environmental sensing is assigned a separate category.

2.1.3 Hazardous Environment and Materials Sensing

The classes of hazardous substances that may be encountered on the battlefield, either due to intentional release from a weapon of mass destruction or unintentional release as a consequence of bombing and combustion of manufacturing and storage facilities, is large. A taxonomy of the hazardous substances and a comprehensive survey of sensing technologies is beyond the scope of this study.

The primary classes of hazardous substances for which sensing is desired are

1. Nuclear and radiological
2. Biological
3. Chemical

Hazardous substances can be conveyed by any one of several mechanisms including contaminated air, water, food, or surfaces. Many weapons of mass destruction are based on aerosol release, since food and water can presumably be tested and avoided if contaminated, whereas breathing is an essential function that cannot be deferred for any length of time. Unlike nuclear and chemical agents, biological agents can also be conveyed through a vector such as an infected arthropod.

An important question in establishing the feasibility of placing particular CBRN sensors on an individual is whether the objective of the sensing is “detection-to-treat” or “detection-to-warn.” Since some chemical agents usually have an immediate adverse effect on the individual, detect-to-warn sensors that sense continuously and provide a low-latency real-time alert for these agents are the only rational choice. While the effects of exposure to radioactive materials may take longer to manifest themselves, options for treatment after exposure are limited, and therefore a real-time alert is again the sensible option. However, for most biological agents, prophylaxis within 24 hours of exposure can be effective in mitigating the consequences, and detect-to-treat sensors are valuable.

To the degree that the potential threats are known and reliable sensors exist, the requirements for sensing hazardous substance are similar, regardless of the specific nature of the substance:

1. Detect and identify the hazard
2. Alert the user
3. Record the levels of exposure

We do not give further consideration to the sensing technologies for hazardous substances since this is outside the domain of physiological status monitoring. However, we note that the data from such sensors should be available to the decision and risk-analysis software of a WPSM system, and the network and protocol standards developed for physiological monitoring could easily be adopted to support the integration of hazard warning sensors. Furthermore, the data collected from environmental monitoring sensors worn by individual warfighters is an important source of information for use in forecasting the concentration and movement of aerosolized threats.

2.1.4 Candidate Metabolic Parameters to Sense

In the WPSM implementation we envision, the physiological parameters identified in section 2.1.1 provide a continuous assessment of the soldier’s current state. When combined with

the environmental parameters identified in section 2.1.2, measurement of certain thermodynamic and kinematic parameters provides a basis for predicting the evolution of the soldier's physiological status in the future. The key metabolic (thermodynamic and kinematic) parameters to sense are

1. Fuel intake (food and water)
2. Work load
3. Thermal insulation
4. Posture

Unlike the previous two categories, these parameters are very broad in scope and difficult to quantify with a single measurement device or methodology. For example, accelerometers are an obvious means of measuring kinematic activity. However, relating kinematic activity to work load is a challenging problem. For example, a commander giving a pre-mission briefing might move his arms and hands frequently, creating a lot of "activity." A soldier stacking artillery shells might move his arms and hands at roughly the same rate, producing the same level of apparent "activity," but accomplishing more work, consuming more calories, and generating more heat. Therefore kinematic motion sensors alone are inadequate to characterize the activity from a metabolic perspective. Combinations of sensors such as accelerometers and weight load sensors, or accelerometers and thermal gradient sensors, are required to estimate workload and level of metabolic activity.

Another example of measurement complexity is establishing the thermal resistivity or conductivity of the layered ensemble of clothing and equipment worn by a soldier.

2.1.5 Candidate Biometric Parameters to Sense

In order to calibrate some of the physiological measurements, and in order to forecast physiological status, user-specific calibration information is required such as height, weight, and body-mass index. In addition, some aspects of medical history may also be required, particularly in support of combat casualty care and triage. Since this information is either static or changes slowly with time, it can be coded into an electronic "dog tag" or personal information chip (PIC), and read by the WPSM system to initialize models and measurement processes. Baseline parameters include

1. Blood type
2. Height
3. Weight
4. Body mass index
5. Cardiovascular performance parameters
6. Medical allergies

A closely related sensing function is to authenticate the identity of the user by means of biometric sensing. The electronic "dog tag" must contain sufficient biometric information to verify the holder is the authorized user. Biometric information with potential application to authentication includes

1. Finger and/or thumb print
2. Iris or retinal patterns (eye features)
3. Voice features

2.2 When to Sense

Given a desired set of physiological parameters that are to be sensed, the sensing functions should occur uniformly or regularly over time, with adjustment of the sampling frequency to reflect available energy storage and relative importance of the information. Similarly, environmental sensing should occur continuously, with adjustments based on context.

2.3 How to Sense

One of the most important attributes in a taxonomy of physiological sensing is intrusiveness, both in the physical sense and in the sense of distraction to the wearer. The emphasis of this study is in physically non-intrusive sensors and in sensors that can ultimately be integrated into existing elements of the combat uniform and personal equipment. The goal is to make the sensing so unobtrusive that the user is unaware of its existence, a so-called “wear and forget” sensor suite.

2.4 Far-Term System Concept

The long-range vision for a warfighter physiological status-monitoring system is one in which the sensors are integral to the essential clothing and equipment that all soldiers are required to wear or carry during training and combat. Consequently, the sensors, communication network, and associated real-time processing and analysis must be carefully packaged and integrated to produce a system that is extremely lightweight, reliable, and durable, requiring insignificant amounts of energy relative to the other functions such as the squad radio. In part, high reliability implies the means for autonomous calibration and built-in testing of the sensors, personal area network, and processing.

2.5 Current Capabilities and Roadmap

Chapters 3 and 4 provide an overview of the current state of commercial ambulatory monitoring systems and sensor subsystems respectively. Chapter 5 presents an overview of processor and memory technology, emphasizing the anticipated performance improvements and the trade-off between centralized and distributed processing. Chapter 6 introduces the primary data products available through physiological status monitoring, connecting these end products to specific sensor needs and data rates. Chapter 7 examines the potential networking technologies available to support these sensor and data rates, as well as the trade-offs between wired and wireless communication links.

Based on the desired data products and the current and future technologies identified in Chapters 3–7, Chapters 8–11 propose both baseline and enhanced systems, with recommended technologies to implement near-term and far-term systems.

Current Practice in Ambulatory Physiological Monitoring

3.1 Overview

There are many examples of commercial and research sensors for monitoring various physiological status parameters such as heart rate, activity, skin temperature, etc. This chapter provides an overview of several systems that perform physiological status monitoring of ambulatory subjects (i.e., self-contained mobile monitoring and collection systems). The systems included were chosen either because they implement complex monitoring functions, such as ECG, or because they endeavor to integrate several monitoring functions into one package. The majority of the systems also include specialized analysis software to aid in the interpretation and, in some cases, clinical analysis of the data. However, the majority of commercial systems are oriented toward sampling and archiving of real-time physiological data, such as an ECG, with post-processing and analysis of the data by a desktop computer. The systems presented here are representative, and there is no intent to imply this is a comprehensive survey of all such systems, nor does inclusion imply any expressed endorsement of a product or vendor by the authors. Furthermore, while several of the systems have received 510k certification and are used in clinical trials, others we describe are aimed at sports and consumer health markets and have not been considered or approved for medical use.

3.2 Holter Monitor

A Holter monitor is the terminology commonly used to describe a variety of ambulatory systems for 24-hour ECG data collection. There are many different implementations of Holter monitors. A typical example of a hospital unit is shown in Figure 3.1a. The Holter monitor employs conventional clinical silver silver-chloride gel-coated adhesive electrodes.

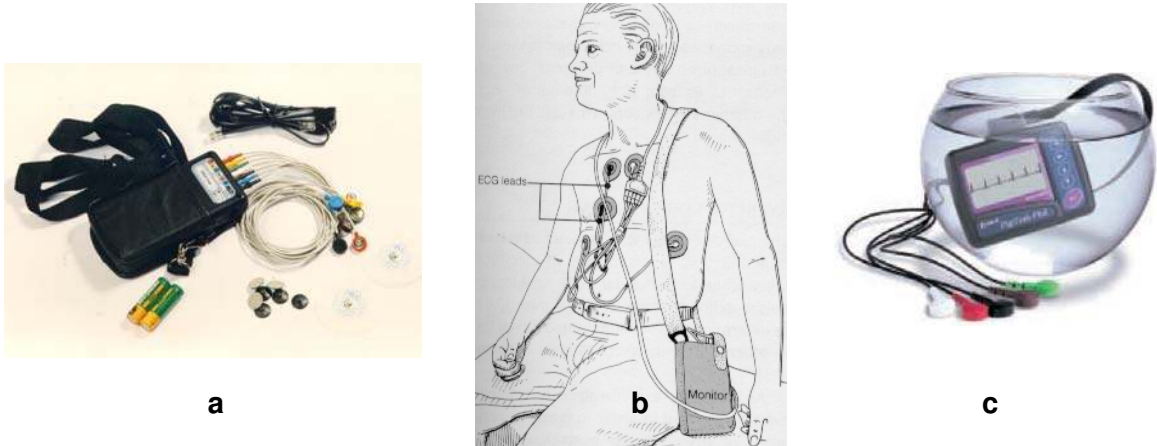

Figure 3.1 – (a) Hospital ECG monitor (b) Holter monitor in use (c) State-of-the art 5-lead DigiTrak monitor from Zymed

A trained clinician must generally position the electrodes, and they are connected to the sampling and data archival unit via wires. The electronics package is typically worn around the neck and/or shoulder as shown in Figure 3.1b.

Small, low-power commercial Holter monitor systems are evolving rapidly. Although not intended for use in environmental extremes, FDA certification includes rigorous criteria regarding tolerance to shock, vibration, and fluid exposure. Performance parameters for a representative unit, the Zymed DigiTrak shown in Figure 3.1c, are summarized in Table 3.1. While the size, weight, and power numbers are attractive, these and other Holter units are wired data collection systems and have no provision for wireless linking or real-time processing (i.e., monitoring) of the ECG data.

Table 3.1 –Zymed DigiTrak Holter Monitor

Parameter	Value
Volume	90 cm ³
Weight with batteries	90 g
Operating temperature	0° – 45° C
Sampling rate	175 Hz
Battery endurance	48 hours
List price	\$2245

3.3 Nexan System

Nexan, Inc., was a privately held British company with US headquarters in Alpharetta, GA. In September 2001, they were granted FDA 510k approval for an ambulatory “Clear Path” monitoring system that measures and archives several physiological parameters of the wearer for up to 24 hours. The 24-hour duration is set by data archival limits rather than the battery endurance. Initial applications of the sensor and software analysis system include monitoring and diagnosis of sleep disorders. In the summer of 2002, the parent company located in the UK experienced financial difficulties and filed for bankruptcy, but the US office remains open for business as do the subcontractors who supply components for the system.

3.3.1 System Overview

The system consists of five main hardware components:

1. A patented disposable sensor patch that is manufactured in four different sizes
2. A module that clips onto the patch, digitizes the measured signals and transmits them to an archival unit via an ISM band wireless link
3. A wireless archival unit that receives the digitized data and stores up to 30 hours of raw data
4. A base station in which the PDA is placed to retrieve the archived data and send it to an analysis workstation, either by telephone modem or direct Ethernet connection
5. A workstation for automatically processing the recorded data to identify anomalies that relate to various medical disorders.



Figure 3.2 – Nexan sensor patch and wireless transceiver

The wearable components of the Nexan system are pictured in Figure 3.2.

A key element of the system is the sensor patch that incorporates gel-coated, silver, silver-chloride electrodes pre-wired and positioned within the adhesive patch. The sensor patch makes positioning and attachment of the electrodes relatively simple for a non-medical professional to perform. The patch includes sensors for a two- or three-electrode ECG, as well as bidirectional transmit and receive sensors for measuring respiration rate and estimating tidal flow. The patch is intended to be worn for a 24-hour collection period and is comfortable and fairly resistant to dislocation resulting from movement and perspiration.

A data acquisition module with wireless link operating at 914 MHz (ISM band), clips onto the disposable patch midway between the clavicle and shoulder. Two AAA alkaline batteries housed in the connector of the disposable patch supply power to the module. In addition to acquiring data from the sensors embedded in the patch, the module includes a port for collecting data from a peripheral oximeter. The electronic module for interfacing the oximeter sensor to the Sender wireless transmitter is pictured in Figure 3.3.



Figure 3.3 – Nonin Xpod oximetry module



Figure 3.4 – Nexan Partner seated in base station

The wireless transmitter, termed the Sender, links to a portable data assistant, termed the Partner. The Partner can record ECG, respiration, and SpO₂ data for up to 24 hours. Data is archived in a 32MB flash memory. The Partner can be carried by the individual or placed in a stationary location within 50m range of the Sender worn on the individual. The Partner includes two different event buttons that can be pressed by the user to mark significant events. The significance of the two markers is assigned during the testing. For example, if the user felt light-headed, he could be instructed to press button one, and to press button two if he felt chest pains. These time marks can then be correlated with events observed in the physiological data. The data collected by the Partner is uploaded to analysis software through a base station. The Partner and base station are pictured in Figure 3.4.

The data analysis software resides on a Windows™ workstation and includes provisions for searching for events, summarizing anomalous behavior, and creating various types of visual summaries.

3.3.2 Performance Summary

The salient performance parameters of the Nexan system, as described in the application for 510k certification, are summarized in Table 3.2

3.3.3 Strengths

In terms of application to WPSM evolution, the Nexan system provides the ability to simultaneously acquire and analyze two- or three-lead ECG and respiratory information.

The sensors can be applied by a nonspecialist, and the data can be automatically analyzed once uploaded to a workstation.

The sensor and software system can be used in current form to detect and analyze sleep apnea and other sleep disorders. Sleep apnea can occur in otherwise healthy individuals with serious impact on cognitive performance during normal waking hours.

The system can also be used in limited numbers for nominal 24-hour periods of status monitoring. A near-term application of interest to USARIEM is detecting altitude sickness during mountain training.

3.3.4 Modifications for field use

The Nexan system is designed and marketed for commercial medical applications and clinical trials. In terms of military use, the current system can be used on a limited scale to collect and analyze physiological data on soldiers during training exercises. Experimental use of the system during training exercises would also provide more information on how robust the sensor attachment and processing software are to motion artifacts and environmental extremes.

Table 3.2 – Manufacturer’s Performance Specifications

Parameter	Value
ECG	
Bandwidth	.05 – 85 Hz
Leads	2 active plus ground
Electrodes	Ag/AgCl
Heart rate range	30 – 250 beats/minute
Heart rate accuracy	± 3 beats/minute
Respiration	
Method	Thoracic impedance
Respiration range	0-72 breaths/minute
Respiration accuracy	± 2 breaths/minute
Electrodes	Ag/AgCl
Skin Temperature	
Thermistor	Alpha Sensors 400 series
Range	25 – 45 °C
Accuracy	± 2 °C
Wireless Link	
Modulation	Digital FSK
Frequency	433 MHz or 916 MHz
Output power	50mV at 3m
Batteries	
Type	2x1.5 V (sender unit)
Endurance	72 hours

Without expanding the scope of the current sensing functions, a number of modifications are needed to make the system suitable for field tests and potential transition to an operation capability. These improvements are technically achievable but are not necessarily part of Nexan’s current commercial development strategy. Specific improvements are discussed in Chapter 10.

3.4 Vivometric System

VivoMetrics is a privately owned company established in 1999 to focus on ambulatory collection and subsequent analysis of physiological data. VivoMetrics received 510k certification for their LifeShirt, pictured in Figure 3.5, for which they hold a number of patents [1].

3.4.1 System Overview

The system consists of five main hardware components:

1. Adhesive gel-coated carbon electrodes for ECG sensing
2. A sensor vest that includes embedded sensors for respiratory monitoring, posture sensing and connections to ECG electrodes
3. A control/display/recording unit that supports real-time display of physiological status information
4. Ethernet connection
5. Software for processing the recorded data to identify anomalies that relate to various medical disorders.

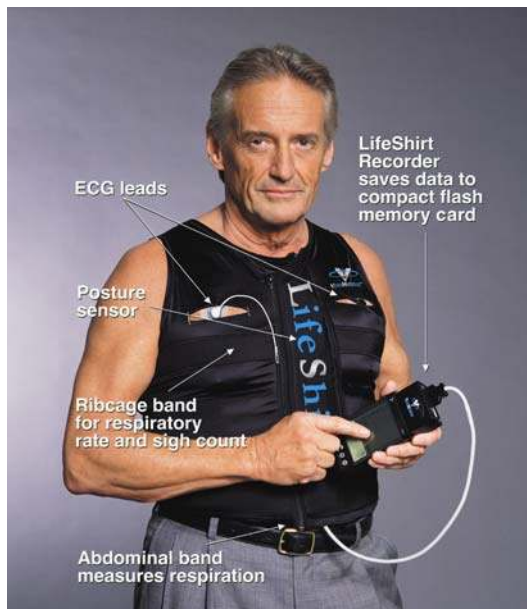

Figure 3.5 – VivoMetric LifeShirt and recorder

Table 3.3 – Manufacturer's Performance Specifications

Parameter	Value
ECG	
Bandwidth	<100 Hz
Leads	1 active plus ground
Electrodes	Carbon
Heart rate range	30 – 250 beats/minute
Heart rate accuracy	± 5 beats/minute
Respiration	
Method	Inductive plethysmography
Respiration range	0-150 breaths/minute
Respiration accuracy	± 2 breaths/minute
Accelerometer	
Axes	2
Data products	Posture and activity
Accuracy	± 2 °C
Batteries	
Type	7.4V
Endurance	8 hours

Sensors for blood pressure and SpO₂ can be interfaced to the baseline system as well. The Components of the VivoMetric system are represented schematically in Figure 3.6.

3.4.2 Performance Summary

The salient performance parameters of the Vivometric system, as described in the manufacturer's literature, are summarized in the Table 3.3.

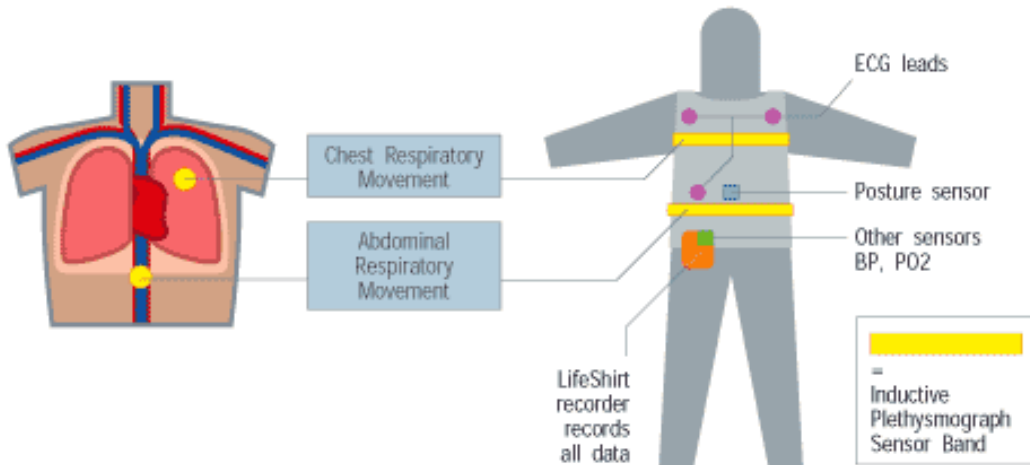

Figure 3.6 – Schematic of Vivometric Lifeshirt illustrating sensor locations and options

3.4.3 Strengths

The Vivometric LifeShirt received FDA certification in April 2002, and patents for the unique technologies associated with the shirt have been obtained.

The inductive plethysmography sensors and associated processing algorithms appear to provide a robust method for measuring respiration rate and tidal flow and for diagnosing breathing anomalies. The inductive plethysmography sensor consists of a sinusoidal meander line that encloses the chest cavity or the abdominal cavity. As the chest or abdominal cavity expands and contracts, the mutual inductance of the meander line changes, providing an indication of respiration rate. Properly calibrated, the change in mutual inductance can also be used to estimate the total volume change during each respiration cycle. In-phase and out-of-phase expansion and contraction of the chest versus abdominal cavity (paradoxical breathing) can also be used as an indication of certain types of breathing abnormalities.

The inductive plethysmography sensor could be integrated into a soldier's undershirt to achieve the goal of a non-intrusive, easy-to-install sensor.

A variant of the technology that is under development for future generations of the life shirt is a neck inductive plethysmograph. A neck inductive plethysmograph would allow monitoring of the following information:

1. Swallowing
2. Respiration
3. Carotid pulse

3.4.4 Modifications for field use

The requirement to manually affix ECG electrodes to the correct locations on the body and to then connect them to the LifeShirt via wire connections is a significant impediment to field use for at least two reasons:

1. The LifeShirt is significantly bulkier than the standard issue undershirt raising issues about comfort and thermal impact.
2. The wire connections between the electrodes and the LifeShirt are potential sources failure in the physically demanding, dynamic battlefield environment.

The weight of the system includes 382 g for the recorder, 260 g for the shirt, and 116 g for cabling. The total weight of 760 g exceeds the initial weight allowance in the WPSM performance spec of 453 g (1 lb).

3.5 Mini Mitter

Mini Mitter is an established company with decades of product development and marketing experience. Mini Mitter designs, develops, and manufactures equipment and medical devices for ambulatory monitoring of physiological and behavioral parameters in both humans and animals. As shown in Figure 3.7, Mini Mitter offers a component monitoring system that includes the following elements [2]:

1. Data cable for uploading data from the logger to a computer
2. A hybrid wireless/wired data logger
3. Software for logger configuration and data reduction and analysis
4. A family of activity monitors with integral accelerometer and data logger
5. Wired temperature sensors
6. Wireless heart-rate monitor
7. Event button to mark events of interest

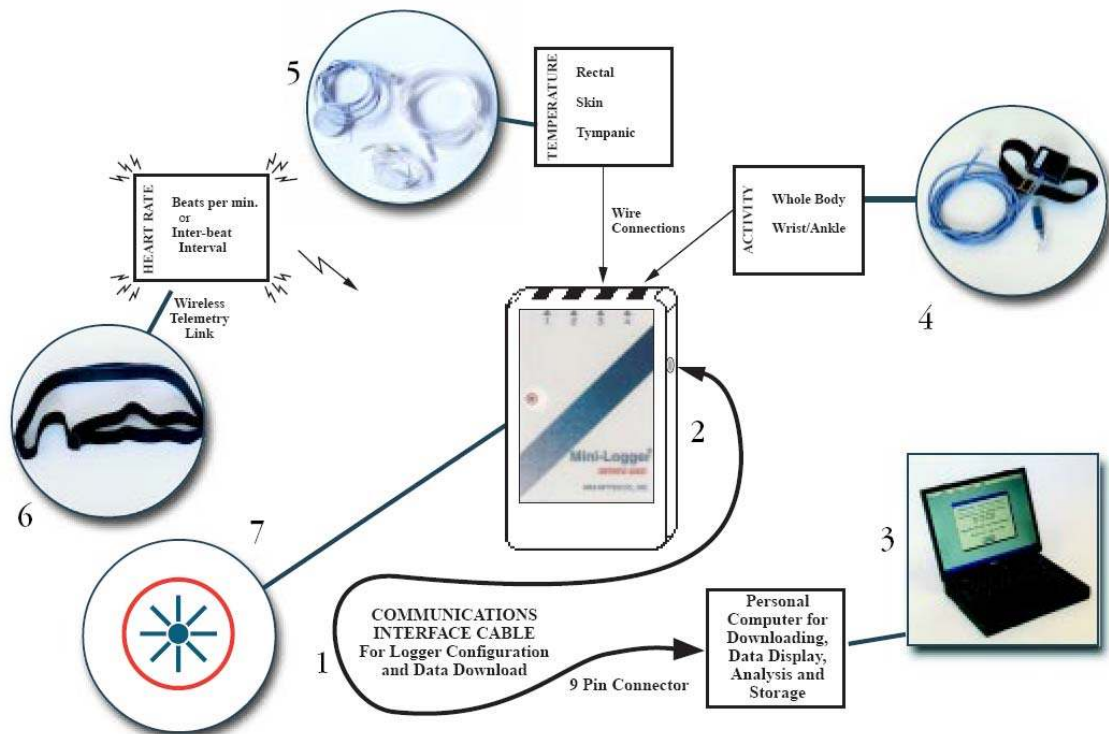

Figure 3.7 – Mini Mitter ambulatory monitoring component system

Mini Mitter has also developed a wireless temperature sensor and data logger. The temperature sensor comes in an ingestible pill for measuring core temperature as well as in an adhesive patch for measuring skin temperature. The Mini Mitter *VitalSense* data logger is shown in Figure 3.8. The datalogger supports up to 10 wireless temperature sensors, including any mix of the ingestible capsule and the adhesive skin temperature sensors, collecting and displaying data as well as supporting uploading to a computer through a wired interface.

3.6 Body Media, Inc.

Body Media is start-up company built around a web-based health and sports monitoring concept. An armband termed *SenseWear* monitors and archives vital signs for subsequent transmission to a personal computer via wireless link. The SenseWear armband is worn on the arm over the triceps as shown in Figure 3.9

From the computer, information is either downloaded to a web site or to a resident software tool where it may be combined with dietary information entered by the user to produce lifestyle “quality” and “balance” metrics. The company is working with researchers at the University of Pittsburgh Medical Center to adapt the technology to address certain medical ailments and conditions, such as sleep disorders, obesity, and stress.

3.6.1 System Overview

The system consists of three main hardware components [3]:

1. An armband sensor with integral wireless transmitter
2. A receiver interfaced to a data archival PC
3. A charging cradle

3.6.1.1 SenseWear Armband

The armband, pictured in Figure 3.10, weighs 82 grams and includes a 2-axis accelerometer and sensors to measure heat flux, skin temperature, ambient temperature near the body, and galvanic skin response. At default sample rate settings, the armband can be worn for up to 72 hours without recharging the battery and can store up to 14 days of continuous data. The sensing modes and sampling rates are summarized in Table 3.4.



Figure 3.8 – Mini Mitter wireless temperature pill, patch and logger



Figure 3.9 – SenseWear Pro Armband



Figure 3.10 – SenseWear embedded sensors

Table 3.4 – Summary of Sampling Rates for the Embedded and Peripheral Sensors

Sensing Mode	Max Rate (Hz)	Abs Diff. (Hz)	Moving Avg (Hz)
X Acceleration	32	32	32
Y Acceleration	32	32	32
Heat flux	32	32	32
Skin temperature	32	32	NA
Ambient temperature	32	32	NA
Galvanic skin response	32	32	32
Heart rate (chest strap)	32	NA	NA
Event time stamping	Millisecond accuracy	NA	NA
On/off body	32	NA	NA

The unit also includes haptic and audio alerts to provide feedback regarding target performance levels. According to company literature, the sensors can be used to derive the following types of information:

1. **Accelerometer** - The accelerometer in the Armband is a two-axis micro-electro-mechanical sensor (MEMS) device that measures motion. The motion can be mapped to forces exerted on the body and hence energy expenditure. By taking into account gravity, algorithms have been developed to predict the context in which the Armband is being worn.
2. **Heat Flux** - The proprietary heat flux sensor in the Armband is a robust and reliable device that measures the amount of heat being dissipated by the body. The sensor uses very low thermally resistant materials and sensitive thermocouple arrays. It is placed in a thermally conductive path between the skin and the side of the armband exposed to the environment. A high gain internal amplifier is used to bring the signal to a level that can be sampled by the microprocessor located in the Armband.
3. **Galvanic Skin Response** - Galvanic skin response (GSR) represents electrical conductivity between two points on the wearer's arm. The Armband's GSR sensor includes two hypoallergenic stainless steel electrodes integrated into the underside of the armband connected to a circuit that measures the skin's conductivity between these two electrodes. Skin conductivity is affected by the sweat from physical activity and by emotional stimuli. GSR can be used as an indicator of evaporative heat loss by identifying the onset, peak, and recovery of maximal sweat rates.
4. **Skin Temperature** - Skin temperature is measured using a highly accurate thermistor-based sensor located on the backside of the Armband near its edges and in contact with the skin. Continuously measured skin temperature is linearly reflective of the body's core temperature activities.
5. **Near-Body Temperature** - The near-body temperature sensor measures the temperature of the cover on the side of the Armband.

The use of these sensors in conjunction with simple body measurements, including gender, age, height, and weight, allow for estimation of energy expenditure. However, an evaluation of the Armband and associated analysis software conducted by researchers at Virginia Tech reveal that the accuracy of the Armband is a function of both the individual and the activity. In general, the energy-expenditure estimates for resting individuals showed good agreement with indirect calorimetry (IC) measurements. However, for cycle ergometer tests, the energy expenditure estimates *averaged* over all test subjects showed good agreement with IC, but the individual errors were large [4].

3.6.1.2 SenseWear Transceiver Module

The SenseWear armband also has the capability to receive digital information from peripheral devices, such as a heart-rate monitor, oximeter, etc., over a wireless link. Interfacing to peripheral sensors requires installation of a compatible transceiver in the peripheral sensor. The SenseWear transceiver is shown in Figure 3.11. The transceiver operates at 916.5 MHz using ASK modulation with a maximum bit rate of 56 kbps and a range of 1–30 m, depending upon the bit rate, environment, and antenna. The transceiver draws 16 mA in operation at a nominal voltage of 3V, for a power dissipation of 50 mW. The transmit power is <1 mW.



Figure 3.11 – SenseWear transceiver module

3.6.1.3 InnerView Research Software

A Java-based research software tool is available that enables adjustment of data sampling as well as analysis and profiling of data. Data is saved in XML format and can be exported in CSV format for easy import into third-party spreadsheets and analysis programs.

Planned enhancements to the software system include calculation of heart-rate variability, energy-expenditure states, sleep states, and context states (ambulatory, driving, etc.).

3.7 FitSense

FitSense Technology markets a product for runners which utilizes a foot-mounted digital accelerometer to estimate stride and distance traveled during running or walking. The accelerometer, shown in Figure 3.12, measures and analyzes acceleration 500 times a second and transmits the resulting information to a wristwatch for display and archival. The watch also supports an interface to a heart-rate monitor based on a carbon-electrode chest strap.



Figure 3.12 – FitSense digital foot pod accelerometer and watch

Once calibrated to the individual's stride, FitSense claims an accuracy of 98% in estimating distance for normal running and walking conditions [5].

The accelerometer and integrated processor and data link operate for 3 months on a CR2032 coin cell.

3.8 Timex

Timex also offers a sports watch that interfaces to an FM digital heart-rate (R-wave) monitor (HRM). The watch apparently uses a Motorola 6805 microcontroller and free-space magnetic induction wireless link.

The Timex heart rate monitor is one of the first digital HRMs. Digital HRMs are less susceptible to interference and cross talk. Furthermore, since the heart rate is computed at the sensor, the rate of transmission to the watch (base station) can be set at a fixed rate to conserve power. The Timex system transmits the heart rate once every two seconds.

Timex has also developed a performance monitor, shown in Figure 3.13, that records not only heart rate but location as determined by a GPS receiver [6]. The location information enables the estimation of speed and distance over time, providing an absolute measure of performance. The speed and distance are calculated once every second and transmitted to the wristwatch display once every 3.5 s. The system uses a free-space magnetic induction link, termed the BodyLink, to connect up to 4 devices at low data rates. The manufacturer quotes a battery life of 2 years for the monitor.



Figure 3.13 – Timex digital FM heart rate and GPS time and distance performance monitoring system

3.9 Technology Readiness Levels

The systems described in this chapter are all commercially available. The Nexan, VivoMetric, and Mini Mitter systems are FDA certified for the functions they perform. Other systems provide physiological data for sports or fitness monitoring but are not intended for medical use. In terms of the markets these systems serve, they each deserve a TRL 9 designation since they are all commercially available products. However, adaptation of these technologies to the WPSM mission introduces a more hostile environment, requires compatibility with other sensor types, and requires real-time data reduction and interpretation. For this reason, the appropriate TRL designation for these system elements when applied to the WPSM environment is in the range of 5–6, implying that the basic technology elements exist and have been integrated to a level that supports testing in controlled environments. The utility of these technologies has yet to be demonstrated in a realistic field environment, and the elements of the various systems are not directly compatible in terms of the sampling rates, data formats, or communication links.

3.10 References

- [1] www.vivometrics.com/site/index.html
- [2] www.minimitter.com
- [3] www.bodymedia.com/index.jsp
- [4] M. L. Fruin, J. W. Rankin, “Validity of a multi-sensor armband in estimation rest and exercise energy expenditure,” *Medicine and Science in Sports and Exercise*, 2004 pp. 1063–1069.
- [5] www.fitsense.com
- [6] www.timex.com/spd/index.html

Current Practice in Sensors

There are five classes of sensor to be considered for physiological status monitoring. The primary class consists of sensors that directly monitor physiological parameters. The second class consists of sensors that monitor the natural environment. The third class consists of sensors for monitoring hazardous environments. The fourth, and least established, class consists of sensors that measure exchanges between the individual and the environment, such as fluid intake and output, and expired gases. The fifth class of sensor consists of biometric sensors that provide user authentication and calibration information.

Current practices, as well as conjectured applications for each of these classes of sensor, are discussed in this chapter. Representative examples of commercially available sensor technology are provided for illustrative purposes. An exhaustive survey of commercial sensors for each type of sensing was not undertaken, and there is no intent to imply the sensors described are the best available sensors for the particular sensing tasks. The goal of this chapter is to identify the range of sensing options available and the benefits that each class of sensor offers to the overall goal of quantifying physiological status and forecasting impending problems.

4.1. Emerging Standards

The Institute of Electrical and Electronics Engineers (IEEE) has been developing a set of standards for creating digital networks of smart sensors. This set of standards, labeled 1451, will eventually consist of four parts. Only one part has been officially approved to date. The four parts progress hierarchically from the lowest level interfaces among different analog and digital transducers (1451.4) through the collation of the signals (1451.3) to the final digital presentation of the sensor data (1451.2) and the communication between the devices on the sensor network (1451.1).

The approved 1451.2, "A Smart Transducer Interface for Sensors and Actuators," describes the interface between a sensor module, which consists of a single transducer with one or more channels, and a device that controls the sensor module and is also attached to the sensor network. The standard is divided into two parts: the physical interface and the definition of a transducer electronic datasheet, or TEDS. The TEDS contains device identification and characterization data, as well as a means with which to specify the translation from the transducer's raw output to a meaningful representation.

The 1451 standard set, if successful, will reduce the number of protocols defined by each sensor manufacturer. However, the standard exacts a cost, imposing many unnecessary requirements and constraints on the system developer. For example, 1451.2 specifies the exact number of data lines and the timing diagrams for the signals on the lines to each transducer. The TEDS contains data fields that may only be useful in exceptional circumstances. The effort required to implement a node design that fully conforms to the 1451.2 standard represents a large cost and latency during the development and assessment of potential sensor technologies.

Additionally, 1451 includes standards for interoperability within the nodes themselves. The evolution of these standards should be tracked, and the standards should be considered in the design and implementation of a WPSM system. While it is likely that the full standard will be too costly to implement in WPSM, portions of the standard may be of sufficient benefit to incorporate in a WPSM implementation.

4.2. Physiological Sensors

4.2.1. Heart rate

There are a variety of commercially available heart-rate sensors similar to the one described in Section 3.8. These sensors employ several different techniques to measure heart rate, and they utilize both RF and free-space magnetic induction to transmit the heart-rate information to a nearby device, typically a wristwatch, for archival or display. Older versions of heart-rate monitors simply transmit an analog pulse for each detected heartbeat. Consequently, these systems are prone to mutual interference when multiple systems are in close proximity. Newer versions of the commercial sensors transmit detected heart rate as a digital signal and use modulation techniques that allow multiple users in close proximity without interference.

A significant issue encountered with the use of commercial heart rate sensors to monitor warfighter physiological status is long-term comfort. The sensors are designed to be worn for short periods during exercise, typically positioned around the chest by an elastic band. The band may become uncomfortable with extended use and may ride up or down in response to torso motion and bending. Tailoring the fit to the individual and integrating the sensor into an undershirt may address some of the comfort and location stability issues. However, an alternative is to employ an ECG sensor to obtain not only heart rate, but also a two- or three-lead electrocardiogram as well.

4.2.2. Electrocardiogram

Clinical electrocardiograms, as well as ambulatory monitoring systems, typically employ silver, silver-chloride electrodes in conjunction with a conducting gel to sense the small amplitude electrical signals associated with heart contractions. As many as nine electrodes are employed to obtain a detailed electrocardiogram for clinical analysis of heart irregularities. The objectives of collecting ECG on soldiers in the field is not to perform a detailed clinical diagnosis, but to provide improved understanding of health status or to aid in life-sign detection. As a by-product, an ECG can provide heart-rate information, and can also be used to provide input to the blood-pressure determination algorithm described in Section 4.2.8. For this application, as well as for some clinical analyses, a two-lead electrocardiogram is adequate when collected with silver, silver-chloride electrodes that are coated with conducting gel and appropriately positioned and taped to the skin.



Figure 4.1 – PAM cardiac monitor

Techniques for dry-electrode ECG have been developed, although performance is typically inferior to adhesively-secured, gel-coated electrodes. Dry electrode non-adhesive cardiac monitors are available commercially, but assume a clinical technician is available to properly position and hold in place the electrode probe as shown in Figure 4.1.

To develop an acceptable system for performing an ECG on soldiers in the field, the following issues must be addressed:

1. Electrodes must not require physical taping to the skin or application of conductive gel
2. ECG must not be sensitive to position errors of the electrodes
3. ECG must be able to tolerate or identify invalid motion-induced sensor noise and artifacts

In our survey, we were unable to find examples of any ECG sensing systems that simultaneously satisfy the three important requirements listed above. However, we believe that a system can be developed to satisfy these requirements. As an indication of the potential for developing such a sensor, we offer the R&D effort by SRICO, which has been funded in part by MRMC. The SRICO effort is focused on the development of high-impedance electrodes for electrophysiological measurement. Their sensor, dubbed *Photrode*, employs a Mach-Zehnder interferometer modulated by the low-frequency biopotential signal. The Photrode requires a CW reference laser input supplied via fiber and provides the modulated output signal over a second fiber. A prototype Photrode, which has been used to date only in laboratory tests, is shown in Figure 4.2. In laboratory tests, detection of an ECG signal through a subject's shirt by a Photrode has been demonstrated. These experiments offer hope for a dry contact ECG sensor that could be embedded in an undershirt. However, more research is needed to quantify the performance of such a sensor in a dynamic (motion kinematics) environment.

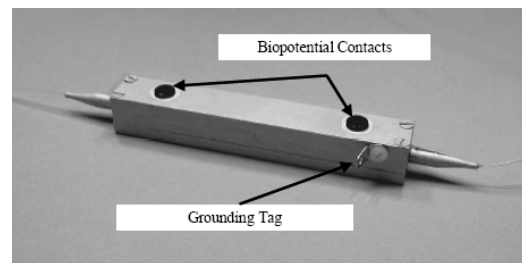

Figure 4.2 – Prototype high-impedance Mach-Zehnder interferometer for measuring biopotentials (after)

4.2.3. Respiration

There are a variety of sensing mechanisms that can be employed to measure respiration. The predominant aspects of respiration to be measured are the tidal volume and rate. The two classes of measurement technique identified during the study are

1. Measure the change in electrical impedance of the thorax as the lung volume changes
2. Measure changes in the electrical properties of an elasticized band that encircles the chest cavity and, optionally, the abdomen or throat

The Nexan system incorporates the first method to measure respiration rate as illustrated in Figure 4.3.

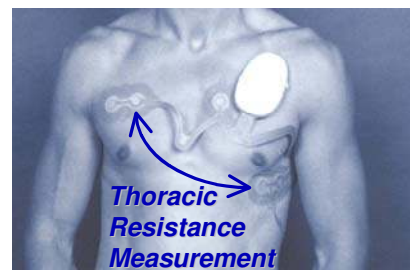

Figure 4.3 – Thoracic resistance measurement in Nexan system

The Vivometric system incorporates the second method by placing a sinusoidal meander line in an elasticized band circling the measurement cavity, as shown in Figure 4.4. By measuring the change in mutual inductance as the band stretches and contracts, the respiration rate can be measured and the volume change can be estimated. The Vivometric system places a second band around the abdomen to improve the volume estimate and to compare the phasing of the chest and abdominal expansion and contraction. This approach allows automated detection of certain types of abnormal breathing patterns. An advanced version of the Vivometric LifeShirt system employs a similar elasticized band around the neck to measure changes in the cross-sectional area of the neck. There are five classes of physiological activity that affect the cross-sectional area of the neck:

1. Respiration
2. Carotid artery pulses
3. Jugular venous traces
4. Movement of the neck
5. Swallowing

Note that speech, drinking, and eating produce cross-sectional area variations through a combination of neck movement and swallowing.

In addition to the resistive and inductive methods of measuring volume changes, methods based on piezoelectric effects have been developed. Figure 4.5 shows a respiratory belt from ADInstruments for use in measuring thoracic or abdominal circumference changes associated with respiration. The transducer is a piezoelectric diaphragm placed in compression between two elastic strips. Stretching of the elastic band induces a strain in the piezoelectric sensor that in turn generates a voltage change. The sensitivity of the device is 4.5 mV/mm with a dynamic range of 20 mV to 400 mV.

4.2.4. Core temperature

Core temperature is a critical measurement for predicting onset of heat exhaustion or hypothermia and for initializing thermal models of the body to predict heat and water loss.

4.2.4.1. Ingestible capsule

The WPSM currently uses an ingestible capsule to monitor core body temperature. Since the capsule is carried internally, it achieves thermal equilibrium with the internal organs and provides an accurate measurement of core body temperature. The temperature is obtained by measuring the frequency of a temperature-sensitive RF oscillator contained in the capsule.

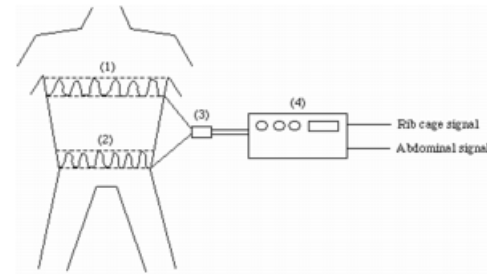

Figure 4.4 – Inductive meander lines incorporated in the Vivometric LifeShirt



Figure 4.5 – ADInstruments respiratory belt transducer

The capsule and data logger, produced by Mini Mitter, are shown in Figure 4.6. The disadvantages of this approach are that a pill must be ingested every 48 to 72 hours.



Figure 4.6 – Ingestible core body temperature capsule (Jonah™) and multichannel RF receiver and data logger (VitalSense) from Mini Mitter

Table 4.1 – Manufacturer's Performance Specifications

Parameter	Value
Monitor/Logger	
Size	120 x 90 x 25 mm
Weight	200 g
Battery life	10 days
Ingestible Capsule	
Size	8.7mm dia x 23mm
Weight	1.6 g
Battery life	10 days
Temperature Sensing	
Range	25–50 °C
Accuracy	± 0.10 °C
Update rate	0.066 Hz
Calibration	automatic
Number of concurrent sensors	≤10
Max RF link range	1 m

The Mini Mitter *VitalSense* monitoring system consists of an ambulatory data logger unit and disposable temperature sensors. In addition to the ingestible capsule, a waterproof, hypoallergenic, dermal patch skin temperature sensor is available (see Figure 4.8). The data logger can concurrently receive temperature signals from up to ten ingestible or patch sensors and display the temperature on a LCD display. The information is stored for later uploading to a computer by means of a wired interface. A wireless connection is under development.

Table 4.1 provides a summary of the manufacturer's technical specifications and performance data for the *VitalSense* core temperature monitoring system.

4.2.4.2. Tympanic membrane measurement

In clinical situations treating victims of hypothermia, excellent agreement between oral temperature and tympanic membrane has been demonstrated. The correlation between core temperature and tympanic membrane temperature over a range of environmental extremes is less well understood. However, assuming torso skin temperature and ambient environmental temperature are available, it may be possible to correlate a properly collected tympanic membrane temperature with core body temperature and develop a calibration curve to translate tympanic membrane temperature to core temperature. This approach requires field validation against the existing ingestible capsule. A tympanic membrane sensor could be integrated with the acoustic ear piece of a soldier radio.

4.2.5. Skin temperature

4.2.5.1. Technology

Very small skin temperature sensors, such as Alpha Sensors' micro series shown in Figure 4.7, are available commercially and achieve high accuracies, on the order of 0.1°C. The small size and low cost of skin temperature sensors allows them to be placed in more than one location. The overall size and cost of skin temperature sensing is driven not by the

sensor itself, but by the circuitry required to interrogate the sensor and report the results over a PAN.

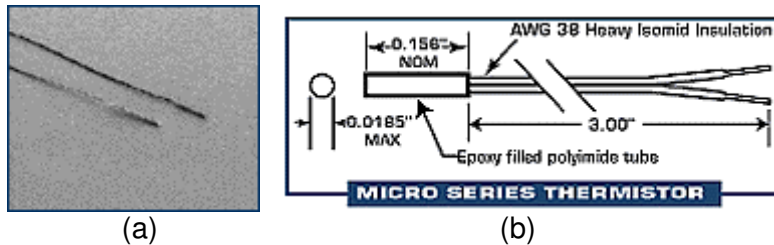

Figure 4.7 – Alpha Sensors' thermistor skin temperature sensor



Figure 4.8 – VitalSense skin temperature patch and ingestible capsule

The Mini Mitter VitalSense system includes an adhesive skin temperature sensor with RF link to the monitor/data logger pictured in Figure 4.6. The accuracy and battery life of the adhesive patch is the same as the ingestible capsule, and the skin sensors and ingestible capsules can be operated concurrently with up to ten sensors per monitor. The adhesive patch sensor weighs 7.5 g, is 57.2 mm in diameter and 5.3 mm thick. The adhesive patch is shown in Figure 4.8, along with the ingestible capsule for reference.

4.2.5.2. Placement

Ideally skin temperature sensing should be performed on both the torso, to assess heat loss, as well as on the extremities, to detect dangerously low temperatures in winter conditions. Temperature sensors can easily be integrated with other sensors or equipment, and the data combined with other sensor data for transmission over the PAN. For example, a temperature sensor could easily be incorporated in the Nexan patch or in the elasticized region of the Vivometric inductive plethysmography belt. A sensor could be embedded in a wristwatch to measure temperature at the extremities, as well as embedded in clothing, such as gloves or socks.

4.2.6. Hydration

Complete knowledge of an individual's hydration state by noninvasive means requires that one know the hydration state at some point in time (i.e., initial condition) and then be able to monitor the intake and output of fluids. Water intake consists predominantly of consumption of free water as well as pre-formed water in foods. Less significant sources are metabolic (manufactured) water and insensible water absorption from humidity. Quantitative studies of water intake and excretion in free-living individuals are rare and typically rely on the use of isotopically labeled water and comprehensive measurement of urine production [1].

If the warfighter is in a field operation and constrained to drink only from a canteen and to eat only MREs, the fluid intake can be estimated fairly accurately since the water content of MREs is controlled and the fluid intake from a canteen can be monitored. The WPSM has developed a "drink-o-meter" which accurately measures water intake by means of a flow meter on the soldier's canteen. The moisture intake from foods can be accurately determined in advance for prepackaged foods and accounted for in the field by swiping packaged foods over a bar-scanner or RFID tag reader prior to consumption. If the water used to hydrate prepacked meals is always drawn from the warfighter's canteen, accurate accounting of fluid intake can be maintained.

However, in situations in which food and fluids may be consumed from sources other than the warfighter's canteen and MREs, fluid intake becomes more difficult to track. The possibility exists to add throat microphone to the neck inductive plethysmograph and use the

combination of acoustic and inductive signals to help track intake of fluids and food. The acoustic and inductive signals associated with drinking fluids could be correlated against the drink-o-meter on the canteen to develop a calibration factor for estimating fluid intake when the canteen is not used. This approach would require an algorithm to identify the “swallow signature” associated with fluid intake.

The more difficult measurement is to accurately determine the output of water. In a healthy individual, the principal sources of water loss are respiration, perspiration, and urination. In desert conditions, as much as 1.5 liters of fluid per hour may be lost through perspiration and respiration. The combined evaporative loss can be estimated from microclimate measurements, thermal resistivity of clothing, and measurements of the individual’s activity level and respiration rate. The accuracy that can be achieved with such estimates, and their utility in predicting hydration state, is unproven.

4.2.7. Brain function

Sensing brain function in the form of an electroencephalograph (EEG) offers the opportunity to more accurately establish mortality, and also to better assess physiological status. EEGs are primarily used as clinical tools and employ adhesive sensors and conductive gel. Electrodes implanted under the skin would offer a stable means of measuring the weak EEG signals, but violate the mandate of nonintrusive sensing. An alternative is a multi-electrode EEG sensor cap that could be sized to the individual to minimize motion artifacts and maintain relatively close contact between the sensor and the scalp. The Photrode described in Section 4.2.2, has been successfully applied to collect EEG data and is a candidate for the sensor. As with ECG, the major challenge is in dealing the motion artifacts and extreme environmental conditions encountered in a combat environment. Clearly, information from other types of sensors must be used to ascertain whether the conditions for reliable EEG measurements exist. For example, EEG measurements might only be useful (uncorrupted by artifacts) when kinematic motion is low, but this may also be the most valuable time for collecting EEG information. For example, EEG information collected during rest periods could help determine sleep state. EEG information collected subsequent to a wounding event could help determine viability.

4.2.8. Blood pressure

In a clinical environment, blood pressure is measured using a compression cuff. This approach is not suitable for instrumenting soldiers. A more appropriate method is to measure the latency between the systolic impulse at the heart and the arrival of the pressure wave at an extremity of the body. The velocity of the pressure wave is proportional to the average elastance of the vascular wall, which is in turn related to the average blood pressure. For the pulse transit time technique to work, each individual must be calibrated in terms of the length of extremity and cardiovascular parameters. Posture and limb position may also affect the measurement. Time synchronization must be provided between the ECG measurements used to define the onset of the systolic impulse and the extremal sensor used to measure the peak of the velocity wave.

4.2.9. Oxygenation

Oxygenation monitoring is slightly more difficult to perform than electrocardiography; however, this is offset by the ability to both assess lung function and monitor cardiac rate simultaneously. Oxygen saturation (the fraction of hemoglobin that is bound to oxygen) is easy to measure using optical spectroscopy. Pulse oximetry exploits the pulsed nature of arterial blood flow, along with the existence of an isosbestic point in the near-infrared spectral band, to determine the fraction of oxygenated hemoglobin in arterial blood. This is

commonly performed by transillumination of a fingertip using two or more LED sources and a single silicon photodetector. Since the probe must generate its own flux, power dissipation of ~50 mW is required during a measurement. Probe placement is important since it must be able to illuminate a region of the body that has sufficient subsurface arterial vasculature to generate a pulsatile signal. Although fingertip monitoring is impractical in a tactical setting, other monitoring locations, such as the toes or exposed regions of the wrist and ankle, are also possible. Higher-power optical sources can be used to transilluminate the scalp and skull to perform oximetry in the cortical region of the brain. Cortical oximetry provides the most direct assessment of viability since the brain is extremely vulnerable to even short periods of hypoxia.

4.2.10. Activity Monitoring

Accelerometers mounted in a wristwatch can be used to sense limb motion and provide a crude measure of metabolic activity. Analysis of the acceleration can provide further information regarding the vigorousness of the activity. USARIEM currently employs a combination accelerometer and skin temperature sensor in a wristwatch to estimate sleep state and develop a sleep score. The wristwatch sensor, termed an actigraph, is shown in Figure 4.9. A sleep score (activity/inactivity) is computed in 15 increments over the past 24 h using Cole Kripke algorithm [6]. Commercial wristwatch actigraphs exist that incorporate multi-axis accelerometers as well as light sensors.



Figure 4.9 – Actigraph wristwatch with integral skin temperature sensor. (Precision Control Design, Ft. Walton Beach, FL)

4.3. Environmental Sensors

Environmental sensors are easier to develop than physiological sensors. Some of the desired sensors, such as temperature, exist already in compact implementations that could be easily adapted for use as body-worn microclimate sensors. Each of the desired sensor types is discussed in the following sections, and an example of the current state of the art is provided. Since environmental sensors are typically statically deployed in the environment, research is needed to establish the optimum locations on the body for microclimate sensors and to develop algorithms that utilize information about body motion and mobility to properly interpret the information from the environmental sensors.

4.3.1. Temperature

4.3.1.1. Technology

There are a variety of technologies that have been developed to provide real-time temperature measurements. Figure 4.10 shows an example of a prototype MEMS sensor that incorporates a shear stress sensor, a pressure sensor, and a temperature sensor all in one package approximately 1 mm x 1 mm. The principal performance issues for temperature sensors revolve around calibration and linearity of the sensor. The small size of the sensors allows placement in multiple locations.

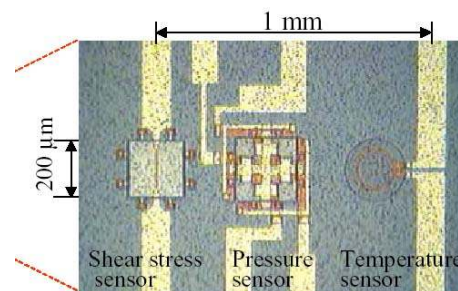

Figure 4.10 – MEMS multisensor: shear, pressure, and temperature sensors in ~1 mm² (source Tai, CIT)

4.3.1.2. Placement

Ambient atmospheric temperature measurement requires placing the temperature sensor as far from the body heat source as possible and in a location that is unlikely to be covered by cold-weather clothing. The temperature sensor could be mounted in any essential piece of equipment or clothing that is worn outside the outer layers of clothing.

Combined with a skin contact temperature sensor, placement of a temperature sensor on the external surface of a wristwatch provides a means for measuring the temperature gradient near the body and using this temperature gradient to compute heat loss.

4.3.2. Wind Speed

4.3.2.1. Technology

A variety of techniques exist for measuring wind speed, and it is the wind speed relative to the individual that is relevant in terms of impact on physiological status. For a soldier-worn wind sensor, moving parts should be avoided. Two possible techniques for measuring wind speed without moving parts are hot-wire anemometry and laser Doppler anemometry. Both techniques are susceptible to fouling in the extreme environments encountered in field operations, and experimentation is needed to determine which of these or other sensing methodologies will be sufficiently reliable. Ultrasonic phase-sensing anemometry would eliminate most of the contamination and fouling concerns. However, both the ultrasonic and laser anemometry may create vulnerabilities in terms of detectability of the wearer at close ranges.

Hot-wire anemometers have been manufactured using microelectromechanical systems (MEMS) fabrication techniques. Polysilicon hot-wire anemometers only 10 μ m long and 1 μ m wide have been demonstrated.

In steady state, the anemometer follows King's law,

$$IR = hA(T_w - T_a)$$

Where I is the current through the wire and R is the resistance of the wire, T_w is the wire temperature and T_a the ambient temperature. For a wide range of velocities, the convection heat transfer coefficient, h , can be related to the instantaneous velocity given the heat transfer area of the wire, A . The problem is that environmental contamination of the device may modify the effective transfer area, A , requiring recalibration.

Laser Doppler anemometry has been in use since 1964. In laser Doppler anemometry, two laser beams are converged at a point in space forming interference fringes (alternating patterns of dark and light). Tiny particles carried by the wind flow will pass through it, scattering light at very high frequency. A lens then collects the light as oscillation. From this oscillation, a very precise measurement velocity of the particles can be made, and the flow velocity deduced. A miniature laser Doppler anemometer manufactured by VioSense Corporation is shown in Figure 4.11 [8]. Of course, this Doppler anemometer only measures the component of velocity normal to the beam. Multiple sensors or spatial-temporal averaging over time would be required to estimate the total wind velocity. Since the sensor is active, it may also produce an unacceptably high optical signature for use in combat.



Figure 4.11 – VioSense Miniature laser Doppler

4.3.2.2. Placement

Ideally the wind speed sensor should be placed on the top of the helmet where wind flow would not be obstructed in any direction. Alternatively, the wind sensor can be placed circumferentially around the brim of the helmet with four quadrant sensors. The largest wind reading from the quadrant sensors can be taken as the best estimate of the relative wind speed.

4.3.3. Solar Radiance

4.3.3.1. Technology

Calibrated solar radiance sensors have been developed for environmental monitoring and weather forecasting applications.

For use in physiological status monitoring, precise calibration is not required. Therefore, a solar cell can be employed in a dual-use mode to monitor solar radiance while generating electrical power for trickle charging a battery. If a solar cell is used as the solar radiance sensor, the current generated by the solar cell is measured, scaled for cell voltage, and divided by a constant involving the quantum efficiency of the solar cell to obtain an estimate of the solar radiance.

4.3.3.2. Placement

As with a GPS antenna, the solar radiance sensor should have a clear view of the sky from zenith to the horizon or ground-level obstructions. Two possible sites for location of the solar sensor are on the helmet or on or near the shoulder. If placed on the helmet, the solar cell could be used to charge a battery integral to the helmet. If placed on the shoulder, a solar radiance sensor must be placed on each shoulder to ensure that head shadowing does not bias the measurement. With two or more radiance sensors, the highest reading is chosen as the indication of the individual's solar radiance exposure.

4.3.4. Humidity

4.3.4.1. Technology

A variety of technologies are available for measuring humidity. Capacitive humidity sensors are the most preferred type of humidity sensors, satisfying the requirements of high sensitivity, short response time, small hysteresis, low cost, and low power consumption. Polyimide is the most frequently used humidity sensitive material because of its varying dielectric constant against relative humidity, which is almost linear.

4.3.4.2. Placement

Ideally, multiple humidity sensors should be placed in a variety of locations to provide data for forecasting algorithms. Placement of a humidity sensor on the interior, lower edge of the helmet provides a location sheltered from direct exposure to rain but sampling the humidity envelope around the soldier. Humidity sensors can also be embedded in clothing and wired to a central location where sampling and reporting occur. For example, humidity sensors might be embedded in the sleeves and torso panels of upper-body fatigues.

4.3.5. Geolocation

4.3.5.1. Technology

Outdoors, with a clear view of the horizon, GPS provides geolocation information to 3 m or better. The power dissipation of commercial systems is approaching 25 mW. A 72-hour mission with the GPS receiver on continuously would require



Figure 4.12 – Commercial GPS antenna and receiver

an AA-size battery for power. However, if the GPS duty factor is reduced to 20% and the power is augmented with solar cells, required battery capacity becomes relatively insignificant.

As shown in Figure 4.12, the antenna size currently drives the overall footprint of GPS receivers. For geolocation in buildings and urban environments, or in jungle canopy where GPS satellites are not within line of sight, dead-reckoning algorithms must be used, with position updates from GPS or other reference sources when they are available.

The import for WPSM is that FFW geolocation requirements are likely to result in the availability of low-power inertial navigation systems. For example, a 1999 paper reports on a miniature INS and accelerometer concept small enough to be embedded in the heel of a boot with sufficient accuracy to maintain 3D geolocation information inside a building for a period of several hours [7]. An ancillary benefit of the existence of such embedded INS/accelerometer systems is the availability of data to improve estimates of metabolic activity. For example, acceleration data can be used to establish whether an individual is at rest, walking, or running, and the change in geolocation with time provides an indication of the work function, or energy expenditure.

4.3.5.2. Placement

In order to achieve the best possible performance, the GPS antenna should have a clear view of the sky from zenith to the horizon or to whatever ground-level obstructions exist. Two possible mounting sites for the GPS antenna are on the helmet and on or near the shoulder. Shoulder placement is currently preferred in Land Warrior. Placing the GPS antenna on the helmet requires either mounting a GPS computer and battery power in the helmet as well, or else routing a signal cable from the antenna to a GPS processor located on the body.

4.3.6. Visible Imagery

4.3.6.1. Technology

Visible imagery is a rich source of information about not only the environment but also the user, including outward indications of physiological stress. Historically, digital imagers have not been considered for individual use primarily because of the size, weight, power, and cost. For integration into a WPAN, bandwidth is also a consideration.



Figure 4.13 – Fujitsu CMOS camera

However, active pixel imagers, fabricated using standard CMOS processes, are an emerging technology that overcomes many of the previous barriers to integration in the soldier ensemble. Fujitsu has announced a color imager with a footprint of less than 8 mm x 8 mm in size and a power consumption of only 20 μ W in standby mode. The imager, shown in Figure 4.13, provides a digital output over flex cable that conforms to the common intermediate format (CIF) compression standard for

Table 4.2 – Manufacturer's Performance Specifications

Parameter	Fujitsu MB86S02 CMOS Camera
Size	7.8 x 7 x 5 mm
Optics	55° f/2.8
FPA	357 x 293
Dynamic range (bits)	8
Frame rate (Hz)	15
Effective data rate (Mbps)	12.6
Operating power (mW)	30
Standby power (μ W)	20
Energy per bit (nJ)	2.4
Cost	\$40

videophones. The specifications for the CMOS imager are shown in Table 4.2. While the average data rate is too high for most WPANs, imagery can be buffered and transmitted at a lower rate to provide information about the soldier's current situation to commanders. Depending upon where the imager is mounted, the imagery could be of the surrounding scene, or it could be an image of the soldier, providing visual information about an injury. The small size, low standby power, and small footprint suggest that multiple imagers could be integrated into the warrior's ensemble and remotely queried for information on demand.

4.3.6.2. Placement

There are many options for placement of imagers of this small size. If power is available from the helmet, four of these cameras could be mounted around the periphery of the helmet to provide non-overlapping quadrant coverage. It would not be difficult to provide a single-axis of elevation slew that would allow the camera to be pointed outward to provide imagery of the environment or downward to provide imagery of the soldier. The down-looking position would also prevent standoff detection of the imager by a laser interrogator exploiting retro reflection.

4.4. Biometric Sensors

Biometrics is the term commonly used to refer to a variety of methods for machine recognition of an individual based on immutable physical characteristics of the individual. In the context of this study, we use the term biometrics to also include individual physiological calibration constants such as body weight and cardiovascular condition. These quantities change with time, but at a slow enough rate that they can be monitored on an annual or semiannual schedule and updated as needed.

One of the more technically advanced areas of biometric sensing is fingerprint sensing. Several companies offer capacitive-based, solid-state fingerprint acquisition devices, and many other companies offer optical scanning devices. A Fujitsu MBF300 ball grid array CMOS sensor is shown in Figure 4.14. It is currently the smallest device of its class, measuring 4.3 mm x 14 mm x 1.2 mm. The package contains a 256 x 32 pixel sensor array producing a 500 DPI resolution image. Standby power is on the order of 50 μ W, and operating power is on the order of 50 mW. The unit interfaces over a standard peripheral interface (SPI) requiring only 6 wires.



Figure 4.14 – Fujitsu MBF300 fingerprint sensor array

However, Matsumoto [4] has shown that many of the fingerprint chips can be defeated with artificial fingerprints made from readily available materials. Hence, a fingerprint sensor should be viewed as a quick and convenient method of cooperative identification of the user rather than a secure authentication device. To provide a counter to the use of artificial fingerprints, researchers are investigating methods to sense “aliveness” concurrently with the fingerprint information by exploiting other measurable features such as galvanic skin response and blood flow.

4.5. Technology Readiness Level

The objective of this chapter is to provide an overview of the variety of sensor technologies available for incorporation into a WPSM. This chapter is by no means a comprehensive survey of sensing technologies, and most of the sensors and sensing technologies discussed are available in the commercial market. Therefore, from the point of view of commercial availability, the sensors for WPSM can be considered to be mature TRL level 5

component technologies. The challenge to incorporate these sensor technologies into a robust WPSM is threefold. First, in some cases, the sensor technology must be hardened to withstand the harsh environment associated with combat. Second, methods for placement of the sensors, including incorporation into combat uniform, must be devised that simultaneously provide reliable sensing and user comfort (wear and forget). Third, the sensors must be interfaced to power and data links to create a plug-and-play network capability. When viewed in terms of their integration into a robust system, the sensor technologies are generally at a TRL level of 3–4.

4.6. References

- [1] A. Raman, et al., “Water Turnover in 458 American Adults 40–79 Years of Age,” *Am. J. Physiol. Renal Physiology*, February 2004, pp. 394–401.
- [2] J.D. Woodward, Jr. et al., *Army Biometric Applications*, RAND Arryo Center, 2001.
- [3] —. *Opportunities in Biotechnology for Future Army Applications*, Board on Army S&T, NRC, National Academy Press, Washington, 2001.
- [4] T. Matsumoto, et al., “Impact of Artificial ‘Gummy’ Fingers on Fingerprint Systems,” *SPIE Proceedings Optical Security and Counterfeit Deterrence Techniques IV*, Vol 4677.
- [5] S. A. Kingsley, S. Sriram, A Pollick, J. Marsh, “Revolutionary Optical Sensor for Physiological Monitoring In the Battlefield,” *SPIE Proceedings*, Vol. 5403, 12–16 April 2004.
- [6] R.J. Cole, D.F. Kripke, W. Gruen, D.J. Mullaney, and C.J. Gillin. “Automatic sleep/wake identification from wrist activity,” *Sleep*, 15(5), 1992, pp. 461–469.
- [7] J. Elwell, “Inertial Navigation for the Urban Warrior,” *SPIE Proceedings*, Vol. 3709, 1999, pp. 196–204.
- [8] G. D. Byrne, S.W. James, R.P. Tatam, “ A Single-Headed Fibre Optic Laser Doppler Anemometer Probe for Measurement of Flow Angles,” *Measurement Science and Technology*, Vol. 15, 2004.

Processor Architectures

5.1. Processing Technology Trends

For over four decades, integrated circuit technology has doubled in performance every 18 to 24 months. This trend is likely to continue for at least the next 10 years. Figure 5.1 illustrates the impact of integrated circuit technology circuit density of Intel CPUs. This trend in circuit density, which is closely coupled to chip performance, was first articulated by former Intel CEO Gordon Moore, and is largely responsible for the exponential growth in computer processing capability.

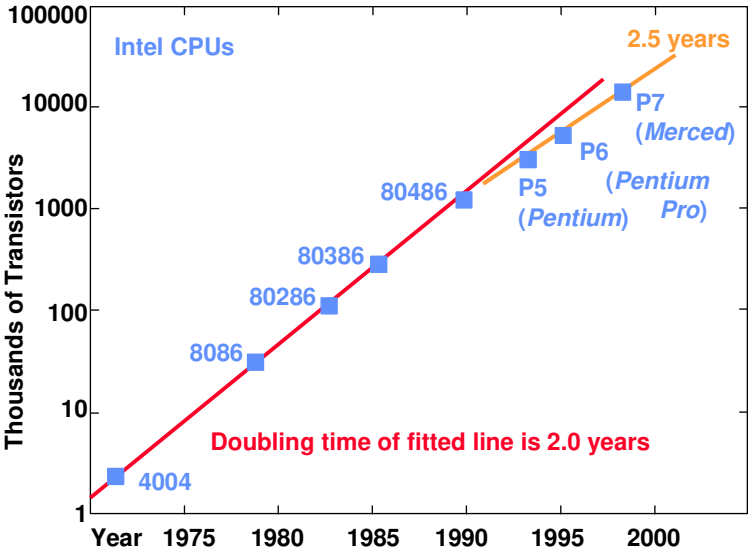

Figure 5.1 – Illustration of Moore’s “Law” for IC complexity

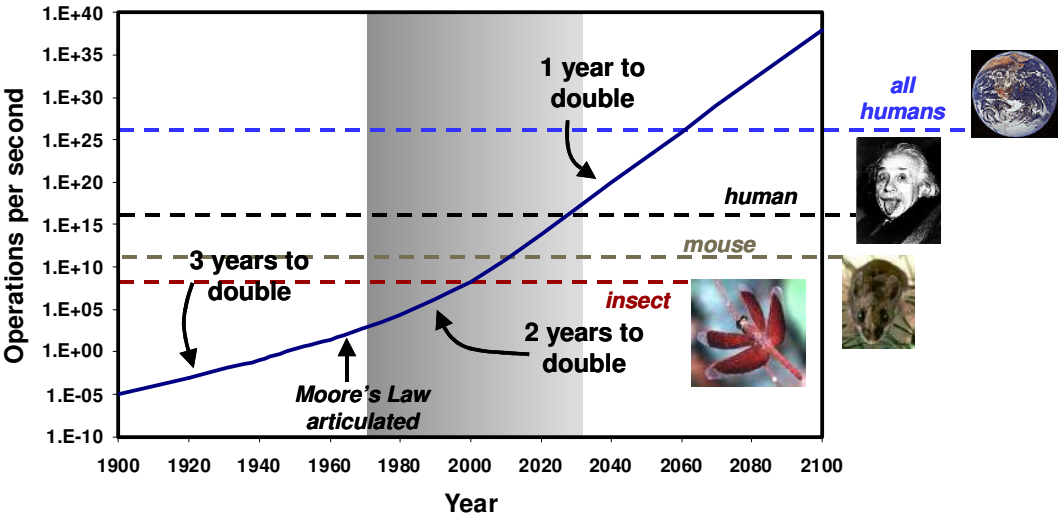

Figure 5.2 – Historical and future projection of the computational complexity available at a fixed price point of \$1000 (after Kurzweil [1])

Figure 5.2 is a combination of historical data plus a future prediction illustrating the computational complexity that can be purchased for a fixed will price point of \$1000. Note that if the conjectured growth in processing prevails for another 20 years, a \$1000 computer will provide a concurrent operation rate equivalent to all of the neurons in a human brain firing concurrently. The important point for WPSM/FFW is that computation and memory is expected to continue the historically observed exponential improvement in performance and cost for the foreseeable future, with the result that the computational complexity available in low-cost computers will enable sophisticated data analysis and reasoning tasks.

However, the most important issue for physiological status monitoring now and in the future is the energy consumption required by the processor and memory. The trend in processor energy per instruction has followed a similar improvement curve to that of chip density, with the energy per instruction dropping by 2x in slightly less than 24 months, as shown in Figure 5.3.

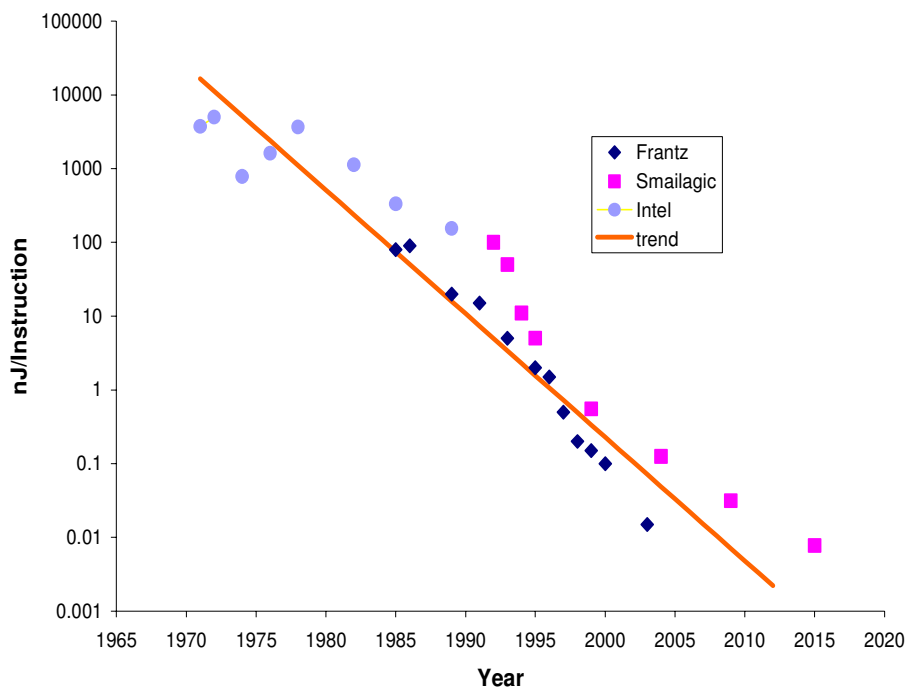

Figure 5.3 – Energy per instruction for microprocessor and DSP chips [2]

Both the area per transistor and the energy per instruction have been shrinking roughly as the square of feature size. However, the power dissipation per unit area has been increasing, as illustrated in Figure 5.4, and may soon limit the simultaneous increase in speed and reduction in circuit size that has characterized microprocessors and DSP chips thus far.

The implications for the design of a WPSM system are that memory density and energy per instruction will continue to improve and hence sophisticated algorithms utilizing large stored databases will be feasible. However, for conduction-cooled environmentally sealed computers, computational density may not improve substantially beyond the current generation of laptops due to power density considerations. One solution is to distribute the processing to the sensors, enabling a higher degree of parallelism, and therefore lower clock frequency, at each distributed processor.

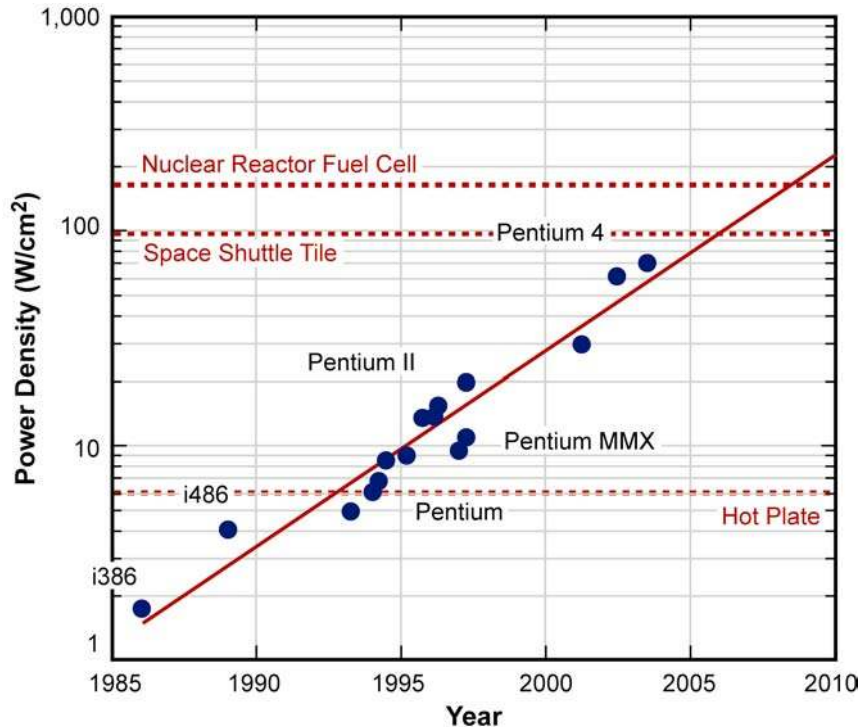

Figure 5.4 – Trend in power density for Intel microprocessors and comparison with the power density characteristic of other familiar systems. [2]

5.2. Processing Architectures

The two extremes of processing architecture are to centralize all of the data processing and analysis in a single computer or to distribute the processing at each sensor so that only high-level processed information is communicated from a sensor to the fusion processor.

5.2.1. Centralized Processor Architecture

In a centralized processing architecture, the sensor data is delivered to a centralized processor in unprocessed (raw) form. The raw data can be transmitted to the central processor in analog form, with analog-to-digital conversion occurring at the central processor, or the data can be digitized at the sensor and transmitted to the central processor in digital form. Analog transmission of the data requires a wired or wireless connection directly from each sensor to the central processor. Analog transmission of data is also subject to degradation from noise and may require amplification of the signal prior to transmission. For reasons of both scalability and fidelity, digitization of the data at the sensor is therefore preferred. The one disadvantage of digitizing data at the sensors is that precise time synchronization of the sampling across sensors may be difficult or costly. Therefore, it is important to establish the time precision needed to properly interpret and correlate the various physiological signals that will be measured.

One of the virtues of a centralized processing architecture is that raw data from all of the sensors is available for use in correlation and fusion algorithms. In terms of performance, centralized processing of the raw data affords the best opportunity for optimally extracting information from the jointly sensed data. However, for many applications of interest, optimal information extraction is not necessary and may be undesirable due to the required communication bandwidth and computational complexity associated with central fusion of the data. Improvements in processor and memory efficiency will permit more of the

computational complexity to reside in a single computer, but at present, programmable wearable computers, such as the system incorporated in Land Warrior, impose significant limitations on algorithm complexity and data/program storage.

Despite the drawbacks mentioned above, in the near-term development phase of a WPSM system, centralized processing is advisable since it provides the greatest flexibility for algorithm development and minimizes the complexity of coordination among sensors. As the understanding and implementation of various sensing modes matures, advantages may be gained by distributing some or all of the sensor processing to the sensors.

5.3. Distributed Processor Architecture

In a distributed processing architecture, the capability to digitize and process data is incorporated into some or all of the sensors. There are several motivations for implementing a distributed processing architecture:

- Processing data at the sensor can reduce the amount of information that must be communicated to the central processor, thereby reducing the required communication bandwidth and energy consumption.
- Sensor data can be processed, reduced, and stored at the sensor to enable radio silence without loss of data. This may also be important if the WPAN has limited bandwidth capability, since information can be buffered at the sensor.
- Processing at the sensor makes incremental upgrades and field upgrades of a system easier. Changes in the sensor and the subsequent data processing can be tested and implemented in the sensor module so that the output formats are unchanged and the upgraded or new sensor capability can be plugged into the PAN or WPAN with minimal or no modification of central processing software.
- Certain sensing functions can be turned on or off by removing power at the sensor and the associated processing and storage requirements will be disabled, conserving additional power.

The principal disadvantage of distributed processing is that the integrated sensor and associated processing module must be small enough to allow placement at the sensor site. This implies high NRE cost to design and implement compact packaging. Package constraints, in turn, limit the computing and memory resources that can be incorporated into an integrated sensor and processing module. Consequently, distributed processing should not be introduced into the early stages of the development processing unless it is essential to the realization of a particular sensing function or is already a mature sensing mode.

5.4. References

- [1] R. Kurzweil, *The Age of Spiritual Machines: When Computers Exceed Human Intelligence*, Viking Press, New York, 1998.
- [2] M. A. Richards, G. A. Shaw, "Chips, Architectures and Algorithms: Reflections on the Exponential Growth of Digital Signal Processing Capability," to appear *IEEE Signal Processing Magazine*.

Data Exploitation and Information Products

6.1. Physiological Constants and Health Information

In order to fully exploit the information available from the sensors described in Chapter 4, there are a number of physiological “constants,” unique to each individual, which must be supplied. For example, if a peripheral pulse transit time algorithm is used to estimate blood pressure by measuring the velocity of compression waves in the blood, the distance between the subject’s heart and the point on the arm where the compression wave is measured must be known. Similarly, body weight and body-mass index are important parameters in thermal prediction models. A system that requires these parameters to be manually entered by the user would be both unreliable and unappreciated by the user.

Therefore, the WPSM system must be capable of reading this information directly from an electronic “dog tag” issued to each user. Physically inserting or swiping a memory card in or near the computer could be used as the means of reading the information. Alternately, the information could be read over the wireless PAN that links the WPSM sensors together. However, requiring the information to be physically inserted or swiped provides a method for authenticating the user at the time of initialization. Specifically, a fingerprint sensor could be incorporated to enable the memory card. Unless the fingerprint matched the biometric information stored in the card, the transfer of medical initialization parameters would not occur.

6.2. ECG

A two-electrode ECG sampled at several hundred hertz provides a Q-R-S complex that can be analyzed to determine heart rate. Motion of the subject introduces electrical artifacts both from electrode movement and from the millivolt-level myoelectric signals associated with muscle movement. To the degree that motion artifacts momentarily corrupt the ECG trace, the algorithm for determining heart rate must be able to detect and ignore these artifacts, coasting through them by maintaining a moving average heart rate. The algorithm must utilize inputs from other sensors to predict the context of the current ECG measurement. For example, is the individual at rest or moving, what is the respiration rate, are the arm and leg movements consistent with walking or running, etc.? If the aggregate sensor data suggests an individual is running or walking briskly and the respiration is regular and deep, but the ECG signal is erratic, motion artifacts, intermittent electrode contact, or a sensor fault must be suspected.

In clinical and laboratory environments, every effort is made to eliminate motion artifacts through the use of multiple adhesive electrodes and control of patient motion. For the WPSM application, collection and analysis of field data under a variety of conditions is necessary to understand the performance limitations of any class of sensor and to understand how the variety of heterogeneous sensor inputs can be exploited to reduce the likelihood of accepting an invalid ECG trace.

The ECG trace will normally be used to derive heart rate, and heart rate will be analyzed to provide inputs to thermal models and to provide a control against other false reporting from other sensor modes. For example, if the respiration sensor indicates apnea but the heart rate remains normal, the respiration sensor may be suspect.

In general, the ECG and heart rate information will not be exported but will simply be analyzed, folded into algorithms for estimating physiological condition (green, yellow, red) and archived for possible future retrieval by a medic or unit commander. The amount of available memory and the mission profile will determine how long archived data is retained. In the case of a training exercise, anomalous data might be retained in memory for the duration of the exercise so it can later be analyzed. Analysis may lead to discovery of an error or fault in the physiological monitoring system, or it may indicate a previously undiagnosed physiological abnormality in the individual.

6.3. Respiration

A substantial amount of both metabolic and pulmonary information is contained in the rate, depth, and phasing of the abdominal and thoracic respiratory movements. Over most of the range of metabolic demand, the “minute rate” of ventilation (the product of rate and depth) should scale accordingly. Any deviation from this ratio would result in either respiratory alkalosis (minute rate too high) or acidosis (minute rate too low). In combat situations, hyperventilation may occur, and thus some degree of respiratory alkalosis is expected. If the minute rate were to fall below that soldier’s normal resting value during a combat maneuver, the most likely cause would be an injury of some type. Alternately, ischemia brought on by severe blood loss would lead to metabolic acidosis, resulting in rapid, shallow breaths. Although this is a normal compensatory response to acidosis, it might be confused with the typical level of anxiety and arousal present during battle.

Normal breathing involves a combination of both thoracic and abdominal (diaphragmatic) movements. During inhalation, both the thoracic and abdominal cavities simultaneously expand in volume, and thus in girth as well. If there is a blockage in the trachea or nasopharynx, the phasing of these movements will shift in relation to the degree of the obstruction. In the case of a total obstruction, the strong chest muscles force the thorax to expand, pulling the diaphragm upward in what is referred to as “paradoxical” breathing – paradoxical in that the normal phases of thoracic and abdominal motion are reversed. There are few reasons for a soldier to engage in continued sucking or self-stifled inhalation during combat. Thus, any signs of paradoxical breathing lasting for more than a few breath cycles suggests a serious respiratory problem.

6.4. Life Sign Detection

For a mortally wounded individual, defining the exact point of death is a complex medical and legal undertaking. Remotely assessing the life sign status of an individual is further complicated by the need to rely on sensors rather than direct contact and by the possibility that one or more sensors may malfunction as a consequence of the trauma associated with the wounding event. In order to arrive at a reliable assessment of life sign status, several different sensing modalities must be employed along with a means of confirming the operational integrity of the sensors. Given the maturity of current sensors, a decision tree for making a life sign assessment in the FY05 time frame is envisioned. The following strawman serves as an example:

1. Has the victim suffered a ballistic impact?
 - a. Check acoustic thoracic sensors and estimate location
 - b. Check bleeding sensors or blood pressure sensor

2. Is the victim breathing?
 - a. If no respiration signal, perform integrity check of plethysmography sensor
 - b. Check throat microphone for sounds of breathing
 - c. Check the time tag of last recorded respiratory cycle and playback throat microphone data.
3. Is the victim moving?
 - a. Check activity sensors (wrist and foot movement)
 - b. Check GPS location averaged over time for a trend
4. Does the victim have a heartbeat?
 - a. If no heart-rate signal, perform integrity check of ECG sensors
 - b. If heart beat, determine rate and derivative

A problem with such decision tree logic is that it presumes that all of the relevant contexts can be anticipated and accounted for in the decision tree. Note, however, that in flowing down this decision tree, there are a number of pathological conditions in which a warfighter might incorrectly be classified as alive for some period of time after death occurs. For example, a warfighter killed on a moving vehicle might be misclassified as alive since he may show apparent signs of erratic breathing due to vibration coupled into the chest cavity, and would appear to be moving translationally, and could have a detectable heart beat for some time after the onset of death. However, with the algorithm outlined above, each check point in the decision tree accumulates further evidence of death and provides a mechanism for assigning a cumulative confidence measure to the final assessment. With this algorithm, or a similar decision tree approach that accumulates evidence, there is little chance that a live warfighter would be incorrectly classified as dead.

Note that as sensor technology matures, additional sensors can be added to the life signs decision tree. For example, cortical oximetry could be introduced to assess perfusion to the cortical region of the brain. Note also that adding more sensors does not necessarily improve reliability of the assessment. A key criterion in selecting the suite of sensors used for the life sign assessment is to choose sensors that have uncorrelated false-alarm mechanisms and therefore provide non-redundant (i.e., orthogonal) information. An optimal selection of sensors can only be made if there is sufficient field data to characterize the failure modes and false-alarm mechanisms of the various sensors. Laboratory experimentation coupled with early and frequent collection and analysis of field data is an essential step in moving from design concepts with uncertain optimization to a quantifiable cost function for performance optimization.

6.5. Thermal Modeling

A significant body of work has been performed on the development of models and simulations to predict the temporal history of physiological parameters under varied conditions. The primary objective of the warfighter modeling and simulation task is to develop a reliable software system that extrapolates from the current physiological state of the soldier, the current and expected environmental conditions, and the operational conditions to predict the physiological limits of operation of the individual soldier. The predictive ability of such a model / simulation utilizing the currently sensed state of the soldier is a critical, required capability of a WPSM system.

There currently exists a well-developed, validated computer simulation that estimates critical physiological parameters based on physical, environmental, and operational conditions, namely SCENARIO [1]. SCENARIO has evolved from the fundamental, multiple-node model developed by Stolwijk and Hardy in the early 1970's [2].

The basis of the model is the thermal balance among a set of five concentric annular compartments (core, muscle, fat, vascular skin, and avascular skin) which generically represent the human body interconnected by a central blood compartment. Each compartment is characterized with a mass, volume and surface area, heat capacity, and blood flow. A set of six coupled, dynamic heat balance equations for each compartment is developed, relating the compartment temperature to physiological (sweat rate, heart rate, heart stroke volume, cardiac output, and state of hydration), environmental (environmental temperature and humidity), and operational parameters (heat production, clothing, etc.). The solution of the six equations provides the thermal history of each compartment.

The utility of this particular model in the context of warfighter physiological status monitoring is the link between the sensing capability and the predictive nature of the model. The sensors provide the current state of the soldier as characterized by heart rate, respiration rate, core temperature, hydration, and skin temperature. In addition, external sensors provide a measure of the current environmental conditions and activity level, while the individual soldier database provides personal data such as size, weight, body mass index, aerobic fitness, etc. The model can be executed on a regular basis (for example, once per minute) using the organic WPSM computing capability to determine the point at which the operational capability of the individual soldier is compromised.

The key to the use of a predictive model is the integration of the real-time physiological and environmental sensors with the model. This requires some modifications in the implementation, though not the content, of the current software simulation. It is currently implemented for analysis in a PC environment, not a real-time mode as envisioned here. However, there is no technical reason why the software cannot be modified for such a purpose. The key technical requirement for the modeling effort is the real-time integration of the sensor output with software simulation within the constraints of the WPSM computer.

A second key technical development with regard to the software mode is the development and implementation of the soldier-specific database. The model requires certain physiological attributes that are unique to each soldier. These attributes must be measured and archived in the soldier's interrogable electronic "dog tag." As the parameters change with age and fitness, they must be periodically monitored and updated to support autonomous, real-time physiological status predictions in a field environment.

6.6. Data Exploitation and Information Fusion Architecture

The fusion of information from multiple sensors by means of appropriately designed and calibrated algorithms establishes the framework for the desired functionality of a WPSM system. Figure 6.1 illustrates the data exploitation and information fusion architecture for a near-term system. Over time, the sensors shown in Figure 6.1 may be enhanced and new sensors may be added creating new opportunities for feature extraction and information fusion. Not shown in Figure 6.1, but essential to reliable operation, is a means for built-in test and calibration of the sensors. The built-in test should provide an indication of sensor reliability, and thus provide a means of vetting unreliable data from the feature extraction, fusion, and decision process. For many of the desired information products, environmental or microclimate sensor data is as important as the physiological sensor data.

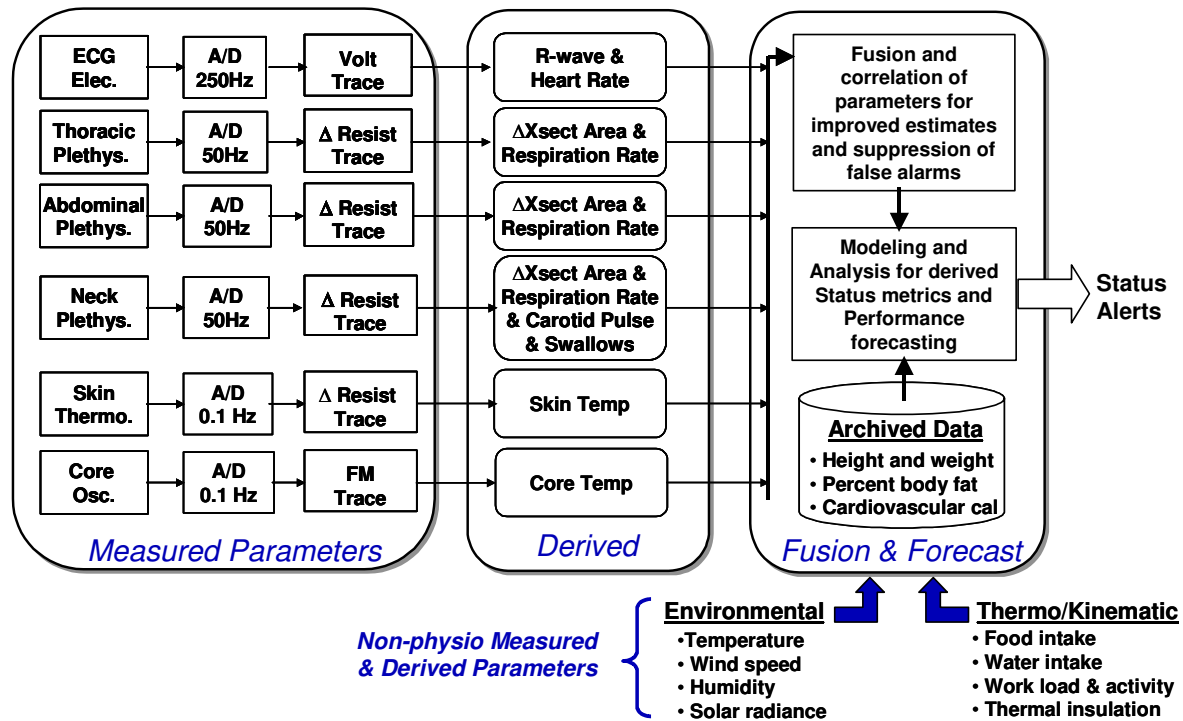

Figure 6.1 – Data exploitation and information product generation architecture

6.7. References

- [1] K. K. Kraning, R. R. Gonzalez, "A mechanistic computer simulation of human work in heat that accounts for physical and physiologic effects of clothing, aerobic fitness, and progressive dehydration," *J. Therm. Biol.* 22(4/5), 1997, pp. 331-342.
- [2] Chapter 4 in *Handbook of Physiology* – "Reactions to Environmental Agents" – provides in-depth discussion of the original model.

the key considerations in selecting a PAN technology are at the lower levels and include:

1. The physical interface
2. The data link control
3. The network transfer medium

The IEEE PAN standards 802.11 and 802.15 also focus on these three lowest levels of the protocol, with 802.15.4 specifically targeting low-bandwidth, short-range PAN applications.

In the context of the physiological status monitoring application, the most important design trades to be made in selecting a PAN are the propagation medium and the physical interface. These two elements have the greatest impact on the overall system performance metrics of weight, reliability, covertness, cost, and flexibility.

The design trade space decomposes into two major classes, wired networks and wireless networks. Within each class, there are a variety of options, and a system design may employ a combination of both wired and wireless links to form the complete network. Each of these classes is discussed in detail in the following sections.

7.3. Wired Networks

Wired PANs have the following advantages over wireless PANs (WPANs):

1. Simple, low-cost interface (e.g., a connector) between devices and the network
2. Low material cost
3. High achievable bandwidths
4. Limited RF emissions (low EMI signature)
5. Lowest power requirements when properly designed

For the physiological monitoring task, most, if not all, of the devices requiring network support will be located on the soldier and one might conclude that a wired network would be preferred since there is no requirement for mobility of the network devices once they are connected to the network. In addition, the high labor cost usually associated with installing a wired local area network (LAN) can be minimized by embedding wires in clothing and load-bearing harnesses and equipment at the time of manufacture. However, wires with conventional connection technologies have the following deficiencies when used for a PAN:

1. Wire lengths have to be adjustable to fit different size users
2. Wires are susceptible to snagging and to physical damage
3. Wires couple movement into connectors producing stress, leading to failures or intermittent connections
4. For sensors that need to be close to the body, layers of clothing present routing problems for wires when interconnecting sensors with processors and network components that may be worn over the outer layers of clothing
5. In the event of a ballistic wound, wires may be damaged either by the initial impact or by the process of cutting through clothing to expose a wound for treatment
6. Wires may add significant weight to the system depending upon the required gauge and the casing (insulation) required

The first two issues, adjusting wire lengths and the snagging of wires, can be addressed in recently developed electronic textiles by embedding wires in the textiles at the time of manufacture. Electronic textiles weave or sandwich conductors into clothing and thus conductor lengths can be automatically tailored to the size of the individual. For wires embedded in clothing, there is no problem with loose wires snagging or tangling. The problems of reliable connections and penetration through clothing still exist, but may be solvable through novel connector technology. For example, Velcro-like electrical connectors that are tolerant of gross alignment errors and have distributed contacts with no single point of failure may allow signals and power to be transmitted through layers of clothing while providing low-profile, flexible connectors that do not impede motion.

7.3.1. Electrical Conductors

In static LANs such as are commonly encountered in an office, network devices are powered from wall outlets. However, for networks comprising mobile devices, and in particular for a PAN comprising body-worn sensors, unless batteries are included in every network device, electrical conductors will be necessary to distribute power to the sensors, computers, and displays that comprise the network. Electrical conductors can be conventional insulated wires, flexible ribbon cable, or, in some cases, conductive fabrics.

7.3.2. Electrical Connectors

Anyone who has owned a pair of stereo headphones knows that the point at which the wires enter the headphones is the most likely part of the system to fail. The flexure, or strain, of the wire near the rigid connector eventually leads to metal fatigue and subsequent breakage. Most light-gauge insulated conductors therefore have semi-rigid rubber reinforcement to serve as a strain relief near the connectors in recognition of this reliability issue. Other solutions to this problem include fabricating laminated conductors in flat ribbon form (ribbon cable) or coiling a ribbon conductor around a flexible strength member to distribute the strain during flexure (tinsel wire).

A second problem with electrical connectors for PAN use is susceptibility to corrosion and intermittent contact due to wear, dirt, and moisture. Conventional mil-spec electronic systems usually have formidable connectors in an attempt to seal out dirt, moisture, and other foreign substances. This approach is incompatible with the comfort, cost, and weight goals for a wearable PAN for warfighter physiologic and environmental modeling.

Alternatives to conventional connector technologies are clearly needed. One possible approach is to employ conductive Velcro, as seen in Figure 7.2, or a suitable variant. Conductive Velcro was developed primarily to provide anti-static wrist straps for technicians handling electrostatically sensitive parts. Conductive Velcro comes in two forms. In one form, the hooks and loops are themselves made of a conductive carbon fiber-filled polymer. In the second case, silver is deposited onto conventional nylon hook-and-loop Velcro material. The carbon Velcro can become messy as hooks and loops disintegrate with use.



Figure 7.2 – Conductive Velcro

One of the considerations in developing connectors with conductive Velcro is the fact that the resistivity of the connection varies with the degree of pressure applied to connection. Typical resistance between a male and female Velcro strip under pressure is 1–2 ohms.

Another issue specific to the metallized nylon material is electrolytic corrosion. Modulating the power so there is no net DC potential between any exposed conductors and capacitively coupling the signals can prevent electrolytic corrosion. The AC power would then need to be rectified and regulated within the electronics at the receiving end. Signal lines could be similarly modulated using standard differential bi-phase data coding formats.

Finally, reliability and longevity are important issues that are difficult to achieve with this technology, particularly in the harsh environments associated with field deployment for combat units.

7.3.3. Optical conductors

Fiber optic conductors are useful for transmitting digital signals. In principle, fiber could be used to deliver power to devices as well. However, the power densities achievable, and the complexity and efficiency of the devices for converting optical power to DC power to drive sensors and electronics render the use of fiber for power delivery impractical.

An important application for fiber conductors is in connection with the high-impedance Photrodes developed for non-contact ECG measurements. These photoelectrodes require a reference CW laser source supplied over optical fiber [3].

7.3.4. Conductive fabric

Conductive fabrics are available from a variety of sources and include polyester woven, non-woven and mesh fabric with copper and nickel, and copper and nickel-plated. These have generally been developed with lightweight fabric and special finished coating to meet various EMI/RFI shielding requirements. The conductive fabrics generally exhibit excellent electric conductivity and good abrasion resistance.

7.4. Wireless Networks

Wireless communications, and in particular wireless networks, have grown in popularity primarily because they enhance mobility, and significantly reduce (labor) cost of network installation relative to wired networks. Five classes of free-space propagation phenomenology for wireless networking are described below and assessed for suitability to the physiological status monitoring application.

7.4.1. RF

RF is the predominant propagation mechanism employed in wireless networking. In the summer of 2000, the FCC allocated 14 MHz for wireless medical telemetry service (WTMS). The allocation is split across three bands from 608–614 MHz, 1395–1400 MHz, and 1429–1432 MHz. This allocation replaces the former use of UHF and VHF bands, primarily because the UHF and VHF bands are needed for digital television and private, land mobile radio use. This reallocation of bandwidth means that existing systems such as the Nexan Clear Path described in Section 3.3 must migrate to a different radio technology. However, there are a variety of RF networking technologies available that could be employed in the WTMS bands or a higher-frequency band. For the purpose of implementing a near-term capability, IEEE 802.11b and Bluetooth are the two most obvious candidates. Employing widely used commercial RF protocols is attractive from the perspective of reducing cost. However, as discussed in the following sections, there are significant drawbacks to employing commercial RF links in a battlefield environment.

Bluetooth has recently been annexed into the IEEE 802.xx family of networking standards as 802.15.1. There are four wireless PAN standards under the 802.15 umbrella as indicated in Table 7.1, all based on the 2.4GHz unlicensed ISM band.

Table 7.1 – IEEE 802.15 Working Groups

IEEE Standard	Objective
802.15.1	Annexation of Bluetooth, 720 kbps, 10m range
802.15.2	Standards for coexistence in 2.4GHz ISM band
802.15.3	High data rate (11–55 Mbps), 10–70 m
802.15.4	Low data rate <250 kbps, ranges < 10 m

Of the four standards referenced in Table 7.1, IEEE 802.15.4 is the most closely aligned with the needs of a WPSM PAN. Although the standard is undergoing balloting and not publicly accessible, the likely attributes of the standard are listed in Table 7.2.

Table 7.2 – IEEE 802.15.4 Preliminary Specifications

Property	Range
Raw data rate	31–250 kb/s
Range	Typical 10 cm to 10 m or up to 100 m with trade-offs
Battery life	Application-dependent, operate w/o battery (power scavenging)
Latency	10–50 ms; or less than 1 sec
Location awareness	Optional
Nodes per network	Up to 65,534 (exact number to be determined)
Topology	Star and mesh are desired
Complexity	Lower than current standards
Types of traffic	Asynchronous; option to support synchronous
Desired frequency	2.4 GHz unlicensed and international band
Temperature	Industrial temperature range –40 to 85°C

An emerging technology, which has only recently been certified by the FCC for short range applications, is ultra-wide band (UWB) RF. Using narrow pulses, typically <1 ns, UWB spreads RF energy over a spectrum of several GHz as shown in Figure 7.3. Modulation techniques include pulse-position, binary phase-shift keying and others with maximum pulse repetition frequencies anywhere from hundreds of thousands to billions of pulses per second. FCC Part 15 limits on UWB are equivalent to –41.25 dBm/MHz. In comparison, 2.4GHz ISM band emissions, where Bluetooth and 802.11b operate, are 40+ dB/MHz higher.

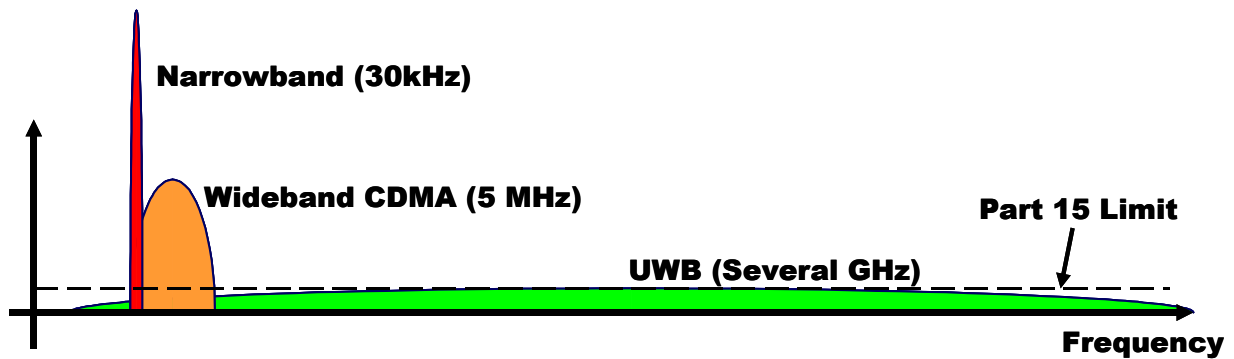

Figure 7.3 – UWB frequency occupancy spans existing licensed bands and so must conform to FCC power limits (after Leeper [4])

The principal motivation for commercial interest in UWB is the possibility of high bandwidth waveforms coexisting with licensed bands. Additional motivation includes the potential for handling multipath by aligning and adding delayed pulses (Rake receiver) and the potential for low transceiver power because of the baseband modulation. Low transceiver power, rather than high bandwidth, is of potential interest for a WPSM PAN. However, UWB is particularly susceptible to narrowband interference sources, which would include intentional jamming, and the digital signal processing requirements are beyond current DSP technology. XtremeSpectrum announced the first commercial UWB chip set, dubbed *Trinity*, on 24 June 2002 [2]. The three-chip set conforms to IEEE 802.15.3 MAC standard, and a fourth chip is available to interface to a host processor.

IEEE 802.11 is a wireless Ethernet standard employing TCP/IP protocols. IEEE 802.11 RF networking variants include 802.11b, an 11Mbps standard operating at 2.4GHz, and 802.11a, a 54Mbps standard operating at 5.1 GHz. A third variant, 802.11g, provides 54Mbps bandwidth over a 2.4GHz carrier.

The Bluetooth standard also operates at 2.4 GHz and was originally conceived as a wireless replacement for cables, with the goal of mass-producing transceivers for a cost of \$5–10 per device. The operational range for Bluetooth is nominally 10 m, and currently available implementations sell for closer to \$100 than \$10. An example of a commercial Bluetooth transceiver module is shown in Figure 7.4. The Bluetooth protocol includes the provision for forming piconets, with one master and seven slave units.

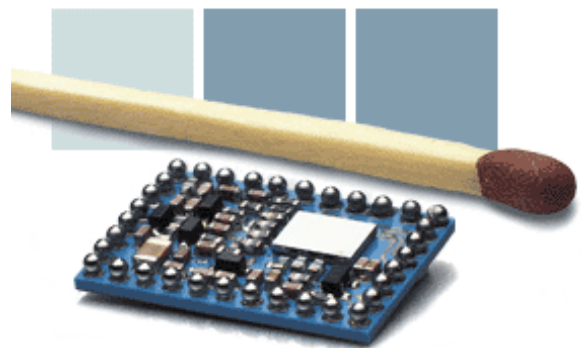

Figure 7.4 – Bluetooth transceiver module

Despite the ubiquitous presence of RF and the large commercial investment in low-power wireless, there are drawbacks to employing RF for a WPSM PAN. Some of the potential drawbacks associated with an RF PAN include

- Relatively high ratio of electronic power dissipation to transmit power for short-range links (factor of 100x or more)
- Susceptibility to mutual interference when many systems are collocated

- Susceptibility to enemy interception, direction finding and jamming
- Body blockage (loss seen by devices on opposite sides of body)

Among 802.11, Bluetooth, and UWB, only 802.11 is a full network protocol. A comparison of representative implementations of the 802.11a standard and Bluetooth is provided in Table 7.3

Table 7.3 – Comparison of Representative Implementations of RF and Magnetic Induction Systems

Parameter	802.11a	Bluetooth	UWB [†]	Induction
Frequency band (GHz)	2.4–2.4835	2.4–2.4835	3.1–10	.01356
Tx power (mW)	30	1	1	25
Nominal transceiver power (mW)	1425	80	200	12.5
Data rate (Mbps)	11	0.725	25-100	0.205
Nominal Energy/bit (nJ/bit)	130	100	8-2	60
Modulation/demodulation	coherent	coherent	baseband	coherent
Nominal range (m)	150	10	10	1-2
Body blockage loss	high	high	high	negligible
Standoff detection range (km)	>100	>20	>20	<0.1

[†]UWB was approved for short-range (i.e., low-power) use 14 February 2002

7.4.2. Magnetic Induction

Magnetic induction is currently employed in variety of commercial systems for short-range wireless communication. As illustrated in Figure 7.5, the notion is to modulate a magnetic field and to measure the magnetic field modulations by means of a small coil. The standard modulation schemes used in RF communications—amplitude modulation, phase modulation, and frequency modulation—can be employed in a magnetic induction system. While the term “magnetic induction” distinguishes these systems from conventional far-field RF systems, Maxwell’s equations for time-varying electromagnetic fields imply that the time-modulated magnetic field will induce a time-varying electric field, and hence free-space magnetic induction systems for wireless communication can be modeled and understood simply as low-frequency RF systems that are designed to work in the near-field.

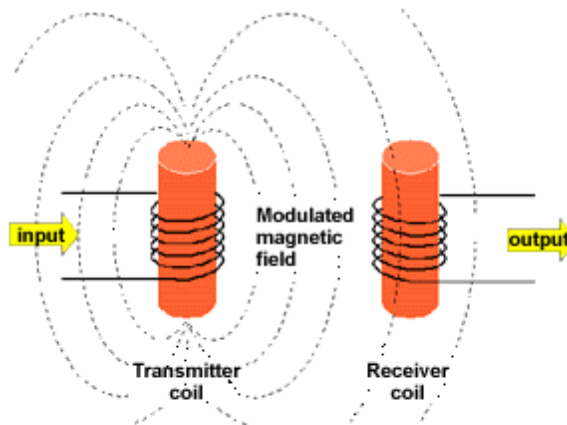

Figure 7.5 – Free-space magnetic induction concept for wireless communication

The virtue of this near-field approach, which is made possible by the low RF frequency, is that the near-field power level falls off as the sixth power of range. Consequently, interference between devices is negligible as separations increase beyond a meter or two. Furthermore, the fact that magnetic induction systems operate at low frequencies has two important benefits. First, lower frequency operation means that transceiver power dissipation can be lower since the power dissipation in CMOS is proportional to the frequency of operation. Second, operation at low frequencies confounds

attempts at standoff detection and direction finding because environmental noise is high and directional antennas require extremely large apertures.

In the commercial world, near-field magnetic induction technology is applied primarily to RF tagging or identification, hereafter termed RFID. The low-frequency, near-field operation of magnetic induction technologies appears to also offer distinct advantages over far-field RF for the physiological status monitoring. For this reason, a detailed description of principles of operation is included along with an analysis of a commercial device that employs the technology to implement a wireless analog voice link.

7.4.2.1. Operational Concepts and Performance

Since free-space magnetic induction systems are designed to work in the near-field, the far-field power density of these systems is much lower than one would encounter for an RF system designed to work in the far field. This is illustrated in Figure 7.6, which shows the magnetic field strength falling off at 60 dB per decade in the near field. Depending upon the specific design, transition to far-field performance occurs somewhere in the 1–10m range, at which point the propagating energy from the free-space magnetic system conforms to the same propagation rules as any far-field system.

To illustrate the advantage of operation in the near-field, note that the Liberty-Link magnetic induction transceiver developed by AuraComm has a measured field strength of 11.4 dB μ V/m at a range of 30 m¹.

For a plane wave propagating in free space, this corresponds to a power density of -96 dBm/m². In comparison, a Bluetooth chip radiating the prescribed 1mW transmit power, produces a power density of -41 dBm/ m² at a range of 30 m. The power density of a Bluetooth-compliant PAN is therefore nearly one-third million times higher at a range of 30 m than that of a PAN based on free-space magnetic induction.

Figure 7.6 – Field strength versus range for magnetic induction system

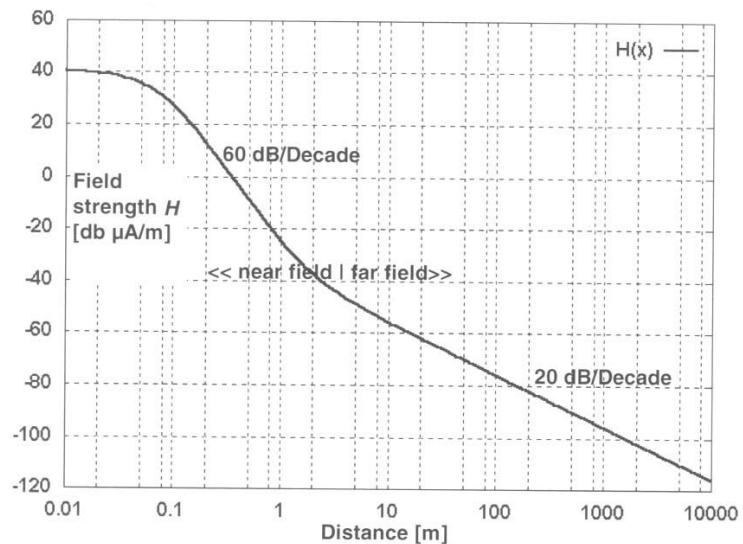

In order to compare the detectability of a 2.4GHz ISM-band RF PAN to a free-space magnetic PAN, a Bluetooth transceiver operating at 1mW EIRP is compared to the Auracomm VoiceLink and LibertyLink transceivers operating at 1.76 MHz and 13.56 MHz respectively. The E-field measurements at 30m range for the Auracomm transceivers are converted to an equivalent transmit EIRP, assuming an R² propagation loss.

¹ The FCC requirement for unlicensed short-range devices in the 10-15 MHz band requires that the E-field strength not exceed 29.5dB μ V/m at a range of 30m.

Figure 7.7 shows the detectability of the systems, assuming the ELINT receiver has a 0.1m² aperture.

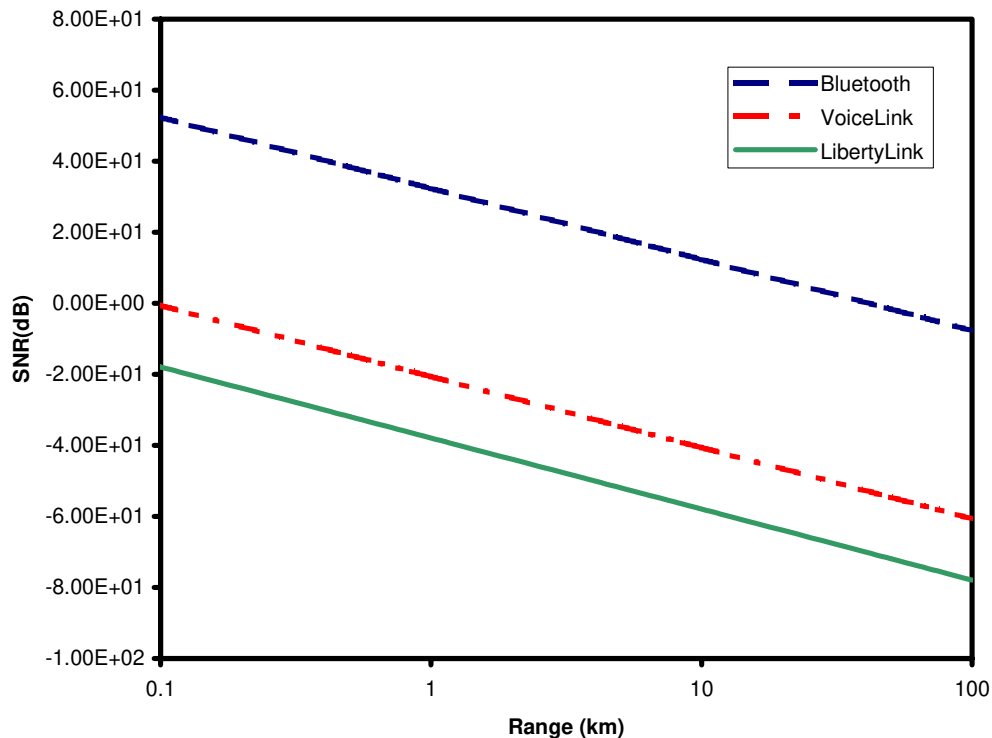

Figure 7.7 – Standoff detectability of three PAN technologies; 2.4GHz RF (e.g., Bluetooth), 1.76 MHz magnetic (e.g., VoiceLink), and 13.56MHz magnetic (e.g., LibertyLink)

Note that there are three important factors that affect the comparison of Figure 7.7. First, at 2.4 GHz, a 0.1m² aperture provides 20 dB of receive gain, boosting the SNR at the ELINT receiver. In comparison, the ~10,000x lower-frequencies of the free-space magnetic systems do not afford the opportunity for receive gain or direction finding through beam pointing, except with enormously large apertures on the order of 100 m or more, or the deployment of multiple time-synchronized receivers employing time difference of arrival to establish bearing and perhaps location of an emitter. Second, the sky noise dominates the SNR of the low frequency systems. Lighting and other sources of noise effectively obscure weak signals at these low frequencies. Third, Bluetooth is radiating enough power to support a 10m communication range. Since a PAN only requires a 2m range, one might consider reducing the power of the Bluetooth transmitter by the square or even the fourth power of the desire range reduction, i.e., by a factor of $(10/2)^2 = 25$ or even $(10/2)^4 = 625$, but this would still not make up for the difference in measured far-field power between the low-power Bluetooth and a near-field magnetic induction system. Furthermore, one reason the Bluetooth specification requires a 1mW transmitter for only a 10m range is to overcome the effects of RF interference in the environment and line-of-sight blockage. The reliability of a 10μW or even a 100μW Bluetooth PAN in the presence of body blockage and other RF interferers may not be acceptable.

As indicated in Figure 7.7, the far-field signal of the near-field magnetic induction systems is well below noise at ranges of 100 m or more, whereas the signal from a 2.4GHz RF system is detectable at ranges of 50 km or more with a modest receive aperture.

7.4.2.2. Commercial Standards and Systems

There are a variety of free-space magnetic induction communication systems in production commercially. The majority of the systems are oriented toward RFID at very short ranges. Frequently, the systems are built around small nonvolatile memories and are employed to tag or identify products to enable non-contact interrogation by a scanner. The commercial devices are covered by a variety of standards depending upon the specific application and country of operation [1]. A detailed theoretical analysis and experimental verification of a near-field magnetic induction wireless headset is presented in Appendix A.

In terms of the WPAN application, three commercial chip developments are of interest. Auracomm produces an eight-channel near-field magnetic induction communication chip that provides wireless analog voice link with 6kHz bandwidth. A commercial wireless headset employing the Auracomm VoiceLink chip is used as the basis for the analysis in Appendix A. Auracomm also has a second-generation chip under development that is designed to support 3 channels of digital data at 50 kbps per channel, plus a digitized speech channel for an aggregate bandwidth of 205 kbps. A block diagram of this LibertyLink digital data chip is shown in Figure 7.8. The Auracomm LibertyLink operates in the 13.56MHz band.

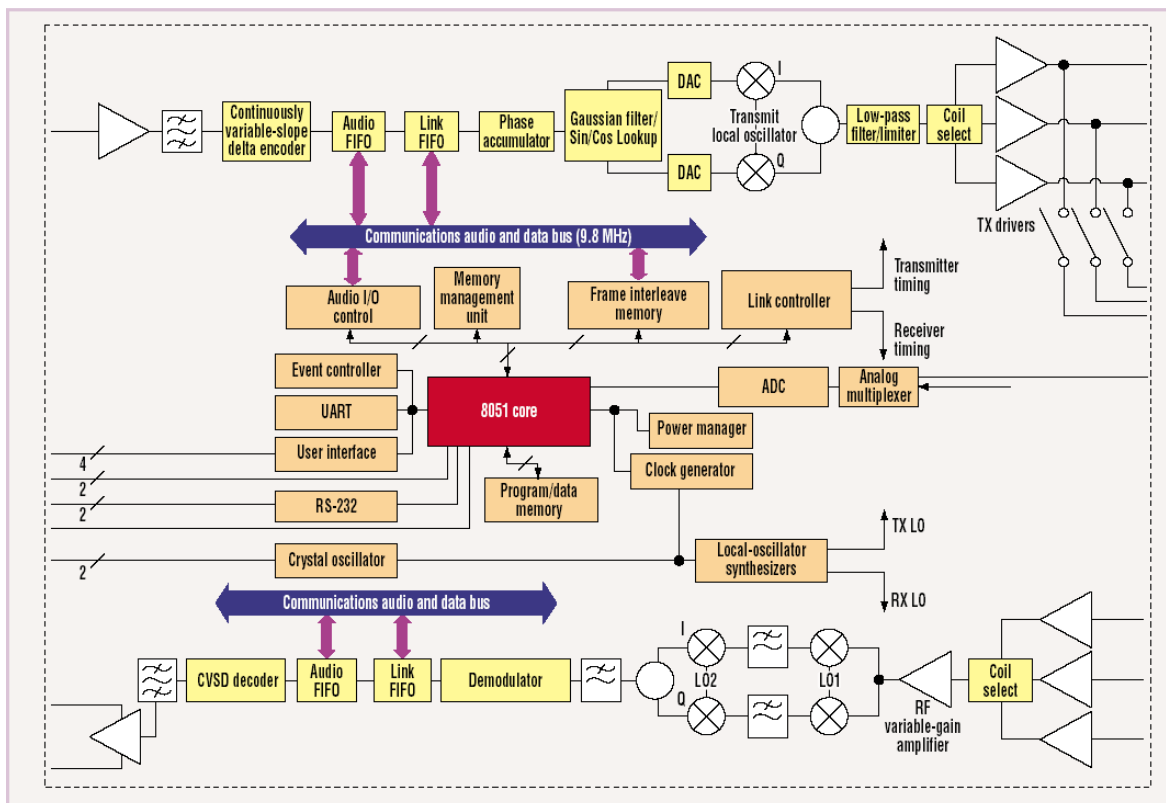

Figure 7.8 – Block diagram of Auracomm LibertyLinkTM communication chip

Xemics produces a transceiver chip and development module that operates in the 0–135kHz ISM band but only supports 1.82kbps data bandwidth. A photo of the Xemics XM1209 transceiver module is shown in Figure 7.9. The Xemic chip has a programmable output power with a nominal range of 1–3 m.



Figure 7.9 – Xemics XM1209 38kHz transceiver module

The operational characteristics of these three commercial chips—VoiceLink, LibertyLink, and Xemics 1209—are summarized in Table 7.4. All of the chips operate at a sufficiently low frequency that galactic noise and other sources of environmental noise will tend to mask their signal to anyone not in the near field of the antenna.

Table 7.4 – Performance of Three Commercial Near-Field Magnetic Induction Comm. Chips

Parameter	VoiceLink	LibertyLink	Xemics 1209
Frequency (kHz)	380–508; 1740–1789	1050–1450	36.86
Tx power (mW)	25	25	10 - 330
Transceiver power (mW)	30	12.5	5-330
Data rate (kbps)	analog	204.8	1.82
Energy-per-bit (nJ/bit)	470 ²	60	≥2750
Modulation	RC-AM ³	GMSK ⁴	CP-FSK ⁵
Nominal range (m)	1-2	1-2	1-3

7.4.3. IR

The two predominant protocols for IR communication are IrDA and IEEE 802.11. IrDA is a point-to-point line-of-sight (LOS) communication standard. The IEEE 802.11 is often discussed only as an RF networking standard, but it also includes specification for non-line-of-sight (NLOS) IR communication protocol. However, the IEEE 802.11 standard for IR communication presumes the devices will be used inside a building where reflections from walls and ceilings provide the mechanism for NLOS communication. Consequently, neither IrDA nor IEEE 802.11 is a suitable standard by itself for WPSM PAN needs since the PAN must work outside with sensors that are not always within LOS of the base station.

However, there are possible niche applications for IR communication within the PAN. For example, IR could serve as a bridge between clothing layers. In this application, an LED near-IR source and photodetector would serve as a very-short-range transmitter and receiver pair. Integrated arrays of vertical cavity surface emitting laser (VCSEL) sources with integrated photodetector arrays have been developed for high-speed digital networking. For those portions of the soldier’s combat uniform that are porous or that overlap at specific points, transceiver arrays could be embedded at designated locations in the clothing layers in order to provide communication links across the clothing layers. Power for the transceivers could be supplied from a central source through wires embedded in the clothing. The power required to complete a link through one or more layers of clothing will

² Effective energy-per-bit assuming 6kHz analog voicelink equivalent to 64kbps CVSD coding

³ Reduced Carrier Amplitude Modulation

⁴ Gaussian Minimum Shift Keying

⁵ Continuous Phase Frequency Shift Keying

depend upon the optical transparency of the fabric (looseness of the weave) and could be very small, given the short range of the link, essentially the thickness of the clothing layer.

Another niche application for an appropriately designed IR link is to provide wireless connectivity from a soldier computer to a head-up display. IrDA supports rates of up to 4 Mbps with near-term plans for 16 Mbps over a distance of 20 cm or less. A 640 x 480 pixel display running 24-bit color with a 30Hz frame rate requires a 221Mbps link, far more bandwidth than near-term IrDA transceivers can support. However, a head-up display utilizing compression techniques to represent low-resolution graphics and text could be designed to work with an IR link, thus eliminating the need for a cable between the soldier's body and helmet. For high-resolution graphics such as map displays, the head-up display would be augmented with a high-resolution graphic tablet that is embedded in the soldier's uniform, say on the forearm, or carried in a pouch. The concept is developed more fully in Chapter 8, *User Interface*.

IrDA comm. links are currently implemented in 300 million consumer products per year, with an estimated growth to 1.3 billion by 2004. The dominant consumer applications growth rates are mobile phones (70%), PDAs (52%), and PCs (25%). Analysis of the underlying IrDA Link Access Protocol (IrLAP) has shown that it is capable of supporting data transfer rates of up to 100 Mbps [6].

7.4.4. UV

Free-space optical PANs are predominately IR and designed for indoor use. However, ultraviolet (UV) sources are being investigated and developed for use in outdoor free-space LANs[10]. The mid-UV region of the spectrum has the feature that nearly all solar radiation is absorbed by the atmosphere before reaching the ground. Consequently, for a UV system operating outside, there is no problem with high backgrounds from solar illumination or blinding of detectors at particular sun angles. Furthermore, since atmospheric gases scatter UV radiation, NLOS communication is possible using the IR protocols devised for IEEE 802.11. A further advantage of either LOS or NLOS UV comm. is that it is inherently short range relative to RF propagation because of atmospheric absorption and scattering.

Therefore, UV communication represents a potential mechanism for covertly communicating information over a local area to many users from one user to another. Commercial chips designed to implement IR communication protocols can be readily adapted to UV communication. UV links could also be used to implement communication through layers of clothing as described in Section IR; however, one must be careful to shield exposed skin. Fortunately, plastic film is a good shield, and a thin layer of plastic film could provide adequate shielding of the skin, as well as shielding from close-range stand-off detection.

At present, low-cost semiconductor UV sources and detectors in the solar blind region are not commercially available, but the DARPA semiconductor UV optical source (SUVOS) program has demonstrated semiconductor sources at wavelengths below 280 nm. There are also efforts to develop semiconductor detectors in the solar blind region for missile warning. The maturation of these device technology programs could lead to cost-effective systems for short-range covert communications between multiple users.

7.4.5. Ultrasound

A new technology concept that was introduced in 2002 and reported at the *SPIE Aerosense* conference in 2003 involves digital communication at low ultrasonic frequencies, nominally 40 kHz [9]. The progenitor of the technology claims that ultrasonic transceivers can be

implemented with 2x lower power requirements than an RF system and represent an alternative to the use of RFID tags. Furthermore, experiments indicate that ultrasound travels well through the body and therefore could be used as the basis for a body-PAN. Propagation velocity in the body is variable from 300 to 3500 m/s, with the lower velocity establishing a maximum signaling latency of a fraction of a millisecond. Bandwidths in the kHz range may be feasible given the 40kHz carrier.

An issue with this technology is the lack of data on long-term health effects of ultrasound on the human body. Although ultrasound imaging is a commonly used medical diagnostic tool, animal experiments suggest there may be harmful biological effects from long-term exposure at the higher frequencies associated with ultrasonic imaging [7, 8]. We were unable to ascertain whether human health studies have been conducted at the frequency and power levels corresponding to the proposed ultrasound transceiver.

7.4.6. Technology Assessment

Based on the Technology Readiness Level (TRL) definitions provided in Appendix G, the components for an RF LAN (e.g., Bluetooth chip) are at TRL 7–8 since they are being used in commercial systems, but not under the conditions and constraints needed for WPSM. At the system level, RF PANs in the ISM band are being used successfully for ambulatory monitoring, for example the Nexan system, but once again, not in the configuration required for WPSM. Signature management and power consumption are two important shortcomings for existing RF PAN concepts, leading to an overall assessment of TRL 5–6 for an RF PAN.

For near-field magnetic induction systems, chip technology with sufficient bandwidth is only now emerging although there are many examples of lower bandwidth systems in commercial use. Therefore, component TRL is 5–6. At the system level, near-field magnetic induction offers lower power dissipation and better signature management than coherent RF systems. At the system level, commercial products exist but do not provide all of the features desired for a WPSM PAN. Therefore, a TRL 5–6 seems appropriate for the magnetic induction PAN as well as the RF PAN. However, with sufficient development, the magnetic induction PAN promises to be a better match to the WPSM PAN requirements than a coherent RF PAN.

IrDA technology for low-bandwidth (~ 4Mbps) LOS links is commercially available and could be adapted for use in body-helmet links although solar interference may inhibit link performance.

UV and ultrasound technologies are still in the R&D stage with a TRL range of 3–5.

7.5 Hybrid Networks

At present, commercial products such as wearable computers and ambulatory monitoring devices typically use wires to connect sensors, processors, and displays together on the body, and ISM-band or other unlicensed RF wireless links to transmit data off the body.

For the WPSM system, it is likely that wired connections will not be completely eliminated for some time. Once sensors and the associated sensor processing mature, it will be possible to make sensors and the associated wireless link sufficiently small and energy-efficient that they can be run on batteries, eliminating the need for wires. Until this occurs, the need to supply power to sensors and displays via a wire will lessen the value of wireless networking and perhaps slow adoption.

During the spiral development process for WPSM, it is likely that wired and wireless networks will coexist, with wireless employed for low-power mature sensor technologies and wired used where high-power or uncertainty regarding sensor function and data inhibit the introduction of battery operation with wireless data links.

7.6 References

- [1] <http://www.aimglobal.org/standards/rfidstds/RFIDStandard.htm>
- [2] <http://www.extremespectrum.com/>
- [3] S. A. Kingsley, et al., "Revolutionary Optical Sensor for Physiological Monitoring in the Battlefield," *SPIE Proceedings*, Vol 5403, 12–16 April 2004.
- [4] D. G. Leeper, "Wireless Data Blaster," *Scientific American*, May 2002, pp. 64–69.
- [5] S. Williams, "IrDA: Past, Present, and Future," *IEEE Personal Communications*, Vol. 7, No. 1, Feb 2000, pp. 11–19.
- [6] A. C. Boucouvalas and V. Vitsas, "100Mbps IrDA Protocol Performance Evaluation," *Wireless and Optical Communications IASTED Proceedings*, 27–29 June, 2001, pp. 49–57.
- [7] *Guidelines for the Safe Use of Ultrasound*, Ministry of Public Works and Government Services, Canada, 2001. (<http://www.hc-sc.gc.ca/hecs-sesc/ccrpb/safetycodes.htm>)
- [8] C. Johnson, "New Controversy Over Ultrasound Safety," *News in Science*, 15 June 1999. (http://www.abc.net.au/science/news/health/HealthRepublsh_28980.htm)
- [9] R. Forcier, "Wireless Digital Ultrasonic Sensors for Proximity ID, Access Control, Firearm Control and C³I in Homeland Security and Law Enforcement Applications," *SPIE Proceedings*, Vol 5090, 21–25 April 2003.
- [10] G. A. Shaw, A. M. Siegel, J. Model, M. Nischan, "Field Testing and Evaluation of a Solar-Blind UV Communication Link for Unattended Ground Sensors," *SPIE Proceedings*, Vol. 5417, 12–16 April 2004.

User Interface

Apart from the sensors, which are a form of input “user interface,” the user interface for control and query of a WPSM system consists of three components:

- Hardware to present (display) information to the user
- A menu from which to select system control and query functions
- One or more user input devices to initiate control and query actions

These user interface components will be adapted to the particular user. An infantry squad member will have a simpler and less informative interface than a medic or a platoon leader. The information and control functions available to the user are profiled for each user or class of user.

In the long term, the information will be routed and displayed through the LW/FFW computer. Since this computer will include a display and graphical user interface, the information presentation and user interface will most likely utilize whatever interface modes and mechanisms are available through the LW/FFW computer. During development, a separate user interface may be hosted on the WPSM computer.

8.1. Alerts

The information available to all levels of user includes certain classes of alert. At the soldier level, these alerts must be actionable and must be presented in such a manner that they do not interrupt ongoing activities or distract the user, thereby placing him in possible jeopardy. Examples of soldier alerts include

1. Detection of a hazardous substance
2. Dangerously low or high core-body temperature
3. Dangerously low foot or hand temperature
4. Dangerously low hydration state

These alerts may be haptic or audible depending on the situation, and the alerts may be augmented with information presented by means of a display, such as the Land Warrior head-up display. Some alerts may be maskable by the user, while others, such as a hazardous substance alert, may not be maskable.

8.2. Display Options

8.2.1. Hardware

In a deployed system, the WPSM functions and controls would be accessed through the LW head-up display system. For research and field testing, a separate display will be required.

Most computer display technology has been developed for indoor use and is difficult or impossible to use outdoors in full sunlight. Furthermore, the visible light from commercial displays would compromise both night vision and signature control of a nighttime mission. A PDA with a wireless interface to the WPSM computer would provide adequate resolution for initial field testing of a prototype system. If, as recommended in Section 1.10.1.10.2.3, commercial wearable computers are used during the development phase, back-illuminated touch screens as well as head-up displays are available. Figure 8.1 shows the Xybernaut MA-V wearable computer with associated head-up display.



Figure 8.1 – Xybernaut commercial wearable computer with head-up color display

8.2.2. Software

Which menus and information need to be provided to the user is a question that can only be answered after the baseline sensor suite is defined and the performance objectives for the derived physiological information are established. In a deployable system, a small number of haptic or through-the-headset audible alerts might be all that is provided to an individual squad member. However, at the squad-leader or platoon-leader level, aggregated information about physiological status might be required in order for the leader to monitor the health status and readiness of those under his command. Figure 8.2 is a mock-up of an information display showing a high level of physiological status information on each of the reporting Blue Force entities. This level of detail is inappropriate for a combat situation but

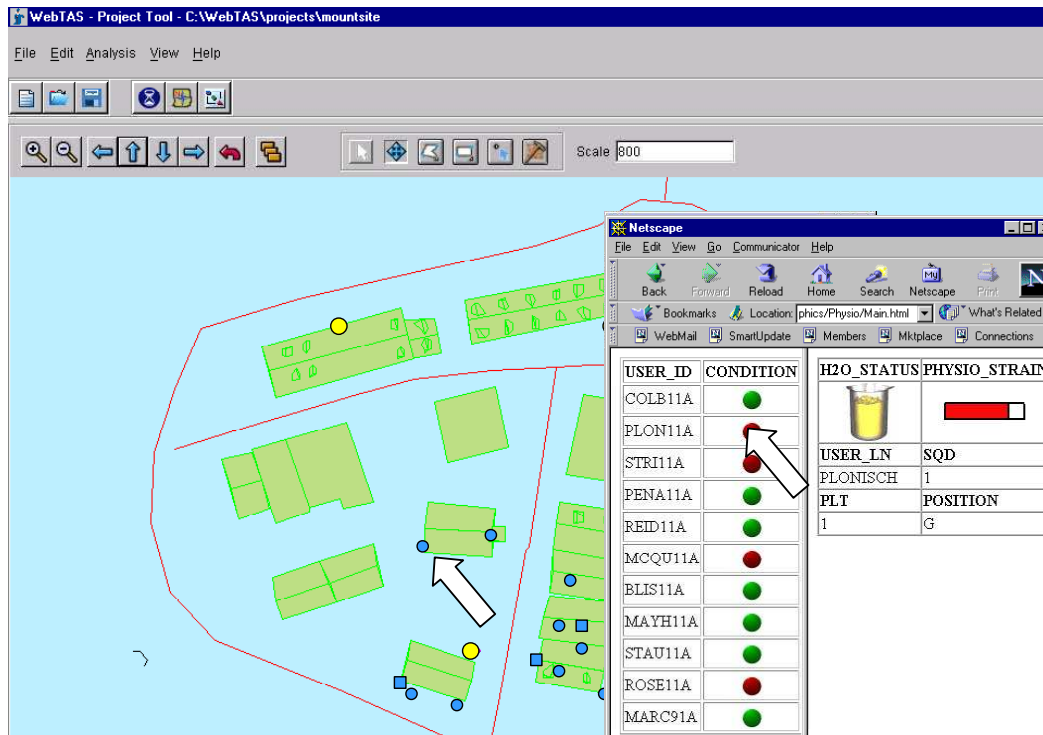

Figure 8.2 – Mock-up of physiological status display for a platoon leader or higher-level command

might be appropriate during training. At the lowest level, physiological status is indicated as green, yellow, or red. Leaders with the appropriate access authority can request additional information on specific individuals. This illustrates the concept of an information-on-demand system rather than a data push system. In general only the green, yellow, or red status information is communicated off-body for any individual. The additional data is not transmitted unless requested by an authorized user, thereby conserving bandwidth. However, an authorized user, such as a medic, would be able to request increasingly detailed levels of archived information down to the level of the raw data, such as an anomalous ECG.

The mock-up of Figure 8.2 also includes a display of geolocation information for the Blue Forces that are the under command of the particular user. This type of information would ultimately be displayed on the LW or FFW system in which it would be merged with other types of Blue Force tracking and status information. In an operational system, the information and display format would most likely be defined within the common-operating-picture (COP) format and display protocols.

8.3. Menu Functions

The format and look of menus will ultimately need to conform to LW/FFW standards. However, in terms of function, menus should provide simple means of controlling parameters and querying information without the need for keyboard entry. Menus will be used primarily during initialization or changing of system parameters and are more appropriate for R&D and field testing than for a deployed system. Nevertheless, there may be occasion, even in a combat environment, for menu interaction. Menu functions and options to consider include

- Alert settings – what alerts should be pushed and what are the preferred methods of annunciation: haptic, visual, or audible
- Wounding event – indicate the type of the wound (e.g., bullet, fragment, overpressure, laceration, chemical) and the location (e.g., leg, arm, torso, head, internal)
- Operational status – field test, training, covert, energy conserving

Some of these menu functions, for example, operational status, may ultimately be subsumed in, or inferred from, LW/FFW menus.

8.4. Input Devices

Ultimately, the WPSM menu options will be controlled through the LW computer interface. However, during early development and data collection, the user or experiment controller may need the ability to control functions and make queries from the WPSM computer. Touch screens can be used for this purpose and could take the form of mobile SVGA displays that plug into the WPSM computer or a PDA supporting a wireless interface to the WPSM. In either case, appropriate menus and support for touch-screen selection is required.

System Development, Integration and Testing

For clarity, the previous chapters described elements of a physiological status monitoring system in an independent fashion. However, it is clear that the long-term objective of a nonintrusive, reliable, low-cost, low-power, monitoring system cannot be realized except through a well-planned, end-to-end system integration effort. The dearth of prior experience in implementing the proposed monitoring on a broad scale, coupled with the immaturity of some of the desired technologies, demands that the system integration effort follow a spiral development methodology in which capability is incrementally built up by means of frequent prototyping and field testing. Furthermore, in order to support integration with LW and FFW, “drop-dead” dates must be established for the inclusion of particular technologies. Wherever possible, fallback solutions or configurations should be identified that deliver less capability but carry less implementation risk.

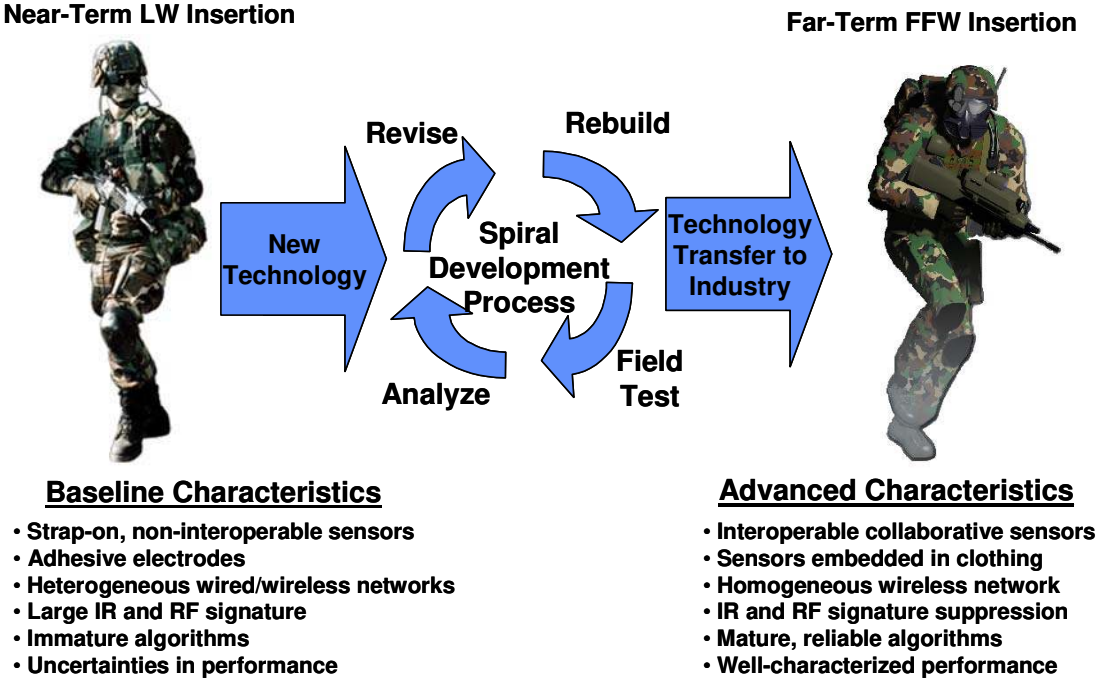

Figure 9.1 – Spiral development process for near-term and far-term WPSM system insertion

Field testing with an increasingly larger number of users in diverse situations is necessary to reveal difficulties at each level of abstraction in the system, to ensure user acceptance of the deployed system, and to demonstrate the value of sensor fusion. Presently the experience and understanding at all levels of abstraction, from the lowest sensor level to the highest levels of system Conops, is inadequate to fully specify and design a system. The lack of understanding extends to both the collection (sensing) and exploitation (processing) of information.

The combination of lack of prior experience and immature technology ensures that a traditional top-down, requirements-driven development process will fail to produce an affordable, reliable, non-intrusive system. Development of both the near-term and far-term systems must follow a spiral development path with frequent laboratory and field-testing of technologies as illustrated in Figure 9.1.

9.1. Near-Term System (IOC)

The near-term system effort should include two parallel, collaborative efforts. The first is a science track that emphasizes collection of the highest-fidelity data across as broad a spectrum of sensors as possible. This track should emphasize the use of existing COTS/MOTS hardware and software, and strive to achieve the greatest degree of ease of use and flexibility in the hardware and software at the expense of size, weight, power, and covertness (signature control). This WPSM R&D platform will be useful in laboratory and field tests. The use of a commercial operating system and software tools will facilitate the evolution of the software for data collection, communication, and information product development. As an example, the Nexan ECG/respiration patch could be interfaced via Bluetooth to a wearable computer in order to collect heart and respiration data. Other sensors could also be interfaced to the commercial computer through wired or wireless interfaces. For example, the RF core temperature system could be interfaced to the wearable computer by means of RS-232 or USB connection between the RF receiver and the computer. The R&D science platform has many uses and, by archiving raw data, sensitivity studies can be conducted and performance metrics can be derived for various system components. Figure 9.2 provides a notional view of the composition and uses for a COTS/MOTS science platform.

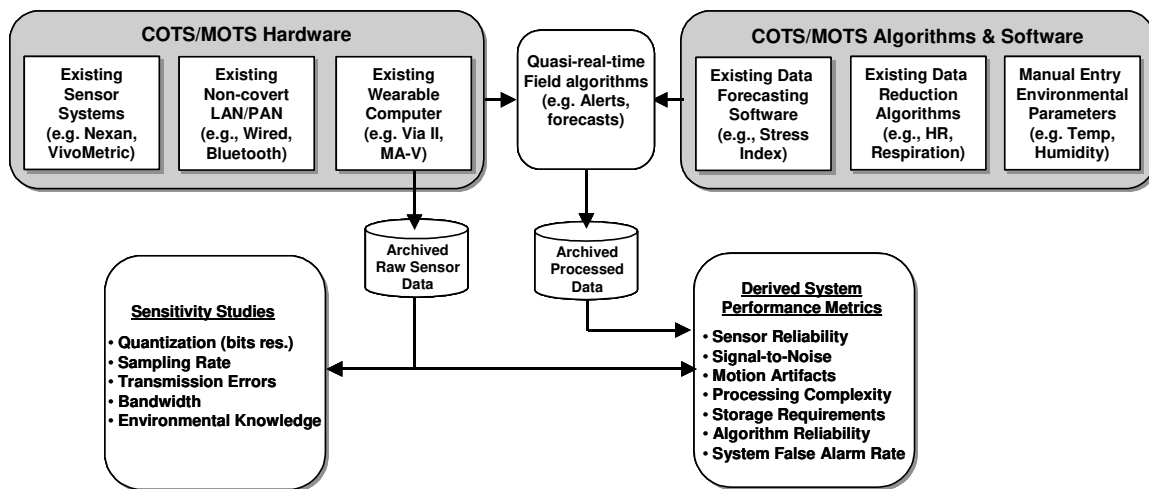

Figure 9.2 – R&D science platform components and uses.

The second track is a hardware implementation track that is focused on a size, weight, power, and signature-constrained implementation of the WPSM system with a suitable interface to LW. The key element of this effort is selecting an appropriate WPAN technology. The processing and memory elements of the system will continue to benefit from commercial developments and Moore’s Law improvements in IC density. However, the FFW has unique WPAN requirements that will not be addressed in the course of commercial development.

The key elements of the WPAN technology are

1. The choice of wireless media
2. The choice of bandwidth and modulation to support multichannel sensing
3. The creation or identification of protocols to support plug-and-play sensors

Based on the issues discussed in Chapter 7, we believe a hybrid PAN consisting of both wired and wireless elements is optimum, with the wireless segment based on a combination of free-space magnetic induction and short-range quasi line-of-sight optical links, the optical link serving either high bandwidth needs, such as a head-up display, or transmission through layers of clothing.

The inclusion of a COTS-based science track allows the collection of high-fidelity data and the development of forecasting algorithms to proceed without being impeded by the development time or performance constraints associated with size, weight and power-constrained hardware. However, as understanding is gained in the science track regarding the importance of different sensor modes, the required bandwidth, the required dynamic range, and the required processing resources, this information can be used to guide the development of the form-factor constrained WPSM system.

In order to meeting LW/FFW integration milestones, the sensors and algorithms incorporated in the form-factor constrained version of WPSM may need to be trimmed substantially relative to the COTS/MOTS developmental implementation. The COTS/MOTS based system collecting high-resolution data affords an opportunity to perform sensitivity studies on both the sensor quality and the algorithm complexity.

Provided the WPAN design is robust, the form-factor constrained WPSM system baseline can be targeted toward simple low-risk sensors and algorithms, with evolution of capability through the addition of higher-performance sensors and more capable algorithms. For example, the baseline form-factor constrained WPSM might support only a diagnostic user interface, offering no real-time control or query capability to the user in the field. The sensor suite might be limited to an R-wave heart-rate monitor integrated into the undershirt, core temperature pill, activity monitor, and inductive plethysmography respiration monitor, also embedded in the undershirt. The RF receiver for the core temperature pill could be integrated with an acquisition module for digitized R-wave and activity monitor signals, while the plethysmography sensor would require a wired interface.

9.2. Integration into Clothing

9.2.1. Motivation

Since comfort (wear and forget) will be a key criterion for user acceptance, avoiding the need to apply adhesive electrodes is an important long-term goal. The image of soldiers strapping or tapping on a variety of physiological sensors prior to an engagement, and then carefully adjusting the cables and testing to ensure connectivity is clearly inconsistent with user acceptance. However, in the near-term, many of the important physiological parameters will require contact sensors of some sort, for example ECG electrodes, respiration bands, skin temperature thermocouples. If adhesives are to be avoided, the sensors must be embedded in appropriate articles of clothing, and the fabric type, cut and fit must be selected to ensure adequate contact between the electrodes and the body. This may require a more tailored approach to some articles of clothing, which may in turn enhance user acceptance if the improved fit required for sensing leads to greater comfort. Embedding sensors in the undershirt or other articles of clothing raises questions about

susceptibility of the sensors to damage from washing and normal daily activities, and the rigors of combat.

9.2.2. Power Options

While the sensors may be wireless in terms of data transfer, an important design issue when embedding sensors in clothing is how to provide power to each sensor. Individual batteries for each sensor would be costly and a nuisance. Some form of distributed power is needed, whether it is in the form of a single battery attached to the undershirt with wires to the sensors, or a centralized battery that couples power into the garment. In terms of reliability, connectors are the bane of electronics, so a wireless means of coupling power into the garment is desirable, essentially a flat form-factor transformer with AC coupling of power.

User acceptance will require that the sensors and network infrastructure be relatively transparent to the user and free of maintenance and manual calibration requirements. The sensors, connectors, and any wiring must therefore be integrated into the standard issue clothing and equipment. Candidate approaches for integrating each class of sensor are described the next section.

9.3. Sensors

9.3.1. Heart rate and ECG

Commercial R-wave heart monitor bands and conductive textiles offer a near-term alternative to the use of adhesive electrodes for heart rate or ECG. However, field data is needed to understand the impact of motion artifacts as well as environmental conditions on any of the non-adhesive sensor options. For example, commercial heart-rate monitors often fail to detect the signal when the skin is dry, as it might be in colder environments.

9.3.2. Respiration

Two methods of respiration sensing in commercial ambulatory sensors have been identified as potential candidates for WPSM: thoracic impedance, and inductive plethysmography. In order to eliminate the need for adhesive sensors, a version of plethysmography belt appears to be the preferred approach. However, field data is needed to understand the impact of motion artifacts on plethysmographic sensing, as well as the susceptibility of the various implementation technologies to damage.

9.3.3. Temperature

Ingestible core temperature sensors are known to provide accurate and reliable temperature, but must be regularly ingested and re-supplied. Supplementing the ingestible temperature capsule with skin temperature sensors, on limbs and the torso, provides the data needed to initialize metabolic and thermodynamic models. Furthermore, it may be possible over time to correlate skin temperature measurements with the core temperature measurements and possibly eliminate (no pun intended) the need for ingestible temperature sensors.

Skin temperature sensors can be embedded in undergarments, with wired connections to drive and readout electronics also embedded in the undergarment.

9.3.4. Activity

The Actigraph wristwatch, described in section 4.2.10, has been employed successfully in field tests to estimate metabolic activity and sleep score. The introduction of MEMS accelerometers into articles of clothing, along with the introduction of load sensors into the

soldier's boots, will enable more sophisticated, and presumably more accurate, estimates of metabolic activity. Metabolic activity estimates can also be improved by fusing heart rate, respiration rate, ambient and core temperature measurements to better characterize the level and duration of activity.

9.4. WPAN

9.4.1. Free-space magnetic induction (wireless) component

There currently is not a WPAN solution that meets the low-power, low-bandwidth, multiuser, covert continuous operation requirements for WPSM. Free-space magnetic induction is an attractive technology for the core element of such a WPAN, and there is some commercial development that might be leveraged. AuraComm is developing a single-chip transceiver that will support a four-channel WPAN, but the channel bandwidth is higher than needed, and the number of channels is smaller than needed. Xemics markets both chip and board-level components for free-space magnetic induction, but at data rates that are lower than desired and without a predefined multiuser access protocol. Since the WPAN is critical to success of the WPSM, a focused effort is needed to define and develop a suitable WPAN and associated protocols. The WPAN may leverage these or other commercial developments, but it is unlikely that a WPAN meeting military requirements will be developed solely for commercial applications.

The free-space magnetic induction WPAN can be implemented in a single chip. Prototypes might be implemented in field-programmable gate arrays (FPGAs) or other semi-custom technology, but a multichannel low-power version in a single chip should be the ultimate goal. The development of a prototype chip in semi-custom or custom form is a one to two year effort with multiple fabrication runs possibly required. Results of field testing with COTS components should be used to drive the design requirements for the WPAN including:

1. Time (sample) synchronization accuracy required
2. Number of data channels required
3. Individual and aggregate data rates required
4. Allowable bit error rate
5. Expected signal losses due to body and equipment blockage
6. Maximum range of operation required
7. Maximum number of concurrent users within the operational range

The WPAN design must ensure that data samples from distributed sensors can be time aligned to the accuracy needed to support fusion of sensor data. The WPAN design must also ensure that adequate signal-to-noise margins exist to support data rate and bit error rate required by the various sensors. In advance of the design, and later as prototype WPAN technology is fabricated, it will be critical to characterize the electromagnetic signature of the WPAN in the far-field and establish the standoff detection and intercept range of the WPAN. The WPAN must be continuously powered in order to support continuous physiological monitoring. However, WPAN technology will obviously not be carried by the soldier if it can be exploited by the enemy to detect and possibly geolocate the soldier at stand-off ranges.

9.5. Spiral Development Plan

Traditionally, the military has taken a waterfall or top-down requirements approach to both the development and procurement of systems. This approach starts with a set of user requirements and invests heavily in the development of a system definition and preliminary design followed by a critical design review and fabrication of the system. It is important to note that while the intent is for WPSM to be a small, low-power, unobtrusive system, it is nonetheless a complex system spanning many disciplines from sensors and wireless networks to physiological modeling and forecasting. If physiological status monitoring in combat conditions were already a mature, well-characterized endeavor, a top-down, waterfall development process might be successful in producing a deployable system.

However, while there have been numerous laboratory experiments and field tests of specific physiological status monitoring functions, there is virtually no successful experience with an appropriate system implementation of such a capability. For example, while commercial ambulatory monitoring systems exist, they function in a relatively benign environment, require adhesive sensors, and are usually designed to function for a day or less on battery power. Furthermore, commercial ambulatory systems are designed primarily to collect data, with the processing and data reduction to useful data products occurring in non-real-time on computer workstations. The lack of experience with real-time physiological monitoring of individuals in a combat environment for time periods of 72 hours or more leads to uncertainty regarding exactly what the significant impediments to implementation will be. Some of the issues that need to be more clearly understood and prioritized, prior to implementation of a deployable system include:

- Sensor reliability
 - Performance trades (e.g., electrodes vs. Photrodes)
 - Susceptibility to environmentally-induced failures (temperature, shock)
 - Sensitivity to motion artifacts
 - Methods for built-in testing and calibration
- Wireless network
 - Protocols for network access and data transfer
 - Maximum number of sensors and aggregate bandwidth requirements
 - Preferred wavelength driven by consideration of bandwidth and latency requirements, stand-off detectability, blocking losses and multi-user interference
 - Network reliability including sensitivity to body blockage, equipment blockage, co-located users, EMI
- Time and location synchronization
 - Required accuracy of data time-stamping
 - Methods for synchronizing sampling of distributed sensors
 - Benefit of incorporating geolocation information
- Sensor positioning
 - Methods for attachment including integration with clothing including
 - Optimal locations for maximizing SNR
- Algorithms
 - Desired derived performance and forecast objectives
 - Physiological and environmental parameters required
 - Methods for fusing heterogeneous sensor data
 - Methods of statistical inference
 - Computational complexity and storage requirements
 - Reliability of derived performance measures and forecasts

- Data management and products
 - Data archiving policy
 - Methods for retrieving archived data (e.g. combat medic access)
 - External report content and frequency
- Power requirements
 - Average power required
 - Methods for supplying power to sensors
 - Power-saving modes of operation (minimum required monitoring)
- Integration
 - Methods of incorporating sensors and wiring into clothing
 - Mix of wireless and wired connections
 - User interface requirements
 - Physical and protocol interfaces to LW/FFW

In addition to these open issues, the draft performance requirements for a WPSM system implementation are challenging, requiring an aggregate system weight of 450 g or less, with no negative impact on user mobility or comfort. Consequently, the selection of sensors, networking, and processing components must be performed carefully, with consideration of both the performance goals and the integration issues. For example, the *SenseWear Pro* Armband shown in Figure 3.10 weighs only 82 g exclusive of batteries, but is able to measure heart rate, acceleration, galvanic skin response, skin temperature and air temperature. The Armband is an example of a tightly integrated group of low-complexity sensors. In terms of the WPSM requirement, we note that there is no significant on-board processing or data reduction of the sensed information. Nevertheless, it demonstrates the feasibility of implementing low-power, lightweight integrated sensor suites. In comparison, the *VitalSense* monitor pictured in Figure 4.6, which currently supports only skin and core temperature sensors, weighs on the order of 200g, nearly half the weight allowance for the entire WPSM System quoted in the draft requirements of Appendix F. A significant integration and packaging effort will therefore be required to meet the draft performance weight limit for WPSM. However, the integration effort should only be undertaken once the appropriate suite of sensors, networking, algorithms, and processing are well defined and tested.

Convergence to a tightly integrated reliable suite of sensors and algorithms for WPSM that meet the draft performance goals will be possible only if the open issues listed above are first addressed. For most of these issues, field testing of sensors, networks, algorithms and processing will be necessary, with multiple iterations of the testing to quantify various combinations of the subsystem components. We envision a progression from a non-conforming COTS/MOTS hardware platform hosting current state-of-the-art sensors and algorithms to a custom implementation of the WPSM hardware with sensors and algorithms tailored to meet the performance requirements for a deployable WPSM.

As illustrated in Figure 9.3, we envision spiral development initially proceeding along several parallel but coordinated subsystem paths. Science and technology issues are addressed initially and throughout the design definition phase with a COTS/MOTS platform. The COTS/MOTS platform eases software development and experimentation, while providing resources to allow the highest fidelity of data collection and analysis.

Information gleaned from experiments and tests using this science and technology platform feeds into the development and evaluation of components for the three major subsystems comprising; the WPAN, the suite of physiological and environmental sensors, and the algorithms for data collection, archiving, fusing and forecasting. At various times these four

concurrent development paths may join together for collaborative experiments. For example, elements of the evolving sensor technology will need to be tested with elements of the evolving WPAN to ensure the integrity of sensor interfaces. However, much of the sensor evaluation, such as sensitivity to motion artifacts, can proceed without the benefit of the WPAN. Similarly, characterization of the WPAN in terms of body blockage losses, bit-error rate, and susceptibility to standoff detection can occur apart from the specific details of the sensors or the data processing. Even with concurrent development paths, there is much work to be performed in terms of iterative field experiments with the various subsystems before transitioning to a form-factor constrained integrated design of the overall WPSM. The development of the subsystem components will require input from a variety of specialists possessing expertise in RF design, networking protocols, electronic textiles, physiology, thermodynamics, chip design, and system integration and testing.

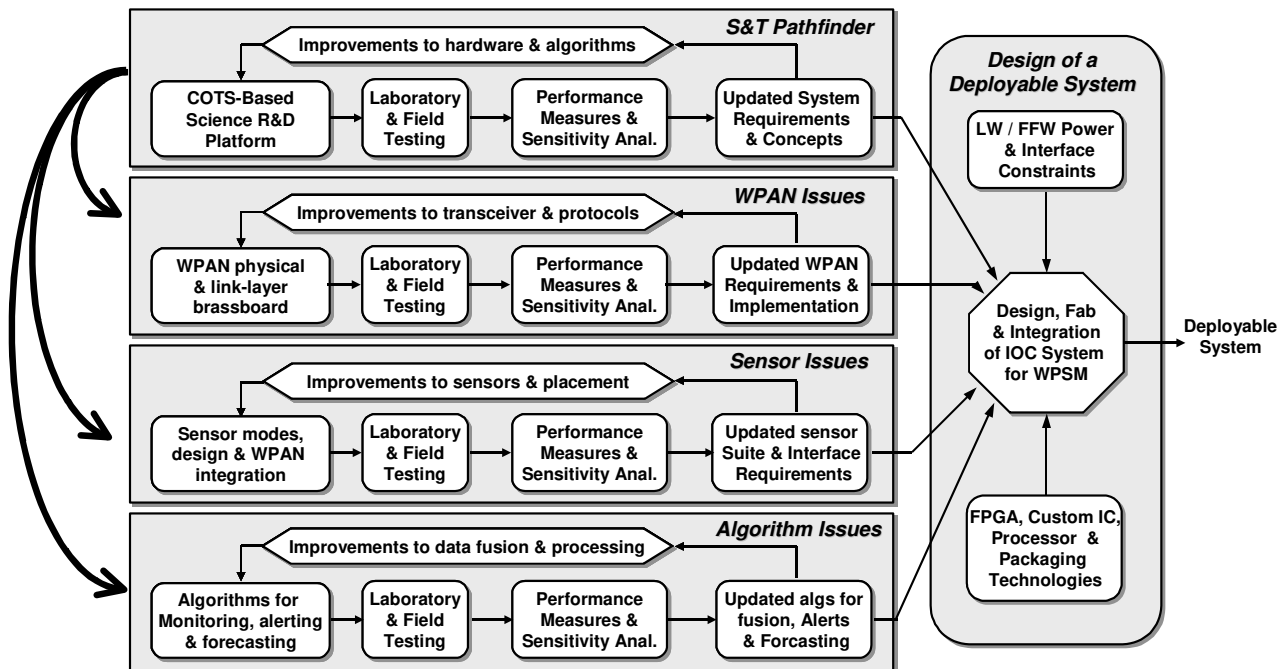

Figure 9.3 Spiral design based on concurrent, iterative development and assessment of subsystem components followed by a later phase of design emphasizing form-factor constraints

Near-Term System Concept

10.1. Near-Term Constraints

In this document, a near-term system is defined as one for which a baseline capability can be fielded in 2–3 years. A key constraint in defining a near-term system is that FDA certification of the system must be possible by demonstrating that the system employs previously certified and approved technologies. A second important constraint in defining a near-term system is that the baseline architecture must be scalable and sufficiently flexible to accommodate incremental upgrades to the sensors, software, processing, and the Land Warrior interface.

Based on the market survey performed for this study, capabilities for the near-term baseline system are defined with the constraints of COTS technology in mind. Existing commercial systems and products are referenced for the sole purpose of demonstrating feasibility of the proposed baseline system. We anticipate that a Broad Industry Announcement (BIA) may uncover additional technologies that were not identified in the market survey, so the baseline system defined in the next section should only be viewed as a representative example.

10.2. Baseline System

According to the draft WPSM specification, Appendix F, the functional capabilities and certifications required in a near-term system include

1. Life sign detection
2. Hemorrhagic shock detection
3. Respiratory distress detection
4. Thermal stress risk determination
5. Interface to Land Warrior computer
6. Sleep state determination

Another feature that is desirable and technically achievable in the near-term system is acoustic sensing, including possibly ballistic impact detection and localization.

10.2.1. Sensors

Sensor technology available for integration in a near-term system includes

- Two-lead ECG
- Respiration rate
- Skin and core temperature
- Air temperature

- Acoustic microphone
- Accelerometer for activity sensing
- Fluid intake (drink-o-meter)

10.2.1.1. ECG

Ultimately an ECG based on wireless, dry-electrode sensors embedded in the soldier's undershirt is desired. In the near term, the objectives are

1. Minimize the effort and skill required to apply adhesive electrodes
2. Ensure reliable connections between the electrodes and processor or WPAN
3. Ensure user comfort
4. Accommodate variable layers of clothing

The Nexan sensor patch described in Section 3.3 meets all four of these near-term requirements and provides a two- or three-lead ECG as well as thoracic impedance-derived respiration rate. The Nexan disposable patch and wireless RF interface provides an FDA/FCC certified near-term method for sensing two of the important life signs. Without expanding the scope of the current sensing functions, a number of modifications could be introduced into the system to make it better suited for military field tests and potential transition to an operation capability. These improvements are technically achievable but are not necessarily part of Nexan's current commercial development strategy.

1. The sensor patch and Sender system batteries can be made replaceable or wired to external power to support operation of the patch beyond the nominal 24 hours
2. The sampling rate of the sensor systems can be made adjustable, including the ability to either lower the rate of continuous sampling or putting the sampling in sleep mode for predetermined periods
3. The RF system for archiving data can be upgraded to a multiuser open wireless technology (e.g., 802.15.4 or magnetic induction) or to a custom RF system designed to meet additional military requirements of signature control and power efficiency.
4. The data archival unit can be upgraded with a programmable processor capable of pre-screening data for anomalies and saving only anomalous data
5. The base station can be eliminated and the PDA data uploaded directly to the workstation.
6. The software can be ported to a laptop to facilitate field data collection and analysis

In parallel with the use of the Nexan patch technology, the conductive textile technology described in Appendix B should be pursued as an alternative to the adhesive electrode technology, with the goal of providing dry-electrode sensors embedded in the soldier's undershirt at the completion of the near-term development effort.

10.2.1.2. Respiration

In the near-term, the Nexan sensor patch can be employed to measure respiration by means of thoracic impedance. A transition to a resistive or inductive plethysmography belt is recommended in order to eliminate the need for adhesive electrodes. Ultimately, the plethysmographic belt should be integral to the soldier's undershirt. However, in a near-term system the belt might be held in place through loops attached to the undershirt.

For the Nexan implementation, the improvements suggested in Section 10.2.1.1, are applicable as well to the thoracic impedance measurement hardware and software.

10.2.1.3. Core and Skin Temperature

The Mini Mitter core-temperature pill described in Section 4.2.4.1 has proven to be a reliable and accurate means of measuring core temperature. In the near term, the existing RF receiver and data logging unit can be interfaced to either a wired or wireless PAN in order to integrate the temperature data with other sensor data. In the long term, the RF pill could be modified to be interrogable directly over the WPAN.

The skin-temperature sensor integrated with the actigraph wristwatch provides a compact sensor suite. However, the accelerometer and temperature sensors must be interfaced to the PAN in order to provide real-time access to these measurements. The Mini Mitter actigraph supports a wired interface to a data logger, but a wireless interface is needed to allow a full range of motion by the user and to avoid reliability issues associated with wired connections. In the near-term, a wired connection from the cuff of the BDU to the watch may be admissible until such time as the WPAN is available.

10.2.1.4. Acoustic

ARL has been experimenting with acoustic sensors matched to the impedance of the body and has shown some success in detecting heart rate, respiration, coughing, and blunt/penetrating phenomena. WRAIR has also funded work on a ballistic impact detection system (BIDS), which exploits acoustic detection and localization of ballistic wounds. Therefore, one or both of the microphone technologies associated with these research efforts should be incorporated into the suite of sensors. The range of acoustic signals of interest, and the need for fine time resolution to perform localization through time-delay direction of arrival will require high sampling rates relative to other signals, such as ECG and respiration. Therefore, inclusion of one or more acoustic sensors may drive the overall bandwidth requirements of the WPAN. In the near term, an acoustic sensor system may need to be implemented as an independent subsystem, with wired sensors and dedicated processing to reduce the data rate prior to interfacing to the WPAN. An acoustic sensor is probably the most stressing of the near-term sensor requirements because of the high data rate required relative to other physiological sensors.

10.2.1.5. Activity

USARIEM already has experience with the actigraph wristwatch as a tool for estimating sleep state. As noted in Section 10.2.1.3, the remaining challenge is to interface the actigraph sensor to the WPAN.

10.2.2. PAN

In the near-term system the PAN will of necessity be a hybrid of wired and wireless connections. In the far-term system, miniaturization of the sensors, data acquisition hardware, and wireless transceivers may enable an all-wireless distributed system.

10.2.2.1. Wired Subsystems

Certainly in the near-term, portions of the WPSM sensor suite will be wired for both power and data transfer. For example, the Nexan sensor patch incorporates flexible ribbon connector to connect ECG and respiration electrodes to the data acquisition and wireless sender hub. In the evolution of the sensor technology, the first step is to move from gel-coated adhesive electrodes to dry contact sensors, preserving the wired connections but incorporating the wires into the undergarments through so-called electronic textiles. However, in order to move toward a deployable system and conduct realistic field tests, a wireless PAN will be needed to support communication through layers of clothing and to provide flexible positioning of sensors.

10.2.2.2. Wireless Backbone

Commercial standards such as 802.11 can be employed at the outset of development to provide high-bandwidth data collection and diagnostic links with COTS computing resources. However, a lower-power, short-range, less complex WPAN solution is required to meet the weight and power goals of the WPSM specification. The recommended approach to realize this low-power WPAN is to pursue a near-field magnetic induction technology similar to the Auracom LibertyLink described in Section 7.4.2.2. The goal should be to provide support for 8 or more wireless plug-and-play sensor connections, with aggregate bandwidth sufficient to support the worst-case sampling rates of the suite of sensors.

10.2.3. Processing

10.2.3.1. Hardware

A wearable computer with Windows operating system may initially serve as host to the development system. This approach allows the maximum flexibility in developing algorithms and interfacing disparate sensors. Representative wearable computers are the *Via* from Infologix and the MA-V from Xybernaut, shown in Figure 10.1. The *Via* utilizes a power-programmable CPU and is available in a ruggedized version that will withstand immersion. The salient parameters of the *Via* and MA-V are listed in Table 10.1.



Figure 10.1 – (a) Infologix ViA II Super Rugged with Caruso Transmeta processor (b) Xybernaut Mobile Assistant V with Celeron ultra-low voltage processor

Table 10.1 Comparison of Two Commercial Wearable Computer Systems

Parameter	<i>Via</i>	<i>MA-V</i>
Size	6.0" (L) x 3.9" (W) x 1.6" (H)	5.9 "x 3.5 "x 2 "
Clock rate	667 MHz or 1 GHz	500 MHz
Memory	128 MB	128 MB
Disk storage	6.4 GB	5 GB
Power dissipation	4–5 W	4–5 W
Weight with batteries	3 lbs	1 lb
Integrated interfaces	USB, RS-232	USB, RS-232, FireWire
PCMCIA slots	2 Type II	1 Type II or III
Flash HDD option	Yes	Yes

Clearly the computer size, weight, and the battery endurance of less than 6 hours are incompatible with the performance specifications for the initial WPSM system. The availability of two Type-II interface card slots in the *Via* allows the use of 802.11 or other suitable standard to provide a wireless interface from the Nexan ECG/respiration patch to the computer. The USB and RS-232 interfaces or a custom Type-II card may be exploited to interface to temperature and activity sensors. However, these commercial WLAN components are inappropriate for a deployable, low-power system.

As experience with this development platform is gained through laboratory and field tests, a smaller, lower-power implementation specialized to the needs of WPSM is needed. This

implementation might be based on a low-power, credit-card sized computer running Linux or a combination of FPGA and core processor technology. The semicustom implementation would also incorporate the selected wireless protocol.

10.2.3.2. Algorithms and Software

Algorithms for interpreting and reducing high-quality ECG, respiration, and temperature signals are well established. The challenge for WPSM is to develop collaborative algorithms that can ascertain when a particular physiological signal is reliable, and that can improve the estimation of physiological parameters through appropriate fusion of the heterogeneous signals. The discussion in Section 6.4 of an algorithm for determining life sign status represents an example of how the information from multiple sensors can be used to infer reliability of a particular sensor signal.

Algorithms for determining the onset hemorrhagic shock and hypovolemia are less well defined and are strongly dependent upon the quality of derived measures such as blood pressure and body temperature.

In general, the algorithm requirements are going to be driven strongly by the success of the sensor positioning, motion artifacts, and the WPAN reliability. To the degree that sensor position results in poor SNR, artifacts introduce noise, or the WPAN experiences data dropouts, the data reduction and fusion algorithms must be designed to at least recognize flawed data, and perhaps infer missing information through appropriate filtering and correlation of heterogeneous signals.



10.2.4. Land Warrior Interface

Supporting an interface to the Land Warrior is not a technical challenge, given the existence of a WPSM development-phase computer. A variety of physical interfaces can be supported including RS-232 and USB.

10.3. Technology Maturity

Table 10.2 contains a three-color ranking of the state of maturity for each of the components or subsystems that comprise a near-term physiological status monitoring system. A maturity estimate is made in each of five categories ranging from demonstration of functionality to readiness for integration in a deployable WPSM system.

Since the component and subsystem categories are broad, the maturity rankings are also broad. If we attempt to assign a correspondence between TRL levels and the three broad levels of maturity employed in Table 10.2, the correspondence between the maturity symbol and TRL level is

	TRL in the range 6–9
	TRL in the range 4–5
	TRL in the range 2–3

However, since TRLs are intended to be defined in an overall system context, the correspondence above must be understood in light of the particular category. For example,

consider the “Function” column in Table 10.2. The sensing functions for the various physiological parameters have all been demonstrated in one form or another and are therefore considered “green.” In contrast, the sensor “Form” (packaging) and the “Reliability” (sensor attachment and robustness to motion artifacts) have generally not been demonstrated for a combat environment. However, by fusing information from multiple sensors and defining appropriate built-in sensor tests, it may be possible to successfully integrate the sensors into a near-term system; hence, the form, reliability, and integration are generally give a “yellow,” or TRL 4–5 designation.

As indicated in Table 10.2, the individual sensor technology is relatively mature. The most significant impediments to realizing a near-term wear-and-forget system are the lack of a robust low-power WPAN and robust algorithms for life sign detection, hemorrhagic shock, ballistic impact, fusion of heterogeneous sensor data, and built-in testing and calibration.

Table 10.2 Technology Maturity Ranking of Components and Subsystems

<i>Component or Subsystem</i>	<i>Function</i>	<i>Form</i>	<i>Power</i>	<i>Reliability</i>	<i>Integration</i>
Sensors					
• ECG	Green	Yellow	Yellow	Yellow	Yellow
• Respiration	Green	Yellow	Yellow	Yellow	Yellow
• Skin Temperature	Green	Yellow	Green	Green	Green
• Core Temperature	Green	Yellow	Green	Green	Green
• Acoustic	Green	Yellow	Green	Green	Green
Processor	Green	Yellow	Yellow	Yellow	Yellow
PAN					
• Electronic textiles	Green	Yellow	Green	Red	Red
• Wireless	Green	Yellow	Yellow	Yellow	Red
• Protocols	Yellow	Green	Green	Yellow	Red
Algorithms					
• Heart Rate	Green	Green	Green	Yellow	Yellow
• Respiration Rate	Green	Green	Green	Yellow	Yellow
• Stress Index	Green	Green	Green	Yellow	Yellow
• Life Sign Detection	Yellow	Green	Green	Red	Red
• Hemorrhagic shock	Red	Green	Green	Red	Red
• Sleep State	Green	Green	Green	Yellow	Yellow
• Ballistic impact	Yellow	Yellow	Yellow	Red	Red
• Fusion Framework	Yellow	Yellow	Yellow	Yellow	Red
• Built-in Test	Yellow	Yellow	Yellow	Yellow	Red
• Calibration	Yellow	Yellow	Yellow	Yellow	Red

10.4. Near-Term WPSM Baseline System Concept

The near-term baseline for a WPSM system is summarized in Figure 10.2. The display and GPS location functions are assumed to be available from the Land Warrior System.

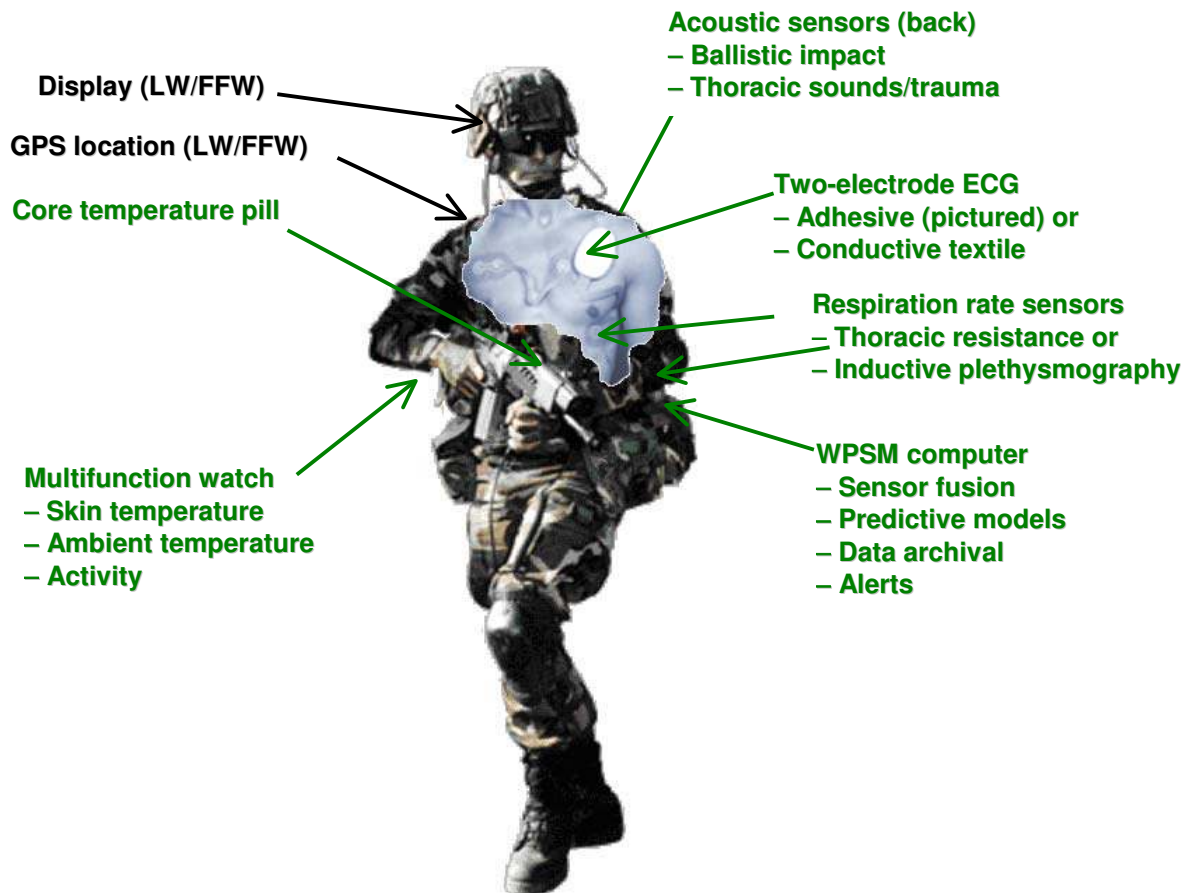

Figure 10.2 – Near-Term WPSM Baseline System Concept

10.5. References

- [1] M. Scanlon, "Acoustic Sensors in the Helmet Detect Voice and Physiology," *SPIE Proceedings*, Vol. 5071, 21–25 April 2003, pp. 41–51.

Far-Term System Concept

This chapter describes a strawman far-term physiological monitoring system concept and discusses the technology system investments needed to evolve from a near-term (~FY05) system to an advanced system with capabilities similar to those outlined in this chapter.

11.1. Far-Term Constraints

In this document, a far-term system is defined as one for which initial operating capability (IOC) can be demonstrated in 8–10 years (~2014). Due to the long time frame associated with a far-term system, we do not attempt to separate the elements of the system into WPSM versus broader FFW capabilities. In other words, we do not identify which program element within the Army will develop a particular technology; rather, we simply identify the components and capabilities that comprise the overall WPSM/FFW system.

11.2. Capability Envisioned

The far-term system includes the functionality of the near-term system with improved implementations and performance of the baseline capabilities of the near-term system. In addition, the far-term system provides significantly enhanced functionality through the use of new sensors, new physiological features, and improved data fusion and multisensor inference. The capabilities and characteristics envisioned in a far-term system include

1. Tight integration with the FFW WPAN, computer and squad radio
 - a. Plug-and-play WPAN supporting medical and non-medical sensors
 - b. Direct-write retinal display
 - c. Biometric user authentication
2. Dual-use networked sensors including
 - a. Acoustic
 - b. Visible imagers
 - c. Biological
 - d. Chemical
 - e. Radiological
 - f. Geolocation
3. Physiological state and performance monitoring
 - a. Heart rate
 - b. Respiration rate
 - c. Neurological function
 - d. Core and skin temperature

- e. Activity level
 - f. Retinal vasculometry
 - g. Mental alertness
 - h. Food and water consumption
4. Environmental monitoring
- a. Ambient air temperature
 - b. Solar irradiance
 - c. Wind speed
 - d. Visual imagery
 - e. Chemical agents
 - f. Biological agents
 - g. Radioactivity
5. Derived information
- a. Blood volume
 - b. Blunt trauma events and localization
 - c. Burn trauma events and localization
 - d. Respiratory distress
 - e. Sleep quotient
 - f. Metabolic activity level
 - g. Altitude adaptation status
 - h. Integrated CBRN exposures
 - i. Physiological stress index
 - j. Life-sign detection

11.3. Sensor Evolution

As experience is gained with the near-term system's sensor performance and artifacts, the sensors for ECG/heart rate, respiration, and temperature can be migrated into clothing and designed to reduce sensitivity to motion artifacts. In addition, the built-in test algorithms can be evolved to provide a reliable indication of sensor status.

11.3.1 New Capability

In addition to improvements in existing sensor technology, new classes of sensor will be added. Several of the anticipated sensor technologies are described in the following sections.

11.3.1.1. Imagers

Active pixel imagers can be added to the periphery of the helmet. These imagers will be a fraction of a square inch in size and require only microwatts of power in standby mode. A micro gimbal will allow the sensors to be stowed in a downward pointing direction to avoid standoff detection from lens reflection. The sensors will have a dual-use capability, the primary mode being real-time imagery of surroundings to higher-level command. However, under remote command of a medic, the helmet-mounted sensors can also be rotated

downward to provide oblique views of the body as an aid to remote triage and injury assessment.

Imagers will also be embedded in the head-up display. As illustrated in Figure 11.1, the head-up display itself may be a retinal display in which imagery to be presented to the user is focused directly on the retina. This approach minimizes the power required, as well as the visible signature associated with the display. Portions of the optical chain employed in this direct-write retinal display can also be used to image layers of the eye including the eyelid, the cornea/iris, and the retina. Imaging the eyelid provides information on sleep state/consciousness. Imaging the iris provides a feature for biometric identification and authentication. Iris imaging also provides a means of assessing alertness by measuring the response of the iris to a controlled light source. Imaging and color-selective filtering of the retina provide information on arterial vessel structure and diameter. This information is another source of biometric identification and authentication. More importantly, there is evidence that retinal vasculometry may provide a reliable, nonintrusive means of detecting hypovolemia. The approach is outlined in Appendix E [2].

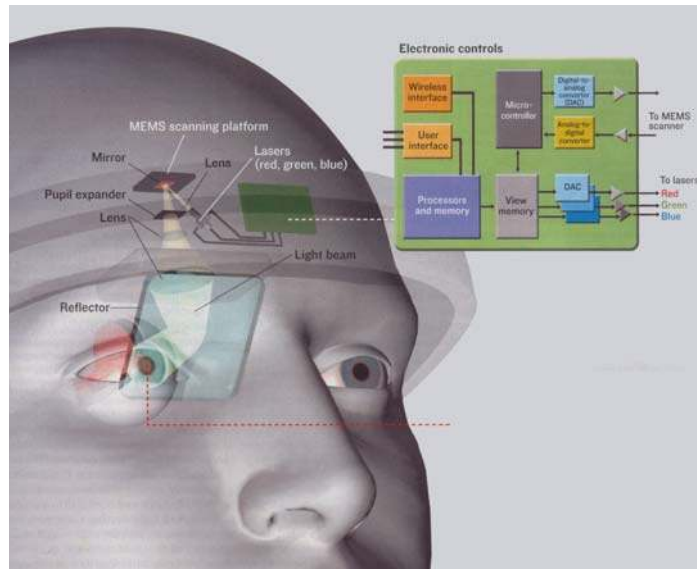

Figure 11.1 – Retinal scanning head-up color display technology [1]

11.3.1.2. Brain Function

In addition to providing a platform for the head-up display and imagers, the helmet liner will be instrumented with one or more sensors to monitor direct or indirect indications of brain activity. The Photrode technology discussed in Section 4.2.2, currently in the research stage, or some other form of dry-contact electrodes will be embedded in the custom fit helmet liner to enable the collection of EEG signals. Motion artifacts may preclude EEG data collection in a dynamic situation, but as confirmation of sleep state, or in assessing life sign status, EEG signal-to-noise ratios may be sufficiently high to enable reliable collection and interpretation of brain waves. As an indirect measure of brain health, cortical oximetry data can be collected, again through the mechanism of sources and detectors embedded in the helmet liner.

11.3.1.3. Load and Acceleration Sensors

As illustrated by the example in Section 4.2.5.1, MEMS research is increasingly demonstrating a wide array of small, low-power sensors for measuring temperature, pressure, acceleration, and load. In the future, MEMS acceleration and load sensors incorporated into articles of clothing will be able to provide detailed information to characterize the kinematic/dynamic movement of an individual as well as the loads and shocks experienced by the individual. Combined with geolocation information derived from GPS, the knowledge of the individual's translational motion, combined with kinematic information and loads, should enable accurate estimation of numerous derived quantities such as metabolic activity level and form of locomotion.

11.3.1.4. Toxic/Hazardous Agent Sensors

Research to develop small, low-power detectors and identifiers for a range of biological and chemical agents is underway, and it is likely that sensors will be available in the time frame under consideration to detect certain types of agents at certain minimum concentrations. These sensors will serve to alert the individual to the existence of a hazardous substance so appropriate action may be taken to avoid exposure or quickly treat for exposure. In addition, the information from the personal sensors can be combined to provide a more global picture of the area affected by an agent release and the extent of exposure. The integration of the detections from personal sensors will require that these sensors link their data through the FFW comm system to a tactical operations center (TOC) or higher-level command center for fusion and forecasting.

In the case of radiological hazards, commercial pager-size systems are available now. Figure 11.2 is an example of one such system. Since these sensors will be worn over the external layers of clothing, a WPAN interface is preferred to move the sensor detection and classification information into the WPSM database.



Figure 11.2 – Gamma radiation detector and alert system

11.4. WPAN

The WPAN will evolve and perhaps merge with the FFW WPAN, supporting plug-and-play equipment beyond that required for physiological status monitoring. For example, we envision that ammunition and other types of equipment will be packaged with a disposable, long-shelf-life battery so that whatever equipment the soldier is carrying will be discernable by issuing a query over the WPAN. The functions of the WPSM computer will be subsumed in the FFW computer although WPSM hubs may still exist for the collection and time stamping of data from distributed sensors. These hubs will be embedded in the clothing with wireless transfer of data through layers of clothing to the FFW computer via the WPAN.

11.5. Derived Information Products

In addition to the baseline physiological parameters of heart rate, respiration rate, and core temperature, the additional sensing modes and the proliferation of sensors by means of integration with clothing will enable the derivation of many new information products, some of which are discussed in the following sections.

11.5.1 Blunt Trauma Localization

Acoustic microphones embedded in the undershirt will enable the detection of pressure waves associated with ballistic impact on the torso. A bearing to the impact location will be available through the time-difference of arrival techniques. Overpressure from explosions can also be measured through embedded strain gauges. Correlating strain-gauge measurements with acoustic measurements enables discrimination between a localized ballistic wounding event versus an explosion.

11.5.1.1. Burn Trauma Localization

Temperature sensors embedded in the external layer of clothing provide important boundary condition information for thermal modeling and heat-stress forecasting. However, the

embedded temperature sensors also provide a means to sense exposure to high heat sources (fire or explosion) and to establish the duration, intensity, and direction of the heat source. This information can be useful in estimating the likelihood and extent of burn injuries.

11.5.1.2. Metabolic Activity

In comparison to the actigraph wristwatch and integrated skin-temperature sensor envisioned in the near-term system, distributed accelerometers, thermistors, and load-bearing sensors will enable much better estimation of metabolic activity in the FFW system. Analyzing the accelerations from head, torso, arms, and legs will provide information to classify the particular activity such as walking, running, or lifting. Load-bearing sensor measurements combined with the kinematic analysis will allow an intensity to be assigned to the activity. The activity class and intensity can then be correlated with core and skin temperature to refine the estimate of metabolic activity.

As a special case, accelerometer measurements, combined with temperature, respiration, heart rate, and possibly EEG, provide a mechanism for more precisely characterizing sleep state and total hours accumulated at the various sleep state-levels.

11.6. Future Force Warrior Integration

The WPSM software will reside on the FFW computer and functions as a user application. The user will be able to control the amount of information displayed including enabling or disabling certain alerts.

11.7. Technology Maturity

Given the rapid pace of technology evolution, attempting to assign TRL maturity numbers to the technologies needed for a system in 2014 is probably not a valuable exercise. We believe all of the technology concepts presented here for a far-term system are achievable, given sufficient funding for research and development. The issue is then one of prioritizing the technologies of interest and assuring sufficient funding to bring the technologies on line at the proper time.

11.8. Far-Term WPSM System Concept

The salient technologies and concepts for a far-term WPSM concept are summarized in Figure 11.3.



Figure 11.3 – Far-term concept for integration of WPSM into FFW ensemble

11.9. References

[1] J.R. Lewis, "In the Eye of the Beholder," *IEEE Spectrum*, May 2004, pp. 24–28.

[2] A. M. Siegel, "Measuring circulating blood volume through retinal vasculometry," MIT Lincoln Laboratory, patent pending, US patent application number 20040064057.

Theory and Performance of Free-Space Magnetic Induction Headset

A.1. Introduction

This appendix addresses the feasibility of using magnetically coupled coils for very-short-range wireless communications. Coupled coils are attractive because their range is limited to a few meters, mitigating jamming and security concerns, and they are relatively low-cost in comparison with RF systems. In addition, RF systems generally require higher power, and thus a larger battery. The Nasaco MG9030 wireless headset, a commercial wireless telephone headset that uses the first-generation AuraComm chip set is examined in this memo. Theoretical expressions for its transmit/receive characteristics are derived in order to understand its operation. In addition, the unit's performance was measured in the MIT Lincoln Laboratory antenna measurement facility, and the measured performance is compared with the theoretical predictions.

A.2. Basic Operation

The Nasaco MG9030 wireless headset consists of two pieces—a headset and base unit. The headset transmits at 413.7 kHz while the base unit transmits at 1.784 MHz. The voice signal from the headset is modulated onto the carrier and fed to a transmitter coil antenna. The transmitted signal is picked up by the receive antenna array located in the base unit. The receive circuitry demodulates the signal and converts it back down to baseband voice where the output audio can be fed to another device, such as a phone or computer. The base unit operates the same way, at a different carrier frequency, to transmit voice data back to the headset. The same communications chip is used, with minor modifications, in both the headset and base unit. Figure A.1 shows the internals of the base unit.

The base unit contains two antenna arrays—one for transmit and one for receive. Each of the arrays consists of a set of three coils oriented orthogonally to each other in order to eliminate polarization sensitivity.



Figure A.1 – Nasaco base unit packaging and circuit board

A.3. Theory of Operation

The first thing to note about the unit is that the antenna coils are about 0.75 inches long, and the transmit frequency is 1.7 MHz. The RF frequency corresponds to a wavelength of about 176 meters and the coils are a very small fraction of a wavelength. At such long wavelengths, the transmit and receive coils barely qualify as bona fide antennas, and their interaction can accurately be described as a pair of magnetically coupled coils as in conventional low frequency circuit theory. Figure A.2 shows the coil geometry we are considering. The coils are situated end-to-end in an "endfire" configuration.

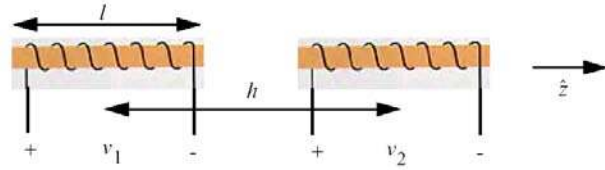

Figure A.2 – Endfire configuration for analysis of transmit and receive antenna coils coupling

The length of each coil is l and the distance between the coil centers is h . The coil voltage relationships are given by the low-frequency expressions:

$$v_1 = j\omega L I_1 \quad (1)$$

$$v_2 = j\omega I_1 M_{21} \quad (2)$$

where v_1 is the impressed voltage across the first coil, L is the self-inductance of each of the coils, and v_2 is the voltage induced across the second coil due to the first coil.

The mutual inductance between the coils is given by

$$M_{21} = \frac{N \int \vec{B}_1 \cdot d\vec{s}_2}{I_1} \quad (3)$$

where \vec{B}_1 is the magnetic field of the first coil evaluated at the second coil, \vec{s}_2 is the area of the second coil, I_1 is the current through the first coil, and N is the number of loops in the second coil. The numerator in Equation 3 is simply the flux through every turn of the second coil due to the magnetic field of the first coil.

The z-directed axial magnetic field of a single wire loop carrying a constant current I is given by [1]

$$B_z = \frac{\mu I a^2}{2(a^2 + z^2)^{3/2}} \quad (4)$$

where a is the loop radius and z is the axial distance from the center of the loop.

For a coil with n turns per unit length, as in Equation 2, the magnetic field due to a differential length of the coil, dz' is

$$dB_z = \frac{\mu I a^2 n}{2(a^2 + (z - z')^2)^{3/2}} dz' \quad (5)$$

where z' is the location of the loop along the z axis. The axial magnetic field due to the entire coil is

$$B_z = \int_{-l/2}^{l/2} dB_z \quad (6)$$

$$B_z = \frac{\mu I a^2 n}{2} \int_{-l/2}^{l/2} \frac{dz'}{[a^2 + (z - z')^2]^{3/2}} \quad (7)$$

Carrying out the integral, we obtain for the axial magnetic field of a single coil:

$$B_z = \frac{\mu I n}{2} \left[\frac{z + l/2}{\sqrt{a^2 + (z + l/2)^2}} - \frac{z - l/2}{\sqrt{a^2 + (z - l/2)^2}} \right] \quad (8)$$

So, the axial magnetic field of the first coil at a position along its axis is given by

$$B_1(z') = \frac{\mu I n}{2} \left[\frac{z' + l/2}{\sqrt{a^2 + (z' + l/2)^2}} - \frac{z' - l/2}{\sqrt{a^2 + (z' - l/2)^2}} \right] \quad (9)$$

According to Equation 3, we must evaluate the flux through each of the links of the second coil. The area of the second coil is

$$S_2 = \pi a^2 \quad (10)$$

and the flux through an incremental length of the coil, dz' , is given by

$$d\phi(z') = \pi a^2 B_1(z') n dz' \quad (11)$$

where n is the number of turns per unit length for the second coil.

This flux is linked to every turn of the second coil, and the total flux is then given by

$$\phi_{total} = \int_{coil_2} d\phi(z') \quad (12)$$

Combining expressions, the mutual inductance between the coils is given by

$$M_{21} = \frac{\pi a^2 n^2 \mu}{2} \int_{h-l/2}^{h+l/2} \left[\frac{z'+l/2}{\sqrt{a^2 + (z'+l/2)^2}} - \frac{z'-l/2}{\sqrt{a^2 + (z'-l/2)^2}} \right] dz' \quad (13)$$

After evaluating the integral, the expression for the mutual inductance is

$$M_{21} = \frac{\pi a^2 n^2 \mu}{2} \left[\sqrt{a^2 + (h+l)^2} + \sqrt{a^2 + (h-l)^2} - 2\sqrt{a^2 + h^2} \right] \quad (14)$$

The self-inductance of the coils can be obtained simply by setting h equal to zero in our expression for M_{12} :

$$L = \pi a^2 n^2 \mu \left[\sqrt{a^2 + l^2} - a \right] \quad (15)$$

Finally, the voltage transfer function, v_2/v_1 , is given by

$$\frac{v_2}{v_1} = \frac{M_{21}}{L} \quad (16)$$

$$\frac{v_2}{v_1} = \frac{\sqrt{a^2 + (h+l)^2} + \sqrt{a^2 + (h-l)^2} - 2\sqrt{a^2 + h^2}}{2 \left[\sqrt{a^2 + l^2} - a \right]} \quad (17)$$

It can be shown that for large h , the transfer function behavior is given by

$$\frac{v_2}{v_1} \sim 1/h^3 \quad (18)$$

A plot of the expression in Equation 18 is shown in Figure A.3. The distance between the coils is varied from 1.125 inches to 40 inches. Note that at a distance of just 40 inches, the induced voltage has been reduced by almost 100dB.

For the other polarization of interest, where the coils are broadside to each other as shown in Figure A.4, it can be shown that the induced voltage is half that of the endfire case, though the field also decreases as the inverse cube of the distance between the coils.

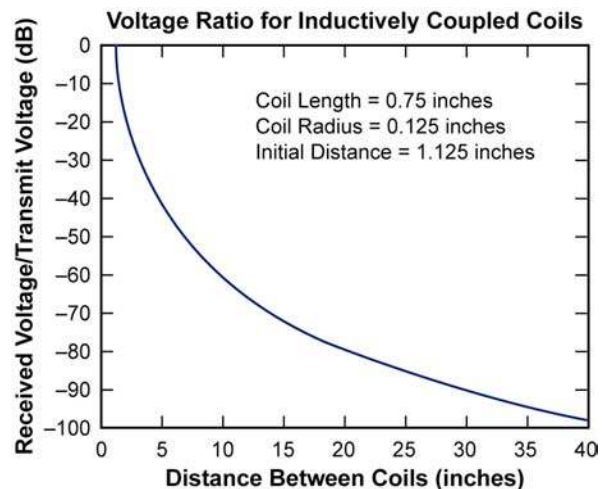

Figure A.3 – Coupling as a function of distance. Coil length 0.75", coil radius 0.125"

A.4. Experimental Verification

To examine the performance of the wireless headset, the base unit was brought into the antenna measurement and its "radiation" characteristics measured. The experimental apparatus is shown in Figure A.5.

A 1kHz tone was input to the base unit to emulate a voice signal and the radiated field was measured using a spiral antenna. The distance of the receive antenna from the base unit was varied and the power level of the received signal was measured using a spectrum analyzer. The experiment results are shown in Figure A.6, overlaid with the theoretical results from Figure A.3. As is evident from the figure, the theoretical curve matches the experimental data extremely well. The sharp drop-off in signal with distance is due to the $1/r^3$ behavior of the magnetic field.

A.5. Discussion

For communication at very short ranges, utilizing coil induction is a simple and inexpensive way to transmit information. The range of the Nasaco unit examined in this memo is about 1.5 meters. As mentioned previously, the very sharp drop-off in signal is due to the $1/r^3$ field behavior. For an electrically small loop antenna in the region very close to the antenna ($kr \ll 1$), the field drops off as $1/r^3$. In the far field, ($kr \gg 1$), the radiated field drops off as $1/r$, as it does for conventional RF communication systems. For our problem $kr \approx 0.05$, for $r = 1.5$ meters, and we are operating in the very near field of the coil. For such electrically small antennas, the radiation resistance is quite small and such antennas tend to be very inefficient. In addition, they tend to be quite difficult to match since the input impedance contains a large reactive component (inductance, in this case).

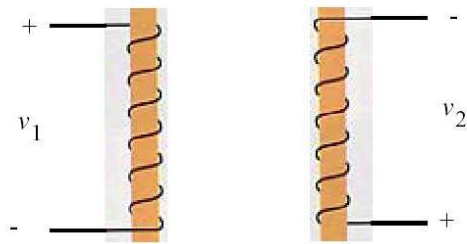

Figure A.4 – Broadside coupling geometry

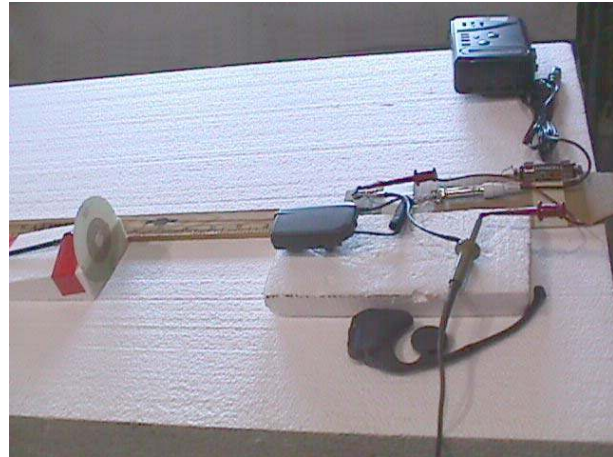

Figure A.5 – Experimental setup for near-field measurement of Nasaco headset

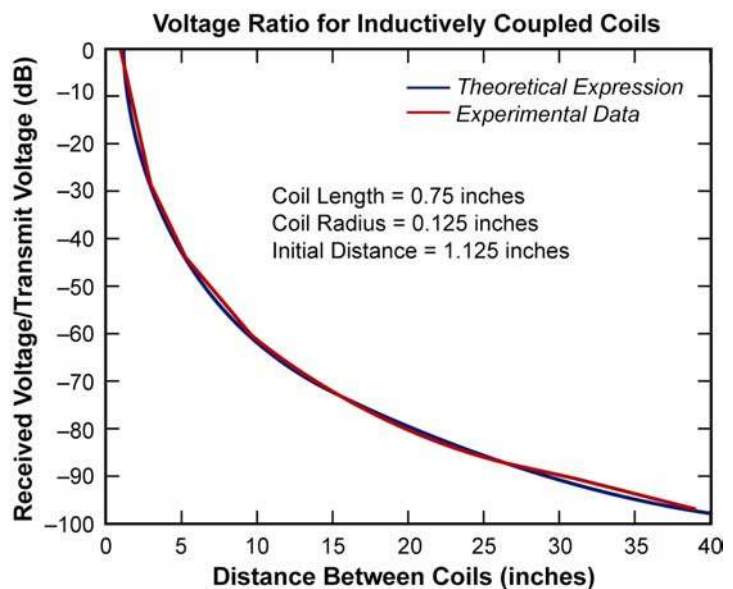

Figure A.6 – Comparison of predicted and measured induced coil voltage

If a communications range of 10-20 meters is desired, it is probably best to go with an electrically larger antenna, requiring a higher carrier frequency. An electrically larger antenna would be easier to match and would be a more efficient radiator.

However, for use in a PAN, where it is desired to minimize interference due to proximity of other users, minimize the RF signature of the user, and minimize susceptibility to jamming, the small, inefficient antenna is a benefit. Furthermore, although the antenna is very inefficient, the overall power efficiency of a free-space magnetic induction system is better than high-frequency RF systems.

Evaluation of Conductive Textiles for Cardiorespiratory Monitoring

B.1. Background

One of the most critical challenges facing combat medicine today is mortality determination. Approximately 25% of all medics who die in combat do so while trying to render aid to deceased soldiers. Commercially available heart and respiration monitoring devices have improved greatly, but they are not suitable for military use due to both lack of ruggedness and anatomical (body movement) constraints. The rigorous and often conflicting set of requirements for military equipment usually mandates the development of novel technologies. Conductive textiles offer a unique combination of chemical, mechanical, and electrical properties that may lead to the development of better bioelectric interfaces for physiological monitoring applications.

B.2. Objective

The goal of this experimental effort was to determine whether a continuous piece of conductive fabric could serve as both bioelectric interface and electrical conductor while still providing the favorable mechanical properties of a textile. The task involved isolating the three conductive electrode sites, securing the fabric to the torso and establishing solid bioelectric contact, and obtaining a usable ECG waveform of a quality suitable for mortality assessment.

B.3. Materials and Methods

A 3" x 12" piece of silverized plain weave nylon fabric (Laird Technologies PC90005J) was etched into three separate conductive regions by immersing the ~1" margins between the to-be-formed electrodes into a dilute solution of hydrochloric acid, sodium chloride, zinc chloride, and a small amount of detergent to improve surface wetting (which, as it turned out, led to excessive wetting and overetching of the left region, as can be seen in Figure B.1. Less detergent was used for the second etch and the delineation was visibly improved). The fabric was connected to a current-limited power supply through a copper clamp assembly and anodically etched at an initial electrolysis current of 100 mA for about five minutes, using a bare copper strip as a counter electrode. The etching was self-limiting and was allowed to proceed to completion. This was repeated for the other region, creating three isolated patches approximately 3" square, as shown in Figure B.1. Isolation was confirmed with a DVM, which indicated patch-to-patch resistances in excess of 20 M Ω . A brief (<1 sec) etch in sodium chloride solution "activated" the silver by creating a thin film of silver chloride. The thin silver-chloride layer in contact with the skin reduces the 1/f noise and prevents electrode polarization during use.

Stranded wire leads were soldered to small copper foil tabs. The tabs were then adhered to the fabric with a conductive contact adhesive (Nickel Print, GC Chemicals). The two outer electrodes were live and the center electrode served as a ground reference, both to shield the wire leads from electrical pickup and to “anchor” the body near ground potential to keep both inputs within the dynamic range of the amplifier. The fabric strip was then secured across the chest using elastic bands and adjusted to optimize the signal. A simple bridge amplifier was used to amplify the signal to ~ 1 Vpp for acquisition and display on a digital oscilloscope (Lecroy 9314A). The data was then lowpass filtered in software to reduce both extraneous noise and aliasing artifacts introduced by the digital sampling process.

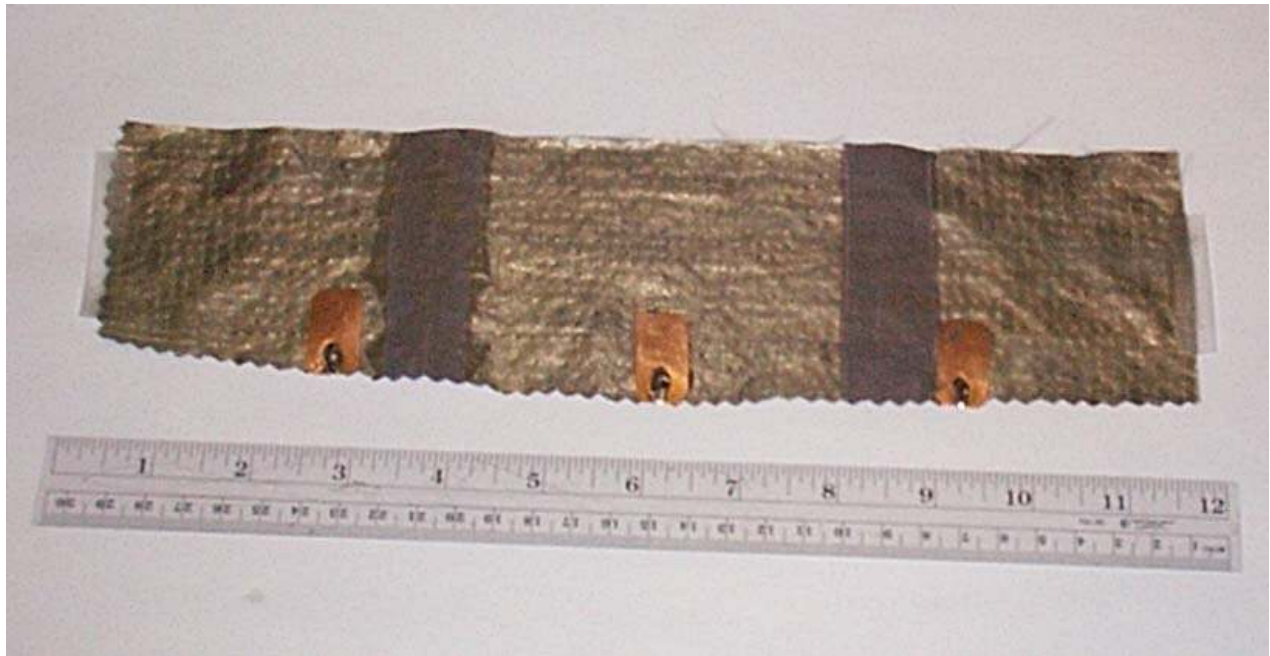

Figure B.1 – The textile electrode assembly. Leads were soldered to the copper foil tabs

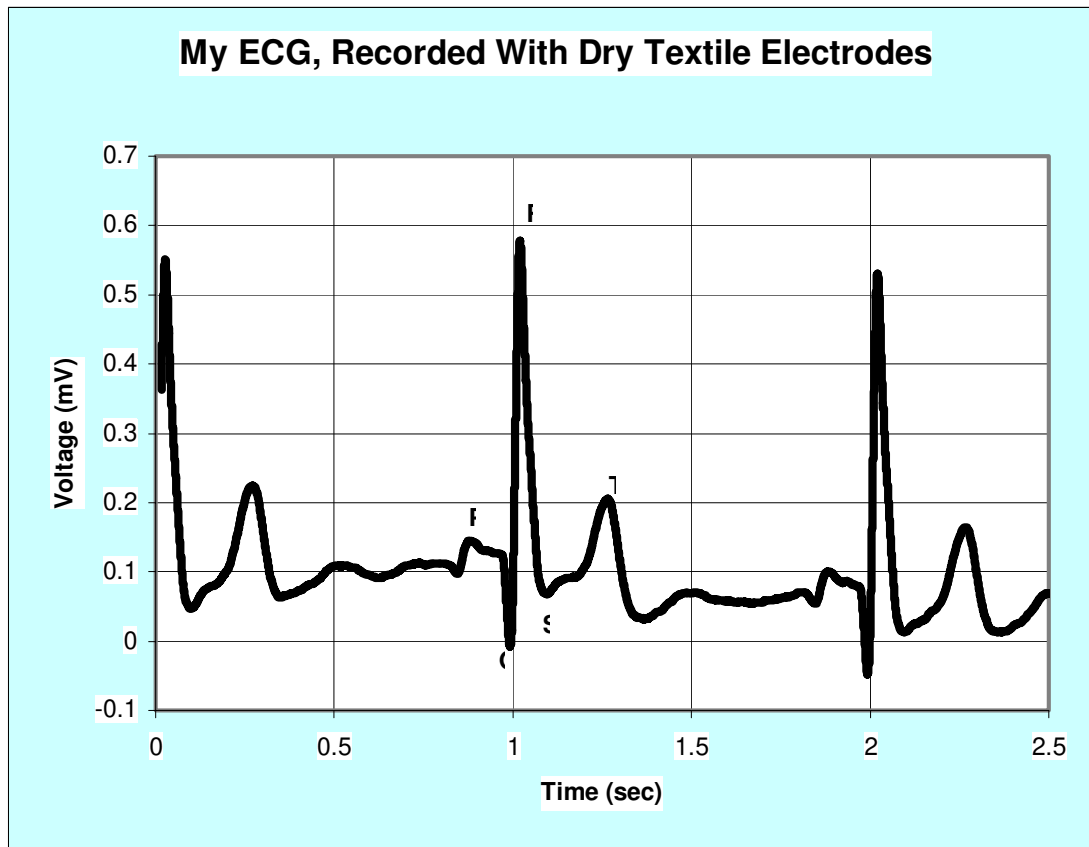

Figure B.2 – A cardiac signal recorded with the textile electrode assembly

B.4. Results

The electrolytic etching process was surprisingly effective. This suggests that multiple electrodes could easily be fashioned within a single undergarment. The voltage stability of the electrode/skin interface improved with time. The cardiac signal shown in Figure B.2 was recorded after about five minutes of electrode/skin contact. Motion artifacts were noted, and appeared to decrease in amplitude with time. An electrode assembly was also fabricated from a piece of stretch knit fabric, but this gave poorer results than the plain weave nylon material. It appeared that the stretching process generated significant motion artifacts that, unlike the plain weave material, did not decrease with time.

B.5. Discussion

This was only conceived as a proof-of-principle experiment, so little effort was spent on optimization and refinement. However the results were promising in that

1. An ECG waveform was successfully recorded
2. The electrode regions were easily isolated
3. The electrode areas were quite small

Although ECG monitoring is very simple to perform, a more effective measurement would involve an active transthoracic conductance measurement. This would permit monitoring of

both cardiac and respiratory functions simultaneously. Since the penetration varies with modulation frequency, it may be possible to tailor the modulation frequency, or employ multiple modulation frequencies, to better isolate both cardiac and respiratory activity. Quadrature excitation would permit simultaneous measurement of both the real (resistive) and imaginary (reactive) components. Since blood is more conductive than tissue, it may even be possible to detect significant changes in blood volume fraction and hematocrit over time. This could be useful in the detection of blood loss and for monitoring hydration status.

B.6. Conclusions

An ECG trace was successfully recorded using conductive fabric electrodes. The active regions were easily isolated through electrochemical etching. The plain weave (non-elastic) nylon material produced better ECG waveforms than did the stretch knit material, presumably due to motion artifacts created during the stretching process. Increasing the surface area of the electrodes should significantly improve the quality of the ECG waveform although this may require the use of a loose-weave stretch knit fabric to maximize comfort in hot, humid environments.

B.7. Suggestions for Future Work

1. Construct a four-electrode version to evaluate the utility of transthoracic impedance cardiorespirometry. Advancements would include multiple frequencies and quadrature detection for true impedance measuring capability.
2. Test a full-size model of an undergarment constructed of conductive fabric. Determine the optimum dimensions and placement for the three (or four) electrodes. Determine whether insulation is needed between the electrode interconnect traces and the skin of the abdomen.
3. Investigate various means of providing electrical connections to the garment. Goals should be simplicity, convenience, and ruggedness.

Related Efforts

C.1. SAILSS (FY00-FY07)

The Smart Aircrew Integrated Life Support System (SAILSS) is USN Future Naval Capability (FNC) as well as a Defense Technical Objective (DTO HS.26) to monitor and modify the physiological state of a pilot in order to regulate and maximize the pilot's ability to perform at optimum levels in adverse environments, particularly high-g, extreme temperatures, and nuclear/biological/chemical situations.

Specific objectives of the program include providing protection against g-forces in excess of 9 Gs, providing an early warning of an altered state of awareness induced by physiological stress. Active control is accomplished by integrating physiological sensors in life-support equipment (e.g., g-suit) and adjusting parameters of the life-support equipment and the aircraft based on bio-feedback.

Physiological sensors are embedded in the helmet, mask, and a sensor vest worn by the aviator. Additional sensors are embedded in the aircraft and the cockpit. The SAILSS system includes a host computer, physiologic sensors, signal-conditioning system, and a VME data acquisition and control computer. Commercially available components are in use for the sensors.

Since pilot range of motion is limited relative to dismounted infantry and the aircraft platform imposes less stringent requirements on allowable weight and power, the hardware implementation may not be relevant to WPSM requirements. However, the algorithms for automated analysis of physiological status are likely areas of common intersection with WPSM.



Figure C.1 – SAILSS sensor and control ensemble

The point of contact for the SAILSS program is Dr. Estrella Forster, NAVAIR, 301-342-9278.

C.2. Smart Healthcare Management System

NASA Ames Research Center in collaboration with the Stanford Biocomputation Department is developing a network architecture for health monitoring on board the space station. The current system employs iPAQ hand-held computers to collect sensor data and transmit the information to other devices or servers through a switchboard. The network technology can be implemented with any standard commercial LAN technology such as 802.11 devices. Any wireless technology available in a Type II PC card, such as Bluetooth, can be used to implement the wireless network.

Stanford has designed an interface to the Nexan sensor patch that collects sensor data directly in the format required by the Smart HealthCare Management Systems (SHMS) network architecture, by-passing the wireless link and Partner PDA.

The following summary description of the program is excerpted from the NASA URL astrobionics.arc.nasa.gov/atd_shms.html.

The SHMS is managed and operated by the AstroBionics Program as a project under the Space Medicine element of the Bioastronautics Division. The SHMS construct functions as a technology agent/advocate, develops prototype and demonstration products, and facilitates their leverage and transition to end-user applications.

The SHMS activity includes the development of a Personal Status Monitoring System and Device that is integrated with a Personal Physiological Monitoring System (PPM), a Personal Environmental Monitoring System (PEM), and a Personal Clinical-Biological Monitoring System (PCM). The SHMS Project is developing wearable/personal Physiological Status & Monitoring Systems (PSM) that contribute in controlling a feedback loop through data management for input in decision assessment for astronauts and crew in space.

The SHMS focuses on development in five thrust areas:

C.2.1. Personal Physiological Monitoring

Advanced, wireless, wearable, ambulatory personal physiological monitoring and signal conditioning system for astronaut crew health status monitoring and telemedicine interfaces will support long-duration crew medical characterization and countermeasures. *In situ* and embedded-process monitoring and control systems will permit optimization of closed-loop and regenerative life-support systems, allowing for demand-oriented, condition-based monitoring and information management.

C.2.2. Personal Clinical/Biological Monitoring

Advanced sensors and technologies for cell and molecular biological applications will allow for real-time, *in situ* clinical, and analytical, laboratory analyses for fundamental biological and medical characterizations, and interventions.

C.2.3. Personal Environmental Sensors and Instruments

Lightweight, attachable, wearable, environmental sensors and arrays will monitor the environmental conditions around the astronaut/subject and will permit operational protocols that will control certain specific environmental attributes around and near the subject.

C.2.4. Instrumentation Platforms

Digital Signal Processing, Scientific Instruments for Closed-Loop Life Support Process Control & Monitoring, Laboratories Testbeds and Applications Resources, *in situ* measurements systems for SHMS and a Personal Area Wireless Network.

C.2.5. Data Management, Interpretation, and Presentation

Project Management and Science and Technology Liaison, documentation, reporting, communications, Wireless Distributed Information Network to analyze the data obtained by the PSM system and allow for application of protocols that will help control through feedback mechanism.

The point of contact for SHMS is Dr. John Hines, NASA/ARC, 650-604-5538, jhines@mail/arc.nasa.gov

References

- [1] B. Shender, "US Navy Acceleration Research Programs," *Acceleration Research News*, Vol. 2, Issue 1, May 2001.
- [2] —, "Smart Aircrew Integrated Life Support System," Defense Technology Objectives for DTAP HS.26, pg. II-304, 2000.
- [3] E. Forster, "Thermal Physiology and Stress on Human Performance," Combat Medicine Conference, London, May 2000.

Processor and Memory Trends

D.1. Moore's Law and Implications

For the past four decades, integrated circuit technology has doubled in performance every 18 to 24 months. This trend was first observed and articulated by Gordon Moore in a now famous speech, and the trend is likely to continue at least until the fielding of Future Force Warrior in 2015.

Moore's Law, which isn't a law at all but has become the mantra of the semiconductor industry, is a double-edged sword for the military. On the one hand, the exponential improvement of integrated circuit technology has been a major factor in enabling the development of the mobile communications and processing that is essential to the realization of FFW. On the other hand, since integrated circuit technology that powers mobile computing and communication doubles in performance every two years, fielding military systems with technology that is only a few years old is sufficient to ensure the systems will be obsolete relative to commercial products and capabilities. Even if the military is willing to use older equipment, the rapid obsolescence of commercial systems makes long-term maintenance costly because replacement ICs and electronic modules often have a very short production life.

It is essential, therefore, that military systems be specified and designed to incorporate commercial standards and technology wherever possible in order to enable cost-effective upgrades in the future.

D.2. Performance Metrics

In the speech in which Gordon Moore made the observation that integrated circuit technology appeared to be doubling in performance every 18 to 24 months, his performance metric was essentially the number of transistors in an integrated circuit. For FFW and its precursors, the import of Moore's law is how it will affect system performance. The primary system parameters of interest are

1. Energy cost of information processing and storage
2. Maximum processing speed and memory access speed
3. Maximum storage capacity

D.3. Energy Cost of Processing and Storage

Although the semiconductor industry has managed to fulfill Moore's prediction of exponentially increasing circuit density, power dissipation has been increasing rather than decreasing. The fundamental relationship defining power dissipation in a CMOS gate is

$$P \propto fCV^2 .$$

The power dissipated is proportional to the product of switching frequency, f , gate capacitance, C , and the square of the operating voltage, V . Shrinking feature sizes of ICs have driven gate capacitance down, but this is somewhat offset by increased clock frequencies. Operating voltages have also decreased to yield lower power per gate, but the exponential increase in gates per IC has resulted in a slow rate of power reduction at the chip level. As a consequence, overall power dissipation in the Intel class of microprocessors has risen with increasing complexity and performance. Power-efficient processors are being developed, with digital signal processors (DSP) receiving the greatest attention. The progress in producing low-power DSP chips is indicated in Figure D.1, where the improvement in power normalized by instruction rate (energy per instruction) shows an improvement factor of 10X in 2.5 years. Notice that since 1993, reducing power supply voltage has contributed significantly to efficiency, but the limits of voltage reduction are being reached in current devices, and additional improvements in power efficiency will require shutting down unused circuitry or moving algorithms in to semicustom or custom hardware to realize greater efficiency in the use of instruction cycles.

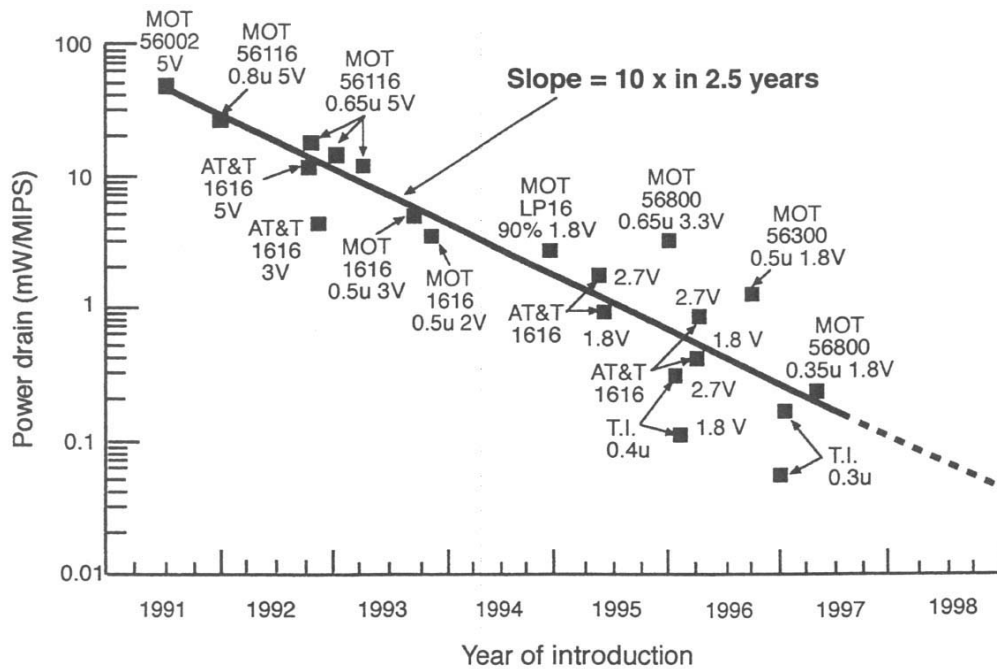

Figure D.1 – Evolution of power dissipation in DSP chips normalized by instruction rate

In general, custom, or semicustom processing implementations can easily realize a factor of 100x or better improvement in energy per instruction. Therefore, for the purpose of estimating energy requirements for processing, programmable processors currently require on the order of 1 nJ/instruction and custom processors on the order of 10 pJ/instruction.

Execution of an algorithm with 1 million instructions would therefore require approximately 0.01 to 1mJ. For high-energy density batteries, a joule of energy can be stored in a volume of 1 mm³, weighing about 1.4 mg. Of course, if the algorithm is executed many times per second on a continuous basis, the energy costs can become significant. For example, decompression of video imagery requires on the order of 10⁷ operations per frame, so an hour of full rate video requires about 1.5 grams of battery equivalent to a volume of about 1 cm³.

D.4. Processing Speed

Processor clock rates have increased at a rate somewhat lower than the rate of feature shrinkage. As shown in Figure D.2, the average clock rate increase for the Intel family of microprocessors is about one order of magnitude increase per decade of time since 1978. Assuming this rate of improvement persists through 2010, processor clock speeds will be in excess of 10 GHz, enabling billions of operations per second (provided they are not all memory accesses). Alternately, processor clock rates could be slowed or made programmable to realize greater energy savings.

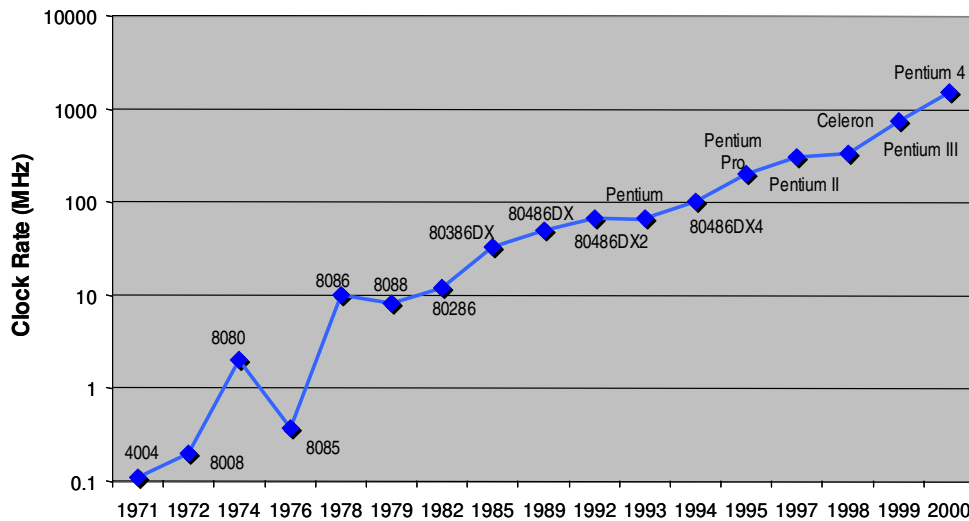

Figure D.2 – Clock speed for Intel family of processors

Current processor speeds and future predicted speeds are certainly adequate to consider implementing sophisticated processing of sensor data on the soldier for purposes of feature extraction, analysis, and compression of information. As algorithms mature, firmware implementations can be used to further enhance the power-speed product.

D.5. Storage Capacity

The important memory performance parameters are energy storage cost and access speed. The most reliable performance parameter to predict, assuming the continued validity of Moore’s Law, is the memory density per chip.

D.5.1. Density

For a fixed chip area, Moore’s Law implies that the density of memory will double approximately every 18-24 months, and this trend is confirmed in the memory density curve of Figure D.3. Projecting ahead to 2015, a single memory chip could conceivably contain as much as 500 GB of storage, and memory for mobile computing will therefore be specified in

terabytes (TB) rather than the megabytes of today. To grasp the significance of this much memory, note that if we allocated 50 bytes of storage to hold the name, address, and some ancillary information for every person on Earth, this would all fit into one memory chip. The implication is that storage of GIS data and other types of reference information for missions will not be a problem.

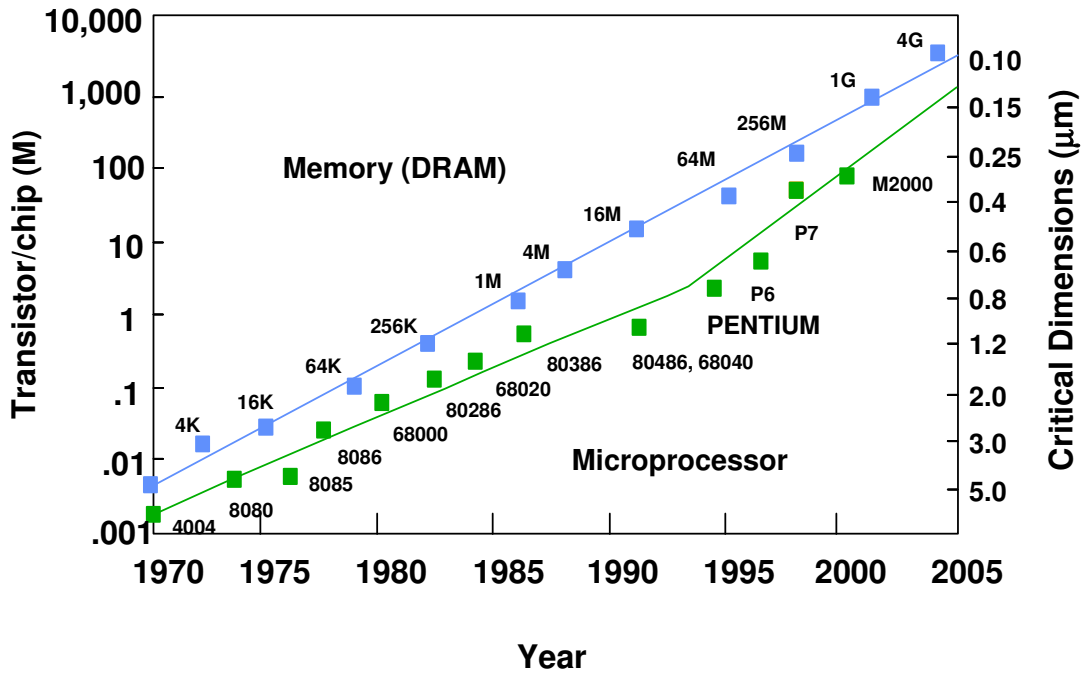

Figure D.3 – Trends in memory and processor circuit density

Detecting Hypovolemia Through Retinal Vasculometry

E.1. Introduction

Currently there is no simple means of quantifying the degree of blood loss in battlefield casualties or accident victims. Casualties who normally exhibit overt signs of reduced blood volume, such as rapid heart rate, faintness, and hyperventilation, would normally be treated promptly. During battle however, tachycardia and tachypnea may be misattributed to autonomic arousal resulting from enemy engagement.

Casualties with slow internal bleeding may exhibit normal vital signs despite the loss of as much as half of their blood volume. Since their vital signs may appear close to normal, they would typically be triaged as “delayed” or “minimal.” This ability of the body to compensate for slow bleeding is especially true for young healthy individuals who serve in our combat forces. The danger is that these patients can rapidly progress from an apparently normal state to severe vascular collapse with little or no warning. At this point even vigorous volume-replacement therapy can be ineffective, and the result can be multiple-organ failure, leading to serious morbidity or death.

This new technique may provide a simple and noninvasive means of determining whether trauma victims and casualties suffering from internal or external blood loss are at risk for hypovolemic shock. Circulating blood volume is estimated from imagery easily obtained through transpupillary measurement of the retinal vasculature.

E.2. Technical Description

Blood volume measurement through retinal vasculometry is based upon the hypothesis that the body maintains a delicate balance between the circulating blood volume and the volume within the vascular system. This is necessary to provide sufficient venous return to feed the hydraulic demand of the heart. Since the heart has evolved to operate as a positive-pressure pump, it requires a steady supply of venous blood. In order to maintain this supply, the body employs a number of physiologic feedback loops to both maintain adequate circulating blood volume and to match the vascular volume to this blood volume, thus maintaining adequate venous return. Vascular volume is related to vascular diameter through a simple square-law relationship (assuming a cylindrical vessel model).

We believe that the best location to monitor vascular diameter noninvasively is from within the eye. Optical measurements of the retinal vasculature offer a number of advantages over other vascular measurement techniques:

1. The circulation within the eye is governed by the same cerebral autoregulatory mechanisms as the brain itself. Thus, retinal perfusion tracks cerebral perfusion.
2. The retina is located deep within the skull and follows the temperature of the cerebral cortex quite closely. This provides a significant degree of immunity to environmental conditions or states of arousal, which normally affect peripheral vascular tone, such as heat, cold, physical exertion, fear, etc.
3. The transparency and refractive properties of the eye make it ideal for performing optical measurements of the retina. This allows for noncontact sensing, which offers numerous advantages over invasive sensing techniques.
4. The intraocular pressure is slightly greater than ambient, which should provide an enhancement of the vasoconstriction seen in the venous vasculature within the eye.
5. Retinal vasculometry can be performed with inexpensive and rugged equipment adapted from designs used for biometrics or ophthalmic use.

Figure E.1 shows the commercial digital fundus camera used to collect the imagery shown below.

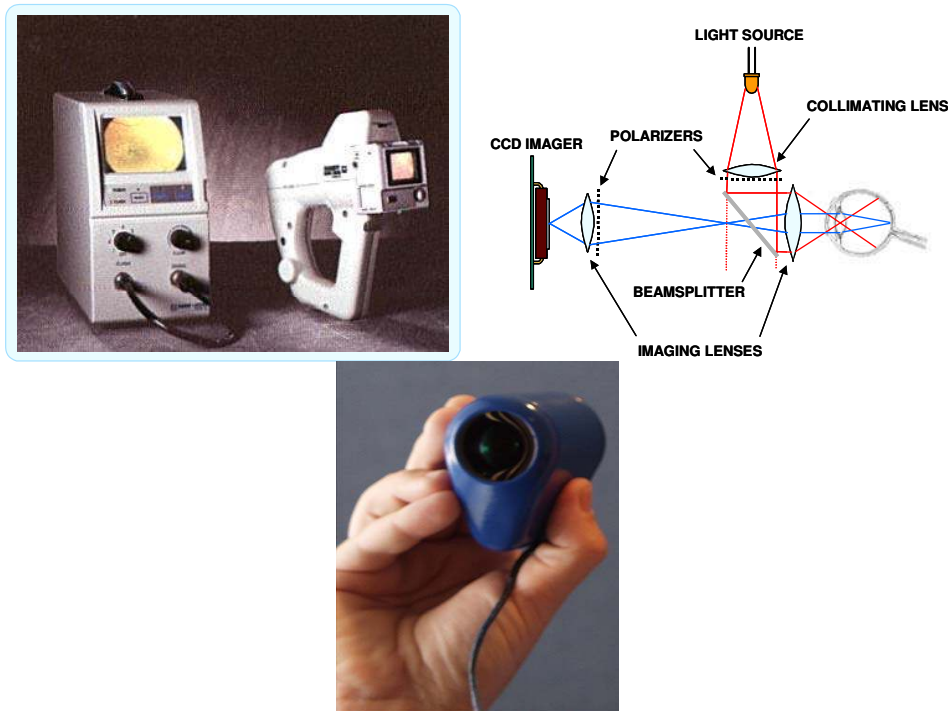

Figure E.1 – The Nidek NM100D digital fundus camera and a simplified optical diagram of the handpiece. This FDA-approved device was used to collect 640 x 480 color images of both rodent and human retinal vasculature. Future implementations could employ far simpler and more compact retinal imagers, like the handheld unit shown to the right (courtesy of Retinal Technologies)

The vessels were measured and identified using a free software package (The GIMP, Ver. 1.2). The method by which vessel diameters were obtained is depicted in Figure E.2.

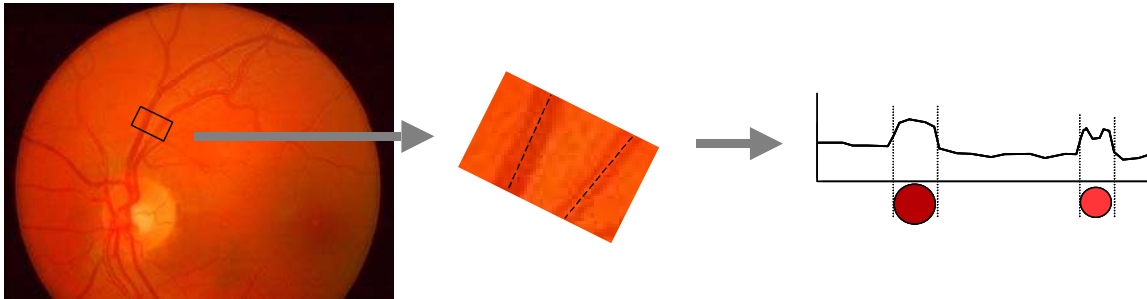

Figure E.2 – The raw retinal imagery was examined to locate vascular structures visible in both the baseline and post-bleed images. These image regions were then imported into an image processing software package, and linear pixel amplitude scans were used to determine vascular diameter as the FWHM value of the vascular signal change. Arteries were discriminated from veins by their distinct spectral and reflectance differences (desaturated venous blood is darker, while arterial walls are thicker and thus produce a greater specular glint)

E.3. Rodent Measurements

Preliminary measurements in rodents showed a clearly observable correlation between blood volume and vessel diameter, as shown in Figure E.3.

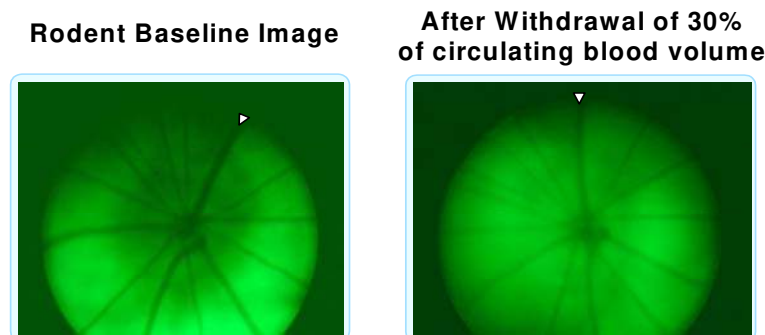

Figure E.3. Retinal imagery from a 300g HSD rat both before and after the gradual withdrawal of ~30% of the circulating blood volume through tail vein incision. Only the “G” channel of the RGB images are shown, since they provided the best image contrast between the blood-filled vessels and the unpigmented retinal tissue. The white arrows serve as fiducial markers. Changes in both image contrast and vessel diameter are visible, with larger vessels exhibiting the greatest change.

The results presented in Figure E.4 demonstrate that vessel diameter is only minimally affected by blood pressure within the cerebral autoregulatory range, which for rodents ranges from about 50 mmHg to 150 mmHg.

	Baseline	-5.0cc	-7.0cc
Blood Loss	0%	-26%	-36%
Blood Pressure	97mm	65mm	60mm
Arterial Dia.	---	-11%	-32%
Venous Dia.	---	-13%	-23%
All Vessels	---	-12%	-25%

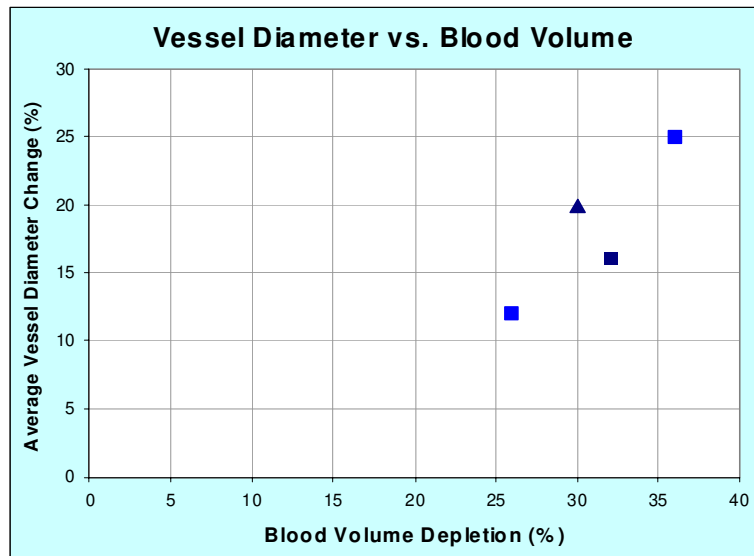

Figure E.4 – The results of Trial #2 (light blue squares) show that although the mean arterial blood pressure decreases following the first blood withdrawal, a subsequent withdrawal caused only a slight reduction in mean arterial pressure but a sizeable reduction in vessel diameter. This supports the notion that retinal vessel diameter is only minimally affected by blood pressure changes within the cerebral autoregulatory range. The results of all three trials reveal a direct relationship between blood loss and retinal vessel diameter

E.4. Future Human Measurements

Retinal measurements from instrumented human volunteers undergoing simulated hypovolemic episodes will provide data of much higher quality which can then be analyzed in a more quantitative fashion. This will permit the development and evaluation of quantitative blood volume estimation algorithms. Hypovolemia can be induced in humans with a high degree of safety using a lower-body negative pressure (LBNP) chamber. A typical LBNP chamber is shown in Figure E.5.



LBNP Chamber

Figure E.5 – An LBNP chamber used to study the cerebral hemodynamic response to posturally simulated microgravity, as experienced during spaceflight

LBNP causes excess blood to pool in the lower extremities by overcoming the normal venous vasomotor tone with modest levels of vacuum. By varying the vacuum level, a continuum of hypovolemic symptoms can be produced, ranging from mild tachycardia to profound syncope. If an adverse reaction were to occur, normal circulation could be restored in a matter of less than a minute by returning the lower extremity pressure to normal.

E.5. Algorithm Development

An algorithm is required to convert the raw retinal vascular imagery into quantitative measure of circulating blood volume. The following candidate algorithms are being considered:

E.5.1. Differential Composite and Ratiometric Vascular Comparison

Baseline normovolemic retinal measurements would be taken prior to a high-risk mission and stored in the instrument or in a readily retrievable form (a flash memory drive, for example) kept by each individual. Following a suspected hemorrhagic injury, new retinal measurements would be recorded and compared to the previously stored measurements, and the differences in vascular diameter would then be used to estimate the degree of blood loss. A *composite* vascular comparison would treat arteries and veins collectively. A *ratiometric* vascular measurement would quantify veins and arteries separately. It is likely that measuring both venous and arterial diameter changes will provide more information than a composite vascular measurement, and this may provide a more accurate blood volume estimation.

This is likely to be the most accurate and reliable algorithm, since the normal vascular variability between subjects is removed through subtraction of the baseline images and even

small vessel diameter changes would become readily apparent. The price for this level of accuracy is the need for the collection and storage of baseline imagery from each individual. Although given the availability of inexpensive and reliable data storage media and the simplicity of collecting baseline images, this may not present a problem.

E.5.2. Single-Shot Blood Loss Measurement through Vascular Comparison to Retinal Fiducial Features

Following injury, optical measurements of both the retinal vasculature and of other fiducial features (i.e., structures within the optic disk, the location of the fovea, etc.) would be recorded and used to directly estimate circulating blood volume without the use of prior normovolemic measurements. Variation in vessel areal density and nonuniformities in the cross-sectional diameter of individual vessels were observed to change as a function of blood volume in rodents, and the presence of these features in human LBNP subjects will permit them to be used as the means of estimating blood volume.

Subsequent retinal measurements could then be analyzed using the differential methods described above to provide an accurate measure of any subsequent blood-volume changes.

E.5.3. Concerns

It is thought that confounds may result from variations in $p\text{CO}_2$ and plasma lactate concentration since hypercapnia and metabolic acidosis are both known to influence myovascular tone. However, it is unknown whether such effects would act as confounds or simply appear as coexisting vasoactive influences secondary to compensated shock, and thus have no effect on the accuracy of the measurement. It is likely that the magnitude of these influences will be revealed through human LBNP measurements.

Other concerns include the effects of preexisting retinopathy and possible problems in achieving adequate spatial resolution as a result of uncorrectable ocular distortions. Since this technique was developed for use on young healthy military personnel, and such medical conditions are extremely unlikely in this population, these were not felt to present a problem. However, its use on civilians, specifically those with known ocular or retinal health problems, will require a better understanding of these issues.

E.6. Conclusions

Data from rodent measurements suggests that circulating blood volume can be quantified through optical measurement of the retinal vasculature. If successful, retinal vasculometric blood volume measurement would permit the development of a rugged, portable, easily operated diagnostic tool that could quantify blood volume in seconds, painlessly, with no contact to the patient. Thus, many patients could be “scanned” quickly and easily. This would result in rapid detection and treatment of patients at risk for vascular collapse, potentially leading to a significant reduction in both morbidity and mortality.

E.7. References

- [1] A. M. Siegel, “Measuring circulating blood volume through retinal vasculometry,” MIT Lincoln Laboratory, patent pending, US patent application number 20040064057.

WPSM Draft Requirements

Moore's Law and Implications WARFIGHTER PHYSIOLOGICAL STATUS MONITOR (WPSM)

11th DRAFT PERFORMANCE REQUIREMENT SPECIFICATIONS

1. Operational Concept. The WPSM will provide health and performance status data to commanders at various levels and the battalion medical staff providing support to troops using the LWS. It will provide Commanders with summary data about the capability status of their troops and allow optimization of their physical performance through appropriate interventions. The WPSM will also enable the combat medic to make better decisions regarding the early identification, location, and triage priority of casualties and lead to reduced morbidity and mortality by speeding medical response.
2. Type of System proposed. WPSM will be an integrated suite of physiological sensors and decision support software. The suite will be developed with an "open architecture" consistent with the Department of Defense Joint Technical Architecture. This will allow for time-phased development and insertion of intended capabilities and for the addition/modification of capabilities as new requirements are identified or new solutions to existing requirements are developed. The objective sensor system must be acceptable to the soldier and convenient to use. These characteristics will help with soldier compliance and minimize the expenditure of command energies to enforce monitoring requirements.
3. The WPSM sensors will continuously monitor physiological parameters, but only transmit the minimum essential data to the LW computer for processing, storage, and passage within the LWS. Data processing on the LW computer must be kept to the absolute minimum in order to ensure that sufficient bandwidth and CPU capacity are available for the transmission and processing of mission-essential data. The WPSM sensors will have a self-test function that confirms ongoing data sampling and allows for error checking.
4. Data will be presented in two formats: (1) abnormal raw vital-signs data that will be stored in the medic and BAS computers and (2) interpretative data that has been processed from physiological and physical data inputs into the indicative categories of amber (increased risk of decreased performance) and red (high risk or actual decreased performance). The measured threshold parameters will be automatically calibrated by the WPSM to an individual's normal physiological baseline. Interpretative data will flow to commanders primarily, but the squad medic and BAS will also receive this data. Data within the ranges deemed normal for an individual would not be transmitted or processed unless the relevant commander, medic, or BAS activates a formal requirement.

5. The WPSM system must allow for the collection and exchange of data with Special Operations Forces, US Marines, and Allied Forces. All software used by WPSM will be DII COE compliant and have the ability to transfer data into the TMIP databases.
6. General Characteristics. The WPSM will provide the following capabilities: [Initial (I) Pre-Planned Product Improvement (P³I)]
 - a. Ease of Use. The WPSM will not diminish the mobility of the wearer and will not interfere with the wearer in performing any mission task. The system will be acceptable to the user and allow for maximal compliance that can be monitored by the command chain. The system will be non-irritating and require minimal input from the wearer.
 - b. Weight. The total weight of the WPSM (including sensors and any processors) will be less than one pound (I), 10 ounces (P³I).
 - c. Wireless Data Transmission. The WPSM sensors will transmit data to the LW computer in a wireless manner and be compatible with the LW computer (I), and ultimately integrated with the LW Personal Wireless Network (P³I).
 - d. FDA Approval. The WPSM systems will comply with all applicable FDA standards.
7. Remote Triage. This will be a manual process initially utilizing the available physiological data (I) but will be automated in the future, allowing the relative priority of multiple casualties to be determined automatically (P³I). The WPSM will send an auto alert to the platoon medic, squad leader, and platoon sergeant when a casualty requires immediate treatment to prevent a wounded-in-action (WIA) casualty from degrading or possibility progressing to killed-in-action (KIA). The combat medic will have the ability to spot-check each soldier with a query. The sensor suite data will allow the combat medic to determine if the soldier is alive or dead and allow for the optimum priority for triage and evacuation of multiple casualties. This system will provide data sufficient to determine the likelihood of adverse outcomes in the following situations:
 - a. Determination of alive /dead status (I)
 - b. Hemorrhagic shock (I)
 - c. Respiratory distress/function (I)
 - d. Neurological function (P³I)
8. Force Health Protection monitoring. The WPSM will monitor physiological and performance status parameters to provide a Commander with data about the general condition of his troops. This will allow him to optimize the physical capabilities of his troops through appropriate interventions, thus increasing his chances of mission success. The following parameters will be measured:
 - a. Thermal Stress Risks. Early determination of heat and cold stress risk will allow interventions to reduce the likelihood of thermal injury. The risk index should provide an estimate of the likelihood of an individual becoming a thermal casualty within a 2-hour period. (I)
 - b. Hydration State. The knowledge of a soldier's hydration state will allow the accurate assessment of an individual's fluid requirements and assess the risk of cognitive and physical performance decrement. The mean percentage

- dehydration of an individual will be estimated to a standard deviation of 1% dehydration. (P³I)
- c. Sleep Status. This capability will measure the number of hours of sleep a soldier has had in the preceding 48–72 hours. Predetermined thresholds will trigger an amber or red alert. This will allow commanders to monitor a soldier's sleep levels and actively manage sleep/rest cycles in order to improve performance. (I)
 - d. Mental Alertness Status. This capability will provide risk estimates for lapses in complex mental functioning (e.g., impaired decision-making, reduced vigilance, situational awareness). Risk estimates must also be generated for the performance of key military tasks (e.g., shooting, navigation, target recognition). Measures of mental alertness will provide a broad indicator of psychological functioning. This will allow the Commander to assess the soldier's cognitive readiness and performance capability for these tasks in the operational environment. (P³I)
 - e. Metabolic Status/Energy Reserve. This capability will estimate metabolic status related to acute energy deficit and predict changes in body energy stores. The initial capability will estimate a soldier's daily energy balance based on activity and estimated ration schedules. Amber and red triggers will occur when there is an increased risk of significant impairment in physical (I) and mental (P³I) performance.
 - f. Altitude Adaptation: This capability will determine an individual's response to the stress of altitude. Amber and red triggers will occur when an individual displays predetermined signs of impending altitude sickness. (P³I)
 - g. Chemical/Biological Agent Exposure. This capability will assess a combination of physiological parameters to calculate the likelihood of having been exposed to a chemical or biological agent. Determination of adverse changes in biochemical and physiological parameters will alert commanders that there is a significant risk of adverse chem-bio exposures. (P³I)
 - h. Wounding Alert. This capability will trigger an alarm when the soldier sustains a penetrating or blunt wound. (P³I) The location of the wound will also be determined at a gross level. (P³I) The combat medic will use this information to provide advice to the appropriate small-unit leader who will determine the appropriate action. The sensor must be able to predict the likely outcome of a wounding event with 99 percent accuracy.
9. Data exchange capability. The WPSM will be capable of transmitting raw and sensor processed data into the soldier's computer and to the medic, BAS, squad, platoon, company, and battalion commander. The WPSM communicates via the LWS computer, which uses joint variable message formats (JVME) via FBCB2 to convey information. Software that can transmit the WPSM data within the LWS is required and must not interfere with JVME data transmission. When the WPSM sends out an alert, it will begin recording specified data on the medic's computer hard drive. This physiological data record must be subsequently transferred to the medic's MC4 / TMIP device and recorded onto the patient's Electronic Information Carrier (EIC) prior to evacuation. The WPSM will also respond to queries from the squad leader, platoon sergeant, and company first sergeant, as well as the combat medic and the battalion medical staff.

10. Decision Support. The data from the sensor suite will be processed to produce meaningful information for commanders and battalion medical staff. The raw data must be transformed into simple condition risk states of amber and red. These condition states will provide the Commander and the medical staff with a real-time risk assessment of performance degradation. More detailed analysis of the raw data to resolve borderline risk states may be required by the battalion medical staff. Aggregated data will provide unit summaries of soldier status.
11. In addition to the WPSM, Land Warrior has a soldier Emergency Assistance (911-call) device to allow an injured soldier to request assistance and include a triage priority. The activation point of this device should be accessible, enabling rapid and simple initiation, as well as the ability to turn it off. This point should have protection from inadvertent activation and must allow activation by the soldier's "buddy." Security to prevent activation by the enemy must also be included. This call will go to the platoon medic, platoon sergeant, battalion aid station and the chaplain.
12. WPSM information will flow as follows;
 - a. To the combat medic and squad leader: when the soldier has been wounded or when sensor suite exceeds predetermined parameters
 - b. To the platoon and company commander: when the predicted risk of performance decrement reaches a level predetermined by the commander
 - c. To the battalion commander: when previously established command interest parameters are exceeded. This will allow the Battalion commander to tailor the information he receives
 - d. To unit surgeon: all data received by the Battalion Commander as well as the raw data. This will enable the staff to advise the commander on its significance
 - e. To the battalion chaplain: in the event of a 911 call, a positive alert for wounding or death
 - f. To the individual soldier: specific alerts may be received by the soldier at the commander's discretion, e.g., hydration status. At the completion of the mission, the soldier should have the capability to review all of his WPSM amber and red alerts
13. Examples in which information could be used directly at the squad or company level, with only secondary links to the combat medic, include management of thermal stress, sleep/alert status, and hydration state. The software suite will notify the company commander whenever the WPSM of a squad leader, platoon sergeant, or other key person in the unit exceeds defined parameters. The unit surgeon will be notified when the commander's parameters exceed the normal range.

Technology Readiness Levels

G.1. Background

Technology Readiness Levels (TRL) is a system employed by NASA to grade the maturity of technology beginning with 6.1-6.2 research and evolving toward operational capability. The DoD recognized the need to develop a similar technology maturity taxonomy and MPMC is in the process of developing TRL definitions for medical systems. A working set of definitions, still in draft form is included below

G.2. TRL Definitions and Acceptance Thresholds

TRL Level & NASA Description	NASA Definition	Medical Devices	Knowledge Products	Medical Informatics
TRL 1: Basic principles observed and reported.	Lowest level of technology readiness. Scientific research beings to be translated into technology's basic properties.	Scientific literature reviews and initial Market Surveys are initiated and assessed. Potential scientific application to defined problems is articulated.	Scientific literature reviews and initial Market Surveys are initiated and assessed. Potential scientific application to defined problems is articulated.	Identification of the potential medical solution to mission need. Medical informatics data and knowledge representation issues are defined.
TRL 2: Technology concept and/or application formulated.	Invention begins. Once basic principles are observed, practical applications can be invented. The application is speculative and there is not proof or detailed analysis to support the assumption. Examples are still limited to paper studies.	Hypothesis(es) is generated. Research plans and/or protocols are develop, peer reviewed, and approved.	Hypothesis(es) is(are) generated. Research plans and/or protocols are develop, peer reviewed, and approved.	Medical Informatics and data and knowledge representation schema are defined.
TRL 3: Analytical and experimental critical function and/or characteristic proof-of-concept.	Active research and development is initiated. This includes analytical studies and laboratory studies to physically validate analytical predictions of separate elements of the technology. Examples include components that are not yet integrated or representative.	Initial proof-of-concept for device candidates is demonstrated in a limited number of laboratory models (may include animal studies).	Identification of key technology barriers and methodologies and a defined plan of research including specific critical hypotheses.	Medical Informatics data and knowledge representation schema are modeled.

<p>TRL 4: Component and/or breadboard validation in laboratory environment.</p>	<p>Basic technological components are integrated to establish that the pieces will work together. This is relatively "low fidelity" compared to the eventual system. Examples include integration of <i>ad hoc</i> hardware in a laboratory.</p>	<p>Proof-of-concept demonstrated for candidate devices/systems and laboratory/animal models defined. Initial device master record completed.</p>	<p>Proof-of-concept demonstrated for knowledgware candidates, experimental models, and methodologies defined.</p>	<p>Medical Informatics data and knowledge representation models are instantiated with representative data or knowledge from applicable domain.</p>
<p>TRL 5: Component and/or breadboard validation in a relevant environment.</p>	<p>Fidelity of breadboard technology increases significantly. The basic technological components are integrated with reasonably realistic supporting elements so that the technology can be tested in a simulated environment. Examples include "high fidelity" laboratory integration of components.</p>	<p>IDE submitted to and reviewed by CDRH to determine if clinical trials may proceed.</p>	<p>Effectiveness of knowledgware candidates demonstrated in a high-fidelity laboratory or simulated operational environment. Knowledgware technology development plan reviewed and approved.</p>	<p>Medical Informatics data and knowledge representation models are implemented as data and/or knowledge management systems and tested in a lab environment.</p>
<p>TRL 6: System/subsystem model or prototype demonstration in a relevant environment.</p>	<p>Representative model or prototype system, which is well beyond the breadboard tested for TRL 5, is tested in a relevant environment. Represents a major step up in a technology's demonstrated readiness. Examples include testing a prototype in a high fidelity laboratory environment or in simulated operational environment.</p>	<p>Data from Phase 1 trials meet clinical safety requirements and support proceeding to Phase 2 clinical studies.</p>	<p>Effectiveness of product supported by controlled studies (in humans or appropriate surrogate models) designed to provide statistical significance. Validation protocols designed to test prototypes in actual operational environment with humans or validated surrogate models are approved.</p>	<p>Medical Informatics data and knowledge management systems are tested with target applications in a lab environment. Configuration management developed.</p>

<p>TRL 7: System prototype demonstration in an operational environment.</p>	<p>Prototype near or at planned operational system. Represents a major step up from TRL 6, requiring the demonstration of an actual system prototype in an operational environment, such as in an aircraft, vehicle, or space. Examples include testing the prototype in a test bed aircraft.</p>	<p>Phase 2 clinical effectiveness and safety trials completed. Final product design validated, and final prototypes and/or initial commercial scale devices are produced. Data collected, presented, and discussed with CDRH at Pre-Phase 3 meetings; supports continued device development. Clinical endpoints and test plans agreed to by CDRH. Phase 3 clinical study plan has been approved.</p>	<p>Small-scale validation trials successfully completed. Data collected validate the fully integrated prototype(s) and support proceeding to full-scale validation trials.</p>	<p>Medical Informatics data and knowledge management systems are operationally integrated and tested with target applications in an operational environment.</p>
<p>TRL 8: Actual system completed and "flight qualified" through test and demonstration.</p>	<p>Technology has been proven to work in its final form and under expected conditions. In almost all cases, this TRL represents the end of true system development. Examples include developmental test and evaluation of the system in its intended weapon system to determine if it meets design specifications.</p>	<p>Approval of the PMA [or, as applicable, 510k] for devices by the CDRH.</p>	<p>External review approval equivalent to that required for ANSI or ANSI-like standard is obtained.</p>	<p>Developmental test and evaluation of the HW/SW system in its intended environment demonstrate it meets design specifications. Fully integrated and operational Medical Informatics data and knowledge management systems are validated in several operational environments.</p>
<p>TRL 9: Actual system "flight proven" through successful mission operations.</p>	<p>Actual application of the technology in its final form and under mission conditions, such as those encountered in operational test and evaluation. In almost all cases, this is the end of the last "bug fixing" aspects of true system development. Examples include using the system under operational mission conditions.</p>	<p>None – continue surveillance.</p>	<p>Final acceptance of knowledgeware product by user.</p>	<p>Product successfully used during military mission as component of IOT&E phase. Logistical demonstration successfully conducted.</p>

G.3. Software-Specific TRL Definitions

Technology Readiness Level	Description
1. Functionality conjectural.	Lowest level of software readiness. Basic research begins to be translated into applied research and development. Examples might include a concept that can be implemented in software or analytic studies of an algorithm's basic properties.
2. Technology concept and/or application formulated.	Invention begins. Once basic principles are observed, practical applications can be invented. Applications are speculative and there is no proof or detailed analysis to support the assumptions. Examples are limited to analytic studies.
3. Analytical and experimental critical functions and/or characteristic proof of concept.	Active research and development is initiated. This includes analytical studies to produce code that validates analytical predictions of separate software elements. Examples include software components that are not yet integrated or representative but satisfy an operational need. Algorithms run on a surrogate processor in a laboratory environment.
4. Functionality demonstrated in a laboratory environment.	Basic software components are integrated to establish that they will work together. They are relatively primitive with regard to efficiency and reliability compared to the eventual system. System software architecture development initiated to include interoperability, reliability, maintainability, extensibility, scalability, and security issues. Software integrated with simulated current /legacy elements as appropriate.
5. Functionality and performance demonstrated in a relevant environment.	Reliability of software ensemble increases significantly. The basic software components are integrated with reasonably realistic supporting elements so that it can be tested in a simulated environment. Examples include "high fidelity" laboratory integration of software components. System software architecture established. Algorithms run on a processor(s) with characteristics expected in the operational environment. Software releases are "Alpha" versions and configuration control initiated. Verification, Validation and Accreditation (VV&A) initiated.
6. Functionality and performance demonstrated in a realistic simulated (live/virtual) operational environment.	Representative model or prototype system, which is well beyond that of TRL 5, is tested in a relevant environment. Represents a major step up in software-demonstrated readiness. Examples include testing a prototype in a live/virtual experiment or in simulated operational environment. Algorithm run on processor or operational environment integrated with actual external entities. Software releases are "Beta" versions and configuration controlled. Software support structure in development. VV&A in process.
7. Functionality and performance demonstrated in an operational test environment.	Represents a major step up from TRL 6, requiring the demonstration of an actual system prototype in an operational environment, such as in a command post or air/ground vehicle. Algorithms run on processor of the operational environment integrated with actual external entities. Software support structure in place. Software releases are in distinct versions. Frequency and severity of software deficiencies reports do not significantly degrade functionality or performance. VV&A completed.
8. Functionality, performance and quality attributes* validated in an operational.	Software has been demonstrated to work in its final form and under expected conditions. In most cases, this TRL represents the end of system development. Examples include test and evaluation of the software in its intended system to determine if it meets design specifications. Software releases are production versions and configuration controlled, in a secure environment. Software deficiencies are rapidly resolved through support structure.
9. Functionality, performance and quality attributes* proven in an operational environment through successive successful accomplishment of mission operations.	Actual application of the software in its final form and under mission conditions, such as those encountered in operational test and evaluation. In almost all cases, this is the end of the last "bug fixing" aspects of system development. Examples include using the system under operational mission conditions. Software releases are production versions and configuration controlled. Frequency and severity of software deficiencies are at a minimum.

*Quality attributes include reliability, maintainability, extensibility, scalability, and security

Acronym Definitions

ARL	Army Research Laboratory
BAS	Battalion aid station
BIA	Broad industry announcement
BIDS	Ballistic impact detection system
C ⁴ I	Command, Control, Communications, Computers and Intelligence
CDMA	Code division multiple access
CECOM	Communications Electronics Command
CEO	Chief executive officer
CMOS	Complimentary metal oxide semiconductor
COE	Common operating environment
Conops	Concept of operations
COP	Common operating picture
COTS	Commercial off-the-shelf
CPU	Central processing unit
DPI	Dots per inch
DSP	Digital signal processing
DTO	Defense technology objective
ECG	Electrocardiogram
EEG	Electroencephalogram
EIRP	Effective isotropic radiated power
EMI	Electromagnetic interference
FBCB2	Force XXI Battle Command Battalion/Brigade and Below
FCC	Federal Communications Commission
FCS	Future combat system
FDA	Federal Drug Administration
FFW	Future force warrior
FNC	Future naval capability
FPGA	Field programmable gate array
FSK	Frequency shift keying
GIS	Geographical information systems
GPS	Global positioning system
Hazmats	Hazardous materials
IC	Integrated circuit
IEEE	Institute of Electrical and Electronic Engineers
IOC	Initial operational capability
IPA	Integrated protection analysis
IR	Infrared
IrDA	Infrared data association
IrLAP	IrDA link access protocol
ISM	Instrumentation, Scientific, and Medical band
JVME	Joint variable message format
KIA	Killed in action
LBNP	Lower-body negative pressure

LCD	Liquid crystal display
LED	Light emitting diode
Linux	Linus Torvald's UNIX
LOS	Line of sight
LW	Land Warrior
LWS	Land Warrior system
MEMS	Micro electromechanical system
MIPS	Millions of instructions per second
MOTS	Military off-the-shelf
MRE	Meal ready to eat
MRMC	Medical Research and Materiel Command
NASA	National Aeronautic and Space Administration
NAVAIR	Naval Air
NLOS	Non-line-of-sight
NRE	Non-recurring engineering
QRS	Principal deflection in the electrocardiogram
PAN	Personal area network
PCM	Personal clinical-biological monitoring
PEM	Personal environmental monitoring
PPM	Personal physiological monitoring
PSM	Physiological status & monitoring
PIC	Personal information chip
PDA	Personal data assistant
P ³ I	Pre-planned product improvements
RDECOM	Research, Development and Engineering Command
RF	Radio frequency
RFID	Radio frequency identification
SAILSS	Smart aircrew integrated life support system
SHMS	Smart healthcare management system,
SNR	Signal-to-noise ratio
SSC	Soldier Systems Center
SVGA	Super video graphics adapter
TEDS	Transducer electronics datasheet
TRL	Technology readiness level
USARIEM	United States Army Research Institute of Environmental Medicine
USB	Universal serial bus
USN	United States Navy
UWB	Ultra wideband
VCSEL	Vertical cavity surface emitting laser
VV&A	Verification, validation & accreditation
VME	Versa module Europe
WPAN	Wireless personal area network
WRAIR	Walter Reed Army Institute of Research
WPSM	Warfighter physiological status monitoring

REPORT DOCUMENTATION PAGE

Form Approved
OMB No. 0704-0188

Public reporting burden for this collection of information is estimated to average 1 hour per response, including the time for reviewing instructions, searching existing data sources, gathering and maintaining the data needed, and completing and reviewing this collection of information. Send comments regarding this burden estimate or any other aspect of this collection of information, including suggestions for reducing this burden to Department of Defense, Washington Headquarters Services, Directorate for Information Operations and Reports (0704-0188), 1215 Jefferson Davis Highway, Suite 1204, Arlington, VA 22202-4302. Respondents should be aware that notwithstanding any other provision of law, no person shall be subject to any penalty for failing to comply with a collection of information if it does not display a currently valid OMB control number. **PLEASE DO NOT RETURN YOUR FORM TO THE ABOVE ADDRESS.**

1. REPORT DATE (DD-MM-YYYY) 1 November 2004			2. REPORT TYPE Final Report		3. DATES COVERED (From - To)	
4. TITLE AND SUBTITLE Warfighter Physiological and Environmental Monitoring: A Study for the U.S. Army Research Institute in Environmental Medicine and the Soldier Systems Center					5a. CONTRACT NUMBER F19628-00-C-0002	
					5b. GRANT NUMBER	
					5c. PROGRAM ELEMENT NUMBER	
6. AUTHOR(S) G.A. Shaw, A.M. Siegel, G. Zogbi, and T.P. Opar					5d. PROJECT NUMBER	
					5e. TASK NUMBER	
					5f. WORK UNIT NUMBER	
7. PERFORMING ORGANIZATION NAME(S) AND ADDRESS(ES) MIT Lincoln Laboratory 244 Wood Street Lexington, MA 02420-9108					8. PERFORMING ORGANIZATION REPORT NUMBER	
9. SPONSORING / MONITORING AGENCY NAME(S) AND ADDRESS(ES) U.S. Army Medical Research & Materiel Command 504 Scott Street Ft. Detrick, MD 21702-5012					10. SPONSOR/MONITOR'S ACRONYM(S) U.S. Army Soldier Systems Center Kansas Street Natick, MA 01760	
					11. SPONSOR/MONITOR'S REPORT NUMBER(S) ESC-TR-2004-077	
12. DISTRIBUTION / AVAILABILITY STATEMENT Approved for public release; distribution is unlimited.						
13. SUPPLEMENTARY NOTES						
14. ABSTRACT An unprecedented opportunity exists to introduce real-time physiological and environmental monitoring technology into future US Army dismounted forces for use in both training and combat situations. The motivation is to enhance the survivability of the individual warfighter and to provide increased situational awareness to both combat medics and commanders during the course of a mission or field operation. The monitoring technology must be reliable, must be unobtrusive, and compelling in terms of value to both the lowest-echelon warfighters and their command chain. Realizing these objectives will require adapting and extending ambulatory medical monitoring technology well beyond the capabilities of current commercial devices and systems, and will place the US Army in a unique position with regard to real-time physiological status and health monitoring. This report identifies specific technology and system level issues that must be addressed to realize the objective system and proposes both a near-term and far-term system concept and development strategy. Technology developments critical to success include covert wireless personal area networking, physiological and environmental sensors hardened for the dynamic warfighter environment, and real-time data processing and fusion algorithms to extract the relevant physiological information and overall health status.						
15. SUBJECT TERMS Physiological monitoring, personal area network, hypovolemia, ambulatory monitoring, environmental monitoring						
16. SECURITY CLASSIFICATION OF:			17. LIMITATION OF ABSTRACT Same as report	18. NUMBER OF PAGES 126	19a. NAME OF RESPONSIBLE PERSON	
a. REPORT Unclassified	b. ABSTRACT Unclassified	c. THIS PAGE Unclassified			19b. TELEPHONE NUMBER (include area code)	