

WAVE FORCES ON THE EIDER EVACUATION SLUICES

J. DIETZ and G. VAN STAAL*

Bundesanstalt für Wasserbau, Karlsruhe, Germany

*former eng. Delft Hydraulics Laboratory

SUMMARY

For a safe and efficient dimensioning of the Eider Evacuation Sluices it was necessary to know the magnitude and probability of the occurring wave forces.

To determine those data a model investigation has been carried out in one of the wind flumes of the Delft Hydraulics Laboratory in charge of and in co-operation with the Bundesanstalt für Wasserbau in Karlsruhe.

For this purpose it was necessary to consider all combinations of wave conditions and waterlevels in nature which can lead to important wave forces, taking into account their probability of occurrence. It was on these grounds that the conditions for the model tests were chosen.

The results of the model investigation had to be translated into probabilities of exceedance of the wave forces per year.

Taking into account the results of the model tests as well as the general knowledge about the distribution of the wave forces, suitable load figures have been determined especially for the dimensioning of the structure. Only this extensive investigation could provide the guarantee of a safe and efficient dimensioning of the structure against the impacts of breaking waves.

1. INTRODUCTION

The improvement of the water-levels and the conditions for the navigation in the Eider, which is threatened by a regularly continuing sedimentation, as well as the safety at stormflood conditions and the protection of the coast make it necessary to dam up the tidal Eider on the West coast of Schleswig-Holstein (Figure 1).

The projected damming-up consists essentially of a dike with a length of about 4 km, to give safety against storm-floods and of a complex of evacuation sluices with five openings, each with a span of 40 m. These evacuation sluices will be generally open, so that stream caused by the tide can pass freely.

Only at storm-flood the sluice complex will become an enclosure structure, if the gates are closed in time.

The sluice complex is to be built of reinforced concrete, and because the ground which has sufficient ability to bear is only found at rather great depth, the structure will be founded on piles.

To give double safety, two segment gates are used in each opening, each fixed to a tensioned concrete bridge with a span of 40 m (Figure 2).

Because of the function of the evacuation sluices and their situation being strongly exposed to waves from the open sea, the possibility has to be reckoned with that with high wind velocities breaking waves can attack the sluices through the existing channel or through a channel which will possibly be built in the mouth of the Eider. For this reason the construction will have to withstand not only quasihydrostatic forces, which have a progress in time corresponding to the wave period, but also very high wave impacts.

2. MODEL TESTS

For a secure and efficient dimensioning of the evacuation sluices, it was necessary to know the magnitude and the accessory probability distribution of the occurring

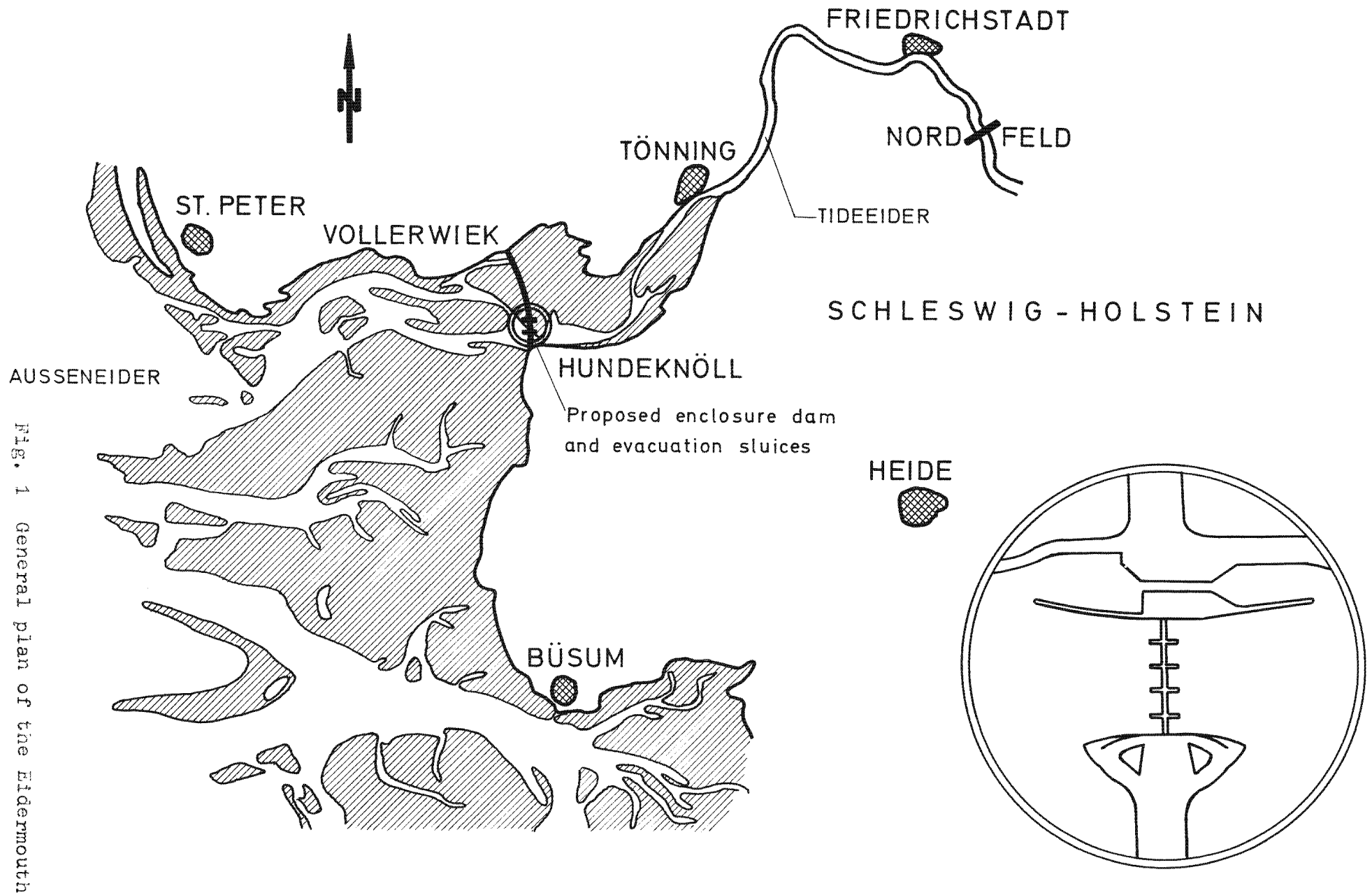
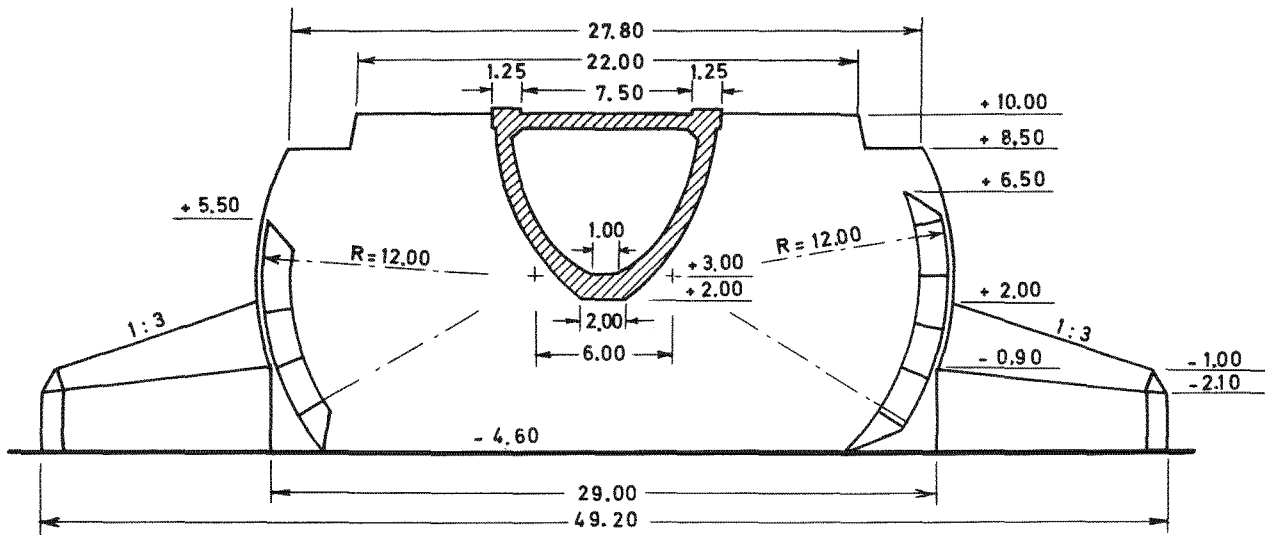

Fig. 1 General plan of the Eidermouth



Dimensions related to prototype (m).
All heights are related to NN

Fig. 2 Cross-section of the evacuation sluices

wave impacts. This has been determined by model tests (Ref. 6). The wave impacts do not depend only on the shape of the structure and the bottom configuration in front of it, but also and in an important way, on the specific characteristics of the waves, including the breaker phenomena.

Because it is possible to imitate these phenomena very well by wind-generated waves, the model investigation has been carried out in the wind flume of the Laboratory "De Voorst" Section of the "Delft Hydraulics Laboratory". The investigation was commissioned by the Bundesanstalt für Wasserbau in Karlsruhe and has been made in close co-operation between the Bundesanstalt für Wasserbau and the Delft Hydraulics Laboratory.

For the determining of the programme of the model tests, which were carried out on a scale 1 : 25, it was taken into account that it is important for the dimensioning of both the segment gates and the tensioned concrete bridge, including the supports, to know both the local wave impacts and the sum forces which occur at the same time on different parts of the

structure. In connection with this, different situations of loading have to be distinguished:

- A = Outer gate closed
- Wm = Concrete bridge when outer gate has been closed
- Im = Inner gate, when outer gate has been closed
- Wo = Concrete bridge, when outer gate is omitted
- Io = Inner gate, when outer gate is omitted

It is possible that the outer gate will be missing such as when it will be taken out for repair. In this case, the waves will directly attack the concrete bridge and attack the inner gate.

The situation that the outer gate has been left can be kept out of consideration, because it will always be possible to close this gate by its own weight.

The loads were determined by the use of pressure cells, by which for practical reasons at most the signals of five pressure cells, along with the overall sum or the sum of a number of cells were recorded. The sum force which acts on the total surface of a segment gate or the concrete bridge was determined with the help of two measurements which were carried out separately. During one of them the pressure cells were placed in a horizontal position and during the other one in a vertical position. The method will be further described later on.

The pressures in the model were measured on a light-beam recorder. The paper velocity was relatively low, so that it was only possible to determine the magnitude and the number of the wave impacts for all pressure cells, but no idea was obtained about the time-pressure history. For this reason it was decided that for important cases the pressures were also recorded on tape. This made it possible to reproduce these impacts in more detail.

Because of the curved shape of both the segment gates and the concrete bridge, the slope of the front face of the concerned part of the structure at water-level depends on the water-level. For this reason the water-level was chosen as a

variable.

To determine the way by which the wave impacts are influenced by the dimensions of the waves, at each combination of situation and water-level two different wave spectra were tested. This gave the possibility to interpolate and extrapolate to other wave-heights if necessary.

For all relevant combinations of situation, water-level and wave characteristics the pressures were measured in the vertical in the middle of the structure and in the horizontal. For the horizontal the level was chosen at which the greatest wave impacts occurred during the measurements in the vertical.

To obtain data on the pressures near the corner for important cases also measurements were made in the vicinity of piles.

The magnitudes of the wave impacts measured show a very irregular character, as could be expected in view of other tests carried out in the past. For this reason the results at each measuring point were reproduced in terms of probability distributions, related to the number of the applied waves, for all combinations of situation, water-level and wave characteristics tested. This led to about 400 different curves.

****** To obtain a better knowledge of these probability distributions, especially for small probabilities, a test of long duration was carried out for one of the combinations of the conditions measured. The results of these test, for which a duration of more than 10,000 waves was chosen, are shown in a compressed shape in Figure 3.

From the results of this test the following conclusion can be drawn:

1. From the comparison of the results of the tests with 500 and 10,000 waves, and with the latter also separated into groups of 500 - 1,000 - 2,500 - 5,000 and 10,000 waves, it appeared that the scatter in the magnitude of wave impacts decreases according to as they grow in number.
2. The scatter of the greatest wave impacts of a group is rather great as has been found also by other investigators. (Ref.3)

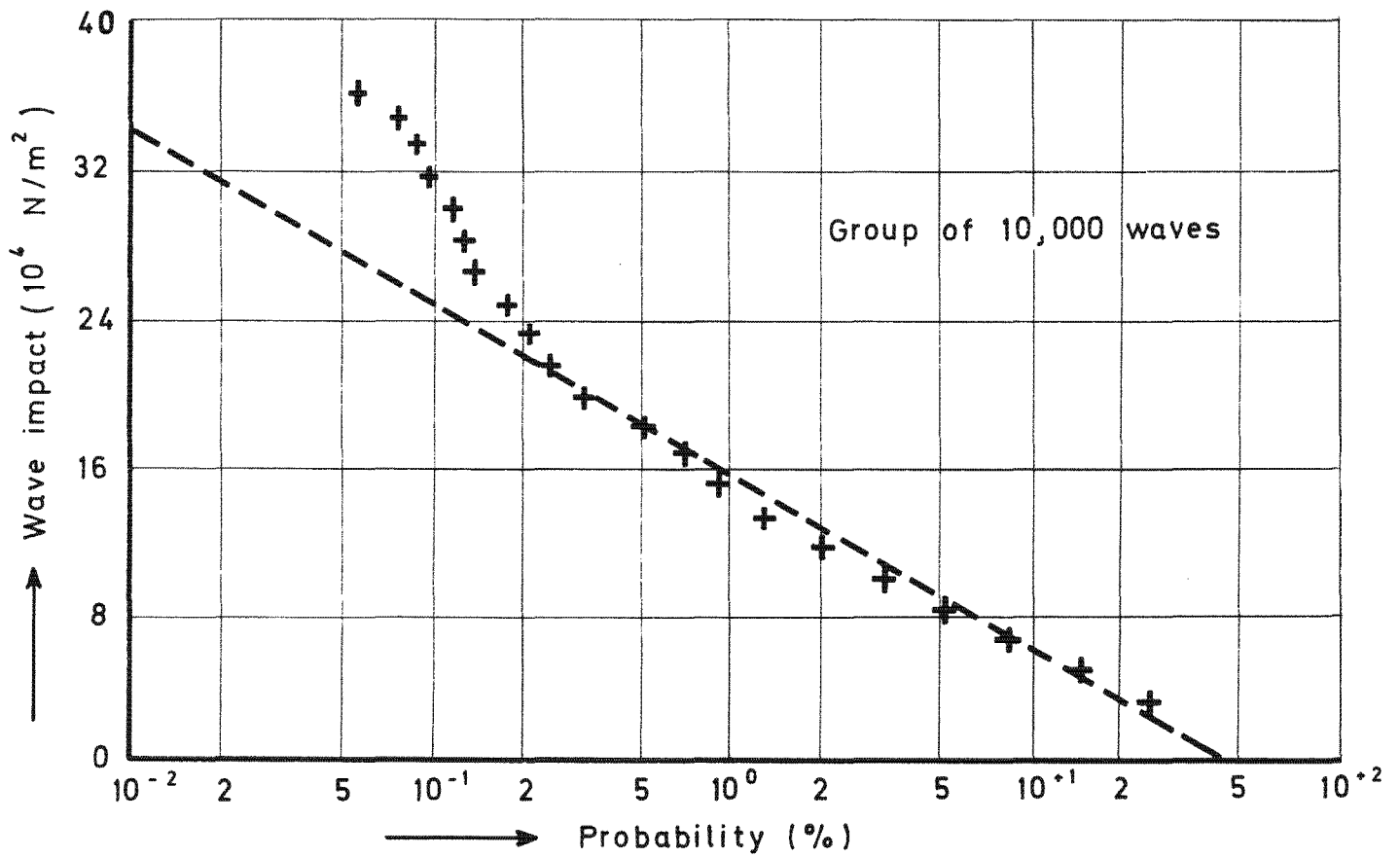
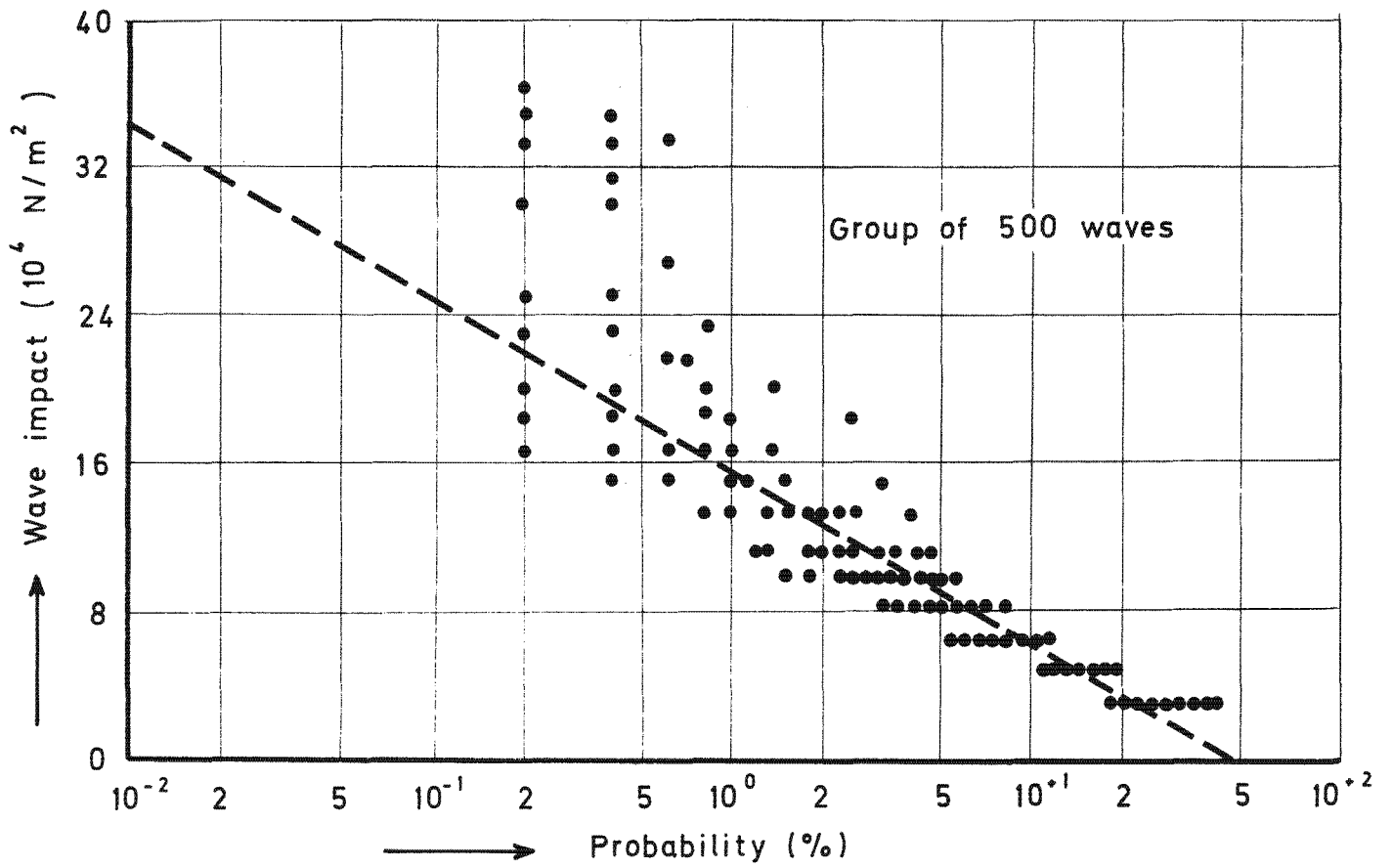

** Fig. 3 Relation between the wave impacts and their propability, related to the number of waves

Based on the results, a logarithmic relation between the impact and the accessory percentage of exceedings was established. According to this relation, all the necessary extrapolations to numbers of more than 500 or 1,000 waves were carried out.

* A point of contact for the difficulties about the
**extrapolation can be found in literature.

As already explained from the model results both the design local pressure and the design sum force had to be determined.

The maximum local pressure is defined as the greatest impact, and this one occurs often about at the average water-level or something above.

The sum force is obtained from the mean value of the impacts occurring on the total surface of the segment gates or the concrete bridge at the same time. This was determined from the probability distribution curves of the measurements in the horizontal and in the vertical. The method which has been used was as follows:

The separate notations can become clear from Figure 4 and the list of symbols.

The sumload can be written as

$$P(x) = l \cdot n^1 \cdot \frac{\bar{P}_h(x)}{P^+(x)} \cdot \bar{P}_v(x) \quad (1)$$

Herein $\frac{\bar{P}_h(x)}{P^+(x)}$ is called α , which is a distribution factor (2).

The factor α being smaller than unity shows that the wave impacts which occur in the vertical do not necessarily occur at the same time over the whole span of the gate. This leads to a three dimensional result of the investigation.

From the tests it has been found that the factor α varies considerably with the shape of the structure. This can be seen from an example shown in Figure 5. Attention has been paid also to the variability of the factor α with the percentage of exceedance of the waves. This factor increases when the

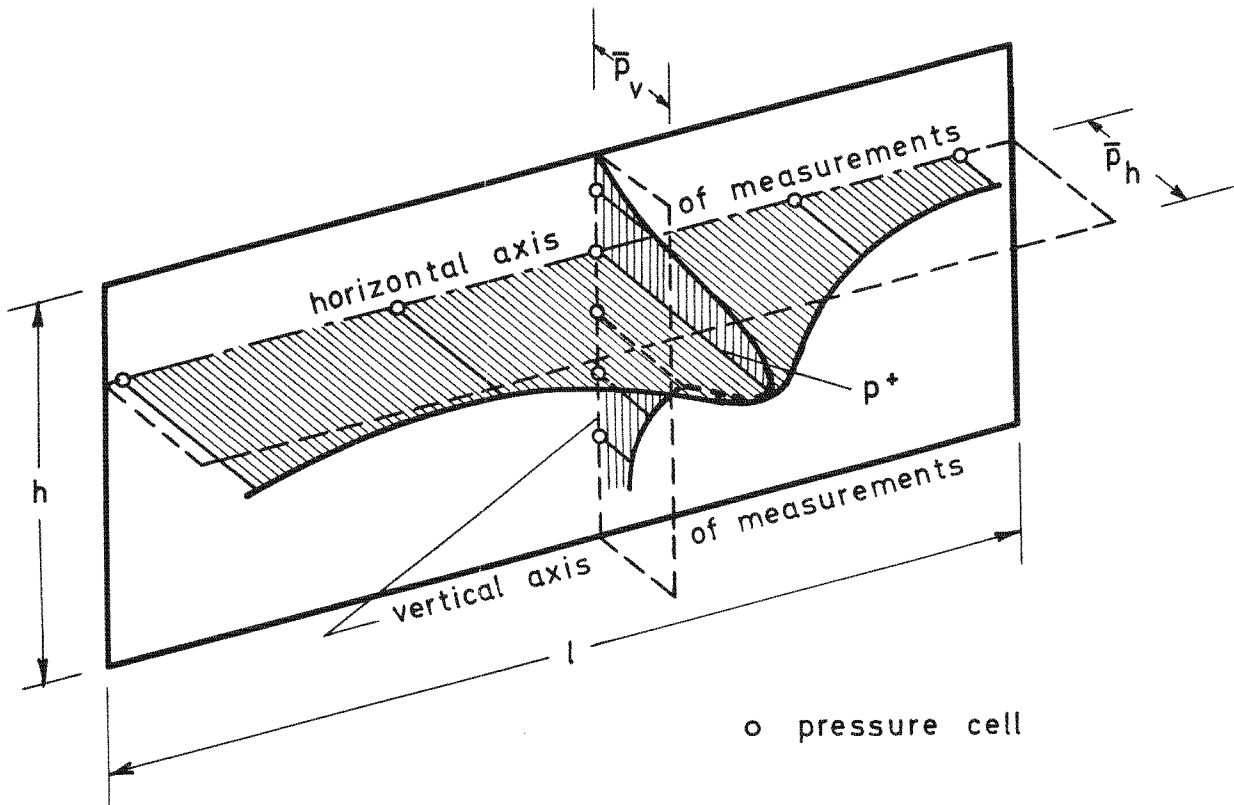

Fig. 4 Example of the three-dimensional view on the load distribution over the surfaces

percentage of exceedance increases.

It reaches theoretically the value 1 if the wave crests are precisely parallel to the front of the structure in which case the same pressure occur along the whole gate or bridge at the same time.

From the model tests for the outer gate it was found furtheron that the factor α increases when the water-level is decreasing. The reason for this can probably be found in the curved shape of the outer gate.

3. CALCULATION OF PROBABILITIES

For the dimensioning of the evacuation sluices and the bridge the starting-point has to be that the structure must resist the wave forces which occur with a chosen probability. To meet this requirement, it was necessary to make a calculation of probabilities.

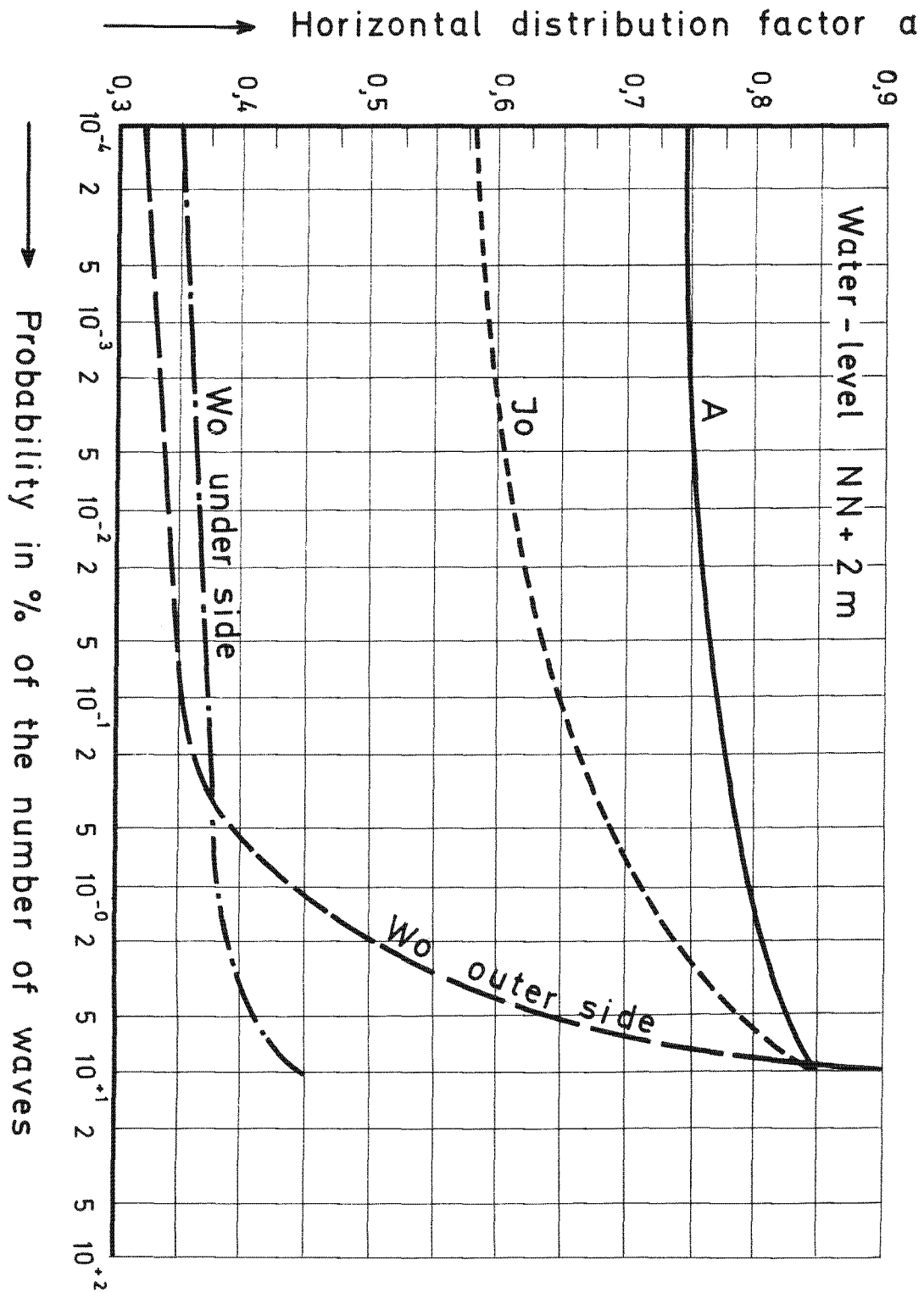

Fig. 5 Examples of the horizontal distribution factor

In this a probability distribution of the pressures was determined, taking into account for each situation both the probability of exceeding of the pressures at fixed wave spectra and the probabilities of the different occurring combinations of water-level and wave characteristics for the concerned situations. These are caused by the tide and the velocity, the direction and the duration of the wind.

For this purpose prototype measurements were available but the short time during which these measurements have been carried out made it necessary to extrapolate the prototype data to the small probabilities required.

****** The probability distribution of the water-level is shown in Figure 6. This has been determined by measurements at the tide gauge at Tønning carried out from 1951 upto and including 1960. The short measuring period also made it necessary to extrapolate as the water-level with a probability of 10^{-3} per year is needed. This extrapolation is facilitated somewhat by the high water of 1962, with a probability of exceedingance of about 10^{-2} per year.

With respect to the probability distribution of the wind velocities from a westerly direction which determine the wave ******forces, only few prototype data were available (Figure 7), so that it was necessary to estimate more or less the probability distribution needed for an extrapolation to 10^{-3} per year.

A valuable control was obtained from the following considerations.

A relation is know between the high water-levels, occurring for the wind direction west, and their probability of exceed. A relation between the high water-level and the wind velocity was wanted for the wind direction west, which can be representative also for the directions W.S.W. and W.N.W. If the last relation can be found the water-level can be eliminated from the two relations, so that the probability curve of the wind velocities is obtained.

For the prototype data on the relation between the high water-level and the wind velocity measurements at Tønning were available.

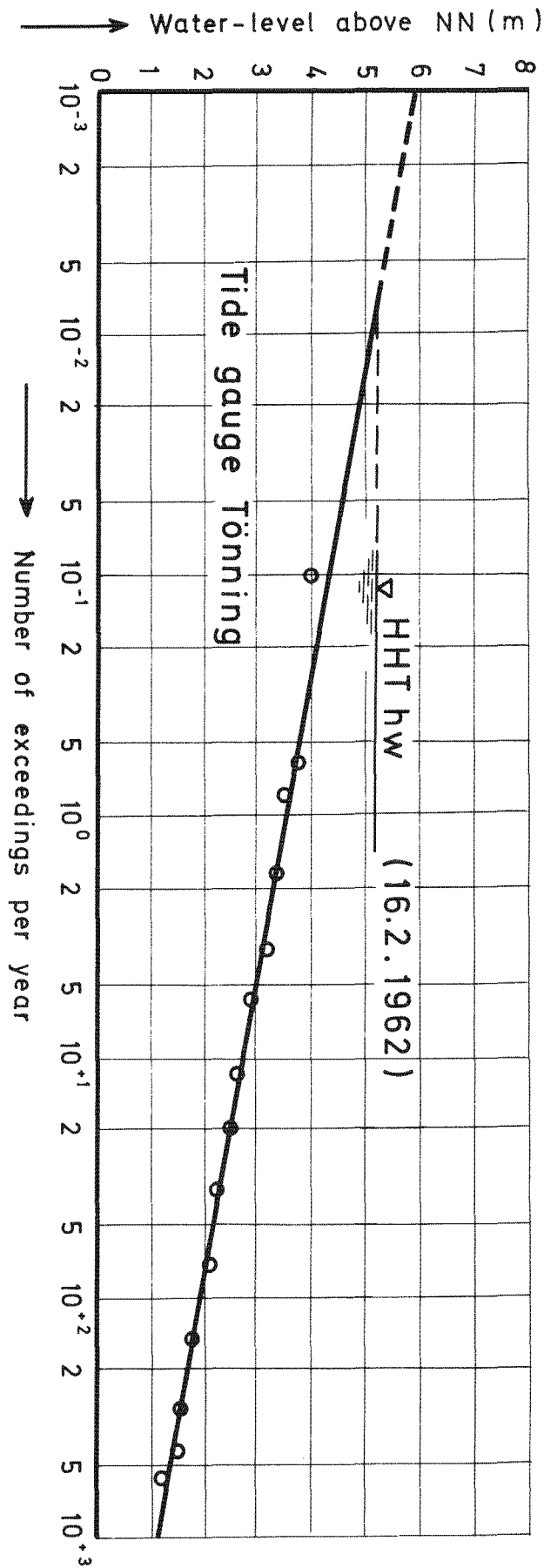
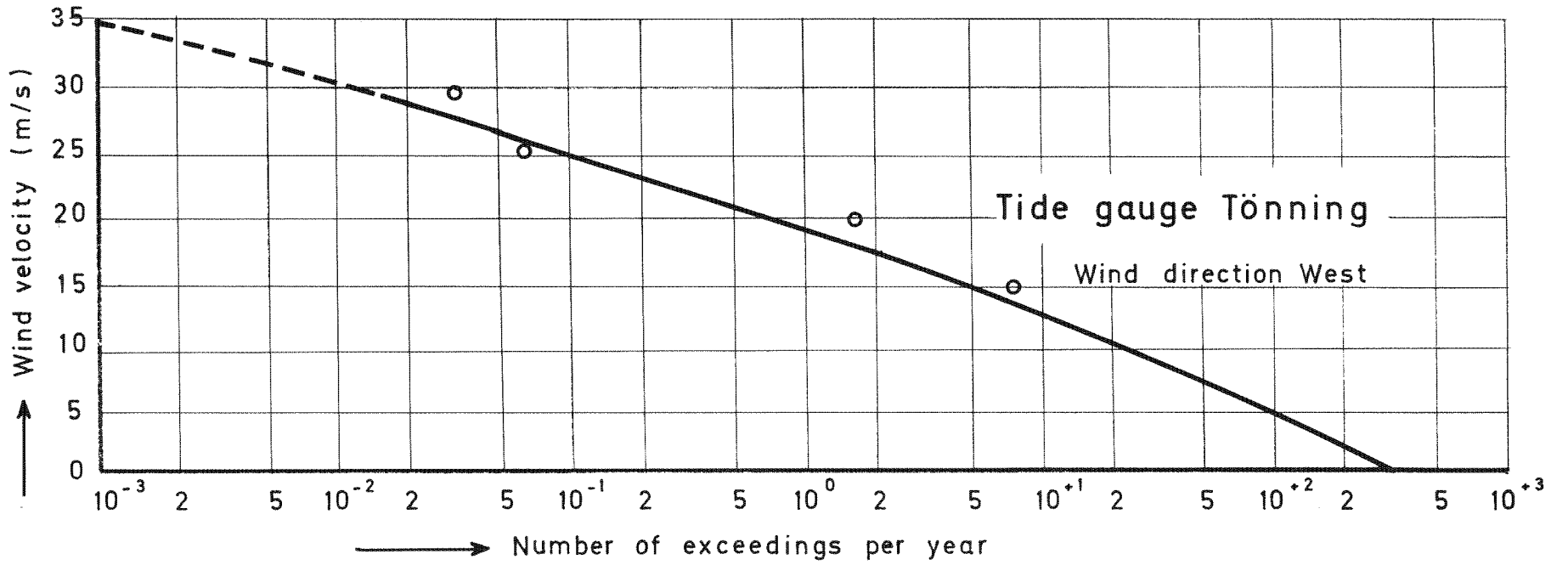

Fig. 6 Probability of the high water-levels

Fig. 7 Probability of the wind velocities



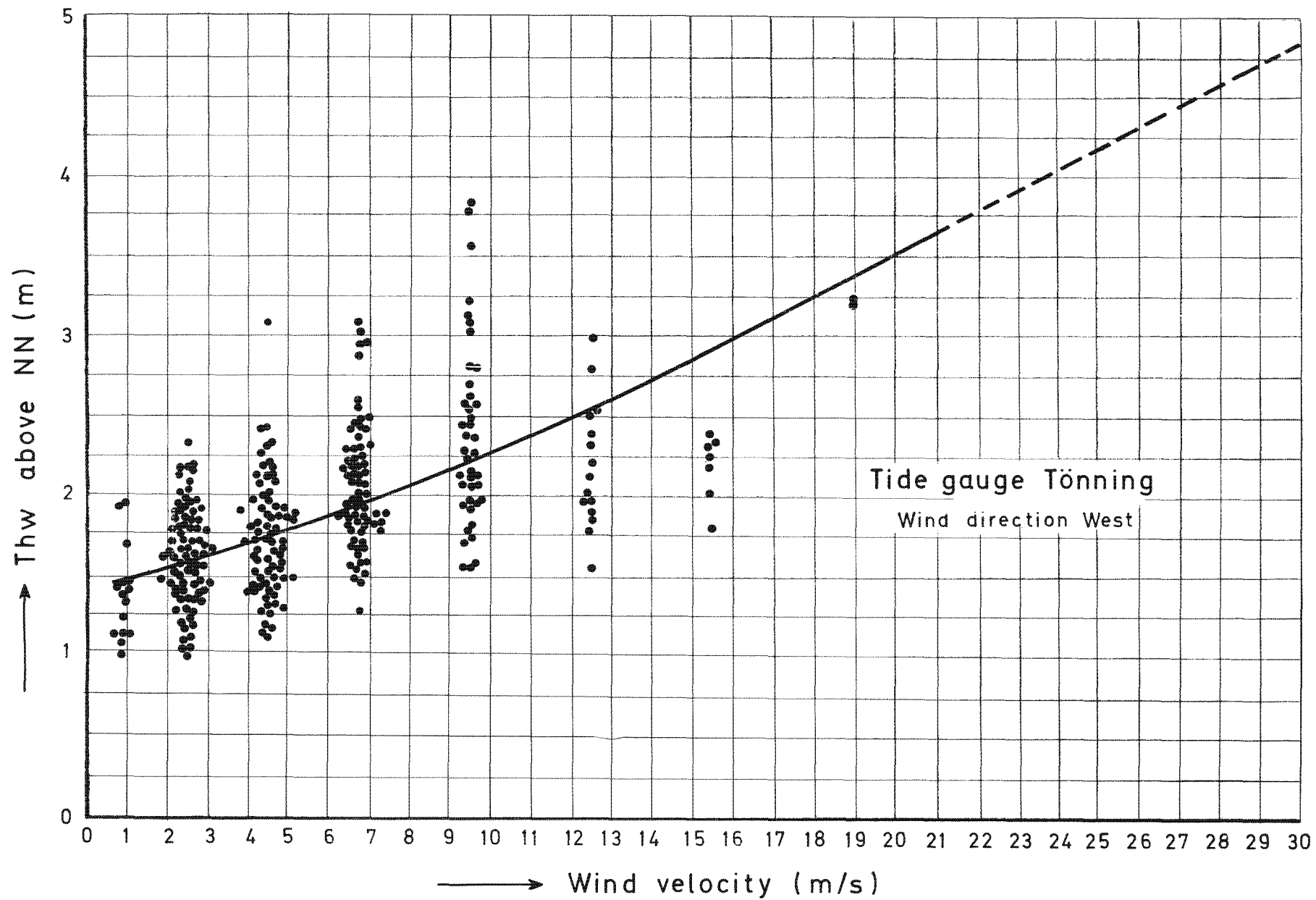

Fig. 8 Relation between high water and wind velocity

** From Figure 8 it appears that a great scatter exists. The reason for this can be found in the fact that the wind set up in Tönning is not only caused by the wind in this region but also by the wind in a region that lies essentially more seaward. The duration of the wind in both the regions can have shifted. In spite of the great scatter, still average relation between the high water-level and the windvelocity can be determined.

The results of this correspond rather well with the relation obtained before. It has been concluded, for instance, that the water-level NN + 5 m corresponds to a mean wind velocity of 30 m/s and the probability of both of them equals 10^{-2} per year.

As also the latest measurements during the storms on the February 23 and October 17, 1967, agree rather well with this correlation, the extrapolation to a probability of 10^{-3} per year seems to be reasonable.

Also sufficient prototype data were not available about the waves especially for high wind velocities. Moreover, the influence of the expected change of the channel system and the shoals on the seaward side of the structure after it has been put into use was necessarily lacking. For this reason, the wave conditions were calculated with the aid of the theories about wave generation by wind and the knowledge about the change of waves by changing water depth (Refs. 1,2,5).

In the present case it had to be considered that possibly waves from the North Sea enter the shallow region in front of the structure. These waves are reduced by the restricted water depth and can later grow again by wind from a westerly direction in the straight channel which will be eventually formed in front of the structure. In this case the maximum possible wave characteristics are still restricted by the water depth in the channel concerned. Information about this can be found in literature.

The assumption of the building-up of a straight channel in front of the structure and its water depth, is of great importance.

The probability calculation for the critical westerly wave direction was carried out with the aid of the scheme shown in Figure 9.

Here the probability calculations had also to be carried out separately for the different situations and for the different critical water-levels. As the intervals of the water-level and the wave heights obtained from the probability calculation did not agree with those of the model investigation for all cases, linear interpolations of the measured wave impact distributions to other water-levels and wave heights were carried out.

The method of the probability calculation can be written in the following mathematical way:

high water intervals

$$W(h, P) = \sum n(h, H_{(1)}, T) \times O(h, H_{(1)}, T, P) \times 10^{-2} \quad (3)$$

Herein

P = An arbitrarily chosen value of the wave force

$W(h, P)$ = The probability with which the wave force P occurs or is exceeded at the water level h

$n(h, H_{(1)}, T)$ = The number of waves occurring per year at the water-level h and with the characteristics $(H_{(1)}, T)$.

$O(h, H_{(1)}, T, P)$ = The percentage of the waves with which the load P occurs or is exceeded at the water-level h and with the wave characteristics $(H_{(1)}, T)$.

$$n[B, H_{(1)}, T] = [W(\text{ThW} = NN + A - 0.5 \text{ m}) - W(\text{ThW} = NN + A + 0.5 \text{ m})] \times \frac{D(A \cdot B)}{T} \times 3,600. \quad (4)$$

Herein

$n[B, H_{(1)}, T]$ = The average number of waves per year with the characteristics $H_{(1)}$ and T occurring at the chosen interval B of the water-level

Fig. 9 Scheme of the probability calculation

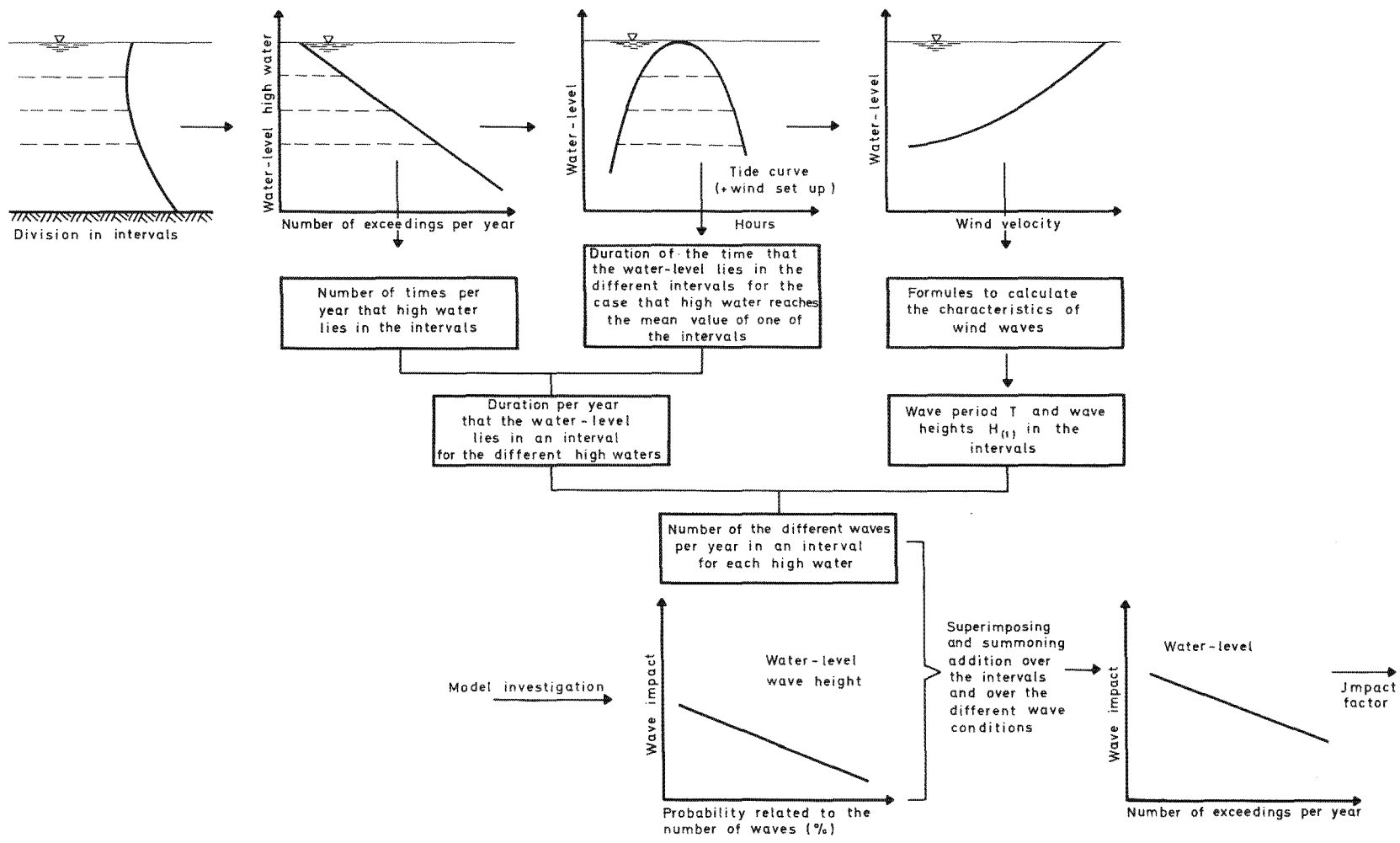

$$W[(ThW = NN + A - 0.5m)] - W(ThW = NN + A + 0.5) =$$

The number of times that high water flood-tide averagely lies in the interval $NN + A - 0.5$ to $NN + A + 0.5$ m.

$D(A,B)$ = The time during which the water-level h lies in interval B at a tide with a high water of $NN + A$.

It has to be noted that the wave characteristics $H_{(1)}$ and T which occur in interval B are determined by the wind velocity which belongs to the high water flood-tide $NN + A$. From (3) and (4) it can be concluded that

High water intervals

$$W[B,P] = 36. \Sigma [W(Thw = NN + A - 0.5 m) - W(Thw = NN + A + 0.5 m)] \times \frac{D(A,B)}{T} \times O[B, H_{(1)}, T, P] \quad (5)$$

From the probability calculation for all water-levels, a representation of the probability curves of the loads related to prototype could be determined. In the investigation the water-levels between $NN + 1.00$ and $NN + 6.00$ m were considered. As an example, the probability curves of the maximum local pressures and of the sum forces at the water-level $NN + 2.00$ m are shown in Figures 10 and 11.

The most dangerous wave attack often exists at relatively low water-levels, because of the high frequency of occurrence of these conditions. Hence the probability curves have to be extrapolated to smaller probabilities for the lower water-levels (Figure 3).

The results of the test show that the maximum pressures occur about at the mean water-level or somewhat above. Only for the outer gate did the maximum pressures occur somewhat below the mean water-level for the higher water-levels. The reason is probably the convex shape of this gate.

It can be seen in Figure 10 that considerably high wave impacts occur on the front side and the under side of the bridge, the latter being even greater than the former. However, it has to be noticed that the accessory distribution factor is rather small.

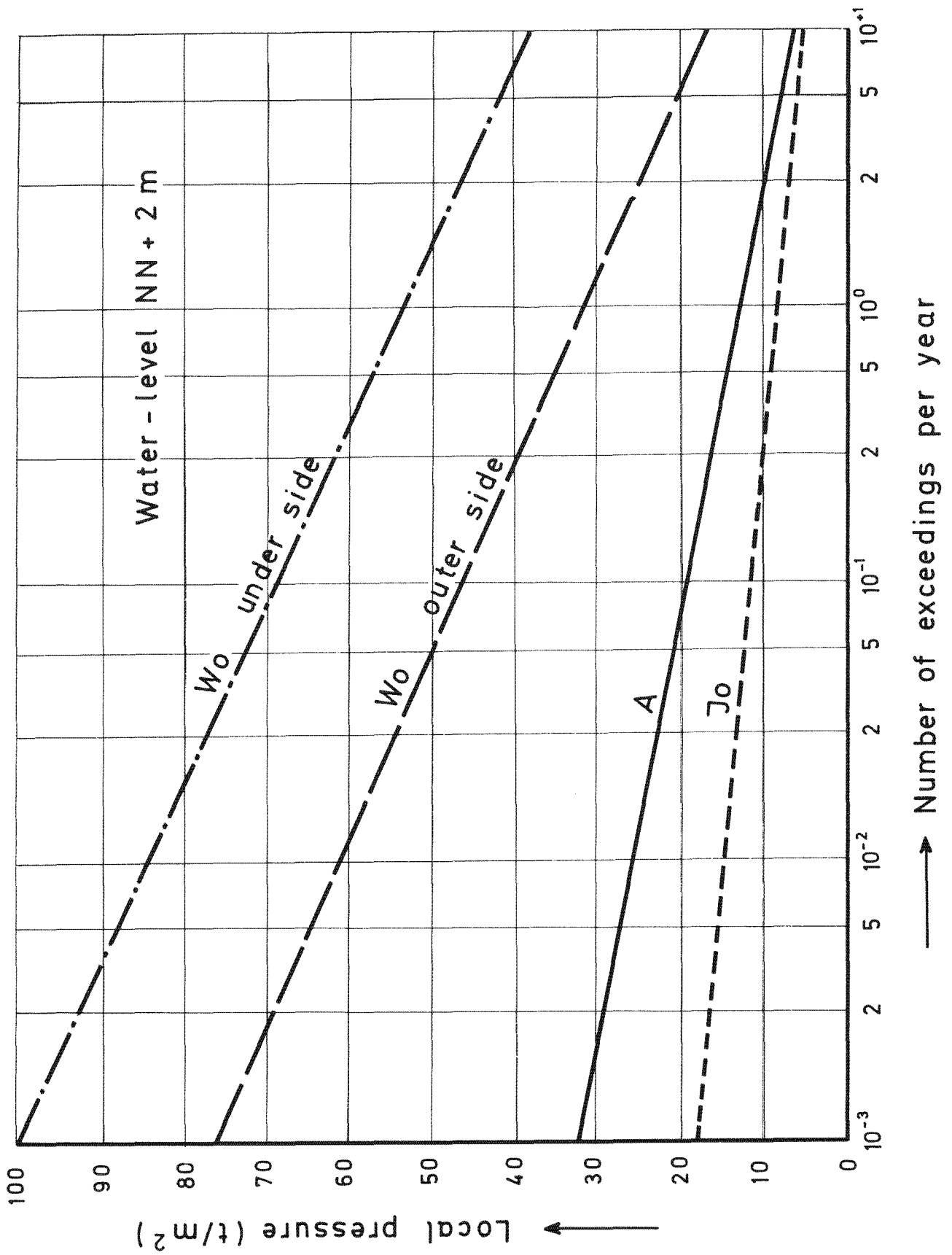

Fig.10 Examples of the probability curves of the maximum local pressures

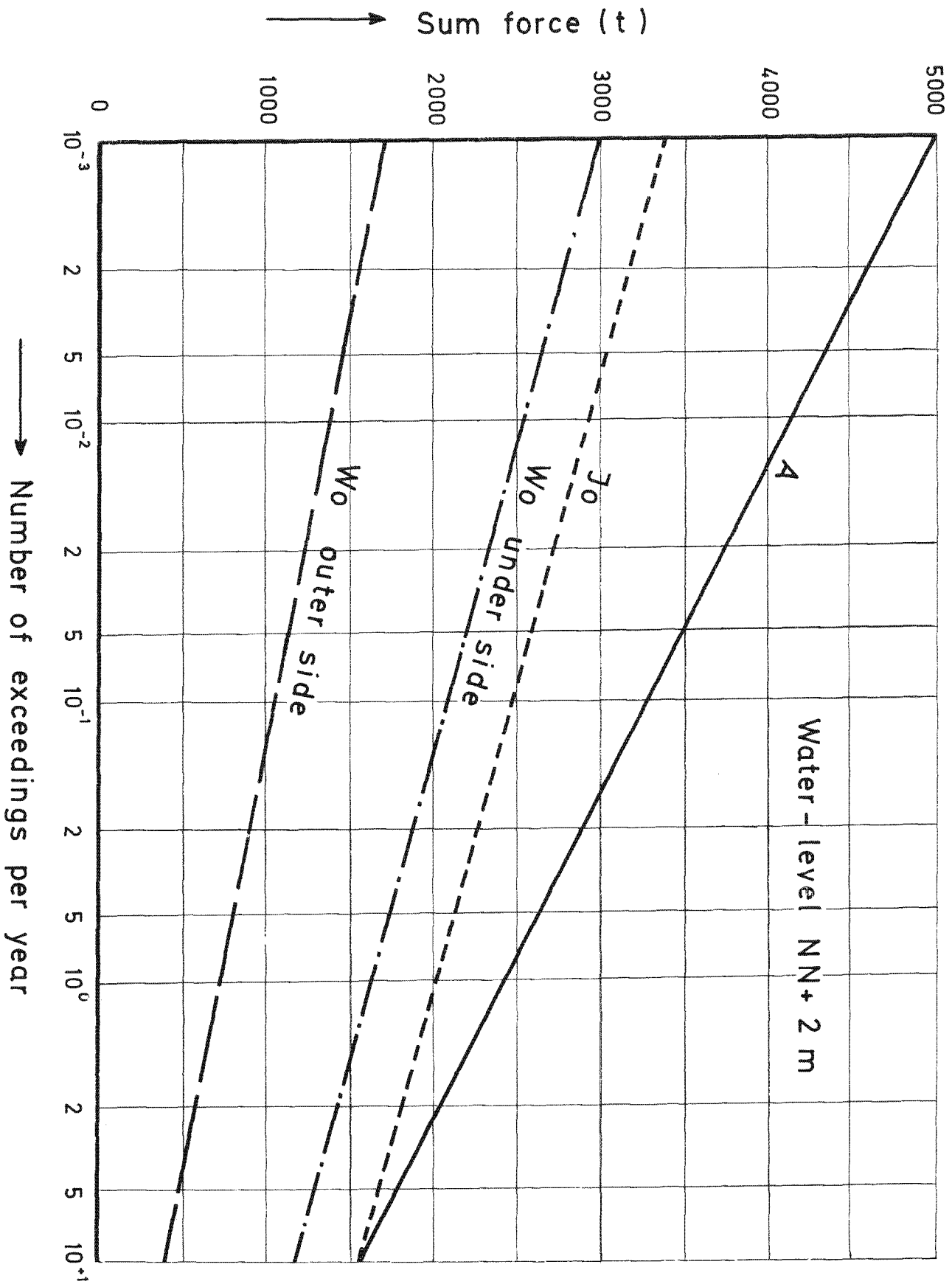

Fig.11 Examples of the probability curves of the sum forces

The maximum wave impacts do not occur over the total area of the structure at the same time, but hit the structure in places and irregularly. This conclusion can be drawn also from the sum force, shown in Figure 11. Here the sum force on the bridge is even smaller than on both the gates.

4. METHOD OF CHOOSING THE CRITICAL LOADS FOR THE STRUCTURE

To determine the dimensions of the gates and the bridge from the model results, an investigation still had to be done into the acceptable probability of circumstances under which failure of the structure is permitted, and into the vertical and horizontal load distributions, and the dynamical response of the structure.

The determination of the criterium of failure can most of the time not be solved in an easy way, and it is also not possible to give a general approach to that problem, because the choice is dependent on the problems of safety, efficiency, local circumstances and accuracy of the model investigation and calculations which have to be judged separately for each case. In this, the structure of the building-up and the settlements of the district which will be protected by the structure are of decisive significance.

In the present case of the Eider sluices, the abovementioned conditions are not critical, because the dike which protects the district now will form a second barrier after the damming up of the Eider has been finished. In effect, a large empty reservoir is being created, the volume of which is about 20,000,000 m³. Damage to the structure during one period of storm will at most result in flood water penetrating the reservoir, which is sufficiently large and which is uninhabited.

****** Taking these arguments into account and after a comprehensive consideration of the safety factors involved in the horizontal and vertical distributions of the loads, as described later on, a failure probability of 10^{-2} per year has been chosen, especially as the connecting dikes have been designed to meet the same conditions.

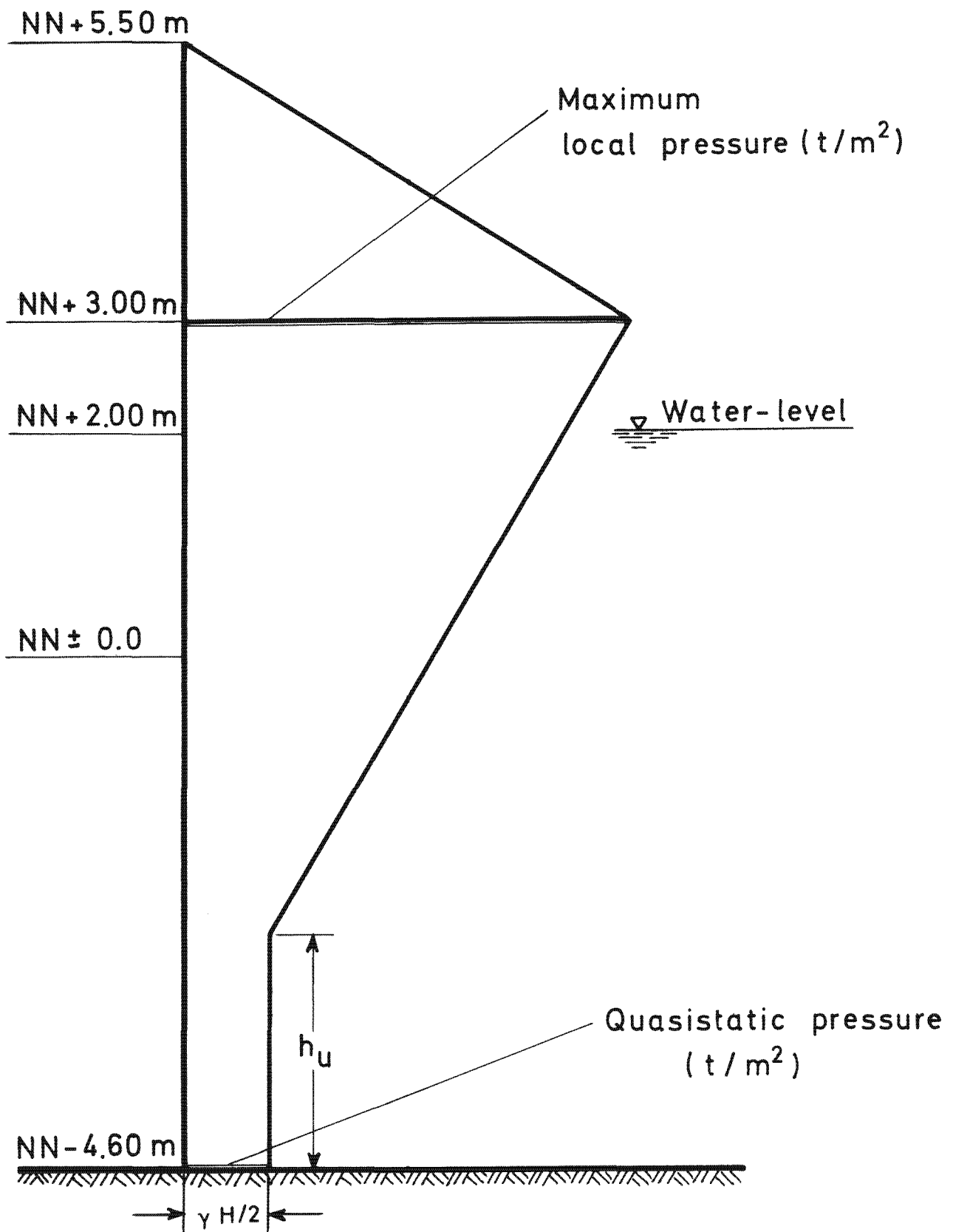

Fig. 12 Vertical load distribution

Figure 12 shows an example of the method of determining the vertical load distribution on the outer gate for the critical water-level $NN + 2m$. The maximum local pressure, determined as already explained was assumed as occurring at the height of $NN + 3 m$, as followed also from the model tests. Further on it was assumed that the pressure decreases upward linearly to zero at the upper side of the gate. The way in which the pressure decreases downward to the quasistatic load caused by the wave motion was determined applying the following suppositions:

1. The total surface of the vertical loading figure, formed as already described, must be equal to the load per running meter distributed uniformly, as can be calculated from the sum load taking the horizontal distribution factor into account.
2. At the bottom the quasistatic force was assumed to be $\frac{H}{2}$ when $\gamma = 1$ (Ref. 4).

The height h_u at which only a pressure $\frac{H}{2}$ occurs can now be calculated.

The method can also be used for determining the vertical load distribution of the other cases.

Further on, the vertical loading distribution determined in this way was assumed to occur at the same time on a certain length of the structure, fixed by the horizontal distribution factor α and the length of the structure, as shown also in Figure 13.

To be safe, the factor α was applied for 10^6 waves.

According to the constructive requirements a choice has to be made between both the loading figures, as shown in Figure 13.

This implies further safety, because the wave impacts do not occur at the same time on such a length of the structure. Nevertheless, the horizontal loading distribution gives an advantage, because the application of the distribution factor, as determined with the aid of the model investigation, leads to an efficient method.

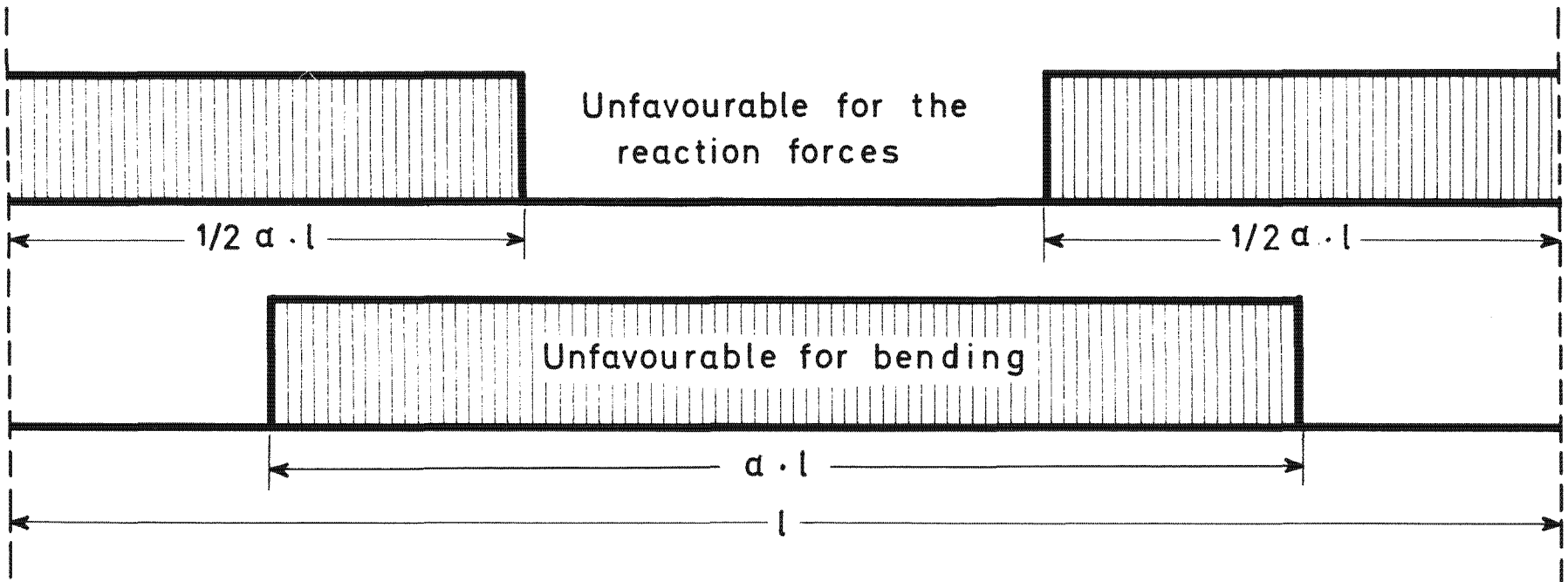

α = horizontal distribution factor

Fig. 13 Horizontal load distribution

After all these investigations it is still necessary to multiply all the wave impact loads which were measured, by an impact factor. This factor depends for every impact on its time-force relationship and on the natural frequencies of the structure or parts of it.

Starting from about 300 typical impulses of wave impacts, as found from the signals on tape at high paper velocity, impact factors were calculated for both the whole structure and for parts of it. In doing this the shape and the construction of the structure had to be taken into account.

The impact factor lies between 1.0 and 1.4. For the turnbearings and the arms of the gates, even an impact factor of 1.55 has to be applied.

All this explanation shows that extensive model tests were carried out to determine the wave forces, and which only together guarantee a safe and efficient dimensioning of the structure against the impacts of the waves.

LIST OF SYMBOLS

A	=	Outer gate (closed)
a	=	Horizontal distribution factor (For the definition see relation 2)
$H_{(1)}$	=	Wave height, exceeded by 1% of the number of the waves attacking the structure
HThW	=	The highest known water-level
h^1	=	Height of the sluice gate or of the concrete bridge
I_m	=	Inner gate (outer gate closed)
I_o	=	Inner gate (outer gate omitted)
l	=	Span of sluice opening (length of a structure part)
NN	=	Mean sea-level
Px	=	Sum load
$\bar{P}_v(x)$	=	Mean wave impact over the vertical
$\bar{P}_h(x)$	=	Mean wave impact over the horizontal
$P^+(x)$	=	Local wave impact at the concerned point
T	=	Mean wave period
Thw	=	High water flood-tide
Wm	=	Concrete bridge (outer gate closed)
Wo	=	Concrete bridge (outer gate omitted)
Index(x)	=	Percentage of exceedings, related to the number of waves.

LIST OF FIGURES

- Fig. 1 General plan of the Eidermouth
- Fig. 2 Cross-section of the evacuation sluices
- Fig. 3 Relation between the wave impacts and their probability, related to the number of waves
- Fig. 4 Example of the three-dimensional view on the load distribution over the surfaces
- Fig. 5 Examples of the horizontal distribution factor
- Fig. 6 Probability of the high water-levels
- Fig. 7 Probability of the wind velocities
- Fig. 8 Relation between high water and wind velocity
- Fig. 9 Scheme of the probability calculation
- Fig.10 Examples of the probability curves of the maximum local pressures
- Fig.11 Examples of the probability curves of the sum forces
- Fig.12 Vertical load distribution
- Fig.13 Horizontal load distribution

LIST OF LITERATURE

- (1) Bundesanstalt für Wasserbau, Aussenstelle Küste, Hamburg : Seegangsrößen in der Eidermündung. Unveröffentl. Bericht Juli 1965.
- (2) Diephuis, J.H.G.R., Grijm, W., Schijf, J.B., Venis, W.A. : Golven en golfoploop. Rapport Delta-commissie, Bijdrage V. 1. Staatsdrukkerij- en Uitgeverij bedrijf, 's-Gravenhage.
- (3) Führböter, A. : Der Druckschlag durch Brecher auf Deichböschungen. Mitt.d.Franzius-Instituts der TU Hannover, Heft 28 (1966).
- (4) Magens, C. : Seegang und Brandung als Grundlage für Planung und Entwurf im Seebau und Küstenschutz. Mitt.d. Franzius-Instituts der TU Hannover, Heft 14 (1958).
- (5) Rijkswaterstaat 's-Gravenhage : Frequenties van golfhoogten en waterstanden op de Maasvlakte als randvoorwaarden voor het ontwerp van de Havenmond van Europoort. Nota K 362 (1965).
- (6) Waterloopkundig Laboratorium, Delft : Eiderabdämmung Wellenbelastungen Sielverschlüsse. Unveröffentl. Versuchsbericht M 915, März 1968.

DISCUSSION ON PAPER 5

W. SIEFERT

Forschungsgruppe Neuwerk, Cuxhaven, Germany

Model tests are normally based on prototype data. As in the Eider mouth wave recordings are not available the authors tried to get some knowledge of the waves - necessary for the model tests - by evaluating tide and wind measurements. The relatively small number of data was completed by assumptions and extrapolations, i.e. probability of tide levels, and mean wind velocity of 30 m/s corresponding to a water level NN + 5 m. Thus these assumptions rule the "prototype" data taken as the basis of the model tests. However, by using fig. 6 - 8 it seems as if the prototype data given there are of great importance for the model tests. So therefore it is worth while to investigate the analysis.

Fig. 6 shows only 2 data (prob. 10^{-1} and Febr. 16th, 1962) with a probability less than $5 \cdot 10^{-1}$. This is not enough for extrapolating the curve to the probability 10^{-3} . As time of observation more than 10 years have to be chosen for an extrapolation like this one. Another point is that even Mr. Wemelsfelder, who first used this way of connecting water levels and probability, demands to be careful in extrapolating.

With the 4 points of fig. 7 a straight line can better be constructed to settle also the combination of fig. 6 and 8 as given in the text. The reasons for taking a curve are missing.

The large scattering of the values in fig. 8 is obviously referring to the astronomic influences on the tide, for even for extremely slow wind the data scatter more than

50 cm to each side. Further on the curve of fig. 8 does not link the centres of the scattering points of the different wind velocities. There is no reason for taking a curve like that in fig. 8. The curve even seems to show that with high wind velocities the water level goes up quicker than with low velocities. A fact to mention is the situation of the weather station of Tønning. The velocities taken at this point are lower than that of the wave-generating wind outside the coast. Besides, another important fact is omitted, i.e. the duration of the wave-generating wind taken from fig. 6 and 8. And above all the used theories about wave generation by wind have not yet shown considerable results in the North Sea.

It would have been necessary to have taken the differences between measured and predicted water levels as functions of the wind in order to get some practicable statements; after all the chosen time of observation (10 years) is too short for getting sufficient data.

Thus in the case discussed approximate estimations would have been more effective than functions that only seem to be the results of scientific research.

DISCUSSION ON PAPER 5

W.A. VENIS

Rijkswaterstaat, The Hague, The Netherlands

In their paper Dietz and Van Staal give a description of the determination of the design-load on the Eider sluices from laboratory and field observations. Reading this paper my attention was drawn by the close resemblance between the general shape of the Eider sluices and of the Haringvliet sluices in the Netherlands. It was with great pleasure that I learned, that there is a resemblance just as close between the procedure, applied by the authors for determining the design-load and that, applied by the Hydraulics Division of the Deltaworks for determining the wave load on the Haringvlietsluices.

The last mentioned procedure is described in: "Determination of the wave attack anticipated upon a structure from laboratory and field observations", which paper I presented at the seventh Congress on Coastal Engineering, held at the Hague in 1960. However there is a difference in the conclusions in the two papers. Therefore, I want to put some questions to the authors of the present paper.

My first question concerns the probability of occurrence of a failure, mentioned in the last paragraph on page 21. The determining frequency of excess has been chosen at 10^{-2} per year, which implies that if the lifetime of the structure will be 100 years, there is a probability of about 60%, that the structure will collapse at least once during that period. This result cannot be based on calculations, related to the econometric decision problem. Therefore my first question is, which factors justify the acceptance of such a high risk.

My second question is related to the first one, more or less. On page 21 the authors discuss the accuracy of the model investigation. I would like to add, that the interpretation of the frequency-curves, based on the model results and especially their extrapolation, has to be taken into account as well. In figure 3 (page 7) the authors present the frequency-

distribution of the wave loads. Looking at this figure I doubt the authors statement, that a logarithmic distribution function provides the best fit to the model results. A representation of these results on log-normal paper gives a far better fit, as my figure 1 shows. The article by Führböter, that the authors refer to on page 8, also learns that the log-normal distribution provides the best fit to the frequency distribution of the wave loads, recorded in his schematized model. Using a logarithmic distribution the authors neglect the statistical behaviour of the higher wave loads, which have a more local character than the lower ones, as stated on page 9.

To me this appears unfavourable, regarding the risk of 10^{-2} per year, accepted for the whole structure.

I also would like to call attention to the fact the extreme values of the wave loads have a frequency of excess, which is greater, than follows from the best fit probability function, both on logarithmic paper and on log-normal paper. I found the same deviation when interpreting the model records for the Haringvlietsluices. Generally this is not in accordance with theories regarding the statistical behaviour of extreme values. Then it was concluded, that these extreme values are connected with a physical background, different from that of the lower values of the wave loads.

Therefore I want to put the following questions:

- a. Will the authors clearly indicate, why they chose the logarithmic distribution as the best fit to the statistical behaviour of the local loads.
- b. Have the authors any idea, why the statistical behaviour of the extreme values of the wave loads is different from that of the lower values.

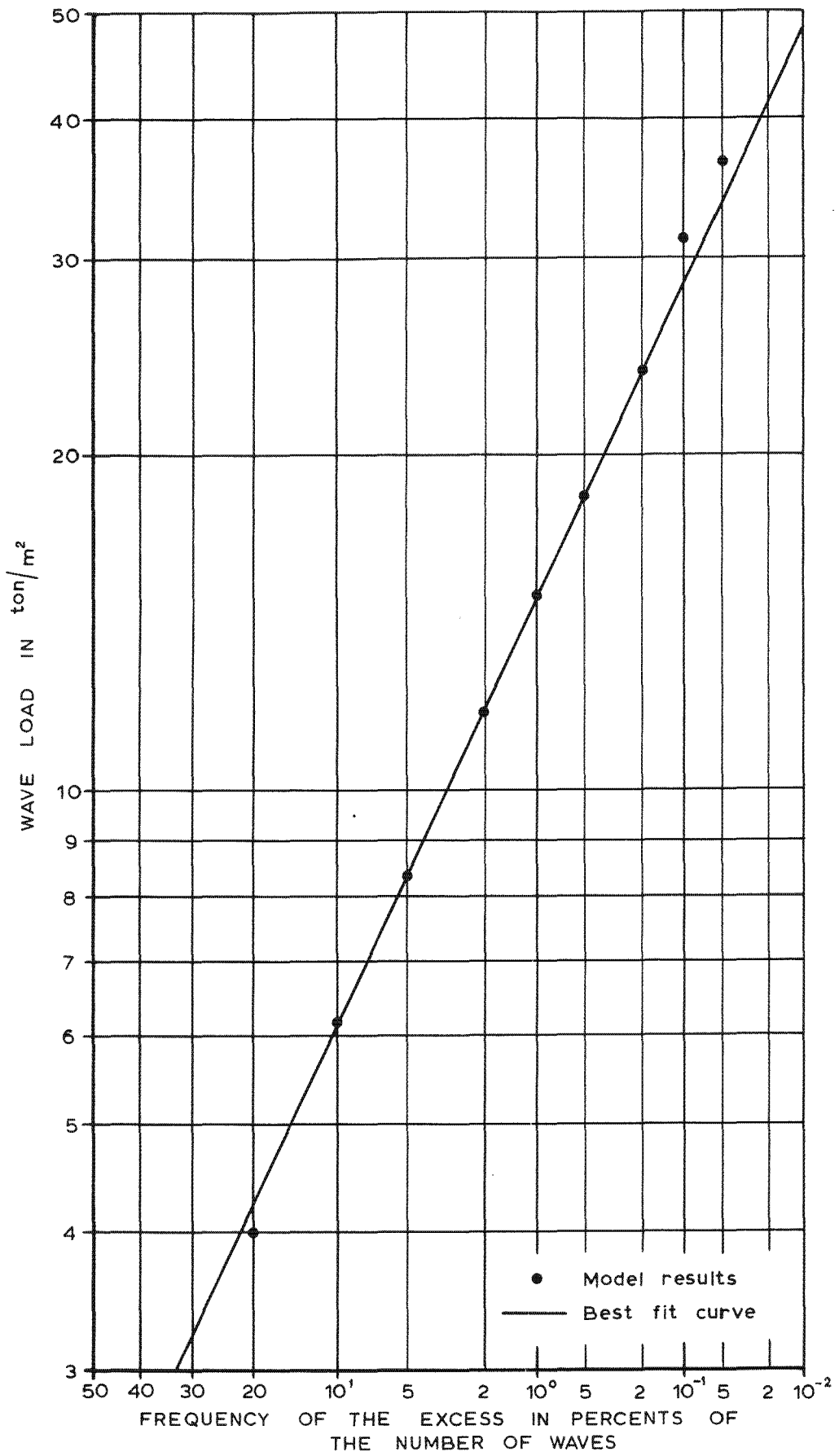

Fig. 1

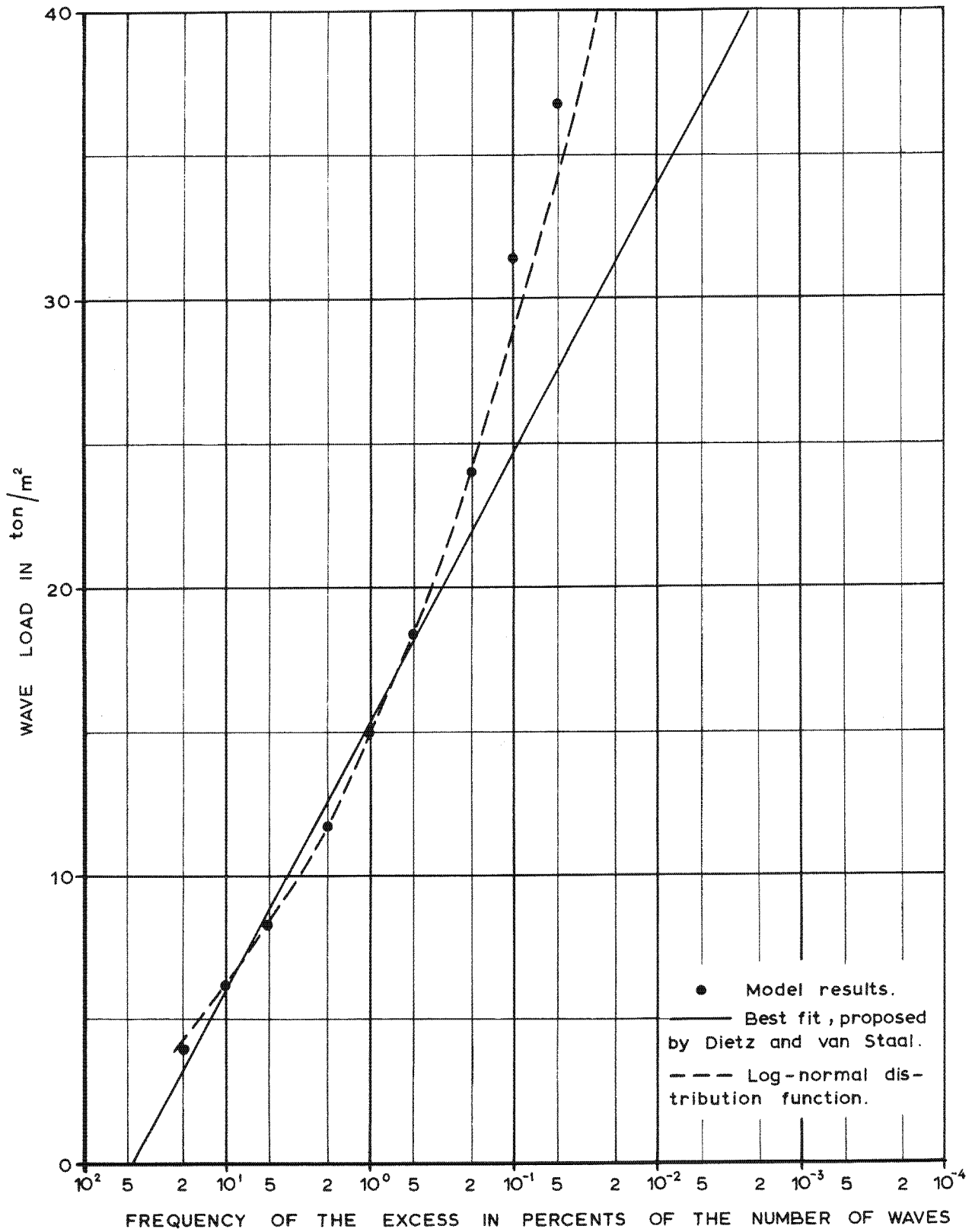

Fig. 2