

# Wave induced growth and evaporation of droplets in a vapor-gas mixture

**Citation for published version (APA):**

Smolders, H. J., Willems, J. F. H., Lange, de, H. C., & Dongen, van, M. E. H. (1990). Wave induced growth and evaporation of droplets in a vapor-gas mixture. In W. K. Yong (Ed.), *Current topics in shock waves : 17th international symposium on shock waves and shock tubes, Bethlehem, Pa., 1989* (pp. 802-807). (AIP Conference Proceedings; Vol. 208). American Institute of Physics. <https://doi.org/10.1063/1.39472>

**DOI:**

[10.1063/1.39472](https://doi.org/10.1063/1.39472)

**Document status and date:**

Published: 01/01/1990

**Document Version:**

Publisher's PDF, also known as Version of Record (includes final page, issue and volume numbers)

**Please check the document version of this publication:**

- A submitted manuscript is the version of the article upon submission and before peer-review. There can be important differences between the submitted version and the official published version of record. People interested in the research are advised to contact the author for the final version of the publication, or visit the DOI to the publisher's website.
- The final author version and the galley proof are versions of the publication after peer review.
- The final published version features the final layout of the paper including the volume, issue and page numbers.

[Link to publication](#)

**General rights**

Copyright and moral rights for the publications made accessible in the public portal are retained by the authors and/or other copyright owners and it is a condition of accessing publications that users recognise and abide by the legal requirements associated with these rights.

- Users may download and print one copy of any publication from the public portal for the purpose of private study or research.
- You may not further distribute the material or use it for any profit-making activity or commercial gain
- You may freely distribute the URL identifying the publication in the public portal.

If the publication is distributed under the terms of Article 25fa of the Dutch Copyright Act, indicated by the "Taverne" license above, please follow below link for the End User Agreement:

[www.tue.nl/taverne](http://www.tue.nl/taverne)

**Take down policy**

If you believe that this document breaches copyright please contact us at:

[openaccess@tue.nl](mailto:openaccess@tue.nl)

providing details and we will investigate your claim.

# WAVE INDUCED GROWTH AND EVAPORATION OF DROPLETS IN A VAPOUR-GAS MIXTURE

H.J. Smolders, J.F.H. Willems, H.C. de Lange, M.E.H. van Dongen.  
Dept. of Physics, Eindhoven University of Technology,  
P.O. Box 513, NL-5600 MB Eindhoven, The Netherlands.

## ABSTRACT

Heterogeneous condensation and evaporation induced by an unsteady rarefaction wave and by the passage of a shock wave in a water-nitrogen mixture is studied. Time resolved measurements of modal droplet radius, droplet number density, pressure, and gas density are presented. Condensation on  $\text{Cr}_2\text{O}_3$ -particles of about 10 nm starts at a saturation ratio of 3.4. Typical droplet radii and droplet number densities are 1.5  $\mu\text{m}$  and  $10^{11} \text{ m}^{-3}$ . A shock wave with Mach number 1.36 causes full evaporation in 4 ms.

## INTRODUCTION

Mixtures of vapour, gas and droplets are easily brought in a state of thermodynamic non-equilibrium, since growth and evaporation of droplets are relatively slow processes. A shock tube, or more generally a wave tube, can be used pre-eminently to study the properties of such gas-droplet mixtures. After the initiating work of Wegener<sup>1</sup> and Barschdorff<sup>2</sup>, many contributions<sup>3-4-5</sup> to the study of homogeneous and heterogeneous nucleation and condensation in unsteady rarefaction waves have been published. In addition, Roth and Fischer<sup>6</sup>, and Goossens et al.<sup>7</sup> reported on shock wave induced evaporation of droplets.

Obviously, in such studies it is important to characterize the state of the fog experimentally by state variables as droplet number density, modal droplet radius and width of the size distribution function. Optical methods are preferable because of their non-interfering character and their ability for direct and fast recording. One of these methods is the light extinction method originally proposed by Teorell<sup>8</sup> and more recently tested by Wittig<sup>9</sup>. It is based on the principle that attenuation of a light beam passing a suspension of particles depends on wavelength and on size and number density of the particles.

This paper presents a wave study concerning the growth of droplets on heterogeneous nuclei in an unsteady rarefaction wave in a vapour-gas mixture and the subsequent recompression of the mixture by a shock wave, inducing the droplets to evaporate. It also deals with an extended form of the original light extinction method, using the measured attenuation of three light beams with different wavelengths to determine the modal droplet radius and droplet number density, and to estimate the width of the droplet size distribution function.

## A THREE-WAVELENGTHS LIGHT EXTINCTION METHOD

A polydisperse cloud of particles is assumed to satisfy a Zeroth Order Lognormal Size Distribution<sup>10</sup> with modal particle radius  $r_m$  and relative width  $\epsilon$ :

$$F(r) = \frac{1}{\sqrt{2\pi} \epsilon r_m} \exp \left[ - \left[ \frac{\ln(r/r_m)}{\epsilon\sqrt{2}} \right]^2 - \frac{\epsilon^2}{2} \right]. \quad (1)$$

The total mass of the particles per unit volume  $\rho_p$  can be expressed in the total particle number density  $n_p$  and the density of the particle material  $\rho_m$  by:  $\rho_p = 4/3\pi\langle r^3 \rangle \rho_m n_p$ , where  $4/3\pi\langle r^3 \rangle$  is the averaged volume of the particles.

This cloud of particles will attenuate an illuminating light beam by scattering and by absorption. The Lambert-Beer law relates the transmitted and incident intensities  $I$  and  $I_0$  to the thickness of the particulate medium:  $I = I_0 \exp(-\beta L)$ , where the extinction coefficient  $\beta$  can be written as:  $\beta = n_p \pi \langle r^2 Q \rangle$ . Here  $\pi \langle r^2 Q \rangle$  is the averaged extinction cross-section and  $Q$  is the extinction efficiency depending on the ratio  $r/\lambda$  of particle radius and wavelength and on the relative index of refraction  $m$ .  $Q$  can be calculated for spherical particles using Mie theory<sup>11</sup>.

The dispersion quotient  $\beta_{ij}$ , i.e. the ratio of the extinction coefficients  $\beta_i$  and  $\beta_j$  at two different wavelengths, is only depending on the parameters  $r_m$  and  $\epsilon$  of the particle size distribution function:  $\beta_{ij} = \langle r^2 Q_i \rangle / \langle r^2 Q_j \rangle$ . Using three different wavelengths, two independent dispersion quotients  $\beta_{12}$  and  $\beta_{32}$  are obtained from which  $r_m$  and  $\epsilon$  can be determined. An example is shown in Fig. 1. Once these parameters are known the particle number density  $n_p$  and the particle mass density  $\rho_p$  can be calculated.

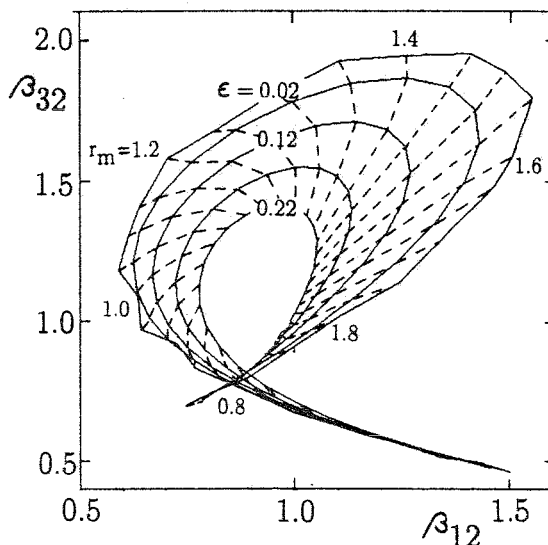

Fig. 1. Theoretical dependence of dispersion quotients  $\beta_{12}$  and  $\beta_{32}$  on modal particle radius  $r_m$  and relative width  $\epsilon$  for water droplets; the dotted and the solid curves correspond to constant  $r_m$  and  $\epsilon$ , respectively;  $r_m$  ( $\mu\text{m}$ );  $\lambda_1 = 632.8$  nm,  $m_1 = 1.3318$ ,  $\lambda_2 = 807$  nm,  $m_2 = 1.3282$ ,  $\lambda_3 = 1152$  nm,  $m_3 = 1.3226$ .

## EXPERIMENTAL METHODS

Wave induced growth and evaporation of droplets in a vapour-gas mixture is studied by means of the experimental set-up described earlier<sup>7</sup> and shown in Fig. 2. The test section consists of a 12.80 m long tube with a square cross-section. Polyester membranes initially separate the test section from a high pressure section filled with driver gas and a low pressure section at vacuum. All the experiments are performed with a mixture of water vapour and nitrogen gas at an initial pressure of 1 bar in the test section.  $\text{Cr}_2\text{O}_3$ -particles with a size of the order of 10 nm are added to the mixture to stimulate heterogeneous condensation. Bursting the membrane at the low pressure side causes a rarefaction wave to travel into the test section. The depth of the expansion is controlled by an orifice between test section and vacuum vessel. The mixture expands adiabatically and the degree of saturation will increase, resulting in dropwise condensation of water vapour. After the passage of the reflected wave a stagnant fog is obtained which remains stationary until the next reflected wave arrives. By opening the second

membrane a shock wave is formed in the fog, causing the droplets to evaporate.

At the observation point at 6.2 m from the high pressure section membrane, measurements are performed of pressure with a piezo-electric transducer (Kistler 603B) and of gas density with a Mach Zehnder interferometer<sup>12</sup>. In addition a three-wavelengths light extinction set-up is used to determine modal droplet radius  $r_m$ , relative width  $\epsilon$ , droplet number density  $n_p$  and droplet mass density  $\rho_p$ . In the present set-up two He-Ne lasers (SpectraPhysics Stabilite model 120, 5 mW) with wavelengths 632.8 nm and 1152 nm, and a diode laser (Philips N515CQL) with wavelength 807 nm are used as light sources. The Gaussian  $e^{-2}$ -beam diameter of the two He-Ne lasers is 0.8 mm, while the beam diameter of the diode laser is reduced from originally 2.4 mm to 0.8 mm. Reference beams, obtained by means of beam splitters, are used to measure the variation of laser output. The measuring beams pass the shock tube at the same axial position and 7 mm apart in lateral direction. Their intensities are measured with photo-diodes (Telefunken BPW34, EG&G YAG-100). The detection of light scattered by the droplets in the shock tube is reduced to a minimum by a lens-pinhole combination with an opening angle for the scattered light of  $0.23^\circ$ .

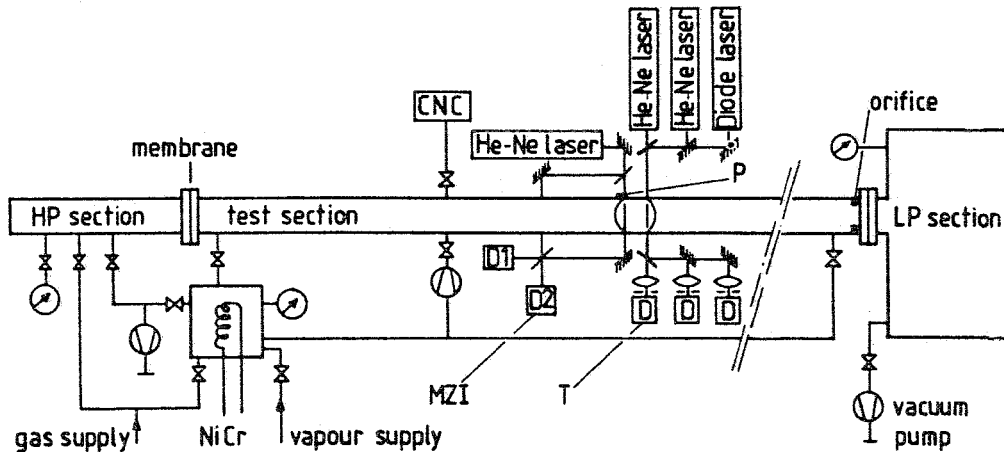

Fig. 2. Schematic diagram of the experimental set-up; NiCr: production of condensation nuclei; CNC: condensation nuclei counter; MZI: Mach Zehnder interferometer; P: pressure transducer; T: laser light transmission measurements at wavelengths of 632.8 nm, 807 nm and 1152 nm.

## EXPERIMENTAL RESULTS AND DISCUSSION

A typical experimental observation of the growth of water droplets due to the unsteady expansion of a mixture of water vapour and nitrogen gas is shown in Fig. 3. Initial conditions are:  $p_0 = 0.982$  bar,  $T_0 = 295$  K,  $\rho_0 = 1.11$  kg/m<sup>3</sup>,  $f_{v0} = 0.015$ , where  $f_{v0}$  is initial vapour mass fraction. The signals of the three-wavelengths light extinction set-up are depicted in Fig. 3a as a trajectory in the  $\beta_{12}$ - $\beta_{32}$  plane. From these signals  $n_p$ ,  $r_m$  and  $\rho_p$  are determined. Temperature is calculated from pressure and density using:  $T = p/\rho R_0$ , with  $R_0$  as initial specific gas-constant of the mixture. The saturation ratio  $\chi$  is defined as the ratio of vapour pressure  $p_v$  and equilibrium vapour pressure  $p_{ve}$ :  $\chi = p_v/p_{ve}$ . The vapour pressure can be written as:  $p_v = (\rho f_{v0} - \rho_p) R_v T$ , and the equilibrium vapour pressure depends on temperature according to the Clausius-Clapeyron equation. The temperature and droplet mass density are compared with 'isentropic' values. These values are equilibrium values, calculated from the

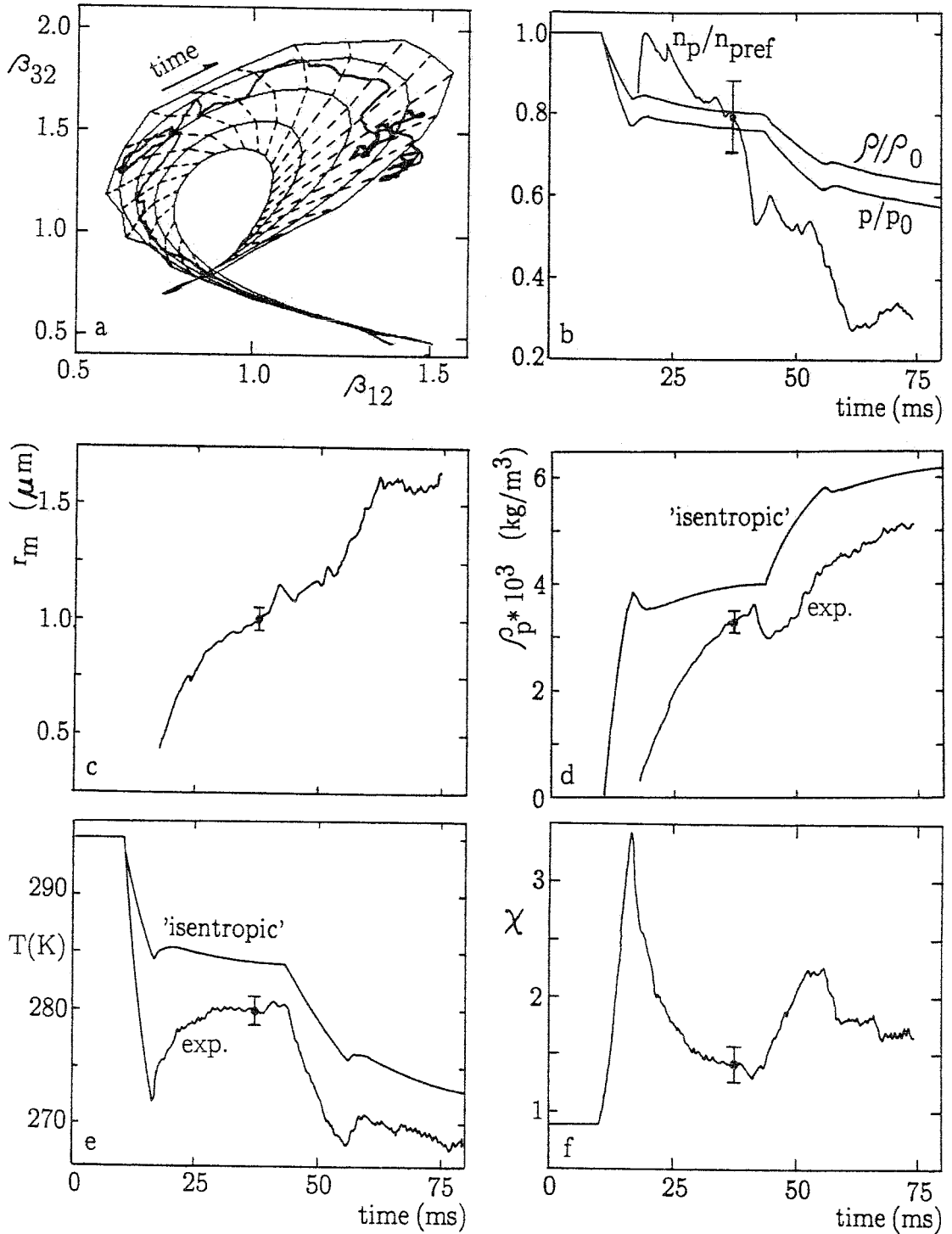

Fig. 3. Typical unsteady rarefaction wave experiment with heterogeneous condensation in mixture of nitrogen gas and water vapour; a. trajectory in  $\beta_{12}$ - $\beta_{32}$  plane; b. pressure, density and droplet number density; c. modal droplet radius; d. experimental and 'isentropic' droplet mass density; e. experimental and 'isentropic' temperature; f. saturation ratio; 'isentropic' quantities calculated from pressure signal assuming no entropy change with respect to initial state;  $p_0 = 0.982$  bar,  $T_0 = 295$  K,  $\rho_0 = 1.11$  kg/m<sup>3</sup>,  $f_{v0} = 0.015$ ;  $n_{pref} = 9 \cdot 10^{11}$  m<sup>-3</sup>.

pressure signal, assuming no entropy change with respect to the initial state.

The expansion of the mixture is isentropic until the onset of condensation at the tail of the first rarefaction wave. There, the saturation ratio is increased from its initial value  $\chi_0 < 1$  to the maximum critical value of about 3.4. Because the 'isentropic' saturation ratio is not allowed to increase above unity, the experimental and 'isentropic' curves start to deviate as soon as  $\chi = 1$ . Due to condensation vapour disappears and latent heat is released, resulting in an increase of temperature and a decrease of saturation ratio. During growth of the droplets the relative width of the droplet size distribution function is seen to vary between 0.07 and 0.12. Passage of the reflected rarefaction wave gives a renewed supersaturation and a renewed droplet growth. The unexpected strong decrease of droplet number density is not yet understood.

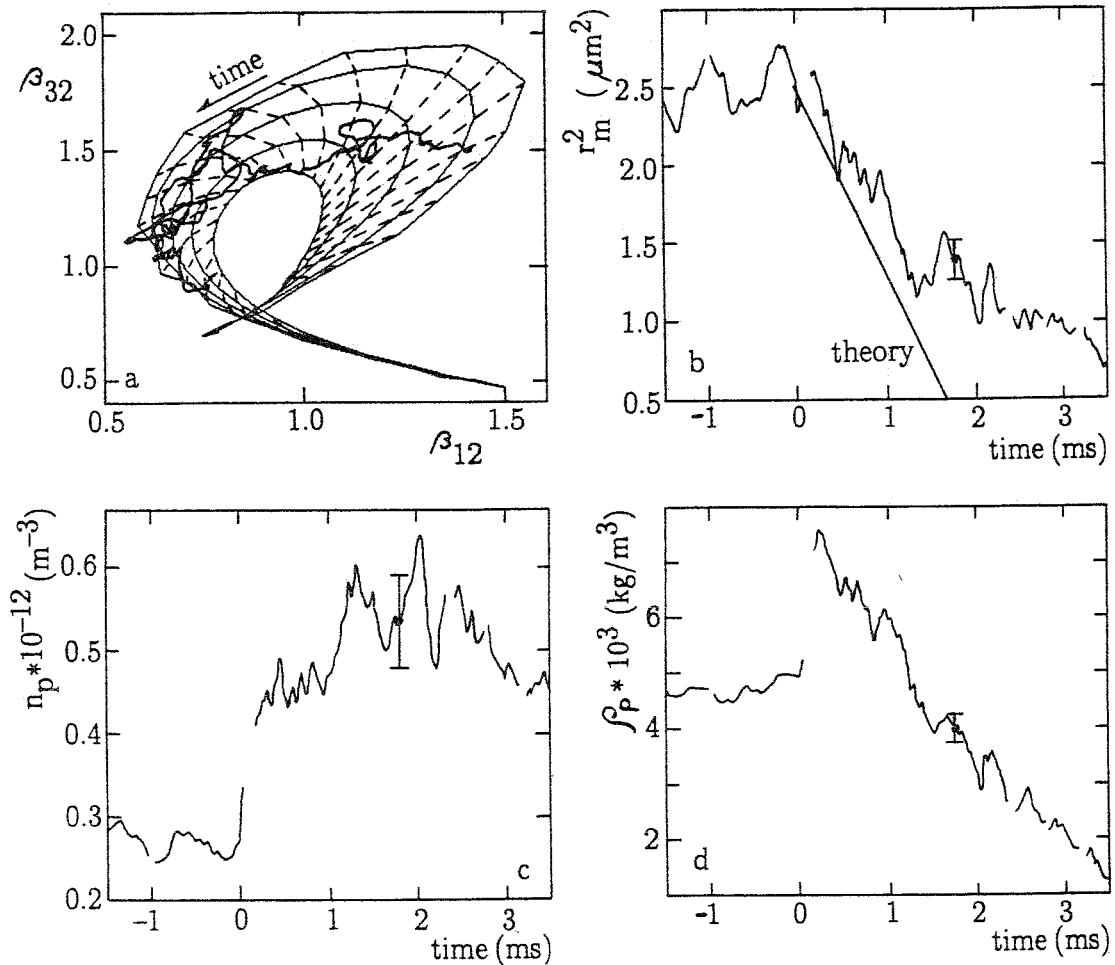

Fig. 4. Typical recordings of shock induced evaporation of water droplets; a. trajectory in  $\beta_{12}$ - $\beta_{32}$  plane; b. modal droplet radius squared; c. droplet number density; d. droplet mass density; the shock wave passes at the point of observation at  $t = 0$ ; pre-shock:  $p = 0.602$  bar,  $T = 272$  K,  $\rho = 0.742$  kg/m<sup>3</sup>,  $f_v = 0.0087$ ,  $f_p = 0.0063$ ; Mach number is 1.36.

After the unsteady expansion of the mixture of water vapour and nitrogen gas a stagnant fog is obtained. Then, the passage of a shock wave causes the water droplets to evaporate. Typical recordings of this part of the experiment are shown

in fig. 4. The shock wave passes the point of observation at  $t = 0$ . Pre-shock conditions are:  $p = 0.602$  bar,  $T = 272$  K,  $\rho = 0.742$  kg/m<sup>3</sup>,  $f_v = 0.0087$ ,  $f_p = 0.0063$ . The shock Mach number is deduced from the pressure jump:  $M = 1.36$ . The evaporation of the droplets is displayed as a trajectory in the  $\beta_{12}$ - $\beta_{32}$  plane. Large values of relative width  $\epsilon$  are observed. Again  $r_m$ ,  $n_p$  and  $\rho_p$  are calculated from the dispersion quotients. Shock wave passage induces a step-wise increase of  $n_p$  and  $\rho_p$ , while  $r_m$  remains unaffected. This can be understood, since momentum relaxation proceeds at a much shorter time scale than evaporation<sup>7</sup>. The jump in  $n_p$  and  $\rho_p$  agrees within two percent with the jump in density calculated from the shock relations. Decrease of modal droplet radius squared is compared with a simple theoretical model<sup>7</sup>. This model neglects the effects of evaporation on the state of the gas and predicts a linear relation between modal droplet radius squared and time. The initial rate of change of  $r_m^2$  agrees well with the theoretical prediction. Later deviation must be explained by the restricted validity of the theoretical model, since for weak shocks the latent heat of the droplets cannot be neglected with respect to the enthalpy change of the carrier gas across the shock wave.

In conclusion, the extinction method yields quite reasonable results, since  $\rho_p$  has the expected magnitude and shows the correct behaviour. Yet, the decrease of droplet number density in the rarefaction wave seems to be too strong. A restriction of the method is that an a priori assumption of the shape of the size distribution has to be made.

#### ACKNOWLEDGEMENTS

The authors are indebted to P.J. de Wit for his enthusiasm and assistance in the experimental work and to H.J. Jager and E.J. van Voorthuisen for their contribution and support.

#### REFERENCES

1. P.P. Wegener, G. Lundquist, *J. Appl. Phys.* **22**, 233 (1951).
2. D. Barschdorff, *Phys. Fluids* **18**, 529 (1975).
3. I.I. Glass, S.P. Kalra, J.P. Sislian, *AIAA J.* **15**, 686 (1977).
4. F. Peters, *Exp. Fluids* **1**, 143 (1983).
5. G.H. Spiegel, R.A. Zahoransky, S.L.K. Wittig, *Proc. 15<sup>th</sup> Int. Symp. Shock Waves and Shock Tubes*, Eds. D. Bershader and R. Hanson, Stanford Univ., 775 (1985).
6. P. Roth, R. Fischer, *Phys. Fluids* **28**, 1665 (1985).
7. H.W.J. Goossens, J.W. Cleijne, H.J. Smolders, M.E.H. van Dongen, *Exp. Fluids* **6**, 561 (1988).
8. T. Teorell, *Kolloid Z.* **54**, 150 (1931).
9. S. Wittig, R.A. Zahoransky, Kh. Sakbani, *J. Aerosol Sci.* **12**, 183 (1981).
10. M. Kerker, *The scattering of light*. (Academic Press, New York, 1969).
11. C.F. Bohren, D.R. Huffman, *Absorption and scattering of light by small particles*. (J. Wiley & Sons, 1983).
12. H.W.J. Goossens, M.E.H. van Dongen, *Exp. Fluids* **5**, 189 (1987).