

Wave21

Drinking Water for the 21st Century Final Report



Publication Details

Publisher

Eawag: Swiss Federal Institute of Aquatic Science
and Technology
8600 Dübendorf/Switzerland

Authors

Urs von Gunten
Thomas Egli
Frederik Hammes
Jakob Helbing
Ralf Kaegi
Wouter Pronk

Access:

Empa/Eawag Library, Dübendorf, Switzerland
ISBN-Nr. 978-3-906484-48-8
Download: <http://library.eawag-empa.ch/schriftenreihe.htm>

Citation:

Eawag (Publ.) 2009: Wave21 final report – Drinking Water
for the 21st Century
Schriftenreihe Nr. 20

Layout

Yvonne Lehnhard, Eawag

Title photo

Pilotplant Lengg
© Eawag, Andri Pohl

October 2009

Schriftenreihe der Eawag Nr. 20

Wave21

Drinking Water for the 21st Century

Final Report

ACKNOWLEDGMENT

The success of this cross-cutting project was only possible due to the contributions of many experts. In particular, we would like to acknowledge the constructive collaboration and support of the members of the advisory board:

- Adrian Auckenthaler, BAG, AUE Baselland
- Alfred Besl, Kantonales Labor, Zurich
- Rolf Etter, Kantonales Labor, Zurich
- Willi Gujer, Eawag
- Joachim Klahre, Membratec, Sierre
- Daniel Lavanchy, Ingenieurbüro Grombach, Volketswil
- Erich Mück, Water Supply Zurich, WVZ
- Stephan Müller, BAFU
- Kurt Rüegg, Energie Wasser, Luzern
- Pierre Studer, BAG

Within the project, the collaboration of Eawag, Water Supply Zurich (WVZ) and Wabag was very stimulating and rewarding. We would like to thank the following people from WVZ and Wabag: Hans-Peter Klein, Cordula Berger, Alexander Betschart, Heinz Bischofberger, Ueli Bosshart, Arnold Gmünder, Peter Hartmann, Hans-Peter Kaiser, Elvira Keller, Oliver Köster, Marcel Leemann, Joachim Lenzner, Erich Lüscher, Christoph Matter, Peter Müller and Harald Tarnowski.

Last but not least our thanks goes to the following Eawag research staff for making this project so interesting and successful: Markus Boller, Markus Gresch, Doris Jermann, Holger Lutze, Sébastien Meylan, Marc Neumann, Andreas Peter, Maryna Peter, Maaïke Ramseier, Jörg Rüedi, Lisa Salhi, Brian Sinnet, Jacqueline Traber, Silvana Velten, Claire Wedema and Hans Ulrich Weilenmann.

Eawag and BAFU are also acknowledged for funding this project.

ABOUT THIS REPORT

This report gives an overview over the cross-cutting project Wave21. In the first part, the overarching questions and the objectives are discussed. In the second part an overview of the key results will be given in form of executive summaries. More details are given in the published papers and the PhD theses which are listed for each chapter. In the third part, the experiences in this project are summarized and an outlook and recommendations for future activities in the field of drinking water are given.

TABLE OF CONTENTS

INTRODUCTION	6
1 ANALYTICAL TOOLBOX	10
1.1 MICROBIOLOGY	10
1.2 CHARACTERISATION OF NOM	15
1.3 PARTICLES	20
1.4 TASTE AND ODOR COMPOUNDS	23
1.5 MICROPOLLUTANTS	27
2 TECHNOLOGICAL TOOLBOX	30
2.1 OXIDATION PROCESSES	30
2.2 MEMBRANE TECHNOLOGY	34
2.3 ADSORPTION PROCESSES	38
3 OUTLOOK AND RECOMMENDATIONS	41
4 LIST OF WAVE21 PUBLICATIONS	42

INTRODUCTION

MOTIVATIONS FOR THE CROSS-CUTTING PROJECT WAVE21

After several decades of relative conservatism, at present many factors are requiring extensive innovations in drinking water production and led to this project. The most important of these factors are:

- Increased number and type of chemical and biological contaminants in raw water sources. These are accompanied by more stringent drinking water regulations (e. g. EU, USEPA).
- Better analytical methods for the assessment of drinking water quality.
- Availability of innovative treatment technologies and need for more efficient treatment scenarios.
- Increased pressure on high-quality ground water reserves.
- Particular for the situation in Switzerland:
 - Low or no residual disinfectant in the distribution systems.
 - Need for renovation or restructuring of many water treatment plants within the next 20–30 years.
 - No center of expertise which develops scenarios for this renovation process in Switzerland.

At Eawag, traditionally various research groups in many departments have been active in the field of drinking water. They have covered internationally recognized basic research (disinfection, oxidation, adsorption, etc.) as well as local applications of technologies such as membranes, adsorption and (advanced) oxidation/disinfection processes. However, the overall assessment of drinking water from source to tap requires a concerted action of many different disciplines including environmental chemistry, biology and engineering. Eawag is one of the few institutes worldwide where all these disciplines and the required infrastructure/support are available to guarantee a long-term effort in this field. The cross-cutting project Wave21 is a joint effort to create a nationally and internationally recognized reference center for drinking water. This multi-disciplinary approach leads to a broader view of the field allowing innovations for future drinking water scenarios.

Within the Wave21 project drinking water quality and treatment aspects were investigated according to Fig. 1. On the three axes of Fig. 1 representing water quality, processes and scale, the activities within Wave21 are illustrated. In the field of water quality analytical methods were developed to assess drinking water. In addition to traditional methods, novel analytical tools for parameters such as taste and odor, total cell count, assimilable organic carbon, natural organic matter, nanoparticles, etc. were developed to assess drinking water quality in a more comprehensive way than what is possible with conventional methods. These parameters were then studied along several treatment processes such as oxidation, adsorption and membrane filtration. Finally, to transfer the data from the laboratory to real world systems, a pilot plant was operated in col-

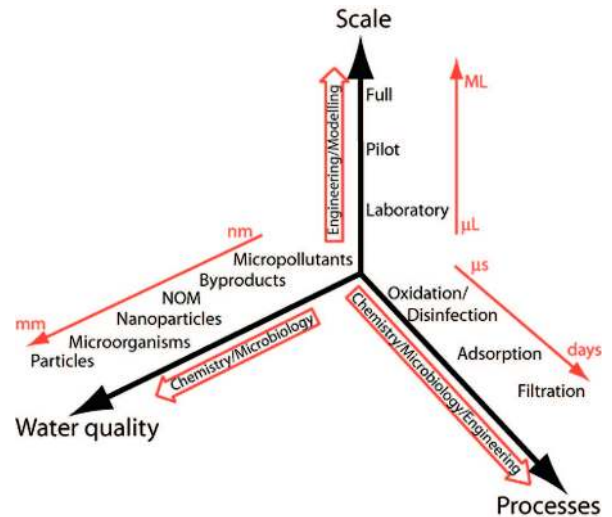

Fig. 1. Schematic overview of the Wave21 project with water quality aspects, processes and scale issues.

laboration with Water Supply Zurich (WVZ) and the engineering company Wabag to investigate up-scaling and long-term operational issues. It can also be seen in Fig. 1 that the three different disciplines mentioned above were involved at various levels of the project.

OBJECTIVES

The objectives of the project were to obtain a comprehensive understanding of drinking water quality and treatment. The following aspects were investigated:

- Standard and novel analytical methods for an integral assessment of the water quality.
- Raw water composition and its role for water treatment and finished water quality.
- Water quality along a novel treatment train including ozonation, biological activated carbon filtration and ultrafiltration.
- Up-scaling of results from laboratory investigations to pilot- and full-scale.

PROJECT STRUCTURE AND WORK PACKAGES

The topics that were investigated were defined in work packages. Five different work package focused on defining water quality parameters (summarized in the “analytical toolbox”) and three workpackages focused on processes (summarized in the “technological toolbox”). Investigations were carried out in the laboratory as well as on a pilot plant allowing combinations of unit processes. In the third part of this report, a summary of the project is provided together with an outlook and recommendations. The activities were structured as follows and will be briefly discussed here and in more detail later in the report:

1. Analytical toolbox

- 1.1. Microbiology
- 1.2. Characterisation of NOM
- 1.3. Particles
- 1.4. Taste and odor compounds
- 1.5. Micropollutants

2. Technological toolbox

- 2.1. Oxidation processes
- 2.2. Membrane technology
- 2.3. Adsorption processes

3. Outlook and recommendations

Analytical tools

As mentioned above, Eawag offers a unique infrastructure of analytical instruments, laboratory equipment and scientific know-how. New methods to measure raw water composition and water quality parameters were established as well as existing techniques improved or newly adapted for drinking water quality assessment:

- A new technique to measure ATP in biofilms was established.
- A combined method based on olfactory detection and GC-MS was developed to measure taste and odor compounds.
- Flow cytometry, was successfully adapted and established in the field of drinking water. It was applied to measure total cell count and assimilable organic carbon. In comparison with the classical plate counting methods flow cytometry showed its superiority.
- The size exclusion liquid chromatography coupled to an organic carbon detection (SEC-OCD) method was improved to better distinguish the different fractions of natural organic material (NOM).
- The newly developed method of laser induced breakdown detection (LIBD) was implemented to measure particles in the size range lower than 100 nm.

Processes

The Wave21 focus on process studies was on ozonation, activated carbon filtration and ultrafiltration. These processes were studied from the laboratory to full-scale, with a very detailed investigation on the pilot plant which was built in close collaboration with the Water Supply Zurich and the engineering company

Wabag. In the process studies water quality was assessed with regard to chemical and biological parameters by use of the newly developed analytical methods. In particular the following parameters were investigated:

- Oxidative elimination of micropollutants (emphasis on taste and odor compounds) and bromate formation during ozonation and the advanced oxidation process ozone/hydrogen peroxide.
- Transformation and removal of NOM during oxidation, activated carbon filtration and membrane filtration.
- Efficiency and aging of activated carbon filter as a biological reactor (build-up of microbiology) and adsorber for micropollutants (emphasis on taste and odor compounds).
- Fouling mechanisms of ultrafiltration membranes and optimized cleaning procedures.

These investigations are discussed in more detail below. Since the pilot plant played an important role throughout the project it is shortly described here. It integrates a pre-filtration of the raw water, an ozonation step, a granular activated carbon (GAC) filtration step and an ultrafiltration (see Fig. 2).

1. Lake Water

The intake of the raw water is located at a depth of 30 meters below the lake surface. Two pumps transport the water in a water storage tank from which the pilot plant is fed. Usually the pilot plant was run with 11.2 m³/h discharge. The maximum possible discharge was 14.0 m³/h.

2. Pre-filtration

A disc-filter was used as a pre-filter. Initially discs with 20 µm pore size were used. Because of too short backwashing intervals they were replaced by discs with 50 µm pore size. However, the pre-filter did not perform satisfactorily and therefore was removed on November 13, 2007.

3. Ozonation

The ozone contact chamber was built by two identical steel tanks which could either be operated in parallel or in series. This allowed both, large discharge (parallel) and long contact times (in series). Each tank was divided into four compartments (see Fig. 2). In order to achieve plug-flow conditions in the four compartments, obstacles were integrated in the contact chamber. The design and placement of these obstacles was calculated by computational fluid dynamics (CFD) modelling. Each contact chamber provides four sampling points. The locations of the sampling points are indicated in Fig. 2.

In the middle of the contact chamber, between compartment 2 and 3, a possibility for hydrogen peroxide injection was implemented to perform experiments with the advanced oxidation process ozone/hydrogen peroxide. The amount of ozone injected in the contact chamber was either fixed or regulated according to the desired residual ozone concentration at the effluent of the chamber.

4. Granular activated carbon filter (GAC)

The GAC filter consisted of two identical filter columns. Each column had a total height of 265 cm whereas the filter bed was only 150 cm high. The column above the filter bed was filled with water. The dimensions of the filter columns were designed for a contact time of 15–20 min. Each column provided 24 sampling points for water samples. The first one was 5 cm above the bottom and all others 10 cm apart from each other. The numbering of the sampling points started at the bottom of the filter column. Water samples were mainly taken at P4, P8, P12 and P15 (see Fig. 2).

P15 (145 cm above bottom) was the last sampling point in the filter bed (5 cm below the water filter bed boundary). At four levels it was possible to take solid samples of the GAC. The first point was 40 cm above the bottom of the column and the others 35 cm apart from each other (see Fig. 2). The two GAC filter columns allowed two different operating regimes at the same time. The first column (M265 in Fig. 2) was backwashed regularly from the beginning of its operation, whereas the second column (M266 in Fig. 2) was not backwashed until May 2007 (235 days of operation). The dimensions of the filter columns and the locations of the sampling points are shown in Fig. 2.

5. Membrane filtration

In the first phase (October 2006 until January 2008) a submerged Zeeweed hollow fiber membrane from Zenon with a pore size of around 20 nm was used. From January 2008 onwards a pressure-driven hollow fiber membrane from Inge AG with a pore size of 20 nm was installed. From January 2008 onward the submerged membrane (Zeeweed) was fed directly with raw water. Both membranes were designed for a discharge of 3.3 m³/h. The remaining discharge of approximately 7.9 m³/h was diverted either directly back to the lake, or during the experimental phases into the sewage system.

The pilot plant was also monitored continuously with a system of online sensors measuring discharge, temperature, turbidity, particle size, pH, ozone concentration, oxygen concentration, etc.. The data were collected in intervals of seconds, if necessary corrected and stored as 10 min averages. This system was mainly maintained by the engineering company Wabag and the WVZ. Additionally, phytoplankton was measured in the laboratory in intervals of 3 to 14 days. These data were used to correlate changes in the operating regime of the pilot plant with water quality parameters and vice versa. A detailed report on the operation and maintenance will be available from the Water Supply Zurich.

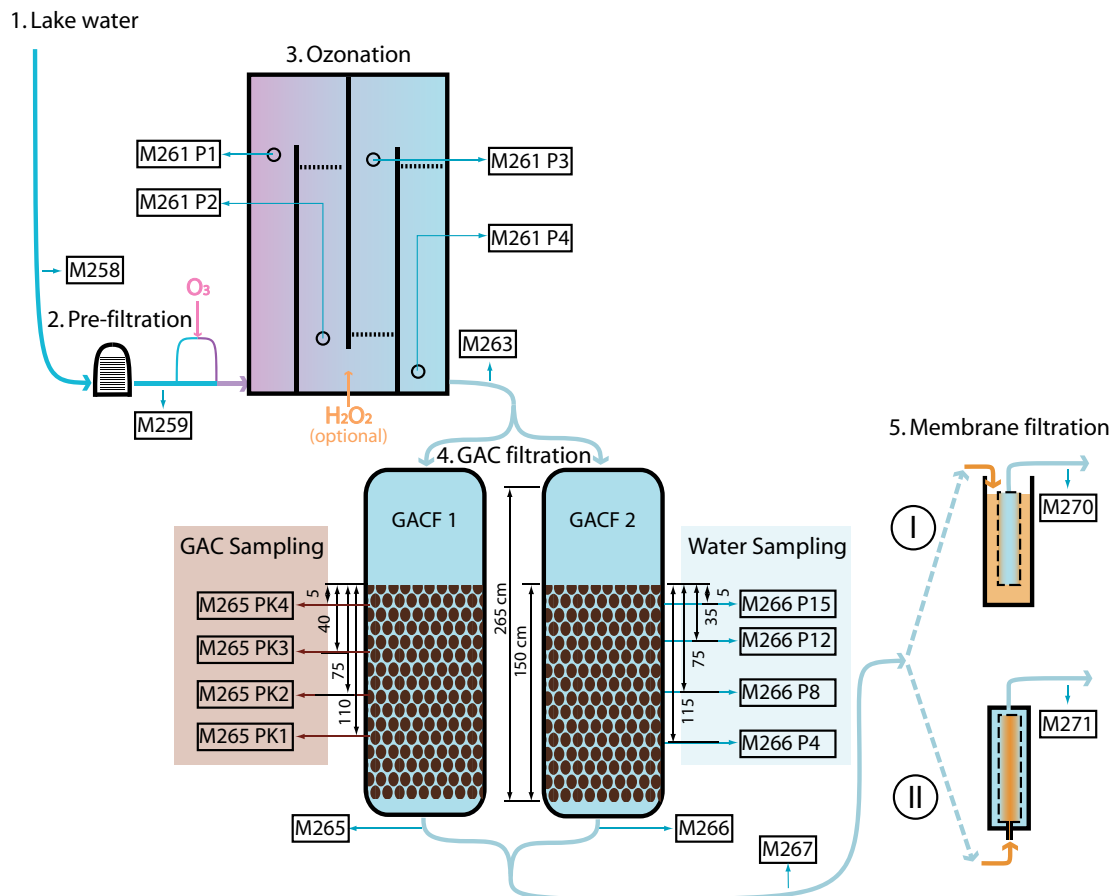

Fig. 2. Plan of pilot plant with sampling points. Description of each sampling point is given in Table 1. Both GAC filters were equipped with sampling points for solid GAC samples (PK1 to PK4) and sampling points for liquid water samples (P1 to P15), even if the dimensions are only given for one filter separately. Water sampling points were available every 10 cm (P1 to P15). Only the sampling points that were most frequently used are shown.

Table 1. Description of sampling points.

Sampling point	Location in the treatment train	Comment
M258	Raw water from Lake Zurich	
M259	Pre-filtered water (PF)	The pre-filter was operated until November 2007
M263	After the ozonation	
M265	Effluent water of GAC filter column 1	Filter 1 was backwashed during the entire duration of operation
M265 P15–P4	Water sampling points GAC filter column 1 (P15: 5 cm, P12: 35 cm, P8: 75 cm and P4: 115 cm immersion depth)	
M265 PK1–PK4	Solid GAC sampling points GAC filter column 1 (PK4: 5 cm, PK3: 40 cm, PK2: 75 cm, PK1: 110 cm immersion depth)	
M266	Effluent water of GAC filter column 2	Filter 2 was not back washed for the first 235 days of operation
M266 P15–P4	Water sampling points GAC filter column 2 (P15: 5 cm, P12: 35 cm, P8: 75 cm and P4: 115 cm immersion depth)	
M266 PK1–PK4	Solid GAC sampling points GAC filter column 2 (PK4: 5 cm, PK3: 40 cm, PK2: 75 cm, PK1: 110 cm immersion depth)	
M267	Feed water for the membrane filtration (combined water from both GAC filter effluents).	
M270	Permeate of the submerged membrane system	The submerged membrane was operated from October 2006 until December 2007
M271	Permeate of the pressurized membrane system	The pressurized membrane was operated from January to September 2008.

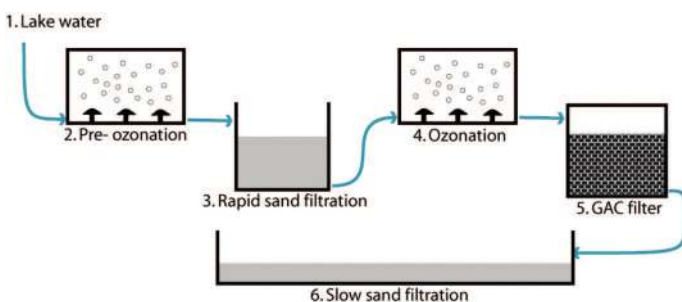

Fig. 3. Schematic representation of the full-scale treatment plant Zurich Lengg.

Full-scale plant

The full-scale treatment plant at the water works Lengg uses the identical raw water as the pilot plant. The classical multi-barrier treatment train comprises a pre-ozonation, rapid sand filtration, ozonation, GAC filtration and a slow sand filtration (see Fig. 3). There are sampling points after each treatment step. The setup of two treatment systems using the same raw water allowed a direct comparison of the alternative treatment trains. The data of the full-scale plant were mainly used to compare the effluent of the slow sand filter with the effluent of the ultrafiltration. An important aspect was the comparison of the biological stability of the two effluents.

1 ANALYTICAL TOOLBOX

1.1 MICROBIOLOGY

INTRODUCTION

Drinking water microbiology has for more than 100 years been dominated by a conservative approach caused by a limited understanding of the indigenous bacterial flora, its function and related processes in treatment and distribution systems. This was mainly due to the lack of sensitive, fast and realistic methods to detect and quantify both the indigenous microbial cells and the presence of relevant pathogens. For the past time, routine monitoring and hygiene assessment focused on the detection of (1) cultivable heterotrophic microbes as a measure of the general microbiological quality of (drinking) water, and (2) the detection of indicators for faecal pollution using plating methods. This is clearly evidenced by the current Swiss legislation, which requires the measurement of only three microbiological parameters, namely heterotrophic plate counts (HPC) and the two bacterial indicators *Escherichia coli* and *Enterococcus* spp.. This situation is similar to the rest of Europe and other industrialized countries.

Nonetheless, microbiology plays a key role in functional processes (e.g. organic carbon removal) as well as typical water problems (e.g. regrowth, biofilm formation, hygiene and pathogen growth). In the microbiological part of the Wave21 project, we aimed to establish a new approach to the assessment of bacteria in drinking water and the conceptual focus was placed on understanding growth and behaviour of the microbial flora in treatment and distribution systems. Growth under these conditions differ fundamentally from conventional studies of microbial growth, as the drinking water environment is dominated by extremely low concentrations of organic carbon and thus low concentrations of bacteria. During the past 30 years it has become evident that in samples from fresh-, seawater and soil only a small fraction of the total microbial flora detected by microscopy can be cultivated on agar plates, a phenomenon referred to as "the great plate count anomaly". Conventional methods, particularly the HPC method, are therefore not suited for the analysis of bacteria and bacterial growth under such conditions.

Hence, a key aspect of the project was the development of a set of methods/tools with which bacteria, and the nutrients that are consumed by bacteria, could be measured accurately and fast, and to apply these methods on full-scale systems. In all methods developed the application of flow cytometry (FCM) was instrumental and, therefore, will be presented shortly. FCM is an established method in medical routine analysis for detecting cells (e.g. in blood) quickly and reliably. Numerous dyes for staining cells have been developed for medical applications and within the last decade standard instruments have become sensitive enough for routine detection of small bacterial cells. Generally, detection of microbial cells by FCM is achieved after staining cells with a fluorescent dye that binds to a specific target and the subsequent detection of the laser-induced fluorescence sig-

nal (Fig. 4). The method offers several advantages compared to standard microbiological methods such as:

- Detection of all cells present in a sample, alive and dead.
- Detection of cells that cannot be cultivated on plates.
- Detection of active cells after staining with specific activity stains.
- Detection of specific microbes after staining with surface-binding fluorescent antibodies.
- Counts up to 1000 cells/sec (some machines up to 100'000 cells/sec).

For example, a total cell count in a water sample can be done within 15 minutes, including staining and detection; the high number of cells that can be counted within a short time results in an improved standard deviation (SD) of <5% compared to conventional methods such as microscopy counting, plate counts, or the most probable number technique (typical SD > 10%).

OBJECTIVES

Within this work package we had the goal to develop fast and reliable methods for the following purposes:

- 1) A method for the quantification of the total bacterial cell number in a water sample, irrespective of whether or not they can be plated.
- 2) A method for quantifying the fraction of "viable"/active microbial cells.
- 3) An assay for the quantification of the fraction of the total dissolved organic carbon that can be used by microbes for growth, the so-called "assimilable organic carbon" (AOC).
- 4) An ATP-based assay to quantify bacterial biomass on solid particles.

A further point, which was originally included in the plan, was an attempt to develop an assay for the detection of the total number of viruses in drinking water. Progress on the latter point was unfortunately hampered because no accurate quantitative tool for virus analysis was available. Two separate attempts were launched to make virus detection work in combination with flow cytometry, but up to date this has not been successful.

The four areas that were successfully established are summarized below:

(1) *Total bacterial cell count based on flow cytometry:* There are significantly higher numbers of microbial cells in drinking water than what can be cultured on synthetic growth media. Nonetheless, cultivation-based heterotrophic plate counts (HPC) are used world wide as a general microbial quality parameter in drinking water treatment and distribution systems. Total bacterial cell concentrations (determined for example with microscopy) are normally not considered during drinking water treatment as either design, operative or legislative parameter. A proper understanding of microbial survival and growth during drinking water treatment and distribution starts with the ability to quantify all the microorganisms accurately and rapidly. As flow

cytometry allows quantification of microbial cells rapidly after staining with a variety of commercially available dyes, most of them originally developed for fluorescence microscopy, we developed a method for the fast, cheap and accurate enumeration of bacterial cells in surface, ground and drinking water.

(2) *Assessment of viability/activity of bacterial cells:* Some 90–99%, or even more, of the bacterial cells detected in aqueous and terrestrial environments cannot be cultivated in the laboratory with the methods presently used. This huge discrepancy between cultivable and total cell counts has been known for a considerable time and is commonly referred to as “the great plate count anomaly”. This raises the question of the viability and activity of the fraction of non-cultivable bacterial cells but detected by either microscopy or flow cytometry. Recently, flow cytometry coupled with viability-indicating stains was shown to be useful to characterize the physiological states of pure cultures in biotechnological processes. However, these stains have only reluctantly been applied to natural communities in drinking water samples. We have therefore investigated whether or not a group of viability-indicating stains can be used for rapid, cultivation-independent detection of the fraction of active cells in drinking water samples; subsequently, we have tested whether such a method can be applied to the rapid detection of treatment process failure in the drinking water production train.

(3) *AOC:* Only a small fraction of the total organic carbon (TOC) in drinking water is utilisable by bacteria. However, this fraction is of particular interest for drinking water researchers and practitioners, since unwanted degradation of these compounds will lead directly to the proliferation of bacteria in treatment and distribution systems. Undesired bacterial growth has known risks/problems, such as biofilm formation and biofouling with the associated problems (e.g., taste and odour issues, (bio)corrosion, turbidity, etc.). This is of particular importance in several European countries including Switzerland where either no post-treatment disinfection is applied, or where no disinfectant residual is present in the water. AOC is measured with a bioassay that quantifies the batch growth of bacteria in a drinking water sample. The original method based on standard strains and plating (more than 20 years old) has often been deemed too time consuming (analysis requires 14 days) and labour intensive. The FCM-based method developed here allows not only the determination of AOC concentrations in water samples within 3 days but also the easy handling of a large number of samples simultaneously.

(4) *ATP on granular activated carbon (GAC) particles:* Granular activated carbon (GAC) filters are commonly used in drinking water treatment for the removal of dissolved organic carbon (DOC) and micro-pollutants (MP) such as pharmaceuticals, halogenated hydrocarbons and taste and odour (T&O) compounds, or for the removal of biodegradable organic carbon fractions. Some water works (e.g. WVZ) use the GAC over an extended time period (up to 20 years), where the ultimate focus shifts from an adsorption process towards a biological process for the removal of organic carbon. To understand the processes of these

filters, it is imperative to quantify the microbiology accurately. No method that was available seemed to address this problem satisfactorily. Hence, we initiated the development of a new method to determine the active biomass on GAC based on quantification of the ATP on GAC particles. For calibration of the method flow cytometry was also employed (see below). This links directly to the work in work package 2.3 and also to the studies on the Wave21 pilot plant.

RESULTS AND DISCUSSION

Total bacterial cell count based on flow cytometry

We have optimised the flow cytometric method for total cell counting at low cell concentrations and demonstrated the value of this application in describing a drinking water treatment and distribution system (Hammes et al., 2008; Siebel et al., 2008). The method based on the fluorescent labelling of nucleic acids in bacteria is simple and fast (see Fig. 4). One of the key advantages is that it allows the detection of all bacterial cells in a water sample. This is essential, since the conventional HPC method detects only about 1% of all bacterial cells. Hence, the flow cytometric method allows for a much more comprehensive assessment of general microbial quality and specific microbial processes. The method was also tested in the full-scale plant of

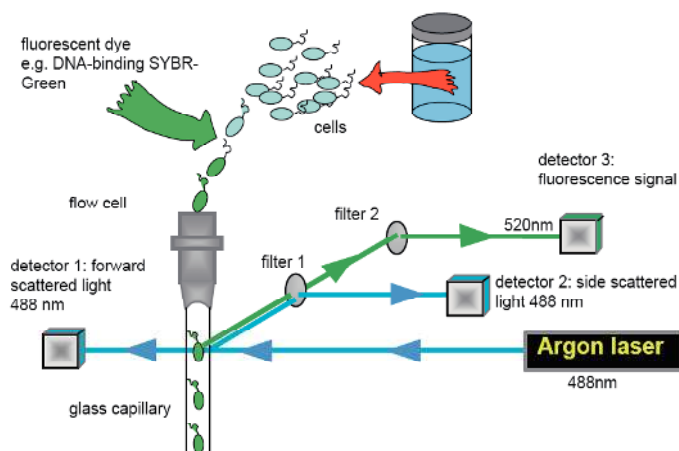

Fig. 4. The basic principle of flow cytometric detection of cells after staining with a specific (e.g. DNA-binding) fluorescent dye.

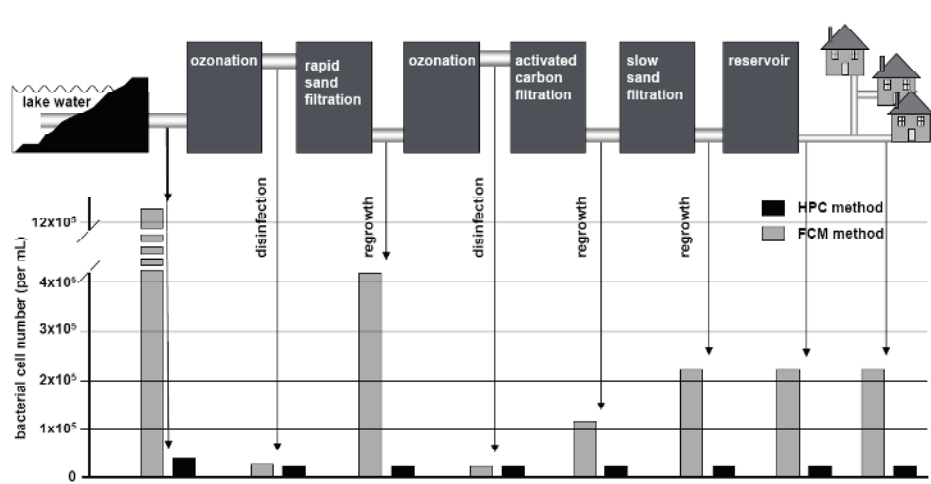

Fig. 5. The presence of bacterial cells assessed with either flow cytometry or plating (HPC) in a drinking water treatment and distribution system (city of Zurich). The cultivation method underestimates the number of cells present by roughly two orders of magnitude. The flow cytometry total cell count method allows quantifying conveniently the effects of filtration, disinfection, and re-growth in the treatment train and distribution system. Adapted from Egli et al. 2008.

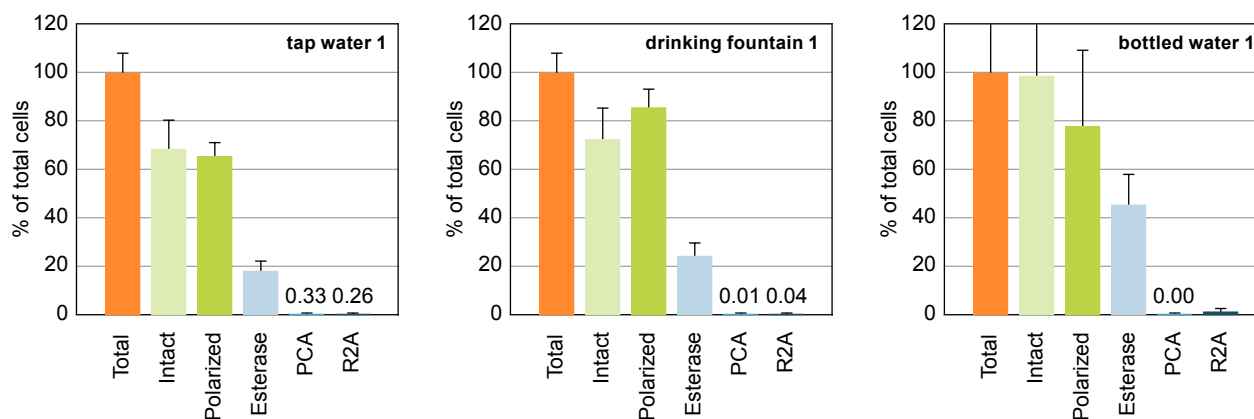

Fig. 6. Comparison of established cultivation-dependent and new cultivation-independent viability indicators determined in tap water, a sample from a public drinking water fountain in the city of Zurich, and commercially sold bottled water. Cultivation-dependent methods included plating on PCA and R2A agar plates, cultivation-independent methods were measured by flow cytometry using fluorescent stains and included the total cell number, intact cells, cells with a membrane potential (polarized) and esterase activity. Error bars represent standard deviations of triplicate measurements. The stains used were Sybr Green (SG for total cell count), propidium iodide (PI, staining cells with a disrupted cytoplasmic membrane), DiBaC, indicating cells that still were “polarized”, i. e. exhibited a membrane potential, and CFDA, indicating activity of esterase in a cell. Adapted from Berney et al., 2008.

Leng in collaboration with WVZ (Fig. 5; Hammes et al., in preparation), where it was demonstrated that the different treatment processes can be described accurately with this method. Furthermore, we found a special application of the flow cytometry method in the characterisation of filterable bacteria (Wang et al., 2007; 2008), the characterisation of a specific group of “low nucleic acid bacteria (LNA)” in drinking water (Wang et al., 2009), as well as to monitor pathogen growth in freshwater (Vital et al., 2007; 2008).

Assessment of viability/activity of bacterial cells

The second step in the flow cytometry methods was the development of specific methods for the analysis of viability in bacterial cells. This is especially significant in treatment and distribution systems where disinfection processes are used. Viability analysis is more challenging than total cell counts because no

single fluorescent stain is on its own an accurate indicator of viability and also because natural microbial communities react differently to different stains. Nonetheless, an array of stains, best used in concert, has been developed and tested on drinking water in and around Zurich, including bottled drinking water from different brands, tap waters and public fountains (Berney et al., 2007; 2008). The results suggest that usually between 60–80 % of all bacterial cells detected with flow cytometry are active in drinking water (an example is given in Fig. 6).

Development of a novel AOC assay

During the first phase of the project we have developed a new AOC assay (Hammes and Egli, 2005). This new method uses the same principles of the conventional AOC assay, namely quantification of growth of bacteria in a water sample. The concentration of bacteria that grows up in a given water sample re-

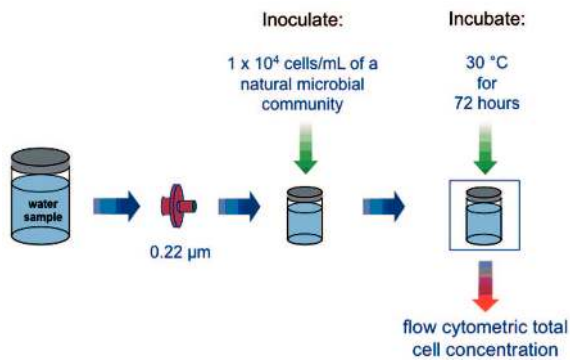

Fig. 7. The basic steps in the new AOC method.

lates to the concentration of organic carbon that is assimilated during growth. The main differences to the original AOC method is that a natural microbial community is introduced as an inoculum, providing a broader substrate range than what can be achieved with pure cultures, an elevated assay temperature of 30 °C compared to 15 °C in the old assay, and detection of the growth of microbial cells with fluorescent staining of the cells and enumeration with flow cytometry (Fig. 7). The advantages of the new AOC method compared to existing methods are that it is fast (2–3 days compared to 14 days) and it allows a large number of samples to be processed (up to 30 samples in triplicate per day can be handled by one person).

The method was tested extensively within the Wave21 project to assess the formation of AOC during ozonation in the absence and presence of algal cells (Hammes et al., 2006; 2007). A direct link to Wave21 work package 1.2 and work package 2.2 was established, where the AOC assay in the context of membrane filtration was assessed (Meylan et al., 2007), with the main finding that most AOC-like molecules pass through nanofiltration membranes. The method has also led to new research areas at Eawag, namely the field of pathogen growth in freshwater (Vital et al., 2007; 2008), a project on the presence of filter-

able bacteria in water (Wang et al., 2007; 2008), and a project on bacterial growth in bottled drinking water (Wang et al., 2008). Furthermore, it has been applied during an 18-months period on water samples from the full-scale plant Lengg in a collaborative project with the Water Supply Zurich (Hammes et al., in preparation). Based on this project the Water Supply Zurich decided to acquire this technology and incorporate it as an additional microbiological parameter in their routine analysis.

The AOC assay is currently being tested on water samples from different water works in the framework of the European Project TECHNEAU. In addition, an ongoing project from AWWARF/Eawag is comparing different AOC assays, which would allow for the direct comparison of data generated by different methods. Finally, a new project on the migration of biodegradable components from plastic surfaces such as drinking water pipes, makes use of the basic principles of the newly developed AOC assay.

Development of ATP analysis for biomass characterisation in GAC filters

We have developed a fast and direct assay to measure the concentration of ATP on GAC particles and we have combined this assay with flow cytometry (below) to estimate the concentration of bacterial cells from the concentration of ATP (Velten et al., 2007). In this method, ATP is extracted directly from cells attached to the GAC particles and then measured with the luciferin-luciferase assay (Fig. 8). This new method was first tested on a small-scale pilot filter and then transferred to the Lengg pilot plant (Velten et al., in preparation). One of the key findings from the latter study was that stratification occurs in GAC filters treating drinking water. This demonstrated the need for further understanding of the functional microbial communities in drinking water treatment plants. The method was further combined with molecular analysis of the microbial communities in the GAC reactor in a collaborative project with Gent University, Belgium (Boon et al., 2008). In addition, the method was in the mean

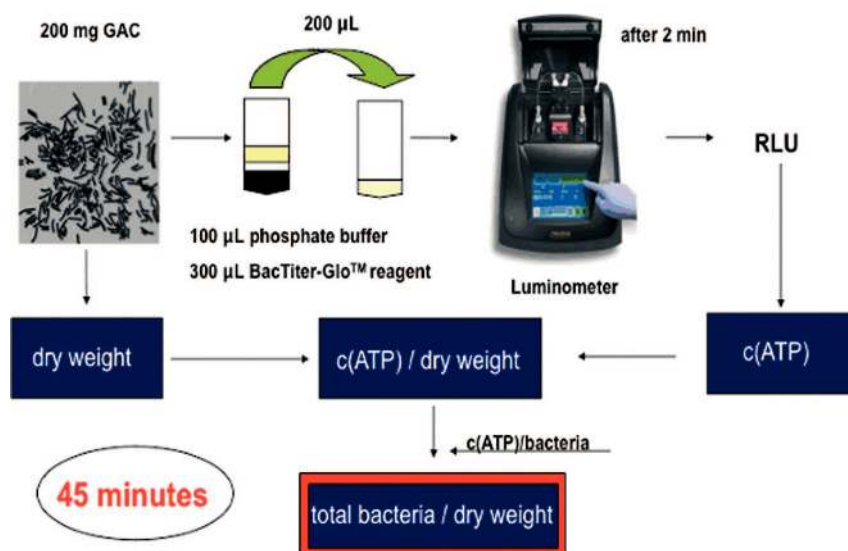

Fig. 8. The basic steps of the ATP-GAC method (from Velten et al. 2007). RLU: relative light units; c(ATP): concentration of ATP.

time adapted for analysis of biomass on sand (for characterisation of rapid and slow sand filters) and for the analysis of biofouling on membrane layers.

In a new study the method will be used to quantify the biomass on all the different biological filters in a full-scale plant (Lengg) in order to make a complete mass balance of organic carbon removal and biomass production. This study has also prompted the need for more detailed investigations into biodegradable organic carbon (BDOC) fractions in drinking water and lab-scale reactors for this purpose have already been initiated.

Flow cytometry and its potential in drinking water analysis

The potential of flow cytometry as a tool for microbial analysis of drinking water is immense. We have clearly demonstrated that the most basic application, i.e. total cell counting, is already superior to conventional analysis methods such as heterotrophic plate counts in that it is much faster and more descriptive of the changes in microbial abundance during treatment and distribution. Moreover, the development of methods to monitor microbial viability will allow a better assessment of disinfection processes than was previously possible. In addition, the basic principles of the method are currently being expanded in our group towards the rapid screening for specific microbial pathogens in drinking water.

Sensitive, simple and less expensive types of flow cytometers are already available which are perfectly suited for analysis of drinking water. If the development of smaller and cheaper hardware continues, analysis of a range of microbiological safety parameters appears to be possible, even on-line analysis appears to be in not too distant future.

WAVE21 PUBLICATIONS RELEVANT FOR THIS WORK PACKAGE

- Berney M., Hammes F., Bosshard F., Weilenmann H.U., Egli T. (2007) Assessment and interpretation of bacterial viability by using the LIVE/DEAD BacLight Kit in combination with flow cytometry. *Applied and Environmental Microbiology* 73, 3283–3290.
- Berney M., Vital M., Hülshoff I., Weilenmann H.U., Egli T., Hammes F. (2008). Rapid, cultivation-independent assessment of microbial viability in drinking water. *Water Research* 42, 4010–4018.
- Boon N., Wittebolle L., Velten S., Traber J., Köster O., Hammes F. (2008) Stratification in a granular activated carbon reactor determines microbial community composition, dynamics and activity. 12th International Symposium on Microbial Ecology. Cairns, Australia, August 17–22, 2008.
- Egli T., Berney M., Hammes F., Fuchsli H.P. (2008). Neue Methoden zur Beurteilung der Trinkwasserhygiene. *Eawag-News* 65d, 20–23.
- Hammes F., Egli T. (2005) New method for assimilable organic carbon determination using flow-cytometric enumeration and a natural microbial consortium as inoculum. *Environmental Science and Technology* 39, 3289–3294.
- Hammes F., Berney M., Wang Y., Vital M., Köster O., Egli T. (2008) Flow-cytometric total bacterial cell counts as a descriptive microbiological parameter for drinking water treatment processes. *Water Research* 42, 269–277.
- Hammes F., Meylan, S., Salhi, E., Köster, O., Egli, T., von Gunten, U. (2007) Formation of assimilable organic carbon (AOC) and specific natural organic matter (NOM) fractions during ozonation of phytoplankton. *Water Research* 41, 1447–1454.
- Hammes F., Salhi, E., Köster, O., Kaiser, H.P., Egli, T., von Gunten, U. (2006) Mechanistic and kinetic evaluation of organic disinfection by-product and assimilable organic carbon (AOC) formation during the ozonation of drinking water. *Water Research* 40, 2275–2286.
- Hammes F., Berger C., Köster O., Egli T. (in preparation) Biological stability of drinking water without disinfectant residuals: a case-study of the Zurich water supply system.
- Siebel, E., Wang, Y., Egli, T., Hammes, F. (2008) Correlations between total cell concentration, total adenosine tri-phosphate concentration and heterotrophic plate counts during microbial monitoring of drinking water. *Drinking Water Engineering and Science* 1, 1–6.
- Velten S., Hammes F., Boller M., Egli T. (2007) Rapid and direct estimation of active biomass on granular activated carbon through adenosine tri-phosphate (ATP) determination. *Water Research* 41, 1973–1983.
- Velten S., Hammes F., Boller M., Egli T. (2007). ATP Measurement as a means for directly estimating active biomass. *PROMEGA notes*, Number 97, 15–17.
- Velten S., Hammes F., et al. (in preparation) Biomass development and stratification during the start-up phase of a granular activated carbon (GAC) filter.
- Vital M., Hammes F., Egli T. (2008). E. coli O157 can grow in natural freshwater at low carbon concentrations. *Environmental Microbiology* 10, 2387–2396.
- Wang, Y., Hammes, F., Boon, N., Egli, T. (2007). Quantification of the filterability of freshwater bacteria through 0.45, 0.22, and 0.1 micrometer pore size filters and shape-dependent enrichment of filterable bacterial communities. *Environmental Science and Technology*, 41(20):7080–7086.
- Wang Y. (2008) “The unseen majority”: Heterotrophic bacteria in freshwater. More than just small and non-cultivable. Doctoral dissertation, Swiss Federal Institute of Technology, Zurich, Switzerland, ETH-Nr. 17894.
- Wang Y., Hammes F., Duggelin M., Egli T. (2008) Influence of size, shape and flexibility on bacterial passage through micropore membrane filters. *Environmental Science and Technology* 42, 6749–6754.
- Wang Y., Hammes F., Boon N., Chami M., Egli T. (2009). Cultivation, isolation and characterization of low nucleic acid (LNA) content bacteria from various freshwater environments. *Microbial Ecology online*.

1.2 CHARACTERISATION OF NOM

INTRODUCTION

The decomposition of plant, animal and microbial material in soil and water produces a variety of complex organic molecules, collectively called natural organic matter (NOM). NOM can impair water treatment processes. For example, low-molecular weight NOM is used as a substrate for microbial growth or re-growth and can thus produce a biologically instable water (see work package 1.1). In addition, NOM can influence oxidation and disinfection processes (e.g. efficiency, formation of oxidation by-products, etc., see work package 2.1) and play an important role in adsorption processes (reduction of micro-pollutant adsorption capacity, see work packages 1.5 and 2.3) and membrane fouling (see work package 2.2).

Several analytical tools are available for characterization of NOM. In the Wave21 project a fast method was required for the determination of NOM composition, giving relatively straightforward information on the composition of NOM. After an extensive selection process, the method of Size Exclusion Liquid Chromatography coupled to Organic Carbon Detection (SEC-OCD) was selected for this purpose. In a later stage the method was extended with an Organic Nitrogen Detection (OND).

SEC-OCD-OND

In the SEC-OCD-OND system the NOM is separated in five fractions according to their size and chemical behavior. The size exclusion column (Toyopearl TSK HW 50S) separates the hydrophilic dissolved organic matter (CDOC) in a molecular range between 20'000 D and 100 D. CDOC is quantified in a special "Graentzel" Thin-Film-Reactor (TFR), where a complete oxidation of the separated fractions to CO₂ takes place which is quantified by an infrared detector. After the oxidation in the TFR the fractions then pass a UV-Detector (@220nm) which quantifies the organic Nitrogen (OND). In parallel, an online UV-Detector (@254 nm UVD) is used which gives information on the aromaticity. The SEC-OCD fractions are shown schematically in Figs. 9 and 10.

The *biopolymer* fraction is often also designated as *polysaccharide* fraction. It actually contains all polymeric (> 20kD) and colloidal material, and includes mainly polysaccharides and proteins. *Humics* have a molecular weight of around 1 kD and correspond to 50–60% of the CDOC. *Building blocks* are mainly degradation products of humics and have a molecular weight of 300–500D. The *low molecular weight (LMW-) acids* (mono- and dicarboxylic-acids) and the *LMW humics* elute at the same time in one peak and are also called *LMW organics*. Their molecular weight is less than 350D. *Neutrals* are defined as a mixture of neutral and amphiphilic compounds and their molecular weight is also <350D. Because of their partial hydrophobic character they elute latest.

The difference between total organic carbon (TOC) and dissolved organic carbon (DOC) corresponds with the particulate organic carbon (POC). Only hydrophilic DOC (CDOC) can be

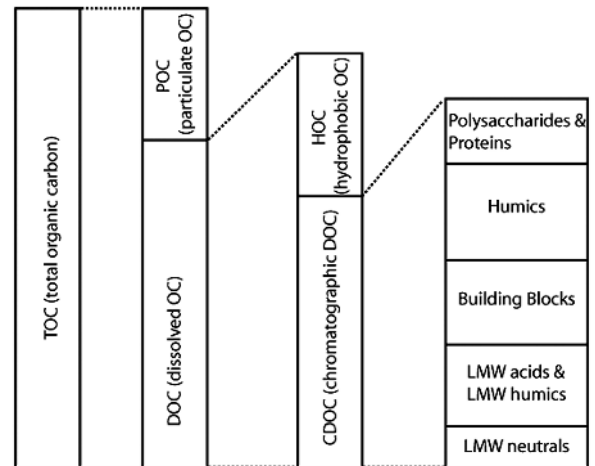

Fig. 9. Breakdown of TOC in fractions which can be analysed by SEC-OCD (after Huber and Frimmel, 1992a,b).

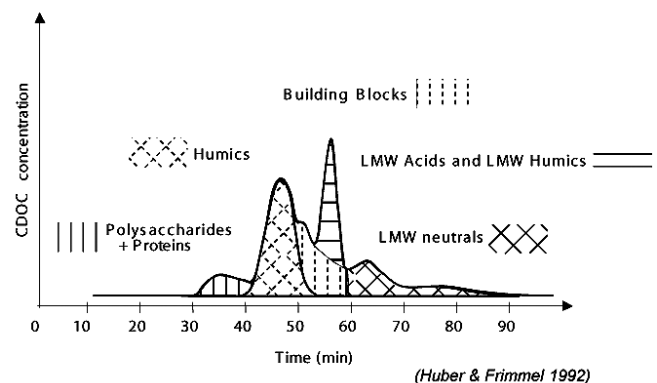

Fig. 10. The 5 separable fractions of NOM. A higher retention time corresponds to a lower molecular weight.

separated by the SEC-Column in these 5 fractions; the hydrophobic part (HOC) remains on the column and is calculated as the difference between the DOC and CDOC.

OBJECTIVES

NOM characterization by SEC-OCD was used to investigate the following aspects relevant for drinking water treatment:

- Seasonal pattern of NOM fractions in lake water.
- The role of various NOM fractions in different water treatment processes and removal/transformation of NOM.

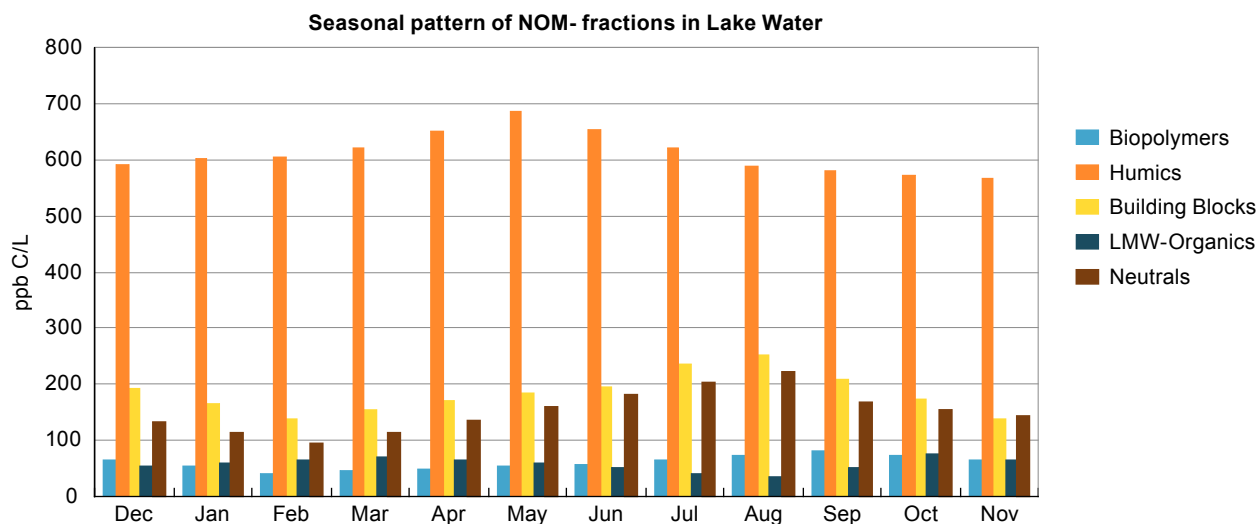

Fig. 11. Seasonal changes in NOM-fractions in the Lenggr raw water taken from Lake Zurich (at a depth of 30 m).

RESULTS AND DISCUSSION

Seasonal patterns of NOM in lake Zurich water

As Lake Zurich water is relatively clean, the highest DOC concentration during the whole pilot study was 1323 ppb C/L (Table 2).

Over the year, the DOC value of the lake water at 30m depth changes within a relatively small range. The highest changes in relative concentrations were seen in the biopolymer, neutrals and in the LMW humics-fractions and are around 100–130%. Absolutely, the neutrals vary between about 220 ppb C/L and 100 ppb C/L, the LMW-humics between about 80 ppb C/L and 30 ppb C/L, and the biopolymers between 70 ppb C/L and 40 ppb C/L. The variation of building blocks (80%) is smaller and the change of humics (17%) almost insignificant. Building blocks vary between about 250 ppb C/L and 140 ppb C/L and humics between 690 and 570 ppb C/L during the year (Fig. 11).

The results in Fig. 11 can be qualitatively interpreted as follows:

In *winter* when the bacterial and algal activity is low the highest molecular weight fraction (biopolymers) is further reduced, probably by remaining cellular or enzymatic activity (hydrolysis).

In *summer* with raising temperature and sunlight the microbial and algal growth and activity increases towards a maximum. This causes an increase of the LMW compounds. Humics are partially degraded, resulting in an increase in building blocks. Biopolymers (polysaccharides and proteins) are increasing in spring and summer. This can be caused by microbial excretion of EPS (Extracellular Polymeric Substances) or by degradation of plant material.

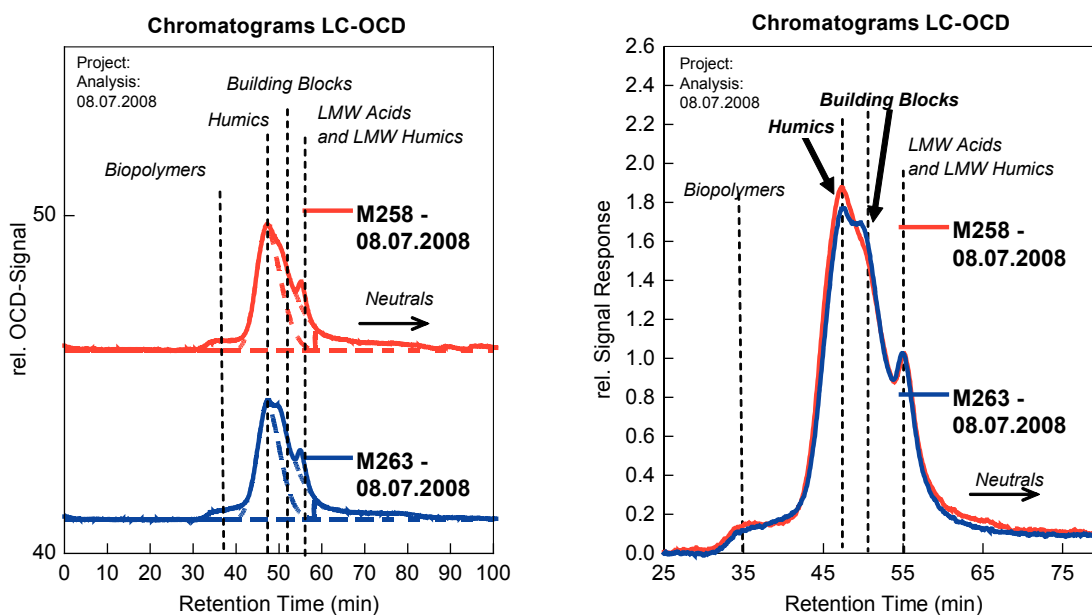

Fig. 12. LC-OCD Chromatographs for raw water (M258) and water after ozonation (M263). Left side: fractions, right side: overlay of curves.

Changes in NOM-fractions during the different water treatment steps in the Lengg pilot plant

Prefiltration

No influence on NOM-fractions could be observed.

Ozonation

Fig. 12 shows LC-OCD chromatograms of raw water (M258) and ozonated water (M263). Higher molecular weight compounds (humics) are transformed by ozone to lower molecular weight compounds (building blocks, LMW humics). Table 2 shows the quantification of the NOM-fractions of these two water samples. The amount of humics decreases and building blocks and LMW humics increase simultaneously. The ratio of UV adsorption (254 nm) to DOC is defined as SUVA (specific UV adsorption) and defines the relative aromaticity in the fraction. It was found that the SUVA of humics is about 40% lower in the ozonated sample (M263) as compared to the raw water (M258), (see Table 2). This can be explained by the fact that ozone reacts rapidly with conjugated systems.

Granular Activated Carbon Filters (GAC Filters)

Fig. 13 shows the SEC-OCD chromatograms of the four sampling levels in GAC Filter M266 during the start-up phase. During this phase, all NOM fractions, except the biopolymers, decrease from top to bottom of the filter in the flow direction of the water (P15 towards P4). As the biological activity of the filter is still negligible, removal takes place mainly by adsorption during this phase. The ratio of humics at sampling point P15 to humics at sampling point P4 is around 10, indicating about 90% removal of this fraction. The fact that biopolymers are not removed can be explained by their high molecular weight, preventing them from entering the GAC pores.

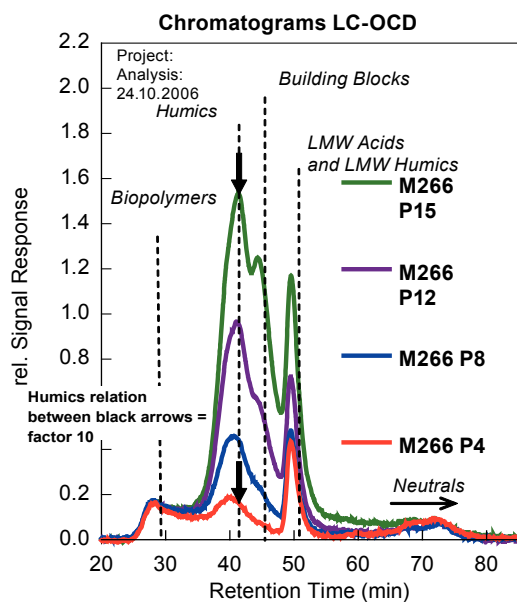

Fig. 13. LC-OCD chromatograms of four sampling points at different heights in the activated carbon filter GAC-2 (M266, P15: 5 cm; P12: 35 cm; P8: 75 cm; P4: 115 cm intrusion from the top of the carbon layer; (see Fig. 2 for details)) during the start-up phase of the filter.

Fig. 14 shows the LC-OCD chromatograms of the same four sampling-levels in M266 after five months of operation. The ratio of the humics fraction in sample P15 to sample P4 amounts to 1.1, which indicates a slight decrease (9.1%) along the length of the filter. Also building blocks and the low-MW fractions are still removed to some extent. However, no significant removal of the biopolymer fraction occurs. The decrease of the removal with operation time can be explained by saturation of the filter and pore-blocking by smaller NOM compounds (<5kD) resulting in a steady decrease of adsorption capacity. Simultaneously, however, the biology in the filter develops, resulting in some removal of lower-MW fractions (see work package 1.1 and work package 2.3). From the present results it can not be derived which part is removed by adsorption and which part is removed by biological activity. As the biopolymer fraction is not removed during start-up and after five months, it can be concluded that this fraction is neither adsorbable nor biodegradable in the GAC-filter (see work package 2.3).

The DOC concentration in sample P15 is somewhat higher than in the feed water sample. This can be explained as follows: As the GAC-filters were not filled up to the top, the water standing on the GAC filter bed still contains a certain ozone residual concentration. Ozone can result in destroying and lysis of the biomass retained in the upper layer on the filter-bed, leading to release of organic material.

Membrane Filtration (Ultrafiltration)

The ultrafiltration (UF) membranes used in the pilot plant with a cut-off of 100-200 kD cause only partial retention of the biopolymer fraction (>20'000 D). All other fractions were not retained substantially due to their low molecular-weight (< 1000 D). The UF treatment decreases the biopolymer fraction to 20–50 % de-

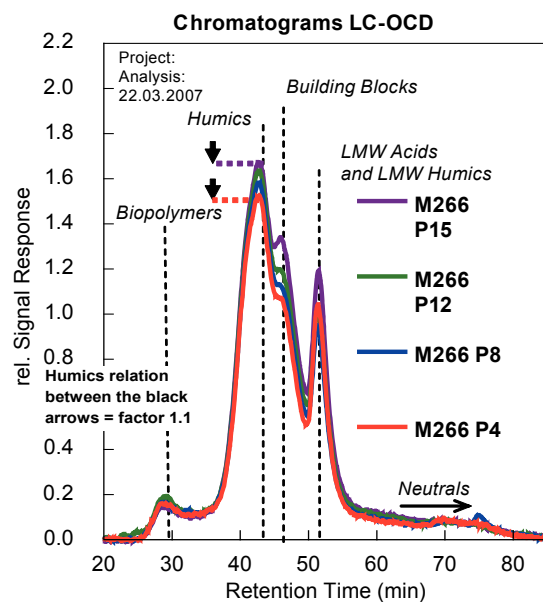

Fig. 14. LC-OCD chromatograms of the same 4 sampling levels of GAC-2 (M266, P15: 5 cm; P12: 35 cm; P8: 75 cm; P4: 115 cm intrusion from the top of the carbon layer (see Fig. 2 for details)); after 5 months of operation.

Table 2. Quantified NOM-fractions of Lake Zurich raw water (M258) with seasonal concentration variation (NOM Data-base- xtract). 2.2: NOM values (see arrows), SAC and SUVA (see rectangle) for raw water (M258) and water after ozonation (M263).

Table 2.1

Partitioning of Organic Carbon (OC)								Chromatographic Fractionation of Organic Carbon (CDOC)															
TOC	DOC	UV		POC	HOC	CDOC	Poly-saccharidic	DON		Humic Subst. (HS)	DON	C/N	UV	Aromaticity	Mol-Wt.	300-500	350	350	350				
		SAC	SAC/OC					(Norg)	ppb-C/ppb-N							Blocks	LMW	LMW	Neutrals				
total ppb-C	dissolved ppb-C	(m ⁻¹)	L/(mg ^o m)	particul. ppb-C	hydrophob. ppb-C	hydrophil. ppb-C	ppb-C	(Norg) ppb-N	ppb-C/ppb-N	ppb-C	(Norg) ppb-N	ppb-C/ppb-N	(m ⁻¹)	L/(mg ^o m)	(Mn) g/mol	ppb-C	ppb-C	ppb-C	ppb-C				
M258 - 24.10.2006	1231	1175	3.0	2.4	55	127	1048	55	6.2	9	641	39	17	2.1	2.90	767	164	70	0	119			
M258 - 03.01.2007	1095	1067	3.0	2.7	29	96	971	38	5.3	7	591	29	20	2.0	3.09	630	167	57	0	118			
M258 - 06.05.2008	1367	1323	3.2	2.3	44	160	1164	58	4.7	12	591	18	34	2.0	3.09	743	251	42	0	222			
M258 - 08.07.2008	1201	1181	3.1	2.6	20	42	1138	74	12.1	n.d.	596	14	n.d.	2.1	3.27	889	214	35	0	219			

Table 2.2

Partitioning of Organic Carbon (OC)								Chromatographic Fractionation of Organic Carbon (CDOC)															
TOC	DOC	UV		POC	HOC	CDOC	Poly-saccharidic	DON		Humic Subst. (HS)	DON	C/N	UV	Aromaticity	Mol-Wt.	300-500	350	350	350				
		SAC	SAC/OC					(Norg)	ppb-C/ppb-N							Blocks	LMW	LMW	Neutrals				
total ppb-C	dissolved ppb-C	(m ⁻¹)	L/(mg ^o m)	particul. ppb-C	hydrophob. ppb-C	hydrophil. ppb-C	ppb-C	(Norg) ppb-N	ppb-C/ppb-N	ppb-C	(Norg) ppb-N	ppb-C/ppb-N	(m ⁻¹)	L/(mg ^o m)	(Mn) g/mol	ppb-C	ppb-C	ppb-C	ppb-C				
M258 - 08.07.2008	1201	1181	3.1	2.6	20	42	1138	74	12.1	n.d.	596	14	n.d.	2.1	3.27	889	214	35	0	219			
M263 - 08.07.2008	1166	1155	1.9	1.6	11	117	1039	60	10.8	n.d.	533	13	n.d.	1.1	1.92	950	243	36	0	165			

pending on their molecular weight distribution. Furthermore, laboratory tests were carried out with more dense membranes, nanofiltration (NF) and reverse osmosis (RO), (Meylan et al., 2007). The results show that LMW organics can be retained by NF-, or RO-membranes to a very high percentage (>90%) if their cut-off is very small (200–400D). AOC-analysis showed that the part of LMW-organics and -neutrals (3–5%) which permeates through these membranes contains more than 60% of the AOC. It can be concluded that, even when a high retention of NOM is observed during NF-filtration, it does not result in biologically more stable water since the permeate still contains the major part of the AOC.

REFERENCES

Huber, S.A., Frimmel F.H. (1992a) A New Method for the Characterization of Organic-Carbon in Aquatic Systems, *International Journal of Environmental Analytical Chemistry*, 49, 49–57.

Huber, S.A., Frimmel F.H. (1992b). A liquid chromatographic system with multi-detection for the direct analysis of hydrophilic organic compounds in natural waters. *Fresenius J. Anal. Chem.* 342 (1–2), 198–200

Velten, S., Hammes, F., Boller, M., Egli, T. (2007) Rapid and direct estimation of active biomass on granular activated carbon through adenosine tri-phosphate (ATP) determination. *Water Research*, 41(9): 1973–1983.

WAVE21 PUBLICATIONS RELEVANT FOR THIS WORK PACKAGE

Boller M., Velten S., Peter A., Hammes F., Helbing J. (2008) Trinkwasseraufbereitung mit Aktivkohle. *Neue Erkenntnisse*. GWA 1, 1–9.

Hammes, F., Meylan, S., Salhi, E., Köster, O., Egli, T., von Gunten, U. (2007) Formation of assimilable organic carbon (AOC) and specific natural organic matter (NOM) fractions during ozonation of phytoplankton. *Water Research* 41, 1447–1454.

Hammes, F., Salhi, E., Köster, O., Kaiser, H.P., Egli, T., von Gunten, U. (2006) Mechanistic and kinetic evaluation of organic disinfection by-product and assimilable organic carbon (AOC) formation during the ozonation of drinking water. *Water Research* 40, 2275–2286.

Jermann D. (2008) Membrane fouling during ultrafiltration for drinking water production: causes, mechanisms and consequences. Diss., ETH Zurich, Nr. 17811

Jermann, D., Pronk, W., Meylan, S., Boller, M. (2007) Interplay of different NOM fouling mechanism during ultrafiltration for drinking water production, *Water Research*, 41, 1713–1722

Meylan S., Hammes, F., Traber, J., Salhi, E., von Gunten, U., Pronk, W. (2007) Permeability of low molecular weight organics through nanofiltration membranes *Water Research*, 41, 3968–3976

Ramseier M. K., von Gunten U. (2009) Mechanisms of phenol ozonation – kinetics of formation of primary and secondary reaction products. *Ozone Sci. Eng.*, 31, 201–215.

Velten S. (2008) Adsorption Capacity and Biological Activity of Biological Activated Carbon Filters in Drinking Water Treatment. Diss., ETH Zurich, Nr. 18037.

Velten S., Knappe D., Traber J., Kaiser H.-P., von Gunten U., Boller M., Meylan S. Characterization of natural organic matter adsorption in granular activated carbon adsorbents, submitted to *Water Research*.

1.3 PARTICLES

INTRODUCTION

In aquatic sciences, particulate and dissolved matter is operationally defined by filtration through $0.45\mu\text{m}$ filters. The idea behind this is that substances $<0.45\mu\text{m}$ remain in suspension while larger particles sediment due to the gravitational force. Artifacts related to filtration procedures have been extensively discussed in literature and are mainly based on the reduced pore size due to filter clogging. In addition, a significant amount of particulate material can pass through the $0.45\mu\text{m}$ filter and will be treated as 'dissolved' species. A colloidal fraction has thus been introduced to account for the particles that can pass the filtration procedure but cannot be treated as dissolved species. The colloids span the size range between 1 and 1000nm , do not have a significant settling rate, and cannot be removed by sedimentation (Fig. 15).

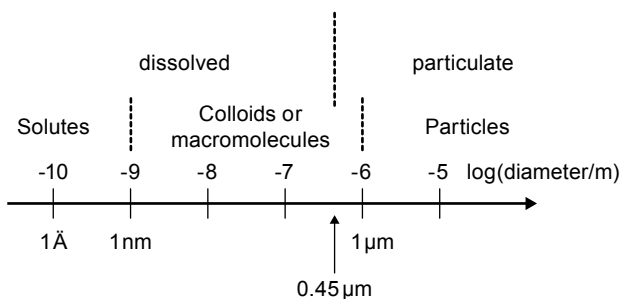

Fig. 15: Definition of different size fractions.

To characterize particles within the Wave21 project, the following methods were applied:

AFM (Atomic Force Microscopy): In this technique a fine tip is scanned over the surface of the sample. It provides morphological information about the sample with a superb resolution (sub nanometer) in the vertical direction (height of the sample). This technique can be applied under ambient condition thus reducing artefacts related to sample preparation and/or high vacuum condition.

TEM (Transmission Electron Microscopy): In this technique the sample is irradiated with parallel light (electrons) and the image of the transmitted electrons are visualized by either a fluorescent screen or recorded on a CCD camera. The technique provides 2D projection of the particles on the sample carrier. In addition, elemental analysis of individual particles can be performed by focusing the electron beam on a particle and analysing the X-ray produced by the interaction of the electron beam with the sample material (EDX, energy dispersive analysis). The TEM analyses are very powerful, as they provide both, morphological (2D) and chemical information about individual particles. However, the technique requires high-vacuum conditions, which introduces artefacts especially when investigating hydrated material.

STXM (Scanning Transmission X-ray Microscope): These analyses have to be performed at a synchrotron facility (we

used the SLS (Swiss Light Source), Paul Scherrer Institute, Villingen, Switzerland). An X-ray beam of a defined wavelength (energy) is 'scanned' (in practice, the beam is fixed and the sample moved with piezo-motors relative to the X-ray beam) over the sample and transmitted energy is recorded. Carbon based material can be well characterized using this technique, as different functional groups (such as carbonyl, carboxyl and phenol) can be detected.

LIBD (Laser Induced Breakdown Detection): This new laser based method provides information about the colloidal size (20–500 nm) and concentration in aqueous samples. The method is largely non-intrusive and requires the least sample preparation (only dilution is needed, if the concentration is too high). These analyses were performed at the Forschungszentrum Karlsruhe.

OBJECTIVES

The size limit of most of the currently available measurement systems is around $0.5\text{--}1\mu\text{m}$ and they are not capable of detecting colloids in surface or drinking waters. Our investigations therefore aimed at detecting and characterizing the colloids in the drinking water after different treatment trains. Due to the well known artefacts related to filtration procedures (filter clogging), we used an alternative approach to size fractionate the particles and colloids. Our procedure consisted of initial sedimentation in combination with subsequent, stepwise centrifugation (based on the approach published by Perret et al., 1994).

RESULTS AND DISCUSSION

Within the Wave21 project, two different approaches for the particle characterization were pursued: i) detailed investigation of individual particles using microscopic methods and ii) fast on-line characterization of the particles. The first approach is designed to deliver high-quality information about the particles

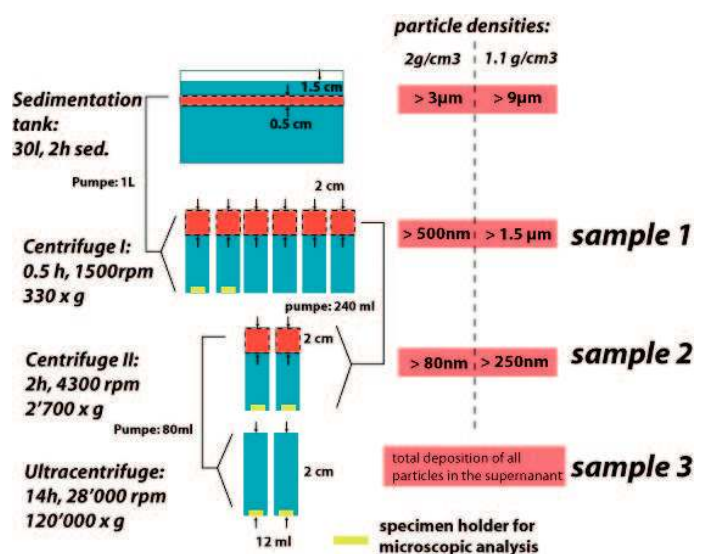

Fig. 16: Procedure to size fractionate the particles/colloids. The particle densities refer to the maximum diameter of a particle (with the given density) that will be removed by the respective fractionation step.

but is very laborious and requires a rough size fractionation of the particles prior to the analysis. The procedure for the particle separation is briefly outlined in Fig. 16. The second approach is designed to deliver rapid (time resolution of a few minutes) but more qualitative information about the number and the average size of the particles down to a few tens of nm without any sample pre-treatment. As no commercially available instruments fulfil these demands, the construction of a new instrument – Laser Induced Breakdown Detection – was initiated (based on a prototype developed by the Forschungszentrum Karlsruhe).

The samples obtained by the procedure outlined above were analyzed with various microscopic techniques. The focus thereby was set on the smallest size fraction containing colloids up to 100–200 nm in diameter (sample 3 in Fig. 16).

During the Wave21 project we investigated the colloids remaining in the water after conventional full-scale treatment of Lake Zurich water and after the pilot-plant treatment which includes ultrafiltration. Both treatment trains are highly efficient in the removal of particles ($> 1 \mu\text{m}$) which was also confirmed by online particles counters installed at the water works. Therefore, we focused our research on the colloids ($< \sim 200 \text{ nm}$, last ultra-centrifugation step). Significant differences were observed between the two treatment trains which are briefly summarized below.

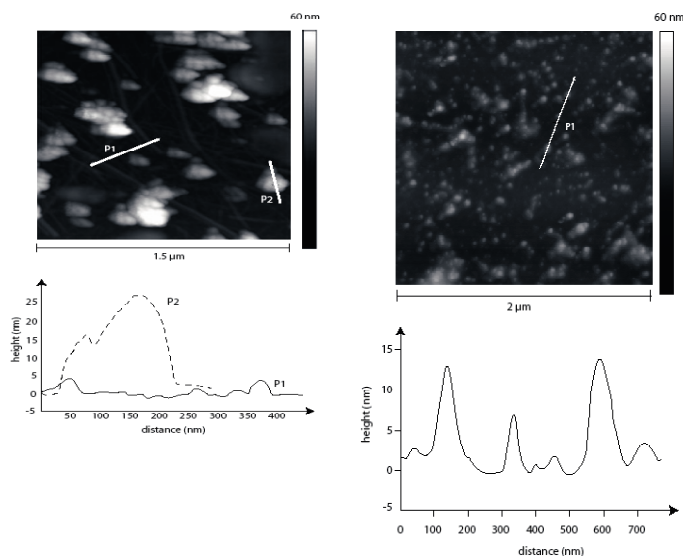

Fig. 17. AFM images of colloids from water samples after the conventional (left) and after the membrane treatment train (right).

The AFM analysis performed on the samples after the conventional treatment train (Fig. 17, left) revealed two distinct particle types, spherical entities (mostly consisting of agglomerated spherical colloids) and fibrous particles (up to a few 100 nm in length). In the sample after the membrane treatment train, (Fig. 17, right), only spherical particles were found, which were considerably smaller than the spherical aggregates observed in the sample after the conventional treatment train. Similar observations were also made with the TEM. Based on literature stud-

ies, the spherical colloids are interpreted as aggregates of humic substances, and the fibrous particles as polysaccharides. These results indicate that the polysaccharides are retained by the membrane filtration but can penetrate through the conventional treatment train. In addition, the smaller diameter of the aggregates of the humic substances can be explained by the smaller cut-off of the membrane treatment train compared to the classical treatment.

The LIBD analysis performed off-line at the Forschungszentrum in Karlsruhe showed that the average diameter of the colloids were smaller after the pilot plant, which includes an ultrafiltration compared to the average size of the colloids after the conventional treatment train. In addition, the concentration of the colloids (membrane: $1 \times 10^8 \text{ \#/mL}$, conventional: $7 \times 10^8 \text{ \#/mL}$) was lower by roughly one log unit in the sample after the membrane in the pilot plant. Also, these findings are consistent with the interpretation of a smaller size cut-off of the membrane filtration compared to the conventional treatment train. STXM analyses were only performed on the sample from the conventional treatment train and the measured spectra were similar to published spectra obtained from dissolved organic matter (Schumacher et al., 2005).

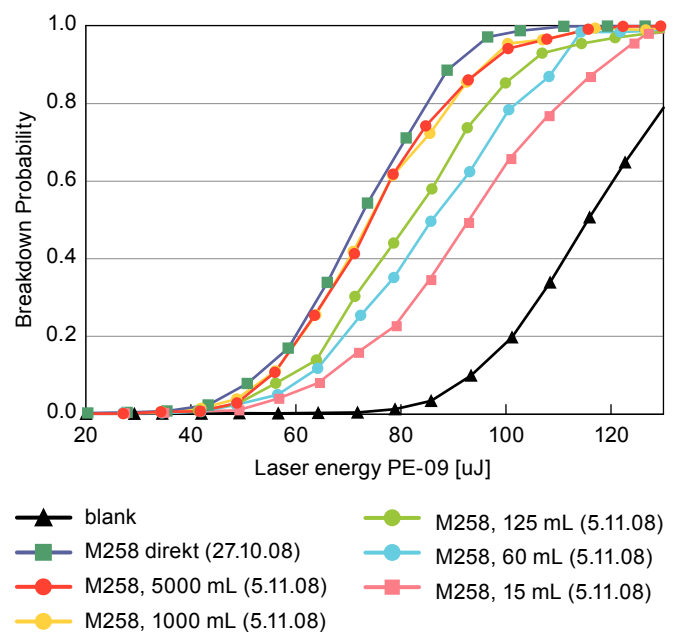

Fig. 18. Energy curves recorded on our LIBD system. Samples from the M258 sampling point were stored in containers having different volumes.

Based on the preliminary results we obtained from the LIBD measurements, we have developed a portable LIBD system at Eawag in collaboration with ETHZ (Prof. D. Günther). A flow cell enabling continuous measurements on-site has recently been integrated. First results – although only qualitatively – clearly demonstrate the effect of sample storage on the particle population (Fig. 18).

Qualitatively, the slope of the curves can be taken as a proxy for the number concentration of the particles and the initial rise of the curve can be taken as a proxy for the average size of the particles. Thus, this graph nicely shows that the number concentration drops as a function of the size of the sample container, which can be explained by the adsorption of particles to the wall of the sample container. The size of the particles remains rather constant indicating that the loss of the particles is not caused by the coagulation.

CONCLUSIONS

Significant differences were observed in the colloidal size range between the conventional treatment process and the pilot-scale treatment train including ultrafiltration. The use of the LIBD technique is very promising as it provides a very fast screening of the colloidal content of the samples. The high sensitivity of the LIBD system combined with 'on-line' capabilities would then enable monitoring the colloidal content of the drinking water. Further investigations along these lines are currently carried out.

REFERENCES

- Perret D., Newman M.E., Negre J. C., Chen Y.W., Buffle J. (1994) Submicron Particles in the Rhine River .1. Physicochemical Characterization. *Water Research*, 28, 91–106.
- Schumacher M., Christl I., Scheinost A.C., Jacobsen C., Kretzschmar R. (2005) Chemical heterogeneity of organic soil colloids investigated by scanning transmission X-ray microscopy and C-1s NEXAFS microspectroscopy. *Environmental Science & Technology*, 39, 9094–9100.

WAVE21 PUBLICATIONS RELEVANT FOR THIS WORK PACKAGE

- Kaegi, R., Wagner, T., Hetzer, B., Sinnet, B., Tzuetkov, G. & Boller, M. (2008) Size, number and chemical composition of nanosized particles in drinking water determined by analytical microscopy and LIBD, *Water Research*, 42, 2778–2786.

1.4 TASTE AND ODOR COMPOUNDS

INTRODUCTION

Taste and odor (T&O) control is an important issue for drinking water suppliers because consumers react very sensitively to changes in the organoleptic quality of their drinking water. T&O compounds in drinking water are derived from algal or microbial metabolism. Despite intensive research in this field, it is difficult and time-intensive to assess the involved T&O compounds in the case of consumer complaints. This can be explained by the individual perception of T&O in drinking water and the very low odor thresholds of many T&O compounds (typically in the low ppt-range). While worldwide many water utilities are confronted with sometimes massive T&O problems, widespread T&O problems have been avoided in Switzerland by water resources protection and the application of a multi-barrier drinking water treatment. However, if parts of the current treatment trains are to be replaced by new treatment techniques in future, e. g., membrane filtration, it has to be guaranteed that T&O problems do not evolve. Therefore, detailed knowledge of the natural occurrence of T&O compounds as well as their behavior during drinking water treatment and possible forming during distribution is needed.

OBJECTIVES

Work package 1.4 aimed to assess the natural occurrence and seasonal fluctuations of T&O compounds in surface waters. Towards this end, an analytical approach, namely the combination of an instrumental and organoleptic method (ODP), that is widely applied in the food and flavor industry, has been further developed to detect and quantify T&O compounds in the low ppt-range in natural and drinking waters. Using this combined approach (Fig. 19), the T&O situation in three Swiss lakes (Lake Greifensee, Lake Zurich and Lake Lucerne) was investigated. Furthermore, the method was applied to detect T&O compounds that were generated in a distribution system.



Fig. 19. Sensory detection of T&O compounds at the Sniff-Port; organoleptic detection port (ODP)

Another important topic of work package 1.4 was the investigation of the behavior of selected T&O compounds during drinking water treatment. The main focus was on ozone-based oxidation processes, which have proved to be very appropriate for T&O control in numerous studies. Bench-scale experiments were performed to determine second order rate constants for the reaction of eleven relevant T&O compounds with ozone and hydroxyl radicals ($\bullet\text{OH}$), which are powerful oxidants that are formed during the decomposition of aqueous ozone. These kinetic data provide a useful tool to estimate and consequently, optimize the removal of T&O compounds during ozonation. Additionally, ozonation experiments with natural water were performed on laboratory- and pilot-scale to evaluate the applicability of ozonation for T&O control in real reactor systems. These results are presented together with a more general overview of micropollutant oxidation and the formation of undesired oxidation by-products in work package 2.1.

RESULTS AND DISCUSSION

Analytical method for T&O analysis in drinking and natural water

The developed analytical method, which combined olfactory with GC-MS detection after extraction with headspace-SPME (solid phase micro extraction), proved to be highly sensitive and selective for the analysis of T&O compounds in natural and drinking water. The detection limits for the investigated compounds were in the sub ppt to low ppt range.

Fig. 20 illustrates the combined chromatogram for one of the lake samples analyzed in this study. Without the information from the ODP, a reliable detection of two of the identified T&O compounds (MIB and β -ionone) would not have been possible because their MS peaks were overlapped by neighboring peaks.

T&O compounds in surface waters

In the course of this study, six T&O compounds could be identified in the three investigated lakes (Table 3). As reported in previous studies, the identified compounds showed a general correlation to phytoplankton and therefore, higher abundance in eutrophic water bodies (Lake Greifensee > Lake Zurich > Lake Lucerne). But even in eutrophic Lake Greifensee, the peak concentrations of the identified T&O compounds amounted only to a few ng L^{-1} , while in literature studies surface waters with several 100 ng L^{-1} of certain T&O compounds are described.

A substantial part of the identified T&O compounds was not dissolved in the lake water, but particle-bound in the phytoplankton cells (Table 3). This intracellular fraction was particularly pronounced for β -ionone in Lake Zurich. Our data revealed that the occurrence of β -ionone was largely influenced by the cyanobacterium *Planktothrix rubescens*. This is the first time that a correlation between β -ionone and this species in natural waters has been reported. This is a relevant information for water utilities which treat surface water because *Planktothrix rubescens* can be abundant in surface waters during fall and winter. When this water is treated without a preceding removal of

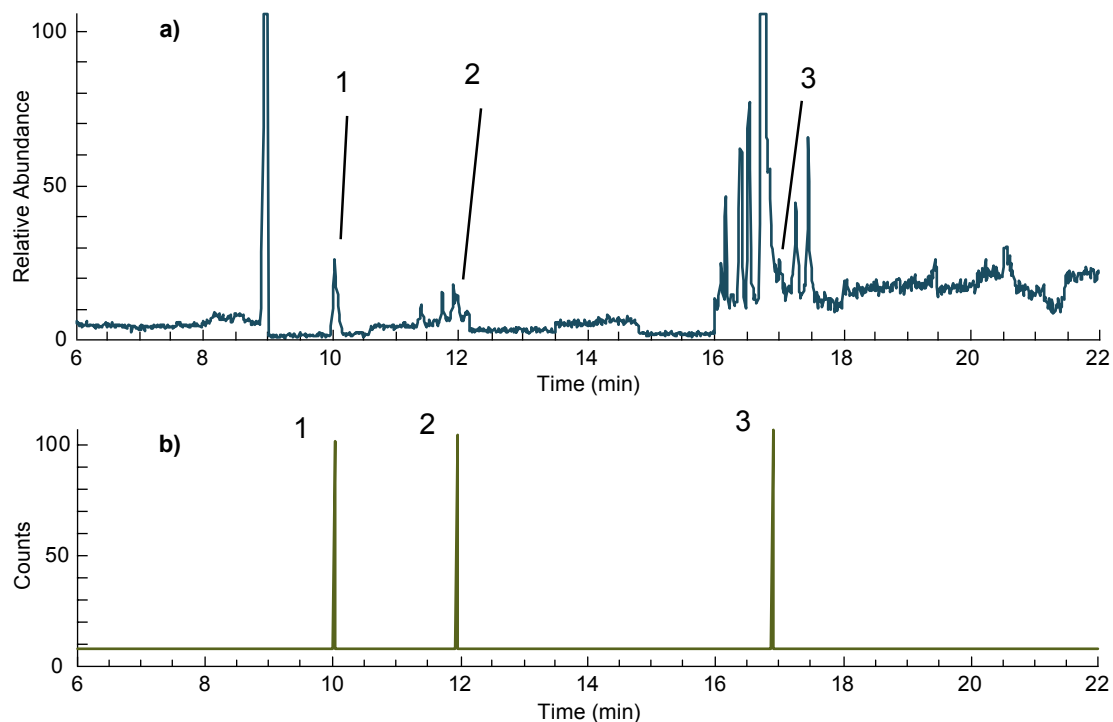

Fig. 20. Chromatogram of a sample analyzed with SPME-GC-MS/ODP (Lake Zurich, June 2006). a) MS-chromatogram, b) ODP-signal (“sniff-port”). Detected compounds (in brackets: the detected odor at the ODP): 1) 2-isopropyl-3-methoxypyrazine (decaying), 2) 2-methylisoborneol (musty), 3) β -ionone (violets).

TABLE 3. T&O Compounds identified in three Swiss lakes with peak concentrations (ng L^{-1})^a

Compound (odor threshold)	structure	Lake Lucerne	Lake Zurich	Lake Greifensee	peak season
geosmin (4 ng L^{-1})		1.5 ± 0.6 (d)	5.7 ± 0.6 (d)	19.0 ± 0.7 (d)	summer
β -ionone (7 ng L^{-1})		0.3 ± 0.1 (p)	27.5 ± 1.8 (p)	1.6 ± 0.1 (p)	summer / fall
2-isobutyl-3-methoxypyrazine (IBMP) (1 ng L^{-1})		< 2 (p)	< 2 (p)	< 2 (p)	no seasonal trends
2-isopropyl-3-methoxypyrazine (IPMP) (0.2 ng L^{-1})		10.0 ± 0.3 (p)	14.7 ± 0.5 (p)	16.1 ± 0.5 (p)	summer
2-methylisoborneol (MIB) (15 ng L^{-1})		1.3 ± 0.1 (p)	2.6 ± 0.1 (p)	2.7 ± 0.1 (p)	summer

^a Errors = 95% confidence intervals, calculated from the calibration with six external standards
in brackets: d = dissolved; p = particulate fraction

particles, particle-bound compounds such as β -ionone might be released during drinking water treatment and eventually get into the tap water. However, the low T&O concentrations in the investigated lakes and the multi-barrier approach that is chosen for surface water treatment in Switzerland, make it unlikely that T&O problems could be generated in the investigated areas from algal T&O compounds. Nevertheless, future changes (climate, nutrients) might affect the phytoplankton community and accentuate the production of T&O compounds.

Oxidation of T&O compounds

The determined second order rate constants for the reaction of selected T&O compounds with ozone and hydroxyl radicals are summarized in Table 4. These data underline the selectivity of ozone, but also the high reactivity of hydroxyl radicals toward organic compounds. Therefore, an oxidation of >50% can be expected even for compounds with low reactivity towards ozone during typical drinking water treatment conditions. The corresponding results from pilot-scale studies in natural water are presented in work package 2.1.

TABLE 4. Second order rate constants for the reaction of ozone and \cdot OH with selected T&O compounds

Compound	k_{O_3} ($M^{-1}s^{-1}$)	$k_{\cdot OH}$ ($10^9 M^{-1}s^{-1}$)
β -cyclocitral	3890	7.4
geosmin	0.1	7.8
3-hexen-1-ol	5.4×10^{-5}	7.5
β -ionone	1.6×10^{-5}	7.8
2-isopropyl-3-methoxypyrazine	50	4.9
2-methylisoborneol	0.4	5.1
2,6-nonadienal	8.7×10^5	9.7
1-penten-3-one	5.9×10^4	4.7
BHT	7.4×10^4	3.2
2,4,6-tribromoanisole	<0.1	3.7
2,4,6-trichloroanisole	<0.1	5.1

T&O compounds in the distribution system

In a case study, the application of the presented method for T&O analysis allowed to identify the potent T&O compound 2,4,6-trichloroanisole (TCA) in the tap water of a Swiss town that was confronted with consumer complaints. Fig. 21 shows the supposed formation mechanism of TCA. It is assumed that phenolic/aromatic precursors were chlorinated to 2,4,6-trichlorophenol (TCP), which was eventually transformed to TCA by microorganisms.

Experiments conducted in the laboratory with a biofilm-covered particle filter, which was dismantled from one of the homes where the residents had T&O problems, confirmed the role of biofilms and the precursors (aromatic compounds and chlorine addition) in TCA formation. Fig. 22 shows the result-

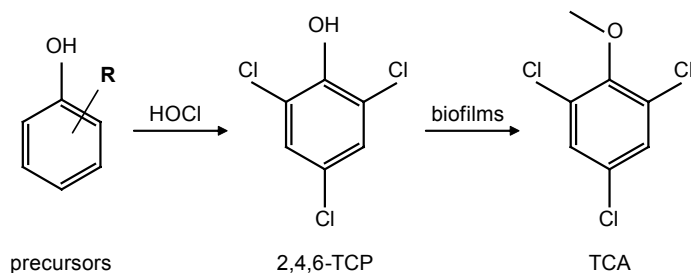

Fig. 21. Simplified formation mechanism of TCA in the distribution system. HOCl: hypochlorite (residual disinfectant); TCP: trichlorophenol.

ing TCA concentrations of these experiments. No TCA formation could be observed with unspiked water from the distribution system. The outcome of the experiment with TCP addition illustrates the transformation of TCP into TCA. The experiment with chlorine addition, which also led to TCA formation, indirectly confirms the formation of TCP after the addition of the residual disinfectant. The resulting TCA concentrations were similar as detected in the tap water in this home (24 ng L^{-1}). Based on these results, appropriate counter-measures, such as water distribution without a residual disinfectant, could be taken to mitigate the T&O problem.

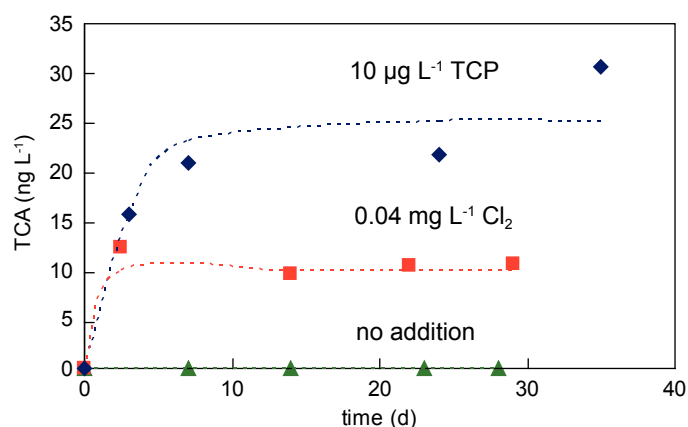

Fig. 22. TCA formation in a particle filter after spiking of the water with precursors (room temperature).

CONCLUSIONS

Worldwide, most of the reported T&O problems, apart from disinfectant residuals in the tap water, can be traced back to algal metabolites and could be mitigated by an optimized drinking water treatment and appropriate measures at source level, e.g., limitation of algal growth through a reduction of the nutrient load into surface waters. In contrast, T&O problems in Switzerland are probably mainly generated in the distribution system. These problems can be addressed by an optimal choice of the components that are in contact with the water and optimal design of the distribution system that prevents long water residence times.

Concluding, it is important to note that it is not possible to give general recommendations about the mitigation of T&O problems because specific solutions have to be found for each case. work package 1.4 can serve as a basis for solution of T&O problems by providing:

- An analytical method for a reliable detection and quantification of T&O compounds.
- Improved knowledge of the treatment of surface water derived T&O compounds.
- Mitigation strategies of T&O problems in distribution systems.

WAVE21 PUBLICATIONS RELEVANT FOR THIS WORK PACKAGE

- Peter A. and von Gunten U. (2007) Oxidation kinetics of selected taste and odor compounds during ozonation of drinking water, *Environ. Sci. Technol.*, 41, 626–631.
- Peter A., Koester O., Schidknecht A., von Gunten U. (2009) Occurrence of Dissolved and Particle-bound Taste and Odor Compounds in Swiss Lake Waters, *Water Res.*, 43, 8, 2191–2200.
- Peter A. and von Gunten U. (2009) Taste and Odor Problems Generated in Distribution Systems - A Case Study about the Formation of 2,4,6-trichloroanisole, *Journal of Water Supply, Research and Technology – Aqua*, 58,6, 386–394.
- Peter A. (2008) Taste and odor in drinking water: Sources and mitigation strategies. Diss. ETH, Nr. 17661.
- Velten, S., Strübing, D., Peter, A., Boller, M., Removal of 2-Isopropyl-3-methoxypyrazine (IPMP) with granular activated carbon: from lab scale to pilot scale, Chapter 5 in Dissertation S. Velten.

1.5 MICROPOLLUTANTS

INTRODUCTION

A schematic representation of the anthropogenic water cycles is shown in Fig. 23. The system is based on multi-barriers and originally aimed at the removal of pathogenic microorganisms but has been adapted to cope with the removal of micropollutants. Drinking water used in households is transformed into wastewater which is discharged (via a sewage treatment plant or directly) into the water resources or directly reused for drinking water. If discharged into the environment, natural attenuation processes in the environment (filtration, adsorption, chemical and biological transformation) and dilution lead to a significant reduction of the concentrations of micropollutants before this water is used (treated or non-treated) for drinking water again. Through wastewater, numerous micropollutants such as pharmaceuticals and hormones are discharged into the receiving waters. Water resources are also affected by other anthropogenic activities (agriculture, traffic, industry, landfills) that lead to their contamination by pesticides, fuel (additives), solvents, and other synthetic organic chemicals. In addition, natural processes may lead to the release of various toxic (arsenic, fluoride, manganese) and non-toxic, but undesired (e.g., iron) elements. The production of algal toxins (cyanotoxins) and taste and odor compounds is often related to the discharge of nutrients by wastewater and agriculture into the water bodies.

An additional class of micropollutants may be even formed during drinking water treatment itself. The application of chemical oxidants such as chlorine and ozone may lead to the formation of oxidation by-products such as trihalomethanes, bromate, NDMA, etc., from the reaction of these oxidants with water matrix components.

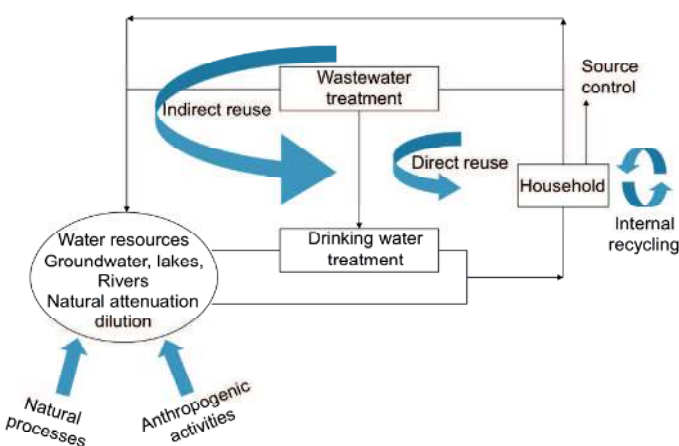

Fig. 23. Schematic representation of the anthropogenic water cycle with the possible sources and attenuation of micropollutants.

Even though the majority of the micropollutants are synthetic organic compounds from the wealth of 100'000 synthetic chemicals which are registered e.g. in the EU, some natural inorganic and organic compounds may play an equally important role

worldwide. In addition, the formation of oxidation by-products during disinfection has to be considered and the corresponding processes have to be optimized.

Depending on the point of entry of micropollutants in the anthropogenic water cycle, treatment can be placed in a varying location. For the removal of micropollutants several treatment options are possible, namely physical separation, adsorption, oxidation and biological transformation. The big challenge is the water matrix (mainly bulk organic matter), which is typically present in 1'000–1'000'000 times higher concentrations than the micropollutants and lowers the efficiency of the processes significantly. Therefore, the selectivity of a process is crucial for the economic feasibility of a treatment step.

Pharmaceuticals and hormones enter the wastewater mostly through urine and could be removed directly at the source (source control). This has the advantage that they can be removed while they are still in fairly high concentrations (up to mg/L level). However, the urine matrix is very complex and highly concentrated which seriously challenges all available treatment technologies (membranes, oxidation and adsorption processes). During wastewater treatment some of these compounds are removed in activated sludge processes by adsorption and biodegradation. However, many compounds are not or only partially removed and are discharged into the environment where they can be further attenuated or persist in the water resources. To avoid their discharge, enhanced wastewater treatment such as ozonation or powdered activated carbon are currently discussed to be applied in areas with low dilution ratios. The increasing water demand will make it necessary to recycle the water in shorter cycles (direct water reuse), which is possible through the use of various pre-treatment steps followed by reversed osmosis (RO). The challenge of this technology is the high fraction of rejected concentrate (30–50%) which has to be discharged. In areas close to the sea it can be discharged into the ocean, whereas inland it is difficult to handle these concentrates. Persistent toxic micropollutants, which get into the water resources through the various diffusive pathways can only be removed during drinking water treatment. Several unit processes (nanofiltration, adsorption to activated carbon, ozonation and advanced oxidation processes) have been optimized to achieve this goal.

Treatability of micropollutants

Water treatment for the removal of micropollutants is challenged by the overwhelming concentration of the matrix (mainly bulk organic matter) and the structural variety of the compounds of concern. Matrix problems can generally only be overcome partially by multiple treatment steps, by first reducing the concentration of background organic matter, before the removal of micropollutants can be tackled. That way, the undesired effects of the organic matrix, namely fouling of membranes, consumption of oxidants and oxidation by-product formation and blocking of adsorption sites can be minimized. Novel treatment options and schemes should therefore include highly selective treatment processes. It has for example been shown that estrogenic compounds in the mg/L range can be oxidized by ozone in a

wastewater matrix (DOC 7 mg/L) with low ozone doses 2 mg/L because ozone reacts with high rates with these compounds (Huber et al., 2005).

OBJECTIVES

One of the main concerns for drinking water quality is the ever increasing number of micropollutants detected in the water resources. It is impossible to monitor all of them across water treatment. In addition, often the human toxicological relevance of micropollutants is unknown.

Therefore, tools have to be developed to assess the removal efficiency by the various treatment processes based on the characteristics of the treatment step (filtration, adsorption, oxidation) and the physical-chemical properties (solubility, reaction rates, size, charge, etc.) of the micropollutants. First steps in this direction have been made for oxidation and adsorption processes within this project.

The objective of work package 2.5 was to test the removal efficiency for organic micropollutants during long-term operation of the Lake Zurich pilot plant. Two aspects were covered, namely the removal of micropollutants during standard operation and for shock loading caused by accidental spills. The two main processes investigated were activated carbon adsorption (work package 2.3) and ozonation (work package 2.1). Furthermore, the formation of oxidation by-products was tested in the laboratory- and pilot-scale treatment (bromate, AOC).

RESULTS AND DISCUSSION

The results for micropollutant elimination in the pilot plant are reported in more detail in work package 2.1 for ozonation, and work package 2.3 for activated carbon filtration. The main results for micropollutant elimination in the pilot plant are summarized in Fig. 24.

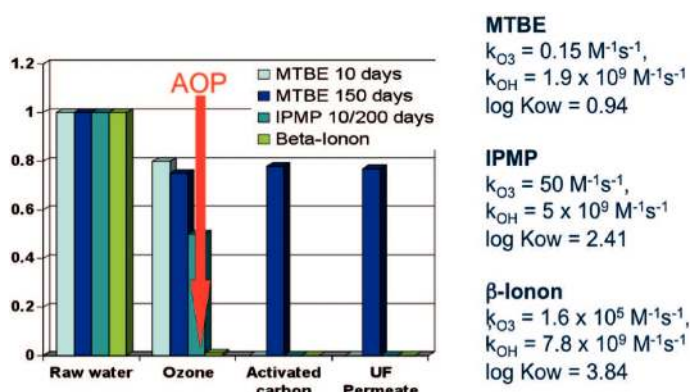

Fig. 24. Elimination of the three representative micropollutants MTBE, IPMP and β -Ionone in the Lake Zurich pilot plant comprising of ozonation, activated carbon filtration and ultrafiltration.

The three compounds shown in Fig. 24 are representative for properties of many other organic micropollutants. MTBE, a fuel additive, is a highly polar and well water-soluble compound and has no reactivity with ozone and a relatively low reactivity with OH radicals. IPMP, a taste and odor compound, is much less polar (high log Kow) and water-soluble, has an intermediate reactivity with ozone and reacts fast with OH radicals. β -Ionone, also a taste and odor compound, is even less polar (high log Kow) and has a high reactivity with ozone and OH radicals. These physical chemical properties are well reflected in the degree of elimination of the selected compounds in the pilot plant (Fig. 24). MTBE is only degraded by 20% during ozonation. This is due to OH radical reactions and is independent of the time of treatment (10 days and 150 days of operation of the pilot plant show the same results). The inherent self-renewing of the oxidation processes is one advantage compared to other processes. This is reflected for the activated carbon step. MTBE is well retained after 10 days of operation of the pilot plant, whereas it is not eliminated after 150 days. At this stage, activated carbon is fully saturated with DOM and therefore the adsorption capacity for MTBE is exhausted. The aging of activated carbon due to loading with DOM is an inherent problem for this process for long-term operation. After passage through activated carbon, there is, as expected, no further retention in ultrafiltration. For IPMP, which has a higher reactivity with ozone, already a 50% removal can be observed during ozonation. The difference between MTBE and IPMP is mostly due to the higher second-order rate constant for the reaction of IPMP with OH radicals. However, also the higher reactivity of IPMP with ozone, leads to the better elimination of this compound. Due to the higher Kow of IPMP, this compound is fully eliminated in activated carbon filtration even after 200 days. β -Ionone, reacting very fast with ozone, is already fully eliminated during the ozonation step. Therefore, the most problematic micro-pollutants seem to be compounds with a low reactivity with ozone and a low Kow. However, to remove these compounds, the ozonation step can be transformed into an advanced oxidation by adding hydrogen peroxide into the ozonation reactor. This has been successfully done for a variety of taste and odor compounds and for the OH radical tracer pCBA and is described in more detail in work package 2.1. This treatment option is quite interesting in case of accidental spills, for which a fast and reliable mitigation strategy is required. Hydrogen peroxide can be stored in the water works and added in case of emergency.

One of the drawbacks of oxidation processes is that for typical treatment conditions no full mineralization of these compounds can be achieved. In numerous related studies with antimicrobial and estrogenic compounds it could be shown that the biological effects disappear already with a minor degree of transformation. This is based on the specific interaction of these molecules with target sites. In general, oxidation leads to more polar compounds, which are much less susceptible to penetration through membranes and therefore makes them less toxic. In one case

however, a metabolite of a fungicide, namely dimethylsulfamide, was found to form NDMA in high yields. Since NDMA is a known carcinogen, in this case the oxidation transforms a harmless into a harmful compound.

Overall, it could be shown, that the tested treatment train is a good option for the removal of organic micropollutants with a wide variety of physical chemical properties and that it can be “upgraded” to also cope with accidental spills.

REFERENCES

Huber, M. M., Göbel, A., Joss, A., Hermann, N., McArdeell, C. S., Ried, A., Siegrist, H., Ternes, T. A., von Gunten, U. (2005) Oxidation of pharmaceuticals during ozonation of municipal wastewater effluents: a pilot study, *Environ. Sci. Technol.*, 39, 4290–4299.

WAVE21 PUBLICATIONS RELEVANT FOR THIS WORK PACKAGE

- Boller M., Velten S., Peter A., Hammes F., Helbing J. (2008) Trinkwasseraufbereitung mit Aktivkohle. *Neue Erkenntnisse. GWA* 1, 1–9.
- Peter A. and von Gunten U. (2007) Oxidation kinetics of selected taste and odor compounds during ozonation of drinking water, *Environ. Sci. Technol.*, 41, 626–631.
- Peter A., Koester O., Schildknecht A., von Gunten U. (2009) Occurrence of Dissolved and Particle-bound Taste and Odor Compounds in Swiss Lake Waters, *Water Res.* 43, 8, 2191–2200.
- Peter A. and von Gunten U. (2009) Taste and Odor Problems Generated in Distribution Systems – A Case Study about the Formation of 2,4, 6-trichloroanisole, submitted to *Journal of Water Supply, Research and Technology – Aqua* 58, 6, 386–394.
- Peter A. (2008) Taste and odor in drinking water: Sources and mitigation strategies. *Diss. ETH*, Nr. 17661.
- Velten, S., Boller, M., Kaiser, H.-P., Knappe, D.R.U., Effects of natural organic matter preloading on physical characteristics and remaining MTBE adsorption capacity of granular activated carbon, *Proc. 4th IWA Young Professionals Conference*, Berkeley, CA, USA, July 2008
- Velten, S., Strübing, D., Peter, A., Boller, M., Removal of 2-Isopropyl-3-methoxypyrazine (IPMP) with granular activated carbon: from lab scale to pilot scale, Chapter 5 in *Dissertation S. Velten*.
- Velten, S., Meylan, S., Boller, M. and Knappe, D.R.U. Surface area measurements provide an insufficient estimate for MTBE adsorption capacity of granular activated carbon., in preparation.

2 TECHNOLOGICAL TOOLBOX

2.1 OXIDATION PROCESSES

INTRODUCTION

Disinfection and oxidation processes have been applied in drinking water treatment for the last hundred years. Whereas disinfection was the primary application of oxidants such as chlorine and ozone, other oxidants have been applied for disinfection and oxidation purposes. According to a recent survey in Switzerland, the main task of oxidation is control of taste and odor issues, microflocculation and color removal (von Gunten and Salhi, 2000). In addition to these primary tasks, oxidation is also widely applied for micropollutant transformation. This has been investigated for cyanotoxins (Onstad et al., 2007, Rodriguez et al., 2007), estrogenic compounds (Huber et al., 2004), antimicrobial compounds (Dodd et al., 2006, Dodd and Huang, 2004), pharmaceuticals (Huber et al., 2003) fuel additives (Acero et al., 2001) and pesticides (Acero et al., 2000) with various oxidants such as chlorine, bromine, chlorine dioxide, ferrate, OH radicals and ozone in the context of various projects related to Wave21. In addition to kinetic and mechanistic studies, the transformation of selected classes of micropollutants has also been investigated with regard to changes in the biological activity of the partially oxidized parent compounds (Huber et al., 2004, Suarez et al., 2007). In the context of Wave21, the activities focused on ozone and ozone-based advanced oxidation processes, because of the planned integration of these processes into a future treatment scheme of lake water treatment.

Ozone is a very selective oxidant that mainly reacts with activated aromatic systems, non-protonated amines, double bonds and reduced sulfur moieties. There is a huge kinetic data base for ozone reactions with inorganic and organic compounds (>500 second order rate constants, von Gunten 2003). Based on kinetics, ozone is feasible for the removal of a wide variety of synthetic and natural organic micropollutants such as taste and odor compounds, cyanotoxins (peptide structures), estrogens (phenolic entities), antibiotics (reduced sulfur, amines) and pharmaceuticals (amines, ethenes, double bonds). An additional feature of ozone is the formation of OH radicals which can be used to oxidize micropollutants. OH radicals react less specifically than ozone, nearly diffusion-controlled with most organic compounds. Second order rate constants for the reaction of >2000 micropollutants with OH radicals are known (Buxton et al., 1988). Even though second order rate constants for the reaction of OH radicals with micropollutants are typically several orders of magnitude higher than the corresponding rate constants with ozone, the efficiency of the elimination of micropollutants reacting fast with ozone is typically much higher. This results from the fact that the degree of transformation depends on both, the second order rate constant (k) and the oxidant exposure ($\int[\text{ox}]dt$), according to eq. 1:

$$\ln ([c]/[c]_0) = k \int[\text{ox}]dt \quad (1)$$

Because of the short lifetime of OH radicals in the order of μs , the oxidant exposure for these oxidants is typically very small. OH radical based processes are generally referred to as advanced oxidation processes (AOPs). In drinking water treatment practice the following AOPs are applied: $\text{O}_3/\text{H}_2\text{O}_2$, O_3/UV , $\text{H}_2\text{O}_2/\text{UV}$. The latter process is increasingly applied because of the increased use of UV-based processes for disinfection purposes.

Besides the benefits of ozonation and AOPs (oxidation of micropollutants), there are a few restrictions to their applications: (i) OH radicals are non-selective oxidants, (ii) in many cases only a partial oxidation of micropollutants is possible, (iii) bromate formation during ozonation and in ozone-based AOPs, (iv) formation of other toxic oxidation by-products such as NDMA and (v) formation of assimilable organic carbon (AOC) from the reaction with DOM. AOC is a key factor for the biological stability of a drinking water. Therefore, an overall assessment of the process has to be made with regard to beneficial and undesired effects of an oxidation process which are summarized in Fig. 25.

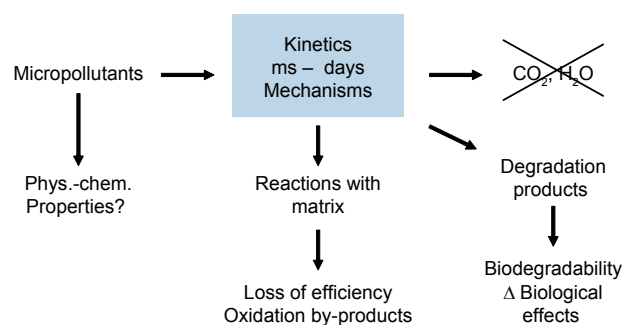

Fig. 25. Oxidation of micropollutants and undesired side-reactions.

OBJECTIVES

The objective of work package 2.1 was the assessment of an ozonation step within a pilot treatment train consisting of ozonation, biologically activated carbon filtration and ultrafiltration. The following investigations were carried out:

- Determination of second order rate constants for the reaction of selected taste and odor compounds with ozone and OH radicals (see work package 1.4).
- Transformation of DOM and formation of AOC during ozonation of filtered and algal cell enriched lake water in laboratory systems. Formation of AOC during the ozonation step in the pilot plant.
- Evaluation of an ozonation reactor with regard to micropollutant removal efficiency during conventional ozonation and the ozone-based AOP $\text{O}_3/\text{H}_2\text{O}_2$ for continuous operation and mitigation of accidental pollution of Lake Zurich water. This process was also assessed for disinfection efficiency and bromate formation.

- NDMA formation during ozonation of waters containing dimethylsulfamide.
- Design and characterization of the ozonation reactor by CFD modeling and tracer tests.
- Uncertainty and sensitivity analysis for micropollutant elimination during pilot-scale ozonation.
- Design of an ozone control system based on an online monitoring of the first-order ozone decay constant.

RESULTS AND DISCUSSION

DOM transformation and AOC formation during ozonation

It could be shown with SEC-OCD that DOM is transformed during ozonation and that there is a shift from higher to lower molecular weight compounds (work package 1.2). These compounds are mostly better available for microorganisms and part of this fraction is responsible for the AOC, which is related to biological stability of the finished drinking water. In the Swiss context with low or no residual disinfection, this parameter is crucial for the distribution of safe drinking water. AOC formation was investigated both in laboratory- and pilot-scale ozonation of filtered and algal cell enriched water. The AOC formation in the laboratory and on the pilot plant were well comparable (Fig. 26).

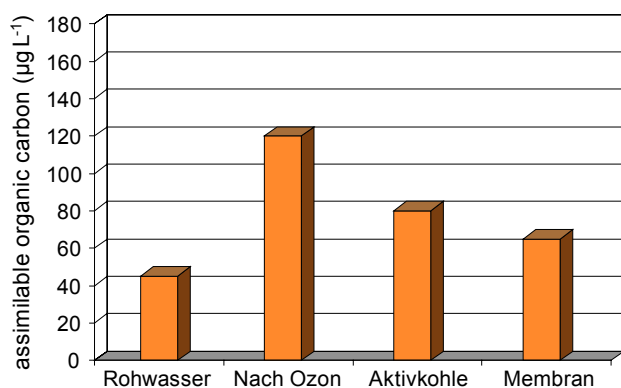
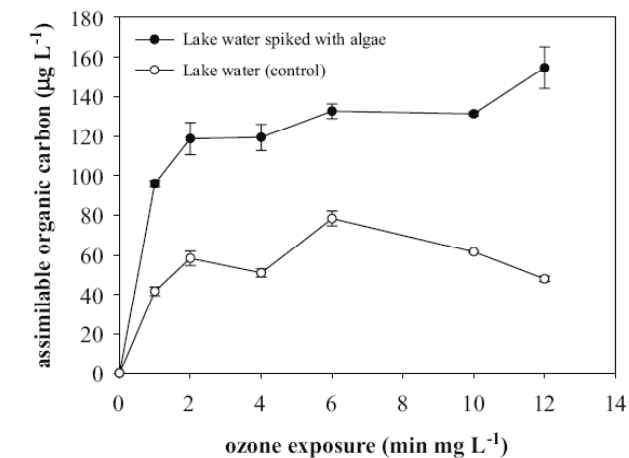

Fig. 26. AOC formation in laboratory and pilot experiment. (a) laboratory experiment with filtered Lake Zurich water and with the same water spiked with 2 mg/L *S. vacuolatus* (AOC formation as a function of the ozone exposure), (b) AOC formation during ozonation and decrease in the BAC in the Lake Zurich pilot plant.

It could be shown that only a fraction of the AOC can be formed from the oxidation of DOM during ozonation (Hammes et al., 2006). Much higher concentrations of AOC were formed from the oxidation of algal cells, probably due to the release of intracellular material (Hammes et al., 2007). The AOC formed from DOM could be well described by organic acids, whereas the algal-derived AOC was very different in composition. These findings have to be considered when placing an ozonation at the front of a treatment train. By way of oxidation of algal matter, this can lead to high AOC formation.

Oxidation of micropollutants

Several taste and odor compounds were selected from a list of compounds for which rate constants for their reaction with ozone and OH radicals have been measured (work package 1.4). The selection was based on the second order rate constant for the reaction with ozone. A compound with no, an intermediate and a high reactivity with ozone were selected. Fig. 27 shows the elimination of three selected T&O compounds during pilot-scale ozonation with Lake Zurich water.

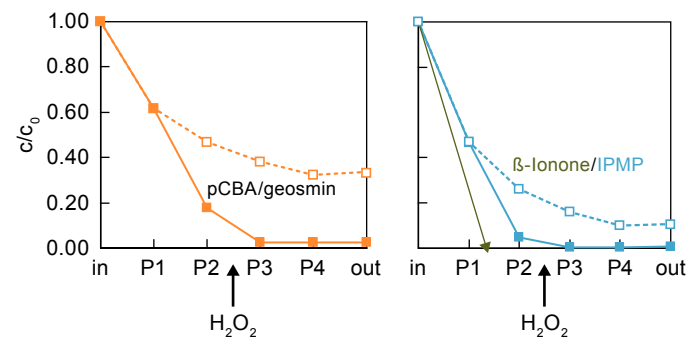

Fig. 27. Oxidation of geosmin, iso-propylmethoxy pyrazine (IPMP) and β -ionone during ozonation and the AOP O_3/H_2O_2 (Lengg pilot plant). Hydrogen peroxide was added between sampling point P2 and P3. Ozone dose 2.5 mg/L, hydrogen peroxide 0.85 mg/L, $IPMP_0$ 0.01 μM , $pCBA_0$ 1.5 μM . Solid lines conventional ozonation, dashed lines AOP O_3/H_2O_2 .

It can be seen that the rate and degree of elimination increases with increasing rate constant for the reaction of the target compound with ozone. β -ionone, the fastest reacting compound, is already fully eliminated prior to the first sampling point, whereas for a given ozone dose (2.5 mg/L), geosmin is eliminated by about 60% and IPMP by about 90% during conventional ozonation. This results from the difference in the rate constants for the direct reaction with ozone. If the AOP ozone/hydrogen peroxide is applied, these differences disappear almost entirely, because ozone is fully transformed into OH radicals between P2 and P3 leading to a full elimination of both compounds. Bromate, the main oxidation by-product of ozonation, was also investigated simultaneously to the elimination of T&O compounds. A concentration of nearly 10 $\mu g/L$ (drinking water standard) was found for an ozone dose of 2.5 mg/L, which is considerable, given that Lake Zurich contains only about 20 $\mu g/L$ bromide. Therefore, for higher bromide levels and/or ozone dos-

es, elimination of T&O can lead to a violation of the drinking water standard for bromate. In these cases bromate minimization strategies for ozonation or the more energy intensive process UV/H₂O₂ should be applied.

NDMA formation during ozonation

In a separate laboratory study the kinetics and mechanisms of NDMA formation during ozonation of dimethylsulfamide (DMS), a metabolite of the fungicide tolylfluanid, was investigated. This is one of the few cases for which a more toxic compound is formed from the oxidation of a micropollutant. It could be shown that under certain conditions as much as 50% conversion of DMS to NDMA could be reached for ozone exposures in the range of drinking water applications. A mechanism was proposed which included reaction steps requiring HOBr from the oxidation of bromide with ozone and ozone itself.

Ozonation reactor characterization

A CFD model was developed to optimize the reactor geometry of the ozonation reactor. This resulted in a four chamber reactor with integrated obstacles to guarantee almost ideal plug-flow behavior. This reactor was then characterized by a conservative tracer (fluorescein) with a multiport fluorometer. The reactor could be best characterized by a sequence of 10–30 continuous stirred-tank reactors (CSTRs). This means, that the CFD design was quite accurate to approach plug-flow behaviour (Gresch et al., 2009).

Uncertainty and sensitivity analysis

The uncertainty involved in predicting micropollutant decrease in the pilot ozonation reactor was evaluated (Neumann et al., 2009). Micropollutants including geosmin, MTBE, IPMP, be-

zafibrate, β-cyclocitral and ciprofloxazin which cover a wide range of representative reactivities with ozone (0.1–19'000 M⁻¹s⁻¹). The uncertainty ranges of the model factors are obtained from literature (rate constants), on-site data (ozone dose, ozone stability, ratio R_{ct} = [OH]/[O₃], temperature, reactor volume, hydraulics, etc.) and expert knowledge (e.g. activation energies). The cumulative probability distributions of the residual concentrations were obtained via Monte Carlo simulation. To examine which parameters are influential in determining output uncertainty, global sensitivity analysis by variance decomposition was performed. It could be seen that for compounds reacting slowly with ozone, parameters related to OH radical reactions (e.g. R_{ct}, rate constant for the reaction with OH radicals) for compounds reacting fast with ozone, parameters such as rate constants for the reaction with ozone and reactor hydraulics were most influential (Neumann et al., 2009).

Ozone control system by online measurement of k_{O₃}

A sequencing batch reactor (SBR) was installed to get an online measurement of the first order ozone decomposition rate constant. The system is shown in Fig. 28a and consists of a SBR (1) which is filled every 30 min with water that has been dosed with ozone in the pilot plant. Over a valve and a teflon tube (2, Fig. 28a), the ozonated water flows through an amperometric ozone detector (3, Fig. 28a) which monitors the ozone concentration as a function of time (4, Fig 28b) and enables to calculate the first order ozone decomposition rate constant (5, Fig 28b).

This system was implemented and run over several months. It can be used to get online data on ozone stability and OH radical formation and allows better predictions for disinfection and micropollutant oxidation. It is planned that this system will be applied to control ozone dosing for a certain disinfection target. It is currently implemented for the new Lengg pilot plant.

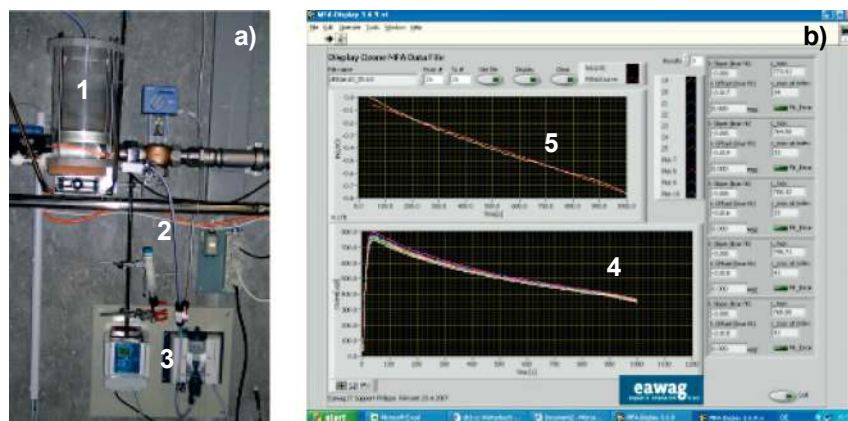

Fig. 28. SBR online system for the measurement of the ozone decomposition rate constant for ozonated pilot plant Lake water. 1: SBR, 2: valve and teflon tube, 3: amperometric ozone detection, 4: ozone decrease as a function of reaction time, 5: first order plot for ozone decomposition.

REFERENCES

- Acero, J.L., Haderlein, S.B., Schmidt, T.C., Suter, M. J.-F. and von Gunten, U. (2001) MTBE Oxidation by Conventional Ozonation and the Combination Ozone/Hydrogen Peroxide: Efficiency of the Processes and Bromate Formation. *Environ. Sci. Technol.* 35, 4252–4259.
- Acero, J.L., Stemmler, K. and von Gunten, U. (2000) Degradation kinetics of atrazine and its degradation products with ozone and OH radicals: A predictive tool for drinking water treatment. *Environ. Sci. Technol.* 34, 591–597.
- Buxton, G.V., Greenstock, C.L., Helman, W.P. and Ross, W.P. (1988) Critical review of rate constants for reactions of hydrated electrons, hydrogen atoms and hydroxyl radicals in aqueous solution. *J. Phys. Chem. Ref. Data* 17, 513–886.
- Dodd, M.C., Buffle, M.O. and Von Gunten, U. (2006) Oxidation of antibacterial molecules by aqueous ozone: Moiety-specific reaction kinetics and application to ozone-based wastewater treatment. *Environmental Science & Technology* 40(6), 1969–1977.
- Dodd, M.C. and Huang, C.H. (2004) Transformation of the antibacterial agent sulfamethoxazole in reactions with chlorine: Kinetics mechanisms, and pathways. *Environmental Science & Technology* 38(21), 5607–5615.
- Hammes, F., Meylan, S., Salhi, E., Koster, O., Egli, T. and Von Gunten, U. (2007) Formation of assimilable organic carbon (AOC) and specific natural organic matter (NOM) fractions during ozonation of phytoplankton. *Water Research* 41(7), 1447–1454.
- Hammes, F., Salhi, E., Koster, O., Kaiser, H.P., Egli, T. and von Gunten, U. (2006) Mechanistic and kinetic evaluation of organic disinfection by-product and assimilable organic carbon (AOC) formation during the ozonation of drinking water. *Water Research* 40(12), 2275–2286.
- Huber, M.M., Canonica, S., Park, G.Y. and Von Gunten, U. (2003) Oxidation of pharmaceuticals during ozonation and advanced oxidation processes. *Environmental Science & Technology* 37(5), 1016–1024.
- Huber, M.M., Ternes, T.A. and von Gunten, U. (2004) Removal of estrogenic activity and formation of oxidation products during ozonation of 17 alpha-ethinylestradiol. *Environmental Science & Technology* 38(19), 5177–5186.
- Onstad, G.D., Strauch, S., Meriluoto, J., Codd, G.A. and von Gunten, U. (2007) Selective oxidation of key functional groups in cyanotoxins during drinking water ozonation. *Environmental Science & Technology* 41(12), 4397–4404.
- Rodriguez, E., Onstad, G.D., Kull, T.P.J., Metcalf, J.S., Acero, J.L. and von Gunten, U. (2007) Oxidative elimination of cyanotoxins: Comparison of ozone, chlorine, chlorine dioxide and permanganate. *Water Research* 41(15), 3381–3393.
- Suarez, S., Dodd, M.C., Omil, F. and von Gunten, U. (2007) Kinetics of triclosan oxidation by aqueous ozone and consequent loss of antibacterial activity: Relevance to municipal wastewater ozonation. *Water Research* 41(12), 2481–2490.
- von Gunten, U. (2003) Ozonation of drinking water: Part I. Oxidation kinetics and product formation. *Water Res.* 37, 1443–1467.
- von Gunten, U. and Salhi, E. (2000) Bromat im Trinkwasser – ein Problem in der Schweiz? *Gas Wasser Abwasser* 80, 705–710.

WAVE21 PUBLICATIONS RELEVANT FOR THIS WORK PACKAGE

- Arnold W.A., Schmidt C. K., Salhi E., von Gunten U. Kinetics and Mechanisms of N-Nitroso- dimethylamine (NDMA) formation upon Ozonation of N, N-Dimethylsulfamide. in preparation.
- Gresch M., Brügger R., Meyer A., Gujer W. (2009) Compartmental models for continuous flow reactors derived from CFD simulations. *Environmental Science and Technology*, 43, 7, 2381–2387
- Hammes, F., Meylan, S., Salhi, E., Köster, O., Egli, T., von Gunten, U. (2007) Formation of assimilable organic carbon (AOC) and specific natural organic matter (NOM) fractions during ozonation of phytoplankton. *Water Research* 41, 1447–1454.
- Hammes, F., Salhi, E., Köster, O., Kaiser, H.P., Egli, T., von Gunten, U. (2006) Mechanistic and kinetic evaluation of organic disinfection by-product and assimilable organic carbon (AOC) formation during the ozonation of drinking water. *Water Research* 40, 2275–2286.
- Lutze H. (2007) Oxidative Elimination von Geruchs- und Geschmacksstoffen in der Trinkwasseraufbereitung, Masterarbeit, Universität Duisburg.
- Neumann M. B., Gujer W., von Gunten U. (2009) Global sensitivity analysis for model-based prediction of oxidative micropollutant transformation during drinking water treatment. *Water Res.*, 43, 4, 997–1004.
- Onstad, G., Strauch, S., Meriluoto, J., Codd, G. A., von Gunten U. (2007) Selective oxidation of key functional groups in cyanotoxins during drinking water ozonation. *Environ. Sci. Technol.*, 41, 4397–4404.
- Peter A. and von Gunten U. (2007) Oxidation kinetics of selected taste and odor compounds during ozonation of drinking water, *Environ. Sci. Technol.*, 41, 626–631.
- Peter A. (2008) Taste and odor in drinking water: Sources and mitigation strategies. Diss. ETH 17661.
- Ramseier M. K., von Gunten U. (2009) Mechanisms of phenol ozonation – kinetics of formation of primary and secondary reaction products. *Ozone Sci. Eng.*, 31, 3, 201–215.
- Rodriguez, E., Onstad, G. D., Kull, T. P. J., Metcalf, J. S., Acero, J. L., von Gunten, U. (2007) Oxidative elimination of cyanotoxins: comparison of ozone, chlorine, permanganate and chlorine dioxide. *Water Res.*, 41, 3381–3393.

2.2 MEMBRANE TECHNOLOGY

INTRODUCTION

In the last decade, the application of membrane technology in drinking water treatment has strongly increased. In Switzerland, this mainly applies to the process of ultrafiltration (UF). Numerous applications already exist for the treatment of lake waters and for the treatment of low-quality spring water such as karstic spring water, and a large number of membrane plants are being planned.

Membrane processes provide an absolute barrier for microorganisms, including parasites, bacteria and viruses. In contrast to sand filters, membranes have a relatively small footprint and are built in a modular way, which results in a high flexibility to extend or decrease the production capacity. A limitation of membrane technology is the loss of membrane performance due to the accumulation of aquatic constituents on and in the membrane, a process known as membrane fouling. Although significant efforts have been devoted to elucidate fouling mechanisms, the phenomenon is still far from being fully understood.

OBJECTIVES

A better understanding of fouling in UF is the central theme of this work package. To reach this goal, the role of different foulants, their mutual interactions in the raw water and during UF and the interactions with the membrane were investigated. The study focused on substances generally regarded as the main foulants of UF membranes, namely fractions of natural organic matter (NOM) and submicron particles. A pilot plant study evaluated the laboratory results and investigated long-term fouling as a function of raw water quality.

During the research it was found that fouling can result in the formation of gel or cake layers which can act as a secondary membrane and influence the retention of molecules which are much smaller than the membrane pores. Specific experiments were carried out with defined foulants and radioactively labelled micropollutants to investigate this type of retention.

RESULTS AND DISCUSSION

The role of raw water constituents for membrane fouling

Experiments were carried out with synthetic systems in which single compounds were added to pure water, and also with natural water systems. In the natural systems, fractions of natural organic matter (NOM) were characterized according to the method described in work package 1.2. Filtration experiments were carried out in a dead-end filtration laboratory system with alternating cycles of filtration and backwashing under conditions which are comparable to a large-scale plant.

The results have shown that polysaccharides and humic substances are the NOM fractions which cause the strongest membrane fouling. Polysaccharides were shown to foul the membranes mainly by a mechanism of pore blocking and cake/gel formation leading to large but mostly reversible permeability losses and to only little hydraulically irreversible fouling. Although only little irreversible fouling by pore blocking and/or

membrane adsorption occurs, it is assumed to have a large influence on long-term fouling. Humic substances were shown to cause less fouling than polysaccharides, but mainly severe, irreversible fouling due to membrane adsorption, which was partially reversible by chemical cleaning. It was shown that the irreversible fouling is strongly dependent on the concentrations of NOM (Jermann et al., 2007).

Inorganic submicron particles filtered alone were observed to cause only little, completely reversible fouling by formation of a loose, porous cake on the membrane surface. The underlying mechanism leading to a loose porous cake was particle aggregation in the suspension representing conditions as in natural lake waters (Jermann et al., 2009). Calcium was shown to be an important fouling factor. It increased the interactions between the NOM and the membrane and therewith aggravated the irreversible fouling and enhanced the fouling by polysaccharides.

The significance of foulant-foulant interactions during UF

Our mechanistic research on membrane fouling showed the importance of mutual influences between various foulants for improved understanding of fouling phenomena. Foulant-foulant interactions led to synergistic and antagonistic fouling effects. The combined fouling characteristics were determined by the ratio of the foulants, namely the NOM/particle and humic substance/polysaccharide ratios, and the presence of calcium (Jermann et al., 2008). The findings on the impact of substance interactions on fouling were combined in a conceptual fouling model. It explains synergistic fouling effects due to a) interplay of the individual fouling mechanisms via hydrophobic and electrostatic interactions, b) increased fouling layer associations due to NOM-membrane adsorption, c) interactions during fouling layer formation (e.g. steric interactions) and d) particle stabilization by NOM (Jermann et al., 2008). Furthermore, possible antagonistic fouling effects due to particle aggregation in the presence of calcium were exemplified. Fig. 29 illustrates the fouling mechanisms of humic acids and alginate, as well as the influence of calcium in a schematic way.

In addition, a semi-empirical resistance model was introduced to further explain the synergistic fouling effects between particles and NOM and to quantify them for the NOM and particle substances used (Jermann et al., 2008).

Pilot plant study

The laboratory results on the fouling by NOM and particles were largely verified with a pilot-scale study. This study showed that seasonal changes in water quality (e.g. during lake turn-over or algal bloom) have a major impact on fouling. Furthermore, it was shown that the placement of the ultrafiltration in the treatment chain has an important influence on the membrane permeability: The placement after the pre-filtration resulted in an average permeability decrease of $0.0158 \text{ L/m}^2/\text{h}^2$, while after the activated carbon filter the decrease amounted $0.00585 \text{ L/m}^2/\text{h}^2$. This clearly indicates that the treatment by ozonation and activated carbon has a positive effect on the membrane permeability. Therefore, it is recommended to foresee a possible floccula-

Substance combination	Fouling characteristics	Fouling mechanism	Fouling mechanism - graphic model
(a) Humic acid, no calcium	Low ΔJ medium reversibility (nRF), medium irreversibility (nIF)	Substantial adsorption onto the clean and fouled membrane surface and in the pores by hydrophobic interactions, fast initial adsorption.	
(b) Alginate, no calcium	Moderate to large ΔJ , high reversibility (nRF), low irreversibility (nIF)	Cake formation on the membrane by pore blockage, relatively reversible due to strong electrostatic repulsion, marginal adsorption.	
(c) Humic acid and calcium	Low ΔJ , low reversibility (nRF), high irreversibility (nIF)	Increased adsorption onto the membrane in the presence of calcium, calcium coils the humic acid molecule.	
(d) Alginate and calcium	Large ΔJ , high reversibility (nRF), low irreversibility (nIF)	Gel formation induced by calcium complexation of alginate, low adsorption.	
(e) Humic acid and alginate	Large ΔJ , medium reversibility (nRF), medium irreversibility (nIF)	Formation of a heterogeneous alginate cake with humic acid incorporated, adsorption of mainly humic acid onto the membrane.	
(f) Humic acid, alginate and calcium	Very large ΔJ , low reversibility (nRF), high irreversibility (nIF)	Formation of a heterogeneous alginate gel with humic acid incorporated, increased adsorption of mainly humic acid onto the membrane in the presence of calcium.	

Fig. 29. Mechanistic model of membrane fouling by humic acids, alginate and calcium (From: Jermann et al., 2007).

tion step as a pretreatment for ultrafiltration if the ultrafiltration is used as a first step (pilot experiments 2009).

Fouling potential of raw waters

Based on the above presented results four main parameters that determine the fouling potential of natural surface waters were elucidated:

The total amount of foulants

An important parameter is the total amount of foulants in the water. However, it is unreliable as a means of estimating fouling because large amounts of particles much larger than the membrane pores lead to insignificant long-term fouling.

The ratio of NOM/particles

An increased amount of NOM in solution generally leads to increased irreversible fouling. The ratio NOM/particles influences both, the amount of free NOM and the amount of NOM adsorbed onto particles. An increased NOM/particle ratio leads to increased compactness (lower hydraulic permeability) of fouling layers which is related to increased particle stabilization and decreased fouling layer porosity due to the presence of NOM in the fouling layer. At a constant NOM concentration, an increased particle content leads to less resistance by decrease of the free NOM concentration and by the higher resistance of the NOM/particle complexes.

The ratio of humic substances/polysaccharides

A higher ratio of humic substances/polysaccharide leads to increasing irreversible fouling. A decrease of this ratio due to an increase in the polysaccharide concentration indicates an increase in reversible fouling.

Calcium concentration

Calcium can decrease reversible fouling due to aggregation of NOM-coated particles but it increases irreversible NOM fouling.

Therefore, high calcium concentrations (high hardness) indicate a higher long-term fouling potential.

The role of these four parameters for fouling is shown in Fig. 30 which can be used as a guide to predict fouling by different surface waters. For example spring waters have typically low NOM/particle ratios, whereas lake waters have rather larger NOM/particle ratios. Generally the humic substances/polysaccharides ratio (HS/PS) in lake water is largely influenced by algal blooms.

Influence of NOM on the retention of micropollutants

Although the pore size of ultrafiltration membranes is considerably larger than the molecular diameter of micropollutants, membrane fouling can cause retention of such compounds. In a study with radio-labelled compounds, it was shown that compounds which block the membrane surface by cake or gel layer formation (e.g. alginate, Aldrich Humic Acid) had a greater impact on the retention than foulants which interact with the membrane in an adsorptive manner (e.g. Nordic HA) (Jermann et al., submitted). With high concentrations of alginate (40 mg C/L), up to 40% retention of estradiol was observed. However, also with more realistic foulant concentrations (1 mg C/L) some retention was observed (in the order of 5–10%).

Implications for fouling control strategies

Forward flush/backwash is very effective for the removal of reversible fouling: Particles larger than the membrane pores and polysaccharides, for instance in water with a low NOM/particle and/or a low humic substance/polysaccharide ratio. Forward flush may even replace part of the backflush in order to save permeate water and thus increase process yield. Measuring UF fouling parameters is the basis to predict the fouling of a given water source. Turbidity as a parameter for the amount of particulate matter, DOC as parameter for the dissolved macromolecular NOM and calcium are usually measured. Additional

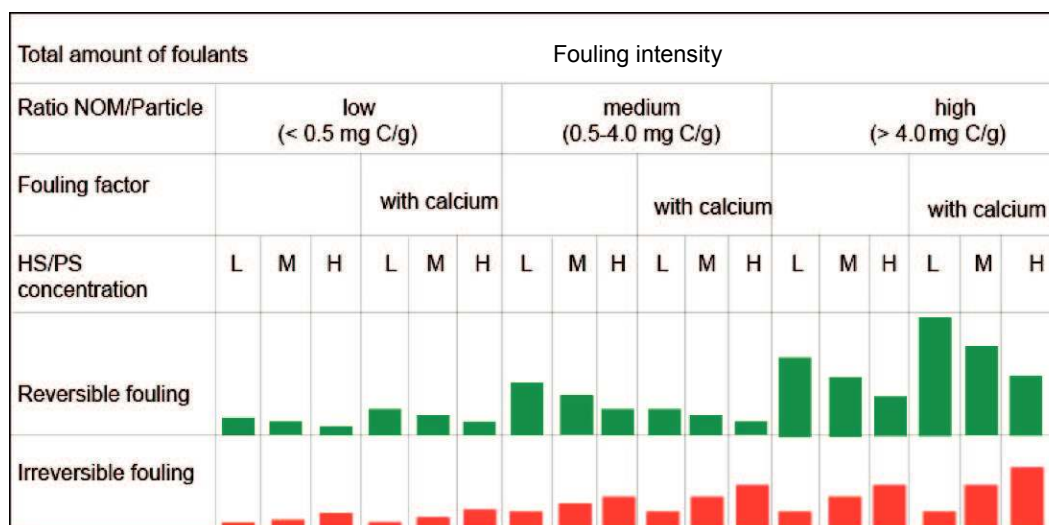

Fig. 30. Relative influence of raw water parameters (NOM/particle ratio, humic substances/polysaccharides (HS/PS) ratio and the presence of calcium) on fouling. L=Low, M=medium, H=high. (Jermann et al., 2008).

consideration of the turbidity/DOC ratio and humic substances/polysaccharide ratio could improve fouling predictions. Humic substances/polysaccharide ratios could be assessed by off-line analyses. Pre-treatment to reduce the UF fouling has to focus on the elimination of the NOM that causes fouling. This involves in particular the elimination of humic substances to reduce irreversible fouling and of polysaccharides to reduce reversible and irreversible fouling. The main option is therefore to use flocculation. It has the advantage that it can be used intermittently and seasonally.

WAVE21 PUBLICATIONS RELEVANT FOR THIS WORK PACKAGE

- Jermann D., Pronk W., Boller M., (2007) Interplay of different NOM fouling mechanisms during ultrafiltration for drinking water production, *Water Research*, 41 (8), 1713–1722
- Jermann D., Pronk W., Kägi R., Schaarschmidt N., Halbeisen M., Boller M., (2008), "Influence of interactions between NOM and particles on UF fouling mechanisms" *Water Research*, 42 (14), 3870–3878
- Jermann D., Pronk W., Boller M., (2008) Mutual influences between NOM and inorganic particles and their combined effect on UF membrane fouling, *Environ. Sci. Technol.*, 42, 24, 9129–9136
- Jermann D., Pronk W., Boller M., Schäfer A.I., (2009) The role of NOM fouling for the retention of micropollutants, *Journal of Membrane Science*, 329, 1–2, 75–84.
- Jermann D., Pronk W., Boller M. (2008) Membranfouling. Forschungsergebnisse zu den Mechanismen. *GWA* 1, 1–8.

2.3 ADSORPTION PROCESSES

INTRODUCTION

In Switzerland, granular activated carbon (GAC) filters are used in most modern water works treating surface waters. GAC filters are usually employed as polishing treatment mainly for adsorption of micropollutants and as biological filter.

In recent years, GAC filters were mostly combined with a pre-ozonation step where substantial fractions of organic substances are oxidized to biodegradable compounds and further biologically degraded in GAC filters (Lee et al., 1981; Servais et al., 1991; Velten et al., 2007; Hammes et al., 2008). The latter step, also called biofiltration, is a biofilm process which stabilizes drinking water biologically, i. e. it prevents considerable bacterial re-growth during distribution. Biofiltration avoids the manifold quality problems associated with biological instability; high chlorine doses, disinfection by-products, accelerated corrosion, taste and odour compounds (T&O), high turbidity, and increased numbers of coliforms (Rittmann and Stilwell, 2002).

OBJECTIVES

The goals of this work package were to determine the significance of GAC filtration within future process schemes for drinking water treatment, including membranes and ozonation. The focus was upon biological activity and adsorption capacity for natural organic material (NOM) and micropollutants, with the objective to provide further insight for the improvement of process reliability and effectiveness of GAC filters.

Activated carbon (AC) treatment fulfils mainly three different tasks, namely particle separation (1), adsorption (2) and fixed-bed biofiltration (3). Within the framework of Wave21, all three functions were investigated with the following tasks:

(1) Particle separation

- Online monitoring of particles in the influent and effluent of the GAC column.

(2) Adsorption

- Determining the adsorption behaviour of different NOM fractions during the start-up phase and the pseudo-steady state operation of the GAC filter (link to work package 1.2).
- Removal of taste and odor (T&O) compounds during the start-up phase and the pseudo-steady state operation of the GAC filter (link to work package 1.4).
- Performing step dosing experiments with various tracer substances in order to derive the hydraulic properties of the GAC and its adsorption capacity for different compounds. These tracer experiments were performed during the start-up phase and the pseudo-steady state operation of the GAC filter.
- Creating a numerical model capable of reproducing and forecasting the adsorption capacity of a GAC filter as a function of the operation time.

(3) Fixed-bed biofiltration

- Developing and testing a new method for measuring adenosine triphosphate (ATP) and establishing the link between ATP and number of cells on GAC, thus allowing the computation of total biomass and its activity in the filter (link to work package 1.1).
- Applying this ATP method to investigate both the start-up phase and the pseudo-steady state of a GAC filter (later on a biologically active carbon filter: BAC) with respect to microbiological activity (link to work package 1.4 and work package 1.5).
- Analyzing the population of microbial strains by use of DNA analysis to investigate the link between appearance of specific species and functionality of the GAC filter. These experiments were performed during the start-up phase and the steady state operation of the GAC filter (link to work package 1.1).
- Investigating the influence of different operation regimes on the functionality of the GAC filter by frequent measurement of water quality parameters such as nitrate, oxygen, ammonium, AOC and pH, among others (close collaboration with the laboratory of the water utility of Zurich, WVZ).

RESULTS AND DISCUSSION

The knowledge generated within Wave21 contributes to the understanding of: (1) particle separation capacity of GAC filters; (2) the discussion of the role of GAC filters as adsorbers for NOM and micropollutants; and (3) biofilm development and stratifications over time in GAC filters (using the newly developed method based on ATP measurements).

Particle separation

Analyses of these data confirm that the GAC filter performs similarly as a rapid sand filter. It removes more than 50 % of the turbidity and about 20–90 % of the particles, depending on the size of the particles and the input load (link to work package 1.3). The particle concentration in the effluent of the GAC filter remains rather constant, creating in this way stable conditions for the membrane filter downstream (link to work package 2.2). The GAC filter performs significantly better as particle separator if the ozonation preceding it is in operation, because of the micro-flocculation observed in the ozone reaction chamber. The particles remaining in the water, whether created in the filter or not retained, are of little concern in this particular treatment train because of the ultrafiltration which acts as a final barrier for particles (work package 2.2).

Adsorption

Both micropollutants and NOM (expressed as DOC) are adsorbed on the GAC filter. In surface waters, the concentrations of NOM exceed by far the concentrations of micropollutants and thus the saturation of the GAC filter with NOM is faster than with micropollutants. In this context, the concurrent adsorption of micropollutants and NOM is crucial. Because of the usually unknown composition of NOM it is impossible to predict the competitive adsorption capacity theoretically. Isotherm experiments

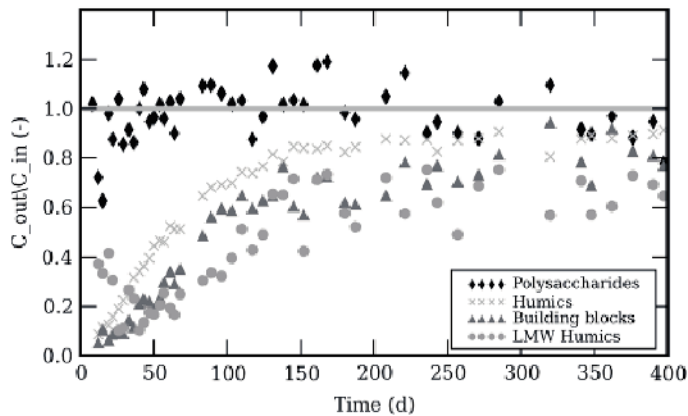

Fig. 31. Activated carbon filter in the pilot plant: Outflow over inflow concentration of selected NOM fractions as a function of the operation time.

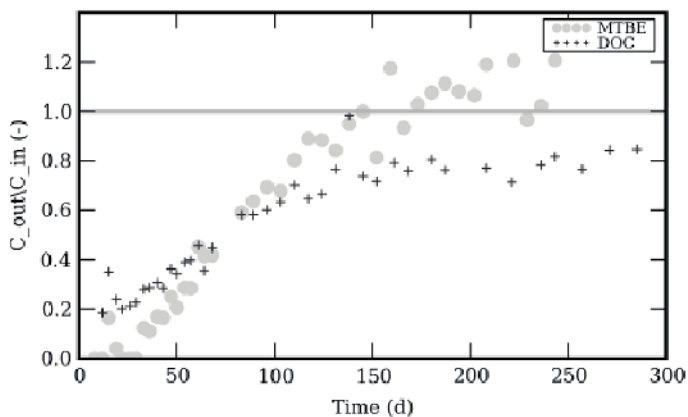

Fig. 32. Activated carbon filter in the pilot plant: Concentrations of MTBE and DOC as a function of the operation time.

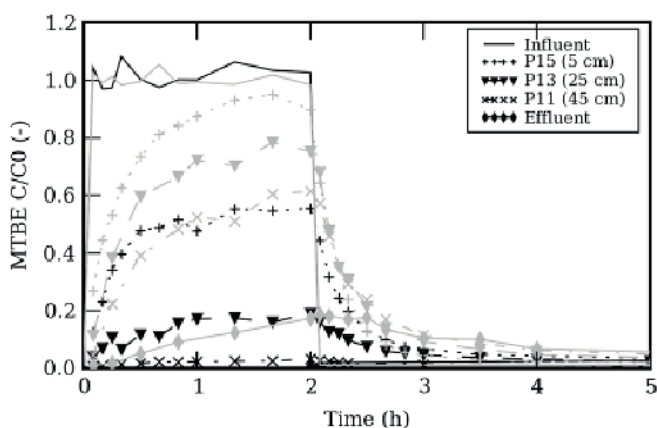

Fig. 33. Activated carbon filtration at the pilot plant: Relative MTBE concentrations over time for a step dosing experiment lasting two hours. The first experiment was performed on 19 October 2006 (black; 7 days of operation) and the second one on 14 July 2007 (grey; 245 days of operation).

with Isopropyl-methoxy-pyrazin (IPMP, a T&O compound, work package 1.4) as trace substance and both nanopure and surface water, respectively, revealed a six-fold reduction of the adsorption capacity in presence of NOM. For pre-used GAC the capacity is even further reduced relative to fresh GAC. These data are crucial input data for numerical modelling.

The methods developed in work package 1.2 allow to characterize NOM. It was shown that its composition changes within the GAC filter and also in the course of its operation. During the start-up phase mainly polysaccharides passed the filter, whereas most other NOM fractions were adsorbed (see Fig. 31). After approximately 200 days of operation, the filter was saturated with NOM and the effluent concentrations of all NOM fractions were within 80–100% of the influent concentration (see Fig. 31). The residual reduction of some NOM fractions is mainly due to biological processes. The percentage removal thus depends strongly on the biodegradability of the NOM fraction. These data are of crucial importance as input to the subsequent membrane filtration, as different fractions of NOM have different fouling potential (see work package 2.2).

The adsorption capacity of the GAC filter with respect to MPs was investigated measuring Methyl-tert-butylether (MTBE (work package 1.5)) as a trace substance. During the start-up phase (fresh GAC), 100% of MTBE is adsorbed. After about 30 days of operation, the effluent concentration of MTBE starts to increase until after approximately 150 days it reaches the influent concentration (see Fig. 32). At this stage, the filter is saturated with MTBE at a level corresponding to the steady state for a given inflow concentration. Step dosing experiments with MTBE simulating an accidental spill (see Fig. 33), proved that the saturated GAC is still capable of removing 60–80% of MTBE. The breakthrough curve depends strongly on the flow rate. The filter can thus provide protection from accidental spills even if saturated, giving the authorities time to shut down the plant and replace the GAC. Measurements of pore size distribution of fresh and used GAC showed that for the adsorption of MTBE the pores with a diameter ranging from 5.2–5.7 Å are of major importance.

If the ultimate purpose of the GAC filters is adsorption, the carbon needs to be replaced or reactivated frequently in order to maintain sufficient adsorption capacity. Alternatively, some waterworks use the GAC over an extended time period (up to 20 years), where the ultimate focus shifts from adsorption to biological filtration.

Fixed bed biofiltration

GAC filtration continues to remove organics far beyond the point at which the adsorption capacity would normally be exhausted. It has been suggested that this removal is the result of microbial activity at the external surface and in the macropores of the GAC granules. To be able to investigate the entire balance of microbiological activity in the filter, new techniques for measuring AOC and ATP were developed and extensively tested (See work package 1.1 and work package 1.2). Kinetic parameters such as growth rates and DOC and AOC removal rates were quantified. Quantitative knowledge of the system allows optimization in design, operation, monitoring and helps to develop models describing these systems.

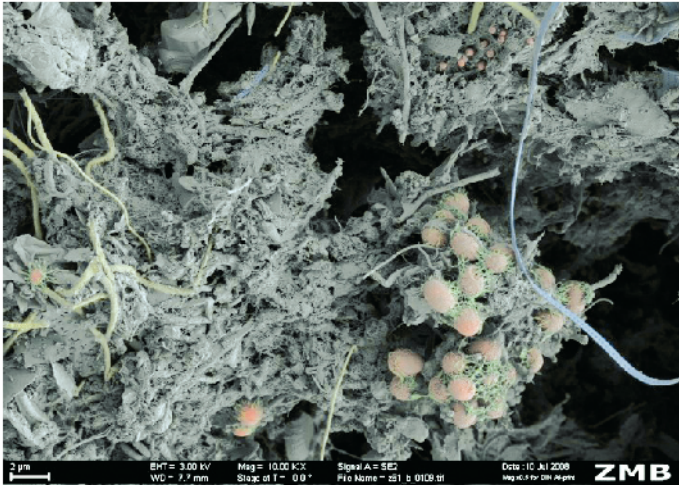

Fig. 34. Coloured scanning electron microscope image of the biofilm on a granular activated carbon (GAC) particle from the pilot plant. At the time of the picture, the GAC has been in use for approximately 6 months without any backwashing. Orange: bacterial cells; green web: extracellular polymeric substances.

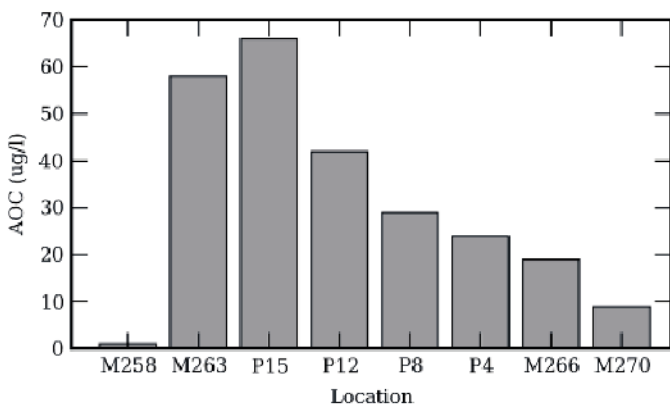

Fig. 35. Pilot plant for >30 days of operation: Concentrations of AOC at the different sampling points over the entire treatment train (M258: inlet, M263: after ozonation, GAC: P15: 5 cm; P12: 35 cm, P8: 75 cm, P4: 115 cm, M266: GAC effluent, M270: after ultra-filtration).

During the dynamic phase, growth in the filter leads to an increase in biomass, both biofilm and planktonic cells. Fig. 34 shows a coloured scanning electron microscope image of the biofilm on a granular activated carbon (GAC). During steady-state, however, a significant fraction of the continuously formed biomass is washed out and either requires additional treatment (e.g. filtration and/or chlorination) or is distributed directly to the consumer without treatment. Stratification of biomass concentration both in the start-up phase and the pseudo-steady state phase was clearly observed in different layers. Furthermore, different growth rates for biomass on GAC were calculated as a function of time and space. The dependency of the evolution of planktonic cells in the effluent of the GAC filter on the available carbon in the inflow was described (Velten 2008, Velten et al., in preparation).

A key control parameter for growth of bacteria is AOC. Measurements revealed that AOC is generated during ozonation of surface waters (see work package 2.1). The highest value of AOC is even recorded in the upper most layer of the GAC filter (see Fig. 35). This can be explained by the residual ozone after the contact chamber reacting with biomass accumulated at the top of the filter bed and thus leaching out of AOC. To achieve biologically stable water it is necessary to reduce the AOC concentration below a certain threshold. The BAC filter of the pilot plant showed to be efficient in consuming AOC from its influent water (see Fig. 35) and as such to meet the requirements for biologically stable water (see work package 1.1).

REFERENCES

- Lee M.C., Snoeyink V.L. and Crittenden J.C. (1981) Activated Carbon Adsorption of Humic Substances. *Journal American Water Works Association*, 73(8), 440–446.
- Rittmann B.E. and Stiwell D. (2002) Modelling biological processes in water treatment: The integrated biofiltration model. *Journal of Water Supply: Research and Technology – AQUA*, 51(1), 1–14.
- Servais P., Billen G., Ventresque C., and Bablon G.P. (1991) Microbial Activity in Gac Filters at the Choisy-Le-Roi Treatment-Plant. *Journal American Water Works Association*, 83(2), 62–68.

WAVE21 PUBLICATIONS RELEVANT FOR THIS WORK PACKAGE

- Boller M., Velten S., Peter A., Hammes F., Helbing J. (2008) Trinkwasseraufbereitung mit Aktivkohle. *Neue Erkenntnisse*. GWA 1, 1–9.
- Hammes F., Berney M., Wang Y., Vital M., Koster O., and Egli T. (2008) Flow-cytometric total bacterial cell counts as a descriptive microbiological parameter for drinking water treatment processes. *Water Research*, 42(1–2), 269–277.
- Velten S., Hammes F., Boller M., and Egli T. (2007) Rapid and direct estimation of active biomass on granular activated carbon through adenosine tri-phosphate (ATP) determination. *Water Research*, 41(9), 1973–1983.
- Velten S. (2008) Adsorption Capacity and Biological Activity of Biological Activated Carbon Filters in Drinking Water Treatment. PhD Thesis ETH.
- Velten, S., Knappe, D.R.U., Traber, J., Kaiser, H.-P., von Gunten, U., Boller, M., Meylan, S. Characterization of natural organic matter adsorption in granular activated carbon adsorbents, submitted to *Environmental Science & Technology*.
- Velten, S., Boller, M., Kaiser, H.-P., Knappe, D.R.U., Effects of natural organic matter preloading on physical characteristics and remaining MTBE adsorption capacity of granular activated carbon, proc. 4th IWA Young Professionals Conference, Berkeley, CA, USA, July 2008.
- Velten, S., Strübing, D., Peter, A., Boller, M., Removal of 2-Isopropyl-3-methoxy-pyrazine (IPMP) with granular activated carbon: from lab scale to pilot scale, Chapter 5 in Dissertation S. Velten.
- Velten, S., Meylan, S., Boller, M. and Knappe, D.R.U. Surface area measurements provide an insufficient estimate for MTBE adsorption capacity of granular activated carbon, in preparation.

3 OUTLOOK AND RECOMMENDATIONS

FUTURE DRINKING WATER ACTIVITIES

Traditionally, drinking water topics in a broader sense were not dealt with at Eawag. The Swiss water industry was oriented towards the TZW in Karlsruhe. The cross-cutting project Wave21 allowed establishing drinking water as a main research topic at Eawag. Wave21 was a catalyst to start up an active drinking water group with strong basic and applied research at Eawag. This project fostered the collaboration between chemists, microbiologists and engineers at Eawag and scientists and practitioners from the outside. The direct collaboration with the water supply Zurich (WVZ) and the engineering company Wabag gave many impulses to Wave21 and was also a link to practice. This enabled know-how transfer and also outreach to other water utilities. Furthermore, the advisory board, composed of representatives

from all stakeholders involved in drinking water (BAG, BAFU, SVGW, Water utilities, water industry) was an important catalyst to enable further collaborations in practice. The Wave21 project has also attracted 6 scientist from abroad to spend a sabbatical at Eawag. Last but not least, a seminar series (Statusseminare) was established and attracted more than 100 practitioners every year. Fig. 36 shows the cover of the flyers of these attractive one day events. This initiative enabled Wave21 to build up a community of practitioners which bridges between research and practical application.

The momentum of this successful collaboration between researchers, water supplies and practitioners should be utilized for a continuation of these activities. A new Competence Center for Drinking Water (CCDW) is currently under discussion at Eawag and will enable the continued research, teaching and consulting in the field of drinking water science and technology.



Fig. 36. Cover of the flyers of the three Wave21 “Statusseminare”, 2005–2007, and the joint Eawag-Wave21 Infotag 2008.

4 LIST OF WAVE21 PUBLICATIONS

Peer reviewed publications

- BERNEY, M., HAMMES, F., BOSSHARD, F., WEILENMANN, H.-U., AND EGLI, T. Assessment and interpretation of bacterial viability by using the LIVE/DEAD(C) BacLight™ kit in combination with flow cytometry. *Applied and Environmental Microbiology* 73, 10 (2007), 3283–3290.
- BERNEY, M., VITAL, M., HÜLSHOFF, I., WEILENMANN, H. U., EGLI, T., AND HAMMES, F. Rapid cultivation independent assessment of microbial viability in drinking water. *Water Research* 42, 14 (2008), 4010–4018.
- GRESCH, M., BRÜGGER, R., MEYER, A., AND GUJER, W. Compartmental models for continuous flow reactors derived from CFD simulations. *Environmental Science and Technology* 43, 7 (2009), 2381–2387.
- HAMMES, F., BERNEY, M., WANG, Y., VITAL, M., KÖSTER, O., AND EGLI, T. Flow-cytometric total bacterial cell counts as a descriptive microbiological parameter for drinking water treatment processes. *Water Research* 42, 1 (2008), 269–277.
- HAMMES, F., AND EGLI, T. New method for assimilable organic carbon determination using flow-cytometric enumeration and a natural microbial consortium as inoculum. *Environmental Science and Technology* 39, 9 (2005), 3289–3294.
- HAMMES, F., MEYLAN, S., SALHI, E., KÖSTER, O., EGLI, T., AND VON GUNTEN, U. Formation of assimilable organic carbon (AOC) and specific natural organic matter (NOM) fractions during ozonation of phytoplankton. *Water Research* 41, 7 (2007), 1447–1454.
- HAMMES, F., SALHI, E., KÖSTER, O., KAISER, H.-P., EGLI, T., AND VON GUNTEN, U. Mechanistic and kinetic evaluation of organic disinfection by-product and assimilable organic carbon (AOC) formation during the ozonation of drinking water. *Water Research* 40, 12 (2006), 2275–2286.
- JERMANN, D., PRONK, W., AND BOLLER, M. Membranfouling. *Forschungsergebnisse zu den Mechanismen. GWA. Gas, Wasser, Abwasser* 88, 1 (2008), 37–44.
- JERMANN, D., PRONK, W., AND BOLLER, M. Mutual influences between natural organic matter and inorganic particles and their combined effect on ultrafiltration membrane fouling. *Environmental Science and Technology* 42, 24 (2008), 9129–9136.
- JERMANN, D., PRONK, W., BOLLER, M., AND MEYLAN, S. Interplay of different NOM fouling mechanisms during ultrafiltration for drinking water production. *Water Research* 41, 8 (2007), 1713–1722.
- JERMANN, D., PRONK, W., BOLLER, M., AND SCHÄFER, A. The role of nom fouling for the retention of estradiol and ibuprofen during ultrafiltration. *Journal of Membrane Science* 329, 1–2 (2009), 75–84.
- JERMANN, D., PRONK, W., KAEGI, R., HALBEISEN, M., AND BOLLER, M. Influence of interactions between nom and particles on uf fouling mechanisms. *Water Research* 42, 14 (2008), 3870–3878.
- KAEGI, R., WAGNER, T., HETZER, B., SINNET, B., TZVETKOV, G., AND BOLLER, M. Size, number and chemical composition of nanosized particles in drinking water determined by analytical microscopy and LIBD. *Water Research* 42, 10–11 (2008), 2778–2786.
- MEYLAN, S., HAMMES, F., TRABER, J., SALHI, E., VON GUNTEN, U., AND PRONK, W. Permeability of low molecular weight organics through nanofiltration membranes. *Water Research* 41, 17 (2007), 3968–3976.
- NEUMANN, M., GUJER, W., AND VON GUNTEN, U. Global sensitivity analysis for model-based prediction of oxidative micropollutant transformation during drinking water treatment. *Water Research* 43, 4 (2009), 997–1004.
- PETER, A. Advanced organoleptic analysis of T&O compounds. *Technau Newsletter* 3 (2007).
- PETER, A., KÖSTER, O., SCHILDKNECHT, A., AND VON GUNTEN, U. Occurrence of dissolved and particlebound taste and odor compounds in Swiss lake waters. *Water Research* 43, 8 (2009), 2191–2200.
- PETER, A., AND VON GUNTEN, U. Oxidation kinetics of selected taste and odor compounds during ozonation of drinking water. *Environmental Science and Technology* 41, 2 (2007), 626–631.
- PETER, A., AND VON GUNTEN, U. Taste and odor problems generated in distribution systems – a case study about the formation of 2,4, 6-trichloroanisole. *Journal of Water Supply: Research and Technology-AQUA* 56, 6 (2009), 386–394.
- PRONK, W., SINNET, B., MEYLAN, S., AND BOLLER, M. Characterization of nano- and microparticles in Swiss waters and their role in potable water production. *Water Science and Technology: Water Supply* 6, 1 (2006), 21–29.
- RAMSEIER, M., AND VON GUNTEN, U. Mechanisms of phenol ozonation - kinetics of formation of primary and secondary reaction products. *Ozone: Science & Engineering* 31, 3 (2009), 201–215.
- SIEBEL, E., WANG, Y., EGLI, T., AND HAMMES, F. Correlations between total cell concentration, total adenosine tri-phosphate concentration and heterotrophic plate counts during microbial monitoring of drinking water. *Drinking Water Engineering and Science* 1, 1 (2008), 1–6.
- VELTEN, S., HAMMES, F., BOLLER, M., AND EGLI, T. Rapid and direct estimation of active biomass on granular activated carbon through adenosine tri-phosphate (ATP) determination. *Water Research* 41, 9 (2007), 1973–1983.
- VITAL, M., HAMMES, F., AND EGLI, T. *Escherichia coli* O157 can grow in natural freshwater at low carbon concentrations. *Environmental Microbiology* 10, 9 (2007), 2387–2396.
- WANG, Y., HAMMES, F., BOON, N., CHAMI, M., AND EGLI, T. Cultivation, isolation and characterization of low nucleic acid (LNA) content bacteria from various freshwater environments. *Microbial Ecology online* (2009).
- WANG, Y., HAMMES, F., BOON, N., AND EGLI, T. Quantification of the filterability of freshwater bacteria through 0.45, 0.22, and 0.1 µm pore size filters and shape-dependent enrichment of filterable bacterial communities. *Environmental Science and Technology* 41, 20 (2007), 7080–7086.
- WANG, Y., HAMMES, F., DÜGGELIN, M., AND EGLI, T. Influence of size, shape, and flexibility on bacterial passage through micropore membrane filters. *Environmental Science and Technology* 42, 17 (2008), 6749–6754.

Publications in preparation

- HAMMES, F., BERGER, C., KÖSTER, O., AND EGLI, T. Biological stability of drinking water without disinfectant residuals: a case study of Zurich water supply system. in preparation (2009).
- HELBING, J., VON GUNTEN, U., AND GRESCH, M. Fluorescein as an easy to use tracer for analysis of treatment trains. in preparation (2009).
- VELTEN, S., BOLLER, M., AND HAMMES, F. Biomass development and stratification during the start-up phase of a granular activated carbon (GAC) filter. in preparation (2009).
- VELTEN, S., KNAPPE, D., AND BOLLER, M. Changes in physical characteristics and MTBE adsorption capacity of granular activated carbon during operation of a pilot-scale adsorber. in preparation (2009).
- VELTEN, S., TRABER, J., HAMMES, F., KNAPPE, D., VON GUNTEN, U., BOLLER, M., AND MEYLAN, S. Evolution of natural organic matter adsorption on granular carbon in packed bed reactors. in preparation (2009).

Other publications

- BOLLER, M., VELTEN, S., PETER, A., HAMMES, F., AND HELBING, J. Trinkwasseraufbereitung mittels Aktivkohle: Neue Erkenntnisse. GWA. Gas, Wasser, Abwasser 88, 1 (2008), 27–35.
- BOON, N., WITTEBOLLE, L., VELTEN, S., TRABER, J., KÖSTER O., AND F. HAMMES. Stratification in a granular activated carbon reactor determines microbial community composition, dynamics and activity. 12th International Symposium on Microbial Ecology. Cairns, Australia, August (2008), 1722.
- VELTEN, S., BOLLER, M., EGLI, T., AND HAMMES, F. ATP measurement as a means for directly estimating active biomass. *Promega Notes* 97 (2007), 15–17.

Eawag publications

- EGLI, T., BERNEY, M., HAMMES, F., AND FÜCHSLIN, H. P. Neue Methoden zur Beurteilung der Trinkwasserhygiene. *Eawag News* 65d (2008), 20–23.
- LUTZE, H., PETER, A., AND VON GUNTEN, U. Wenn das Trinkwasser modrig riecht. *Eawag aquatic research; Jahresbericht 2007* (2008), 47.
- MÜCK, E., BOSSHART, U., KAISER, H.-P., AND KÖSTER, O. Zusammenspiel von Forschung und Praxis. *Eawag News* 65d (2008), 32–35.
- PETER, A., AND VON GUNTEN, U. Organische Spurenstoffe eliminieren. *Eawag News* 65d (2008), 24–27.
- PRONK, W., AND KAISER, H.-P. Trinkwasseraufbereitung der Zukunft. *Eawag News* 65d (2008), 28–31.
- PRONK, W., AND VON GUNTEN, U. Membrane filters for safe drinking water. *Eawag aquatic research; Jahresbericht 2008* (2009), 10–14.
- VON GUNTEN, U. Gutes Trinkwasser – eine Selbstverständlichkeit? *Eawag News* 65d (2008), 4–7.

PhD thesis

- JERMANN, D. Membrane fouling during ultrafiltration for drinking water production: causes, mechanisms and consequences. PhD thesis, ETH-Zurich, 2008. No.: 17811.
- PETER, A. Taste and odor in drinking water: Sources and mitigation strategies. PhD thesis, ETH-Zurich, 2008. No.: 17661.
- VELTEN, S. Adsorption Capacity and Biological Activity of Biological Activated Carbon Filters in Drinking Water Treatment. PhD thesis, ETH-Zurich, 2008.
- WANG, Y. The unseen majority: Heterotrophic bacteria in freshwater. More than just small and non-cultivable. PhD thesis, ETH-Zurich, 2008. No.: 17894.

Master thesis

- BRÜGGER, R. Identifizierung von Reaktormodellen auf Basis von CFD Simulationen. Master's thesis, ETHZ, 2007.
- DE GIOVANETTI, L. Drinking water production with membranes from seawater and wastewater. Master's thesis, ETHZ, 2007.
- HÜLSHOFF, I. Rapid flow-cytometric analysis of natural bacteria in drinking water. Master's thesis, Universität Duisburg, 2006.
- LUTZE, H. Oxidative Elimination von Geruchs- und Geschmacksstoffen in der Trinkwasseraufbereitung. Master's thesis, Universität Duisburg, 2008.
- MATTER, C. Trinkwasseraufbereitung von Seewasser mittels Ultrafiltration. Master's thesis, ETHZ, 2007.
- SIEBEL, E. Drinking water microbial analysis and the characterization of low nucleic acid (LNA) content bacteria from freshwater. Master's thesis, Universität Duisburg, 2007.

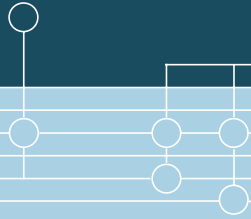

Eawag
Überlandstrasse 133
P.O. Box 611
8600 Dübendorf
Switzerland
Phone +41 (0) 44 823 55 11
Fax +41 (0) 44 823 50 28
www.eawag.ch