

# Wavelength reuse in a bidirectional UWB over fiber system

Tong Shao and Jianping Yao\*

Microwave Photonics Research Laboratory, School of Electrical Engineering and Computer Science, University of Ottawa, Ottawa, K1N 6N5, Canada  
\*jpyao@eecs.uottawa.ca

**Abstract:** Wavelength reuse in a bidirectional UWB over fiber system using a polarization modulator (PolM) and an electro-absorption modulator (EAM) is proposed and experimentally demonstrated. Since the PolM functions as a special phase modulator that supports phase modulation along the two principal axes with opposite modulation indices and the EAM is a polarization-independent component, the signals due to the phase-modulation to intensity-modulation (PM-IM) conversion along the two orthogonal directions in the upstream link will be complementary and cancelled out, thus the impact of the downstream signal to the upstream transmission due to the PM-IM conversion is fully eliminated. Error-free bidirectional transmission of a 1.25-Gbps UWB signal over 17 km single-mode fiber (SMF) is demonstrated. A power penalty due to the wavelength reuse for upstream transmission is measured to be as low as 0.2 dB.

©2013 Optical Society of America

**OCIS codes:** (060.0060) Fiber optics and optical communications; (060.5625) Radio frequency photonics.

---

## References and links

1. G. R. Aiello and G. D. Rogerson, "Ultra-wideband wireless systems," *IEEE Microw. Mag.* **4**(2), 36–47 (2003).
  2. J. P. Yao, F. Zeng, and Q. Wang, "Photonic generation of ultrawideband signals," *J. Lightwave Technol.* **25**(11), 3219–3235 (2007).
  3. Revision of Part 15 of the Commission's Rules Regarding Ultra-Wideband Transmission Systems Federal Communications Commission, Feb. 2002.
  4. S. Pan and J. P. Yao, "A photonic UWB generator reconfigurable for multiple modulation formats," *IEEE Photon. Technol. Lett.* **21**(19), 1381–1383 (2009).
  5. S. Pan and J. P. Yao, "UWB-over-fiber communications: modulation and transmission," *J. Lightwave Technol.* **28**(16), 2445–2455 (2010).
  6. T. T. Pham, X. B. Yu, L. Dittmann, and I. T. Monroy, "Integration of optically generated impulse radio UWB signals into baseband WDM-PON," *IEEE Photon. Technol. Lett.* **23**(8), 474–476 (2011).
  7. Q. Guo, A. V. Tran, and C. J. Chae, "10-Gb/s WDM-PON based on low-bandwidth RSOA using partial response equalization," *IEEE Photon. Technol. Lett.* **23**(20), 1442–1444 (2011).
  8. F. Xiong, W. D. Zhong, and H. Kim, "A broadcast-capable WDM-PON based on polarization-sensitive weak-resonant-cavity Fabry-Perot laser diodes," *J. Lightwave Technol.* **30**(3), 355–361 (2012).
  9. M. Presi, R. Proietti, K. Prince, G. Contestabile, and E. Ciaramella, "A 80 km reach fully passive WDM-PON based on reflective ONUs," *Opt. Express* **16**(23), 19043–19048 (2008).
  10. A. Chowdhury, H. C. Chien, and G. K. Chang, "Centralized, colorless, wavelength reusable 25GHz spaced DWDM-PON with 10 Gb/s DPSK downstream and re-modulated 10Gb/s duobinary upstream for next-generation local access system," in *Proceedings of the 34th European Conference on Optical Communications*, Brussels, Belgium, 2008, Paper We.3. F. 4.
  11. J. Zheng, H. Wang, L. Wang, N. Zhu, J. Liu, and S. Wang, "Implementation of wavelength reusing upstream service based on distributed intensity conversion in ultrawideband-over-fiber system," *Opt. Lett.* **38**(7), 1167–1169 (2013).
  12. U. Gliese, S. Norskov, and T. N. Nielsen, "Chromatic dispersion in fiber-optic microwave and millimeter-wave links," *IEEE Trans. Microw. Theory Tech.* **44**(10), 1716–1724 (1996).
-

## 1. Introduction

For future wireless local-area network (WLAN) and wireless personal-area network (WPAN) applications, it is generally required that the networks have the features such as low-complexity, low-cost, low-power consumption and high-data-rate wireless connectivity [1]. UWB is a promising solution for broadband wireless access and has been extensively investigated recently [2]. The unlicensed use of a spectral band from 3.1 to 10.6 GHz with a power spectral density (PSD) of less than  $-41.3$  dBm/MHz has been approved by the U.S. Federal Communications Commission (FCC) [3]. Due to the constrained PSD of a UWB signal regulated by the FCC, the typical wireless transmission distance is a few meters to tens of meters. To extend the area of coverage, a technique, called UWB over fiber (UWBoF), is thus proposed to distribute UWB over fiber [2], to extend the area of coverage. One key advantage of the UWBoF technology is that broadband optical and electrical signal processing functions can be performed at the central station (CS) with the objective of limiting the use of expensive optical and electronic components in the base stations (BSs) [4–6]. To reduce the overall cost of the system, it is desirable that the optical carrier can be reused from the downstream signal for the upstream transmission. The method based on the signal erasing effect in a gain-saturated reflective semiconductor optical amplifier (RSOA) or in an injection-locked Fabry–Pérot laser diode (FP-LD) could be applied in an UWBoF system theoretically [7–9]. The major limitation of the schemes using an FP-LD or an RSOA is that the extinction ratio or the modulation depth of the downstream signal has to be low, which would limit the system performance. Another solution based on the reuse of a phase-modulated downstream signal has been proposed [10, 11]. As in [10], a differential phase shift keying (DPSK) downstream signal is reused for upstream signal transmission by re-modulating the intensity of the downstream signal. Very recently, a bidirectional UWBoF transmission using a polarization modulator (PolM) is proposed [11]. For the downstream transmission, the regular Gaussian pulse sequence is modulated on an optical carrier at the PolM in the CS and then converted to the UWB pulse via a polarizer. For the upstream transmission, a polarizer is employed to select one polarization direction of the downstream signal, which is phase modulated with the Gaussian pulse. The reused downstream signal is then intensity modulated with the upstream UWB signal and then transmitted to the CS. However, the upstream signal for both schemes in [10] and [11] may be degraded due to the PM-IM conversion resulted from the chromatic dispersion of the transmission link.

In this paper, we propose a new wavelength reuse solution in a bidirectional UWBoF system using a PolM and an electro-absorption modulator (EAM) that is immune to the chromatic dispersion of the upstream link. Since the PolM is a special phase modulator that supports TE and TM modes with opposite modulation indices and the EAM is polarization independent, the PM-IM conversion of the downstream signal due to the chromatic dispersion can be fully eliminated. Bidirectional transmission of a 1.25-Gbps UWB signal over a 17-km single-mode fiber (SMF) is experimentally demonstrated. A power penalty due to the wavelength reuse as low as 0.2 dB is achieved.

## 2. Principle

Figure 1(a) shows the proposed bidirectional UWBoF system using a PolM and an EAM in which the upstream transmission is implemented based on wavelength reuse. In the CS, a light wave from a laser diode (LD) is sent to the PolM via a polarization controller (PC1), which is driven by a UWB downstream signal. The PolM is a special phase modulator based on AlGaAs-GaAs that supports phase modulation along the two principal axes with opposite phase modulation indices. PC1 is employed to orient the polarization direction of the light wave from the LD at an angle of  $45^\circ$  relative to one principle axis of the PolM. The modulated optical wave is transmitted over a SMF to a BS. At the BS, the downstream optical signal is divided into two parts using an optical coupler (OC). One part of the downstream

signal is sent to a polarizer via a second PC (PC2) for PM-IM conversion and then sent to a photodetector (PD1) to generate a UWB downstream signal. The other part of the downstream optical signal is sent to the EAM, which is modulated by an upstream signal. The reused downstream optical signal carrying the upstream data is amplified by an erbium-doped fiber amplifier (EDFA) and then transmitted over another SMF link to the CS. At the CS, the upstream UWB signal is detected by a second PD (PD2).

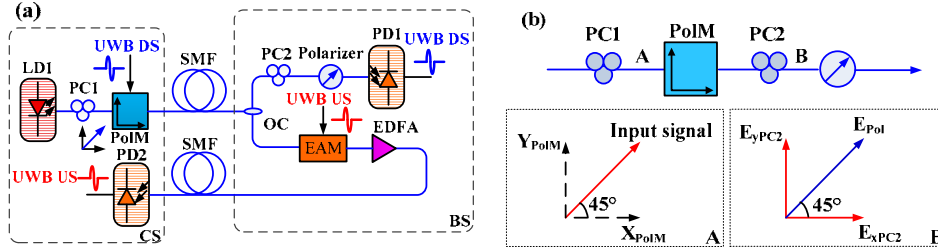

Fig. 1. (a) A bidirectional UWB optical fiber system with wavelength reuse for upstream transmission. (b) Equivalent MZM using a PolM, a PC and a polarizer.

For the downstream link, the PolM is operating in conjunction with PC1, PC2 and the polarizer as an equivalent Mach-Zehnder modulator (MZM) [4]. As it is shown in Fig. 1(b), the polarization direction of the input optical signal is oriented at an angle of  $45^\circ$  relative to one principle axis of the PolM by adjusting PC1. Thus, the light wave is equally projected to the two orthogonal principal axes. The electrical fields of the output optical signal from the PolM along the two orthogonal directions are given by

$$\begin{bmatrix} E_{xPolM} \\ E_{yPolM} \end{bmatrix} = \frac{\sqrt{2}}{2} E_0 \exp(j\omega_0 t) \begin{bmatrix} \exp[j\beta V_{DS}(t)] \\ \exp[-j\beta V_{DS}(t)] \end{bmatrix} \quad (1)$$

where  $E_{xPolM}$  and  $E_{yPolM}$  are the electrical fields at the output of the PolM along the two orthogonal polarization directions,  $E_0$  is the amplitude of the electrical field of the light wave from the LD,  $\omega_0$  is the angular frequency of the light wave,  $\beta$  is the phase modulation index, and  $V_{DS}(t)$  is the electrical field of the downstream UWB signal.

At the BS, the two phase-modulated signals that are orthogonally polarized are sent to a polarizer via PC2. By adjusting PC2, the two orthogonally polarized light waves at the output of PC2 are oriented at an angle of  $45^\circ$  relative to the principal axis of the polarizer, as it is shown in Fig. 1(b). In addition, PC2 also introduces a phase shift of  $\theta$  between the two orthogonally polarized light waves. The electrical fields of the output optical signal from PC2 along the two orthogonal directions are given by

$$\begin{bmatrix} E_{xPC2} \\ E_{yPC2} \end{bmatrix} = \frac{\sqrt{2}}{2} E_0 \exp(j\omega_0 t) \begin{bmatrix} \exp[j\beta V_{DS}(t) + j\theta] \\ \exp[-j\beta V_{DS}(t)] \end{bmatrix} \quad (2)$$

The optical field at the output of the polarizer ( $E_{Pol}$ ) is given by

$$E_{Pol} = \frac{\sqrt{2}}{2} (E_{xPolM} + E_{yPolM}) = E_0 \exp\left[j\left(\omega_0 t + \frac{\theta}{2}\right)\right] \cos\left[\beta V_{DS}(t) + \frac{\theta}{2}\right] \quad (3)$$

The optical wave at the output of the polarizer is sent to PD1 for the photodetection. The photocurrent at the output of the PD1 is given by

$$i_{PD1} = R |E_{Pol}|^2 = \frac{1}{2} R E_0^2 \{1 + \cos[2\beta V_{DS}(t) + \theta]\} \quad (4)$$

where  $i_{PD1}$  is the photocurrent,  $R$  is the responsivity of PD1. Here the phase shift of  $\theta$  is set to be  $\pi/2$  by adjusting the PC2. For small signal modulation, we have  $\sin[2\beta V_{DS}(t)] \approx 2\beta V_{DS}(t)$ , thus the photocurrent in (4) can be rewritten as

$$i_{PD1} \approx \frac{1}{2}RE_0^2 + R\beta E_0^2 V_{DS}(t) \quad (5)$$

From Eq. (5), it can be seen that the downstream UWB signal is recovered by photodetection at PD1.

Basically, the downstream UWB signal is phase-modulated on the downstream optical carrier along the two orthogonal polarization directions. The chromatic dispersion of the fiber link would impact the upstream transmission, since the chromatic dispersion would lead to PM-IM conversion, which would lead to strong interferences between the downstream signal and the upstream signal.

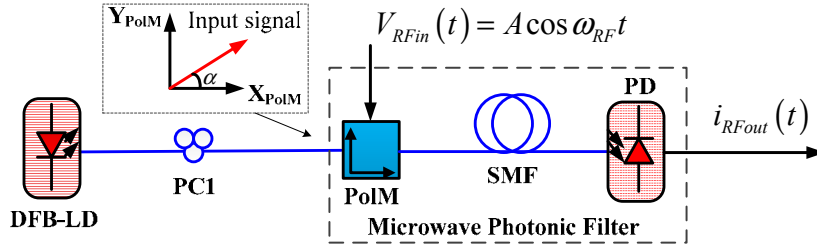

Fig. 2. PM-IM conversion in a SMF link.

Figure 2 shows the PM-IM conversion in a SMF link, corresponding to a microwave photonic filter. Assume that a light wave oriented at an angle of  $\alpha$  to one principle axis (say  $x$  axis) of the PolM is sent to the PolM, to which an RF signal is applied, the optical field at the output of the PolM can be expressed as

$$\begin{aligned} \begin{bmatrix} E_{xPolM} \\ E_{yPolM} \end{bmatrix} &= E_0 \exp(j\omega_0 t) \begin{bmatrix} \cos \alpha \exp[j\beta V_{RFin}(t)] \\ \sin \alpha \exp[-j\beta V_{RFin}(t)] \end{bmatrix} \\ &\approx E_0 \exp(j\omega_0 t) \begin{bmatrix} \cos \alpha \{J_0(\beta A) + J_1(\beta A) [\exp(j\omega_{RF}t) - \exp(-j\omega_{RF}t)]\} \\ \sin \alpha \{J_0(\beta A) + J_1(\beta A) [-\exp(j\omega_{RF}t) + \exp(-j\omega_{RF}t)]\} \end{bmatrix} \end{aligned} \quad (6)$$

where  $V_{RFin}(t)$  is the electrical field of the RF signal applied to the PolM,  $\omega_{RF}$  is the angular frequency of the RF signal,  $A$  is the amplitude of the RF signal,  $J_0$  and  $J_1$  are the zero and first order Bessel functions of the first kind, respectively. Considering the chromatic dispersion, the optical field at the input of the PD ( $E_{PD}$ ) is given by

$$\begin{aligned} E_{PD} &= \begin{bmatrix} E_{PDx} \\ E_{PDy} \end{bmatrix} = E_0 \exp(j\omega_0 t) \\ &\times \begin{bmatrix} \cos \alpha \{J_0(\beta A) + J_1(\beta A) [\exp(j(\omega_{RF}t + \varphi(\omega_{RF}))) - \exp(-j(\omega_{RF}t - \varphi(\omega_{RF})))]\} \\ \sin \alpha \{J_0(\beta A) + J_1(\beta A) [-\exp(j(\omega_{RF}t + \varphi(\omega_{RF})))] + \exp(-j(\omega_{RF}t - \varphi(\omega_{RF})))]\} \end{bmatrix} \end{aligned} \quad (7)$$

where  $\varphi(\omega_{RF})$  is the phase shift between the optical sideband and the optical carrier induced by the chromatic dispersion [12]. Thus, the photocurrent at the output of the PD is given by

$$i_{PD}(t) = k |E_{PD}(t)|^2 \approx i_{DC} + i_{RFout}(t) \quad (8)$$

where

$$i_{DC} = RE_0^2 [J_0^2(\beta A) + 2J_1^2(\beta A)] \quad (9)$$

$$i_{RFout}(t) = -2RE_0^2 \cos 2\alpha J_0(\beta A) J_1(\beta A) \sin(\omega_{RF} t) \sin[\phi(\omega_{RF})]$$

The frequency response of the microwave photonic filter is given

$$H(\omega_{RF}) = \frac{-2kE_0^2 \cos 2\alpha J_0(\beta A) J_1(\beta A) \sin(\phi(\omega_{RF}))}{A} \quad (10)$$

When  $\alpha$  is set to be  $45^\circ$  by adjusting the PC (see Fig. 2), the response of the microwave photonic filter is zero. In this case, the signals due to the PM-IM conversion in the two polarization directions are cancelled. As a result, the chromatic dispersion will induce no impact on the upstream signal transmission. In the system, we propose to use an EAM to modulate an upstream signal on the downstream signal. Since an EAM is polarization independent, the two light waves with orthogonal polarizations from the downstream signal can pass through the EAM and the downstream signals due to the PM-IM conversion are complementary and will be cancelled out at PD2. Thus, the proposed bidirectional UWB transmission with wavelength reuse is immune to the chromatic dispersion.

### 3. Experimental setup

An experiment is performed based on the experimental setup shown in Fig. 3. At the CS, a light wave from LD1 at 1545.25 nm is coupled into the PolM via PC1. The polarization direction of the light wave is oriented at an angle of  $45^\circ$  relative to one principle axis of the PolM by adjusting PC1. The PolM is driven by an UWB signal which is generated by the arbitrary waveform generator (AWG, Tektronix AWG7102). The modulated optical signal is then transmitted to the BS over a 17-km SMF. At the BS, the optical signal is divided into two parts. One part of the optical wave is sent to PD1 via PC2 and the polarizer. In this case, the PolM, in conjunction with PC1, the PC2 and the polarizer, functions as an equivalent MZM. The UWB signal is recovered at PD1, and then sent to a bit error rate tester (BERT) for BER measurement or a digital storage oscilloscope (DSO) for eye diagram measurement.

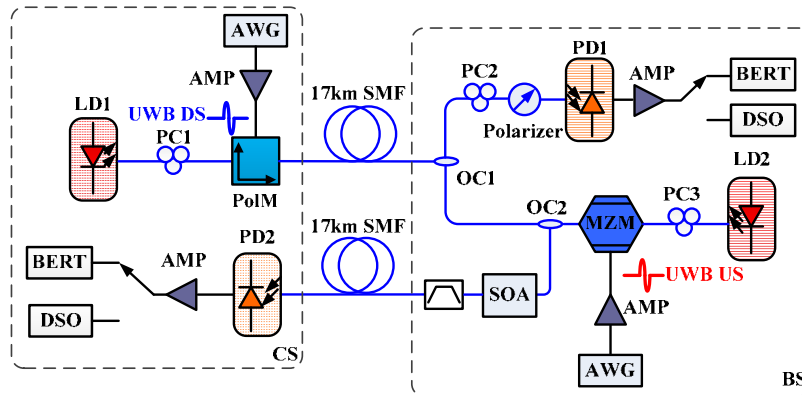

Fig. 3. Experimental setup. LD: laser-diode, PC: polarization controller, PolM: polarization modulator, AWG: arbitrary waveform generator, AMP: electrical amplifier, PD: photodiode, BERT: bit error rate tester, DSO: digital storage oscilloscope, MZM: Mach-Zehnder modulator, SOA: semiconductor optical amplifier

For upstream transmission, since no EAM is available at the time of experiment, an equivalent solution is sought, which is done through cross-gain modulation (XGM) using a SOA to reuse the downstream signal. As can be seen the upstream signal is intensity-modulated on an optical carrier from LD2, which is sent to the SOA. Due to XGM, the

upstream UWB signal is intensity modulated on the downstream signal. Typically the polarization dependence of the EAM and the SOA is both less than 1 dB. The reused downstream signal is sent back to the CS over a 17-km SMF. The upstream signal is detected by PD2 at the CS.

#### 4. Experimental results

Figure 4(a) shows measurement results of the downstream signal. From Fig. 4(a), it can be seen that the receiver sensitivity of the downstream UWB receiver is  $-12$  dBm. The sensitivity here is defined as the optical power required to achieve a BER of  $10^{-9}$ .

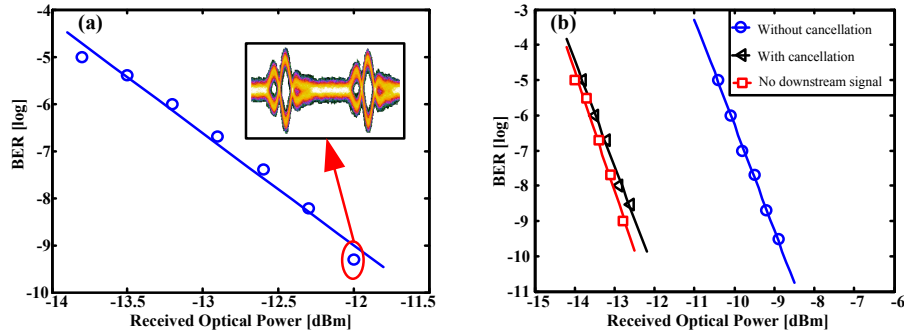

Fig. 4. (a) Measurement results of the downstream signal. (b) BER result of the upstream signal.

Figure 4(b) shows the BER measurement results for the upstream signal. In order to show the improvement of the BER due to the chromatic dispersion cancellation, an experiment without chromatic dispersion cancellation is conducted. To do so, a polarizer is employed to select one polarization direction of the downstream signal for wavelength reuse. In this case, the PolM is equivalent to a phase modulator, thus the impact of the chromatic dispersion on the downstream signal is significant. Comparing the blue line (without cancellation) and red line (the downstream carrier is not modulated by a UWB signal) in Fig. 4(b), it can be seen that the impact of the chromatic dispersion-induced PM-IM conversion can induce 4-dB power penalty. By using the chromatic dispersion cancellation, the power penalty is less than 0.2 dB, as shows as the black line (with cancellation) and red line in Fig. 4(b).

Figure 5 shows the eye diagrams of the upstream signal with or without chromatic dispersion cancellation. It can be seen that the improvement of the chromatic dispersion cancellation is significant.

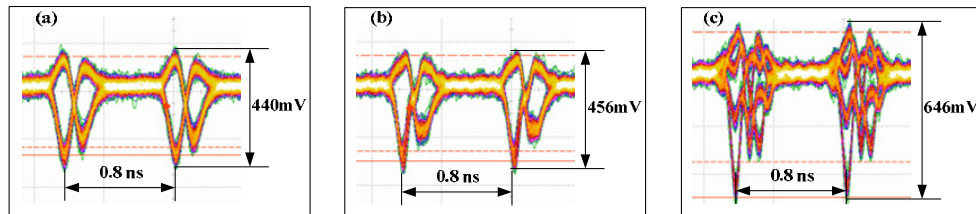

Fig. 5. Eye diagrams of the upstream signal. (a) Without downstream transmission, (b) with chromatic dispersion cancellation, and (c) without chromatic dispersion cancellation.

#### 5. Conclusion

A bidirectional UWBoF system with wavelength reuse for upstream transmission using a PolM and an EAM was proposed and experimentally demonstrated. The key contribution of the technique is that the signals resulted from the PM-IM conversion due to the chromatic dispersion in the upstream link was fully cancelled. A bidirectional point-to-point

transmission of 1.25-Gbps UWB signal over 17-km SMF was experimentally demonstrated. The performance including the eye diagrams and the BERs were measured and evaluated. The power penalty due to the wavelength reuse for upstream transmission was as low as 0.2 dB.

### **Acknowledgments**

This work was supported by the Natural Sciences and Engineering Research Council of Canada (NSERC) through the strategic grant project program.