

2012

Who Are We? Parental Influences on Self-Identities and Self-Esteem of Second Generation Youths in Spain

Alejandro Portes

University of Miami School of Law, aportes@law.miami.edu

Adrienne Celaya

University of Miami

Erik Vickstrom

Princeton University

Rosa Aparicio

Instituto Universitario Ortega y Gasset

Follow this and additional works at: https://repository.law.miami.edu/fac_articles



Part of the [Law Commons](#)

Recommended Citation

Alejandro Portes, Adrienne Celaya, Erik Vickstrom, and Rosa Aparicio, *Who Are We? Parental Influences on Self-Identities and Self-Esteem of Second Generation Youths in Spain*, 70 *RIS* 9 (2012).

This Article is brought to you for free and open access by the Faculty and Deans at University of Miami School of Law Institutional Repository. It has been accepted for inclusion in Articles by an authorized administrator of University of Miami School of Law Institutional Repository. For more information, please contact library@law.miami.edu.

WHO ARE WE?

Parental Influences on Self-identities and Self-esteem of Second Generation Youths in Spain

¿QUIÉNES SOMOS?

Influencia de los padres en la identidad y la auto-estima de los jóvenes de segunda generación en España

ALEJANDRO PORTES cnanfra@princeton.edu

Universities of Princeton and Miami. USA

ADRIENNE CELAYA adriennecelaya@gmail.com

University of Miami. USA

ERIK VICKSTROM evickstr@princeton.edu

Princeton University. USA

ROSA APARICIO rag.migraciones@fog.es

Instituto Universitario Ortega y Gasset. Madrid. Spain

ABSTRACT

We review the literature on determinants of ethnic/national self-identities and self-esteem as a prelude to examining these outcomes among a large, statistically representative sample of second generation adolescents in Madrid and Barcelona. While these psycho-social outcomes are malleable, they still represent important dimensions of immigrant adaptation and can have significant consequences both for individual mobility and collective mobilizations. Current theories are largely based on data from the United States and other Anglo-phone countries. The availability of a new large Spanish survey allows us to test those theories in an entirely different socio-cultural context. In addition to having data on close to seven thousand second generation youths, the study includes a survey of the parents, allowing us to examine directly how parental factors affect adolescent psycho-social outcomes. Theoretical and practical implications of results are discussed.

KEYWORDS

Dissonant acculturation; National-identity; Selective acculturation; Self-esteem; Spain.

RESUMEN

Examinamos la literatura sobre los determinantes de las auto-identificaciones étnicas y nacionales y la auto-estima como paso previo para el análisis de tales resultados en una muestra numerosa y estadísticamente representativa de adolescentes de segunda generación en Madrid y Barcelona. A pesar de que estas variables psico-sociales son altamente maleables en la adolescencia, representan de todos modos dimensiones importantes del proceso de adaptación de los hijos de inmigrantes con consecuencias potencialmente

significativas para su avance individual y movilizaciones colectivas. Las teorías existentes sobre el tema se basan fundamentalmente en estudios conducidos en Estados Unidos y otros países anglófonos. La existencia de una nueva muestra de la segunda generación española nos permite poner a prueba estas teorías en un contexto socio-cultural enteramente distinto. Además de incluir datos sobre cerca de 7.000 jóvenes de segunda generación, el estudio incluye también una muestra representativa de sus padres. Esto nos permite examinar directamente cómo las características de los padres afecta a la adaptación psico-social de sus hijos. Se examinan las implicaciones teóricas y prácticas de los resultados.

PALABRAS CLAVE

Aculturación disonante; Aculturación selectiva; Auto-estima; España; Identidad nacional.

INTRODUCCIÓN*

One of the fundamental aspects of the process of adaptation of immigrants to a host society is their change of identities and the views that they come to hold about their new surroundings. If this is the case among first generation immigrants, how much more so among their offspring —the second generation. Adult immigrants generally have solid identities forged in their countries of origin and tend to acquire only a limited identification with the receiving one. In Glazer's (1954) words, they are *in* the society, but not yet *of* it. By contrast, their children —including those brought at an early age from abroad— are raised in a new environment and mostly are there to stay. The ways in which they come to see themselves, including their positive or negative attitudes to the society that is now theirs, can play a decisive role in their future, including the possibilities of inserting themselves successfully in its hierarchies of status and wealth (Rumbaut 2005; Portes and Hao 1998).

There is a growing literature on the ethnic identities and levels of self-esteem of immigrant youths both in the United States and Western Europe. In part, this surge of interest has been prompted by dramatic events, such as the violent mobilizations in French cities in the fall of 2005 —largely attributed to youths of immigrant origin— and the proliferation of gangs in Los Angeles and other American cities —also created by disaffected second generation adolescents (Schneider 2008; Vigil 2002; Grascia 2004). Less spectacular, but equally important in the long run are the attitudes that this growing population of young citizens come to have of their host country and their own chances of success in it. This paper examines these issues in a new country of immigration —Spain— on the basis of a large and representative sample of second generation youths in its two major

* Data for this analysis comes from the Longitudinal Study of the Second Generation (ILSEG in the Spanish acronym) conducted by a consortium between the Center for Migration and Development at Princeton University and the Institute of Migration Studies of the University of Comillas in Madrid. It was supported by a grant from the Spencer Foundation and by a supplementary grant from the Community of Madrid; responsibility for the contents is exclusively ours.

cities, Madrid and Barcelona. We focus, in particular, on how parental characteristics, impinge on the psycho-social orientations of their youths. The growth of the foreign-born population in Spain has been remarkable in recent years, turning the country into one of the major recipients, in absolute and relative terms, of immigration to major Western European countries (Cachón 2008; Pajares 2009). A surging population of immigrant children and children of immigrants in Spain offers a distinct opportunity to test hypotheses about youth identities and self-esteem developed primarily on the basis of data from the United States and other Anglophone countries. Our question is thus how closely the new second generation in Spain identifies with their country and what attitudes they hold toward it. Further, we wish to know how the character of immigrant families and parents affect these orientations.

LITERATURE REVIEW AND HYPOTHESES

There has been an immense amount of attention to the ethnic identities and self-esteem of immigrant children and children of immigrants in recent years. The research literature has grown by leaps and bounds encompassing the most diverse foreign groups—from Mexicans, Dominicans, and Chinese in the United States (Jimenez 2008; Macias 2004; Louie 2006)—to Caribbeans in the Netherlands (Van Niekerk 2007); Arabs in France (Keaton 2006); and sub-Saharan Africans in Italy (Andall 2002). This level of attention is remarkable since the literature also shows that ethnic/racial self-labels can change rapidly over time and in different social contexts. (Rumbaut and Portes 2001; Altschul, Bybee and Oyserman 2008)). Self-identities and self-esteem are “soft” variables, highly malleable and flexible. Yet, within specific contexts, they have been shown to be associated with an array of important outcomes—from educational and occupational achievement to political militancy (Diehl and Schnell 2006; Feliciano 2009; Portes and MacLeod 1996).

Children of immigrants are confronted with a contest between two cultures, languages, and sets of expectations. The outcomes of this confrontation are not uniform and depend on a number of factors. Specifically, the social context in which these children are raised, the characteristics of their families, and the nature of inter-generational relations can be expected to play a decisive role in their psycho-social profile. As part of their theory of segmented assimilation, Portes and Rumbaut and Portes and Zhou proposed a tripartite typology of inter-generational acculturation outcomes—ranging from *consonant acculturation*, where immigrant parents and children learn and adapt to the new culture and language at a similar pace—to *dissonant acculturation* where children race past their parents and eventually come to reject the parental language and culture in favor of those of the host nation. In between, there is an alternative path—*selective acculturation*—where adaptation to the new cultural environment is accompanied by preservation of the parental language and some key elements of the parents’ culture (Portes and Zhou 1992; Portes and Rumbaut 2001).

This typology and the accompanying model have been frequently used in subsequent research as an interpretive framework for numerous empirical findings concerning adolescent self-identities and self-esteem. Altschul, Bybee and Oyserman (2008) found, for example, that “bridging identities,” akin to selective acculturation, were associated with superior educational and occupational achievements in contrast to the “thin” aschematic identities, reflecting the dissonant path. Bailey (2000) reported that Spanish language preservation was a crucial tool to resist racial stereotyping and discrimination among black second generation Dominicans in the U.S. In her study of Vietnamese-Americans in Orange County and Boston, San-Juan (2005) found that the best path for “becoming American” was “staying Vietnamese”, a pattern reflecting selective acculturation also reported by Zhou and Bankston (1996) in their study of the Vietnamese community of New Orleans.

Other determinants of immigrant identities identified in the research literature include length of time in the country, socio-economic status, attitudes of the native-born population, and the continuity or interruption of migration from the home country. Predictably, length of time in the host country by both parents and children increases the probability of identification with the new society (Arriagada 2007; Diehl and Schnell 2006). A number of studies have also found that education does not increase full identification with the host society, but leads instead to a more nuanced and discerning view that combines old and new identities (Duncan and Trejo 2009; Feliciano 2009; Hughes 2006). The role of family status is not clear, but it is reasonable to assume that higher parental education and occupation facilitate consonant or selective acculturation leading to both easier assimilation and higher self-esteem.

There is general agreement in the literature that discrimination and racial stereotyping by natives slow down the process of identificational assimilation and threaten self-esteem, encouraging reactive and militant identities. Second generation youths consistently exposed to the message that they are not part of the social mainstream for racial or cultural reasons tend to re-affirm the ethnic identities that set them apart as a means to protect their sense of self-worth (Golash-Boza 2006; Louie 2006; Ono 2002; Portes and Rumbaut 2001:ch. 8). The work of Jiménez (2008) also shows that replenishment of the first generation through continuous immigration from the sending country sharpens inter-group boundaries and re-affirms ethnic identities among Mexican-Americans, thereby slowing down assimilation.

The external validity or representativeness of these findings varies greatly. Many studies, especially those among immigrant groups in Europe, are based on small samples of limited generalizability. While some studies combine the analysis of ethnic/racial identities with self-esteem, many others do not, leaving open the question of the relationship between both variables. In addition, parental and family factors, hypothesized to be key determinants of youths’ psycho-social outcomes, are often ascertained from the children themselves opening the possibility of selective recall and endogeneity. Put differently, children’s identity and level of self-esteem may affect how they come to perceive their parents and how they report family characteristics, thereby reversing the hypothesized causal sequence.

This study focuses on self-identities and self-esteem among immigrant-origin youths in Spain. We make use of a unique data set that includes representative samples of Spanish-born and foreign-born children of immigrants in Madrid and Barcelona plus direct interviews with a large sub-sample of their parents. This allows us to measure family characteristics directly, thereby eliminating the threat of endogeneity. From the research literature, we draw a series of determinants that can be classified into objective and subjective factors. The causal direction of the relationship between objective factors and the two social-psychological outcomes is fairly clear, while relationships with other subjective traits are best seen as correlational rather than causal.

Objective factors include parents' and children's age, sex, birthplace, length of residence in the country, family socio-economic status, and knowledge of Spanish. Birthplace indicates Spanish vs. foreign-birth; we also include the parents' nationality because it can affect children's self-identities and self-esteem separate from birthplace. Subjective factors include reported experiences of discrimination and reported relationships with parents indicative of selective vs. dissonant acculturation. They also include parental ambitions, measured as the parents' educational expectations for their children.

The research literature that identifies these determinants is not always clear on the direction of causal effects. Based on past results, a limited set of hypotheses can be advanced as a guide to our analysis. The following ones are, in our view, the most important:

1. Birthplace should significantly influence self-identities, with native-born children being more likely to identify with the host society; length of residence in Spain by both parents and children should also lead to higher identification with the country.
2. Acquisition of Spanish nationality by parents should have the same effects on children's identities.
3. Knowledge of Spanish by parents and children should also increase identification with the country, as well as significantly raise self-esteem.
4. Family socio-economic status will have similar effects, insofar as it promotes consonant or selective acculturation and protects children from events damaging their self-image.
5. Repeated experiences of discrimination lower self-esteem and slow down identification with the host country, leading to more critical attitudes toward it. Reactive identities can emerge as a consequence.
6. Positive inter-generational relations, reflecting consonant or selective acculturation, will heighten self-esteem among children; parental involvement in school activities will have a similar effect.

Other relationships are more ambiguous. For example, it is not clear what effects age or sex have on the two outcomes, how specific national origins influence them, or how attendance at different types of schools (public or private) affects psycho-social orientations. Nor has it been well-established how parental ambition affects self-identities or

self-esteem. These question marks become more salient in a new context of reception where the presence of immigrants and their offspring is a relatively new phenomenon. They represent additional issues to be addressed by the analysis, together with testing the six preceding hypotheses. Before turning to this analysis, we examine briefly the social context receiving immigrant families and where their children are currently growing up.

IMMIGRATION TO SPAIN

Traditionally, Spain has been a country of out-migration, sending millions of migrant workers first to Latin America and, in the post-World War II period, to Northern Europe. Since joining the European Common Market and subsequently the European Union, the country experienced a sustained process of economic growth that brought it into the ranks of the developed world. As a result, labor out-migration not only ceased but reversed itself leading to the return of millions of former emigrants (Cachón 2009; Calavita 2005). Since the early 1990s, Spain has found itself in the unexpected role of recipient of major migration flows, initially from nearby Morocco, and subsequently from Latin American countries, Eastern Europe, and even Asia (Carvajal Gómez 2006).

The foreign-born population has grown by leaps and bounds and, by 2010, it reached 5.7 million, or close to 12.1 per cent of the total (Observatorio Permanente de la Inmigración 2010; Santa-Olalla 2010). The figure is very close to the proportion of the foreign-born in the U.S. population (12.5 percent), despite the much shorter period of Spain-bound migration, scarcely twenty years. Immigration declined sharply in the wake of the economic crisis starting in 2008, a trend common to all of Europe. However, the resident foreign-born have stayed put, consolidating their roots in Spanish soil (Torreblanca 2010; Borasteres 2011).

Inevitably, first generation immigrants have spawned a second generation that currently represents the fastest growing component of Spain's population aged 18 and younger (Aparicio 2006). While immigrant families and their offspring are found throughout the country, the main concentrations are in the metropolitan areas of Madrid and Barcelona, the two largest cities. Not being traditionally a country of immigration, Spain was ill-prepared to guide the incorporation of new immigrants and, especially, their children. The arrival of this young population into the schools and the streets has been accompanied by much uncertainty and considerable anxiety among Spaniards about what the phenomenon portends for their future (Cachón 2009; Aparicio and Tornos 2008). Journalistic articles about the growth of Latin youth gangs or the danger of Islamic fundamentalism among young Moroccans and other second-generation Muslims have proliferated, while the national government and those of the country's autonomous regions (*comunidades autónomas*) have rehearsed numerous policies seeking to integrate immigrant children into the schools and avoid early, but disturbing signs of downward assimilation (Sotelo 2005; Díez Nicolás 2006; Anunión 2010).

So far, however, few empirical studies of children of immigrants in Spain have been conducted and those that exist are based on statistically unrepresentative or exclusively

local samples (Aparicio 2006; Aparicio and Tornos 2008; Gualda 2008). By all counts, this is still a young population, the majority of whom are still children or adolescents. By early adolescence, however, self-identities and attitudes toward the host nation are beginning to take form. Our key concern is what direction they have followed and how they vary by national origin and by the other causal factors discussed previously. A sense of identification or estrangement from the host society has been shown in the past to be an important factor associated with both career aspirations and different adaptation paths (Feliciano and Rumbaut 2005; Zhou *et. al.* 2008; Portes and MacLeod 1996).

Accordingly, a study of the self-identities, and self-esteem of second generation youths in Spain offers a chance of casting light on a so-far unknown population, while simultaneously testing existing theories of psycho-social adaptation in a new social context. As seen previously, propositions about the origins of adolescent self-identities and self-esteem derive primarily from U.S. empirical research, with limited contributions from other countries. Applying them in an altogether different social and cultural environment provides the opportunity to test these theories and to extend and refine them.

METHODOLOGY

The data on which this study is based are the product of a collaborative effort between university-based research centers in the United States and Spain with the aim of interviewing representative samples of second generation youths in their principal areas of concentration. To this end, researchers sought the approval and support of education authorities in Madrid and Barcelona. The research team proceeded to draw random samples of secondary schools in each of the two metropolitan areas, stratified by type of school (public vs. private) and by geographical area. Complete lists of schools were made available for that purpose by the respective education authorities (*consejerías*). This stratified random sample design maintained a constant sampling fraction by school type and by region within each metropolitan area, making the sample statistically representative of the target universes (Kish 1967; Firebaugh 2008).

Within each school, all eligible students were included. "Second generation" was defined as children born in Spain or brought to the country before age 12 with at least one foreign-born parent. By convention, those born in the host country are defined as the second generation "proper," while those brought at an early age from abroad are defined as the "1.5 generation" (Rumbaut 2004). Most immigrant youths in Spain attend public schools, but a significant minority has found its way into state-supported private schools, mostly Catholic-affiliated.¹ One of the subsidiary questions for analysis is whether the

¹ These are known as "concerted" schools. While privately run, they follow state directives in exchange for public support.

self-identities, future plans and self-esteem of these youngsters vary by type of school. Geographically, the sample was also stratified by region to insure that all schools in each metropolitan area were included. Because of the concentration of schools in the respective central cities, a simple random sample would have excluded those in many suburban areas. In total, 180 schools took part in the study; 101 in Madrid and 79 in Barcelona; of these, 111 were public schools and the rest private.

Basic secondary education in Spain is compulsory and its students are, overwhelmingly, in their early adolescent years. These two features are methodologically convenient because they guarantee that a school-drawn sample will be representative of the respective age cohort, since almost all of its members are still in school. The study targeted the

Table 1.
Demographic Characteristics of the Second Generation in Spain, 2008.

Variable	Values	Barcelona	Madrid	Totals
Sex	Male %	54.13	48.54	51.38
	Female %	45.87	51.46	48.62
Age	Mean	13.48	14.36	13.91
	Median	13	14	14
Country of Birth	Spain %	15.94	13.56	14.77
	Abroad %	84.06	86.44	85.23
Years of Spanish Residence (for respondents born abroad)	Mean	6.14	6.78	6.45
	Median	5	6	5
Family Composition	Lives with both natural parents %	65.80	66.87	66.32
Year in Secondary School	1 st	33.59	8.77	21.67
	2 nd	34.73	54.50	44.18
	3 rd	31.68	36.83	34.15
Knowledge of Spanish Speaks:	Little, %	3.69	1.05	2.39
	Some, %	5.68	3.45	4.58
	Well, %	23.86	22.95	23.42
	Perfectly, %	66.77	72.55	69.61
Understands:	Little, %	3.03	0.78	1.93
	Some, %	3.50	2.37	2.95
	Well, %	18.09	19.46	18.76
	Perfectly, %	75.38	77.39	76.36

Source: Longitudinal Study of the Second Generation (ILSEG).

first three years of basic secondary school (ESO in its Spanish acronym)² because they include the population of average age 13-14 that represented the universe of interest. At this age, almost all children are enrolled in school and they are sufficiently mature to be able to fill a simple questionnaire.

The total student sample size is 6,905: 3,375 in Madrid and 3,530 in Barcelona. With a constant sampling fraction, the sample is self-weighting with respect to the total universe and each sampling strata. Table 1 presents its basic demographic characteristics, broken down by each metropolitan area.

Approximately one year after completion of these surveys, the project undertook a new study of parents to complement the data obtained from the children. To this end, letters were sent to the home addresses supplied by students with an attached questionnaire to be completed by their parents. The letter explained the goals of the project and promised an incentive in the form of a money prize to be awarded by random draw among those returning completed questionnaires. Reminders were sent to parents not responding to the original letter. In total, approximately 700 usable questionnaires were obtained, a figure that represented less than half of the target sample for the parental survey—1,750 cases or one-fourth of the children's sample.

The project team then turned to telephone data supplied by students and spent the entire summer and part of the fall of 2010 calling home numbers in Madrid and Barcelona. The team kept a moving tally of completed questionnaires to insure that they would be roughly balanced between both cities and that all major nationalities in the original survey were represented.

In total, data were obtained from 1,843 parents representing 28 percent of the original student survey. The major nationalities in both surveys are identical: In the parental sample, they include Ecuador (28%), Morocco (10.5%), Colombia (7.8%), Peru (6.7%), the Dominican Republic (5.5%), and Romania (5.1%). Among second generation children born abroad, the corresponding figures were: 28.6% (Ecuador); 7.1% (Morocco); 8.4% (Colombia); 6.1% (Peru); 5.2% (Dominican Republic); and 5% (Romania). No other nationality in either sample exceeded 5 percent of the total. This survey provides the necessary data to assess parental effects on second generation identities and self-esteem independently, thus avoiding the endogeneity problem affecting most prior studies.

Preliminary Findings: Descriptive Results

Table 2 presents frequency distributions in both cities of national self-identification, life plans, self-esteem, and related attitudinal variables. A first major finding is that self-identification as "Spanish" encompasses only one-third of the total sample, with the rest identifying primarily with their parents' country of birth. This pattern is the same for youths in Madrid and Barcelona. A large majority in both cities considered their self-identities

² *Educación Secundaria Obligatoria.*

Table 2.
*Self-identities and Related Attitudes of Second
 Generation Youths in Madrid and Barcelona, 2008.*

Variable	Value	Madrid		Barcelona		Total	
		%	N	%	N	%	N
"Do you consider yourself Spanish?"	Yes	27.0	911	30.3	1069	28.7	1980
	No	68.4	2308	63.6	2246	66.0	4554
	Neither/ND ^a	4.6	156	6.1	215	5.4	371
"If not, of what nationality do you consider yourself?" ^b	Bolivian	6.1	136	--	--	5.1	231
	Colombian	7.2	161	10.6	245	8.9	406
	Dominican	--	--	5.6	128	6.1	276
	Ecuadoran	24.9	560	33.2	765	29.1	1325
	Moroccan	7.5	168	5.6	130	6.5	298
	Peruvian	6.1	136	6.1	141	6.1	277
	Romanian	--	--	8.3	192	--	--
"How important is your nationality to you?"	Very important	55.8	1882	54.7	1931	55.2	3813
	Important	29.4	992	29.1	1028	29.3	2020
	Not important	11.9	402	9.2	326	10.5	728
	DK/ND ^c	2.9	99	6.9	245	5.0	344
"In what country would you like to live when you grow up?"	Spain	25.9	874	22.1	781	24.0	1655
	West European	15.2	513	16.4	579	15.8	1092
	North American	23.6	798	24.1	852	23.9	1650
	South American	13.3	449	12.8	451	13.0	900
	Caribbean	3.1	106	1.9	68	2.5	174
	Others	13.9	470	12.8	452	13.4	922
	DK/ND	4.9	165	9.8	347	7.4	512
"There is no better country to live in than Spain"	Strongly Agrees	6.9	232	7.3	257	7.1	489
	Agrees	15.2	512	15.0	531	15.1	1043
	Disagrees	43.1	1455	37.1	1311	40.1	2766
	Strongly Disagrees	28.7	967	26.7	941	27.6	2908
	DK	6.2	209	13.9	490	10.1	699
"People of color have as many opportunities to advance as whites in Spain"	Strongly Agrees	51.3	1732	39.1	1381	45.1	3113
	Agrees	23.4	789	26.1	921	24.8	1710
	Disagrees	12.5	421	13.9	490	13.2	911
	Strongly Disagrees	6.8	231	7.2	253	7.0	484
	DK	6.0	202	13.7	485	9.9	687
"Spaniards feel themselves superior to foreigners"	Strongly Agrees	31.1	1049	26.8	945	28.9	1994
	Agrees	35.2	1188	31.0	1096	33.1	2284
	Disagrees	20.7	698	20.2	712	20.4	1410
	Strongly Disagrees	6.6	224	8.4	296	7.5	520
	DK	6.4	216	13.6	481	10.1	697
Self-esteem ^d							
Mean		3.01		2.93		2.97	

^a ND= No data.

^b Listed nationalities are those representing at least 5 percent of the city samples and the total.

^c DK= Does not know.

^d Scores in Rosenberg's Self-esteem Scale.

Source: Longitudinal Study of the Second Generation (ILSEG).

“important” or “very important”, which adds weight to these findings: they indicate, in essence, that two-thirds of second generation youths who currently live in Spain and are being educated in it do not consider themselves part of Spanish society.

These results are supported by those in the next row of Table 2 that reveal another interesting fact: contrary to what happens in other countries of immigration, a large majority of these youths do not plan to live in Spain as adults. Only one-fourth intend to remain in the country, which is about the same proportion of those who plan to go live in North America. An additional 17 percent plan to move to another West European country. Taken at face value, these results indicate that, having arrived or been born in Spain, the majority of children of immigrants do not consider the country as their final destination, but as a stepping stone for moving elsewhere.

The set of attitudinal questions presented next in Table 2 accords in general with these findings. On the positive side, a large majority of respondents report that there is no

Table 3.
*Second Generation Self-identities and Self-esteem
by Inmigrant Parents' Characteristics¹.*

A. Years of Residence in Spain						
	Low (≤ 6)	Medium (< 10)	High (≥ 10)	Total	F ²	Sig
Percent self-identifying as Spanish	18.3	24.2	43.9	29.8	55.13	.000
Mean self-esteem	2.93	2.94	3.02	2.97	6.33	.01
N	568	568	684	1820		
B. Acquisition of Spanish Nationality						
	No	Yes		Total	F	Sig
Percent self-identifying as Spanish	25.1	39.1		30.5	38.12	.000
Mean self-esteem	2.95	3.00		2.97	5.73	.02
N	1062	663		1725		
C. Socio-economic Status						
	Low (-.78) ³	Medium (-.15)	High (.78)	Total	F	Sig
Percent self-identifying as Spanish	27.7	26.2	39.1	31.0	13.81	.000
Mean self-esteem	2.91	2.98	3.02	2.97	8.3	.001
N	613	613	614	1840		

¹ List-wise deletion of missing data.

² F-test of statistical significance; significance levels in right-most column.

³ Mean PSES score for each category.

color line in Spain, as far as opportunities for advancement are concerned. The generalized perception is that the country is egalitarian, but not particularly attractive in terms of opportunity. Hence, only one-fourth of respondents are in partial or complete agreement with the statement, "There is no better country to live in than Spain." Differences between Madrid and Barcelona in this item, as in all previous ones, are minor indicating that there are no major variations in identities and attitudes between the two cities.

Self-esteem was measured by Rosenberg's Index which has become the standard instrument for tapping this variable in the United States and other countries (Rosenberg 1965; Portes and Rumbaut 2001: Ch. 8). In the Spanish context, a factor analysis of the 10 items composing this index yielded a clear unidimensional structure with all items loading significantly on the first factor which explained almost all common variance. Internal consistency (Cronbach's alpha) is 0.732 in Madrid and 0.694 in Barcelona indicating a high level of reliability. The range of the Index is 1-4 with high scores indicating higher self-esteem levels. As shown in table 2, the mean for the total sample is fairly high, with the Madrid sample having a slight advantage over that from Barcelona.

Table 3 breaks down the two main outcomes of interest —national self-identify and self-esteem by three key parental variables: years of residence in the country, possession of Spanish nationality, and socio-economic status. The latter is a composite index formed by the unit-weighted sum of the responding parent's education and occupational status; those of his/her spouse if any; and family income. All components were standardized and the resulting Parental Status Index (PSES) is also standardized, with mean zero and standard deviation one. Cut off points for the two continuous parental variables were chosen to yield comparable sample sizes in the "low," "medium," and "high" categories.

Parental years of residence in Spain has a decisive effect on national self-identities, with offspring of long-term residents having a much higher probability of a Spanish identification. The same youths also display significantly higher levels of self-esteem. Acquisition of the country's nationality has parallel effects. Those of parental status reinforce the same trends, with higher-status parents encouraging a stronger identification with Spain and promoting higher self-esteem. These preliminary tabulations usher the way to multivariate analyses of the same outcomes, where the effects of these and other parental characteristics are assessed relative to those of the children themselves.

MULTIVARIATE RESULTS

a. National Self-identities

We examine first determinants of national self-identity, coded as a dichotomy (Spanish =1; Others = 0). We analyze its hypothesized determinants using binomial logistic regression. Logit coefficients express the incremental effect of each exogenous variable on the logarithm of the odds ratio corresponding to the endogenous variable. To facilitate their

interpretations, we exponentiate all significant coefficients. Exponentials indicate the net increase/decrease in the odds that the endogenous variable will take a value of 1 for each unit increase of the predictor. Coefficients greater than one indicate a net increase relative to the sample mean; those lower than one indicate a decrease (Petersen 1985).

We use list-wise deletion as the most conservative method of handling missing data. Various imputation routines simply inflate the size of the sample yielding substantively similar results, but less rigorous tests of significance (Firebaugh 2008). Throughout the analysis, we also employ robust standard errors to adjust for the school-clustered character of the original children sample. As predictors, following the previous theoretical discussion, we include an array of parental variables measured directly in the parents' survey, plus characteristics of the youths themselves. We employ a step-wise procedure in which hypothesized parental factors plus control variables are introduced first, followed by parental national origins. In the final step, children's hypothesized and control characteristics enter the equation.

Parental predictors include socio-economic status (PSES), length of residence in Spain, current nationality, marital status, educational expectations for the child, and knowledge of Spanish. The latter is measured by an index formed by the sum of self-reported ability to understand, speak, read and write in Spanish. The research literature in linguistics has consistently found self-reported language ability to be a reliable indicator (Fishman 1981; Lopez 1982; Hakuta 1986). The Parental Knowledge of Spanish Index (PKSI) yields an alpha coefficient of .89 indicating a high level of internal consistency. We also include parental age and sex as control variables.

Length of Spanish residence is measured in years. Marital status ("married") and current nationality ("Spain") are dummy variables, coded in agreement with their labels. We include the nationality of the responding parent and his/her spouse, if any. Educational expectations for the child are coded along a four-point scale—from "secondary or less" to "post-graduate degree". Parental school involvement (PSII) is also an index constructed as the unit-weighted sum of three items indicating participation in various school activities and willingness of the parents to discuss school matters with teachers and their children themselves. Among the sixty-three nationalities identified in the children survey, fifteen numbered more than 25 cases in the parental sample. These are identified by individual dummy variables, with the rest of the sample serving as the reference category. To avoid clutter, only significant nationality effects are presented.

Children's hypothesized determinants include length of Spanish residence, current nationality, knowledge of Spanish, inter-generational relations, and past experiences of discrimination. We also include age, sex, city of residence, and type of school as control variables. Length of residence is measured in years.³ Current nationality is a dummy variable (Spain = 1; Others = 0); and knowledge of Spanish is measured by an index identical to that already described for parents (KSI).

³ For children born in Spain, this variable is equivalent to their chronological age.

Inter-generational relations is also an index (INTGEN) composed of the sum of four dichotomous items indicating whether or not the child feels embarrassed by his/her parents' behavior and whether parents and children see the world in similar ways. Higher scores in this Index reflect a more positive relationship with parents indicative of consonant or selective acculturation; lower scores indicate the likelihood of dissonant acculturation. Experiences of discrimination, another hypothesized determinant, is measured by a single item based on the reported frequency with which the child has felt rejected by others. Among control variables, city of residence (Madrid = 1) and type of school (Private = 1) are also dummy variables. The vast majority of private schools in Spain are run by Catholic orders or are Catholic affiliated.⁴ Descriptive statistics for all variables in the analysis are presented in the Appendix.

A look at the first columns of Table 4 shows that the strongest parental predictor of Spanish identification is the family's length of residence in the country, followed by its socio-economic status. Each additional year of residence leads to a 2-to-1 increase in the odds of a Spanish self-identity; each unit increase in the PSES index raises it by 1.45 to 1. Acquisition of the Spanish nationality, especially by the respondent's spouse, also has a strong positive effect. Counter intuitively, parental knowledge of Spanish *reduces* identification with the country. Reasons for this unexpected result become apparent when we turn to the second set of regressions in the table: with other parental characteristics controlled, children of Latin American origin have a consistently significant lower probability of identification with the country. These include Bolivians, Colombians, Ecuadorens, Peruvians, and Dominicans. All these nationalities are Spanish-speaking. Once they are included in the equation, the strong negative effect of PKS1 is significantly reduced.

Reasons why children whose cultural roots are close to Spain are less likely to identify with the country are not immediately apparent. A plausible hypotheses is that most of these youths are recent arrivals and, hence, insufficiently acculturated. A look at the final set of regressions in Table 4 shows, however, that this hypothesis is untenable: with country of birth and length of Spanish residence controlled, the same nationalities continue to be significantly less likely to identify with the country. Not all Latin nationalities produce the same effect, however. It is absent, for example, among children of Argentina, Chilean, and Venezuelan parents. Thus, it is primarily among mestizo immigrants from the Andean highlands and mostly mulatto and black immigrants from the Dominican Republic that this effect is most apparent, suggesting that it has its roots in racial discrimination. Yet, the inclusion of past experiences of discrimination in the last equation does not entirely eliminate these national effects. For the most part, children rejecting Spanish self-identification choose to identify with their parents' country of origin.

Among children's own characteristics, place of birth has the strongest effect, followed

⁴ A minority of private schools are not "concerted". They are high-tuition institutions attended mostly by children of elite families. Few children of immigrants are found among them and, for this reason, they were excluded from the sample.

Table 4.
Determinants of Children of Immigrants' Self-Identities in Spain, 2010

Predictors	Outcome: Identifies him/herself as Spanish									
	I			II			III			
	Coeff. ¹	Wald ²	Exp B ³	Coeff.	Wald	Exp B	Coeff.	Wald	Exp B	Exp B
Parent										
Age	.019	1.85#	1.02	.012	1.20	---	.005	0.50	---	---
Female	-.045	-0.34	---	.058	0.41	---	.020	0.13	---	---
Years of Spanish Residence	.689	8.13***	1.99	.574	6.36***	1.77	.193	1.66#	1.21	1.21
Spanish Nationality	.140	1.03	---	.357	2.48*	1.43	.349	2.22*	1.42	1.42
Married	.033	0.23	---	-.151	-1.01	---	.028	0.18	---	---
Spouse's Spanish Nat.	.425	3.01**	1.53	.511	3.45**	1.67	.243	1.44	---	---
Knowledge of Spanish (PKSI)	-.303	-4.32***	.739	-.151	-1.82#	-.860	-.223	-2.44*	-.80	-.80
Socio-economic Status (PSES)	.371	4.31***	1.45	.225	2.40*	1.25	.186	1.82#	1.20	1.20
Educational Expectations	.017	0.22	---	.031	0.40	---	-.042	-0.49	---	---
School Involvement (PSII)	.051	0.49	---	.138	1.23	---	.105	0.84	---	---
National Origin ⁴										
Bolivian				-1.469	-3.35**	.230	-1.182	-2.53*	.31	.31
Colombian				-.886	-3.35**	.421	-.535	-1.92#	.58	.58
Ecuadorian				-1.153	-5.77***	.316	-.807	-3.57***	.45	.45
Peruvian				-.728	-2.80**	.483	-.522	-1.85#	.59	.59
Dominican				-1.379	-4.42***	.252	-1.154	-3.08**	.31	.31

Table 4.
(Cont.)

Predictors	Outcome: Identifies him/herself as Spanish					
	I		II		III	
	Coef. ¹	Wald ²	Exp B ³	Coef.	Wald	Exp B
Child						
Age				-.209	-3.17**	.81
Female				-.218	-1.63	---
City of Residence (Madrid)				.133	0.84	---
Born in Spain				.980	3.58***	2.66
Years of Spanish Residence				.109	3.57***	1.12
Knowledge of Spanish (KSI)				-.144	-0.99	---
Experiences of Discrimination				-.110	-0.93	---
Inter-generational Relations (Int Gen)				.102	0.94	---
Private School				.356	2.15*	1.43
Constant		-2.825			-2.435	1.286
N		1607			1607	1471
Chi Square		148.44***			211.97***	241.20***
Nagelkerke R ²		.091			.139	.193

¹ Binary logistic regression coefficients.

² Significance test.

³ Net odd ratios; significant effects only.

⁴ Dummy variables for fifteen parental nationalities were included in the second and third steps. To avoid clutter, only significant effects are reported.

p < .10

* p < .05

** p < .01

*** p < .001

by years of Spanish residence. Children born in Spain are almost three-to-one more likely to identify themselves with the country; each additional year of residence raises the odds of this outcome by .12. These results support the original hypotheses, indicating that the process of acculturation is following its normal course. The second generation “proper” (i.e. those born in Spain) are much more likely to see themselves as Spanish and additional years of residence, by both parents and children, produce the same outcome. Among control variables, age and attendance to private schools also have significant, albeit opposite effects. Private schooling accelerates the process of identificational assimilation, while age retards it. The latter effect is directly attributable to the greater probability of foreign birth among older respondents; they are more likely to have been brought to the country in childhood and, hence, be less exposed to the acculturative process than the native-born.

We conclude that immigrant parents do affect the self-identity of their children, although not always in the expected ways. Predictably, acquisition of the Spanish nationality and years of residence accelerate identificational assimilation, but knowledge of Spanish and closer cultural affinity with the country retards it. Since this is not the case among all Latin American nationalities and the effects do not disappear after controlling for socio-economic status, birthplace, or past experiences of discrimination, we must tentatively attribute them to distinct cultural characteristics among certain Andean and Caribbean groups. Their origins and nature are not self-evident at this point.

b. Self-esteem

Table 5 presents the corresponding results for self-esteem. Since the dependent variable is a continuous index, we shift the estimation procedure to ordinary least squares regression. A first observation is that the pattern of effects is quite different from that just observed. The first model including parental predictors supports several of the initial hypotheses concerning the positive effects of family socio-economic status and parental school involvement. A unit increase in each of these indices raises self-esteem by a net .04 points in the 1-to-4 Rosenberg scale. Years of residence plays a similar role but the strongest, and unpredicted, effect belongs to parental educational expectations: each additional step in the expectations scale raises children’s esteem by a net .07 points. Other analyses of these data (not shown) indicate that parental ambition, as reflected in these expectations, is also a strong predictor of children’s own aspirations. Thus, ambition in the second generation goes together with a positive self-image, both being promoted by parents’ own goals for their offspring.

Inclusion of national origins in the second model in Table 5 produces additional unanticipated effects. First, parental school involvement ceases to be a significant predictor. The influence of family SES and parental expectations remain about equally strong. The array of reliable nationality effects on self-esteem is entirely different from those found for self-identity. No single Latin nationality has an effect on this outcome. Instead, it is replaced by the positive influence of Bulgarian origin and the negative ones, of Chinese,

Table 5.
Determinants of Self Esteem among Second Generation Youths in Spain, 2010

Predictors	Self-esteem Scale (1-4)					
	I		II		III	
	Coeff. ¹	t ²	Coeff.	t	Coeff.	t
Parent						
Age	.003	1.9#	.003	1.4	.001	0.9
Female	.003	-0.1	-.010	-0.4	-.017	-0.7
Years of Spanish Residence	.041	2.6**	.043	2.5*	.010	0.5
Spanish Nationality	-.016	-0.6	-.005	-0.2	-.007	-0.3
Married	.008	0.3	.007	0.3	.004	0.2
Spouse's Spanish Nat.	.027	1.0	.024	0.8	.011	0.4
Knowledge of Spanish (PKSI)	.007	0.5	.005	0.3	.005	0.4
Socio-economic Status (PSES)	.041	2.5*	.040	2.3*	.025	1.5
Educational Expectations	.067	4.8***	.063	4.5***	.040	3.0**
School Involvement (PSII)	.038	2.0*	.022	1.1	-.009	-0.5
National Origin³						
Bulgarian			.164	1.9#	.267	3.3***
Chinese			-.174	-2.5*	-.023	-0.3
Filipino			-.183	-2.8**	-.087	-1.4
Pakistani			-.267	-2.9**	-.157	-1.7#
Child						
Age					.013	1.4
Female					-.062	-2.9**
City of Residence (Madrid)					-.006	-0.3
Born in Spain					.112	2.5*
Years of Spanish Residence					-.001	-0.2
Knowledge of Spanish (KSI)					.143	6.5***
Experiences of Discrimination					-.106	-5.4***
Inter-generational Relations (Int Gen)					.173	9.6***
Private School					-.022	-0.8
Constant		2.438		2.578		1.758
N		1577		1576		1496
R		7.87***		4.93***		12.43***
R ²		.047		.069		.213

¹ Unstandardized ordinary least squares coefficients with robust standard errors.

² T-ratios of statistical significance.

³ Dummy variables for fifteen parental nationalities were included in the second and third steps. Only significant nationality effects are reported.

p < .10; *p < .05; **p < .01; ***p < .001

Filipino, and Pakistani ancestry. *None* of these nationalities affected, positively or negatively, the probability of Spanish self-identification.

The addition of children's own characteristics eliminates almost all parental effects with the notable exception of educational expectations. Ambitious parents continue to significantly strengthen their children's self-image, regardless of other factors. For reasons not clear at present, children of Bulgarian immigrants continue to display higher self-esteem after controlling for other predictors, this being the only significant nationality effect. The other reliable coefficients in this third model tell an important story that agrees, in all its essentials, with the original hypotheses: Girls exhibit much lower levels of self-esteem than boys, replicating a finding consistently reported by research in the U.S. and elsewhere. The second generation "proper" —those born in Spain— display, on the contrary, significantly higher self-esteem than their 1.5 generation counterparts.

These are predictable results. However, the strongest effects in the model are associated with a trio of theoretically and practically significant variables. Greater command of Spanish raises children's self-image; the corresponding coefficient reaches almost seven times its standard error. Almost as important is the effect of past experiences of discrimination which, as expected, leads to lower self-esteem. The strongest influence, however, corresponds to Inter-generational Relations. Good rapport with parents, reflective of consonant or selective acculturation, raises children's self-image by a net .17 points per unit increase in the Int Gen Index. If this effect is combined with that of parental expectations, we conclude that ambitious parents, who have managed to instill in their young a strong identification with their own culture produce the strongest adolescent self-images, counterbalancing the potentially negative effects of external discrimination. The influence of this set of predictors raises explained variance in self-esteem to a sizable 21 percent or 16 percent ahead of the initial model.

A Structural Model of Psycho-social Adaptation

Having examined separately self-identities and self-esteem, we now seek to integrate results into a single model that provides a unified theoretical statement of our findings. For this purpose, we make use of structural equations models (SEM) estimated through the AMOS routine. All theory implies simplification and our case is no exception. Hence, we do not aim to include in the model all individual findings discussed previously, but only the most significant from a theoretical or practical viewpoint. This model seeks to capture determinants of two outcomes: Self-identities, defined as a binary measure with Spanish coded 1, and all others 0; and Self-esteem, defined as scores in Rosenberg's index. The model is presented in Figure 1.

As exogenous variables, the model includes parental socio-economic status, parental knowledge of Spanish, and years of Spanish residence. It also includes the child's age, gender, and birthplace. Birthplace is a dichotomy with the Spanish-born coded 1 and those born abroad, 0. National origins are also included as a dichotomy, reflecting the significant negative influence on Spanish identity of certain Caribbean and Andean

nationalities. This variable is coded 1 if the parents were born in the Dominican Republic, Bolivia, Colombia, or Ecuador or Peru and 0 otherwise.

The causal direction of this array of exogenous variables on the two dependent variables is unambiguous since it is implausible that adolescent self-identities or self-esteem could determine parental birthplace, family status, or national origin. As intervening variables, mainly affecting self-esteem, the model includes parental educational expectations, the child's knowledge of Spanish (KSI), the index of inter-generational relations (INTGEN), and past experiences of discrimination. While it is possible that levels of self-esteem can affect these variables, theoretical logic and the weight of past research evidence indicate that causal directionality runs in the opposite direction. It is more plausible, for example, that parent-child relations and parental ambition affect adolescent self-esteem than the other way around. The same is the case for knowledge of the host country language. For this reason, the model in Figure 1 is fully recursive.

The strongest effect on children's national identity is their birthplace whose effect in the AMOS estimation exceeds 36 times its standard error. The next strongest effect is the child's age and it is negative, reflecting the greater probability of older youths being born abroad and, hence, remaining attached to their native country. These two effects tell, in essence, the same story about the decisive importance of country of birth on self-identities. Parental characteristics also retain significant effects. Both, longer residence in Spain and higher socio-economic status support a pre-Spanish orientation. The opposite is the case for Caribbean/Andean origins that discourages this identity, even after controlling for other predictors. This effect reduces Spanish self-identification by about 10 percent in the AMOS estimate.

Self-esteem is determined by an entirely different array of predictors. Indeed, the two dependent variables do not have a single direct determinant in common and their residual correlation is minimal. The strongest predictor of self-esteem is inter-generational relations, whose coefficient exceeds 26 times its standard error. Each point increase in the INTGEN index leads to a corresponding net increase of .19 in self-esteem. Knowledge of Spanish (KSI) also has a strong positive influence, while past experiences of discrimination significantly reduces self-esteem. Both effects again reinforce the original theoretical expectations concerning the effect of language fluency and relationships with members of the host society on adolescent self-images. Gender (female) has the expected negative effect, while parental ambition retains a significant positive influence, being the only parental variable to do so.

Overall, the model does a fair job in accounting for the main causal trends in the data, as indicated by the residual effects of predictors of one of the two dependent variables on the other. These effects (not shown) are, without exception, not significantly different from zero. Explained variance is sizable for both outcomes: the R^2 coefficients for national self-identity and self-esteem are both .200. Explained variance in the four intervening variables is much lower, but this is less relevant to the theoretical purposes of the model, and is compensated by its overall parsimony: it employs only 52 of 104 distinct sample moments, leaving 52 available degrees of freedom.

Figure 1.
A Structural Model of Psycho-Social Outcomes in the Second Generation¹

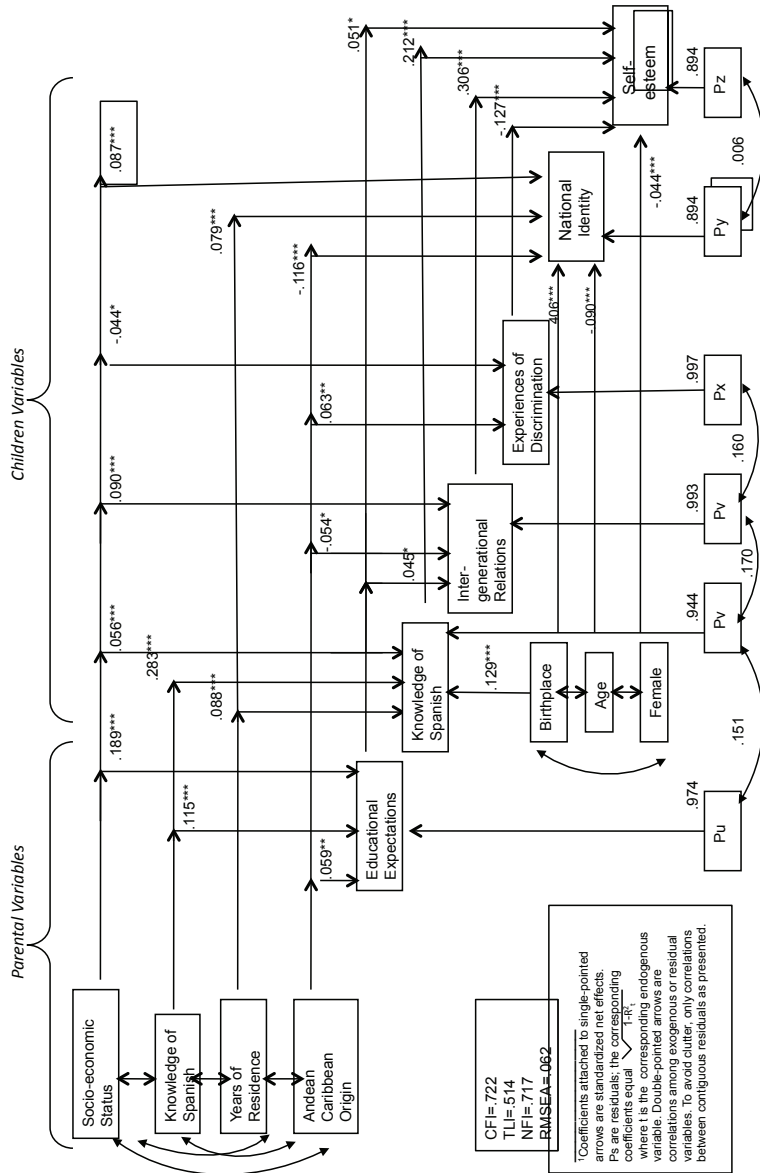

For this reason, diagnostics, although not perfect, are within an acceptable range: the CFI 1 index is .722 as compared to 1.000 for the fully saturated model; so does the NFI (.717). The TLI in the AMOS estimation is only .514; but the widely used Steiger's root mean square error of approximation (RMSEA), a measure that takes into account the model's parsimony, approximates the basic criterion of 0.05 (Maruyama 1998). The model allows for correlations of residuals among endogenous variables. As noted, the correlation between the two outcomes is close to zero, while those between the three intervening variables are higher but still modest.

CONCLUSION

Mass immigration in the last decades of the twentieth century and the initial one of the twenty-first has had significant effects on receiving societies, modifying their demographics, the composition of their labor force, and the look and "feel" of their cities. One of the most important long-term consequences is the emergence of a second generation entitled to citizenship in host nations and comprising a growing percentage of their young population. This second generation poses a serious challenge for receiving societies and governments that must seek to integrate and educate its members to become law-abiding and productive citizens. For the most part, research and theorizing on the present and future of children of immigrants have been conducted in the United States, although there is a growing literature on the topic in Western Europe.

In this paper, we seek to contribute to this emerging comparative literature by drawing on a large and statistically representative sample of second generation youths in the two largest Spanish cities, Madrid and Barcelona. The survey corresponds to the first phase of a longitudinal study that intends to follow this population over time and into early adulthood. Accordingly, the survey targeted an adolescent population of average age 14. At this point, adaptation outcomes are not final, comprising instead a set of academic and social psychological variables. From these, we selected national self-identity, attitudes toward the host nation, and self-esteem for analysis.

Self-identities are significant not only to individuals themselves but, under certain circumstances, to the host society. Resilient foreign identities can provide a basis for solidarity, resistance and, on occasion, massive protest mobilizations—as exemplified by the revolts of immigrant youths in French cities in 2005 (Schneider 2008). Conversely, identification with the host society represents a definite sign of integration and establishes the psychological basis for pursuing upward mobility within it. On its part, self-esteem has been consistently associated with positive academic outcomes and is influenced, in turn, by the quality of relations with parents and by past experiences of acceptance or rejection in the host society.

Our analysis reveals an initially anomalous result: the majority of children of immigrants in Spain neither identify with the country nor intend to live there as adults. This finding is mostly accounted for by the sample's composition, since the vast majority of

it are members of the 1.5 generation —born abroad and brought to Spain at an early age. Once this factor is taken into account, the distribution changes markedly. Even then, however, more than half of the native-born do not intend to live in the country as adults and only a third believe that Spain is the best country to live in. These results indicate that, along with strong identification with the country as “theirs,” most native-born children of immigrants tend to hold a rather dim view of their future opportunities in it. The relatively recent entry of Spain into the ranks of the developed world and its poorer labor market opportunities, relative to richer Western European countries and the United States, may arguably be a reason for these perceptions (Cachón 2009).

In contrast with much of the existing literature, our analysis does not rely on children’s reports about their parents’ characteristics but measures these traits directly. This approach eliminates the threat of endogeneity, likely when child-reported family variables are presented as causal predictors of adolescent outcomes. Overall, the analysis shows that independently-measured parental variables have the hypothesized effects, although they are mostly “filtered” through children’s own characteristics. This is especially the case for self-esteem where the sole parental significant effect, net of youths’ own traits, was not originally hypothesized: parental ambition mediates the effects of family socio-economic status and length of Spanish host country residence, leading, in turn, to more positive adolescent self-images.

The multivariate analysis demonstrates that parental length of residence in the country and, especially, being native-born, are decisive determinants of Spanish identification. This is solid evidence allaying fears that the second generation is not integrating properly. Resistance to identification with the country is higher among older respondents, almost all of whom are foreign-born and among youths of Andean and Caribbean origins. The latter effect could be plausibly attributed to past experiences of discrimination, although results of our analysis do not provide much support for this explanation: introduction of a direct measure of experiences of discrimination does not eliminate the negative effect of Andean/Caribbean origins. Nevertheless, in relative terms, this effect is much less important than that of birthplace. A separate analysis (not shown) indicates that, with the sample restricted to the native-born, neither age nor national origins retain a significant influence on national identities.⁵

Self-esteem and national self-identity are not correlated. This result is plausibly due to the adjustment of national and ethnic self-identification in order to protect self-esteem. Still, despite whatever adjustments in self-identities are made, past experiences of discrimination significantly lower self-images. Overall, it is clear that determinants of this psycho-social outcome are primarily *relational*: good relations with parents, coupled with parental ambition, decisively strengthen young people’s self-images. Capacity to converse fluently in the language of the land works in the same direction, while confrontations with the native-born and experiences of rejection have the opposite effect.

⁵ Results are available from the authors upon request.

The adolescent outcomes that we have examined will surely change over time. Nevertheless, the current profile is likely to affect the evolution of the process of second generation adaptation in future years. Lower self-esteem brought about by experiences of discrimination coupled with resistance to identify with the host society can easily lead to a lowering of youths' aspirations, premature school abandonment, and the rise of reactive ethnic identities. Conversely, a strong self-image brought about by good relations with parents and linguistic progress will lead in the opposite direction, strengthening second generation youths' future aspirations and achievement.

While birthplace, national origins, or inter-generational relations are normally outside of the realm of public intervention, policies to facilitate Spanish language acquisition by both parents and children and to protect them from blatant episodes of discrimination can be undertaken to promote positive psycho-social adaptation, in terms of both self-identities and self-esteem. Such outcomes should lead, in turn, to sustained educational and occupational advancement, thereby by-passing the threat of downward assimilation among the new Spaniards.

REFERENCES

- Aguilar San Juan, K. 2005. "Staying Vietnamese: Community and Place in Orange County and Boston." *City and Community* 4:37-65.
- Altschul, I., D. Oyserman, and D. Bybee. 2008. "Racial-Ethnic Self-Schemas and Segmented Assimilation: Identity and the Academic Achievement of Hispanic Youth." *Social Psychology Quarterly* 71:302-320.
- Andall, J. 2002. "Second-generation attitude? African-Italians in Milan." *Journal of Ethnic and Migration Studies* 28:389-407.
- Aparicio, R. 2006. *Hijos de inmigrantes se hacen adultos*. Madrid: Observatorio Permanente de la Inmigración, Ministerio de Trabajo e Inmigración.
- Aparicio, R. and A. Tornos. 2008. *Aproximación al estudio de las bandas latinas en Madrid*. Madrid: Ministerio de Trabajo e Inmigración.
- Arriagada, P. A. 2007. "In search of an identity in young adulthood: Ethnic self-identification among children of immigrants." Ohio State University.
- Aunión, J. 2010. "El abandono escolar solo existe entre extranjeros". *El País*, July 14, pp. 28-29.
- Bailey, B. 2000. "Language and Negotiation of Ethnic/Racial Identity Among Dominican Americans." *Language in Society* 29:555-582.
- Bailey, B. 2001. "Dominican-American Ethnic/Racial Identities and United States Social Categories." *International Migration Review* 35:677-708.

- Barbulo, T. 2009. "La crisis económica frena en seco la llegada de inmigrantes". *El País* April 4, p.12.
- Borasteros, D. 2011. "Baja el numero de inmigrantes por las nacionalizaciones de los ecuatorianos." *El País*. April 13, p.6.
- Cachón, L. 2009. *La España inmigrante*. Barcelona: Anthropos.
- Calavita, K. 2005. *Immigrants at the Margins: Law, Race, and Exclusion in Southern Europe*. Cambridge, UK: Cambridge University Press.
- Carvajal Gómez, M. I. 2006. "Evolución de las cifras de extranjeros con tarjeta de autorización en vigor." Pp. 85-112 in *Veinte años de inmigración en España: Perspectivas jurídicas*, edited by E. Aja and J. Arango. Barcelona: Fundación CIDOB.
- Diehl, C., and R. Schnell. 2006. "'Reactive Ethnicity' or 'Assimilation'? Statements, Arguments, and First Empirical Evidence for Labor Migrants in Germany." *International Migration Review* 40:786-816.
- Díez Nicolás, J. 2006. *Las dos caras de la inmigración*. Madrid: Observatorio Permanente de la Inmigración, Ministerio de Trabajo e Inmigración.
- Duncan, B., and Stephen J. Trejo. n.d. "Ancestry Versus Ethnicity: The Complexity and Selectivity of Mexican Identification in the United States." *SSRN eLibrary*. http://papers.ssrn.com/sol3/papers.cfm?abstract_id=1150721 (Accessed October 15, 2009).
- Farver, Jo A. M., S. K. Narang and B. R. Bhadha. 2002. "East meets West: Ethnic identity, acculturation, and conflict in Asian Indian families." *Journal of Family Psychology* 16:338-350.
- Feliciano, C. 2009. "Education and Ethnic Identity Formation among Children of Latin American and Caribbean Immigrants." *Sociological Perspectives* 52:135-158.
- Feliciano, C. and R. Rumbaut. 2005. "Gendered Paths: Educational and Occupational Expectations and Outcomes Among Adult Children of Immigrants." *Ethnic and Racial Studies* 28 (November): 1087-1118.
- Firebaugh, G. 2008. *Seven Rules for Social Research*. Princeton, NJ: Princeton University Press.
- Fishman, J. A. 1981. "Language Maintenance." Pp. 629-38 in *Harvard Encyclopedia of American Ethnic Groups*, edited by Stephan Thernstrom. Cambridge, MA: Harvard University Press.
- Glazer, N. 1954. "Ethnic Groups in America." Pp. 158-73 in *Freedom and Control in Modern Society*, edited by T. A. M. Berger, and C. Page. New York: Van Nostrand.
- Golash-Boza, T. 2006. "Dropping the Hyphen? Becoming Latino(a)-American through Racialized Assimilation." *Social Forces* 85:27-55.
- Grascia, A. M. 2004. "Gang Violence: Mara Salvatrucha-Forever Salvador." *Journal of Gang Research* 11 (2):29-36.
- Gualda, E. 2009. "Aspiraciones y expectativas educativas y laborales de jóvenes inmigrantes e hijos de inmigrantes escolarizados." Paper presented at the VI Congress of Migration to Spain, La Coruña, Galicia (September).

- Hakuta, K. 1986. *Mirror of Language: The Debate on Bilingualism*. New York: Basic Books.
- Hughes, D. *et al.* 2006. "Parents' ethnic-racial socialization practices: A review of research and directions for future study." *Developmental Psychology* 42:747-770.
- Jiménez, T. R. 2008. "Mexican Immigrant Replenishment and the Continuing Significance of Ethnicity and Race." *American Journal of Sociology* 113:1527-1567.
- Kish, L. 1967. *Survey Sampling*. New York: Wiley.
- Lieberson, S. 1980. *A Piece of the Pie, Blacks and White Immigrants Since 1880*. Berkeley: University of California Press.
- López, D. E. 1982. *Language Maintenance and Shift in the United States Today: The Basic Patterns and Their Social Implications. Volume 1-4*. Los Alamitos, CA: National Center for Bilingual Research.
- Louie, V. 2006. "Growing Up Ethnic in Transnational Worlds: Identities Among Second-Generation Chinese and Dominicans." *Identities: Global Studies in Power and Culture* 13:363-394.
- Macias, T. 2004. "Imaginándose Mexicano: The Symbolic Context of Mexican American Ethnicity Beyond the Second Generation." *Qualitative Sociology* 27:299-315.
- Maruyama, G. 1998. *Basics of Structural Equation Modeling*. Thousand Oaks, CA: Sage.
- Observatorio Permanente de la Inmigración. 2009. *Statistical Bulletin on Foreigners and Immigration to Spain #19*. Madrid: Ministerio de Trabajo e Inmigración (<http://extranjeros.mtin.es>)
- Ono, H. 2002. "Assimilation, Ethnic Competition, and Ethnic Identities of U.S.-Born Persons of Mexican Origin." *International Migration Review* 36:726-745.
- Pajares, M. 2009. "La inmigración en España: sus causas y las políticas con las que se gestiona" Pp. 175-192 in *Las migraciones en el mundo* edited by F. Checa Olmos, C. Checa, and A. Arjona. Barcelona: Icaria.
- Perlmann, J. 2005. *Italians Then, Mexicans Now: Immigrant Origins and Second Generation Progress 1980-2000*. New York: Russell Sage Foundation and the Levy Institute.
- Portes, A. and M. Zhou. 1992. "Gaining the Upper Hand: Economic Mobility Among Immigrant and Domestic Minorities." *Ethnic and Racial Studies* 15:491-522.
- Portes, A. and D. MacLeod. 1996. "What shall I call myself? Hispanic identity formation in the second generation." *Ethnic & Racial Studies* 19:523-547.
- Portes, A. and R. G. Rumbaut. 2001. *Legacies: The Story of the Immigrant Second Generation*. Berkeley, CA: University of California Press and Russell Sage Foundation.
- Rosenberg, M. 1965. *Society and Adolescent Self-Image*. Princeton, NJ: Princeton University Press.
- Rumbaut, R. G. 2004. "Ages, Life Stages, and Generational Cohorts: Decomposing the Immigrant First and Second Generations in the United States." *International Migration Review* 38 (Fall):1160-1205.

- Rumbaut, R. G. 2005. "Turning Points in the Transition to Adulthood: Determinants of Educational Attainment, Incarceration, and Early Childbearing among Children of Immigrants." *Ethnic and Racial Studies* 28 (November): 1041-1086.
- Rumbaut, R. G. and A. Portes. 2001. *Ethnicities: Children of Immigrants in America*. Berkeley: University of California Press and Russell Sage Foundation.
- Santa-Olalla, G. 2010. "La afluencia de inmigrantes se frenó en el 2009". *El Mundo*. April 30, pp. 17-18.
- Schneider, C. L. 2008. "Police Power and Race Riots in Paris." *Politics and Society*. 36(1): 133-159.
- Sotelo, I. 2005. "La gran contradicción europea." *El País* (Madrid), October 30. P. 15.
- Van Niekerk, M. 2007. "Second-Generation Caribbeans in the Netherlands: Different Migration Histories, Diverging Trajectories." *Journal of Ethnic and Migration Studies* 33:1063-1081.
- Torreblanca, J. I. 2010. "¿Dónde están los inmigrantes?" *El País*, January 25. P. 10.
- Vigil, J. D. 2002. *A Rainbow of Gangs: Street Cultures in the Mega-City*. Austin, TX: University of Texas Press.
- Waters, M. 1996. "West Indian Family Resources and Adolescent Outcomes." Paper presented at the meetings of the American Association for the Advancement of Science, Baltimore. February.
- Zarate, M. E., F. Bhimji, and L. Reese. 2005. "Ethnic Identity and Academic Achievement Among Latino/a Adolescents." *Journal of Latinos & Education* 4:95-114.
- Zhou, M. and C. N. Bankston III. 1996. "Social Capital and the Adaptation of the Second Generation: The Case of Vietnamese Youth in New Orleans." Pp. 197-220 in *The New Second Generation*, edited by A. Portes. New York: Russell Sage.
- Zhou, M., J. Lee, J. A. Vallejo, R. Tafoga-Estrada, Y. Soa Xiong. 2008. "Success Attained, Deterred, and Denied: Divergent Pathways to Social Mobility in Los Angeles' New Second Generation." *Annals of the American Academy of Political and Social Sciences* 620 (November): 37-61.

ALEJANDRO PORTES is Professor of Sociology and Director of the Center for Migration and Development at Princeton University. He is also Research Professor at the University of Miami. With Rosa Aparicio, he is co-directing the Longitudinal Study of the Second Generation in Spain (ILSEG) on which data this paper is based.

ADRIENNE CELAYA is a doctoral Sociology student at the University of Miami and has taken part in the statistical analysis of ILSEG as a research assistant.

ERICK VICKSTROM is a doctoral Sociology student at Princeton University. He he has taken part in the analysis of ILSEG results in the past and is co-author, with Portes and Aparicio, of several prior publications.

ROSA APARICIO is a research associate at the Ortega y Gasset Foundation in Madrid. Prior to directing ILSEG, she conducted, jointly with Andrés Tornos, several of the earliest studies about children of immigrants in Spain.

RECEIVED: 26 September 2011

ACCEPTED: 14 November 2011

APPENDIX. Descriptive statistics for variables used in analyses

Variable	Measurement Level	Range or value codes	Mean or proportion	Standard deviation	Median	25 th percentile	75 th percentile
Outcomes:							
Self-identification as Spanish	Dichotomous	1=Yes 0=No	.30	.46	.00	.00	1.00
Self-esteem	Interval	1-4	2.97	.44	3.00	2.70	3.30
Predictors (Endogamous):							
Parents	Educational Expectations	Interval	1-4	2.87	3.00	3.00	3.00
	Knowledge of Spanish index	Interval	1-4	3.55	3.75	3.25	4.00
Children	Inter-generational relations	Interval	1-4	3.09	3.00	2.67	3.67
	Experiences of discrimination	Interval	1= Never 2= Sometimes 3= Frequently	1.49	1.00	1.00	2.00
Predictors (Exogenous):							
	Family socioeconomic status	Interval	-1.48 to 3.63	.74	-.14	-.57	.37
Parents	Parental Knowledge of Spanish	Interval	1= 1-3 2= 3.25-3.75 3= 4	2.21	3.00	1.00	3.00
	Parental length of Spanish residence	Interval	1= 1-8 years 2= 9-11 years 3= 12-77 years	1.97	2.00	1.00	3.00
	Caribbean-Andean origin	Dichotomous	1=Yes 0=No	.53	1.00	.00	1.00
	Birthplace	Dichotomous	1=Spain 0=Abroad	.15	.00	.00	.00
Children	Age	Interval	12-19	13.91	14.00	13.00	15.00
	Sex	Dichotomous	1=Female 0=Male	.49	.00	.00	1.00