

Utah State University

DigitalCommons@USU

Space Dynamics Lab Publications

Space Dynamics Lab

1-1-2008

Wide-Field Infrared Survey Explorer Science Payload Update

Mark F. Larsen
Utah State University

Harri Latvakoski
Utah State University

Amanda K. Mainzer
Utah State University

Scott Schick
Utah State University

Joel Drake
Utah State University

Follow this and additional works at: https://digitalcommons.usu.edu/sdl_pubs

Recommended Citation

Larsen, Mark F.; Latvakoski, Harri; Mainzer, Amanda K.; Schick, Scott; and Drake, Joel, "Wide-Field Infrared Survey Explorer Science Payload Update" (2008). *Space Dynamics Lab Publications*. Paper 71.

https://digitalcommons.usu.edu/sdl_pubs/71

This Article is brought to you for free and open access by the Space Dynamics Lab at DigitalCommons@USU. It has been accepted for inclusion in Space Dynamics Lab Publications by an authorized administrator of DigitalCommons@USU. For more information, please contact digitalcommons@usu.edu.



Wide-field Infrared Survey Explorer Science Payload Update

Mark F. Larsen¹, Harri Latvakoski¹, Amanda K. Mainzer², Scott Schick³, Joel Drake¹

Space Dynamics Laboratory/Utah State University, Logan, UT, USA 84341¹

Jet Propulsion Laboratory, 4800 Oak Grove Dr., Pasadena, CA, USA 91109²

Practical Technology Solutions Inc., PO Box 6336, N. Logan, UT, USA 84341³

ABSTRACT

The Wide Field Infrared Survey Explorer is a NASA Medium Class Explorer mission to perform a high-sensitivity, high resolution, all-sky survey in four infrared wavelength bands. The science payload is a 40 cm aperture cryogenically cooled infrared telescope with four 1024² infrared focal plane arrays covering from 2.8 to 26 μm . Mercury cadmium telluride (MCT) detectors are used for the 3.3 μm and 4.6 μm channels, and Si:As detectors are used for the 12 μm and 23 μm wavelength channels. A cryogenic scan mirror freezes the field of view on the sky over the 9.9-second frame integration time. A two-stage solid hydrogen cryostat provides cooling to temperatures less than 17 K and 8.3 K at the telescope and Si:As focal planes, respectively. The science payload collects continuous data on orbit for the seven-month baseline mission with a goal to support a year-long mission, if possible. As of the writing of this paper, the payload subassemblies are complete, and the payload has begun integration and test. This paper provides a payload overview and discusses instrument status and performance.

Keywords: WISE, Infrared, Cryogenic, Infra-red Astronomy, Hydrogen cryostat

1. INTRODUCTION

1.1 WISE mission

The Wide-field Infrared Survey Explorer (WISE) is a cost-capped MIDEX program funded by NASA's SMD Universe Division, managed by the Jet Propulsion Laboratory (JPL), and led by Principal Investigator Edward Wright from UCLA¹. The WISE mission will map the entire sky from 2.8 to 26 μm with sensitivity unmatched by any previous survey mission, achieving over 500,000 times the sensitivity of Cosmic Background Explorer (COBE) at 3.5 and 4.7 μm and a thousand times that of Infrared Astronomical Satellite (IRAS) at 12 and 25 μm . WISE will establish an essential database for testing theories of the origins of planets, stars, and galaxies and is a precursor for the James Webb Space Telescope (JWST).

The WISE science payload will operate in a single mode, continuously imaging portions of the sky as the sun-synchronous, 530-km orbit precesses around the celestial sphere. Following a month of in-orbit checkout, the all-sky survey will take 6 months to complete. Each focal plane, with a 1024x1024 pixel array and 2.75 arc second pixels, will cover a 47 arc minute field of view. The payload includes a cryogenic scan mirror to offset the orbital motion and freeze the sky during each 11 second frame—an 8.8 second integration time, plus 1.1 seconds each for readout and mirror flyback. Data will be processed using a sample up-the-ramp^{2,8} technique.

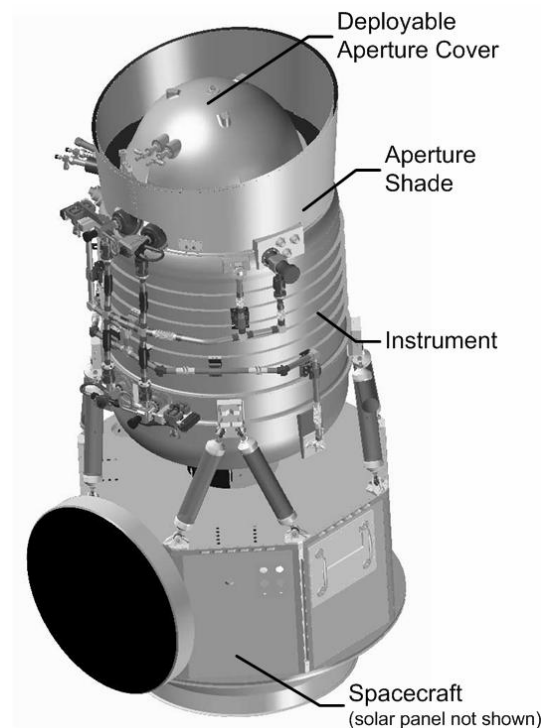

Figure 1: WISE flight system including the science payload and spacecraft bus

The orbit precesses in ecliptic longitude by 1 degree per day or 4 arc minutes per orbit. The minimum number of exposures for any point on the sky is 8, accounting for a 10% frame-to-frame overlap and a 90% orbit-to-orbit overlap and planned outages for the moon, SAA, data downlink, and other outage events.

Mission elements include a science payload, spacecraft bus, mission operation and data processing¹. Utah State University/Space Dynamics Laboratory (SDL) and Ball Aerospace Technology Center (BATC) are, respectively, under contract to provide the science payload and the spacecraft bus for the 750-kg WISE flight system (Figure 1). This paper describes the science payload, which consists of the cryogenically-cooled, IR instrument and control/ data collection electronics. As seen in Figure 1, the payload mounts to the top of the spacecraft bus via a composite bi-pod support structure, which provides structural support for the payload and the necessary thermal isolation from the spacecraft.

This payload has strong legacy to previous solid hydrogen-cooled infrared instruments built at SDL, such as SPIRIT III² and WIRE^{4,5}, and continues to apply lessons learned from these programs.

As the expendable cryogen is the limiting factor for mission life, the cryostat has been designed with increased cryogen margins for risk mitigation and the potential for an extended year-long data collection mission.

2. SCIENCE PAYLOAD DESCRIPTION

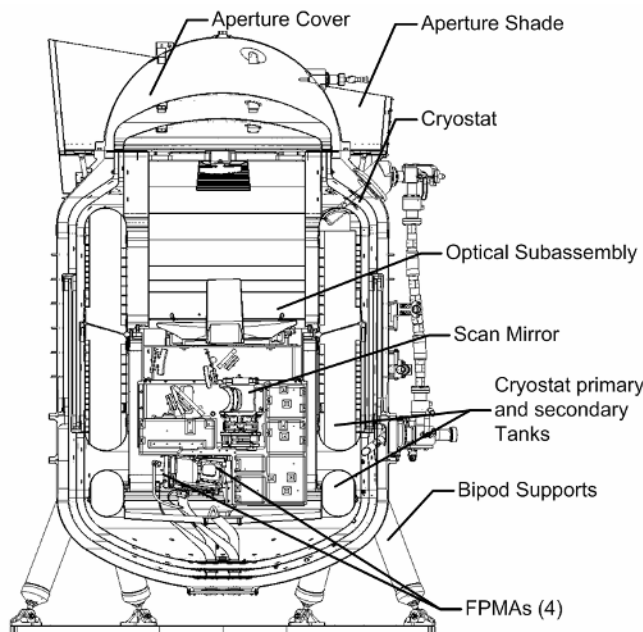

Figure 2: Payload cut-away view showing major components

Table 1: Predicted Payload Performance

PARAMETER	PREDICTED PERFORMANCE			
	Band 1	Band 2	Band 3	Band 4
Bands (μm)	2.8 – 3.8	4.1 – 5.2	7.5 – 16.5	20 – 26
Sensitivity*(μJy)	64	105	512	2496
Image Quality (noise pixels)	13.5	16.6	37.1	27.0
Field of View	46.9' by 46.9' \pm 5%			
Mass	330 kg			
Power	113 Watts			
FPA cooling	7.8 \pm 0.5 K for Bands 3,4 32.0 \pm 2.0 K for Bands 1,2 (heater controlled)			
Cryogen life	12.8 months			

* Based on 8 observations and a SNR of 5

The science payload (Figure 2) is a cryogenically cooled, infrared imaging telescope, covering four infrared bands (see Table 1). It consists of an optical subassembly and four focal planes contained within a two-stage, solid hydrogen cryostat. Warm electronics mounted within the spacecraft control the scan mirror, process data, and monitor system health and telemetry.

Performance predictions based on available measurements are shown in Table 1. In the subsections

that follow, we describe the optical subassembly, focal planes, cryogenic support system, operating electronics and the upcoming test program. More detailed descriptions were published previously².

2.1 Optical subassembly

The WISE optical subassembly (see Figure 3) includes an afocal telescope, a scan mirror, imaging optics, and the beamsplitter assembly (BSA). The afocal telescope, scan mirror, and imaging optics were designed and fabricated by L-3 SSG-Tinsley⁶. The optical subassembly mounts into the cryostat and is structurally and thermally tied to the cryostat via the interface flange. The scan mirror is placed in collimated space between the afocal optics and the imaging optics and holds the field of view steady on the sky as the spacecraft rotates in its orbit. Parameters of the optical subassembly are shown in Table 2.

Table 2: Key optical subassembly parameters

Parameter	Performance			
Field of View	46.9 x 46.9 arc minutes (0.783 x 0.783 degrees)			
Field of Regard	46.9 x 86 arc minutes (0.783 x 1.433 degrees)			
Focal length	1.35 m (53.15 inches)			
Aperture diameter	40 cm (15.75 inches)			
F#—(Focal-length)/ (Aperture-diameter)	3.375			
RMS WFE (633 nm waves)	Band 1	Band 2	Band 3	Band 4
	0.743	0.827	0.989	1.150
Obscuration	19.4% by area			
Mean Afocal Distortion	< 1 pixel			
Overall Distortion	Mean: 0.9185 pixels (1 pixel=18µm) Worst Case: 2.288 pixels (1 pixel=18 µm)			
Afocal module	Number of mirrors: 6 Magnification: 8			
Imager module	Number of mirrors: 6			
Imager Field of View	6.264 x 6.264 degrees			
Scan mirror (flat)	Scan range (adjustable): 25' to 39' (object space) or 100' to 156' (shaft angle) Retrace time: < 1.1 sec.			
Scanner Linearity	< 5 arcsec			
Operating temperature	< 17 K			
Total reflectance	85%			

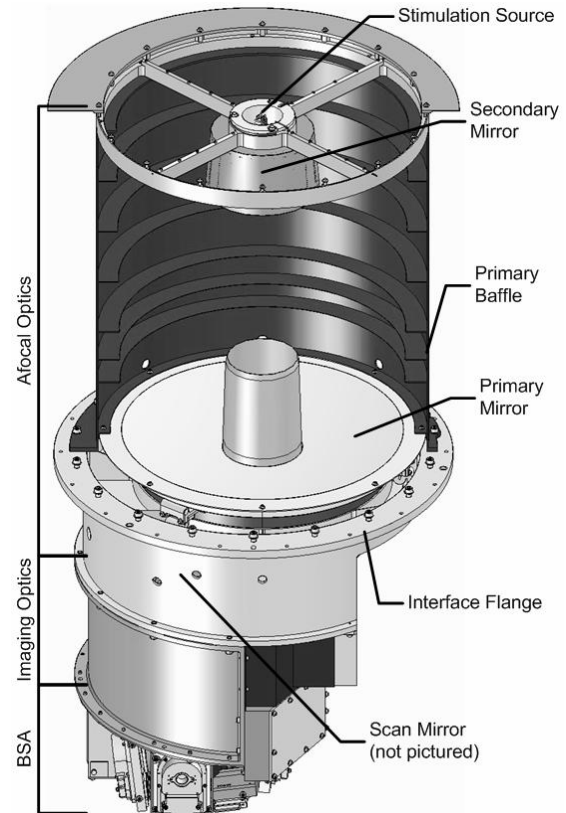

Figure 3: Optical subassembly

2.1.1 Telescope

The telescope is a 13-mirror, all-aluminum system that uses gold-coated, bare-polished aluminum mirrors. The cryogenic scan mirror is placed in collimated space between the afocal telescope and the imaging optics. The optics operate at less than 17 K to keep the instrument background low. Since the telescope was designed to be modular, the afocal optics, imaging optics, and scan mirror were developed and tested in parallel.

2.1.2 Beam splitter assembly

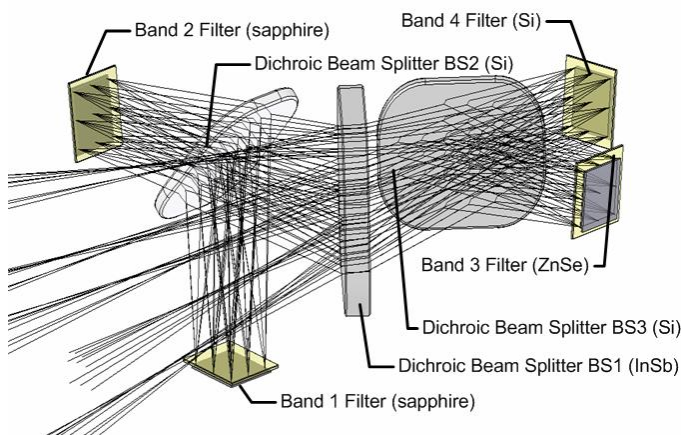

Figure 4: Beam splitter assembly

Filters for bands 1 and 2 use a sapphire substrate. The band 3 filter uses ZnSe, and Band 4 uses a Silicon substrate.

The BSA is an aluminum structure that holds three beam splitters that separate the light from the imager into the four bands. The optical layout for the BSA is shown in Figure 4. The BSA provides the physical interface between the imager and the focal planes.

Composite thermal isolators are used between the FPMA mounts for bands 3 and 4 and the BSA, providing the thermal isolation needed to achieve the lower temperatures for the two Si:As FPAs, which are thermally strapped to the primary tank. Heaters are provided so these FPAs can be annealed on orbit, if necessary.

Filters are mounted as close as possible to each FPA to increase out-of-band rejection and reduce ghosting and the Stierwalt effect.

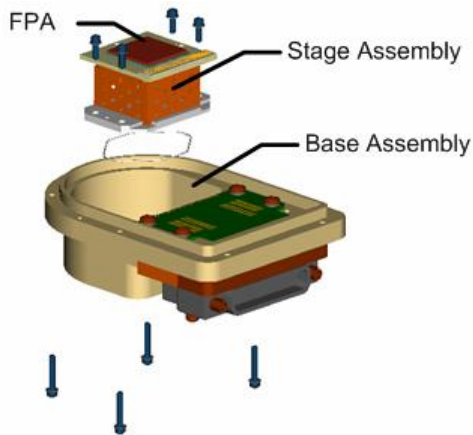

Figure 5 FPMA Construction

Table 3: Key FPA parameters

Parameter	Si:As Performance	HgCdTe Performance
Format	1024 ² , 18- μ m	1024 ² , 18- μ m
QE	>60%	>70%
Noise (CDS)	100 e ⁻	20 e ⁻
Dark current	<100 e ⁻ /s	<1 e ⁻ /s
Dynamic Range	100,000 e ⁻	100,000 e ⁻
Operating temperature	7.8 K	32 K
Power dissipation	3.7 mW	6.7 mW

Table 4: Key Cryostat Performance Parameters

Parameter	Predicted performance
Lifetime	12.8 months
Ground Hold Time	44 hours
Temperatures	7.6 K \pm .5 K (primary) <13K (secondary)

cover is fastened to the cryostat with pyro-actuated separation nuts and will be jettisoned on orbit.

The cryogen tank vent valves are also pyro-actuated. Cryogens from the secondary tank will be vented through two low thrust vents to reduce any torque caused by the exiting hydrogen. Primary tank vent rates are not high enough to impart significant torque on the flight system.

To limit the parasitic loads into the cryogen, the vacuum shell will operate below 200 K on orbit. This is made possible by taking advantage of the sun synchronous orbit and insulating the sun-facing side of the instrument with MLI blankets and leaving the space-facing side open to radiate to space. By using a high-emissivity/low-absorptivity coating on the outside

2.2 Focal planes

WISE uses four FPAs to capture data in its four IR bands. These advanced devices allow the sensitive, high-resolution all-sky survey. DRS Sensors and Targeting Systems, Inc. provided the four FPMAs, cables, and electronics to SDL for integration. Bands 1 and 2 use MCT arrays and readouts produced by Teledyne Technologies, Incorporated.

Bands 3 and 4, the long-wavelength bands, use arsenic-doped silicon blocked impurity band arrays (Si:As), produced by DRS. Key performance parameters for the FPAs are listed in Table 3. Both types of FPA use a common mount to interface to the BSA. Slight differences in the FPAs are accounted for in the cold electronics on the FPMAs and an isolator that allows the MCT arrays to operate at a higher temperature than the base. The mount design is illustrated in Figure 5.

2.3 Cryogenic support system

The cryogenic support system consists of the dual stage solid-hydrogen cryostat, the aperture shade, and the bi-pod support structure that interfaces the instrument to the spacecraft. Each of these components is essential to the optical and thermal performance.

2.3.1 Cryostat

The WISE cryostat⁷ below, provided by Lockheed-Martin, is a dual-stage solid hydrogen design consisting of two cryogen tanks housed within a vacuum shell. Figure 6 illustrates the cryostat design. This design provides two separate cooling zones. The secondary tank operates at 10.2 K; cools the optical subassembly to less than 17 K; and absorbs the parasitic heat loads from the outer shell, environment, MCT arrays, and telescope. The 7.3-K primary tank is mounted off the secondary tank and cools only the Si:As FPMAs. The heat loads and the size of the vent lines to space define the vapor pressure and temperature of each cryogen tank.

The aperture cover seals the vacuum space and protects cryostat interior and the optical subassembly during ground and launch operations. The

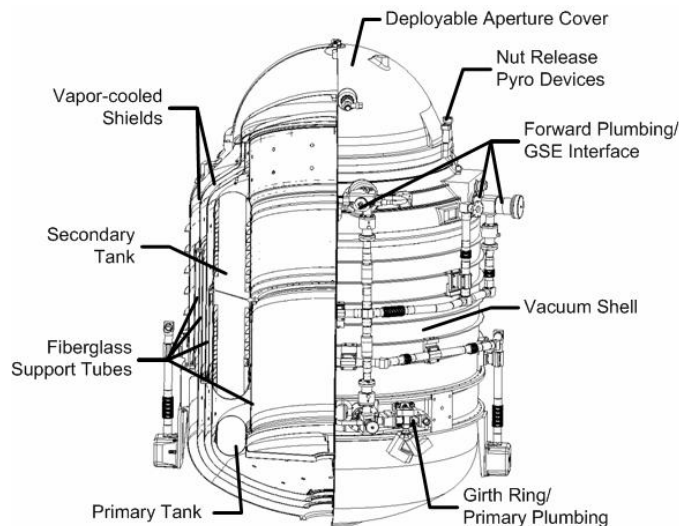

Figure 6: Cryostat

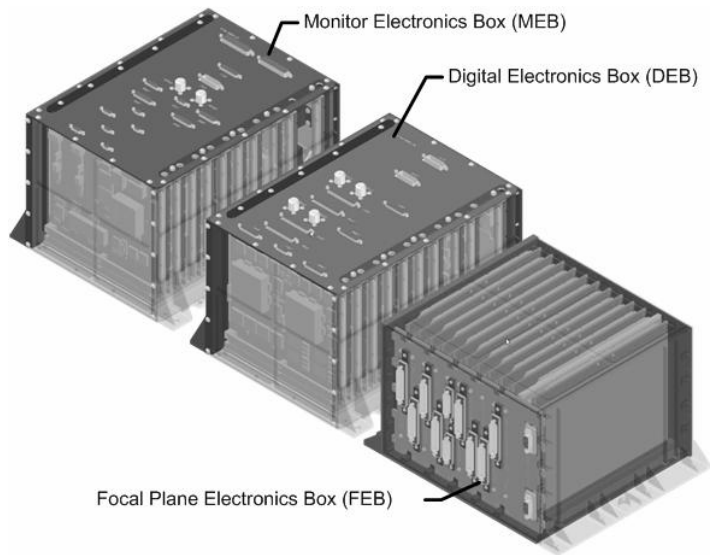

Figure 7: Payload electronics

integration of the bi-pod fixtures.

2.4 Electronics

The payload electronics (Figure 7) control the focal planes and the scan mirror, process data, monitor system health and telemetry, and fire the payload pyro devices. The electronics are housed in three boxes, mounted to the spacecraft walls.

The Monitor Electronics Box (MEB) monitors payload health, controls the scanner, focal plane annealing heaters, and pyrotechnic devices for releasing the aperture cover and opening the orbit vents. The Focal Plane Electronics Box (FEB) controls the focal planes and digitizes raw focal plane data. The Digital Electronics Box (DEB) performs sample up-the-ramp⁸ processing on the digital focal plane data from the FEB and transmits the processed data to the spacecraft. The electronics synchronize the start of the focal plane data collection and scan mirror movement so that data is collected while the images are held stable on the sky. The scan mirror retraces at the end of each frame and the process repeats. The WISE payload is designed to collect data in one mode continuously.

3. INTEGRATION AND TEST

Because WISE has a modular design, subsystems were tested as they were integrated. Figure 9 shows a simplified integration and test flow. In general, subsystems undergo functional and protoflight-level environmental testing prior to integration. The majority of cold testing is done using liquid helium and ground heaters to achieve operating temperatures.

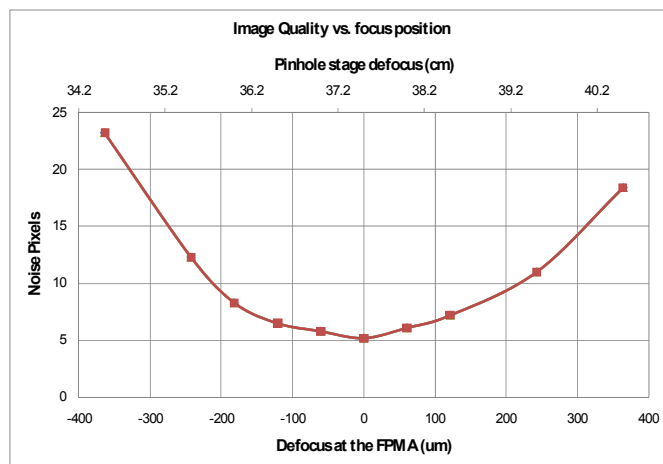

Figure 8: Best focus for Band 1 during imaging module testing.

of the blanket, the design is able to achieve the low shell temperatures.

2.3.2 Aperture shade

The two-stage aperture shade reduces the impact of environmental heat loads on the open aperture and supports limited pointing capability for the flight system to shift around the moon and point to TDRSS to downlink the science data. The inner stage of the shade is gold-coated and includes a radiator to cool it to approximately 100 K to reduce inner surface self emissions into the open cryostat

2.3.3 Bipods

The WISE payload is supported off the spacecraft top deck by four S2-glass fiber wound composite bipods. These provide structural support and thermally isolate the payload from the spacecraft. A simple mounting pad at the cryostat and a clevis foot at the spacecraft deck provide straightforward

3.1 Integration and test status

The first step in the integration process (Figure 9) was to assemble the BSA, flight focal planes, and the imaging module. Best focus at cryogenic temperatures was then obtained using a warm collimator as follows: A blackbody with a precision pinhole was used as the source. By moving the pinhole axially and measuring the image quality (noise pixels) at each pinhole location, the position of optimal focus is obtained⁹. The position of the pinhole that gives the best focus for WISE in this configuration is then compared to the position that defines optimal focus of the collimator.

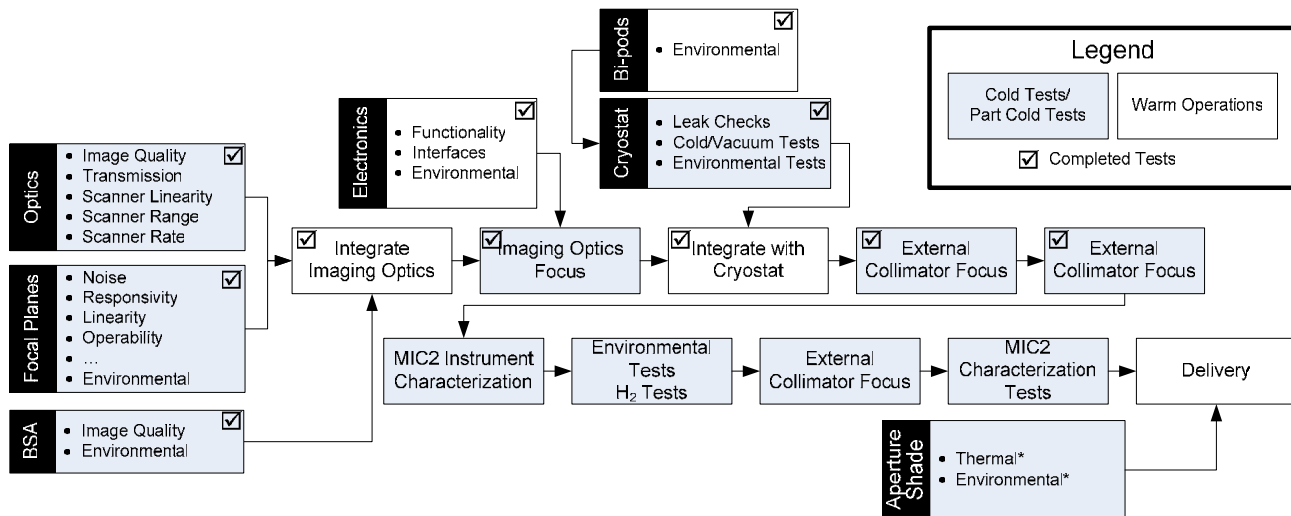

Figure 9: Simplified Integration Flow



Figure 10: Instrument assembly

The imager assembly and the afocal telescope were next integrated to form the optical subassembly (OSA), which includes the afocal telescope, the imager, the BSA, and the focal planes. Due to delays in the scan mirror fabrication, the scanner was not included at this time. This assembly was next integrated into the cryostat. The payload, consisting of the OSA, the cryostat, and the flight electronics, was then tested for focus using a warm external collimator. In this configuration, a long cylinder with

The difference multiplied by the square of the ratio of the WISE focal length and the collimator focal length defines the distance the WISE focal planes need to be moved to achieve optimal focus. The focal planes are then shimmed to the correct, in-focus, position. For these tests, the payload is operated with a warm external window and a cold ND8 filter to reduce the background. Since the afocal optics were predicted to introduce both piston and tilt to the best plane of focus, the goal of this test was to obtain confocality. Two focus cycles were performed, which resulted in acceptable confocality. Figure 8 illustrates the band 1 image quality at the focal plane for the imager-only test as a function of the defocus at the FPMA (lower horizontal axis) and the location of the pinhole on the axial stage (upper horizontal axis). The image quality budget allowance for focus ranges from $\pm 50 \mu\text{m}$ for the 2.8 to 3.8 μm band, and $\pm 200 \mu\text{m}$ for the 20 to 16 μm band.

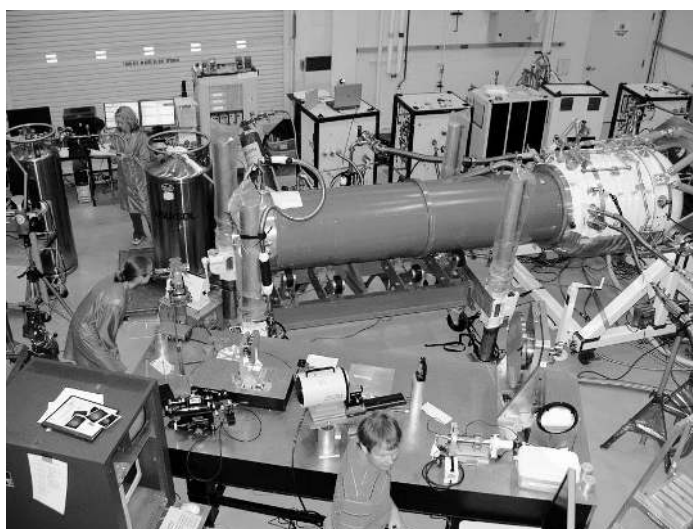

Figure 11: External collimator focus testing

a fused silica window was attached to the cryostat. Heat loads into the aperture and onto the external window are reduced using LN2 cooled shields.

3.2 Integration and test plan

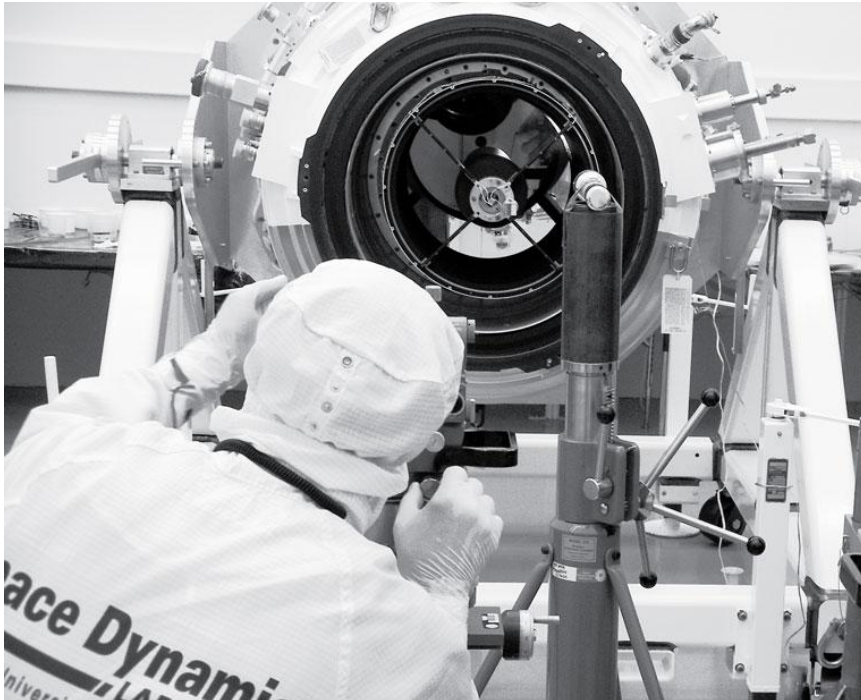

Figure 12: Optical boresight transfer

Future work to complete the payload includes characterization, environmental, and final acceptance testing for the payload.

The integrated payload will be tested for focus, image quality, sensitivity, and spectral responsivity using SDL's multifunction infrared calibrator (MIC2). This IR test facility has been used on multiple DOD and NASA programs. The focused assembly will be mounted inside the cryostat which interfaces to the MIC2 exit port. MIC2 shares the vacuum space with the cryostat and has several externally configurable modes that will allow many aspects of WISE to be tested without having to break the vacuum or warm up.

The electro-optical parameters measured for WISE fall generally into two categories: those that are used in the radiance characterization equation, which relates sensor response to measured radiance (e.g., dark offset, non-linearity, flat-fielding) and those that are used as part of a more general sensor model (e.g., optical distortion, relative spectral responsivity).

The peak irradiance responsivity, or sensitivity to a point source, is calculated based on the image quality (measured in noise pixels taken from the point response function) and the peak radiance responsivity. Other parameters, such as the relative spectral responsivity, are measured using MIC2.

In parallel with electro-optical testing performed using MIC2, subsystem structural testing will continue and the flight cover and ejection mechanism will be tested using cold-gas actuation. The cover ejection design has been utilized on two previous missions. The design includes three

Table 5: Electro-optical characterization measurements and configuration.

Test Types	Measurement Configuration	Parameters	Requirement					
			Bands	Sensitivity	Image Quality	Field of View	Saturation Flux Density	Out-of-band rejection
Focus	MIC2 and blue tube Collimators	Focus			X			
Radiometric	MIC2 (Extended, Scatter, and Collimator Source)	Dark offset		X				
		Gain variation		X				
		Non-Linearity Correction		X			X	
		Saturation effects					X	
		Flat field (non-uniformity)		X			X	
		Absolute Responsivity		X			X	
Image Quality	MIC2 and blue tube Collimators	Nominal Pixel Mask		X				
		PRF		X	X	X		
		Scanner Pointing		X	X			
		Near angle scatter		X	X			
Spectral Response	MIC2 Scatter source with Step-scan interferometer	Distortion map		X	X			
		In-band Spectral Responsivity	X	X				
		Out-of-band Spectral Responsivity						X

separation nuts, each with redundant initiators, and six spring plunger assemblies that push the cover off once the fasteners are released on-orbit. The firing circuitry fires both the primary (side A) and secondary (side B) actuators when commanded. However, the side B initiators are fired after a slight delay. Consequently, the cover will be tested with various combinations of delays to simulate failures of either one or two side A initiators.

Stimulation sources mounted on the secondary mirror provide a stable source that can be used during integration with the spacecraft bus and during launch operations to verify and trend sensor performance without the need for an external source.

After structural environmental tests, a payload thermal test is performed using solid hydrogen. In this test, the cryostat is loaded with solid hydrogen using the same procedure as will be used during launch operations. Heat rates and ground hold measurements will be made during this test sequence to correlate the models used for on-orbit life prediction.

The final group of tests verifies nothing has changed from the environmental testing and finishes the characterization of the payload. Focus and image quality are compared to results obtained before structural testing, using the external collimator, then final image quality, spectral responsivity, noise, and sensitivity testing is performed.

4. SUMMARY

The payload subsystems have been completed and have been integrated, and the payload has begun the integration and test phase of the program. Preliminary data suggest that the payload is functioning well, and will be ready for integration with the spacecraft in the Spring of next year.

5. ACKNOWLEDGEMENTS

The work described in this paper is being performed under contract with the Jet Propulsion Laboratory, California Institute of Technology for the National Aeronautics and Space Administration.

BIBLIOGRAPHY

1. A.K. Mainzer, P. Eisenhardt, E.L. Wright, F. Liu, W. Irace, I. Heinrichsen, R. Cutri, V. Duval "Update on the Wide-Field Infrared Survey Explorer (WISE)," Proc. SPIE Vol. 6265, p. 625-636, Space Telescopes and Instrumentation I: Optical, Infrared, and Millimeter; Jul 2006
2. M.F. Larsen, S.H. Schick. "Wide-field Infrared Survey Explorer science payload overview" Proc. SPIE Vol. 5904, p. 166-177, Date: Aug 2005
3. S. Schick, G. Bell. "Performance of the SPIRIT III cryogenic system," Proc. SPIE Vol. 3122, p. 69-77, 1997.
4. B. Costanzo, P. Menteur, S. Schick, W. Foster. "Design and performance analysis of the wide-field infrared explorer H2/H2 cryostat," Proc SPIE Int. Soc. Opt. Eng., 2814, p. 147-153, 1996.
5. D. Everett, T. Correll, S. Schick, K. Brown. "Recovery of the Wide-Field Infrared Explorer Spacecraft," Proc. AIAA/USU Conf. on Small Satellites, SSC00-V-1, 2000.
6. M. Schwalm, M. Berry, K.E. Kosakowski, G. Perron, D. Sampath, B. Crowther. "Cryogenic telescope, scanner, and imaging optics for the Wide-field Infrared Survey Explorer (WISE)," Proc SPIE Int. Soc. Opt. Eng. 5904-20, 2005.
7. L.G. Naes, S. Wu, J.C. Cannon, B. Lloyd, S. Schick. "WISE solid-hydrogen cryostat design overview," Proc SPIE Int. Soc. Opt. Eng. 5904-41, 2005.
8. J.D. Garnett, W.J. Forrest. "Multiply sampled read-limited and background-limited noise performance," SPIE Vol. 1946, Infrared Detectors and Instrumentation, 1993.
9. J. J. Tansock, A. L. Shumway, "Focus optimization of the SPIRIT III radiometer", Opt. Eng. Vol 36, November 1997, p. 2936-2942.