



AALBORG UNIVERSITY
DENMARK

Aalborg Universitet

Wind Energy Systems

Blaabjerg, Frede; Ma, Ke

Published in:
Proceedings of the IEEE

DOI (link to publication from Publisher):
[10.1109/JPROC.2017.2695485](https://doi.org/10.1109/JPROC.2017.2695485)

Publication date:
2017

Document Version
Publisher's PDF, also known as Version of record

[Link to publication from Aalborg University](#)

Citation for published version (APA):
Blaabjerg, F., & Ma, K. (2017). Wind Energy Systems. *Proceedings of the IEEE*, 105(11), 2116-2131. [17259997]. <https://doi.org/10.1109/JPROC.2017.2695485>

General rights

Copyright and moral rights for the publications made accessible in the public portal are retained by the authors and/or other copyright owners and it is a condition of accessing publications that users recognise and abide by the legal requirements associated with these rights.

- Users may download and print one copy of any publication from the public portal for the purpose of private study or research.
- You may not further distribute the material or use it for any profit-making activity or commercial gain
- You may freely distribute the URL identifying the publication in the public portal -

Take down policy

If you believe that this document breaches copyright please contact us at vbn@aub.aau.dk providing details, and we will remove access to the work immediately and investigate your claim.

Wind Energy Systems

This paper reviews application of power electronics in wind energy systems.

By FREDE BLAABJERG, *Fellow IEEE*, AND KE MA, *Member IEEE*

ABSTRACT | Wind power now represents a major and growing source of renewable energy. Large wind turbines (with capacities of up to 6–8 MW) are widely installed in power distribution networks. Increasing numbers of onshore and offshore wind farms, acting as power plants, are connected directly to power transmission networks at the scale of hundreds of megawatts. As its level of grid penetration has begun to increase dramatically, wind power is starting to have a significant impact on the operation of the modern grid system. Advanced power electronics technologies are being introduced to improve the characteristics of the wind turbines, and make them more suitable for integration into the power grid. Meanwhile, there are some emerging challenges that still need to be addressed. This paper provides an overview and discusses some trends in the power electronics technologies used for wind power generation. First, the state-of-the-art technology and global market are generally discussed. Several important wind turbine concepts are discussed, along with power electronics solutions either for individual wind turbines or for entire wind farms. Some technology challenges and future solutions for power electronics in wind turbine systems are also addressed.

KEYWORDS | Control; grid codes; power electronics; power semiconductor devices; topology; wind farm; wind power generation; wind turbine system

I. INTRODUCTION

The cumulative installation of wind turbines has grown at a fast pace over the last two decades. Installed wind power generation, which is currently larger than 440 GW, is expected to exceed 760 GW by 2020, making this form of renewable energy a significant component of the modern and future energy supply systems [1]–[3]. Along with the fast-growing capacity, the power electronics technologies used for wind turbine systems (WTSs) have also changed dramatically in the last 30 years [4]–[12].

In the 1980s, the power electronics in wind turbines was simply a soft-starter, which is used to initially interconnect a

squirrel-cage induction generator (SCIG) with the power grid when the wind turbine starts to produce power. Because power electronics did not need to carry power continuously, simple power semiconductor device such as thyristors were applied. In this solution, the rotational speed of the generator is fixed; thus, the wind-speed fluctuations are directly reflected as mechanical-torque fluctuations and then current fluctuations of the generator. Therefore, this solution requires a “stiff” power grid, and its mechanical construction must be able to support the high mechanical stress caused by wind gusts. Moreover, the wind turbine cannot operate at its maximum efficiency in a broad range of wind speeds, and thereby has reduced energy yield.

In the 1990s, power electronics technology was mainly used for rotor resistance control of wound-rotor induction generators (WRIGs), in which more advanced power electronics devices such as diode bridges and choppers were used to control the rotor resistance for the generator. In this solution, the rotational speed of the wind turbine can vary in a limited range, especially at the nominal power operation of the wind turbine (typically 0%–10% above the generator’s synchronous speed); thus, the mechanical stress in the system can be relieved.

Since 2000, even more advanced voltage source converters with bidirectional power flow have been introduced; the power electronics started to handle the generated power from the wind turbines continuously, first, by partial scale of power capacity for doubly fed induction generators (DFIGs), and then by the full scale of power capacity for asynchronous or synchronous generators (A/SGs) [5]–[7]. By introducing power electronics converters, it is possible to fully control the rotational speed of the generator and acquire many benefits: First, the wind-speed fluctuations can be smoothly converted into mechanical torque and electrical power with certain inertia by utilizing the kinetic energy in the blades. Moreover, wind turbine efficiency can be optimized over a broader range of wind speeds. Meanwhile, some ancillary services can also be provided for the grid thanks to the extra power control flexibilities introduced by power-electronics converters.

Manuscript received February 15, 2017; revised March 27, 2017; accepted March 29, 2017. Date of publication May 16, 2017; date of current version October 18, 2017. (Corresponding author: Frede Blaabjerg.)

F. Blaabjerg is with Aalborg University, Aalborg, Denmark (e-mail: fbl@et.aau.dk).

K. Ma is with the Department of Electrical Engineering, Shanghai Jiao Tong University, Shanghai, China (e-mail: kema@sjtu.edu.cn).

Digital Object Identifier: 10.1109/JPROC.2017.2695485

0018-9219 © 2017 IEEE. Translations and content mining are permitted for academic research only. Personal use is also permitted, but republication/redistribution requires IEEE permission. See http://www.ieee.org/publications_standards/publications/rights/index.html for more information.

It can be seen that power electronics have become more advanced with growing capacity coverage, and have brought significant performance improvements to wind turbines—not only reducing mechanical stress and increasing energy yield, but also enabling the WTS to act as a controllable generator much more suitable for integration with the power grid.

The scope of this paper is to provide a status overview of the technologies and discuss some technology trends in the power electronics used for wind power applications. First, the technology and market developments of wind power generation are generally reviewed. Next, the power electronics technology for individual wind turbines and for wind farms is addressed. Further, the emerging challenges for the power electronics technology in wind turbines as well as the future solutions are discussed.

II. DEVELOPMENT OF WIND POWER GENERATION AND POWER ELECTRONICS

Wind power has truly become an important component of the modern energy supply. The cumulative wind power capacity from 2001 to 2020 is shown in Fig. 1; the installed capacity of wind power achieved 487 GW, with 54 GW added in 2016 alone. Wind power accounted for 55% of the renewable power capacity globally, not including hydropower, and accounted for 3.7% of global electricity production by the end of 2015 [1]–[3]. Several European countries have achieved relatively high levels of wind power penetration, including Denmark (42%), Portugal (23.2%), Ireland (23%), Spain (18%), Germany (13.3%), and the United Kingdom (11%). Other major wind power markets also have a significant amount of wind energy shares in their power generation, including the United States (4.7%), China (3.3%), and Brazil (3%). As an important milestone, on November 3, 2013, Denmark for the first time set a record by having wind

power production in excess of power consumption at the national level [11]; and it now happens regularly.

The individual size and the power rating of wind turbines have also increased dramatically. The emerging sizes of wind turbines between 1980 and 2020 are illustrated in Fig. 2, where the development of power electronics with its rating coverage and functional role are also indicated. In 2015, the average rating of wind turbines installed in Europe was 2.7 MW for onshore and 4.2 MW for offshore, and now cutting-edge 8-MW wind turbines with a diameter of 164 m are on the market [12]. Today the major wind turbine manufacturers have issued products in the power range of 4–6 MW, and it is expected that more wind turbines above 4 MW will be erected in the next decade (with 10-MW prototypes also available); this trend is mainly driven by the need to reduce the cost of energy per produced kilowatt hour [13].

With respect to the wind power markets and manufacturers in 2015, China was the largest market with over 30 GW newly added in 2015, together with the United States (8.6 GW) and the European Union (12.8 GW) sharing approximately 82% of the global market [1]. Table 1 summarizes the top suppliers of wind turbines with the size and capacity of their main products in 2015. The companies from China, the United States, and Europe dominated the market shares with wind turbines of 1.5–3.5 MW in the mainstream and 5–8 MW at the high end in terms of power level.

III. POWER ELECTRONICS TECHNOLOGY FOR INDIVIDUAL WIND TURBINES

The main components employed for energy conversion from wind to electricity in a typical WTS include the rotor with the turbine blades, possibly a gearbox (which is eliminated in direct-drive solutions), an electric generator, a power electronics converter, and a transformer, as illustrated in

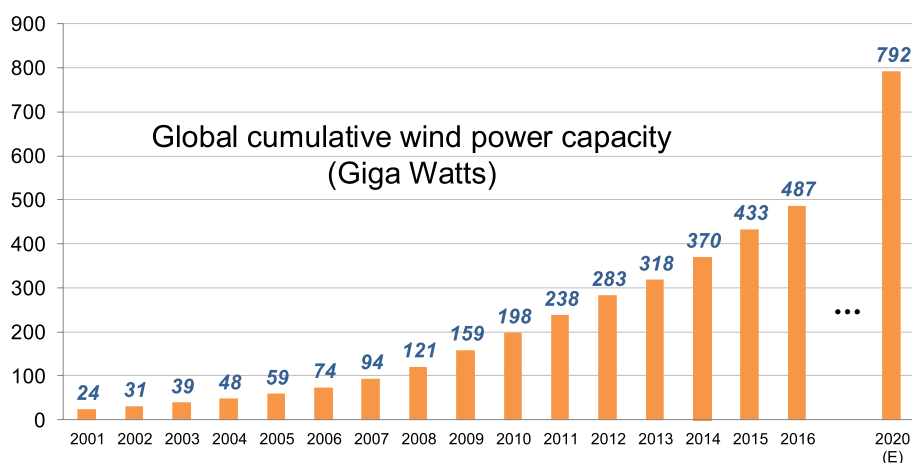

Fig. 1. Global cumulative wind power capacity from 2001 to 2020 [1].

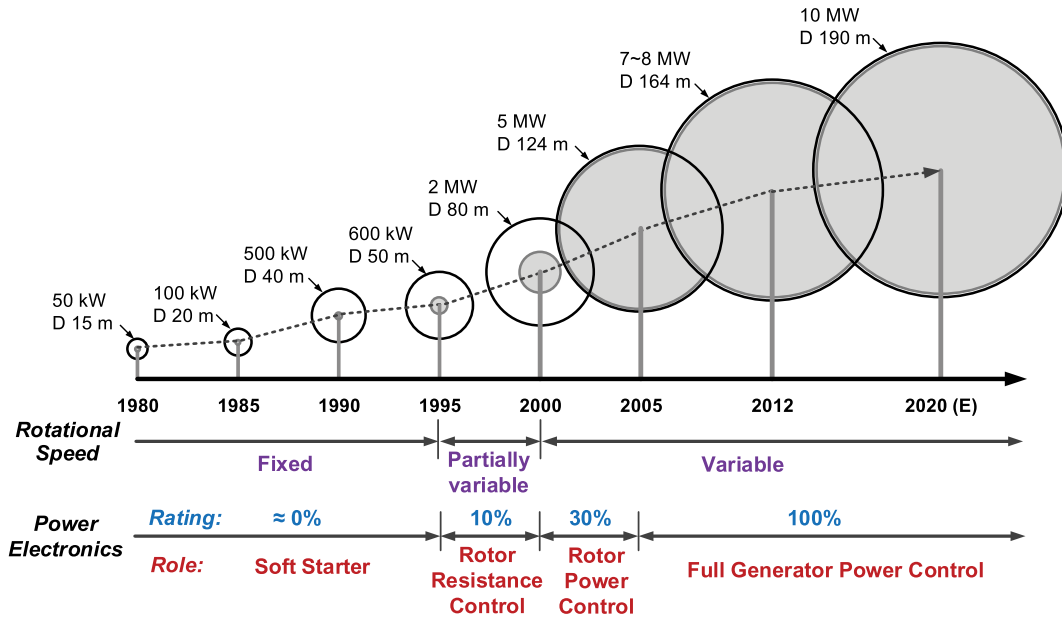

Fig. 2. Developments of power electronics for the wind turbines between 1980 and 2020 (E); gray area inside the turbine circle indicates the power rating coverage by power electronics; D means diameter of the rotor.

Fig. 3 [14]. Wind turbine designs can be categorized into several concepts depending on the type of generator, speed controllability, and approach by which the aerodynamic power is limited [5]–[7]. In these wind turbine concepts, the power electronics plays quite different roles and has different power coverages of the system, as shown in Fig. 2. In the last decade, the concept of the DFIG equipped with a partial-scale power electronics converter dominated the market, but now the configuration with an SG or AG equipped with a full-scale power electronics converter is gaining popularity because it has full power controllability [1].

A. Doubly Fed Induction Generator With Partial-Scale Power Electronics Converter

This concept is the most adopted solution so far and has been erected extensively since 2000, as shown in Fig. 4, where a DFIG with a multistage gear box is adopted in the system. The stator windings of a DFIG are directly connected to the power grid through a transformer, and the rotor windings are connected to the power grid through a power electronics converter with approximately 30% power capacity of the generator [15]–[17]. In this concept, the frequency and the current in the rotor of the generator are flexibly

Table 1 Top Wind Turbine Manufacturers and Product Lines in 2015

Rank	Manufacturer	Global Market shares	Rotor diameter	Power range
1	Goldwind (China)	12.5 %	70-121 m	1.5-3 MW
2	Vestas (Denmark)	11.8 %	90-136 / 164 m	1.8-3.45 / 8 MW
3	GE Wind (USA)	9.5 %	83-137 / 150 m	1.7-3.8 / 6 MW
4	Siemens Wind (Denmark/Germany)	8.0 %	101-142 / 154 m	2.3-4 / 6-8 MW
5	Gamesa (Spain)	5.4 %	80-132 / 132 m	2-3.3 / 5 MW
6	Enercon (Germany)	5.0 %	44-141 m	0.8-4.2 MW

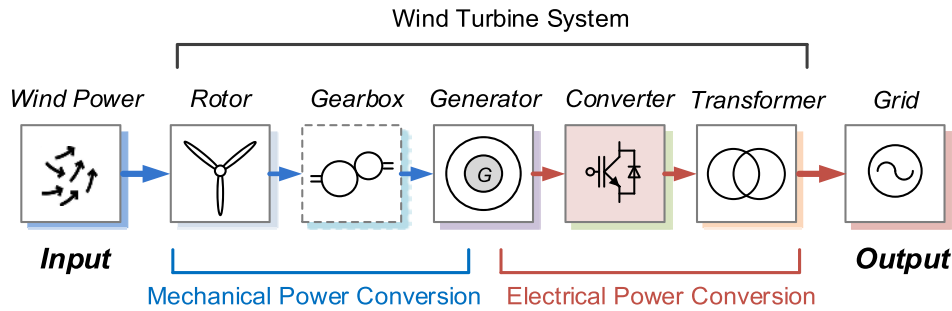

Fig. 3. Power conversion stages in a typical WTS (gear box is avoided in some systems).

controlled by the power electronics, and thus the rotational speed of rotor blades can be varied in a satisfactory range to maximize the energy yield and reduce the mechanical stress. The relatively small capacity of the power converter makes this concept attractive from a cost point of view. However, its main drawbacks are the use of slip rings with compromised reliability and insufficient power controllability in the case of grid or generator disturbances [18]–[20].

Because the power rating requirement for the power electronics converter is relatively small, the two-level voltage source converter (2L-VSC) topology is most adopted in the DFIG-based wind turbine concept. Normally, two 2L-VSCs are configured in a back-to-back solution through a common direct current (dc) link, as shown in Fig. 5. A technical advantage of this back-to-back solution is full power controllability under four-quadrant operation; this solution also has a relatively simple structure with a small component count, which contributes to well-proven reliability as well as the benefit of low cost.

B. Asynchronous/Synchronous Generator With Full-Scale Power Converter

Another important concept, which is popular for newly installed wind turbines, is shown in Fig. 6. The SCIG, dc-excited synchronous generator (DCESG), and permanent magnet synchronous generator (PMSG) have been reported as possible solutions. By introducing a full-scale power electronics converter and transformer to interface the power grid and the stator windings of the generator, the generated power from the wind turbine can be fully regulated.

Compared to the DFIG-based concept, the main advantages can be identified as the elimination of slip rings, simpler or even eliminated gearbox, and extended power and speed controllability, as well as better grid support capability. However, more stressed and expensive power electronics components as well as the higher power losses in the converter stage are the main drawbacks; this is the main reason why this concept is not always used in newly erected onshore wind turbines.

Because the power electronics converter in this concept needs to withstand all of the generated power at multiple megawatts, the 2L-VSC topology shown in Fig. 5 may suffer from high loss at this power level. Moreover, the cabling in the case of low voltage levels below 1 kV with high current is a design challenge. In order to cope with the growing power capacity, multicell converter configurations have been introduced (i.e., connect 2L-VSC cells in parallel or series). Fig. 7 shows the two most adopted multicell converter solutions, which have multiple 2L-VSCs connected in parallel both on the generator side and on the grid side. It is noted that the wire connections on the generator side and dc link could be different. This multicell converter configuration has the advantages of standard and proven low-voltage converter technologies as well as redundant and modular characteristics; therefore, it is the state-of-the-art solution for wind turbine products above 3 MW [21], [22].

C. Control of Power Electronics in WTSs

Controlling the power electronics in a state-of-the-art wind turbine involves both electrical and mechanical subsystems,

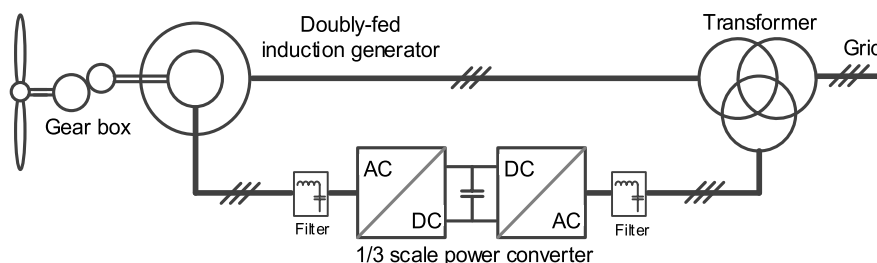

Fig. 4. Wind turbine concept with partial-scale power converter and a doubly fed induction generator.

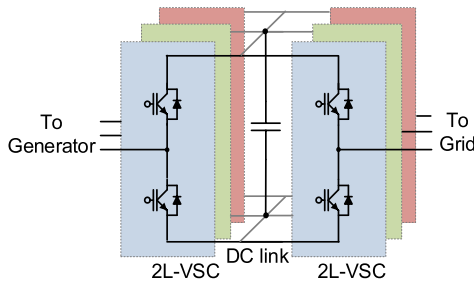

Fig. 5. Two-level voltage source converter topology for wind power application (2L-VSC).

as indicated in Fig. 8. A general control structure including blades, generator, and converter are illustrated. The applicable wind turbine concepts can be either a full-scale converter-based system with an induction generator (IG) or PMSG, or a partial-scale converter-based system with a DFIG.

The WTS can be controlled under three different layers, and fundamentally, the power flow in and out of the system must be managed. The input mechanical power from the turbine blades should be limited by controlling the mechanical parts such as the blade pitch angle (θ). Meanwhile, the electrical power injected to the power grid should be properly regulated according to the standards or commands issued by the distribution/transmission system operator (DSO/TSO). By introducing extra control functions, more advanced WTS features can be achieved, such as maximization of the turbine blade energy yield, ride-through operation under grid faults, and reactive and active power support in both normal and abnormal power grid operations. For example, the current in the generator will typically be managed by controlling the generator-side converter, and thereby the rotational speed of the rotor can be adjusted to achieve maximum power production according to the available wind energy. The basic control functions of the electrical system, like current regulation, dc bus stabilization, and grid synchronization, must be performed rapidly [23]–[27]. In some complicated cases, such as grid fault ride-through, coordinated controls of several subsystems, such as generator- and grid-side converters, braking choppers/crowbars, and pitch angle regulators are important [28]–[31]. Depending on the region, the TSO or DSO could impose extra control requirements on the WTS, such as limiting the rate of change of the output power and increasing the power inertia in order to reduce the impacts to grid and emulate the behaviors

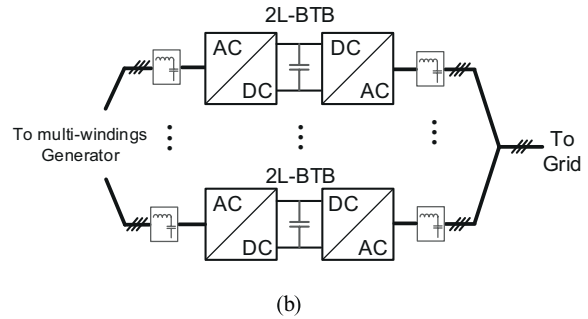
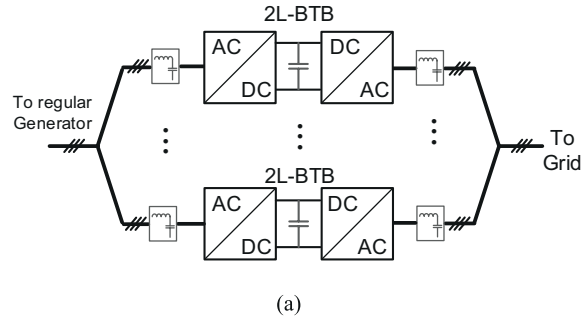

Fig. 7. Multicell converter solutions with paralleled 2L-VSC cells. (a) With regular generator. (b) With multi-winding generator.

of synchronous generators; reserving a certain capacity of active/reactive power in order to facilitate the grid support functions; taking a more active role in grid power quality management, such as damping low-frequency power oscillations or maintaining the local line voltage.

IV. POWER ELECTRONICS TECHNOLOGY FOR MULTIPLE WIND TURBINES AND WIND FARMS

Currently, most new installations of multimewatt turbines are part of wind farms, which aggregate the individual contributions into a power station. Traditionally, most wind farms are onshore based, but present plans and ongoing developments exist for large offshore deployments that would benefit from better wind conditions and are located away from land. The capacity of offshore wind farms can be up to 630 MW; for example, the Anholt wind farm of Denmark (commissioned in 2013) is illustrated in Fig. 9, and is rated at 400 MW and comprises 111 3.6-MW Siemens wind turbines. Other top-rated offshore wind farms include

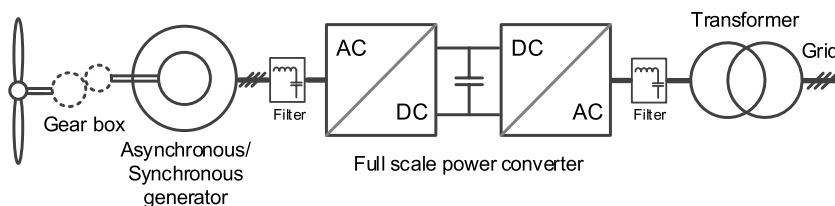

Fig. 6. Wind turbine concept with full-scale power converter.

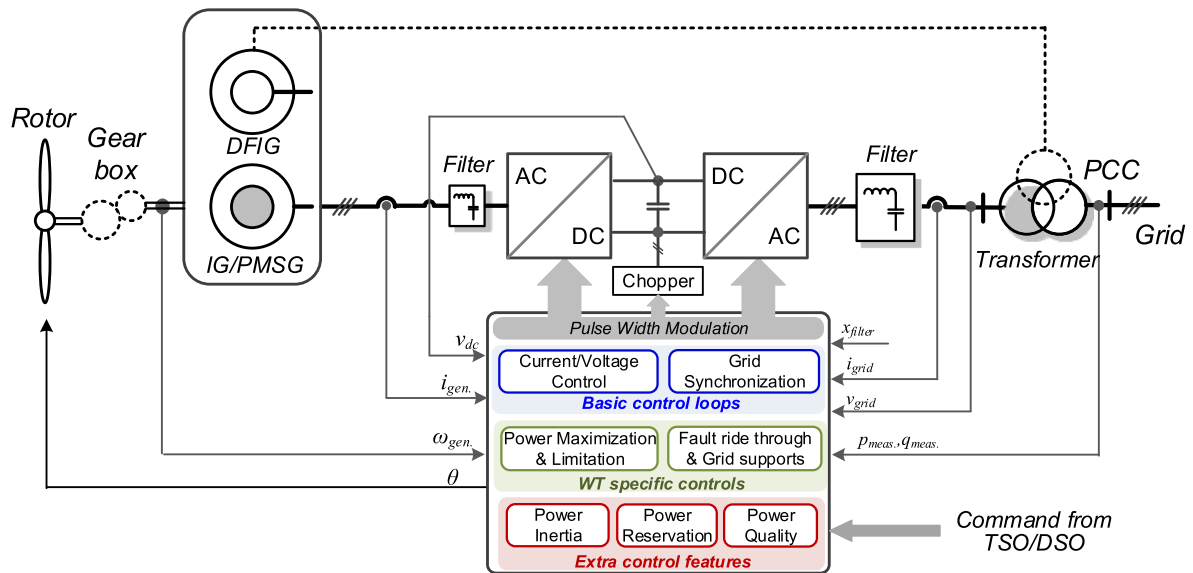

Fig. 8. Control structure for power electronics converter in WTS. (v_{dc} : dc-link voltage, i_{gen} : generator current, ω_{gen} : rotational speed of generator, θ : pitch angle of rotor blade, x_{filter} : filter impedance, i_{grid} : grid current, v_{grid} : grid voltage, p_{meas} : measured active power, q_{meas} : measured reactive power, PCC: point of common coupling).

the London Array of the United Kingdom, with 630-MW capacity (commissioned in 2012, largest in the world); Gemini of The Netherlands, with 600-MW capacity (under construction), and Global Tech I of Germany with 400-MW capacity (2015). The majority of these are located along the North Sea of Europe [32].

When considering the power generation at the wind-farm scale, on one hand, the high cost of energy requires the power transmission to be highly efficient, and on the other hand, the high power capacity requires the wind farm to be more active and able to provide support to the power grid. The power electronics is again an enabling technology for the wind farms in order to fulfill the growing demands. Some existing and future configurations of the wind farms employing power electronics are shown in Fig. 10.



Fig. 9. Denmark's largest off-shore wind farm of 400 MW installed at Anholt. Photo courtesy of Dong Energy Wind Power.

A typical wind farm equipped with DFIG-based WTSs is shown in Fig. 10(a). Such a configuration is in operation in Horns Rev offshore wind farm of Denmark with a capacity of 160 MW (installed in 2002), which is composed of 80 wind turbines from Vestas rated at 2 MW. Because of the limitation of reactive power capability, a reactive power compensator such as a static synchronous compensator (STATCOM) may be needed in this configuration in order to fully satisfy some emerging grid requirements. Similarly, Fig. 10(b) shows a wind farm configuration equipped with wind turbine concept based on a full-scale power converter. Compared to the DFIG-based wind farm, the reactive power capability in Fig. 10(b) is significantly extended, and the grid-side converter in each generation unit can provide the required reactive power locally. This configuration has become the dominant choice in the established offshore wind farms since 2010.

For power transmission of offshore wind farms, high-voltage direct current (HVDC) is an interesting solution because efficiency is improved and no reactive power compensators are needed [33], [34]. A typical solution for HVDC transmission of wind power is shown in Fig. 10(c), in which the medium-voltage alternating current (ac) from the wind turbine output is converted to high-voltage dc for transmission through a boost transformer and a high-voltage source rectifier. Half-controlled power semiconductors, such as thyristors, or fully controlled power semiconductors, such as insulated-gate bipolar transistors (IGBTs) connected in series, can be applied for power conversion at high voltage.

To achieve higher wind farm performance, a future configuration with HVDC transmission is shown in Fig. 10(d),

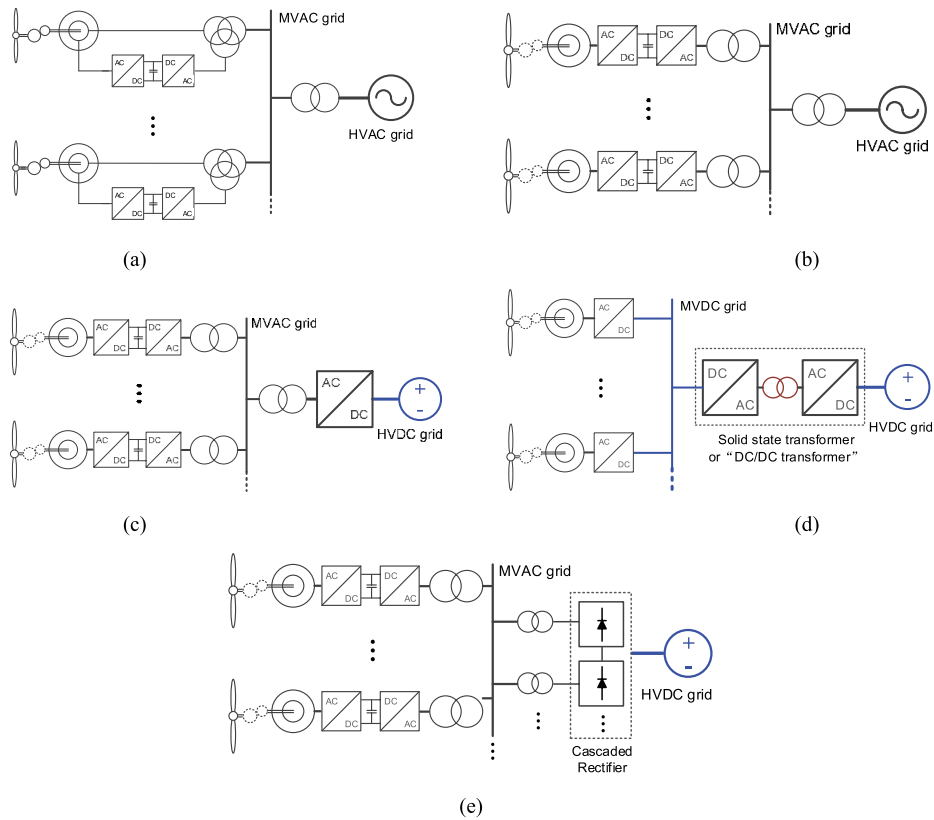

Fig. 10. Wind farm configurations with ac and dc power transmission. (a) Doubly fed induction generator system with ac grid. (b) Full-scale converter system with ac grid. (c) Full-scale converter system with VSC rectifier and transmission dc grid. (d) Full-scale converter system with both dc distribution and dc transmission grid. (e) Full-scale converter system with multiple diode rectifiers and dc transmission grid. (MVAC: medium voltage alternating current, MVDC: medium voltage direct current, HVAC: high voltage alternating current, HVDC: high voltage direct current).

where a solid-state dc transformer [35] is used to convert the low-/medium-voltage dc of the wind turbine outputs to medium-/high-voltage dc for power transmission. As a result, a completely full dc power delivery both in the distribution and transmission grid can be realized. It is claimed in [36] that the overall efficiency of the wind power delivery can be significantly improved compared to the configuration shown in Fig. 10(c), thanks to the reduction in converters and transformers.

In order to achieve more robust HVDC conversion and reduce the space/weight of the offshore platform, an HVDC concept for an offshore wind farm was recently proposed in [37] and [38], as shown in Fig. 10(e). In this configuration, the power control and power quality regulations are mainly performed by the distributed low-voltage wind power converters, and the rectifier is simply composed of diodes and has no control complexity. It is claimed that this solution will save 20% loss and 65% weight compared to the conventional VSC-based HVDC system at a scale of 200 MW. Moreover, the reduced number of components, easily scalable and redundant rectifier connections, and reliable packaging of power semiconductors make this solution

attractive for cost-effective HVDC transmission of offshore wind power.

It is noted that the feasibility and advantages/ disadvantages of the wind farm solutions shown in Fig. 10 still must be further evaluated. In addition to the factors of cost, efficiency, and functionality, other practical constraints, such as reliability, environmental impacts, power scalability, and robustness to extreme environments are crucial considerations for the construction of offshore wind farms.

In addition to the requirements for highly efficient power transmission, modern grid codes strictly regulate the behavior of the power delivered from wind turbines. Some of the requirements are difficult to achieve by individual wind turbine units. However, at the wind-farm level, more advanced grid support features can be better achieved by introducing special power electronics converters and controls.

Most grid codes demand the active power of the wind turbines to be flexibly regulated on the basis of grid frequency, as in a conventional synchronous machine-based power plant. However, the available active power of wind turbines should be based on the existing wind speeds, and in some cases it cannot match the power grid demands.

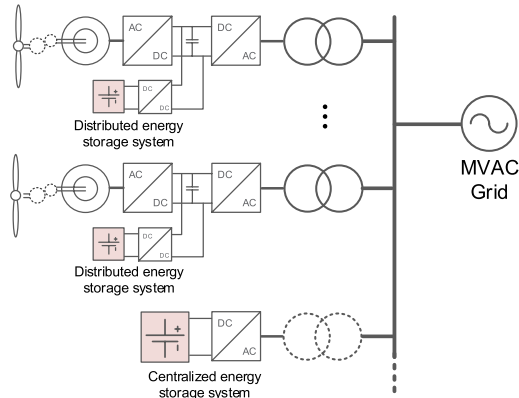

Fig. 11. Configurations of energy storage for wind power plants.

Consequently, some energy storage solutions may be needed for wind turbines and wind farms. The storage system can be configured locally for individual wind turbine units, or centrally in the wind farms, as shown in Fig. 11. The energy storage system could be configured in the form of a battery, supercapacitor, or even combined solutions, where the power electronics are an essential part in these storage systems to manage the power flow. Such wind farms equipped with energy storage will be ready to operate as the primary controller where enough energy is prestored and the wind power plant is approved by the TSO to enable this feature.

Similarly, in order to satisfy the requirements for reactive power support during grid voltage changes, reactive power compensators can be introduced at the wind farm level to reduce the burden and cost of individual wind turbine units. This is especially beneficial for the DFIG-based wind turbine concept, which has limited reactive power capability [39]–[41]. As shown in Fig. 12, these reactive power compensators, which could be STATCOMs or static VAR compensators (SVCs), can either be configured at the medium-voltage distribution grid, or directly configured at the high-voltage transmission grid with a transformer.

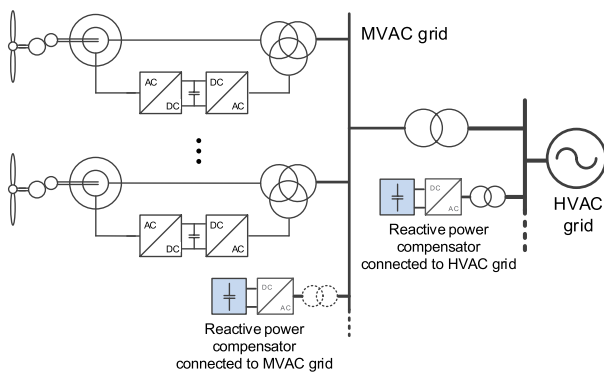

Fig. 12. Configurations of reactive power compensation for wind power plants.

Power electronics and control are essential parts in these reactive-power compensator systems.

V. TECHNOLOGY CHALLENGES FOR POWER ELECTRONICS IN WTSS

Along with capacity growth, there has been a dramatic evolution in the power electronics technology motivated by the continuous technology challenges in wind power applications. Some of these challenges are discussed in this section.

A. Low Levelized Cost of Energy

Cost is the most important factor that determines the feasibility of energy technologies being widely utilized. The competitive cost advantage is the main reason why wind power has shown significant growth in the last few decades compared to other renewable energy candidates. In order to benchmark the cost for different energy technologies, the index of levelized cost of energy (LCOE) is generally used [42]. LCOE represents the price at which the electricity is generated from an energy source over its lifetime. LCOE includes the major cost factors, such as research and development costs, initial investment, cost of fuel, capital cost, and operating and maintenance costs. LCOE can be defined in a simplified form as

$$LCOE = \frac{C_{Dev} + C_{Cap} + C_{O\&M}}{E_{Annual}} \quad (1)$$

where C_{Dev} represents the annualized initial development cost, C_{Cap} is the annualized capital cost, $C_{O\&M}$ is the annualized cost for operation and maintenance, and E_{Annual} is the annualized average energy production. From (1) it is clear that in order to reduce the cost of energy, one approach is to reduce the costs for development, capital, and operation and maintenance, and the other effective way is to extend the total energy production or increase the lifetime of the power generation system.

Fig. 13 lists the range and weighted average of LCOE for onshore wind power generation, offshore wind power generation, fossil-fuel-based power generation, as well as utility-scale solar PV power generation in 2014, without financial support [1], [2]. In 2014, the global weighted average LCOE of wind power generation was approximately 0.06 \$/kWh for onshore and 0.165 \$/kWh for offshore, thanks to the rapid advancements of technology and reliability. Onshore wind power generation is now actually cost competitive in several regions compared to fossil-fuel-based power generation, which has a weighted LCOE between 0.045 and 0.14 \$/kWh globally (excluding health and carbon emission costs). However, there is a significant margin for the price of offshore wind power technology to keep falling (claimed to be as low as 0.1 \$/kWh by 2025 [2]) because it is still in its infancy in terms of deployment. As a benchmark, the weighted average LCOE for utility-scale

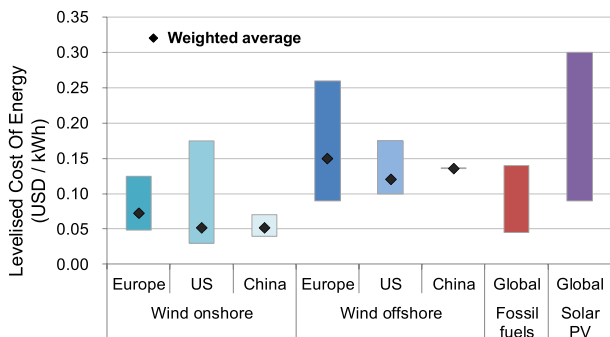

Fig. 13. Levelized cost of energy for wind power, fossil fuels, and solar PV in 2014 [1], [2].

solar PV power generation, which is between 0.09 and 0.3 \$/kWh depending on the region, is also indicated in Fig. 13.

As more power electronics with higher capacity are introduced to improve the performance of wind power generation, the cost of the power electronics is becoming important in WTSs. There are some cost considerations that impose challenges for the design and the selection of power electronics technologies. For example, the need for high-power and full-scale power conversion will increase the cost of power semiconductors, passive components, and the corresponding cooling systems; more efficient circuits and components are required to reduce the losses and balance the budget. Additionally, the cable connections between the nacelle and the tower base, ranging from dozens to hundreds of meters, demand a higher voltage level in the power conversion stage of power electronics in order to reduce the cable losses and cable weight. On the other hand, because of the limited space in the nacelle or tower of wind turbines, the power converters must be designed at higher power density, which may lead to extra cost for insulation materials and compact structures as the voltage level increases. Furthermore, the remote locations of the wind turbines will increase the cost for installation and maintenance, thereby increasing the demand for high reliability, modularity, and redundant capabilities of the power electronics converters.

B. Complex Mission Profiles

The complicated behavior of wind speed can be grouped into several wind classes defined by three factors: the average annual wind speed, the speed of the extreme wind gust that may occur over 50 years, and how much turbulence exists at the wind site. According to the IEC standard [43], there are three types of wind-speed variations, called class I (high), class II (medium), and class III (low), defined as annual average speeds of 10, 8.5, and 7.5 m/s, respectively. The distribution of the wind speed under different wind classes is shown in Fig. 14, where the Weibull function is used to describe the distribution characteristics. A one-year wind-speed profile is shown in Fig. 15 with 3-h averages

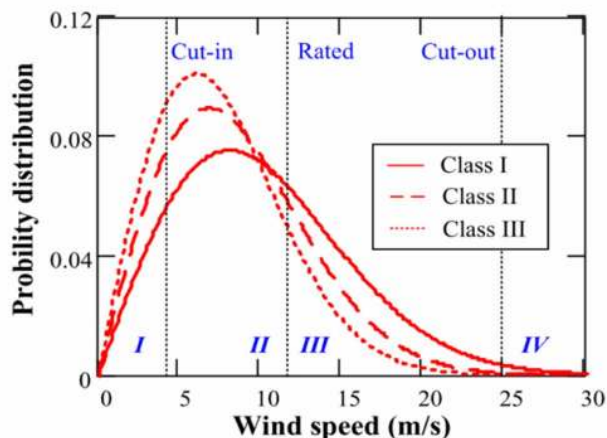

Fig. 14. Distributions of the wind speeds under different wind classes and the operation of wind turbines (region I: no power generation below cut-in wind speed; region II: maximum power point tracking generation; region III: constant power generation; region IV: no power generation above cut-out wind speed).

at 80-m hub height, which was collected from the wind farm in Thyborøn, Denmark [44]. The shown wind speed belongs to the IEC wind class I (high) with an average wind speed of 8.5–10 m/s, and significant wind-speed variations can be identified. It should be noted that the locations of wind turbines experiencing different wind classes will result in various operating strategies as well as the selection of the rotor size.

In WTSs, the generator is energized by the power electronics converter to regulate the electromagnetic torque, not only for maximizing the extracted power from the blades, but also for balancing the energy flow in the case of dynamics due to an inertia mismatch between the mechanical and electrical power. As a result, complicated wind-speed behavior will be somehow transferred to the electrical power in the converter, and thus stress the power electronics components. The complex loadings and transients will impose challenges for the selection of converter topologies and devices, as well as the design of the controls and the cooling system. Moreover, as reported in [45], the fluctuating

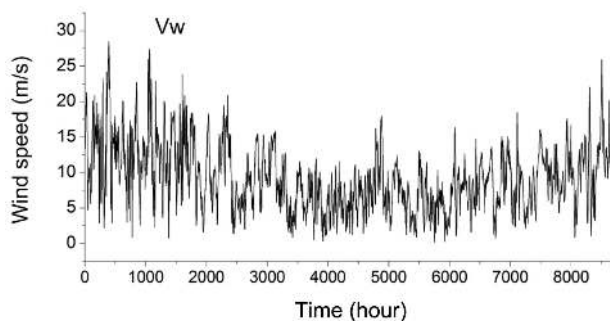

Fig. 15. One-year wind-speed (V_w) variations at a wind farm of Thyborøn, Denmark (80-m height, 3-h averaged).

operating points may excite some stability issues of the wind farm with frequency oscillation close to the fundamental frequency, and other normal WTSs connected in the wind farm could thereby be disturbed.

There are some other challenges related to the mission profiles (i.e., operating conditions) of wind turbines: Because of the fast-growing power capacity, the voltage level of the power conversion may need to be scaled up to facilitate the power transmission and reduce loss. The output voltage of the WTS is typically set at 30 kV, but is recently seen to be raised above 60 kV; in this case, a bulky transformer is required at the multimegawatt power level. Finally, because of the inertia mismatch between the mechanical power and electrical power, energy storage and balancing mechanisms are important considerations and may result in extra system cost and control complexity.

C. Strict Grid Codes

The fluctuating and unpredictable features of wind energy are not preferred for grid operation. Most countries have issued strict requirements for the behavior of wind turbines, also known as “grid codes” [46]–[49]. Essentially, the grid codes are always attempting to make WTSs act like conventional power plants from the point of view of grid operation, i.e., the WTS should wisely manage the delivered active and reactive power according to demand, and provide frequency and voltage support when they are needed. Some examples of the state-of-the-art grid requirements for WTS are discussed in the following; they are specified either for the individual wind turbine or for the whole wind farm.

Individual wind turbines must be able to control active power at the point of common coupling (PCC) to the grid. Normally, active power must be adjusted according grid frequency, so that grid frequency can somehow be maintained. As an example, the demands of frequency support in the Danish grid codes are shown in Fig. 16(a), where the active power should be decreased when the frequency rises above 48.7 or 50.15 Hz, depending on the power reservation strategy [47]. Similarly, the reactive power delivered by the WTS must be regulated in a certain range. Fig. 16(b) shows the range of the reactive power reserved by the WTS under different active power outputs [48]. In addition, the TSO normally specifies the delivered reactive power of the WTS according to the grid voltage levels. These demands result in extra reserved capacity and higher cost when practically designing the power converter as well as the wind farm. It is noted that the regulation of reactive power should be performed slowly under a time constant of minutes [47].

In addition to the demands under normal power grid operation, increasing numbers of TSOs have issued strict grid support requirements for WTSs under grid fault conditions. Fig. 16(c) shows various amplitudes of grid voltage dips against the allowable disturbance time of faults defined for a wind farm. Fig. 16(c) is also known as the low-voltage ride-through

(LVRT) requirements. It is becoming an emerging need that the WTS should provide reactive power (up to 100% current capacity of the converter) to contribute to the recovery of grid voltage. Fig. 16(d) defines the required amount of reactive current against the amplitude of grid voltage by the German [48] and Danish grid codes [47]. This demand is relatively difficult to meet by wind farms equipped with DFIG-based wind turbines, and auxiliary power quality units such as STATCOMs may probably be introduced to assist the WTS in meeting this important requirement.

The demanding codes for grid support by WTSs on one hand have increased the cost of energy, but on the other hand have also made wind energy more suitable to be utilized and integrated into the power grid. It is predicted that stricter grid codes in more countries will keep pushing forward the evolution of power electronic technologies. Table 2 compares the grid integration performance of the conventional power plant, WTSs in the past without (or with few) power electronics, and modern WTSs equipped with power electronics converters compliant with grid codes. It can be concluded that by introducing more advanced power electronics, controls, and grid regulations, the start-of-the-art WTS can more or less emulate the behavior of conventional power plants, making wind power technology suitable for integration into the power grid.

D. Growing Reliability Requirements

Because of the fast growth in power capacity, the WTS failures may have adverse impacts on grid stability, and reliability performance is now especially emphasized for the WTS in view of the high costs of repairs as well as the loss of production. Today, it is generally required that the power electronics used for wind turbines should have at least a 20-year lifetime, which is at the same level of requirements for aircraft applications in terms of running hours. However, according to some studies, it was discovered that the reliability performance of wind turbines, including the power electronics parts, still have margin for improvement, especially for larger wind turbines at the multimegawatt scale [50]–[51]. This is because they are complicated systems that comprise a large number of components stressed under tough mission profiles [52]–[55].

Triggered by the complex mission profiles, the thermal cycles or dynamic temperature variations are one of the main causes of failure for the power electronic components [56]–[58]. The relationship between the characteristics of thermal cycles and the lifetime of power semiconductors has been extensively tested and revealed in the last two decades. Generally, it was found that the lifetime of devices will be shorter under thermal cycles with higher fluctuation amplitudes and mean values. As mentioned previously, the complex mission profiles of the converter in wind power applications will indicate adverse loading conditions on the components from the viewpoint of reliability performance.

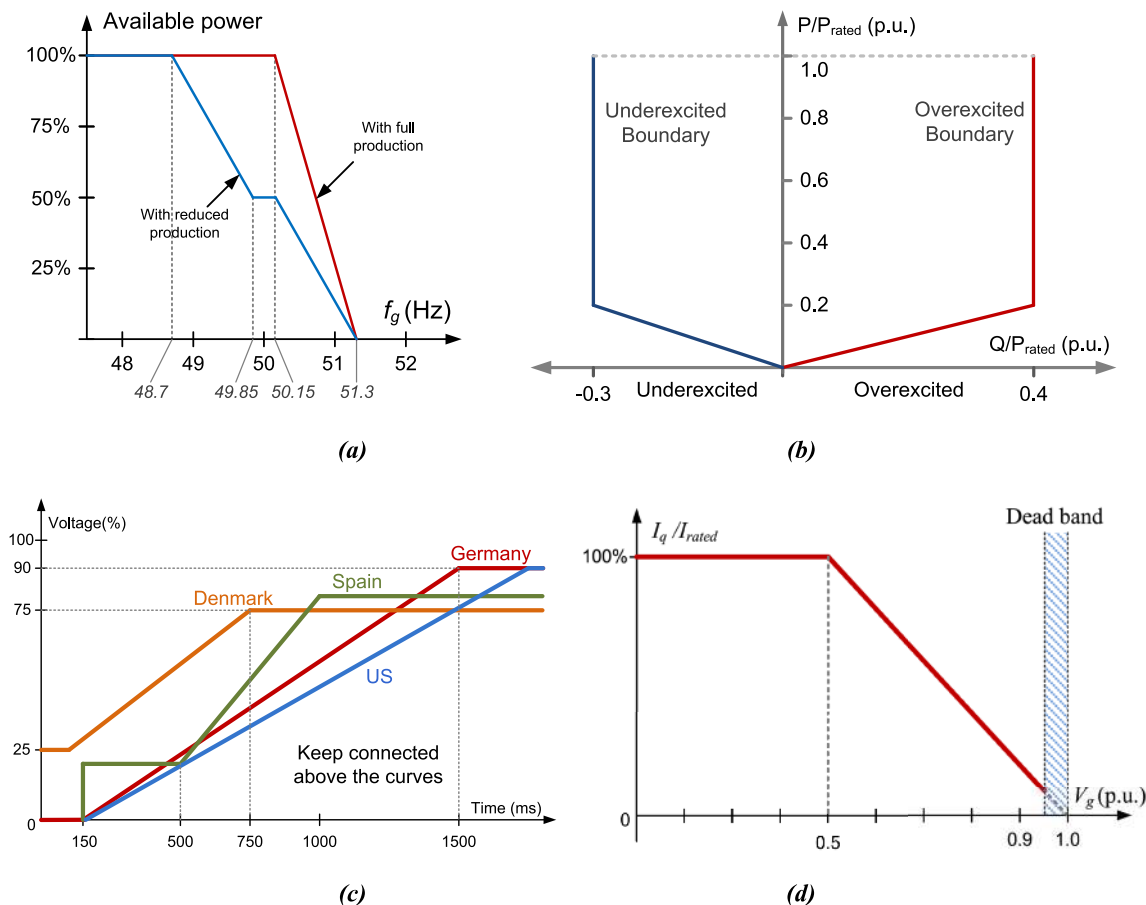

Fig. 16. Typical grid codes for the WTS. (a) Frequency control profiles for the wind turbines connected to the Danish grid [47]. (b) Reserved reactive power capability under different generating powers for a wind farm specified by the German grid codes [48]. (c) Low voltage ride-through capability of wind turbines by different countries [46]. (d) Reactive current requirements for a wind farm during grid sags by the German and Danish grid code [48], [49].

Table 2 Comparison of Grid Integration Performances Between Conventional Power Plant and Wind Turbine Plant, the More “+” the Better, “0” Means Moderate, “-” Means No Such Ability, PEC Means Power Electronics Converter

Grid integration Features	Conventional power plant	WTS in the past (without/few PEC)	WTS nowadays/future (With PEC)
Active power control	+	0	+
Reactive power control	+	0 / -	++
Short circuit capability	++	+	++
Voltage backup	++	-	+
Power inertia	++	-	+
Frequency control	++	-	++
Black-start capability	+	-	+

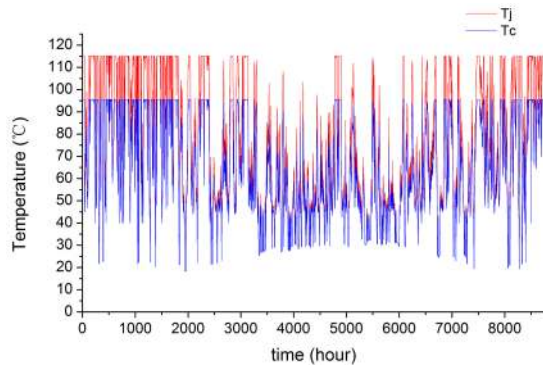

Fig. 17. One-year thermal profile under the given wind-speed profile in Fig. 15 (junction temperature T_j and case temperature T_c of the IGBT, time step of 3 h) [44].

An example as demonstrated in [44] is shown in Fig. 17, which converts the wind-speed profile of Fig. 15 into the thermal stress of the power semiconductor devices in a full-scale wind power converter. Many thermal cycles ranging from 15 to 90 K are identified, and they may lead to an unsatisfactory lifetime much less than 20 years by using some lifetime models of the power semiconductor devices [58].

In addition to the long-term thermal cycles caused by wind-speed variation, there are other types of thermal cycles, which dominate at much smaller time scales and are mainly caused by the alternating of the current and the control behavior of the converter. An example is conducted with a DFIG-based concept and a full-scale converter-based concept for a 2-MW wind turbine. The rotational speed ranges of these two types of wind turbines are quite different, leading to different fundamental frequencies and current in the generator-side converter. The thermal cycling of the power devices within 0.2 s for these two types of wind turbines is shown in Fig. 18. It can be seen that in the DFIG-based system, the converter

could suffer from a higher amplitude of thermal cycles compared to the full-scale power converter-based system; this means worse loading conditions for the device with respect to reliability performance [59].

In order to map the reliability and establish a more complete thermal behavior of the power devices according to the mission profile of the wind power converter, new modeling and testing approaches must be introduced. A potential method is demonstrated in [44], similar to lenses with different focal lengths used in photography. The loading analysis and modeling of the wind power converter are separated under several time constants with different modeling techniques or tools.

VI. FUTURE POWER ELECTRONICS TECHNOLOGY FOR WIND TURBINES

Most of the installed wind turbines today are based on power conversion at low voltage levels (i.e., below 690 Vrms line-to-line ac). In order to handle the fast-growing capacity of wind turbines and wind farms, new power electronics technologies, which can realize more efficient and reliable power conversion, are expected in the near future to achieve power conversion at higher voltage levels (1–10 kV). The major changes are focused in the converter topology and semiconductor devices.

With the ability to convert higher voltage and power, multilevel converters may become the preferred choice in full-scale power-converter-based WTSs [60]–[63]. The three-level active/non-active neutral-point diode clamped (3L-NPC/ANPC) converter is one of the most commercialized multilevel topologies on the market, and it could be utilized in wind power applications, as shown in Fig. 19. The 3L-NPC/ANPC converter achieves one more voltage level and less dv/dt stress compared to 2L-VSC; thus it is possible to realize medium-voltage power

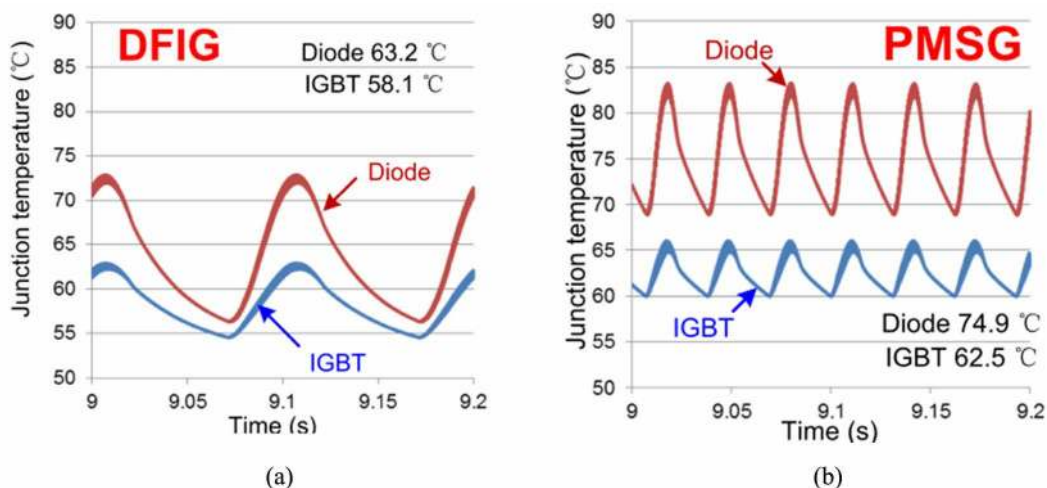

Fig. 18. Junction temperature of power devices of a 2-MW wind power converter with different generators (DFIG: doubly fed induction generator; PMSG: permanent magnet synchronous generator) [59]. (a) DFIG rotor side. (b) PMSG generator side.

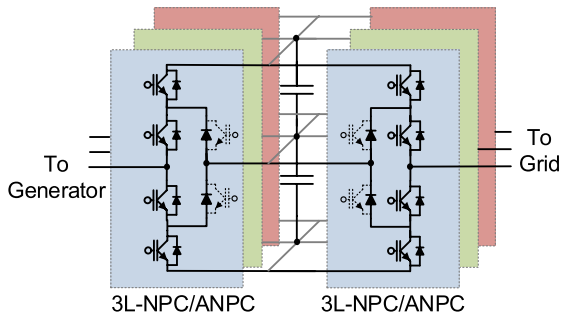

Fig. 19. Three-level (active) neutral point clamped converter for wind turbine (3L-NPC/ANPC).

conversion under lower current, smaller filter size, and fewer converters connected in parallel.

An advanced converter configuration that shares a similar idea with the next-generation traction converters, the European UNIFLEX-PM project, as well as the U.S. FREEDM project [64]–[67], could be another interesting solution for future WTSs. As demonstrated in Fig. 20, it is based on a solid-state dc transformer composed of multiple dual active bridge (DAB) building blocks with galvanic isolation. The size of the transformer inside the DAB can be limited in both weight and volume thanks to the medium-frequency excitation. Moreover, the solid-state dc transformer can be directly connected to the medium-voltage dc distribution grid in the future, or the ac distribution grid (10 kV–20 kV) with a medium-voltage dc/ac converter. Moreover, the high controllability of the solid-state dc transformer by the use of power electronics could bring some interesting features such as power routing and grid support for the future “smarter” grid. This configuration would become attractive if it can be placed in the nacelle, where the bulky line-frequency transformer at the multi-megawatt scale can be replaced by more compact and flexibly configured power semiconductor devices, bringing a promising enhancement of overall power density, modularity, and redundancy of the converter system.

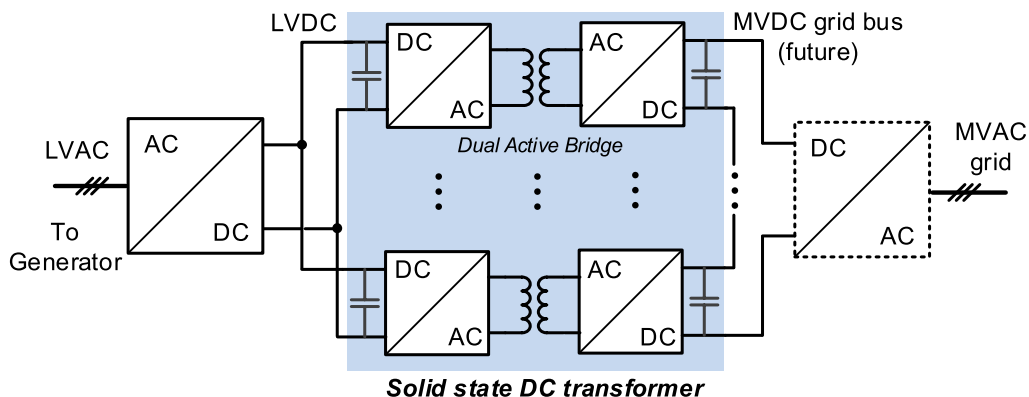

Fig. 20. Converter solution with solid-state dc transformer for wind power application.

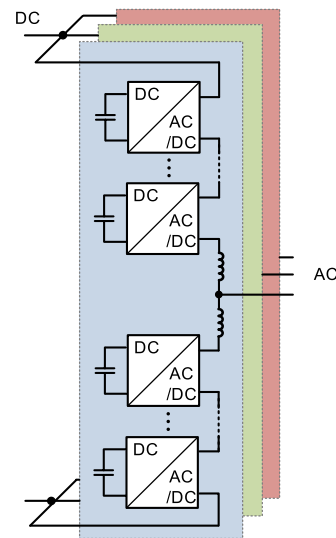

Fig. 21. Modular multilevel converters for power distribution/transmission of wind turbines.

Similarly, an emerging converter used for HVDC transmission [68], [69], called the modular multilevel converter (MMC), could be used in future wind power applications for power distribution or transmission, as shown in Fig. 21. One advantage of this configuration is the easily scalable capability of voltage and power; therefore, it can achieve a wide range of power conversion at the kilovolts level with high redundancy and modularity. Moreover, the ac filter can be eliminated because of the significantly increased voltage levels [69]. This feature is especially beneficial at high voltage and high power conversion. The MMC is also an ideal solution to interface the MVDC and MVAC grids in the configuration shown in Fig. 20.

It is worth mentioning that the modular converter configurations shown in Figs. 20 and 21 both have good redundancy and fault-tolerant ability, which contribute to higher reliability performance. On the other hand, these configurations have significantly increased component counts, which would

compromise the system reliability and efficiency, and the cost could be increased. Because the technologies for power semiconductor devices are developing rapidly, the overall merits and disadvantages of these modular converters used in wind power applications still must be carefully evaluated.

The power semiconductor devices are also key technologies and major concerns for wind power converters, because they are related to many critical performance measures, such as cost, power density, efficiency, reliability, and modularity. The silicon-based semiconductor technologies seen in wind power applications include module-packaged IGBTs, press-pack packaged IGBTs, and press-pack packaged integrated gate commutated thyristors (IGCTs) [70]–[72]. In the last decade, there has been rapid development of wide-bandgap (WBG) devices based on silicon carbide (SiC) or gallium nitride (GaN); SiC devices that have higher voltage/power capability are more promising choices in wind power applications. The major SiC devices are in the form of module packaging metal–oxide–semiconductor field-effect transistors (MOSFETs) as well as diodes for high power application.

The key features of the four types of power semiconductor devices are generally compared in Table 3. The module packaging technology of IGBT has a longer track record of applications and benefits from fewer mounting restrictions. However, they may suffer from larger thermal resistance and lower power density, and might have higher failure rates [73]. Interesting trends in improving the packaging of IGBT modules include introducing pressure contacts to eliminate the base plate, sinter technology to avoid chip soldering, and copper bond wires to reduce the coefficient of thermal expansion—all leading to increased lifetime, as reported in [74]. However, cost issues are always critical topics when commercializing these new technologies.

Press-pack packaging technology improves the connection of chips by direct press-pack contacting of the joints, leading to improved reliability, higher power density (easier stacking), and better cooling capability. However, IGCTs have not yet been heavily adopted in wind power applications because of their relatively high cost. As the power capacity of wind turbines grows even up to 10 MW, press-pack packaging technology is expected to become a more interesting solution for future WTSS, when medium-voltage-level conversion will become the preferred choice.

In addition to silicon-based power devices, SiC devices, which have better switching characteristics and higher voltage-blocking capability, are a promising technology for future wind power systems [75], [76]. Although the existing current ratings of SiC devices are still not high enough for wind power conversion, these new devices do show a great potential to simplify the topology of power conversion at the medium- and high-voltage levels. They can also be used in some future converter structures that consist of parallel or cascaded converter building blocks.

VII. CONCLUSION

The individual power ratings and installations of wind turbines have been significantly increased over recent decades, such that wind energy now plays an important and growing role in power systems. A main driving factor is represented by the continuous need for sustainable and renewable energy at competitive prices.

This review of state-of-the-art solutions indicates that power electronic technologies, including associated controls, have significantly improved the operation and

Table 3 Power Semiconductor Devices and Modules for Wind Power Application

Performances	IGBT module	IGBT Press-pack	IGCT Press-pack	SiC MOSFET module
Power Density	Low	High	High	Low
Reliability	Moderate	High	High	Unknown
Cost	Moderate	High	High	High
Failure mode	Open circuit	Short circuit	Short circuit	Open circuit
Insulation to heat sink	+	-	-	+
Snubber	-	-	+	-
Thermal resistance	Large	Small	Small	Moderate
Cost	Moderate	High	High	High
Gate driver	Moderate	Moderate	Large	Small
Typical voltage ratings	1.7 kV - 6.5 kV	2.5 kV / 4.5 kV	4.5 kV / 6.5 kV	1.2 kV / 1.7 kV / 10 kV
Max. current ratings	1.5 kV - 750 A	2.3 kA / 2.4 kA	3.6 kA / 3.8 kA	300 A / 200 A / 10 A

performance of WTSs. Through proper selection and configuration, controls, and grid regulations, it is now possible for WTSs and wind farms to act like conventional power plants and actively contribute to frequency and voltage control in the power grid.

These capabilities create opportunities for continued large-scale deployment of wind turbines and wind farms.

Furthermore, driven by the need to reduce the cost of energy and enhance the performance of energy conversion, there are still many new possibilities for the advancement of power electronics technologies, including the development and application of new topologies and power devices, increase in reliability, and the incorporation of energy storage and more power system control capabilities. ■

REFERENCES

- [1] REN21. (Jan. 2017). *Renewables 2016: Global Status Report (GSR)*. [Online]. Available: <http://www.ren21.net/>
- [2] IRENA. (Jan. 2015). *Renewable Power Generation Costs in 2014*. [Online]. Available: <http://www.irena.org/>
- [3] GWEC. (Feb. 2017). *Global Wind Statistics 2016*. [Online]. Available: www.gwec.net
- [4] M. Liserre, R. Cardenas, M. Molinas, and J. Rodriguez, "Overview of multi-MW wind turbines and wind parks," *IEEE Trans. Ind. Electron.*, vol. 58, no. 4, pp. 1081–1095, Apr. 2011.
- [5] Z. Chen, J. M. Guerrero, and F. Blaabjerg, "A review of the state of the art of power electronics for wind turbines," *IEEE Trans. Power Electron.*, vol. 24, no. 8, pp. 1859–1875, Aug. 2009.
- [6] F. Blaabjerg, Z. Chen, and S. B. Kjaer, "Power electronics as efficient interface in dispersed power generation systems," *IEEE Trans. Power Electron.*, vol. 19, no. 5, pp. 1184–1194, Sep. 2004.
- [7] A. D. Hansen, F. Iov, F. Blaabjerg, and L. H. Hansen, "Review of contemporary wind turbine concepts and their market penetration," *J. Wind Eng.*, vol. 28, no. 3, pp. 247–263, 2004.
- [8] M. P. Kazmierkowski, R. Krishnan, and F. Blaabjerg, Eds., *Control in Power Electronics: Selected Problems*. San Diego, CA, USA: Academic, 2002.
- [9] F. Blaabjerg, M. Liserre, and K. Ma, "Power electronics converters for wind turbine systems," *IEEE Trans. Ind. Appl.*, vol. 48, no. 2, pp. 708–719, Mar./Apr. 2012.
- [10] F. Blaabjerg and K. Ma, "Future on power electronics for wind turbine systems," *IEEE J. Emerg. Sel. Topics Power Electron.*, vol. 1, no. 3, pp. 139–152, Sep. 2013.
- [11] C. Morris. (2013). "Denmark surpasses 100 percent wind power." Energy Transition.de, accessed on Dec. 2014. [Online]. Available: <http://energytransition.de/2013/11/denmark-surpasses-100-percent-wind-power/>
- [12] (Jan. 2017). Website of MHI Vestas Offshore Wind. [Online]. Available: <http://www.mhivestasoffshore.com/>
- [13] UpWind Project. (Mar. 2011). *Design Limits and Solutions for Very Large Wind Turbines*. [Online]. Available: http://www.ewea.org/fileadmin/ewea_documents/documents/upwind/21895_UpWind_Report_low_web.pdf
- [14] B. Wu, Y. Lang, N. Zargari, and S. Kouro, *Power Conversion and Control of Wind Energy Systems*. Hoboken, NJ, USA: Wiley, 2011.
- [15] R. Pena, J. C. Clare, and G. M. Asher, "Doubly fed induction generator using back-to-back PWM converters and its application to variable-speed wind-energy generation," *Electr. Power Appl.*, vol. 143, no. 3, pp. 231–241, 1996.
- [16] S. Müller, M. Deicke, and R. W. De Doncker, "Doubly fed induction generator systems for wind turbines," *IEEE Ind. Appl. Mag.*, vol. 8, no. 3, pp. 26–33, May/Jun. 2002.
- [17] D. Xiang, L. Ran, P. J. Tavner, and S. Yang, "Control of a doubly fed induction generator in a wind turbine during grid fault ride-through," *IEEE Trans. Energy Convers.*, vol. 21, no. 3, pp. 652–662, Sep. 2006.
- [18] F. K. A. Lima, A. Luna, P. Rodriguez, E. H. Watanabe, and F. Blaabjerg, "Rotor voltage dynamics in the doubly fed induction generator during grid faults," *IEEE Trans. Power Electron.*, vol. 25, no. 1, pp. 118–130, Jan. 2010.
- [19] W. Chen, D. Xu, N. Zhu, M. Chen, and F. Blaabjerg, "Control of doubly-fed induction generator to ride-through recurring grid faults," *IEEE Trans. Power Electron.*, vol. 31, no. 7, pp. 4831–4846, Jul. 2016.
- [20] D. Santos-Martin, J. L. Rodriguez-Amenedo, and S. Arnaltes, "Providing ride-through capability to a doubly fed induction generator under unbalanced voltage dips," *IEEE Trans. Power Electron.*, vol. 24, no. 7, pp. 1747–1757, Jul. 2009.
- [21] B. Andresen and J. Birk, "A high power density converter system for the Gamesa G10x 4,5 MW wind turbine," in *Proc. EPE*, Sep. 2007, pp. 1–7.
- [22] R. Jones and P. Waite, "Optimised power converter for multi-MW direct drive permanent magnet wind turbines," in *Proc. EPE*, 2011, pp. 1–10.
- [23] X. Yuan, F. Wang, D. Boroyevich, Y. Li, and R. Burgos, "DC-link voltage control of a full power converter for wind generator operating in weak-grid systems," *IEEE Trans. Power Electron.*, vol. 24, no. 9, pp. 2178–2192, Sep. 2009.
- [24] P. Rodriguez, A. Timbus, R. Teodorescu, M. Liserre, and F. Blaabjerg, "Reactive power control for improving wind turbine system behavior under grid faults," *IEEE Trans. Power Electron.*, vol. 24, no. 7, pp. 1798–1801, Jul. 2009.
- [25] A. Timbus, M. Liserre, R. Teodorescu, P. Rodriguez, and F. Blaabjerg, "Evaluation of current controllers for distributed power generation systems," *IEEE Trans. Power Electron.*, vol. 24, no. 3, pp. 654–664, Mar. 2009.
- [26] M. Liserre, F. Blaabjerg, and S. Hansen, "Design and control of an LCL-filter-based three-phase active rectifier," *IEEE Trans. Ind. Appl.*, vol. 41, no. 5, pp. 1281–1291, Sep./Oct. 2005.
- [27] P. Rodriguez, A. V. Timbus, R. Teodorescu, M. Liserre, and F. Blaabjerg, "Flexible active power control of distributed power generation systems during grid faults," *IEEE Trans. Ind. Electron.*, vol. 54, no. 5, pp. 2583–2592, Oct. 2007.
- [28] S. M. Mueyeen, R. Takahashi, T. Murata, and J. Tamura, "A variable speed wind turbine control strategy to meet wind farm grid code requirements," *IEEE Trans. Power Electron.*, vol. 25, no. 1, pp. 331–340, Feb. 2010.
- [29] R. Cardenas, R. Peña, S. Alepuz, and G. Asher, "Overview of control systems for the operation of DFIGs in wind energy applications," *IEEE Trans. Ind. Electron.*, vol. 60, no. 7, pp. 2776–2798, Jul. 2013.
- [30] S. Alepuz *et al.*, "Control strategies based on symmetrical components for grid-connected converters under voltage dips," *IEEE Trans. Ind. Electron.*, vol. 56, no. 6, pp. 2162–2173, Jun. 2009.
- [31] L. Yang, Z. Xu, J. Østergaard, Z. Y. Dong, and K. P. Wong, "Advanced control strategy of DFIG wind turbines for power system fault ride through," *IEEE Trans. Power Syst.*, vol. 27, no. 2, pp. 713–722, May 2012.
- [32] (2017). *List of Offshore Wind Farms*. [Online]. Available: https://en.wikipedia.org/wiki/List_of_offshore_wind_farms
- [33] A. Prasai, J.-S. Yim, D. Divan, A. Bendre, and S.-K. Sul, "A new architecture for offshore wind farms," *IEEE Trans. Power Electron.*, vol. 23, no. 3, pp. 1198–1204, May 2008.
- [34] F. Iov, P. Sørensen, A. D. Hansen, and F. Blaabjerg, "Modelling, analysis and control of DC-connected wind farms to grid," *Int. Rev. Electr. Eng.*, p. 10, Feb. 2006.
- [35] S. P. Engel, N. Soltan, H. Stagge, and R. W. De Doncker, "Dynamic and balanced control of three-phase high-power dual-active bridge DC–DC converters in DC-grid applications," *IEEE Trans. Power Electron.*, vol. 28, no. 4, pp. 1880–1889, Apr. 2012.
- [36] C. Meyer, M. Hoing, A. Peterson, and R. W. De Doncker, "Control and design of DC grids for offshore wind farms," *IEEE Trans. Ind. Appl.*, vol. 43, no. 6, pp. 1475–1482, Nov./Dec. 2007.
- [37] R. Blasco-Gimenez, S. Añó-Villalba, J. Rodríguez-D'Herlée, F. Morant, and S. Bernal-Perez, "Distributed voltage and frequency control of offshore wind farms connected with a diode-based HVdc link," *IEEE Trans. Power Electron.*, vol. 25, no. 12, pp. 3015–3095, Dec. 2010.
- [38] P. Menke *et al.*, "Latest DC grid access using diode rectifier units (DRU)," in *Proc. Siemens AG, Wind Integration Workshop*, Brussels, Belgium, Oct. 2015.
- [39] W. Qiao, G. K. Venayagamoorthy, and R. G. Harley, "Real-time implementation of a STATCOM on a wind farm equipped with doubly fed induction generators," *IEEE Trans. Ind. Appl.*, vol. 45, no. 1, pp. 98–107, Jan. 2009.
- [40] A. Arulampalam, M. Barnes, N. Jenkins, and J. B. Ekanayake, "Power quality and stability improvement of a wind farm using STATCOM supported with hybrid battery energy storage," *IEE Proc. Gen., Transm. Distrib.*, vol. 153, no. 6, pp. 701–710, 2006.
- [41] M. Molinas, J. A. Suul, and T. Undeland, "Low voltage ride through of wind farms with cage generators: STATCOM versus SVC," *IEEE Trans. Power Electron.*, vol. 23, no. 3, pp. 1104–1117, May 2008.
- [42] Wikipedia. (2017). *Cost of Electricity by Source*. [Online]. Available: http://en.wikipedia.org/wiki/Cost_of_electricity_by_source

- [43] *Wind Turbines—Part I: Design Requirements IEC 61400-1*, 3rd ed.
- [44] K. Ma, M. Liserre, F. Blaabjerg, and T. Kerekes, "Thermal loading and lifetime estimation for power device considering mission profiles in wind power converter," *IEEE Trans. Power Electron.*, vol. 30, no. 2, pp. 590–602, Feb. 2015.
- [45] M. Tsili and S. Papathanassiou, "A review of grid code technical requirements for wind farms," *IET Renew. Power Generat.*, vol. 3, no. 3, pp. 308–332, Sep. 2009.
- [46] *Energinet—Wind Turbines Connected to Grids With Voltages below 100 KV*, Jan. 2003.
- [47] *Energinet—Technical Regulation 3.2.5 for Wind Power Plants With a Power Output Greater Than 11 KW*, Sep. 2010.
- [48] Tennet TSO GmbH, *Grid Code—High and extra high voltage*, Dec. 2012.
- [49] Tennet TSO GmbH, *Requirements for Offshore Grid Connections in the Grid of Tennet TSO GmbH*, Dec. 2012.
- [50] S. Faulstich, P. Lyding, B. Hahn, and P. Tavner, "Reliability of offshore turbines—identifying the risk by onshore experience," in *Proc. Eur. Offshore Wind*, Stockholm, Sweden, 2009.
- [51] B. Hahn, M. Drstewitz, and K. Rohrig, "Reliability of wind turbines—Experience of 15 years with 1500 WTs," in *Wind Energy*. Berlin, Germany: Springer-Verlag, 2007.
- [52] E. Wolfgang, L. Amigues, N. Seliger, and G. Lugert, "Building-in reliability into power electronics systems," in *Proc. World Electron. Packag. Syst. Integr.*, 2005, pp. 246–252.
- [53] D. Hirschmann, D. Tissen, S. Schroder, and R. W. de Doncker, "Inverter design for hybrid electrical vehicles considering mission profiles," in *Proc. IEEE Conf. Veh. Power Propuls.*, vols. 7–9, Sep. 2005, pp. 1–6.
- [54] E. Wolfgang, "Examples for failures in power electronics systems," presented at the ECPE Tuts. Rel. Power Electron. Syst., Nuremberg, Germany, Apr. 2007.
- [55] S. Yang, A. Bryant, P. Mawby, D. Xiang, L. Ran, and P. Tavner, "An industry-based survey of reliability in power electronic converters," *IEEE Trans. Ind. Appl.*, vol. 47, no. 3, pp. 1441–1451, May/June. 2011.
- [56] C. Busca et al., "An overview of the reliability prediction related aspects of high power IGBTs in wind power applications," *Microelectron. Rel.*, vol. 51, nos. 9–11, pp. 1903–1907, 2011.
- [57] A. Wintrich, U. Nicolai, and T. Reimann, *Semikron Application Manual*. 2011, p. 128.
- [58] J. Berner, "Load-cycling capability of HiPakIGBT modules," ABB Group, Zürich, Switzerland, Appl. Note 5SYA 2043-02, 2012.
- [59] D. Zhou, F. Blaabjerg, T. Franke, M. Tonnes, and M. Lau, "Comparison of wind power converter reliability with low-speed and medium-speed permanent-magnet synchronous generators," *IEEE Trans. Ind. Electron.*, vol. 62, no. 10, pp. 6575–6584, Oct. 2015.
- [60] J. Rodriguez, S. Bernet, B. Wu, J. O. Pontt, and S. Kouro, "Multilevel voltage-source-converter topologies for industrial medium-voltage drives," *IEEE Trans. Ind. Electron.*, vol. 54, no. 6, pp. 2930–2945, Dec. 2007.
- [61] S. Kouro et al., "Recent advances and industrial applications of multilevel converters," *IEEE Trans. Ind. Electron.*, vol. 57, no. 8, pp. 2553–2580, Aug. 2010.
- [62] A. Faulstich, J. K. Stinke, and F. Wittwer, "Medium voltage converter for permanent magnet wind power generators up to 5 MW," in *Proc. EPE*, 2005, pp. 1–9.
- [63] J. Rodriguez, S. Bernet, P. K. Steimer, and I. E. Lizama, "A survey on neutral-point-clamped inverters," *IEEE Trans. Ind. Electron.*, vol. 57, no. 7, pp. 2219–2230, Jul. 2010.
- [64] B. Engel, M. Victor, G. Bachmann, and A. Falk, "15 kV/16.7 Hz energy supply system with medium frequency—Transformer and 6.5kV IGBTs in resonant operation," in *Proc. EPE*, Toulouse, France, Sep. 2003.
- [65] S. Inoue and H. Akagi, "A bidirectional isolated DC–DC converter as a core circuit of the next-generation medium-voltage power conversion system," *IEEE Trans. Power Electron.*, vol. 22, no. 2, pp. 535–542, Mar. 2007.
- [66] F. Iov, F. Blaabjerg, J. Clare, O. Wheeler, A. Rufer, and A. Hyde, "UNIFLEX-PM-A key-enabling technology for future European electricity networks," *EPE J.*, vol. 19, no. 4, pp. 6–16, 2009.
- [67] A. Q. Huang, M. L. Crow, G. T. Heydt, J. P. Zheng, and S. J. Dale, "The future renewable electric energy delivery and management (FREEDM) system: The energy Internet," *Proc. IEEE*, vol. 99, no. 1, pp. 133–148, Jan. 2011.
- [68] M. Davies, M. Dommasch, J. Dorn, J. Lang, D. Retzmann, and D. Soerangr, "HVDC plus—basics and principles of operation," Siemens, Munich, Germany, Tech. Rep., 2008.
- [69] A. Lesnicar and R. Marquardt, "An innovative modular multilevel converter topology suitable for a wide power range," in *Proc. IEEE Bologna Power Tech Conf.*, Jun. 2003, pp. 1–6.
- [70] K. Ma and F. Blaabjerg, "The impact of power switching devices on the thermal performance of a 10 MW wind power NPC converter," *Energies*, vol. 5, no. 7, pp. 2559–2577, 2012.
- [71] R. Jakob, C. Keller, and B. Gollentz, "3-Level high power converter with press pack IGBT," in *Proc. EPE*, Sep. 2007, pp. 2–5.
- [72] R. Alvarez, F. Filsecker, and S. Bernet, "Comparison of press-pack IGBT at hard switching and clamp operation for medium voltage converters," in *Proc. EPE*, 2011, pp. 1–10.
- [73] U. Scheuermann, "Reliability challenges of automotive power electronics," *Microelectron. Rel.*, vol. 49, nos. 9–11, pp. 1319–1325, 2009.
- [74] U. Scheuermann and R. Schmidt, "A new lifetime model for advanced power modules with sintered chips and optimized wire bonds," in *Proc. PCIM*, 2013, pp. 810–813.
- [75] J. Biela, M. Schweizer, S. Waffler, and J. W. Kolar, "SiC versus Si—Evaluation of potentials for performance improvement of inverter and DC–DC converter systems by SiC power semiconductors," *IEEE Trans. Ind. Electron.*, vol. 58, no. 7, pp. 2872–2882, Jul. 2011.
- [76] L. Yang, T. Zhao, J. Wang, and A. Q. Huang, "Design and analysis of a 270kW five-level DC/DC converter for solid state transformer using 10kV SiC power devices," in *Proc. IEEE PES*, Jun. 2007, pp. 245–251.

ABOUT THE AUTHORS

Frede Blaabjerg (Fellow, IEEE) received the Ph.D. degree in electrical engineering from Aalborg University, Aalborg, Denmark, in 1995.

He was with ABB-Scandia, Randers, Denmark, from 1987 to 1988. He became an Assistant Professor in 1992, Associate Professor in 1996, and Full Professor of power electronics and drives in 1998 at Aalborg University. His current research interests include power electronics and its applications such as in wind turbines, PV systems, reliability engineering, power quality, and adjustable speed drives.

Prof. Blaabjerg has received 18 IEEE Prize Paper Awards, the IEEE PELS Distinguished Service Award in 2009, the EPE-PEMC Council Award in 2010, the IEEE William E. Newell Power Electronics Award 2014 as well as the Villum Kann Rasmussen Research Award 2014. He was the Editor-in-Chief of the IEEE TRANSACTIONS ON POWER ELECTRONICS from 2006 to 2012. He was nominated by Thomson Reuters as one of the 250 most cited researchers in engineering in the world in 2014, 2015, and 2016. In 2017, he became Doctor Honoris Causa at the University of Politehnica, Timisoara, Romania.



Ke Ma (Member, IEEE) received the B.Sc. and M.Sc. degrees in electrical engineering from Zhejiang University, Zhejiang, China in 2007 and 2010, respectively, and the Ph.D. degree from Aalborg University, Aalborg, Denmark, in 2013.

He was a Postdoctoral Researcher at Aalborg University in 2013 and became an Assistant Professor in 2014. He was with Vestas Wind Systems A/S, Denmark, in 2015. In 2016, he joined the faculty of Shanghai Jiao Tong University, China as a tenure-track Research Professor. His current research interests include the design and enhancement of power electronics reliability in the application of renewable energy and motor drive systems.

Prof. Ma is an Associate Editor for the IEEE TRANSACTIONS ON INDUSTRY APPLICATIONS, and a Guest Associate Editor for IEEE JOURNAL OF EMERGING AND SELECTED TOPICS IN POWER ELECTRONICS. In 2016, he received the "Thousand Talents Plan Program for Young Professionals" award in China. He received the "Excellent Young Wind Doctor Award 2014" from the European Academy of Wind Energy and several prized paper awards from the IEEE.

