

WIND-INDUCED NOISE OF ARCHITECTURAL PERFORATED PLATES

Paul Vanoostveen^{*1} and Samir Ziada^{†1}

¹McMaster University, Hamilton, Ontario, Canada.

1 Introduction

Perforated plates are a common architectural feature which are known to produce noise when exposed to high winds. For certain conditions, this noise can be highly tonal and audible, which is an annoyance for inhabitants of the building.

Extensive work has been done in the literature to study flow over perforated plates at perpendicular or parallel angles of incidence. Flow through a perforated plate or orifice at a perpendicular direction may produce tonal noise due to an unsteady shear layer separating at the upstream corner of the orifice and impinging on the downstream corner. This effect occurs only for sharp-edged holes with a diameter of 1 to 2 times their length ($D/t = 1-2$). [1]

Similarly, parallel angles of incidence, or grazing flow, have been studied by many researchers for a variety of geometries, including perforated plates, orifices, and cavities. The case of tonal noise generation by grazing flow over a perforated surface is investigated in reference [2], with further details found in the works cited therein. In general, these tones are generated by the periodic impingement of vortices on the downstream corner of the holes. This periodic impingement causes a feedback which is felt upstream, leading to the repeated initiation of vortices at the upstream edge. This mechanism may be coupled with resonant or elastic effects, but can also occur purely due to the fluid dynamics.

Only a few researchers have looked at flow over perforated plates at oblique angles of incidence, where an oblique angle is defined as any angle which is not a multiple of 90° . This is important for architectural applications, since the direction of the wind is naturally varying. As an example, in reference [3], tonal noise was identified for flow over perforated plates at angles of incidence, θ , of 10° to 30° from parallel.

2 Method

2.1 Experimental apparatus

A simplified model of a perforated plate is used in this investigation. The circular holes of a typical perforated plate are replaced by a series of long rectangular slats with an adjustable gap width between them. This simplified model is studied experimentally in a wind tunnel for various angles of incidence and flow velocities. A cross-sectional view of the experimental apparatus is shown in Figure 1.

Four variables can be changed to study their effect. First, the gap width between the slats can be adjusted. The

slats can also be replaced with a standard perforated plate for validation of the results. Second, the mean velocity of the wind tunnel can be changed by adjusting the speed of its blower. Third, the angle of incidence of the plate can be changed by pivoting about a hinge at the edge of the wind tunnel outlet. Fourth and finally, the microphone position can be changed in the X , Y , and Z directions.

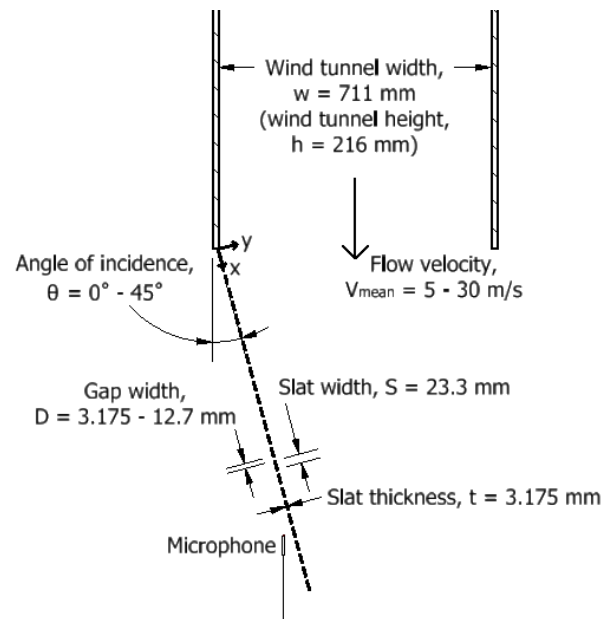

Figure 1: Experimental apparatus consisting of a series of rectangular slats mounted on an angle at the exit of an open circuit wind tunnel.

2.2 Acoustic measurements

A G.R.A.S. microphone, preamplifier, and power supply are used to measure the acoustic response of the test plates under various input conditions. The microphone is positioned 25.4mm from the back of the plates in the Y -direction and is moved by a traverse to various positions in the X -direction. For each test case, the microphone signal is recorded for 5 minutes at a sampling rate of 5000Hz , and the average frequency spectrum over that sampling window is calculated.

The frequency spectra are expressed using the dimensionless Strouhal number, St , where V_{mean} is the mean flow velocity, f is the frequency, and d is the characteristic dimension.

$$St = \frac{f * d}{V_{mean}} \quad (1)$$

^{*} vanoospj@mcmaster.ca

[†] ziadass@mcmaster.ca

For a perforated plate, d is defined as the hole diameter. For the rectangular slats, d is defined as the gap width multiplied by a factor of $(4/\pi)$.

2.3 Particle image velocimetry

Phase-locked particle image velocimetry (PIV) is used to calculate the velocity field between the slats. The flow is seeded with bis (2-ethylhexyl) sebacate particles and illuminated with a laser sheet positioned on the backside of the slats (negative Y -direction in Figure 1). A camera is positioned above the apparatus (Z -direction in Figure 1) to capture images of the area between the slats.

The images are phase-locked to the dominant tonal peak using the same microphone system as the acoustic measurements. Two-hundred images are taken at each phase, and the average flow field is calculated for each.

3 Results and discussion

3.1 Acoustic results

In Figure 2 below, the results of this research are compared with the results from literature. The black lines are the results of Feng [3] for $\theta = 15^\circ$ and $V = 15\text{m/s}$ for plates with a thickness of 1.5mm and 5 different hole diameters. For all cases, a peak is observed at a frequency of 2000 to 2500Hz . Using the experimental apparatus in Figure 1 and a perforated plate with a thickness of 1.5mm and a hole diameter of 6.35mm , a tone is produced at the same frequency as the results from literature. This is shown by the red line in Figure 2. The amplitudes of the results are not comparable due to different levels of background noise, different experimental apparatuses and different microphone locations.

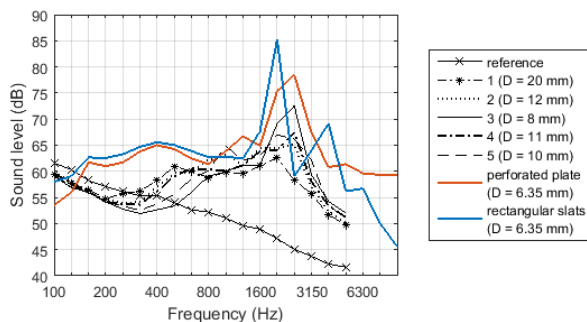

Figure 2: Acoustic results for $\theta = 15^\circ$ and $V = 15\text{m/s}$. The black lines are the results of Feng [3], and the colored lines are the results of this research.

The blue line in Figure 2 is for the two-dimensional model with a gap width equal to 6.35mm . The frequency of the largest peak is 2000Hz . This is slightly lower than the peak produced by the perforated plate. However, when the correction $(4/\pi)$ is applied, St is very similar. Both the perforated plates and the two-dimensional model produce tones for angles of incidence between 5° and 30° . For both, there is an optimal angle between 15° and 25° which produces the largest tonal peaks. For angles larger or smaller than optimal, the frequency of the peaks remains the

same, but the magnitude decreases. The optimal angle is larger for smaller hole diameters or gap widths.

Similarly, there is an optimal velocity at which tonal noise is produced for a given geometry. This optimal velocity is greater for smaller hole diameters or gap widths.

3.2 Particle image velocimetry results

Figure 3 shows the vorticity field for a single phase for the case of $\theta = 15^\circ$ and $V = 20\text{m/s}$. The black lines are contours of the d_2 parameter, which identifies vortices in the flow field [4]. Vortices form in the unsteady shear layer originating from the upstream slat and impinge on side of the downstream slat. At the downstream corner, these vortices separate into vortex pairs, where one half has positive vorticity and the other half has negative vorticity. These vortex pairs have a frequency equal to that of the measured tonal noise, and are therefore responsible for this noise.

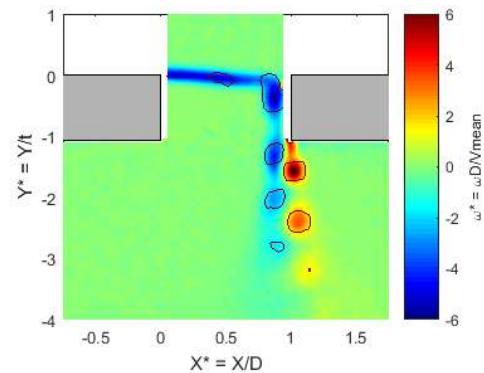

Figure 3: Particle image velocimetry results for $\theta = 15^\circ$ and $V = 20\text{m/s}$.

4 Conclusion

For flow over perforated plates at oblique angles of incidence, tonal noise is produced at $\theta = 5^\circ$ to 30° , with the optimal angle and velocity depending on the plate geometry. At the optimal conditions, this tonal noise is produced by the periodic shedding of vortex pairs at the trailing edge of the holes.

References

- [1] H. H. Heller and P. A. Franken, "Chapter 16: Noise of Gas Flow," in *Noise and Vibration Control*, Washington, 1988, pp. 515-524.
- [2] E. Celik and D. Rockwell, "Shear Layer Oscillation Along a Perforated Surface: A Self-Excited Large-Scale Instability," *Physics of Fluids*, vol. 14, no. 12, pp. 4444-4447, 2002.
- [3] L. Feng, "Tone-Like Signal in the Wind-Induced Noise of Perforated Plates," *Acta Acustica United With Acustica*, vol. 98, pp. 188-194, 2012.
- [4] H. Vollmers, "Detection of Vortices and Quantitative Evaluation of their Main Parameters from Experimental Velocity Data," *Measurement Science and Technology*, vol. 12, pp. 1199-1207, 2001.