

 Open access • Report • DOI:10.2172/6782774

Wind loads on flat plate photovoltaic array fields. Phase III, final report

— [Source link](#) 

R.D. Miller, D.K. Zimmerman

Published on: 01 Sep 1979

Topics: Wind direction, Wind tunnel, Wind speed, Aerodynamic force and Pressure gradient

Related papers:

- [Wind Loads on Flat Plate Photovoltaic Array Fields](#)
- [Wind loads on heliostats and photovoltaic trackers at various Reynolds numbers](#)
- [Wind loads on flat plate photovoltaic array fields \(nonsteady winds\)](#)
- [Wind Loads on Low-Profile, Tilted, Solar Arrays Placed on Large, Flat, Low-Rise Building Roofs](#)
- [Wind loads on heliostats and photovoltaic trackers of various aspect ratios](#)

Share this paper:    

View more about this paper here: <https://typeset.io/papers/wind-loads-on-flat-plate-photovoltaic-array-fields-phase-iii-367b764zfc>

2-25-81
M.E.

2

D. 2778

DOE/JPL/954833-81/3

WIND LOADS ON FLAT PLATE PHOTOVOLTAIC ARRAY FIELDS

Low Cost Solar Array Project Engineering Area. Phase III. Final Report

By
Ronald D. Miller
Donald K. Zimmerman

MASTER

April 1981

Work Performed Under Contract No. NAS-7-100-954833

Boeing Engineering and Construction Company
Seattle, Washington



U.S. Department of Energy



Solar Energy

DISCLAIMER

This report was prepared as an account of work sponsored by an agency of the United States Government. Neither the United States Government nor any agency Thereof, nor any of their employees, makes any warranty, express or implied, or assumes any legal liability or responsibility for the accuracy, completeness, or usefulness of any information, apparatus, product, or process disclosed, or represents that its use would not infringe privately owned rights. Reference herein to any specific commercial product, process, or service by trade name, trademark, manufacturer, or otherwise does not necessarily constitute or imply its endorsement, recommendation, or favoring by the United States Government or any agency thereof. The views and opinions of authors expressed herein do not necessarily state or reflect those of the United States Government or any agency thereof.

DISCLAIMER

Portions of this document may be illegible in electronic image products. Images are produced from the best available original document.

DISCLAIMER

"This book was prepared as an account of work sponsored by an agency of the United States Government. Neither the United States Government nor any agency thereof, nor any of their employees, makes any warranty, express or implied, or assumes any legal liability or responsibility for the accuracy, completeness, or usefulness of any information, apparatus, product, or process disclosed, or represents that its use would not infringe privately owned rights. Reference herein to any specific commercial product, process, or service by trade name, trademark, manufacturer, or otherwise, does not necessarily constitute or imply its endorsement, recommendation, or favoring by the United States Government or any agency thereof. The views and opinions of authors expressed herein do not necessarily state or reflect those of the United States Government or any agency thereof."

This report has been reproduced directly from the best available copy.

Available from the National Technical Information Service, U. S. Department of Commerce, Springfield, Virginia 22161.

Price: Printed Copy A17
Microfiche A01

WINDS LOADS ON
FLAT PLATE PHOTOVOLTAIC ARRAY FIELDS

JPL Contract No. 954833

Low Cost Solar Array Project
Engineering Area

Phase III Final Report

April 1981

Ronald D. Miller
Donald K. Zimmerman

"The JPL Low Cost Solar Array Project is sponsored by the U. S. Department of Energy and forms part of the Solar Photovoltaic Conversion Program to initiate a major effort toward the development of low-cost solar arrays. This work was performed for the Jet Propulsion Laboratory, California Institute of Technology by agreement between NASA and DOE."

Prepared for

Jet Propulsion Laboratory
4800 Oak Grove Drive
Pasadena, California 91103

By the

Boeing Engineering and Construction Company
(A Division of The Boeing Company)
Seattle, Washington

THIS PAGE
WAS INTENTIONALLY
LEFT BLANK

Acknowledgements

Management and engineering on this project was provided by the Solar Systems organization of the Boeing Engineering and Construction Company (a Division of The Boeing Company). Dr. Ronald Ross and Mr. Robert Weaver, Manager and technical monitor, respectively, in the Engineering area of the Low Cost Solar Array Project, Jet Propulsion Laboratory, California Institute of Technology, contributed many helpful suggestions during the program, particularly in the preparation of the wind tunnel test plan. The wind tunnel test was performed by the Fluid Dynamics Laboratory staff of Colorado State University, Fort Collins, Colorado. The responsible Manager for the testing was Dr. Jack E. Cermak, the Project Director was Dr. Jon A. Peterka, and Principal Investigators were N. Hosoya and Dr. Mike Poreh.

Table of Contents

1.0	SUMMARY	1
2.0	INTRODUCTION	5
2.1	Study Objectives	5
2.2	Discussion and Background	6
2.3	Study Requirements	7
2.4	Report Organization	8
3.0	BASIC AERODYNAMIC EQUATIONS AND DEFINITIONS	13
3.1	Analysis Definitions and Nomenclature	13
3.2	Solar Energy-Aerodynamic Synonyms	16
3.3	Aerodynamic Sign Convention and Basic Equations	17
4.0	WIND TUNNEL TEST PROGRAM AND RESULTS	19
4.1	Uniform Wind Velocity Profile	20
4.2	1/7 Power Law Wind Velocity Profile	22
4.2.1	Array Mid-Span Wind Loads Without a Protective Wind Barrier (Fence)	22
4.2.2	Array Mid-Span Wind Loads With a Protective Wind Barrier (Fence)	23
4.2.3	Array Edge Wind Loads for Straight-On Winds	24
4.2.4	Array Edge Wind Loads for Oblique Winds	25
4.3	Comparison of Wind Tunnel Test Results for Uniform Wind Profile and 1/7 Power Law Wind Profile	28
4.4	Test Results Summary	29
5.0	THEORETICAL - EXPERIMENTAL RESULTS COMPARISON	73
6.0	DISCUSSION AND CONCLUSIONS	83
7.0	STEADY STATE WIND LOADS DESIGN GUIDELINES	87
7.1	Wind Loads on Arrays Behind a Protective Wind Barrier	87
7.2	Wind Loads on Arrays Without a Protective Wind Barrier	91
7.3	Array Edge Wind Loads	92
8.0	NEW TECHNOLOGY	101
9.0	REFERENCES	103
	APPENDIX A	1A
	APPENDIX B	1B
	APPENDIX C	1C

Figures

No.		Page
1-1	Steady State Wind Normal Force and Normalized Pressure Coefficient Envelope for Arrays Behind a Protective Wind Barrier	3
2-1	Array Variables Used to Study Aerodynamic Loads	10
2-2	Photovoltaic Array Field	11
2-3	Definition of an Array	11
4-1a	Array Chordwise Pressure Coefficient Distribution in Uniform Wind Velocity Profile (Tilt Angle = 20°, Wind from Front).	30
4-1b	Array Chordwise Pressure Coefficient Distribution in Uniform Wind Velocity Profile (Tilt Angle = 20° Wind from Rear)	31
4-1c	Array Chordwise Pressure Coefficient Distribution in Uniform Wind Velocity Profile (Tilt Angle = 35°, Wind from Front)	32
4-1d	Array Chordwise Pressure Coefficient Distribution in Uniform Wind Velocity Profile (Tilt Angle = 35°, Wind from Rear)	33
4-1e	Array Chordwise Pressure Coefficient Distribution in Uniform Wind Velocity Profile (Tilt Angle = 60°, Wind from Front)	34
4-1f	Array Chordwise Pressure Coefficient Distribution in Uniform Wind Velocity Profile (Tilt Angle = 60°, Wind from Rear)	35
4-1g	Array Chordwise Pressure Coefficient Distribution in Uniform Wind Velocity Profile (Tilt Angle = 90°)	36
4-2	1/7 Power Law Wind Velocity Profile	37

	Page	
4-3a	Array Chordwise Pressure Coefficient Distribution in Boundary Layer Wind (Tilt Angle = 20°, Wind from Front)	38
4-3b	Array Chordwise Pressure Coefficient Distribution in Boundary Layer Wind (Tilt Angle = 20°, Wind from Rear)	39
4-3c	Array Chordwise Pressure Coefficient Distribution in Boundary Layer Wind (Tilt Angle = 35°, Wind from Front)	40
4-3d	Array Chordwise Pressure Coefficient Distribution in Boundary Layer Wind (Tilt Angle = 35°, Wind from Rear)	41
4-3e	Array Chordwise Pressure Coefficient Distribution in Boundary Layer Wind (Tilt Angle = 60°, Wind from Front)	42
4-3f	Array Chordwise Pressure Coefficient Distribution in Boundary Layer Wind (Tilt Angle = 60°, Wind from Rear)	43
4-3g	Array Chordwise Pressure Coefficient Distribution in Boundary Layer Wind (Tilt Angle = 90°)	44
4-4	Effect of Head-On and Rearward Winds on Array Normal Force Coefficients (No Fence)	45
4-5	Effect of a Fence on Array Chordwise Pressure Coefficient Distribution for Head-On and Rearward Winds	46
4-6	Effect of a Fence on Array Normal Force Coefficients for Head-On and Rearward Winds	47
4-7	Array Chordwise Pressure Coefficient Distribution Located .15 Chord Lengths from Side Edge for Head-On and Rearward Winds (No Fence)	48
4-8	Effect of Fence on Array Chordwise Pressure Coefficient Distribution Located .15 Chord Lengths from Side Edge for Head-On and Rearward Winds	49
4-9	Comparison Between Array Edge and Center of Span Normal Force Coefficients for Head-On and Rearward Winds (No Fence)	50

	Page	
4-10	Effect of Fence on Array Edge Normal Force Coefficients for Head-On and Rearward Winds	50
4-11a	Effect of Oblique Winds on Array Edge Pressure Distribution (No Fence, Wind from Front)	51
4-11b	Effect of Oblique Winds on Array Edge Pressure Distribution (No Fence, Wind from Rear)	53
4-11c	Effect of Oblique Winds on Array Edge Pressure Distribution (Conventional Fence, Wind from Front)	54
4-11d	Effect of Oblique Winds on Array Edge Pressure Distribution (Conventional Fence, Wind from Rear)	55
4-11e	Effect of Oblique Winds on Array Edge Pressure Distribution (Conventional Fence, Endplated Arrays, Wind from Front)	56
4-11f	Effect of Oblique Winds on Array Edge Pressure Distribution (Conventional Fence, Endplated Arrays, Wind from Rear)	57
4-11g	Effect of Oblique Winds on Array Edge Pressure Distribution (Modified Fence Corner, Wind from Front)	58
4-11h	Effect of Oblique Winds on Array Edge Pressure Distribution (Modified Fence Corner, Wind from Rear)	59
4-12	Effect of Oblique Winds on Array Normal Force Coefficients at Array Edge	60
4-13	Maximum Pressure Coefficient at Array Side Edge Due to Oblique Winds	61
4-14a	Array Pressure Coefficient Comparison Between Uniform and Boundary Layer Wind Profiles (Tilt Angle = 20°, Wind from Front)	62
4-14b	Array Pressure Coefficient Comparison Between Uniform and Boundary Layer Wind Profiles (Tilt Angle = 20°, Wind from Rear)	63
4-14c	Array Pressure Coefficient Comparison Between Uniform and Boundary Layer Wind Profiles (Tilt Angle = 35°, Wind from Front)	64
4-14d	Array Pressure Coefficient Comparison Between Uniform and Boundary Layer Wind Profiles (Tilt Angle = 35°, Wind from Rear)	65
4-14e	Array Pressure Coefficient Comparison Between Uniform and Boundary Layer Wind Profiles (Tilt Angle = 60°, Wind from Front)	66

	<u>Page</u>	
4-14f	Array Pressure Coefficient Comparison Between Uniform and Boundary Layer Wind Profiles (Tilt Angle = 60°, Wind from Rear)	67
4-14g	Array Pressure Coefficient Comparison Between Uniform and Boundary Layer Wind Profiles (Tilt Angle = 90°)	68
4-15	Array Normal Force Coefficient Comparison Between Uniform and Boundary Layer Wind Profiles	69
4-16	Configurations for Edge Load Reduction Study	71
5-1	Array Pressure Coefficient Distribution Comparison Between Wind Tunnel Test and Theoretical Methods in Free Air	76
5-2a	Array Pressure Coefficient Distribution Comparison Between Wind Tunnel Test and Theoretical Methods in Close Ground Proximity (Tilt Angle = 20°)	77
5-2b	Array Pressure Coefficient Distribution Comparison Between Wind Tunnel Test and Theoretical Methods in Close Ground Proximity (Tilt Angle = 35°)	78
5-2c	Array Pressure Coefficient Distribution Comparison Between Wind Tunnel Test and Theoretical Methods in Close Ground Proximity (Tilt Angle = 60°)	79
5-3	Effect of Ground Clearance on Front and Back Array Pressures in Uniform Flow (Tilt Angle = 60°, Wind from Back)	80
5-4	Array Normal Force Coefficient Comparison Between Wind Tunnel Test and Theoretical Methods	81
5-5	Theoretical Key Wind Loads Parameters and Their Sensitivity in Separated Flow analyses (Reference 5)	82
7-1a	Steady State Wind Normal Force Coefficient Envelope for Arrays Within an Array Field or Behind a Protective Wind Barrier	94
7-1b	Steady State Wind Normalized Pressure Coefficient Envelope for Arrays Within an Array Field or Behind a Protective Wind Barrier	95
7-2a	Steady State Wind Normal Force Coefficient Envelope for the Two Outer Boundary Array Rows in an Array Field Unprotected from the Wind	96
7-2b	Steady State Wind Normalized Pressure Coefficient Envelope for the Two Outer Boundary Array Rows in an Array Field Unprotected from the Wind	97

7-3a	Steady State Wind Pressure Coefficient and Normal Force Coefficient Guidelines for Edge Arrays in an Array Field (No Fence)	98
7-3b	Steady State Wind Pressure Coefficient and Normal Force Coefficient Guidelines for Edge Arrays in an Array Field (Fence)	99
7-3c	Steady State Wind Pressure Coefficient and Normal Force Coefficient Guidelines for Edge Arrays in an Array Field (Fence with Modified Corners)	100

Tables

No.		Page
4-1	Array Test Conditions	22
5-1	Example of Average Normal Wind Forces on Arrays Behind Protective Fences by Theoretical and Wind Tunnel Test Methods	75

1.0 SUMMARY

This report presents the results of an experimental analysis (boundary layer wind tunnel test) of the aerodynamic forces resulting from winds acting on flat plate photovoltaic arrays. Local pressure coefficient distributions and normal force coefficients on the arrays are shown and compared to theoretical results. Parameters that were varied when determining the aerodynamic forces included tilt angle, array separation, ground clearance, protective wind barriers, and the effect of the wind velocity profile. Recommended design wind forces and pressures are presented, which envelop the test results for winds perpendicular to the array's longitudinal axis. This wind direction produces the maximum wind loads on the arrays except at the array edge where oblique winds produce larger edge pressure loads.

The arrays located at the outer boundary of an array field have a protective influence on the interior arrays of the field. A significant decrease of the array wind loads were recorded in the wind tunnel test on array panels located behind a fence and/or interior to the array field compared to the arrays on the boundary and unprotected from the wind. The magnitude of this decrease was the same whether caused by a fence or upwind arrays. Figure 1-1 shows typical envelopes of the wind loads on arrays that are presented in this report. This figure is for arrays interior to an array field or on the boundary of a field when a fence exists to protect the front arrays. Since these loads envelop the measured wind tunnel results, they can be used as guideline design steady-state wind loads on photovoltaic arrays with wind protection. Similar guideline wind loads are given in the report for arrays unprotected from the wind.

The wind loads on the arrays within two slant heights from the side edges are considerably different from the remainder of the array field. Vortices are produced by the array corners and at the fence corner if a fence exists. These vortices cause local high pressure loads on or near the array edges. Several methods to reduce the strength of the vortices and resulting pressures were tried with limited success. Endplating the arrays (completely enclosing the ends of the arrays with a 50% porosity plate to simulate shrubs or gates at the array ends) was the most successful in reducing the wind loads on the array side edges, decreasing these loads by approximately 50%. Modifying the fence corner was also successful but to a lesser extent than endplating the arrays.

However, the edge pressures are, at best, several times larger than the pressure several slant heights away from the side edge.

Theoretically calculated steady state wind loads were larger in magnitude than wind tunnel determined wind loads. Wind tunnel determined wind loads using a uniform wind profile and a 1/7 boundary layer wind profile were similar in shape and magnitude. The magnitude of the wind loads for the uniform wind profile, although similar to the boundary layer profile, were not consistently larger or smaller than the boundary layer profile results and thus could not be used reliably for design purposes in preference to the boundary layer results.

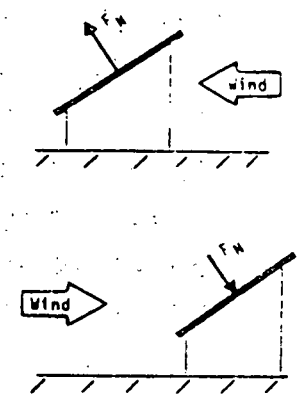
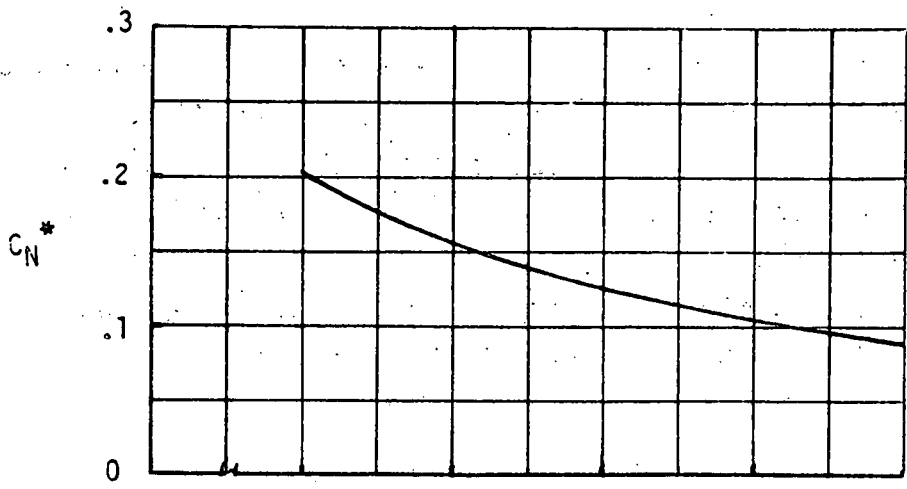

* C_N based on wind reference velocity at 10 meters

exception: not valid within two slant heights from the side edges

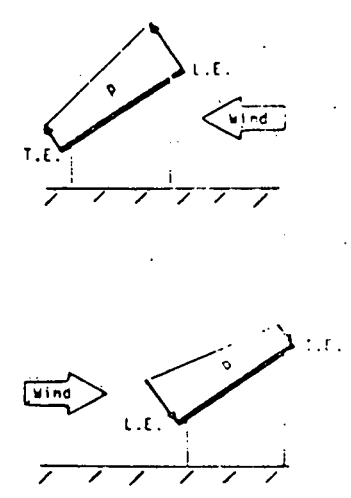
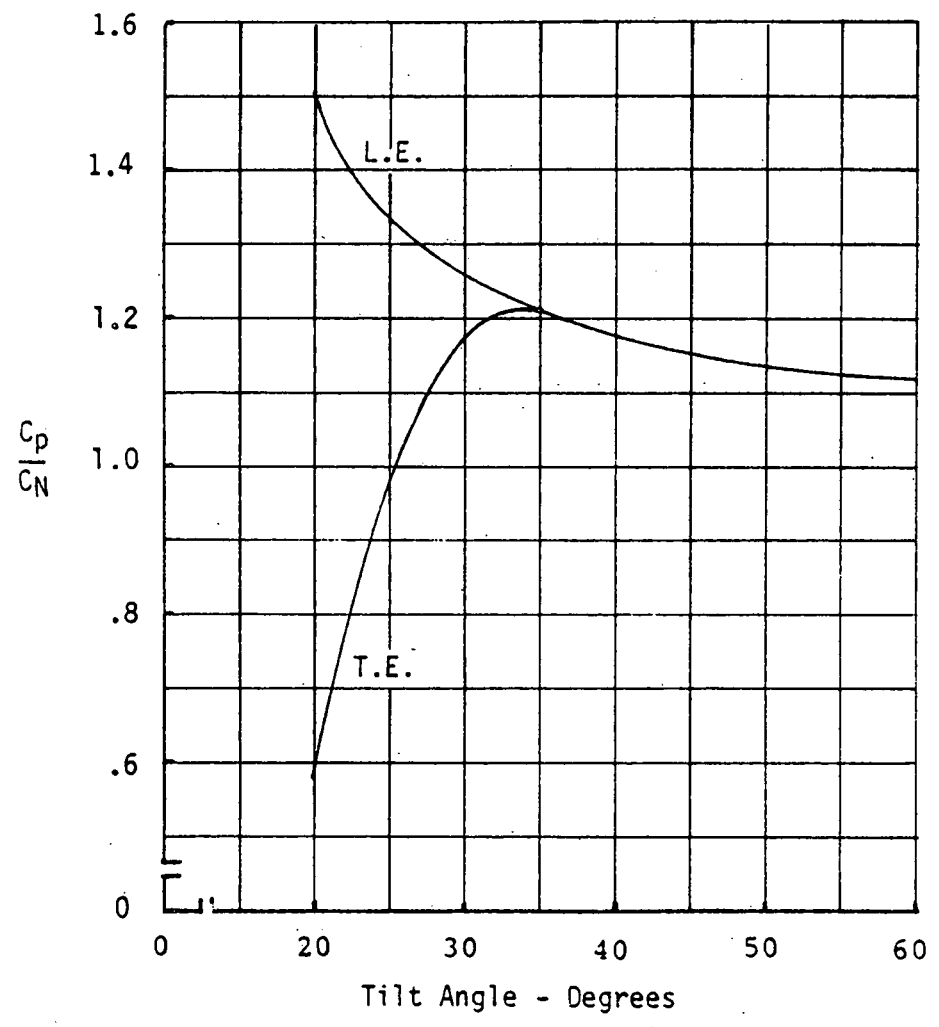

Figure 1-1. Steady State Wind Normal Force and Normalized Pressure Coefficient Envelope for Arrays Behind a Protective Wind Barrier

THIS PAGE
WAS INTENTIONALLY
LEFT BLANK

2.0 INTRODUCTION

This report summarizes an experimental analysis (wind tunnel test) of the aerodynamic loading on long, flat plate photovoltaic arrays resulting from exposure to the wind environments, evaluates and compares test results to theoretical results, and presents guidelines for aerodynamic loads to be used in the design of specific photovoltaic arrays. This report is an extension to the theoretical analysis reported in DOE/JPL 954833-79/2. The study was performed under contract number 954833 to the Jet Propulsion Laboratory as part of the Engineering Area Task of the Low-Cost Solar Array (LSA) Project. This project is being managed by JPL for the Department of Energy, Division of Solar Technology.

2.1 Study Objectives

The Department of Energy (DOE) photovoltaic program¹ has the overall objective to ensure that photovoltaic conversion systems will contribute significantly (50 Gwe) to the nation's energy supply by the year 2000. The cost associated with the design and construction of solar photovoltaic arrays to produce electric energy from sunlight is an important factor in the acceptance and use of solar energy. DOE has established specific price goals to produce energy at 55-92 mills/KW-h by 1986 (expressed in constant 1980 dollars) which are deemed necessary to achieve the desired industry growth and market penetration. Therefore, it is necessary in the trade-off phase of system design to ensure that the design requirements are realistic. The objective of this study was to establish wind load guidelines for flat plate photovoltaic arrays with various configurations in relation to chord lengths, array spacings, height of arrays from the ground, wind direction, array angles of attack, and with and without protective fences used to reduce the wind loading (see Figure 2-1). The guidelines were to be established by theoretical aerodynamic methods and experimental techniques. Wind tunnel testing was to be used to verify the theoretical results reported in reference 5 and to determine steady state wind loads on arrays for conditions that cannot presently be obtained by theoretical methods. These loads are required to ensure realistic design requirements.

2.2 Discussion and Background

The load due to wind on an array and on its support structure strongly influences the design and ultimately the cost of the photovoltaic panels, panel and array support structure and foundations of the arrays. A previous design study of flat plate array support structure showed that the arrays (structural framework and foundation) costs were of the same order of magnitude as the photovoltaic module costs. Furthermore, the array costs were strongly dependent on the assumed wind loading for loading in the range of 35 to 75 psf. Another study, using transparent inflated enclosures to protect the modules³, predicted wind loadings on the enclosures near the low end of the range compared to those used in reference 2, and showed significant cost savings compared to conventional arrays with similar wind loading criteria. It is, therefore, essential to determine the true maximum wind load that the array will experience during its lifetime in order to minimize the structure cost.

Three factors affect the amount of wind loading on a body: the flow field in which the body is placed, the aerodynamic characteristics of the body itself, and the dynamic response of the body due to the wind loading. Although the structural loads resulting from this latter factor are not totally composed of aerodynamic forces (they also include inertia forces), these structural loads do result from the wind loading, or more precisely, the fluctuations in wind loading.

A flow field of the type that would be found around arrays in an array field situated in an open terrain, as depicted in Figure 2-2, has three aspects: 1) the steady state flow before it encounters any obstacles, 2) atmospheric gusts, and 3) turbulence. The steady state flow consists of a shear layer adjacent to the ground whose shearing effects decrease with elevation above the ground until a uniform flow is attained. The shear layer for most open flatlands can be modeled as a 1/7 power law⁴. Gusting is the result of velocity variations and changes in the direction of the prevailing wind due to atmospheric instabilities. Turbulence may be caused by several factors. Gusting can cause turbulence when adjacent volumes of air are moving at different velocities, thus producing a shearing effect. The roughness of the land causes turbulence because of shearing effects. An obstacle in the path of the flow can also create turbulence by upsetting the flow and thus causing eddies and vortices to

form. In addition, the shape of the body will affect the characteristics of the turbulence. Turbulent flow is highly complex, with varying frequencies and intensities occurring in a random manner.

The body in the case of a photovoltaic array consists of modules assembled on a framework that is mounted on a support structure (Fig. 2-3). The aerodynamic characteristics of an array are the same as those of a flat plate when only steady state flow is considered. When gusting and turbulence are introduced, these characteristics are not as well defined; however, the aerodynamics for a flat plate are a good approximation in lieu of a more detailed structural design. The effect on the array forces due to the flow field are a function of the type of impingement and the resulting pressure distribution over the array. When the flow is turbulent, the pressure distribution and, consequently, the forces exerted on the array are nonuniform in frequency and intensity. These forces may cause vibrations in the structure resulting in additional structural dynamic forces on the array. Since turbulence varies in frequency and intensity, the resulting loading will also vary as a function of the frequency and intensity.

2.3 Study Requirements

The requirements of this study involve analysis and test within five specific areas. They are:

1. Wind tunnel test plan.
2. Wind tunnel test.
3. Test and theoretical results analysis and comparison.
4. Modification of theoretical results to reflect empirical results.
5. Establishment of design guidelines for estimating wind loads on photovoltaic arrays.

The following is a summary of the statement of work for Phase III.

- o Verify the analytic results obtained in Phase II and expand the effort to establish wind load and pressure distributions that can be used

as module and support structure design guidelines by performing the following four tasks.

1) Task 1 - Pre-Test Planning

Review the data requirements from the Phase II work for meeting Phase III objectives and optimize the wind tunnel test conditions and configurations that will meet the data requirements.

2) Task 2 - Wind Tunnel Testing

Based on the requirements determined in Task 1, perform the required wind tunnel tests. Review the preliminary data during the test program and modify the test plan as required to ensure that the data requirements are met.

3) Task 3 - Data Analysis

- a) Compare the wind tunnel results with the results of Phase II and determine the validity of the analytically identified key load parameters.
- b) Modify the results of Phase II to reflect the empirical results.

4) Task 4 - Design Guidelines

- a) Establish design guidelines for estimating the wind loads on the support structure as a function of the wind velocity and array field configuration.
- b) Establish design guidelines for estimating the pressure distribution on flat plate modules for varying wind velocities and array field configurations.

2.4 Report Organization

The remainder of this report presents the results of the wind tunnel test and its comparison to the theoretical results presented in reference 5 and the proposed design wind loads and conclusions. Section 3.0 presents basic

aerodynamic equations, definitions, and nomenclature for use in understanding the results. Section 4.0 presents the wind tunnel program and results. A comparison of theoretical results to experimental results is presented in Section 5.0. A discussion of the results of Sections 4.0 and 5.0 is included in Section 6.0 together with conclusions obtained from the results. Section 7.0 presents array wind load envelopes that may be used for design guidelines. New technology and References are outlined in Sections 8.0 and 9.0, respectively. The wind tunnel test report which includes test description and data from the tests conducted at Colorado State University in their Meteorological Wind Tunnel Facility is presented in the Appendix.

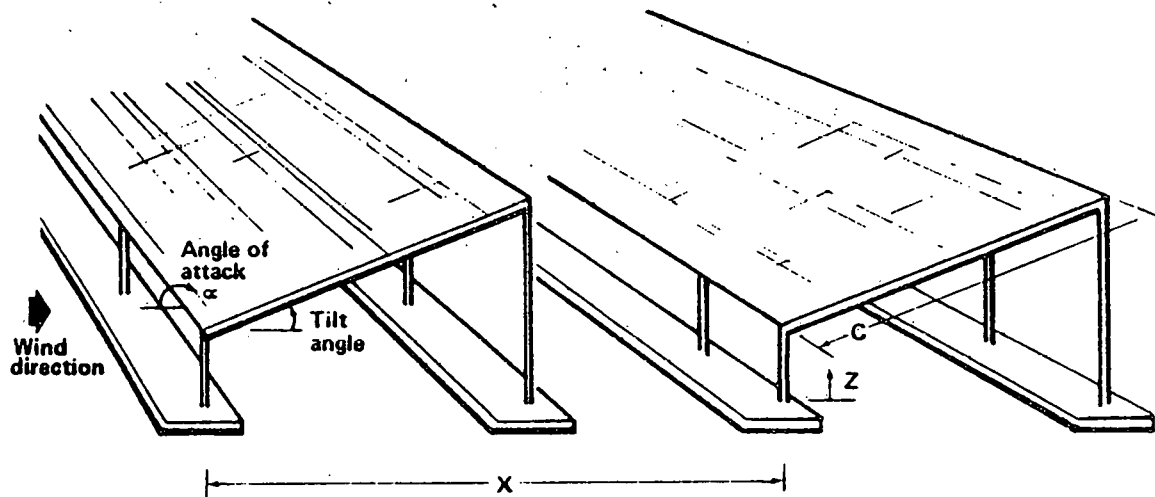

Ground clearance (Z)
Array spacing (X)
Tilt angle
Wind direction

Figure 2-1. Array Variables Used to Study Aerodynamic Loads

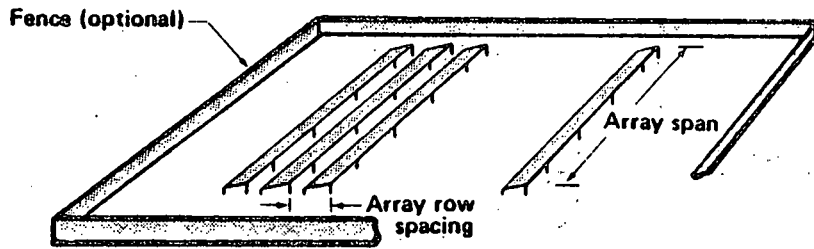

Figure 2-2. Photovoltaic Array Field

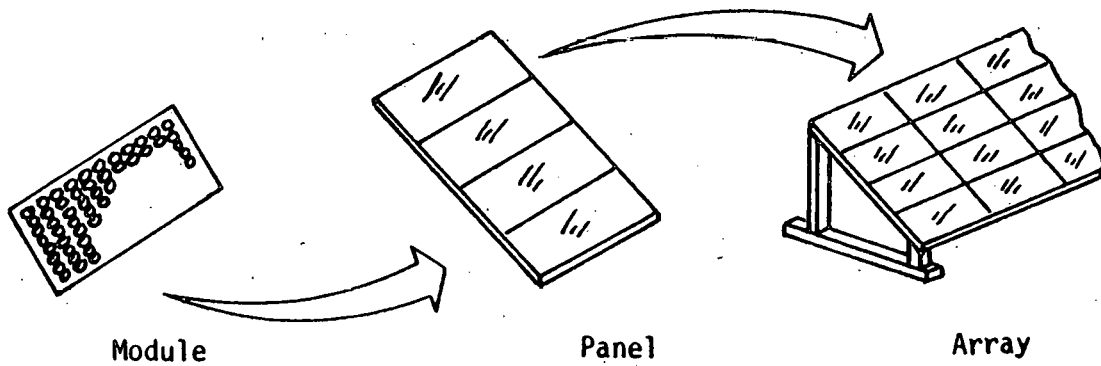

Figure 2-3. Definition of an Array

THIS PAGE
WAS INTENTIONALLY
LEFT BLANK

3.0 BASIC AERODYNAMIC EQUATIONS AND DEFINITIONS

The analyses used in this report required the use of aerodynamic results that were calculated in aerodynamic terms. Since these terms may be unfamiliar to designers of photovoltaic arrays, this section explains the basic aerodynamic terms and nomenclature and defines basic aerodynamic equations to assist those without an aerodynamic background to understand the results. In addition, synonyms between aerodynamic and solar energy terms are given where applicable.

3.1 Analysis Definitions and Nomenclature

Aerodynamic coefficients:	non-dimensional coefficients.
pressure coefficient (C_p):	relates lifting surface pressure to reference freestream dynamic pressure, $C_p = p/q$.
$C_{p\alpha}$	slope of the pressure coefficient curve; relates pressure coefficient to angle of attack, $C_p = C_{p\alpha}\alpha$.
ΔC_p	net pressure coefficient on lifting surface = windward face pressure coefficient minus base pressure coefficient.
normal force (F_n, F_N):	force normal to the lifting surface (positive out of base pressure face).
normal force coefficient (C_n, C_N):	relates lifting surface normal force to reference freestream dynamic pressure and reference area, $C_N = F_n/qA$.
$C_{N\alpha}$	slope of the normal force coefficient curve, relates normal force coefficient to angle of attack, $C_N = C_{N\alpha}\alpha$.

lift (L)	force on the lifting surface perpendicular to the freestream velocity (positive up).
lift coefficient (C_L)	relates lift to reference freestream dynamic pressure and reference area, $C_L = L/qA$.
drag (D)	force on the lifting surface parallel to the freestream velocity (positive in the wind direction).
drag coefficient (C_D)	relates drag to reference freestream dynamic pressure and reference area, $C_D = D/qA$.
center of pressure (X)	location of total force on lifting surface measured from the leading edge.
Angle of attack:	angle measured from the wind vector to the plane of the lifting surface.
Array:	a mechanically integrated assembly of panels together with support structure (including foundations).
Array field:	the aggregate of all arrays.
Array spacing:	horizontal distance measured from one array to the identical location on the next array.
Aspect ratio (AR):	aerodynamic geometric parameter (span/chord for a rectangular array).
Base pressure face:	downwind side of lifting surface.

Bluff body: a nonstreamline body that causes airflow about itself to become separated and turbulent.

Chord (C): distance of array between leading and trailing edges and perpendicular to the edges, i.e.: slant height of array.

Dynamic pressure (q): pressure due to freestream velocity at a reference height ($q = .5\rho V^2$).

Ground clearance (Z): distance between the ground and the lowest point on the panels forming the array.

Inviscid: frictionless flow.

Leading edge (L.E.): windward edge of the array.

Module: the smallest complete environmentally protected assembly of solar cells.

Normal wash, downwash: flow of air perpendicular to the lifting surface plane.

Panel: a collection of one or more modules fastened together forming a field installable unit.

Plate: thin rectangular shaped structure that acts as a lifting surface.

Pressure (p): force per unit area.

Span (b): distance of an array between the two side edges i.e.: length of array.

Tilt Angle:	angle measured from the horizontal to the plane of the array panels.
Trailing Edge (TE):	downwind edge of the array
Viscous:	flow that has friction.
Windward face:	windward side of lifting surface.
Yaw angle:	angle measured from wind direction to the normal of the array leading edge.
A:	reference area of array or portion of the array
l :	length
V:	velocity.
ρ :	air density.
μ :	coefficient of viscosity.
S :	area of lifting surface.
S:	distance measured along the chord from a reference point.

3.2 Solar Energy - Aerodynamic Synonyms

<u>Solar Energy</u>	<u>Aerodynamics</u>	<u>Comments</u>
Tilt angle and wind direction	Angle of attack, symbol is α	Restricted to horizontal winds
Slant height	Chord	
Wind angle	Yaw angle	

3.3 Aerodynamic Sign Convention and Basic Equations

Sign Convention:

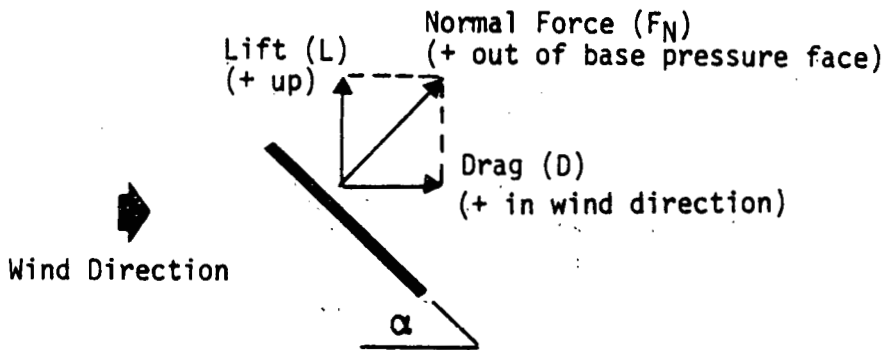
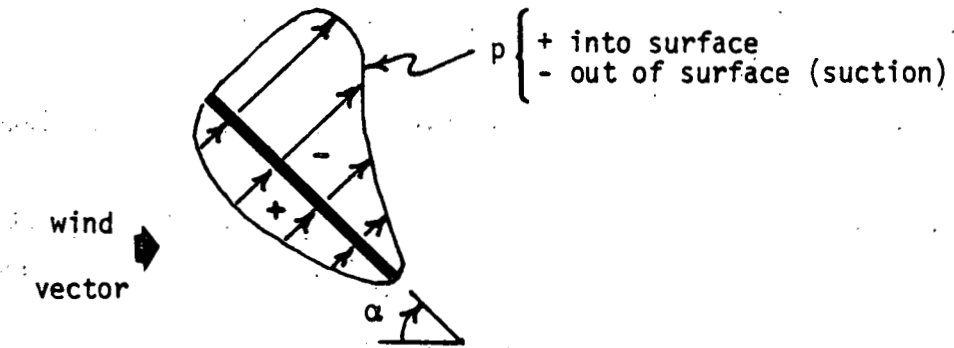

Aerodynamic Equations:

1. Pressures and pressure coefficients are related by:

$$p = q C_p$$

2. Normal forces and normal force coefficients are related by:

$$F_N = q S C_n$$

3. When the pressure coefficients and normal force coefficients are linear with respect to angle of attack, the above expressions can be changed to:

$$p = q C_{p\alpha} \alpha$$

$$F_n = q S C_{n\alpha} \alpha$$

4. Normal force coefficient for chordwise strips can be obtained from the pressure coefficients by integrating the pressure coefficient along the chord and is expressed by:

$$C_n = \frac{1}{c} \int_c C_p$$

or for a surface as:

$$C_n = \frac{1}{S} \int_s C_p$$

5. Lift and drag coefficients are related to the normal force coefficient by the angle of attack as:

$$C_L = C_n \cos \alpha$$

$$C_D = C_n \sin \alpha$$

6. Lift and drag forces are given by:

$$L = q S C_L$$

$$D = q S C_D$$

4.0 WIND TUNNEL TEST PROGRAM AND RESULTS

A wind tunnel test program was developed to verify the theoretical results in reference 5 and to obtain test data for conditions not presently suitable for theoretical analysis. The test plan included the testing of wind loads on single arrays, arrays within an array field, the effect of fences on arrays in an array field, and the effect of wind velocity profiles (uniform and 1/7 power law). The emphasis of the program was the testing of arrays in an array field with a boundary layer wind having a 1/7 power law velocity profile referenced at 10 meters. This wind profile was used to represent the winds found in nature in open flat terrain. The array parameters varied using this wind profile were: (1) array separation (1.5, 2.0, and 3.0C), (2) tilt angle (20°, 35°, 60°, and 90°), (3) wind direction (front, rear, and oblique winds of 45° and 135° from the front), (4) fence (with and without), (5) fence porosity (0% and 30%), and (6) fence-array separation (1.25, 2.5, and 5.0C). The array parameters not varied were the slant height (C) and the array ground clearance of .25C. Several modifications to the fence corner and array edges were tested with oblique winds in an attempt to reduce the array edge loads. A complete list of the test configurations is listed in Table 18, Appendix A. The fence corner modifications are detailed in Table 17, Appendix A, and the array edge modifications are shown in Figure 24, Appendix A.

A number of test runs were conducted utilizing a uniform velocity profile. These tests did not include any fence effects or effects of oblique winds. The tests included variations of tilt angle and array separation in an array field. Single arrays were also tested varying the tilt angle and the array ground clearance. Corresponding single array tests were performed with a 1/7 power law velocity profile for comparison to the uniform velocity profile results.

The wind tunnel testing was conducted in the Meteorological Wind Tunnel at Colorado State University (see Figure 1, Appendix A). This tunnel is characterized by a long (96 ft.) test section that is 6 ft. 8 in. wide by 6 ft. high. The long test section is required to properly develop and stabilize the boundary layer velocity profile used in the tests. Testing in a boundary layer wind profile is performed at the rear of the test section whereas testing in a uniform wind velocity profile is performed at the front of the test section.

The array model tested was a 1:24 scale of an eight ft. chord full size array. Pressure taps were located at the mid-span and edge locations as shown in Figure 10, Appendix A. Ten pressure taps were located on each of the front and rear faces of the array and at each span location. The spacing of the taps were varied such as to have more taps near the leading and trailing edges of the array. Pressures at each tap were recorded digitally for 16 seconds by means of a pressure switch to a Setra differential transducer which was sampled at 250 times per second. The test data acquisition, data reduction as well as the testing procedures are detailed in Appendix A. The recorded test data in its entirety is presented in Appendix B and the computer plotted test data in Appendix C.

The following sections present significant findings from the test results. Section 4.1 details the results from the uniform wind velocity profile for an array field. Section 4.2 presents the results from the 1/7 power law wind profile and section 4.3 shows the comparison of the wind loads on a single array due to a uniform and a boundary layer wind. Section 4.4 summarizes the significant test results.

4.1 Uniform Wind Velocity Profile

Figures 4-1a through 4-1g, show the net or delta pressure coefficient distribution (the windward face pressure coefficient minus the base pressure coefficient) along the chord for an array field positioned at four tilt angles and with a uniform velocity profile wind from both front and rearward directions. In all of these cases, the arrays are .25 slant heights above the ground and separated by a distance of two slant heights. Other array separation distances (1.5 and 3.0 slant heights) were tested. Since the results from the three array separations are similar, only the results of the 2.0 slant height separation tests are used to discuss significant findings. The pressures on the arrays, each recorded in the test for sixteen seconds, were used to calculate average and rms pressure coefficients. The rms pressures are an indication of the pressures to be expected from the turbulence generated by the arrays. However, the rms pressures do not reveal any characteristics of the flow such as the phase angle of the pressure between locations or the frequency content of the pressures. These parameters are very important to predict dynamic pressures and forces on the structure and will be reported in a future report.

The first windward array in the array field experiences by far the highest mean pressure coefficients and resulting normal forces for all tilt angles. In contrast to the mean pressures, the rms values of the unsteady pressure coefficients caused by the array induced wind turbulence is the smallest on the first windward array. The turbulence in the wind tunnel for the free stream wind prior to the array field is essentially zero.

The first array behind the windward array (2nd array) experiences considerably lower mean pressures than the first array but the rms pressures caused by the array induced wind turbulence are greatly increased. This is caused primarily by the turbulence created in the wind by the first array. In addition, the pressure distribution on the second array is significantly changed by the effects from the first array, especially when the wind is from the front. For this wind condition, the pressures on the windward array face become negative over a portion of the chord for several tilt angles, and ΔC_p may be negative over part of the chord for several tilt angles as shown for the 35° tilt angle case. In this condition, if only normal forces were recorded on the array, they would indicate essentially zero force. From the pressure coefficient distribution shown in Figure 4-1c to 4-1f, it can be seen that there are varying pressures on the array and a significant pitching moment is felt by the array.

The loads on the fifth array downwind from the edge of the array field experience larger fluctuating pressure coefficients than the first array, but smaller than the second array. Although the fluctuating pressure coefficients are of the same order as the steady state pressures on the fifth array, the total of these pressures is much smaller than only the steady state pressures on the first array. Another noteworthy aspect of the loads on the fifth array is the flatness of the pressure distribution along the chord. The pressure distribution is essentially constant over the chord for each tilt angle considered. An exception is the 20° tilt angle configuration with the wind approaching the array from the back, where the pressure distribution along the chord linearly increases from the trailing edge to the leading edge.

4.2 1/7 Power Law Wind Velocity Profile

The major portion of the wind tunnel test program was devoted to the wind loading on the arrays in a boundary layer wind of 1/7 power law velocity profile shown in Figure 4-2. This section presents and discusses the significant findings of the wind tunnel test results performed in the boundary layer wind. The array test configuration, pressure measurement locations and wind direction are given in Table 4.1.

Table 4-1. Array Test Conditions

Array Configuration (Tilt Angle)	Fence	Pressure Measurement Location	Wind Direction
20°, 35°, 60°, 90°	No	Center of Span	0° (Head-On), 180°
20°, 35°, 60°, 90°	Yes	Center of Span	0° (Head-On), 180°
35°	No	Edge of Span	0° (Head-On), 180°
35°	Yes	Edge of Span	0° (Head-On), 180°
35°	No	Edge of Span	45°, 225°
35°	Yes	Edge of Span	45°, 225°

4.2.1 Array Mid-Span Wind Loads Without a Protective Wind Barrier (Fence)

Figure 4-3 presents the mean and rms delta pressure coefficient distributions on the arrays in an array field with an identical configuration as in Figure 4-1, except for the wind profile. The pressure coefficients are based on the freestream reference velocity located at a height of ten meters. The results for the mean and rms ΔC_p chordwise distributions are very similar in shape to those from the uniform wind profile test results presented in Section 4.1. Because the magnitude of the coefficients are a function of the reference velocity that varies with elevation above the ground in a boundary layer wind, a direct magnitude comparison with the uniform flow results cannot be made with the boundary layer results referenced to the freestream velocity at 10 meters. The trends of the results plotted in Figure 4-3 are the same as those for the uniform velocity profile results shown in Figure 4-1. That is, the highest

steady state or mean pressures are on the first array. The downwind arrays have lower steady state pressure than the front array because of the protection afforded by the upwind arrays, but the rms pressures are slightly higher within the array field than for the front array. In addition, with increasing tilt angle, the greater the amount of protection from the wind is received by the downwind arrays from the upwind arrays.

The effect that the upwind arrays have on reducing the resulting forces on downwind arrays is shown by examining the normal force coefficients presented in Figure 4-4. The normal force coefficients were obtained by integrating the delta pressure coefficients along the chord for each array and array configuration for the steady state wind. The maximum normal force coefficient on the array is due to a wind from the rear and on the first windward array for all tilt angles. Regardless of the wind direction, the first windward array acts as a barrier to the wind for the downwind arrays and removes most of the wind energy. Consequently, the steady state wind load on the second array is significantly reduced, and the steady state wind load on succeeding arrays beyond the second array are only slightly reduced from that of the second array.

4.2.2 Array Mid-Span Loads with a Protective Wind Barrier (Fence)

The protective influence on the high aspect ratio photovoltaic arrays by a fence is presented in Figure 4-5 and 4-6. Figure 4-5 shows the ΔC_p on the first array behind a six foot fence (.75C). The corresponding normal force coefficients for the first, second and fifth arrays are shown in Figure 4-6, with the results without a fence for comparison. With a fence to protect the arrays from the wind, the wind-caused normal force coefficients are approximately the same on the first and succeeding arrays except for the arrays with tilt angles of 60° . The top of the array at a tilt angle of 60° is approximately .375 chord lengths above the top of the fence, so the upper portion of the first array is exposed to the freestream velocity resulting in increased loads. Of significant conclusion from Figure 4-6 is that the normal force on arrays several rows into the array field are the same with or without a fence. Thus, the fence only protects the first couple of rows of arrays and the remaining arrays are protected by the windward arrays.

4.2.3 Array Edge Wind Loads for Straight-On Winds

Figure 4-7 and 4-8 presents the pressure distribution at a location .15 chord lengths from the side edge for arrays having a tilt angle of 35° and for an array field without and with a protective fence respectively. Figures 4-9 and 4-10 show the normal force coefficients for the same conditions and compare the normal force coefficients at the array edge location to the mid-span location. Figure 10 of the Appendix A shows the location of the edge and center of span pressure taps on the model used in the test.) Without a fence to protect the arrays, the first windward array pressure distribution at the edge is essentially the same as at the center of the array (compare Figure 4-7 to Figure 4-3c and d). The arrays downwind from the first array have an edge pressure coefficient distribution whose magnitude is reduced from the first array but not nearly as much as for the mid-span pressure coefficients at similar conditions. The edge pressures are affected by the formation of vortices resulting from the array corners. This can be seen by the significant increase in the rms pressure coefficient levels between mid-span and edge locations and by the increased steady state pressure coefficient at the array corners, especially for winds approaching from the rear. The normal force coefficients shown in Figure 4-9 also show this trend.

The fence reduces the wind by such an amount that no large differences occur in pressure coefficient distributions at the edges compared to the mid-span pressure locations as seen by comparing Figure 4-8 to Figure 4-5 for identical array positions. One aspect of Figure 4-8 that is important is that the pressure coefficients for the fifth array downwind are larger than the first array. It is conceivable that the array edge pressures behind a protective fence will approach those without a protective fence for downward arrays when the wind is straight-on to the arrays. This results because the side fence has no effect on the straight-on wind and the fence perpendicular to the wind has a decreasing effect on the wind with increasing distance downwind from the fence. Extrapolating the normal force coefficients in Figure 4-10 further downwind supports this conclusion and suggests that loads on the arrays with a fence will approach those without a fence further downstream than five arrays.

4.2.4 Array Edge Wind Loads for Oblique Winds

Downwind effects of vortices formed at the array corners can cause large pressure coefficients near the array edges when the winds are at an angle to the arrays, because of increased vortex strength. Several wind tunnel test runs were performed with oblique winds at 45° approaching the arrays from the front and the rear directions. The array configurations were: tilt angle of 35° , array separation = $2C$ and array ground clearance = $.25C$. Large local pressures on the array edges due to oblique winds were measured as shown by the pressure coefficient distributions located $.15$ chord lengths from the array edge in Figures 4-11, a through d, for an array field without and with a protective fence.

The leading edge pressure coefficients, especially for unobstructed winds approaching from the front, were very large and can result in pressures at the leading edge approaching 45 psf for a 90 mph wind, based on the pressure coefficients in Figures 4-11a and 4-11b. When no fence exists, the array edges for arrays downwind from the first array do not receive any protection from the upwind arrays; therefore, their edge pressure distribution is essentially the same as the first array, as shown in Figures 4-11a and b. Figure 4-11a also shows the pressure distribution located $.9$ chord lengths from the edge on the first array. The trend implies that the magnitude of the pressure coefficients are decreasing with distance away from the side edge.

Even when the arrays are protected by a fence, the edge pressure coefficients due to an oblique wind are much larger than for straight-on winds as shown by comparing Figures 4-11c and d to Figure 4-8. The fence does give some protection to the arrays because the overall array edge pressure coefficient distribution is somewhat lower in magnitude than the corresponding conditions without a fence. This can be seen more easily by comparing the normal force coefficients at the edge with and without a fence as shown in Figure 4-12. Figure 4-12 also shows the reduction in normal force coefficients from $.15$ chord lengths to $.9$ chord lengths from the edge with and without a fence. The combination of a fence corner and an oblique wind causes a strong vortex to be generated at the fence corner which sweeps downwind and causes localized high pressure loadings. The high pressure loading caused by this vortex can be seen by the twin large humps in the pressure coefficient distribution shown on the first array in Figure 4-11c and by the large pressure coefficients at the

leading edge in Figure 4-11d. Figures 4-12 and 4-13 also show the effect of the vortex. Although the normal force coefficient for an array behind a fence is lower than without a fence (Figure 4-12), the corresponding maximum pressure coefficient is higher (Figure 4-13) on the first windward array when the wind approaches from the rear. This maximum pressure coefficient is at the leading edge which is directly downwind and in the vortex from the fence.

Because of the high edge pressures on the arrays, several modified configurations were tested in the wind tunnel in an attempt to reduce these pressures. The modifications (described in more detail in the Appendix) are as follows:

- 1) A short fence of the same porosity and height as the protective fence placed in front of the corner of the protective fence and at 45° to each side. This short fence would be perpendicular to an oblique wind that is at 45° to the protective fence and array field (See Figure 4-16, Configuration 1)
- 2) Three short fences overlapping each other and placed in front of the corner of the protective fence as in (1) (see Figure 4-16, Configuration 2)
- 3) Additional eight foot length added to the array with the added length having 50% porosity (See Figure 4-16, Configuration 3)
- 4) Endplating of the array ends completely closing the rows of the arrays with a 50% porosity end plate. This is to simulate shrubs etc., at the ends of the arrays (see Figure 4-16, Configuration 4)
- 5) Addition of a 50% porosity extension to the top of the array at the corner of the existing protective fence (see Figure 4-16, Configuration 5 and Figure 4-11g).

The data from the wind tunnel test for all of these configurations is given in Appendix B, and plots of the data are presented in Appendix C. The results from the configurations in (1) through (3) are not presented in the main body of the report for the following reasons. Configuration (3) did not produce any reduction in edge pressures. Configurations (1) and (2) did show reductions in the pressure coefficient distributions for the pressure taps on the model. However, this configuration would require more pressure readings over the total

array area near the edge to adequately define this reduction. It is believed, and somewhat supported by the data, that the vortex caused by the main fence corner is significantly reduced, but that other vortices are being generated at the corners of the smaller fences, thus pushing the location of the high pressure loading points inwards from the array side edge.

Configuration (4), endplating of the arrays, produced the smallest edge pressure coefficients of the configurations tested. The edge pressure coefficient distributions for the endplating effect is shown in Figures 4-11e and f. Unfortunately, this method of reducing the loads may be impractical for several reasons: (1) the endplating would cause varying amounts of shadowing on the arrays depending upon the time of day, (2) if mechanized equipment is required to be moved down each row of the arrays, a gate would be required at the end of each row.

The addition of a 50% porosity extension to the fence corner is shown with the results in Figures 4-11g and h. This extension does significantly reduce the edge pressure coefficient distributions from those of just a regular protective fence. It appears that the increased porosity and height at the corner reduces the tightness and strength of the corner vortex. Additional benefits may be realized by increased porosity and/or height of this corner addition. However, these parameters were not varied to optimize the reduction in the array edge pressure loadings.

In summary, the array and fence corners produce vortices whose strength is increased from a straight on wind to an oblique wind. The wind loads on the areas affected by the corner vortices are considerably larger than the loads at the non-affected areas. In order to reduce the corner vortex induced loads, it is necessary to reduce the strength of the corner vortex. This is best accomplished by lowering the wind velocity prior to reaching the arrays by utilizing a fence and by modifying the fence corner to reduce the vortex generated by it. From the modifications investigated in the test, the most practical modification is that of increasing the height of the fence at the corner and by varying the local fence porosity in this area as shown by the figure insert in Figure 4-11g.

4.3 Comparison of Wind Tunnel Test Results for Uniform Wind Profile and 1/7 Power Law Wind Profile

In order to compare the test results between the uniform wind profile and the 1/7 power law wind profile, it is necessary to select a reference height above the ground for defining the reference velocity in the 1/7 power law wind profile. In Phase II, reference 5, the velocity at the highest edge of the array was recommended as the reference velocity when using data obtained by a uniform velocity profile because the base pressure (the major contribution to total pressure in most cases) is affected predominately by the velocity at the array edge. The mean ΔC_p was calculated with this reference velocity for the 1/7 power law wind profile results and compared in Figure 4-14 to the ΔC_p obtained by the uniform wind profile test. The comparison of the shape of the ΔC_p distribution from the two wind profile tests is very close, the magnitude is also close except for a few configurations, such as the windward array with the wind from the rear for the 20° tilt angle configuration and the wind from the front for the 60° tilt angle configuration, where the magnitudes differ by as much as .25. The second array with a tilt angle of 35° and the wind from the rear also compares poorly; the loads from the 1/7 power law wind profile are approximately half the loads from the uniform wind profile.

Integration of the ΔC_p values over the chord to obtain normal force coefficients produced the results presented in Figure 4-15. The comparison of the normal force coefficients between the uniform wind profile and the 1/7 power law wind profile is much closer than the pressure distribution, primarily because the integration of large pressure differences over a small fraction of the total area does not have a pronounced effect on the total normal force coefficient.

From the results shown in Figure 4-14 and 4-15, the uniform velocity profile normal force coefficients results would be satisfactory for use in performing preliminary design studies and in most cases for use in the final design of array structural supports. The pressure coefficient distribution results are not as definitive; the uniform velocity profile results would be satisfactory for use in preliminary design studies but are probably not accurate enough for final design of the photovoltaic panels. However, from the results, it is certainly apparent that a uniform velocity wind tunnel can be used to evaluate parameter studies for photovoltaic arrays such as load alleviation devices.

Since environmental wind tunnels (required to model the boundary layer wind) are few in number, and sometimes difficult to obtain time in their use, the close comparison in the results between the two wind profiles is important in allowing more flexibility in the testing of array models and configuration changes.

4.4 Test Results Summary

The use of a fence to protect the arrays from the wind significantly reduces the mid-span loads on the first windward array compared to the loads on an unprotected first array. The arrays located downwind from the first array are protected by the upwind arrays and the mid-span loads are approximately the same as the first array when protected by a fence. Localized array edge loads, caused by corner vortices, are considerably larger than the array mid-span loads. These edge loads can be reduced by using a fence to protect the arrays and by appropriate modifications to the fence corners shown previously in this section. To optimize the fence corner modifications or other modifications to the arrays for minimum wind loads would require an extensive test program. Since the large wind loads are a localized effect caused by the corner vortices, the arrays could be designed for higher strength in the edge areas to withstand the high vortex induced loads.

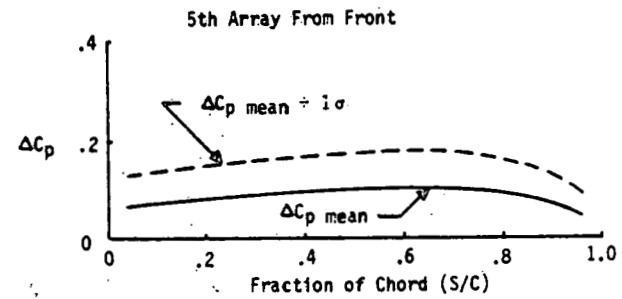
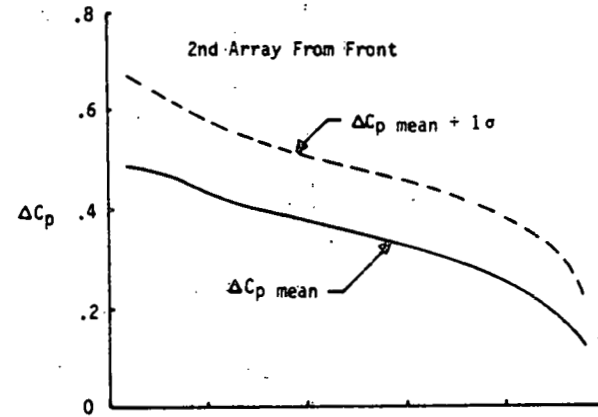
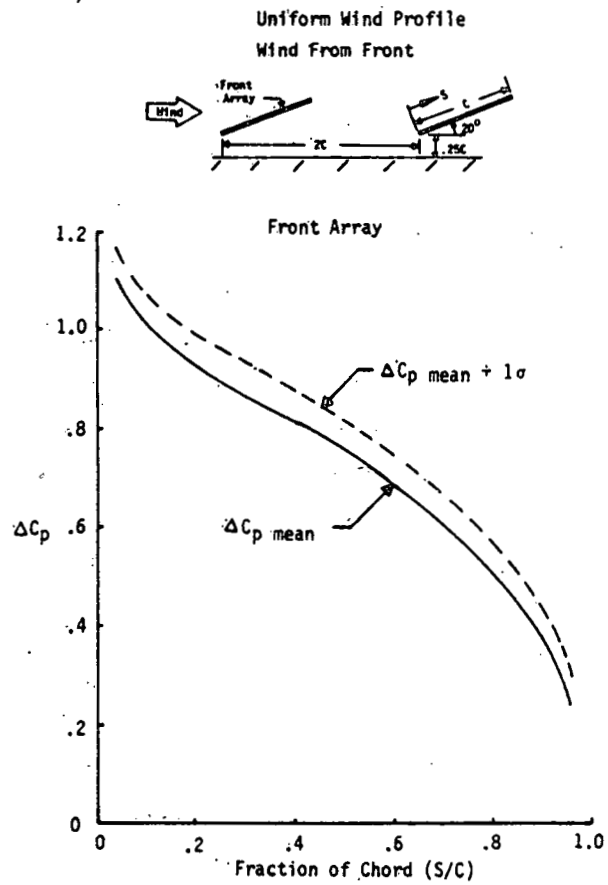

Figure 4-1a. Array Chordwise Pressure Coefficient Distribution in Uniform Wind Velocity Profile (Tilt Angle = 20° , Wind from Front).

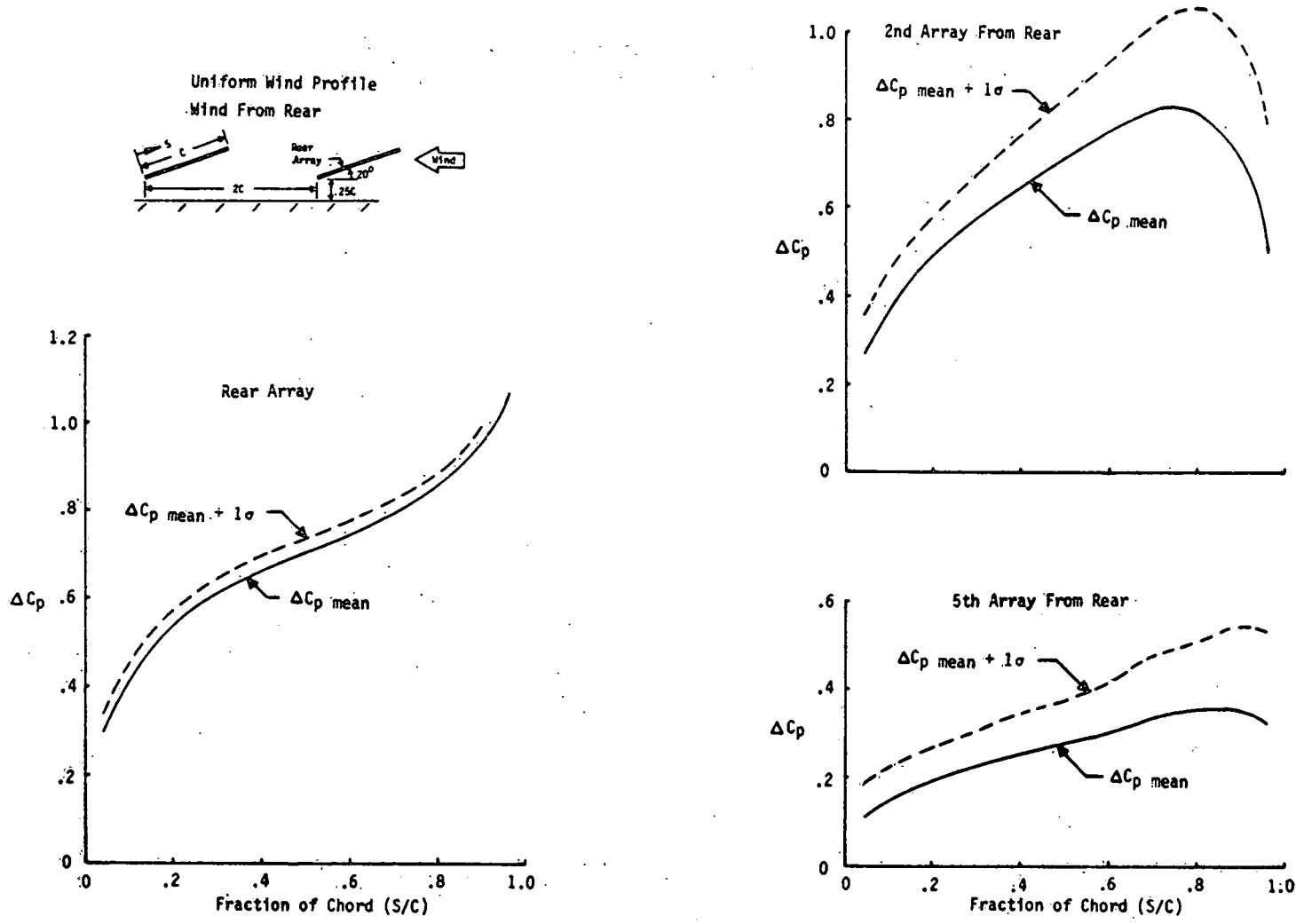

Figure 4-1b. Array Chordwise Pressure Coefficient Distribution in Uniform Wind Velocity Profile (Tilt Angle = 20° , Wind from Rear)

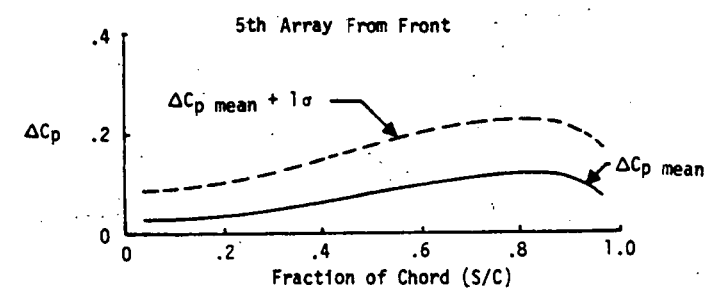
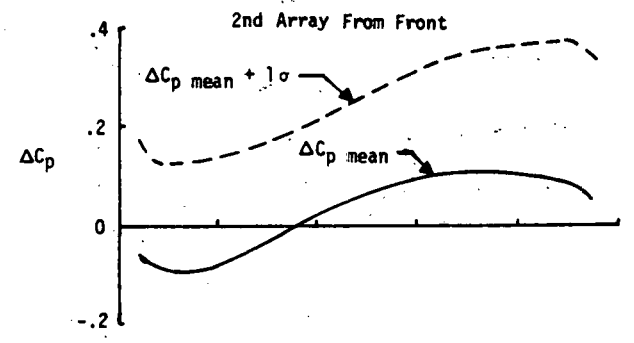
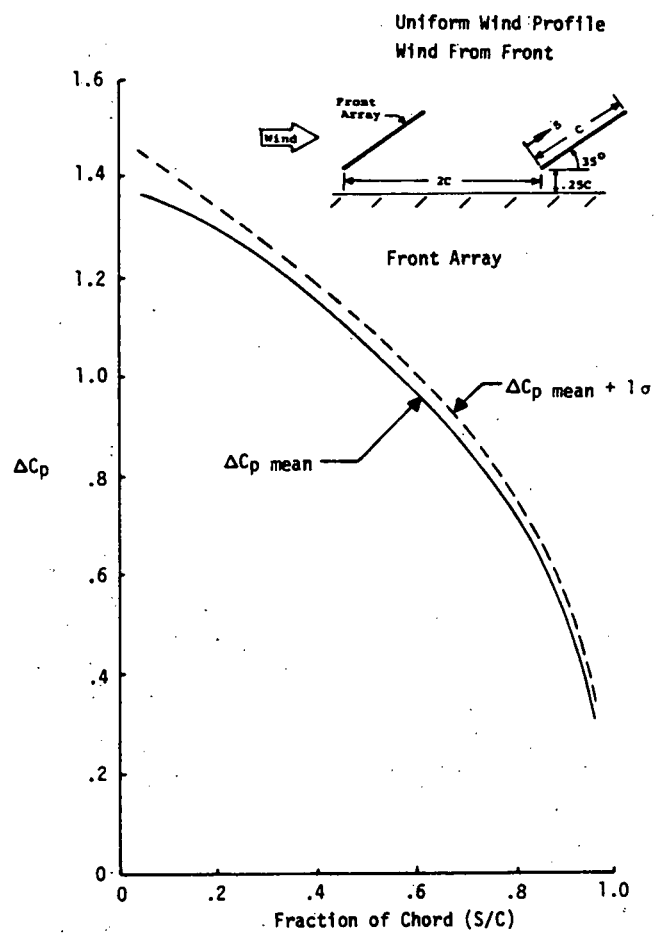

Figure 4-1c. Array Chordwise Pressure Coefficient Distribution in Uniform Wind Velocity Profile (Tilt Angle = 35°, Wind from Front)

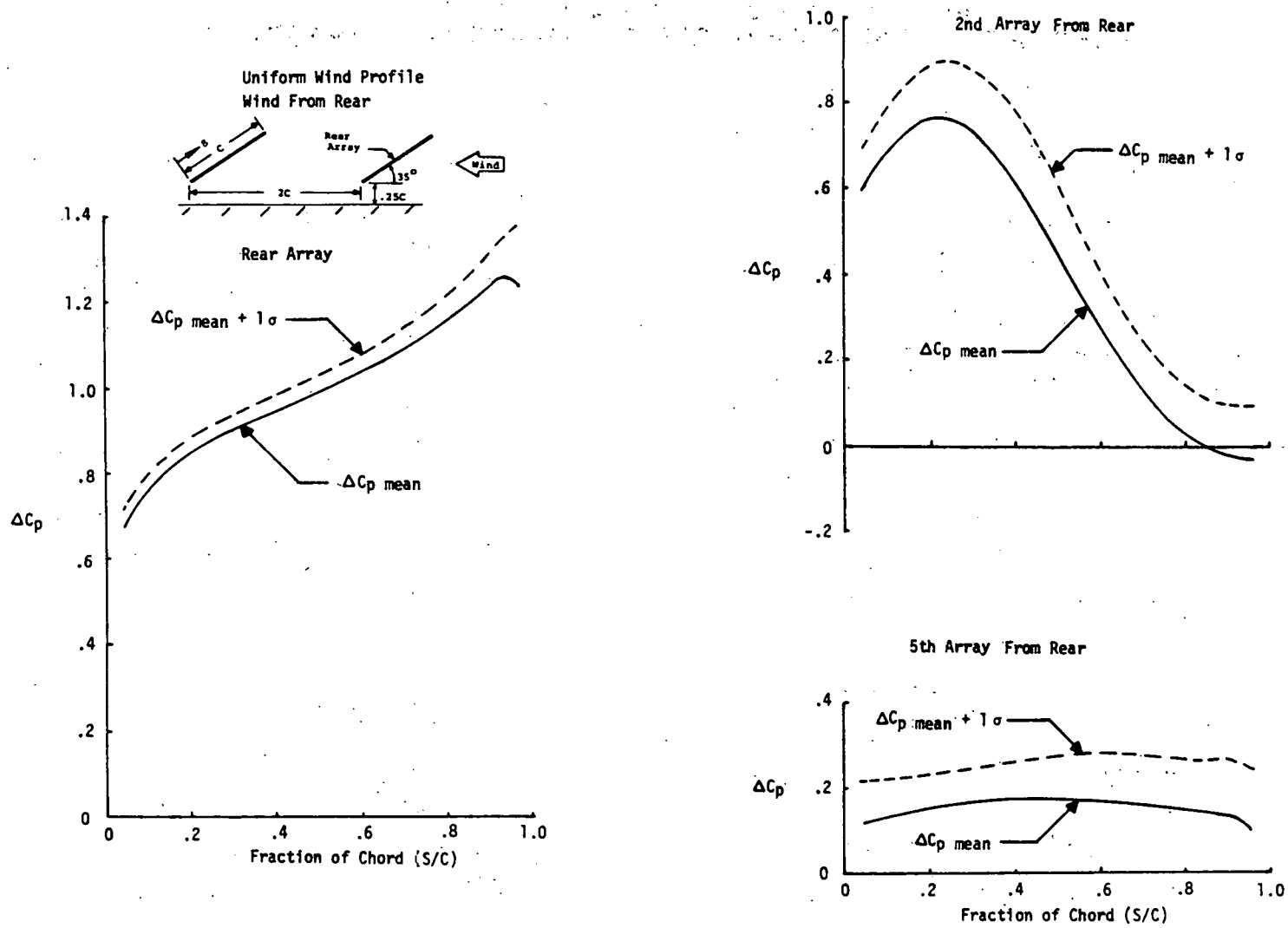

Figure 4-1d. Array Chordwise Pressure Coefficient Distribution in Uniform Wind Velocity Profile (Tilt Angle = 35°, Wind from Rear)

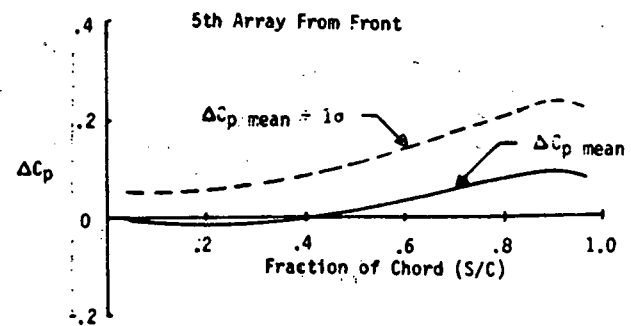
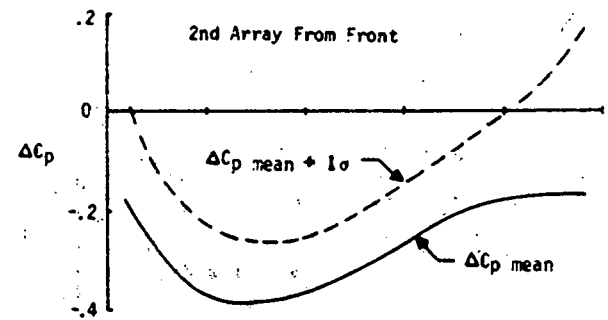
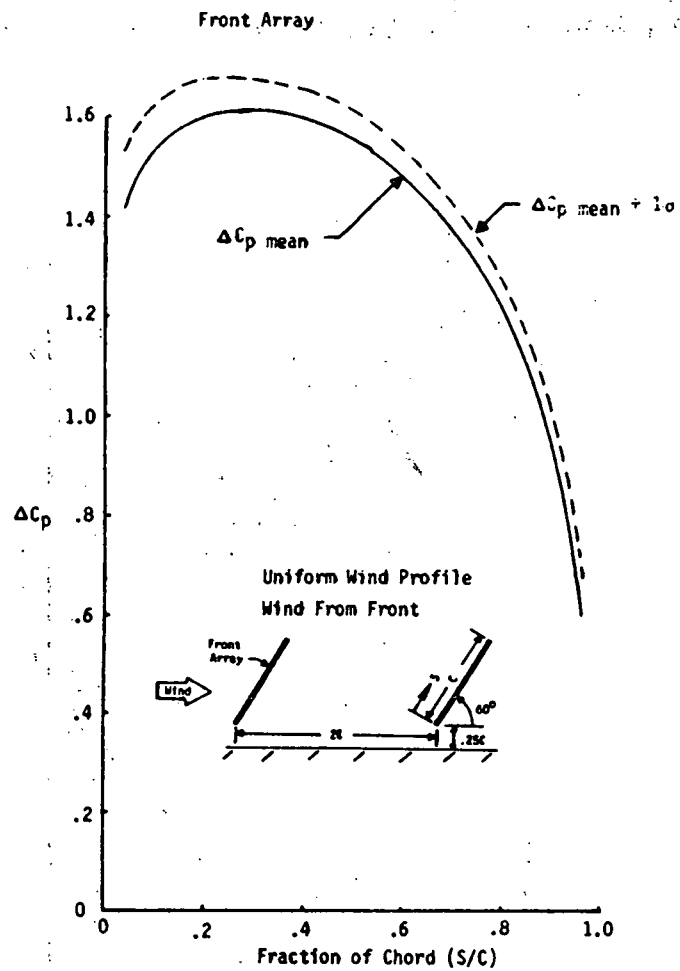

Figure 4-1e. Array Chordwise Pressure Coefficient Distribution in Uniform Wind Velocity Profile (Tilt Angle = 60°, Wind from Front)

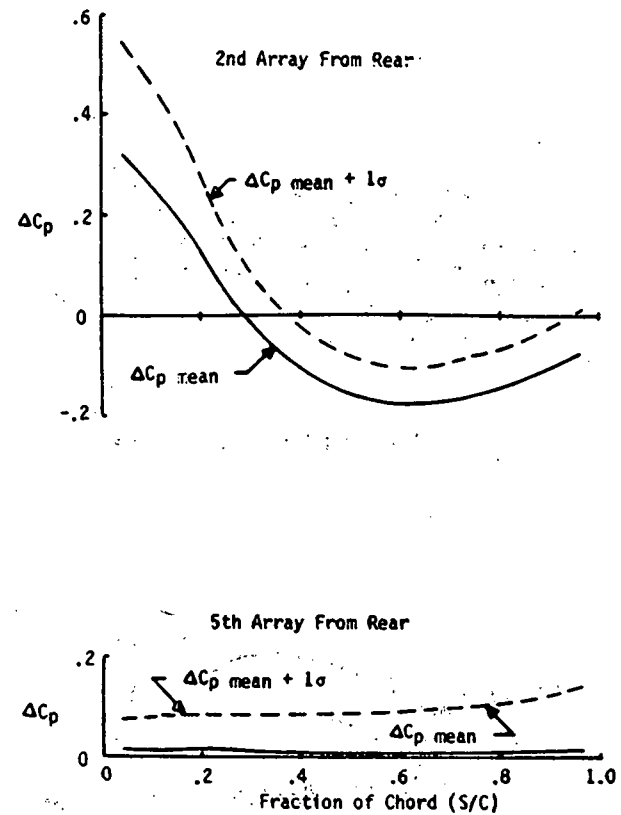
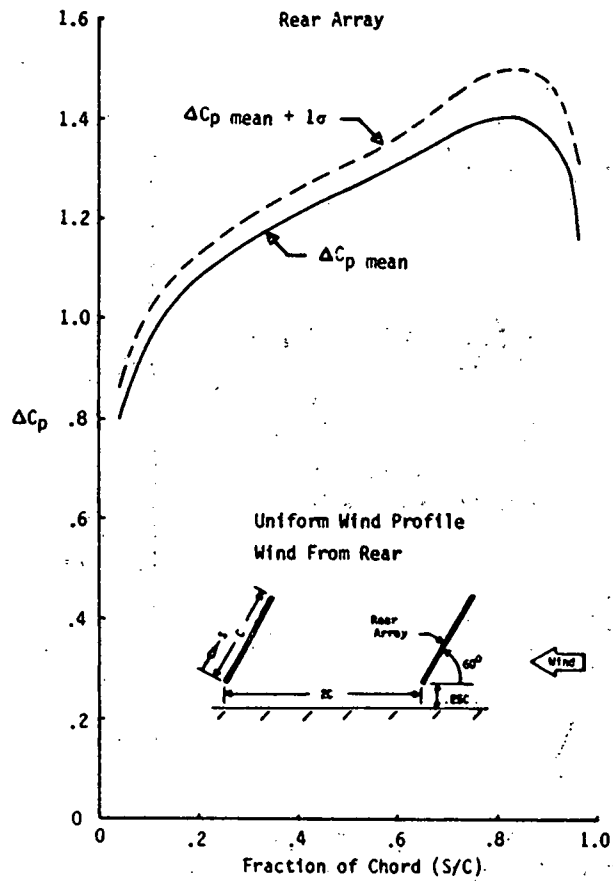

Figure 4-1f. Array Chordwise Pressure Coefficient Distribution in Uniform Wind Velocity Profile (Tilt Angle = 60° , Wind from Rear)

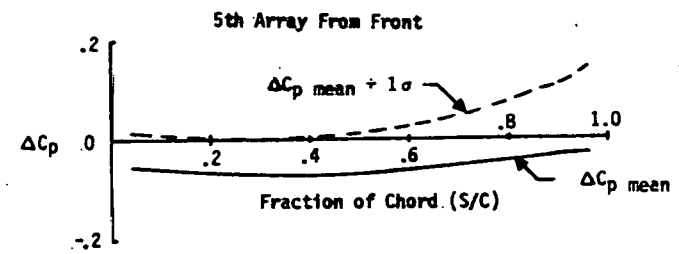
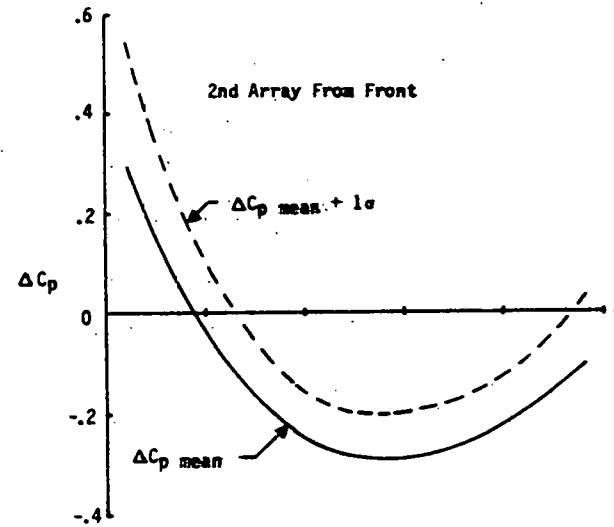
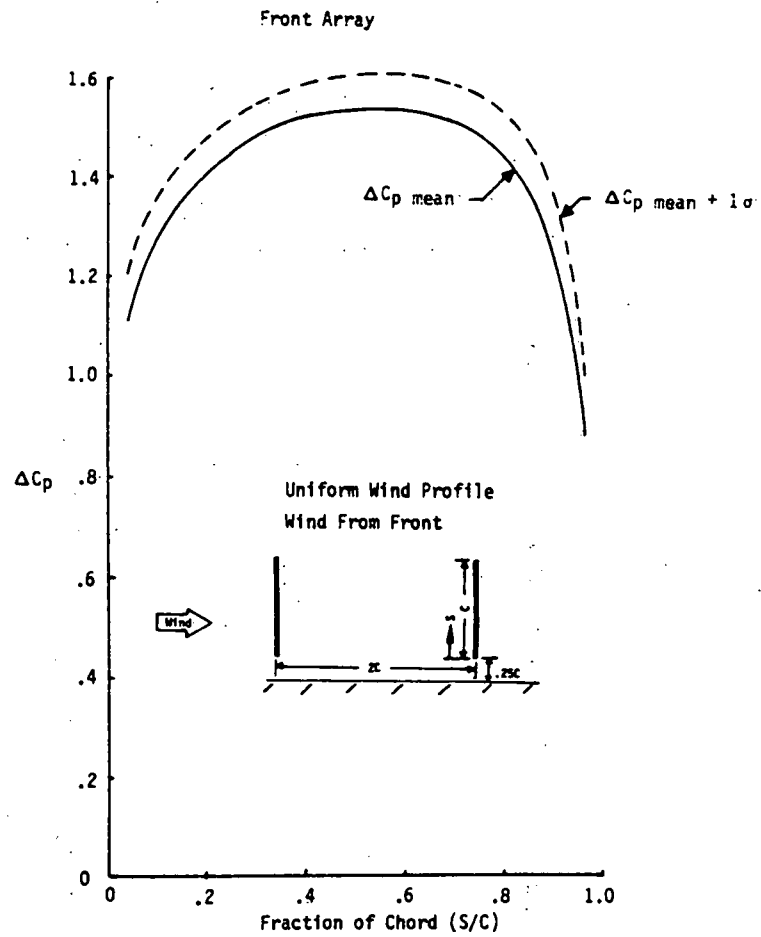

Figure 4-1g. Array Chordwise Pressure Coefficient Distribution in Uniform Wind Velocity Profile (Tilt Angle = 90°)

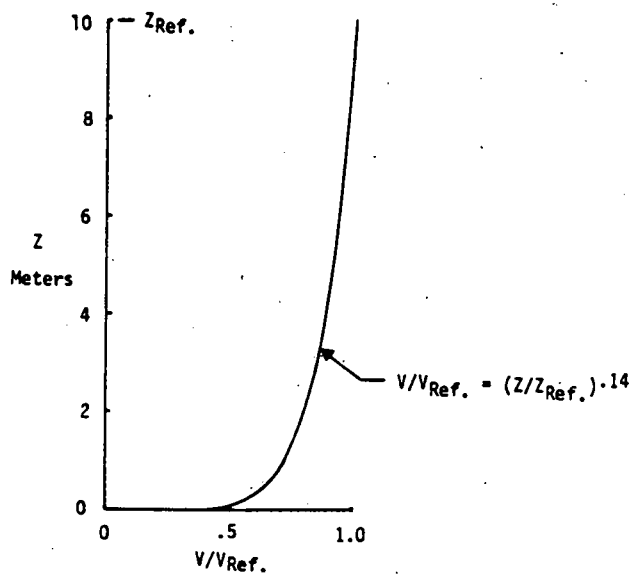

Figure 4-2. 1/7 Power Law Wind Velocity Profile

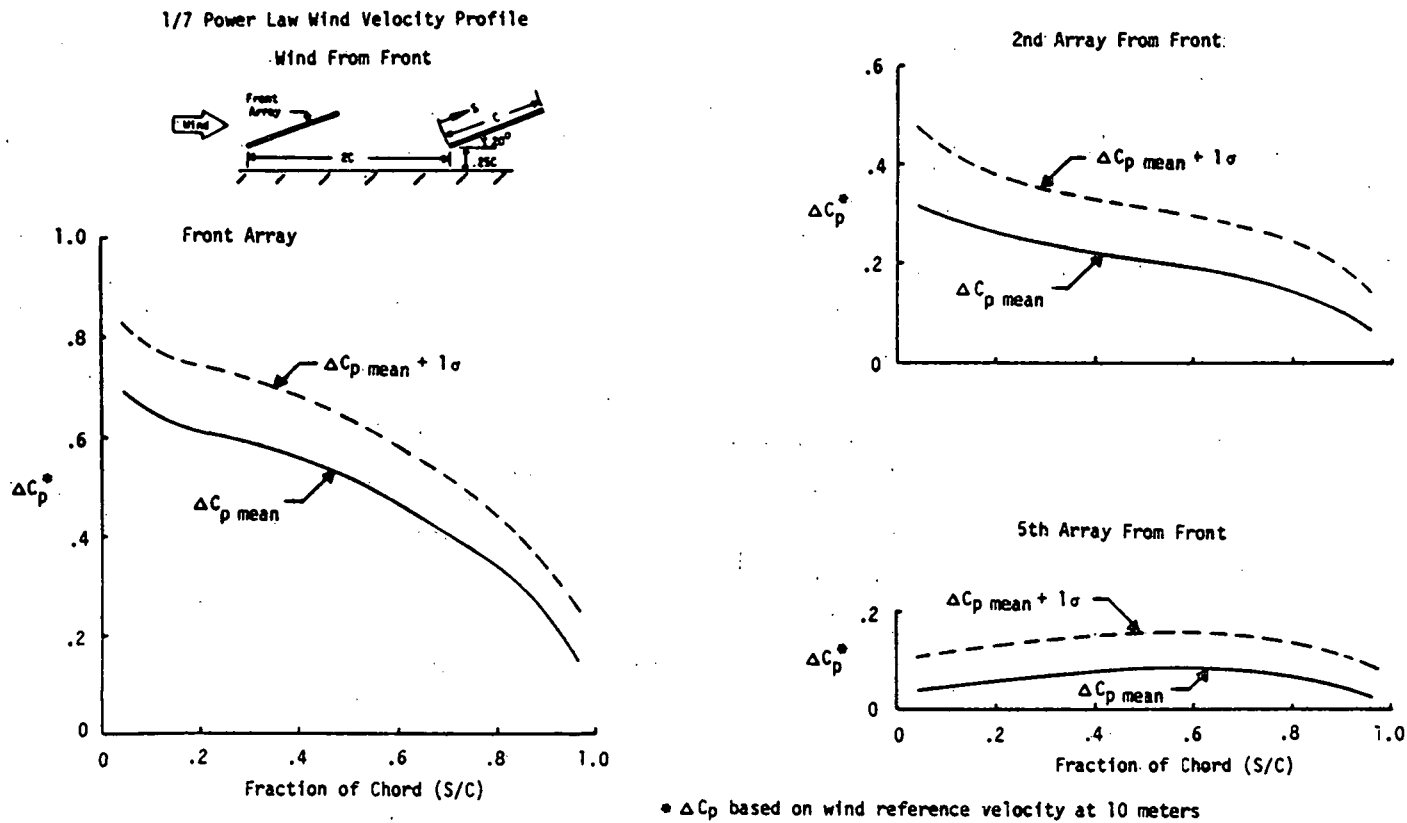

Figure 4-3a. Array Chordwise Pressure Coefficient Distribution in Boundary Layer Wind (Tilt Angle = 20°, Wind from Front)

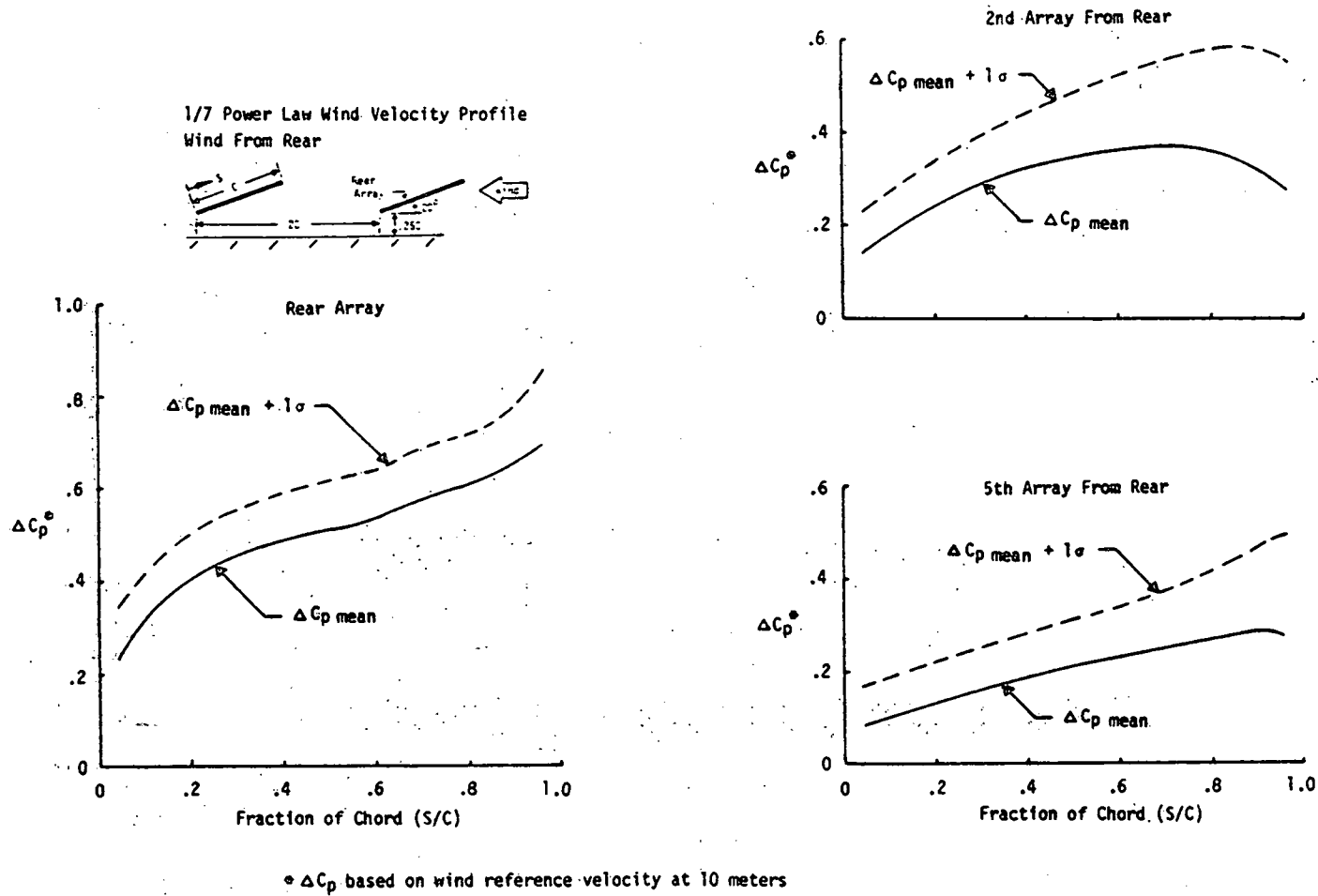

Figure 4-3b. Array Chordwise Pressure Coefficient Distribution In Boundary Layer Wind (Tilt Angle = 20° , Wind from Rear)

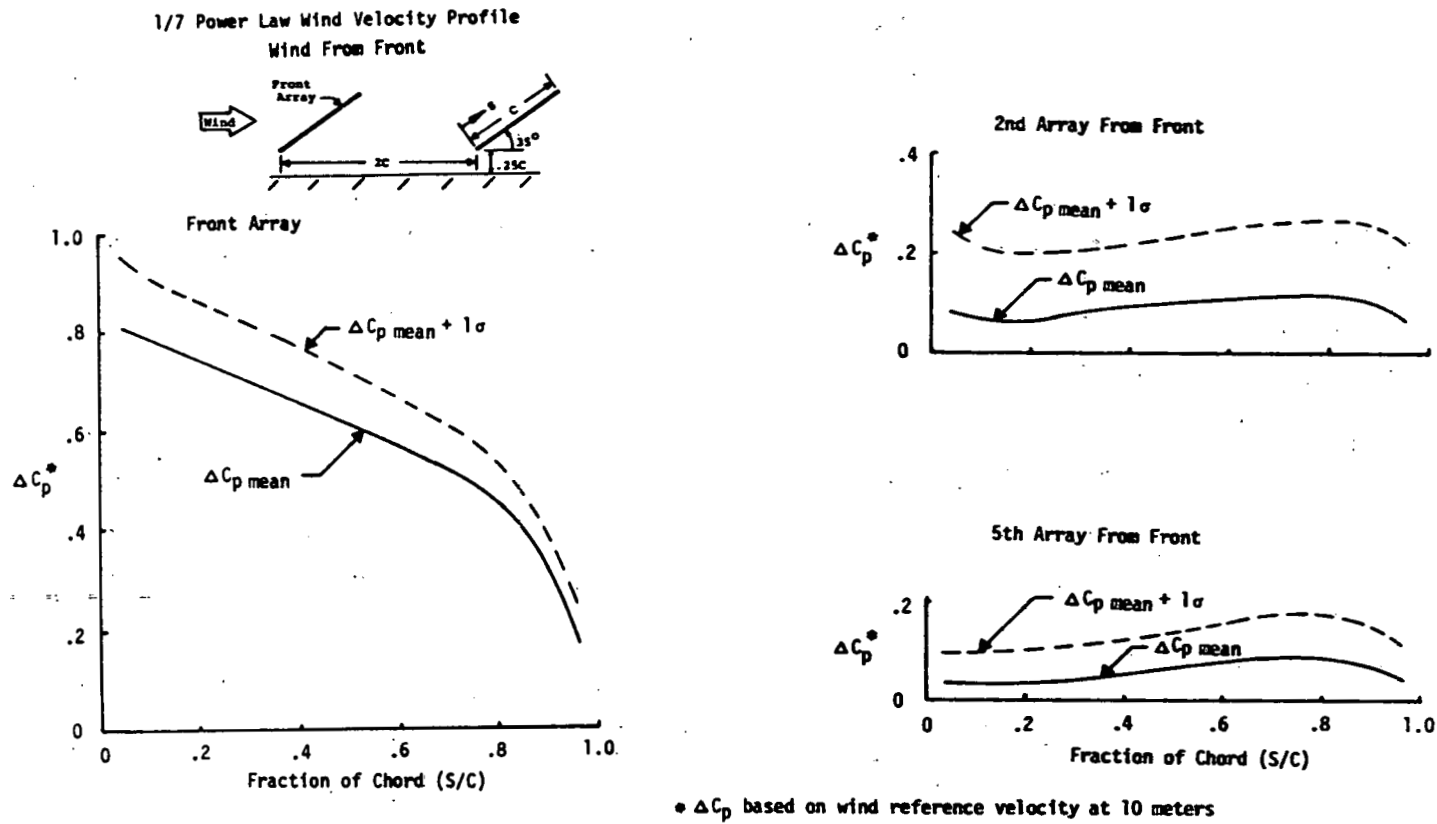

Figure 4-3c. Array Chordwise Pressure Coefficient Distribution in Boundary Layer Wind (Tilt Angle = 35° , Wind from Front)

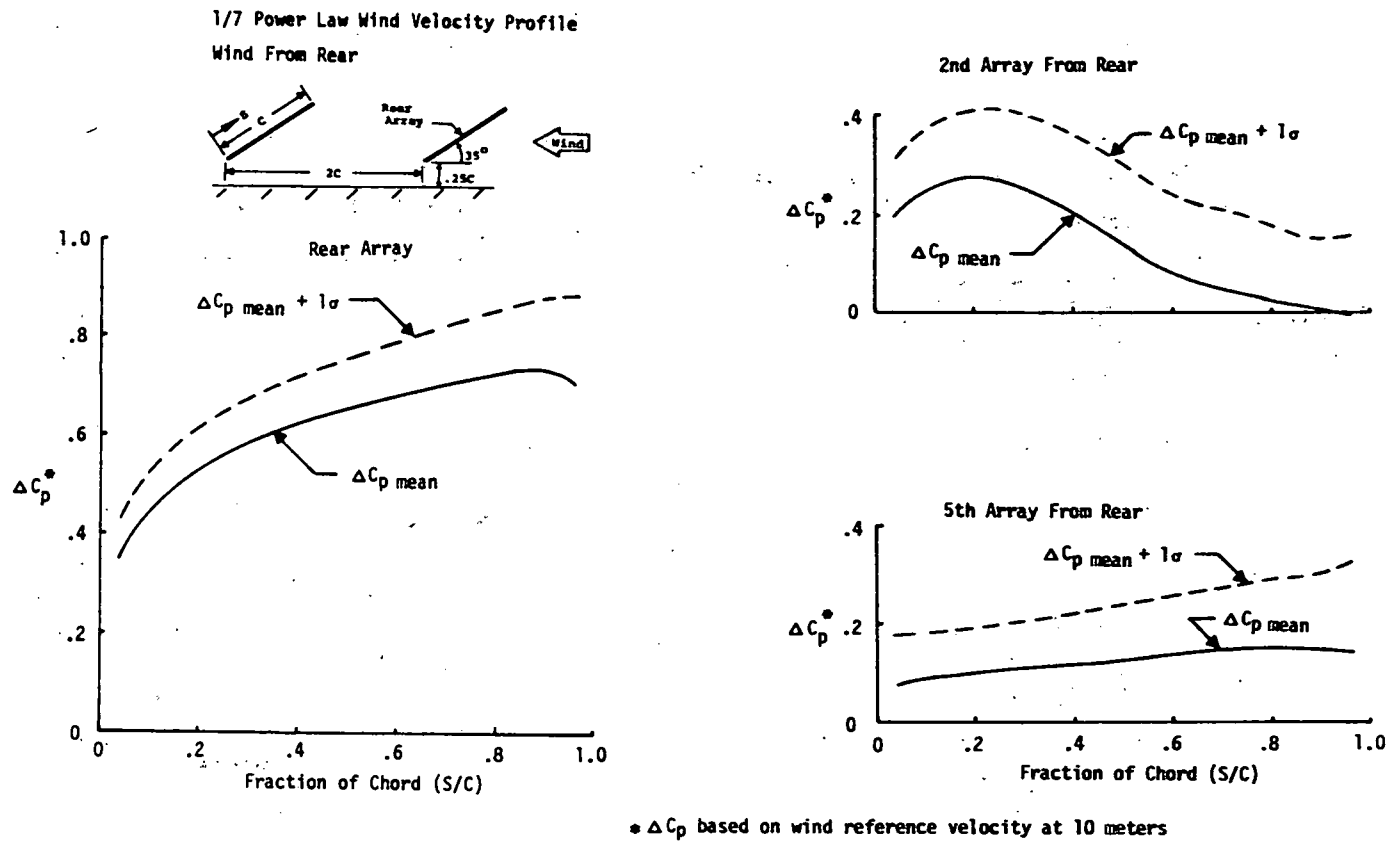

Figure 4-3d. Array Chordwise Pressure Coefficient Distribution in Boundary Layer Wind (Tilt Angle = 35° , Wind from Rear)

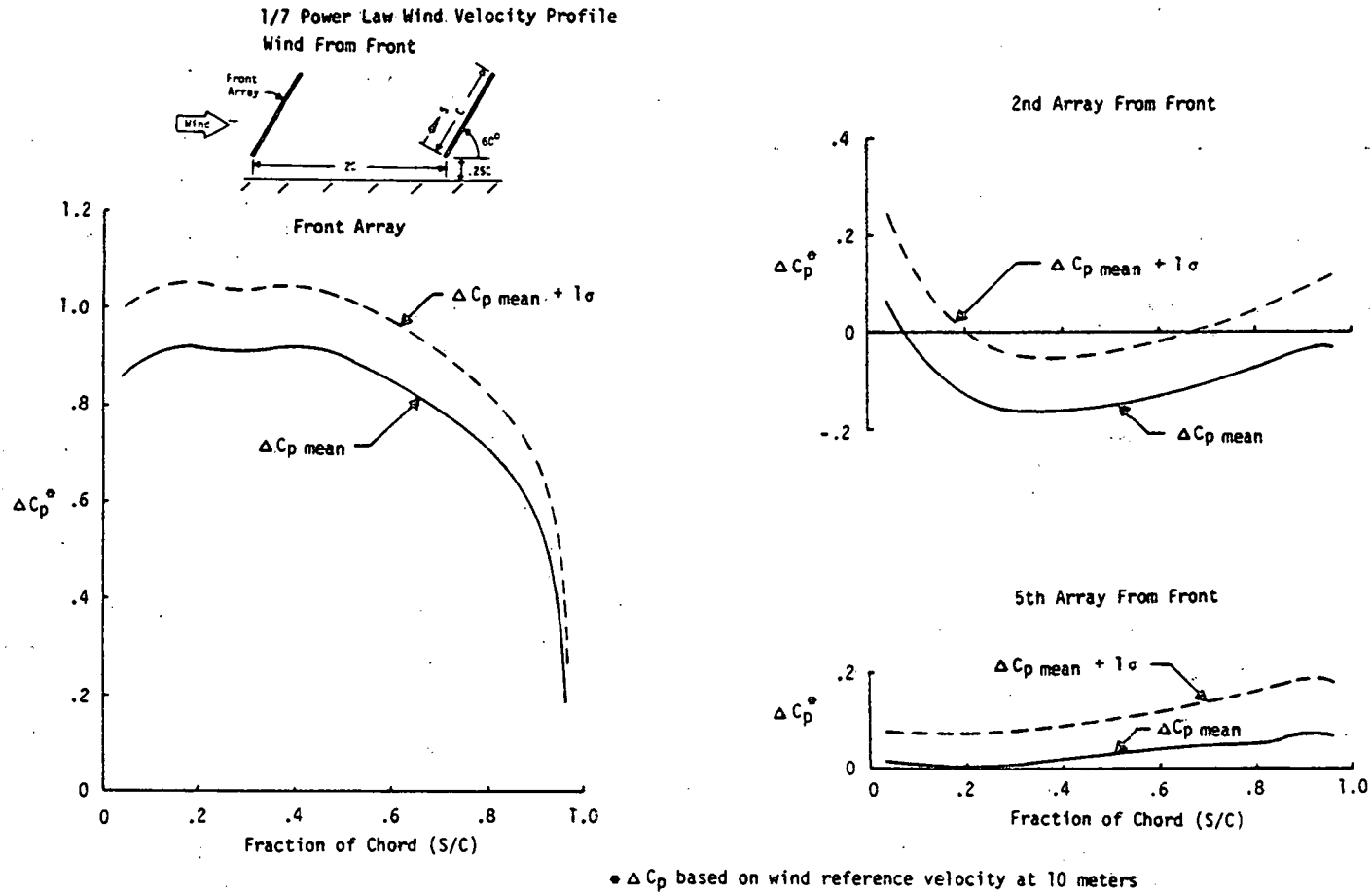
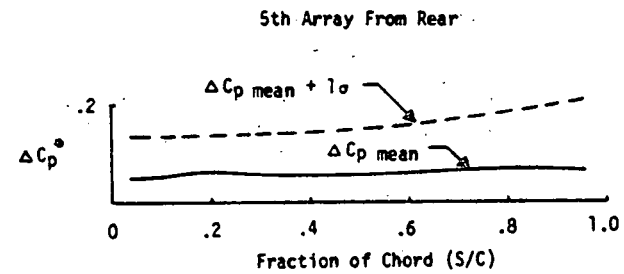
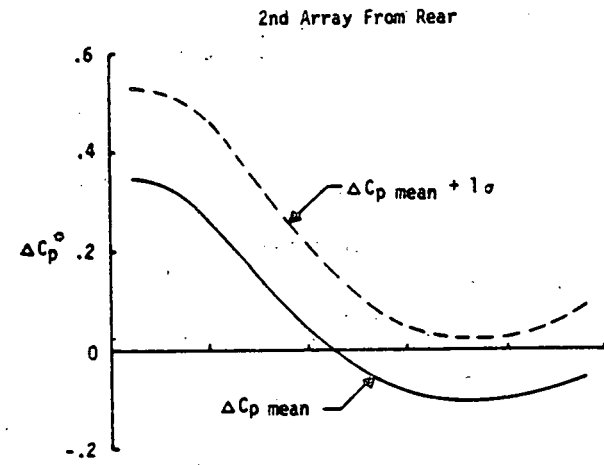
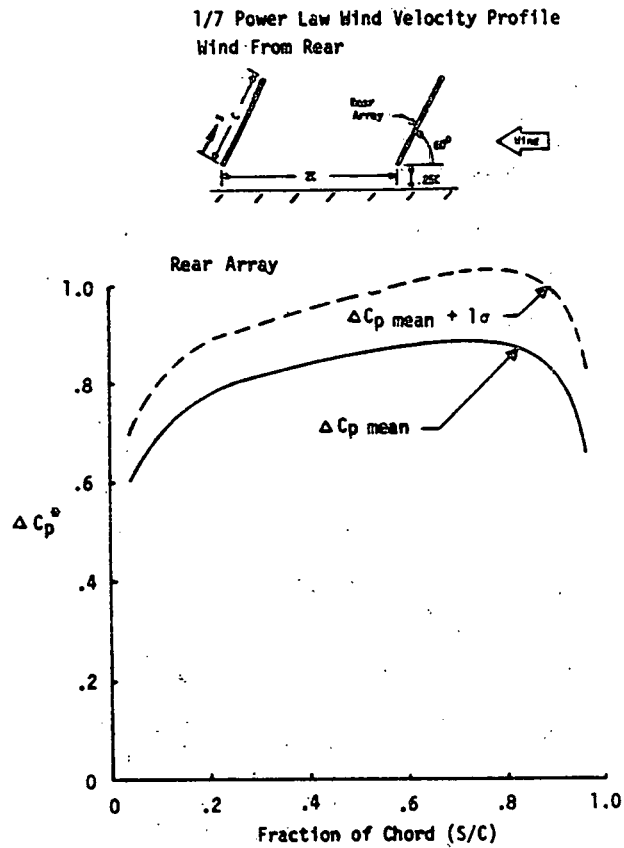
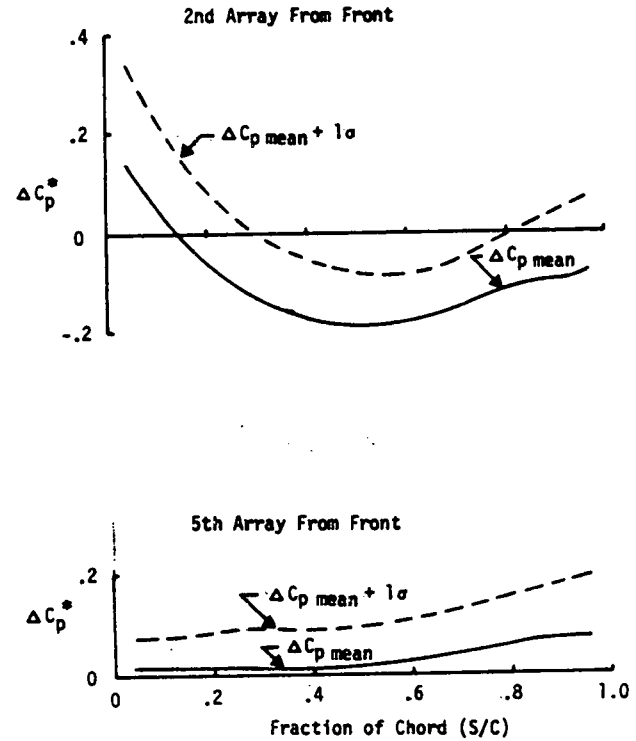
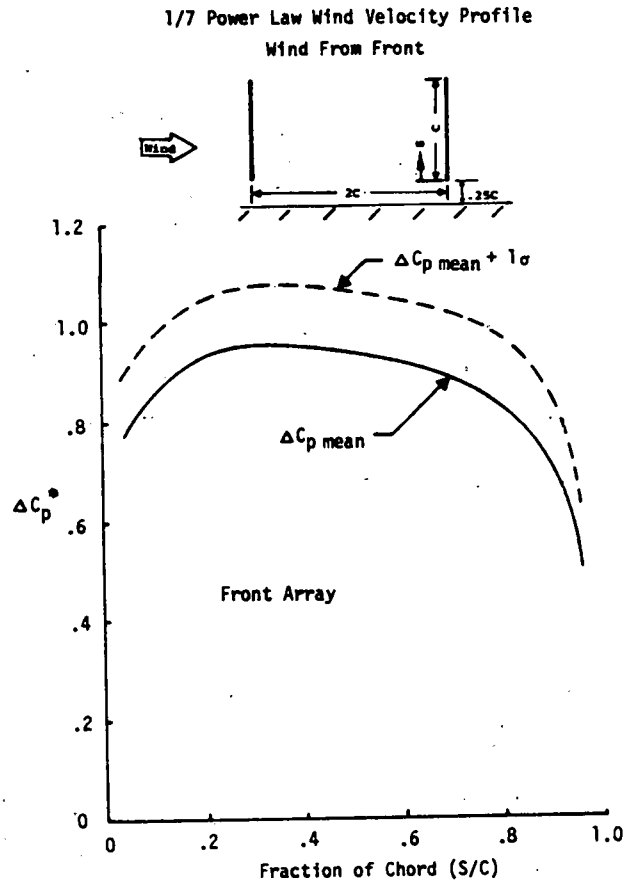

Figure 4-3e. Array Chordwise Pressure Coefficient Distribution in Boundary Layer Wind (Tilt Angle = 60° , Wind from Front)



• ΔC_p based on wind reference velocity at 10 meters

Figure 4-3f. Array Chordwise Pressure Coefficient Distribution in Boundary Layer Wind (Tilt Angle = 60° , Wind from Rear)



* ΔC_p based on wind reference velocity at 10 meters

Figure 4-3g. Array Chordwise Pressure Coefficient Distribution in Boundary Layer Wind (Tilt Angle = 90°)

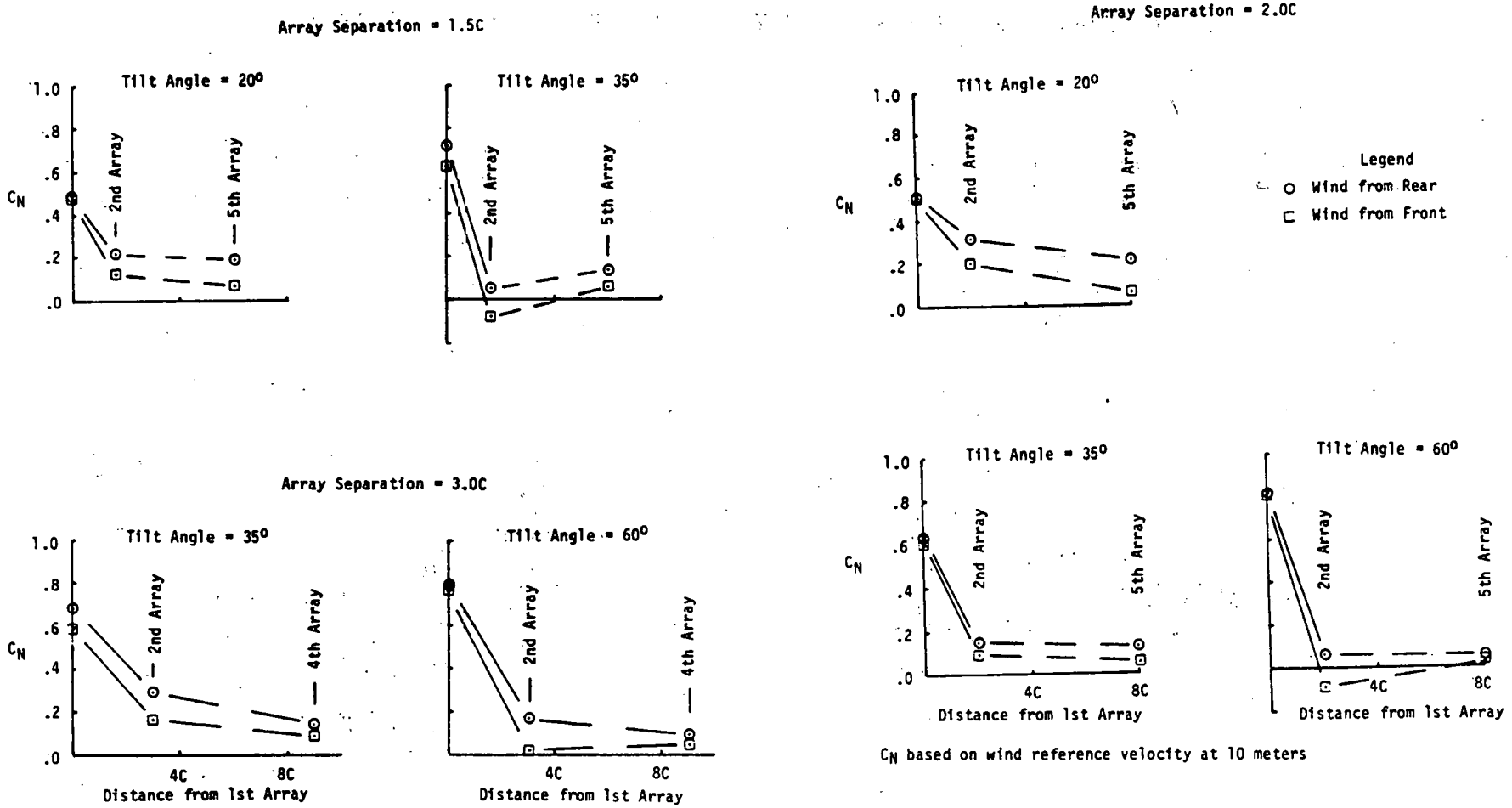
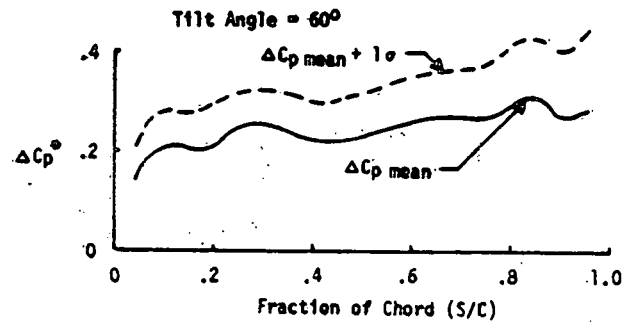
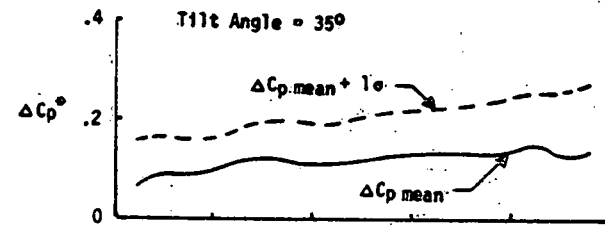
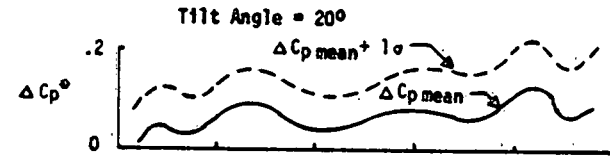
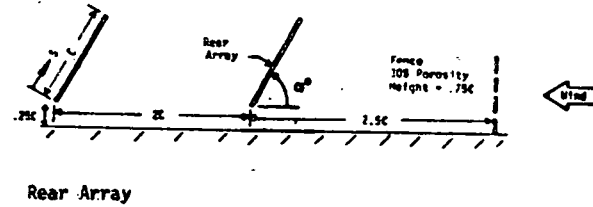
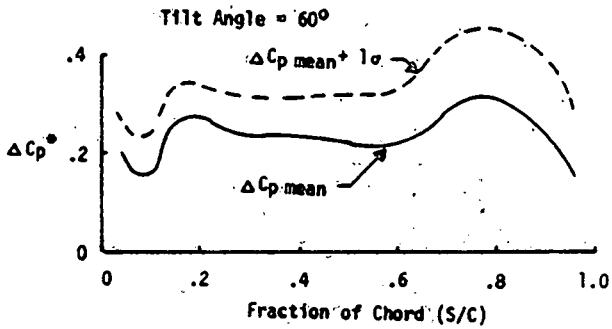
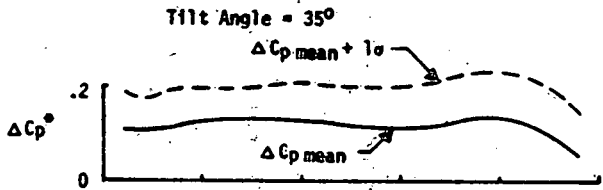
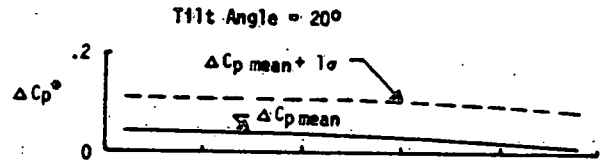
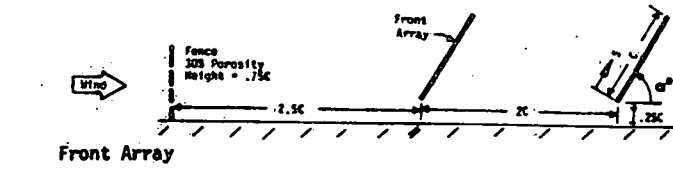

Figure 4-4. Effect of Head-On and Rearward Winds on Array Normal Force Coefficients (No Fence)

1/7 Power Law Wind Velocity Profile



• ΔCp based on wind reference velocity at 10 meters

Figure 4-5. Effect of a Fence on Array Chordwise Pressure Coefficient Distribution for Head-On and Rearward Winds.

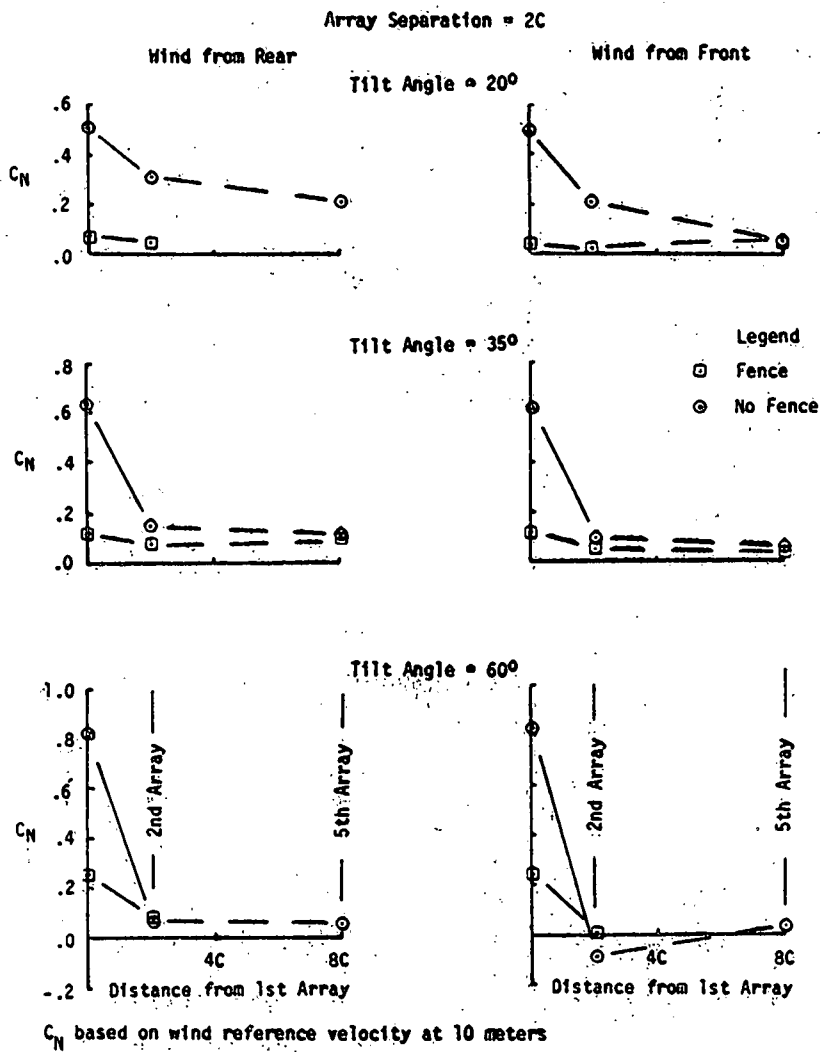

Figure 4-6. Effect of a Fence on Array Normal Force Coefficients for Head-On and Rearward Winds.

1/7 Power Law Wind Velocity Profile

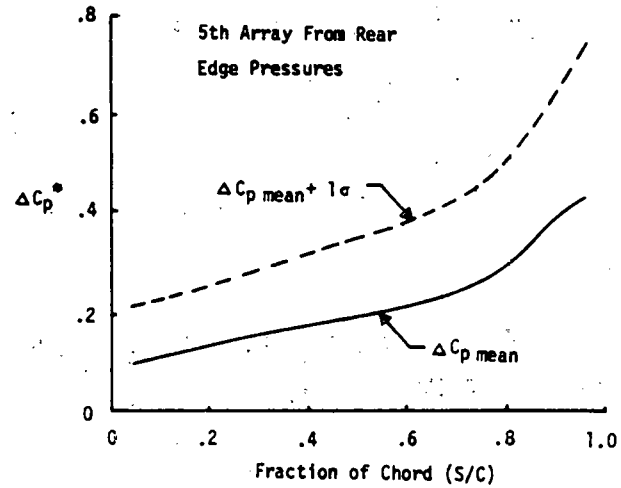
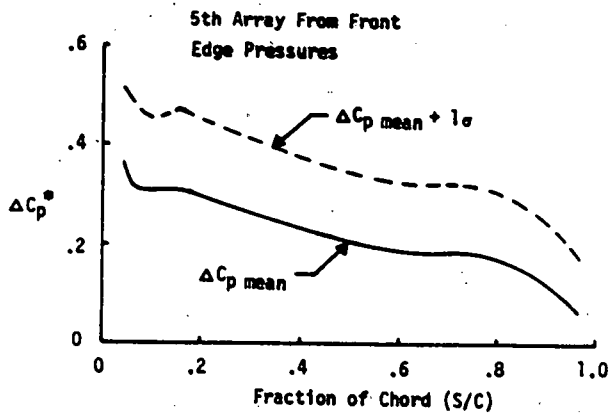
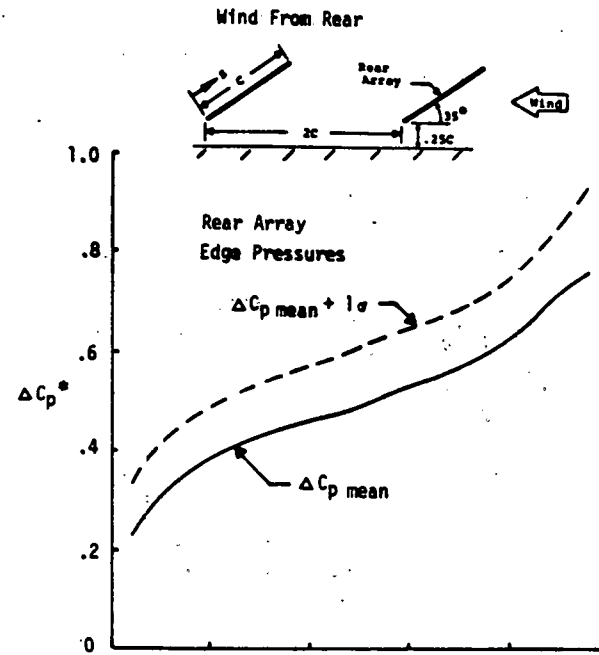
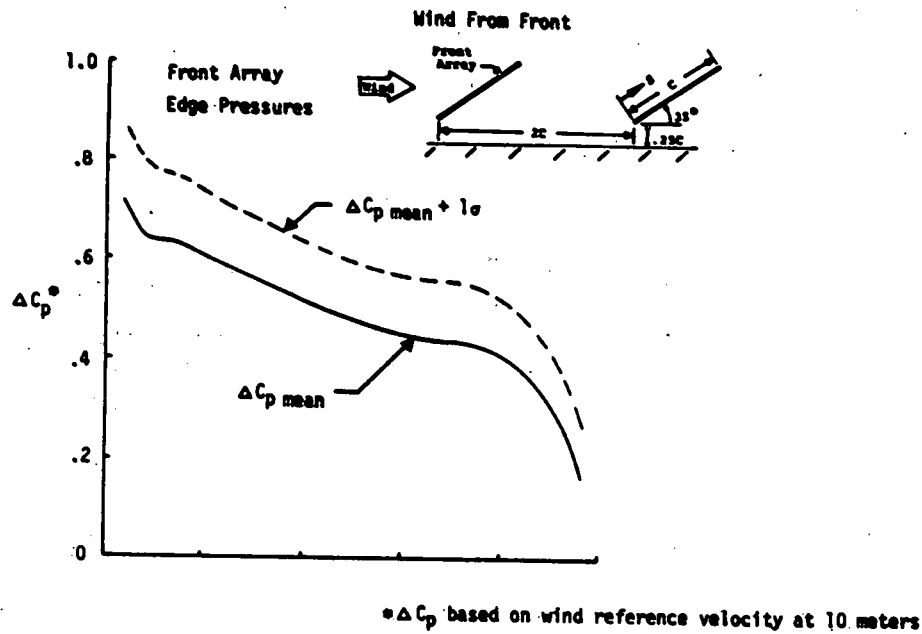
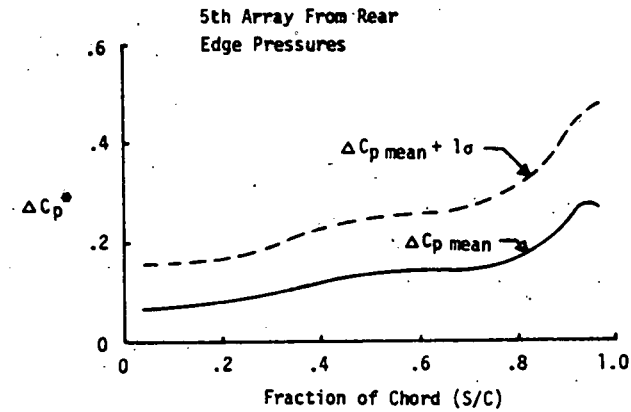
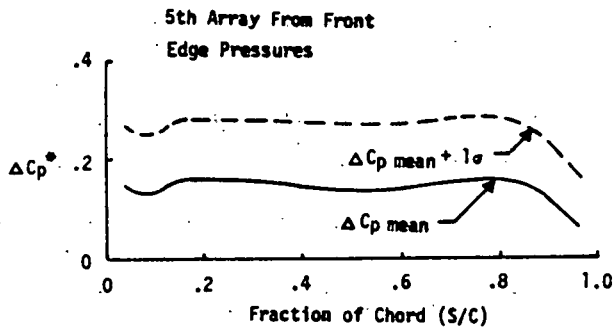
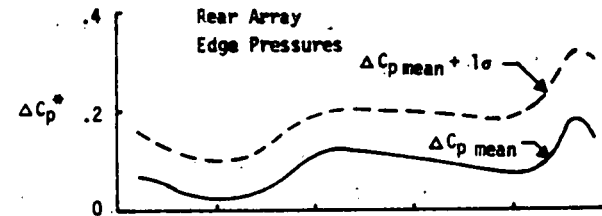
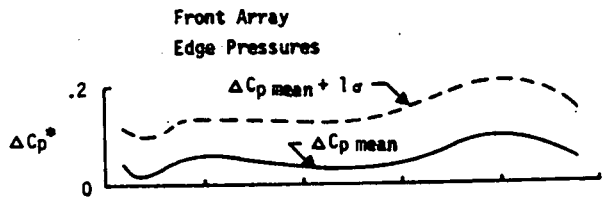
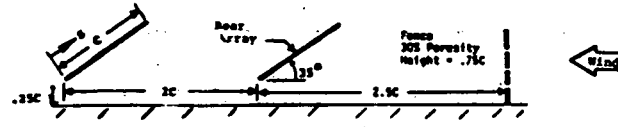
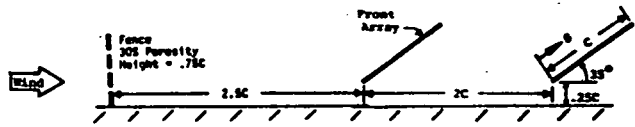

Figure 4-7. Array Chordwise Pressure Coefficient Distribution Located .15 Chord Lengths from Side Edge for Head-On and Rearward Winds (No Fence)

1/7 Power Law Wind Velocity Profile



* ΔC_p based on wind reference velocity at 10 meters

Figure 4-8. Effect of Fence on Array Chordwise Pressure Coefficient Distribution Located .15 Chord Lengths from Side Edge for Head-On and Rearward Winds

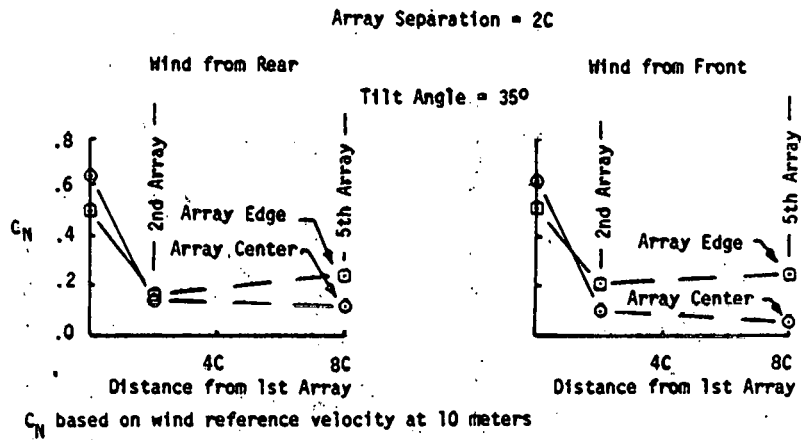

Figure 4-9. Comparison Between Array Edge and Center of Span Normal Force Coefficients for Head-On and Rearward Winds (No Fence)

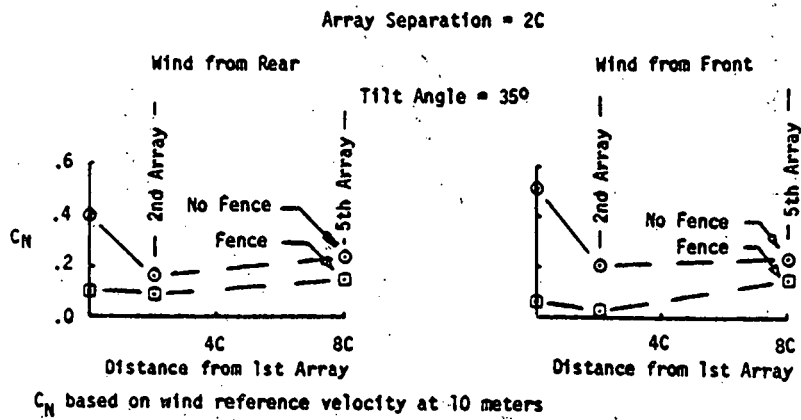
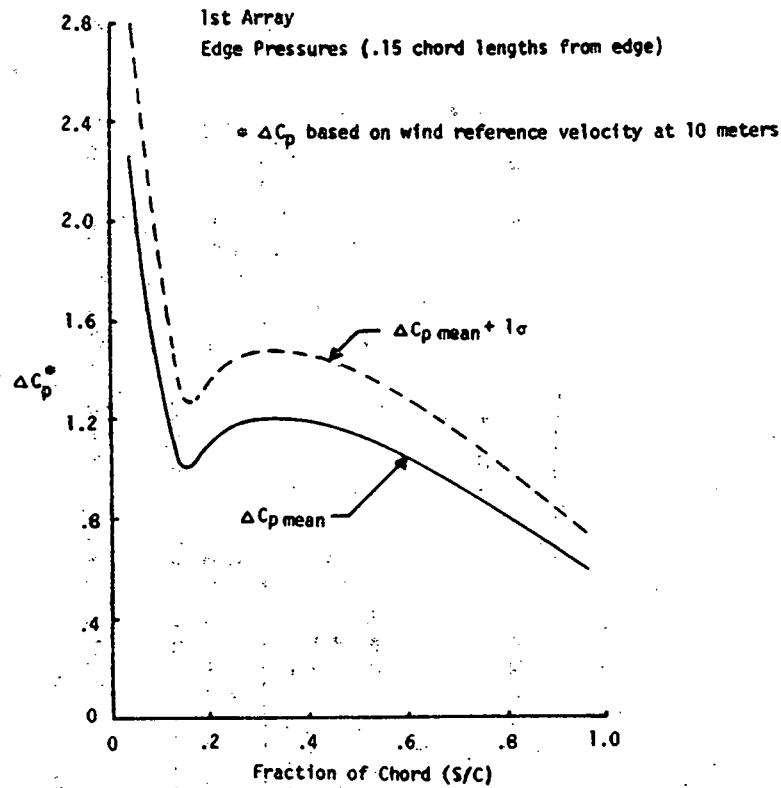
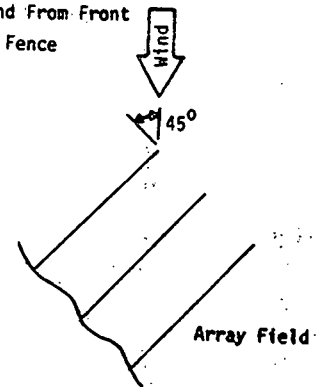

Figure 4-10. Effect of Fence on Array Edge Normal Force Coefficients for Head-On and Rearward Winds



1/7 Power Law Wind Velocity Profile
Wind From Front
No Fence



Array Conditions:
Tilt Angle = 35°
Separation = $2C$
Height above ground = $.25C$

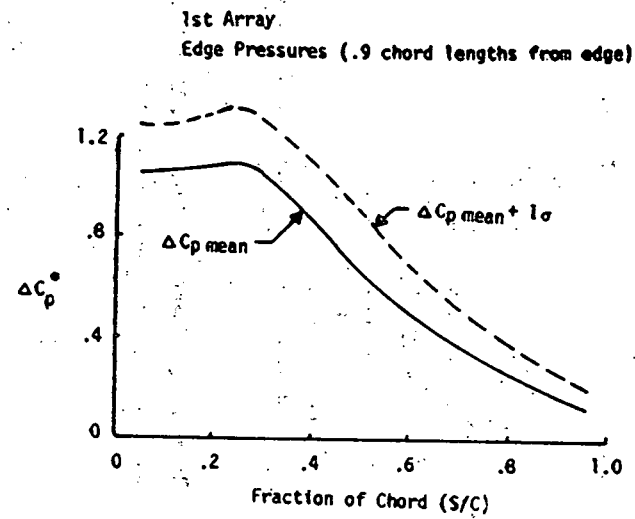

ΔC_p based on wind reference velocity at 10 meters

Figure 4-11a Effect of Oblique Winds on Array Edge Pressure Distribution
(No Fence, Wind from Front)

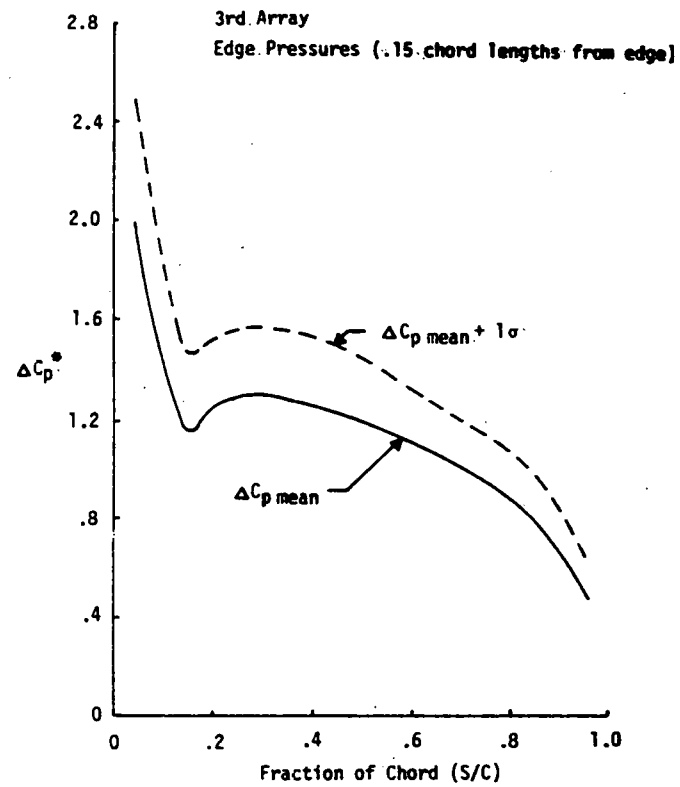
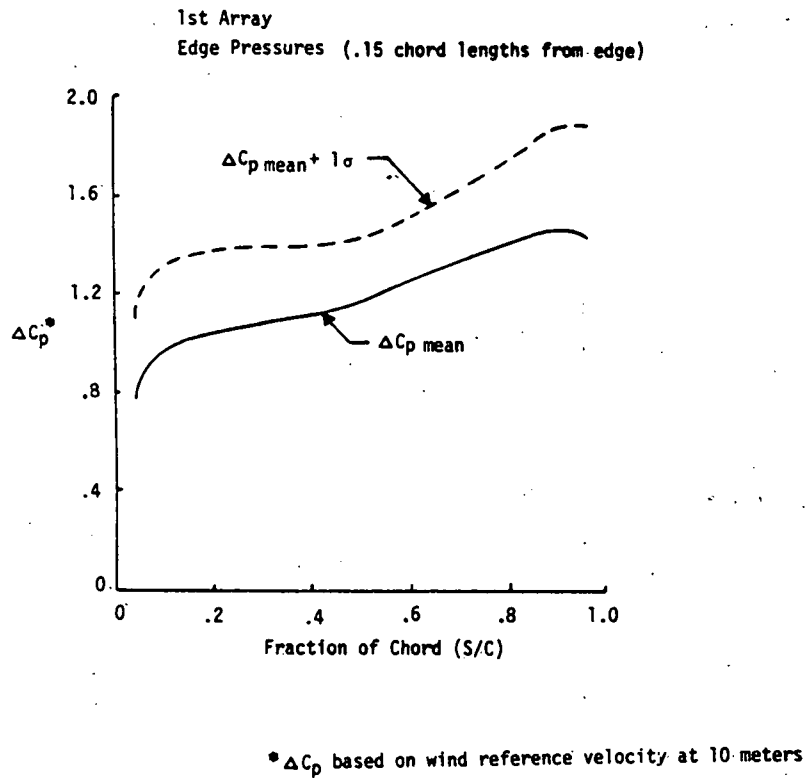

Figure 4-11a. Concluded



1/7 Power Law Wind Velocity Profile

Wind from Rear
No Fence



45°

Array Conditions:

Tilt Angle = 35°

Separation = 2C

Height above ground = .25C

Array Field

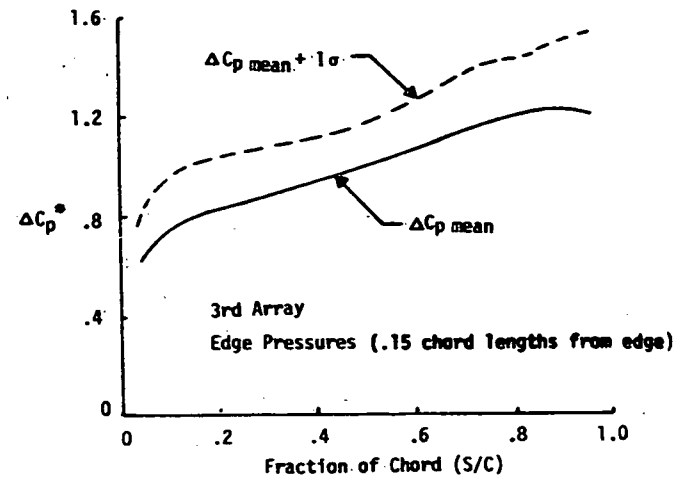

Figure 4-11b. Effect of Oblique Winds on Array Edge Pressure Distribution
(No Fence, Wind from Rear)

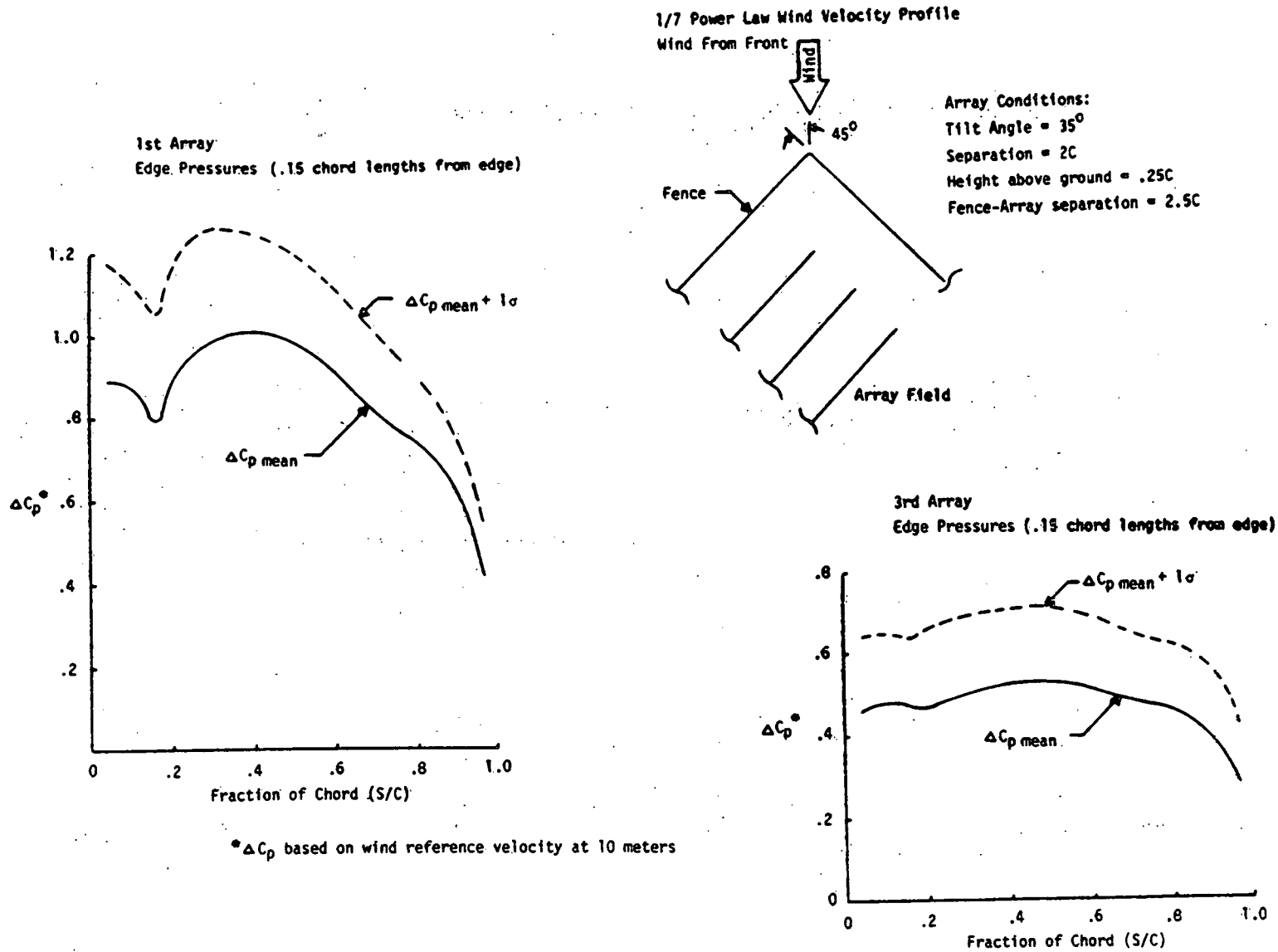
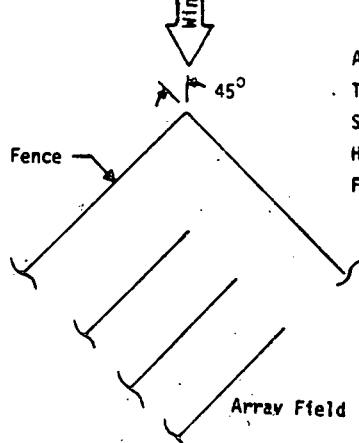

Figure 4-11c. Effect of Oblique Winds on Array Edge Pressure Distribution (Conventional Fence, Wind from Front)

1/7 Power Law Wind Velocity Profile

Wind From Rear



Array Conditions:
 Tilt Angle = 35°
 Separation = 2C
 Height above ground = .25C
 Fence-Array separation = 2.5C

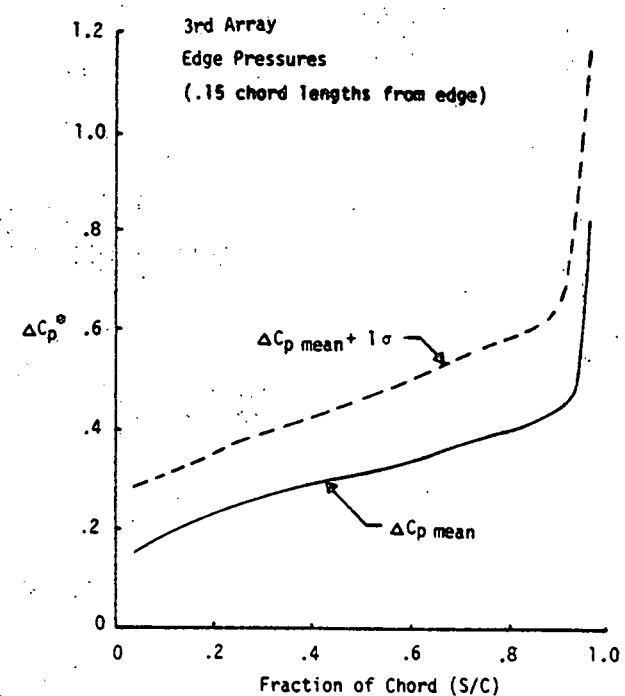
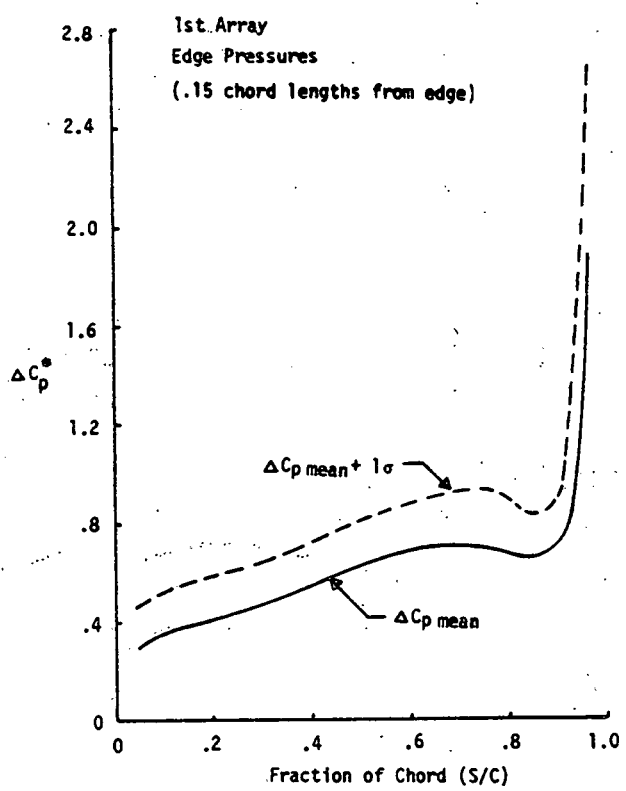

Figure 4-11d. Effect of Oblique Winds on Array Edge Pressure Distribution (Conventional Fence, Wind from Rear)

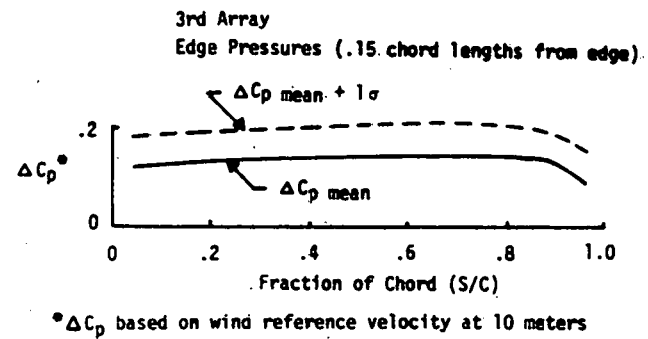
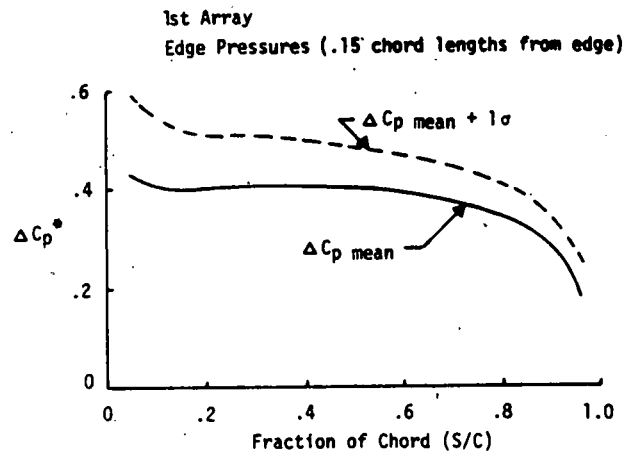
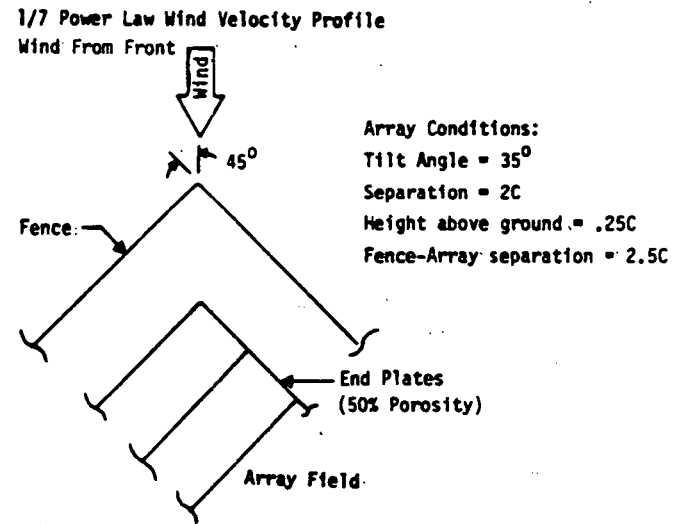
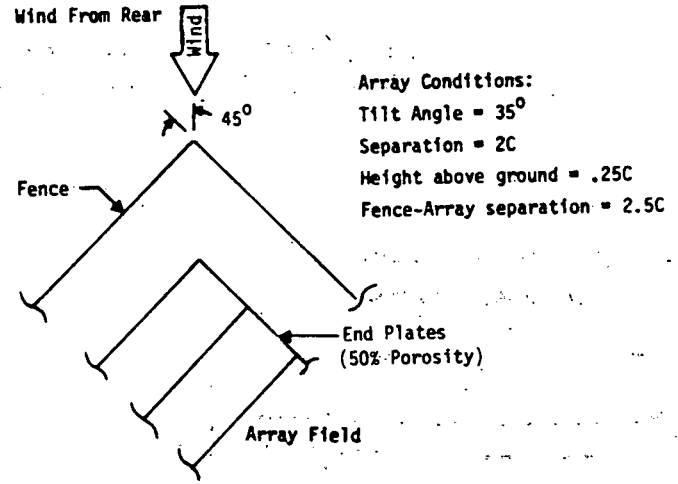

Figure 4-11e. Effect of Oblique Winds on Array Edge Pressure Distribution
(Conventional Fence, Endplated Arrays, Wind from Front)

1/7 Power Law Wind Velocity Profile



57

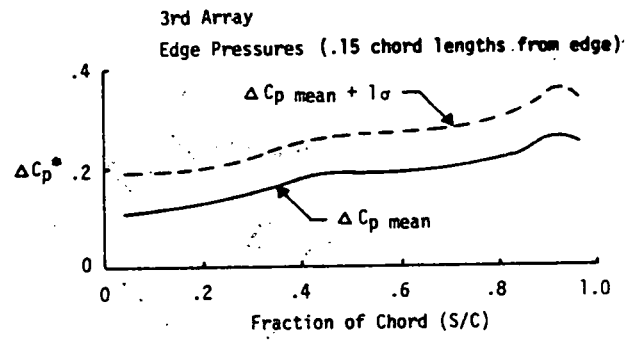
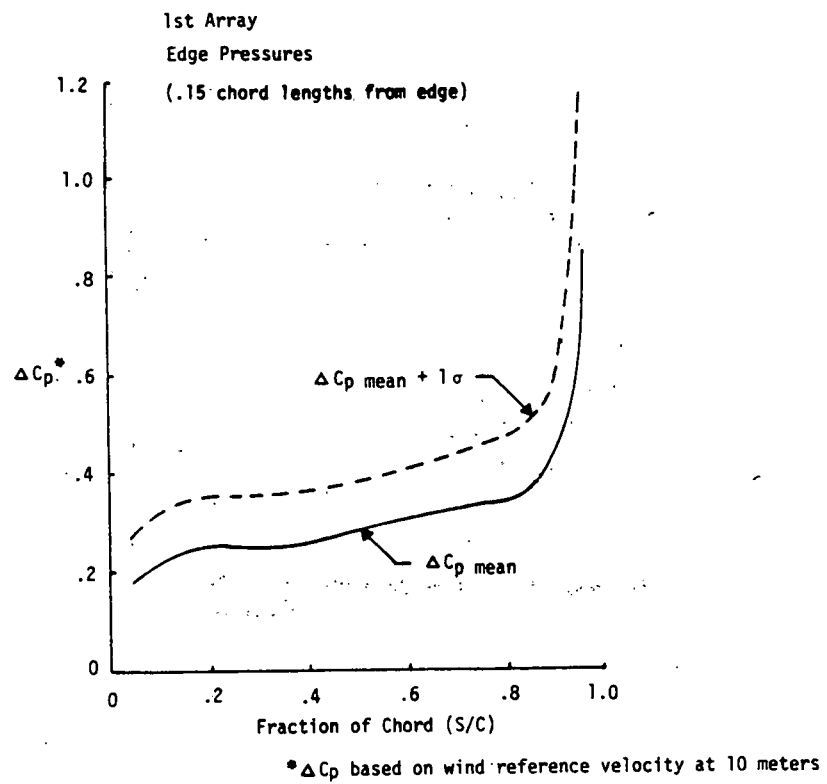
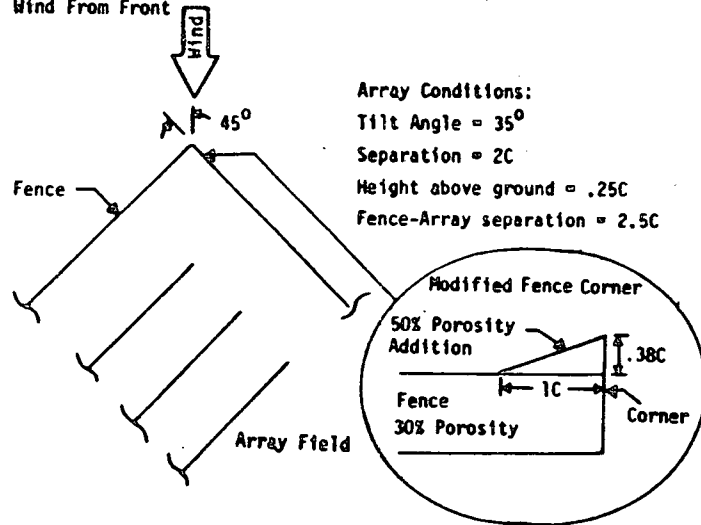
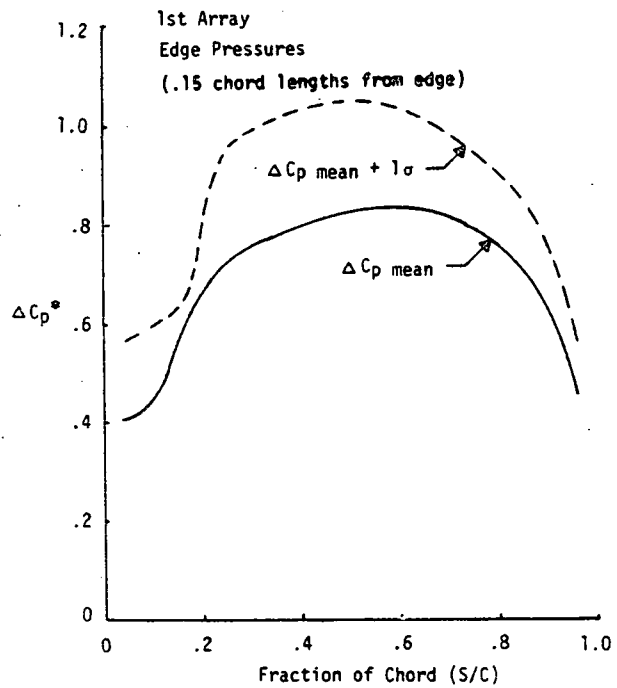

Figure 4-11f. Effect of Oblique Winds on Array Edge Pressure Distribution (Conventional Fence, Endplated Arrays, Wind from Rear)

1/7 Power Law Wind Velocity Profile
Wind From Front



58



* ΔC_p based on wind reference velocity at 10 meters

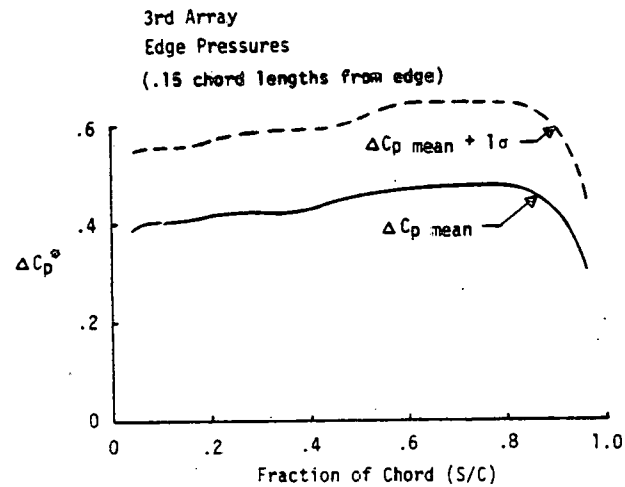

Figure 4-11g. Effect of Oblique Winds on Array Edge Pressure Distribution
(Modified Fence Corner, Wind from Front)

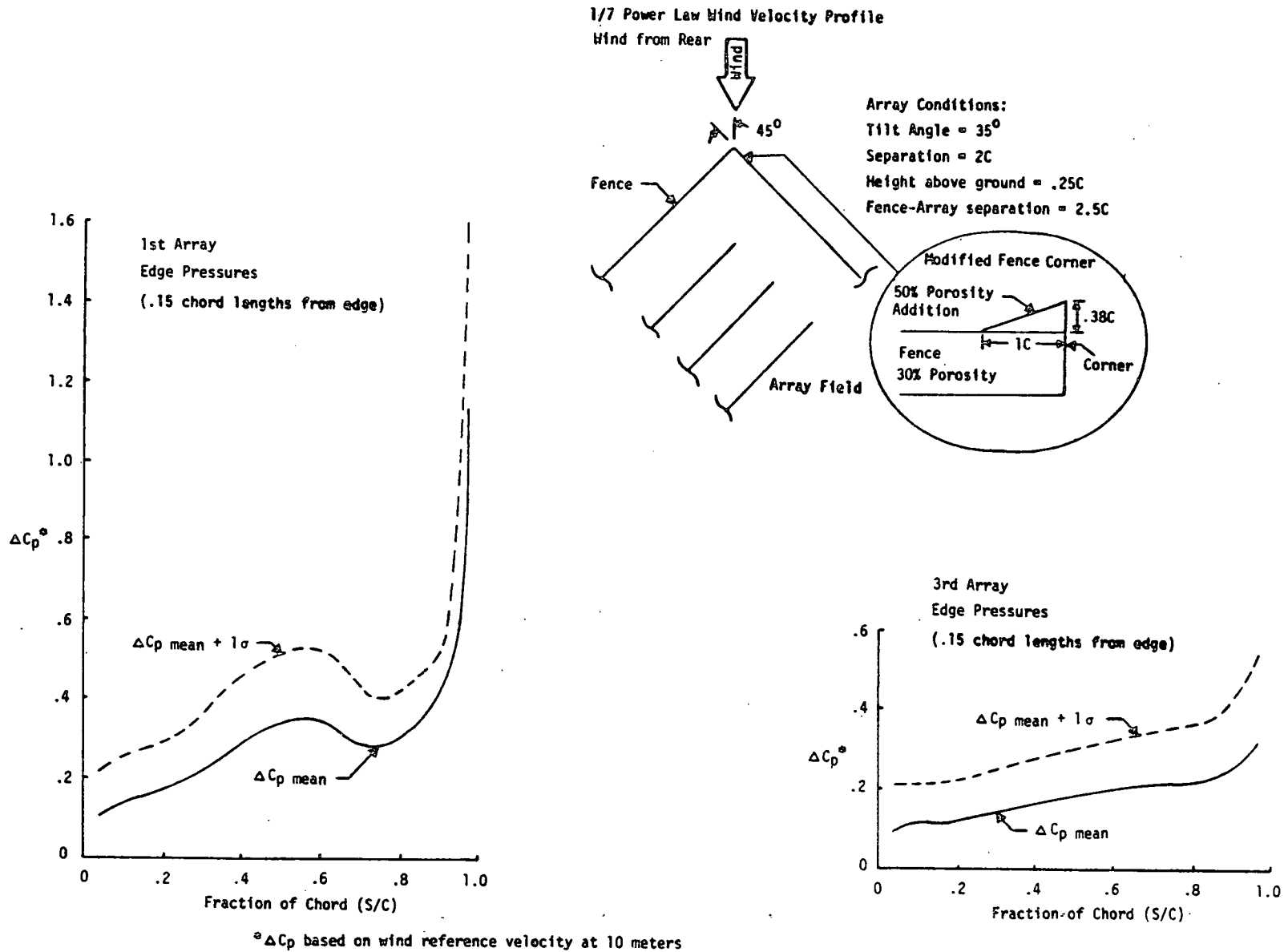

Figure 4-11h. Effect of Oblique Winds on Array Edge Pressure Distribution (Modified Fence Corner, Wind from Rear)

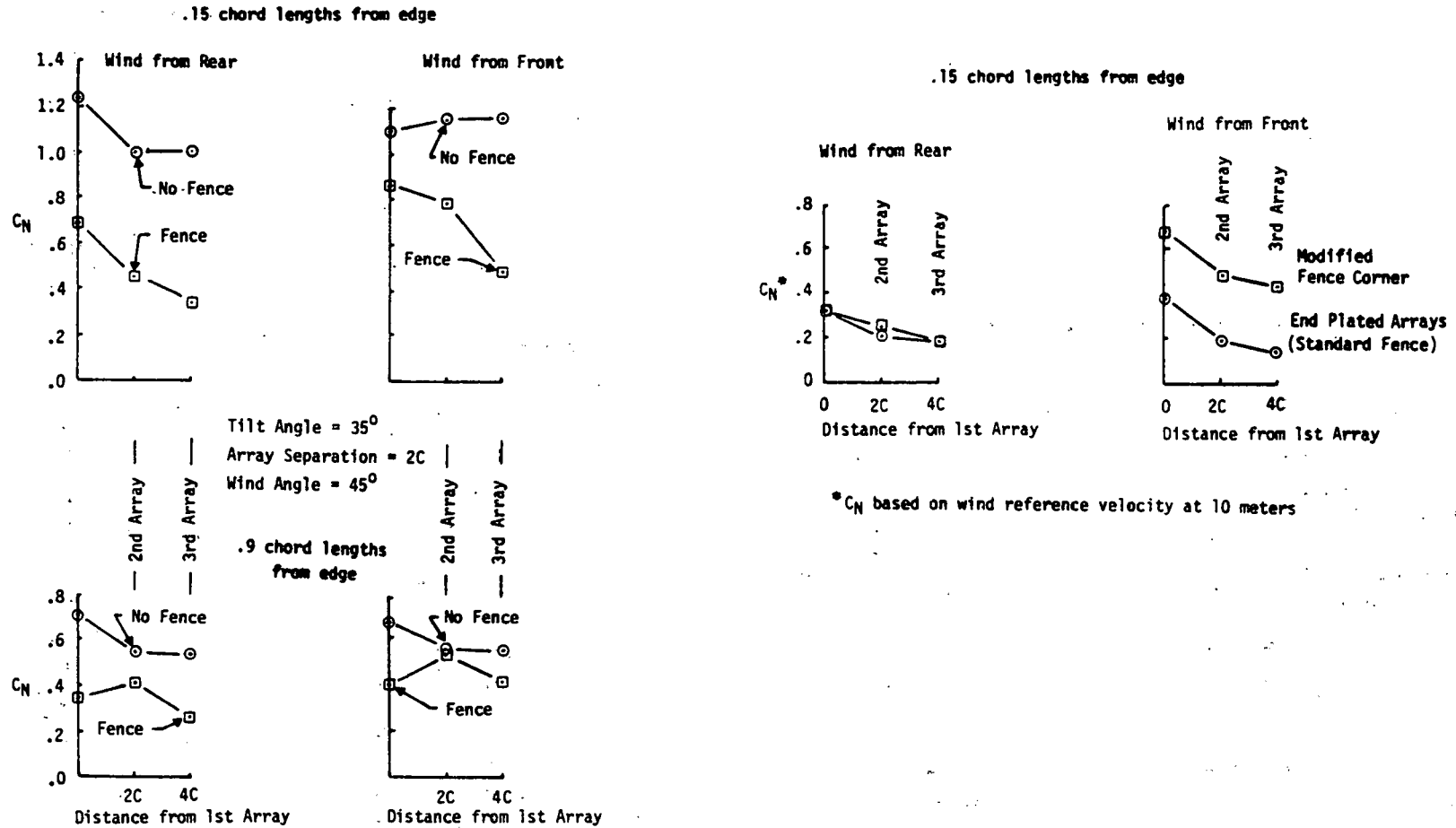

Figure 4-12. Effect of Oblique Winds on Array Normal Force Coefficients at Array Edge

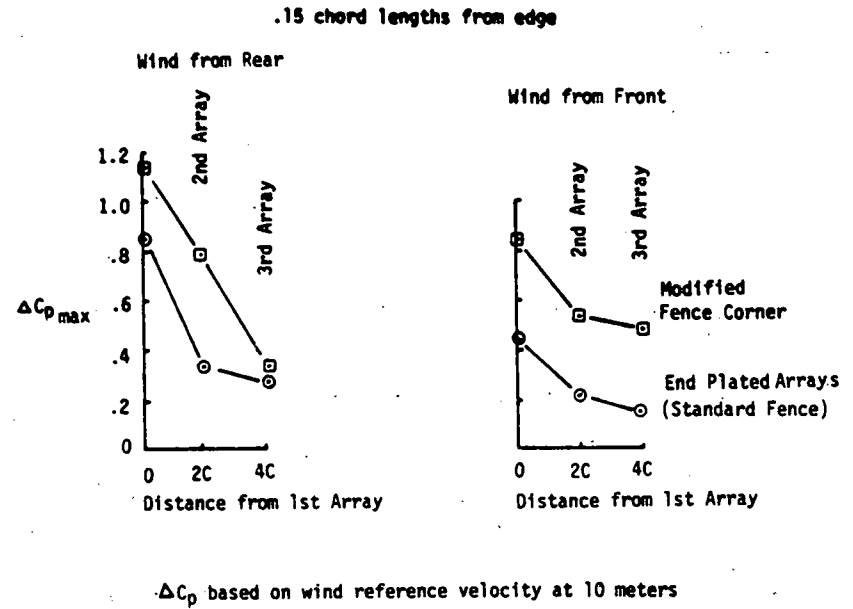
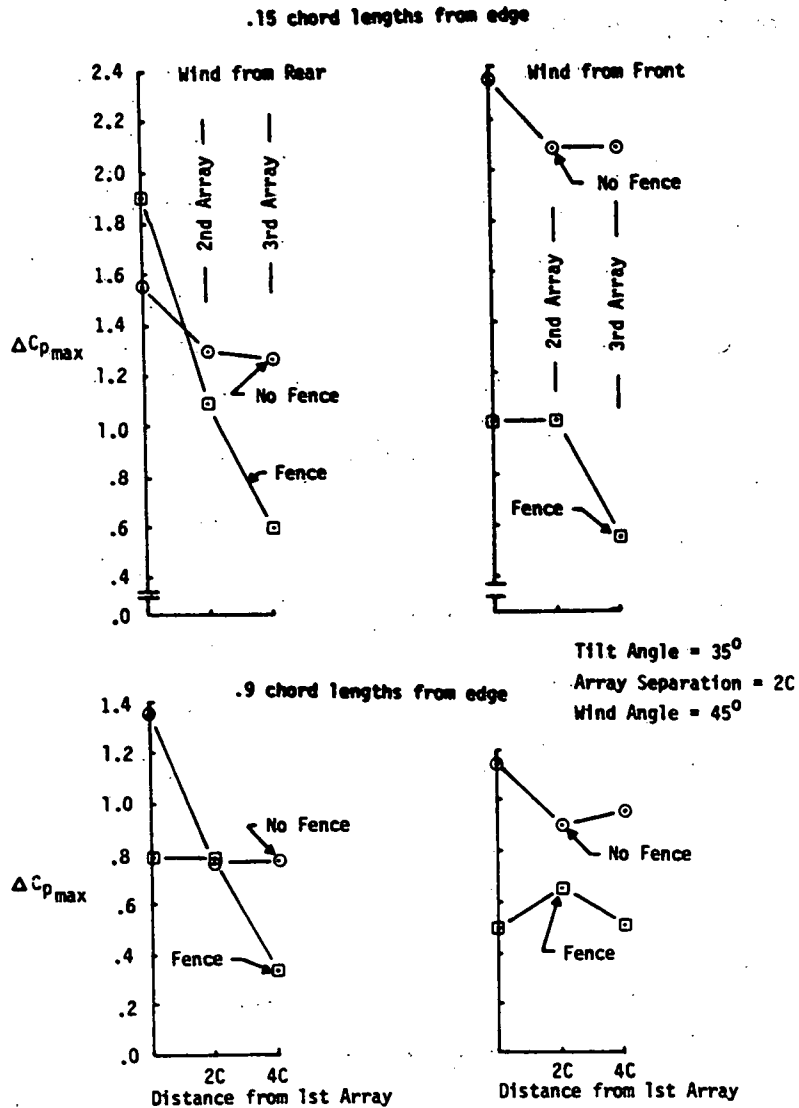

Figure 4-13. Maximum Pressure Coefficient at Array Side Edge Due to Oblique Winds

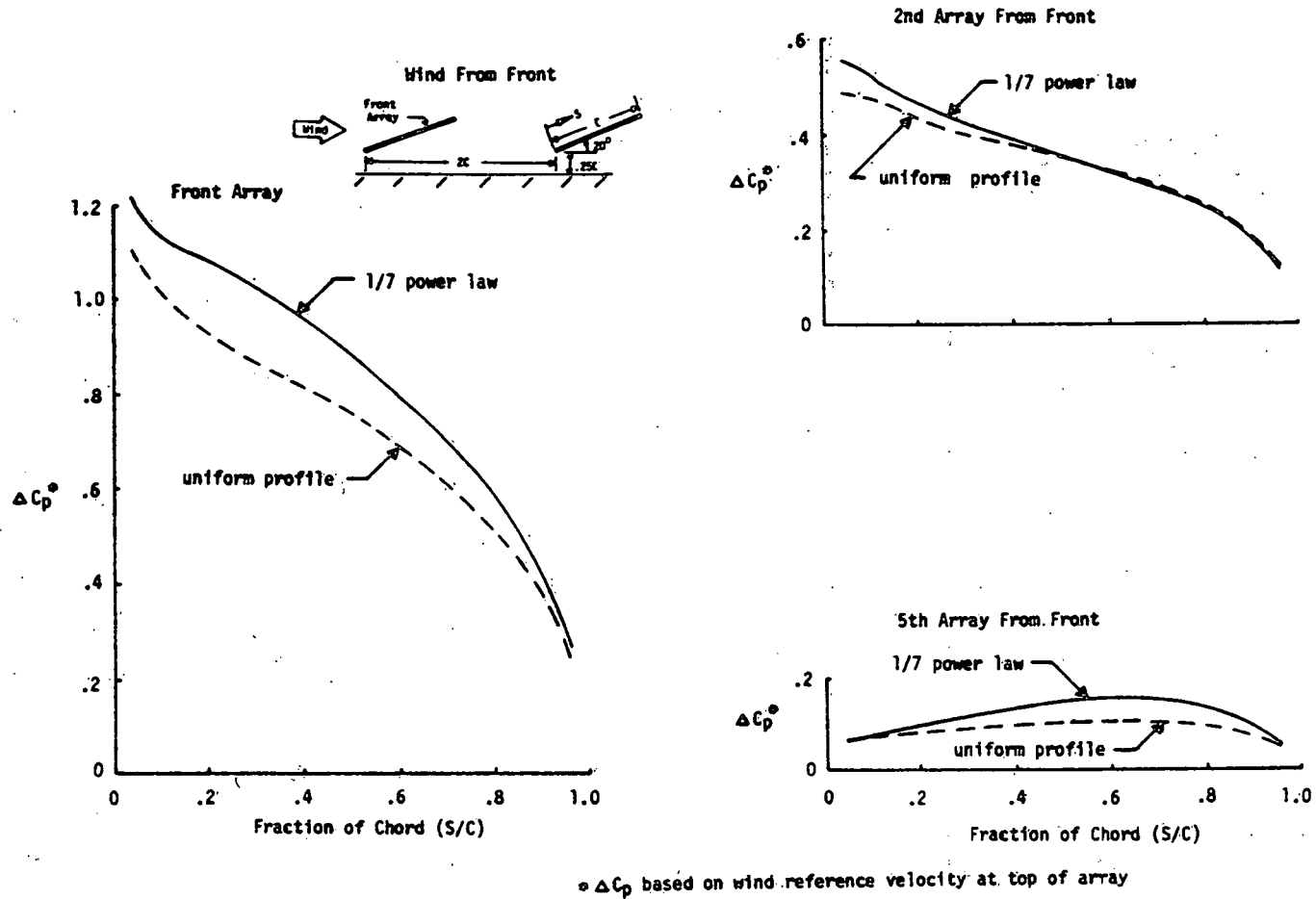

Figure 4-14a. Array Pressure Coefficient Comparison Between Uniform and Boundary Layer Wind Profiles (Tilt Angle = 20°, Wind from Front)

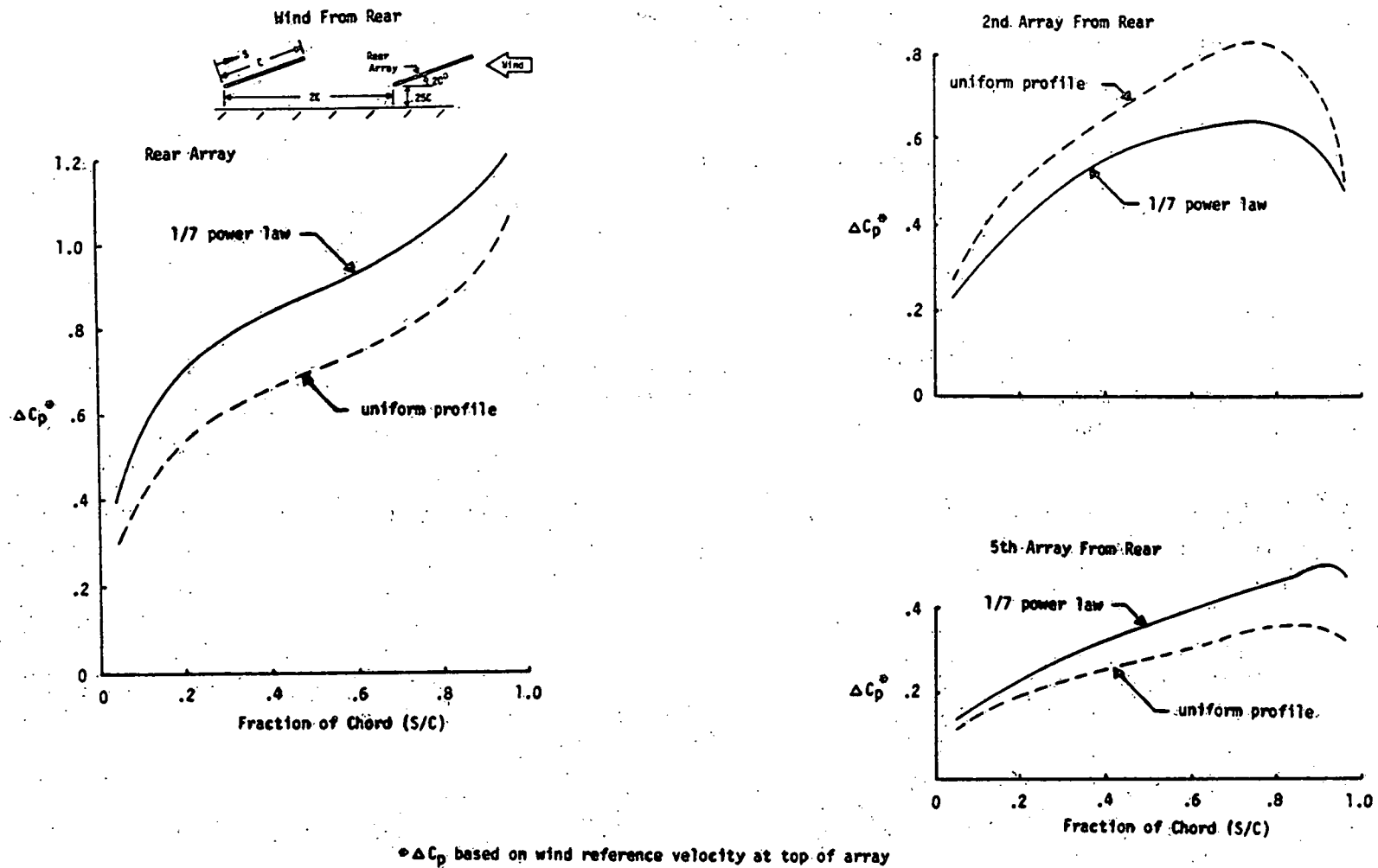
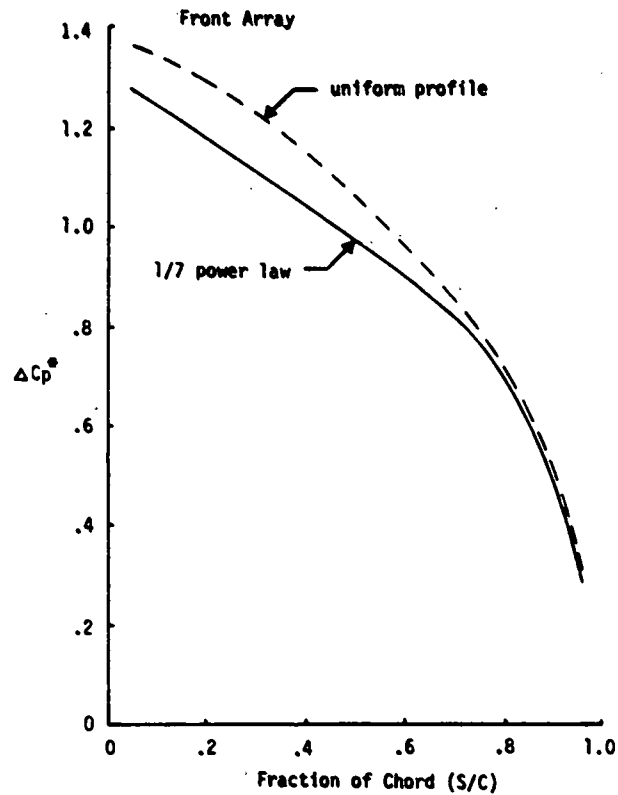

Figure 4-14b. Array Pressure Coefficient Comparison Between Uniform and Boundary Layer Wind Profiles (Tilt Angle = 20° , Wind from Rear)



* ΔC_p based on wind reference velocity at top of array

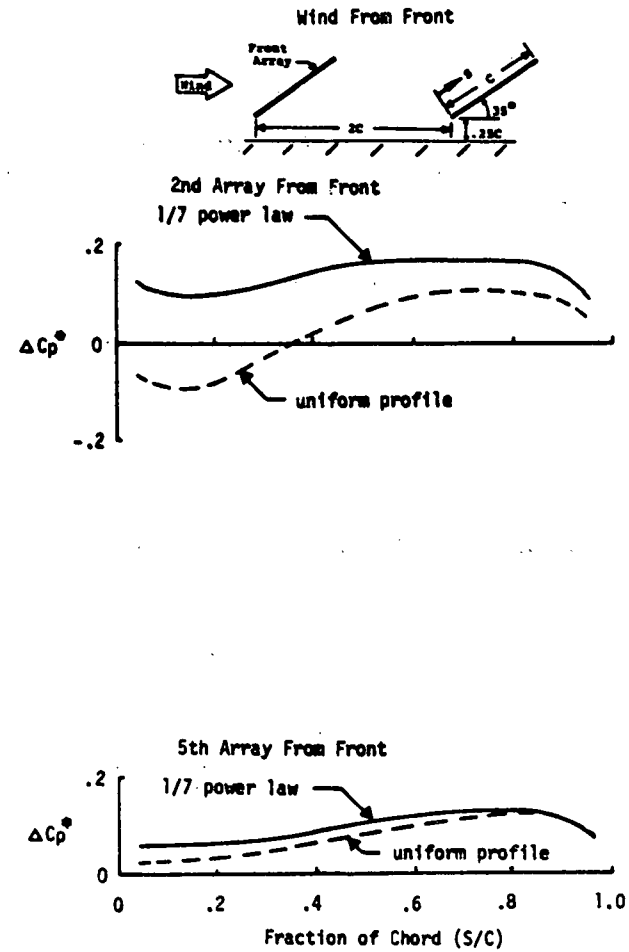

Figure 4-14c. Array Pressure Coefficient Comparison Between Uniform and Boundary Layer Wind Profiles (Tilt Angle = 35° , Wind from Front)

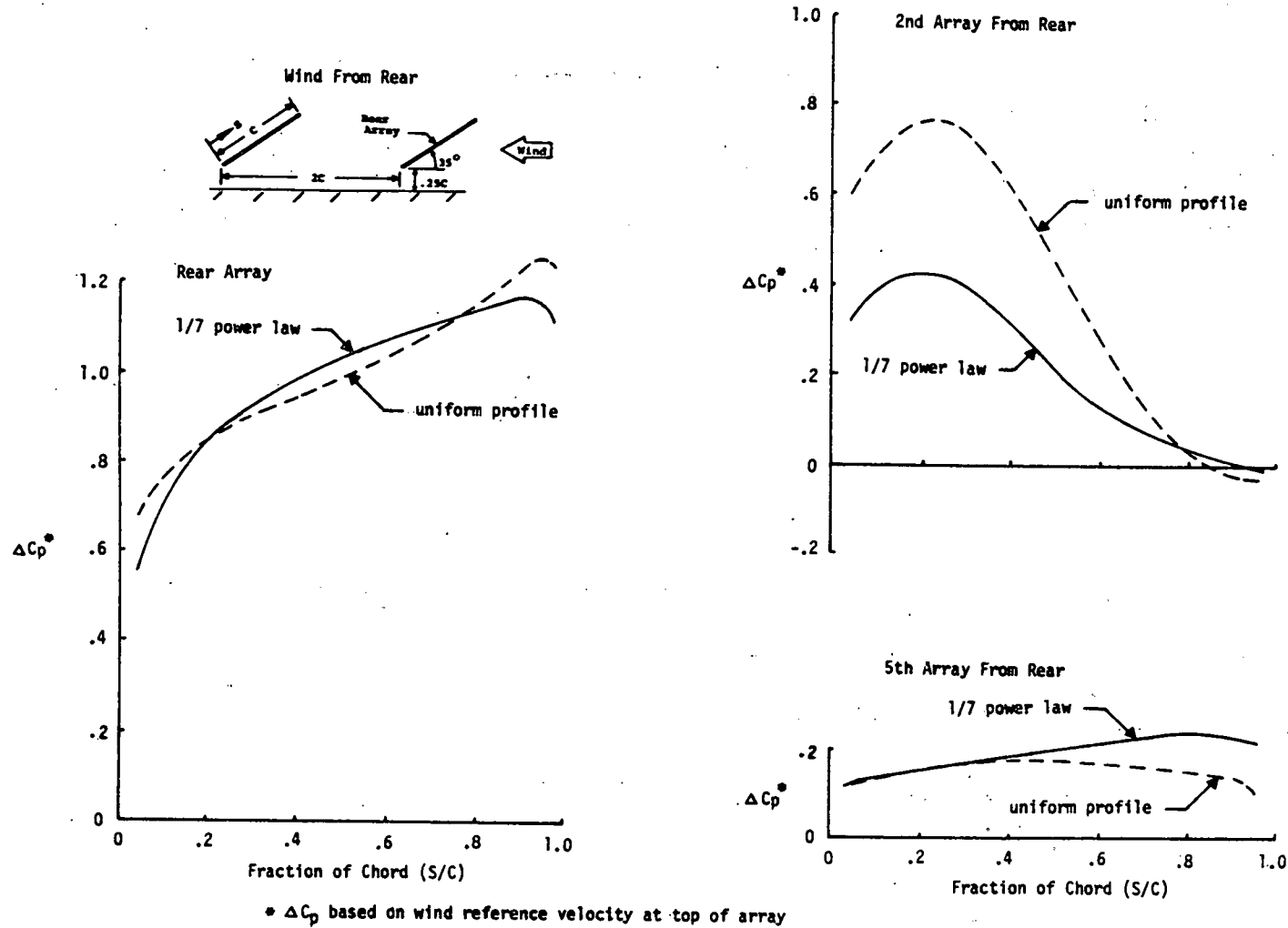

Figure 4-14d. Array Pressure Coefficient Comparison Between Uniform and Boundary Layer Wind Profiles (Tilt Angle= 35° , Wind from Rear)

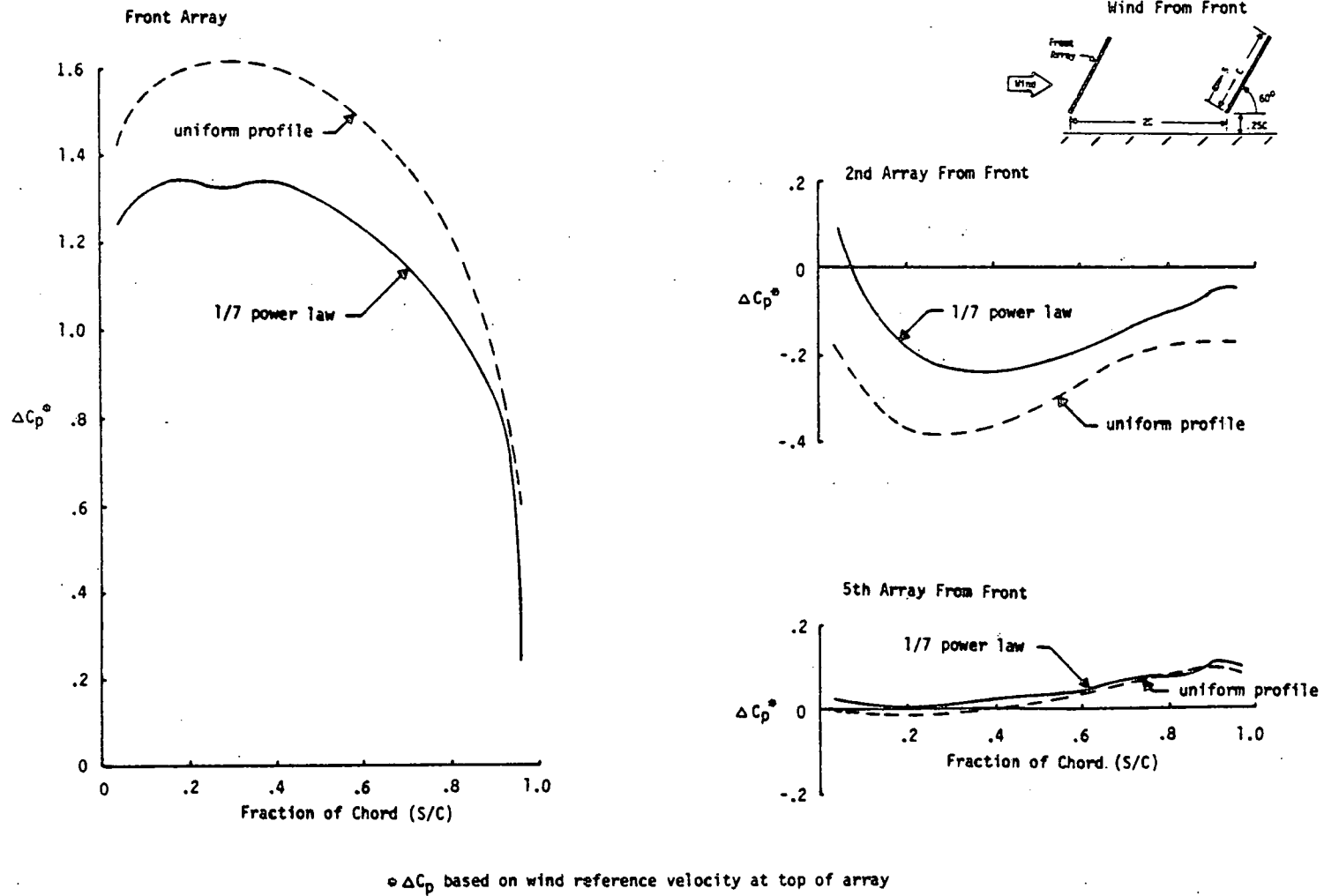

Figure 4-14e. Array Pressure Coefficient Comparison Between Uniform and Boundary Layer Wind Profiles (Tilt Angle = 60°, Wind from Front)

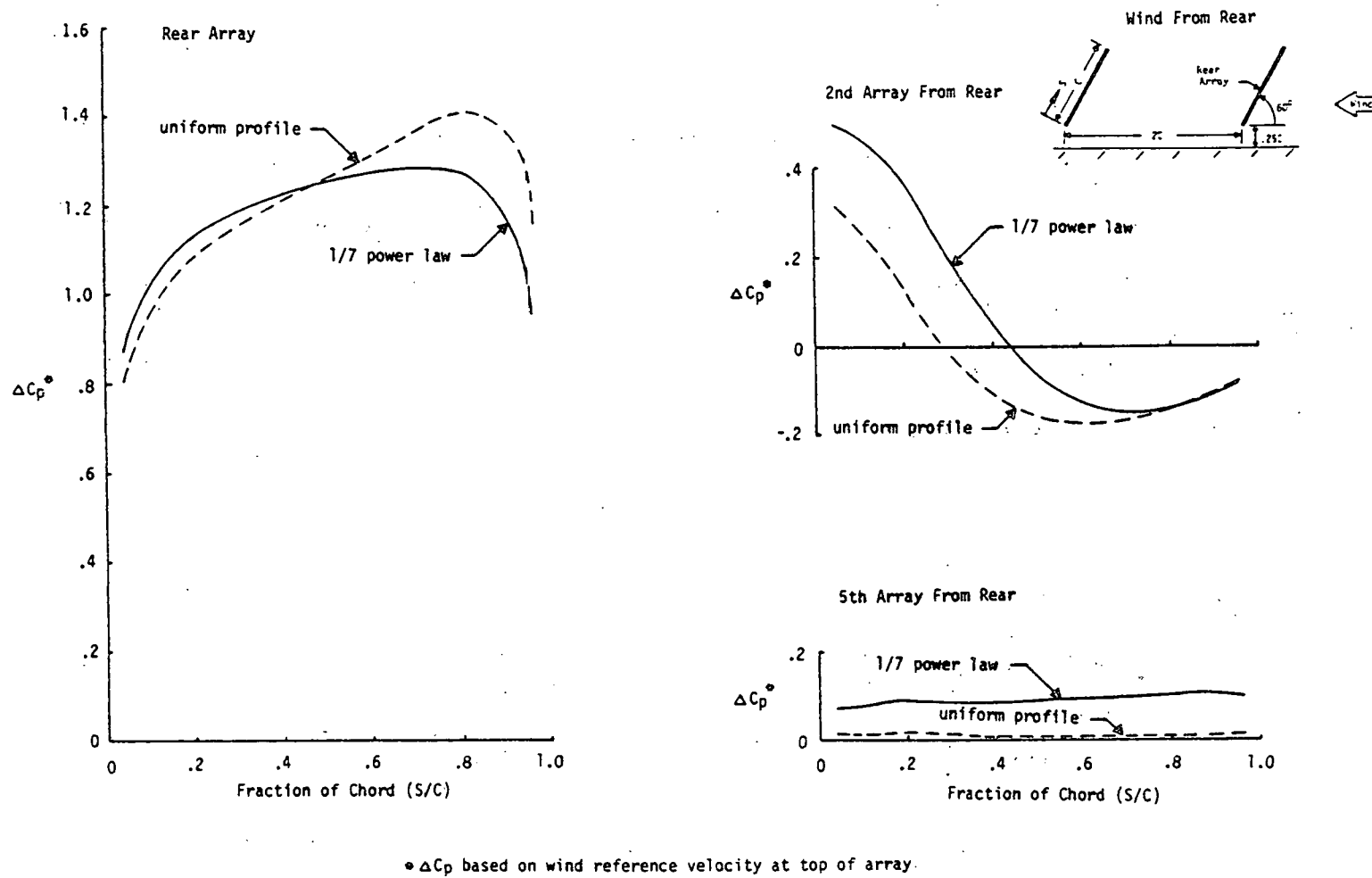
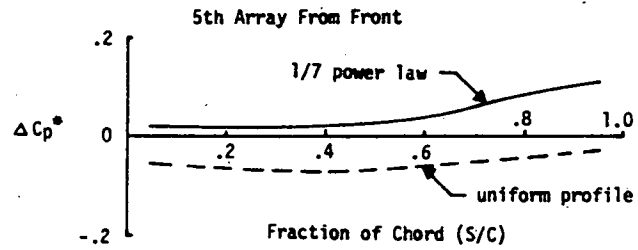
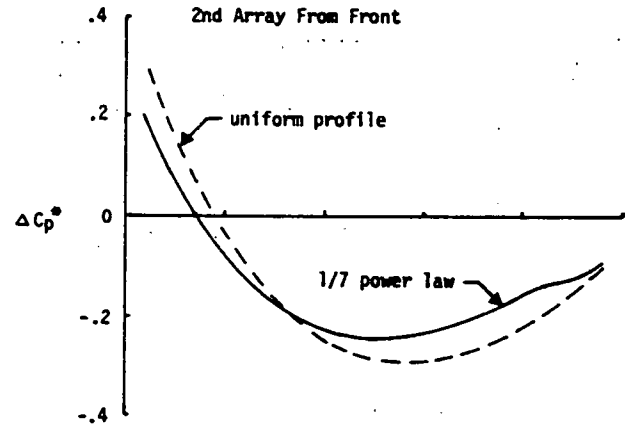
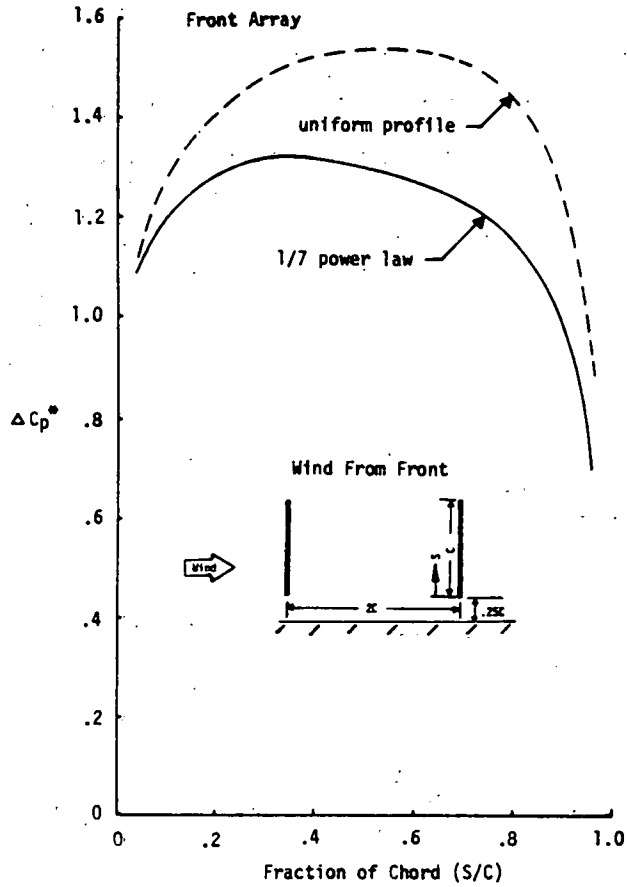

Figure 4-14f. Array Pressure Coefficient Comparison Between Uniform and Boundary Layer Wind Profiles (Tilt Angle = 60°, Wind from Rear)



* ΔC_p based on wind reference velocity at top of array

Figure 4-14g. Array Pressure Coefficient Comparison Between Uniform and Boundary Layer Wind Profiles (Tilt Angle = 90°)

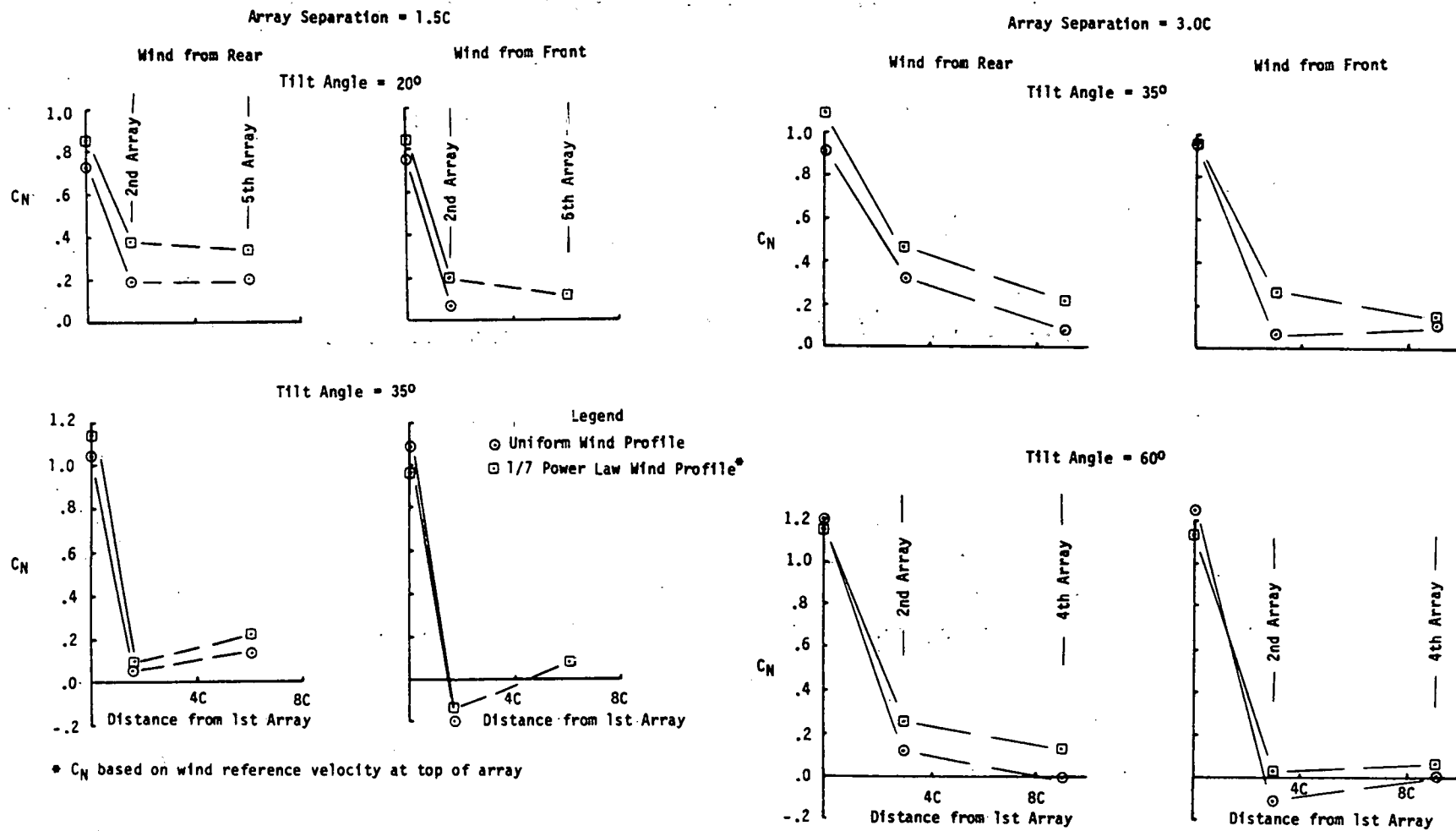

Figure 4-15. Array Normal Force Coefficient Comparison Between Uniform and Boundary Layer Wind Profiles.

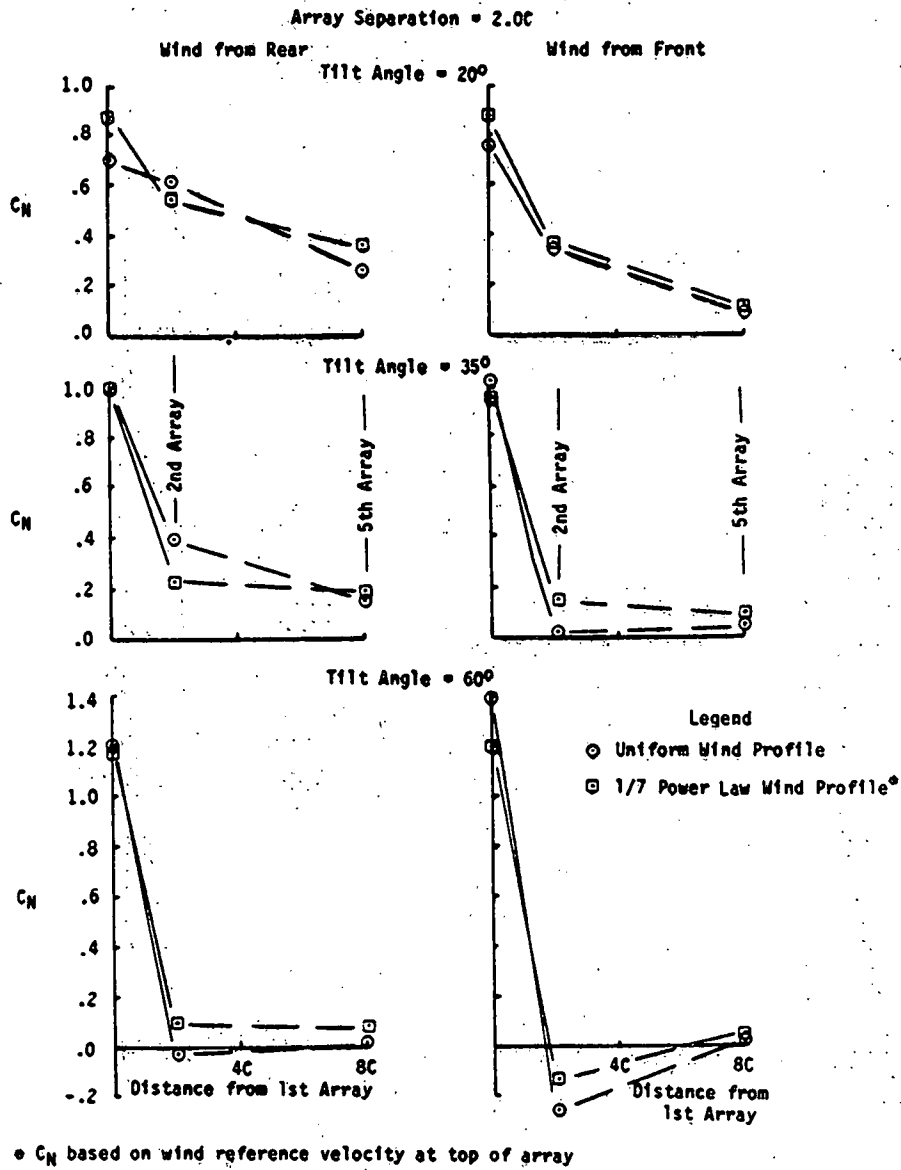

Figure 4-15. Concluded

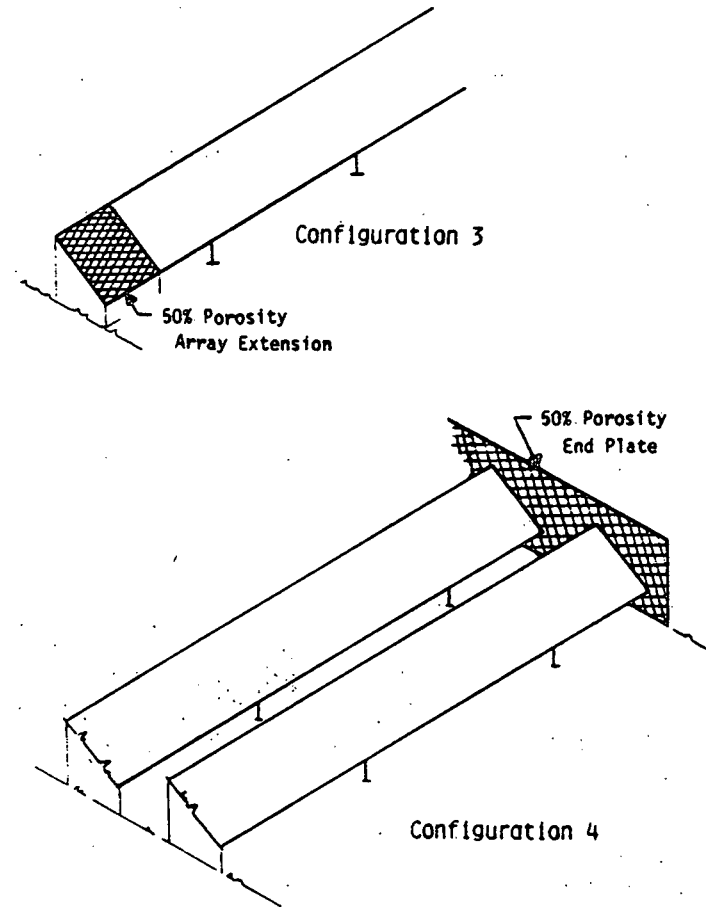
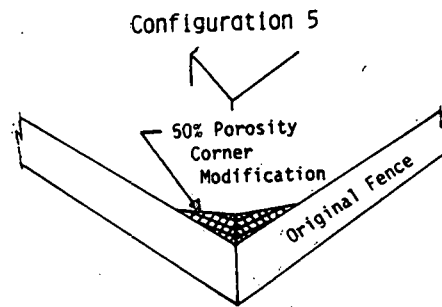
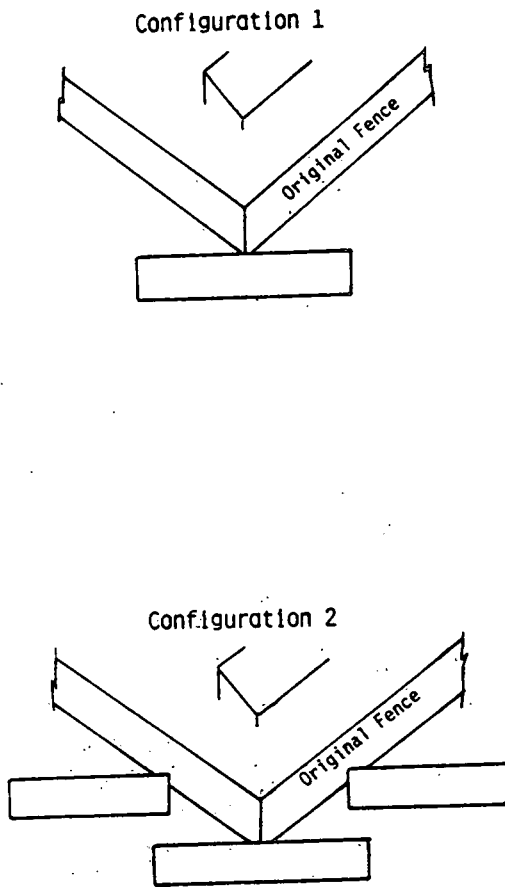

Figure 4-16. Configurations for Edge Load Reduction Study

THIS PAGE
WAS INTENTIONALLY
LEFT BLANK

5.0 THEORETICAL - EXPERIMENTAL RESULTS COMPARISON

The theoretical results developed in Phase II and presented in reference 5 were calculated based on a uniform velocity profile and were then adjusted to reflect the boundary layer velocity profile. Figure 5-1 shows the comparison of the theoretical results to the wind tunnel test results for the net pressure coefficient distribution along the chord of a single array located out of the influence of the ground and in a uniform velocity profile for three angles of attack (20° , 35° , and 60°). (Since the theoretical results were based on an infinite aspect ratio array, all theoretical-experimental comparisons utilize the mid-span test results.) The results differ by approximately 5% to 10% except for very low pressure coefficients; this comparison is considered very good and demonstrates that theoretical methods can be used to accurately predict the aerodynamic loads on an array located sufficiently far from the ground so that ground effects are not a consideration.

When the array is located in close ground proximity, the theoretical method tends to overpredict the pressure coefficients as compared to the wind tunnel test; this is shown in Figure 5-2. When the tilt angle of the array is small (20°), the theoretical results match the wind tunnel test results within approximately 20% or less. However, as the tilt angle increases (35° and 60°), the theoretical-experimental results become increasingly farther apart. The difference is due (at least in part) to the blockage effect that occurs to the air flow because of the restricted area between the ground and the lower edge of the array and the effects of air viscosity (not considered in the theoretical model) in this restricted flow regime. From the test results, of which Figure 5-3 is a typical example, flow blockage is seen to occur because of the ground-to-array gap. Figure 5-3 indicates that the flow is blocked and decreases in velocity as the gap is reduced in value from $H/C = \infty$ to .25 as evidenced by the increase in pressure on the lower edge ($S/C = 0$) on the windward face of the array and by the smaller negative pressure on the base pressure face. Because of the flow restriction at the gap, the flow in front of the windward face of the array is also affected, and the windward face pressure distribution is modified across the total face depending on the amount of restriction of the flow. In contrast to the test results, the theoretical separated inviscid flow method predicts that the air flow increases in velocity to allow a given mass of air to flow through the gap to compensate for the restricted gap area. This increase in velocity is further intensified as the

array presents a more bluff configuration to the wind at increasing tilt angles. Consequently, because of the inviscid flow assumptions in the theoretical method, there is an increasing spread with tilt angle between theoretical and test results as the tilt angle is increased from 20°.

In the Phase II study, reference 5, it was recommended that the theoretical normal force and pressure coefficients for all downwind arrays be calculated as 60% of the windward array. The amount of protection afforded to the downwind arrays in an array field is more complex than can be covered by a blanket percent reduction as shown in Figure 5-4; it is a function of the tilt angle and to a lesser extent, the wind direction. In general, the larger the tilt angle, the greater is the protection afforded to the downwind arrays by the windward array and the greater the load reduction. From the theoretical - experimental data comparison, the theoretical results presented in reference 5 are conservative for steady state wind loads on arrays without protective fences and can be used for design studies of photovoltaic flat plate arrays in lieu of specific test data relating to the design. However, the design would be penalized in terms of structural costs by the conservative loads.

When a fence is used as a protective wind barrier for the arrays, reference 5 recommended using the velocity isotachs behind a fence to calculate the dynamic pressure. Using this dynamic pressure with the theoretical normal force coefficients, the average normal forces per unit area were calculated and presented in reference 5 as Table 6-2 for various tilt angles and for an 8.2 foot fence. The appropriate results were extracted and are presented in Table 5-1 of this document, together with the results from the wind tunnel test for arrays positioned behind a 6 foot fence and in a boundary layer wind. The comparison is reasonably satisfactory at the 20° tilt angle, less so at 35°, and poor at 60°. Thus, the technique suggested in reference 5 should only be used for the smaller tilt angles and only when more reliable results are not available.

Table 5-1. Example of Average Normal Wind Forces on Arrays behind Protective Fences by Theoretical and Wind Tunnel Test Methods (Behind)

Wind from Front			
Tilt Angle	Average Normal Wind Forces per unit area (psf)		
	20°	35°	60°
Theory *	1.06	1.63	9.62
W.T. Test	1.03	2.46	4.92
Wind from Rear			
Theory *	1.63	2.22	11.21
W.T. Test	1.44	2.46	5.13

* Dynamic factor of 1.5 removed from Table 6-2, reference 5

The array key wind parameters detailed in reference 5 are also shown in Figure 5-5. These parameters were verified by the wind tunnel test except for the dynamic pressure which is a fundamental parameter used in both test and theoretical methods. In general, the trends of all parameters, except ground clearance, were verified. However, the test results show that the parameters are all interrelated and cannot be separated as in Figure 5-5. As an example, angle of attack, ground clearance, and array spacing, are all affected by each other. Consequently, to predict the sensitivity precisely, a family of curves would be required varying only one parameter at a time. This would require an enormous amount of test data and results.

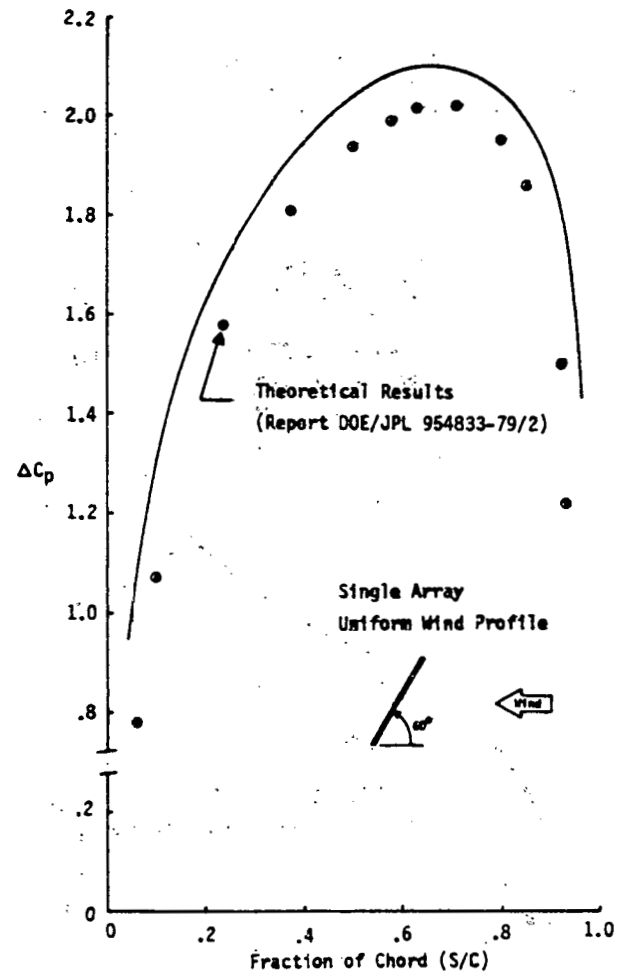
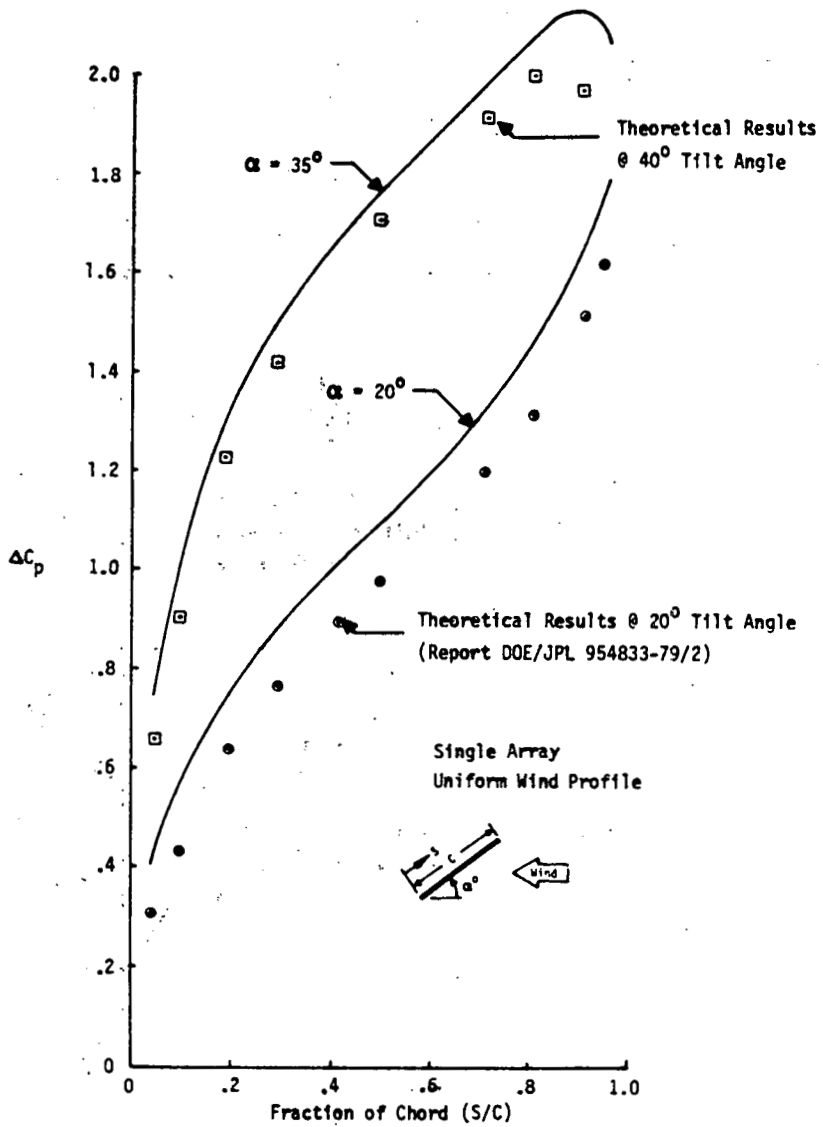

Figure 5-1. Array Pressure Coefficient Distribution Comparison Between Wind Tunnel Test and Theoretical Methods in Free Air

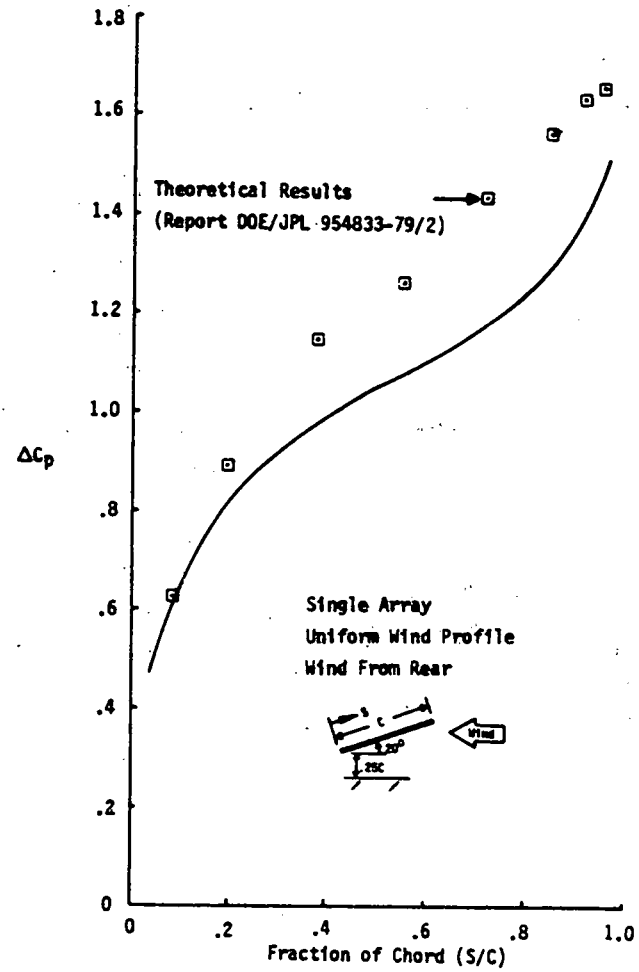
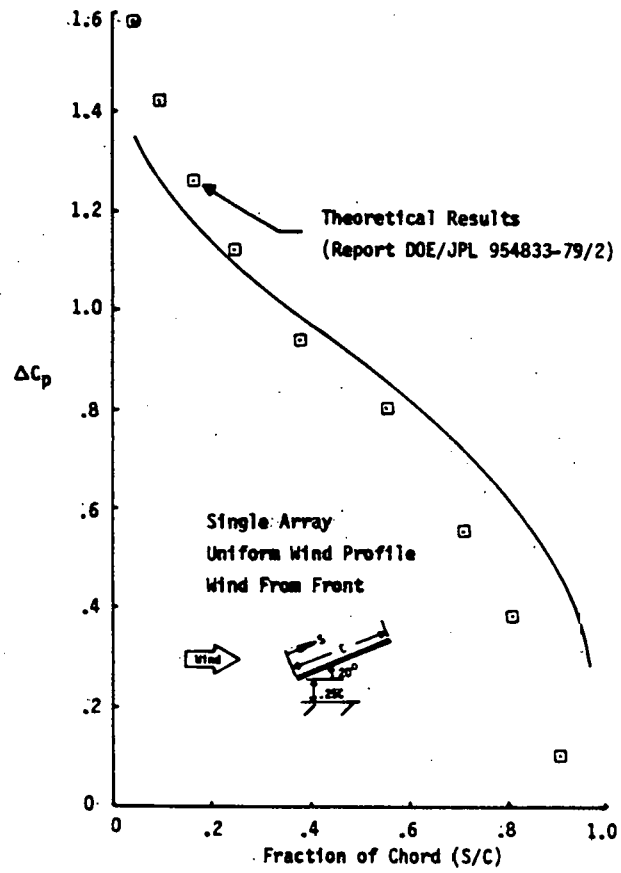

Figure 5-2a. Array Pressure Coefficient Distribution Comparison Between Wind Tunnel Test and Theoretical Methods in Close Ground Proximity (Tilt Angle = 20°)

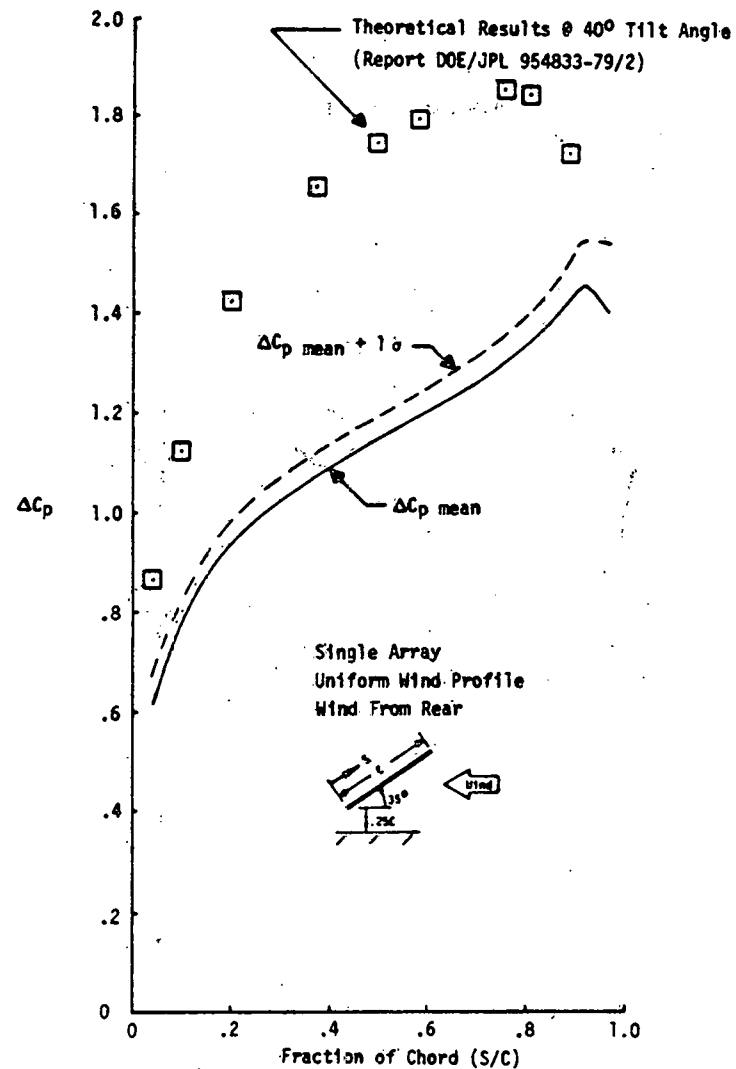
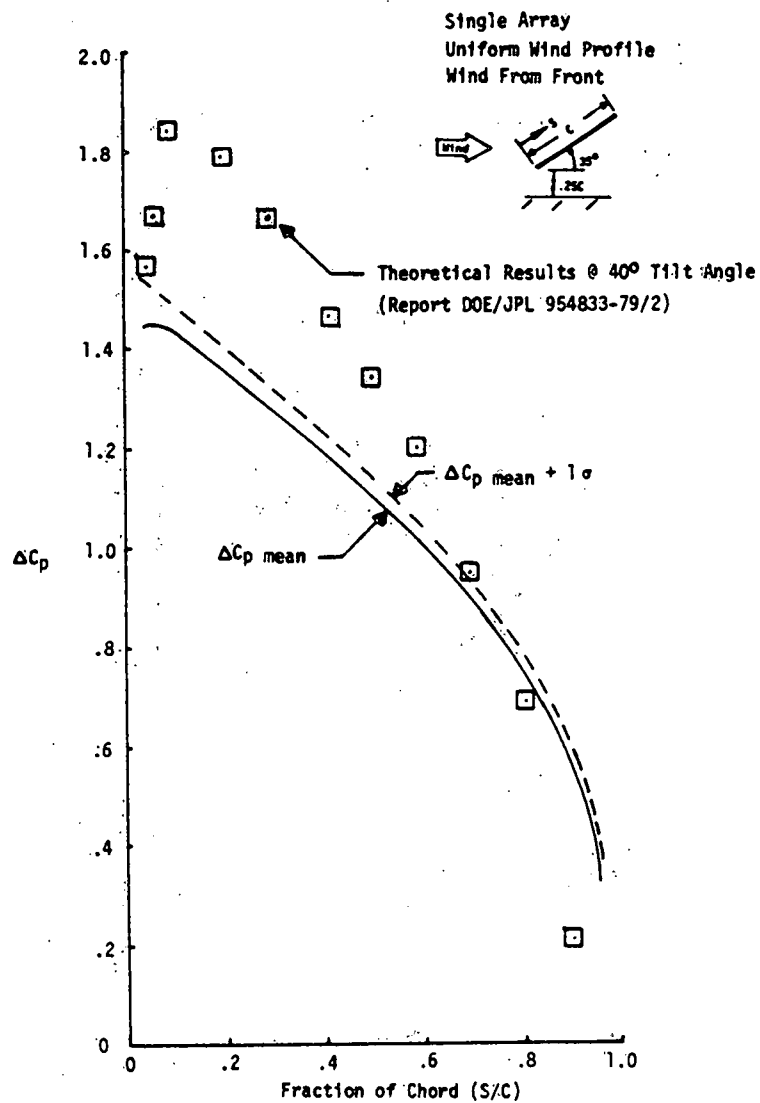

Figure 5-2b. Array Pressure Coefficient Distribution Comparison Between Wind Tunnel Test and Theoretical Methods In Close Ground Proximity (Tilt Angle = 35°)

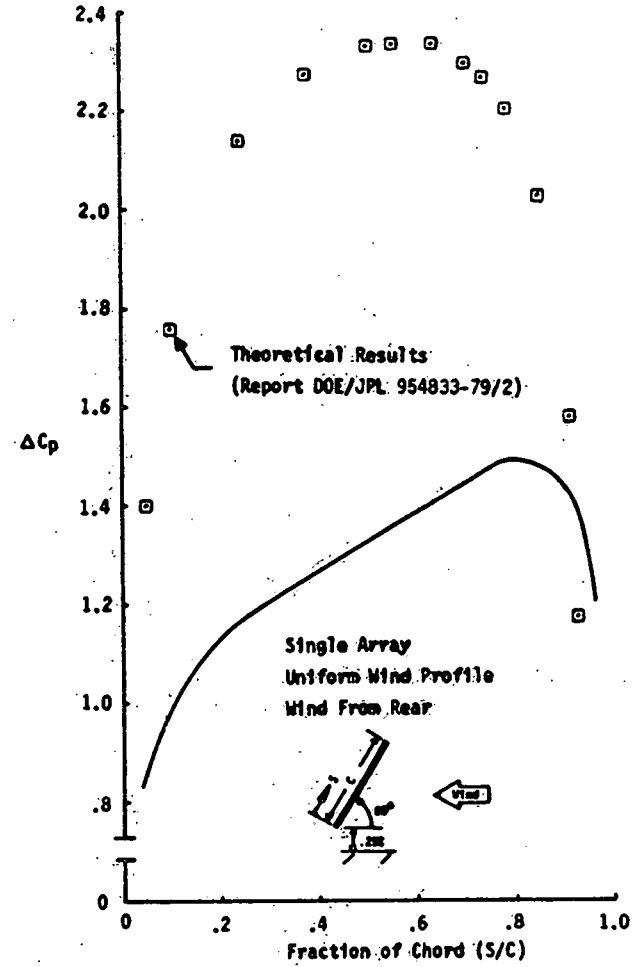
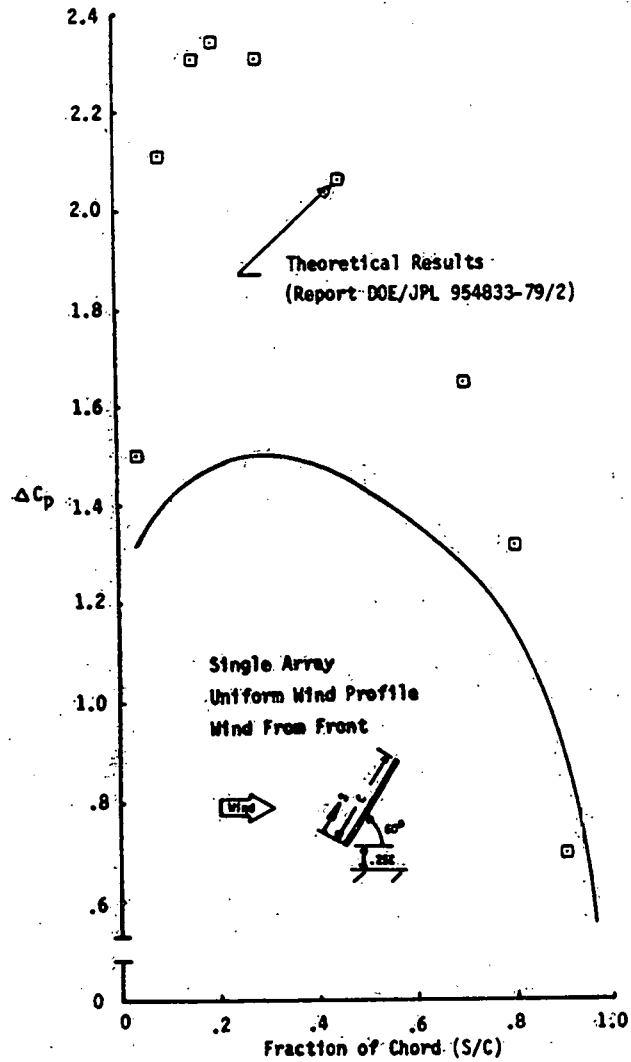
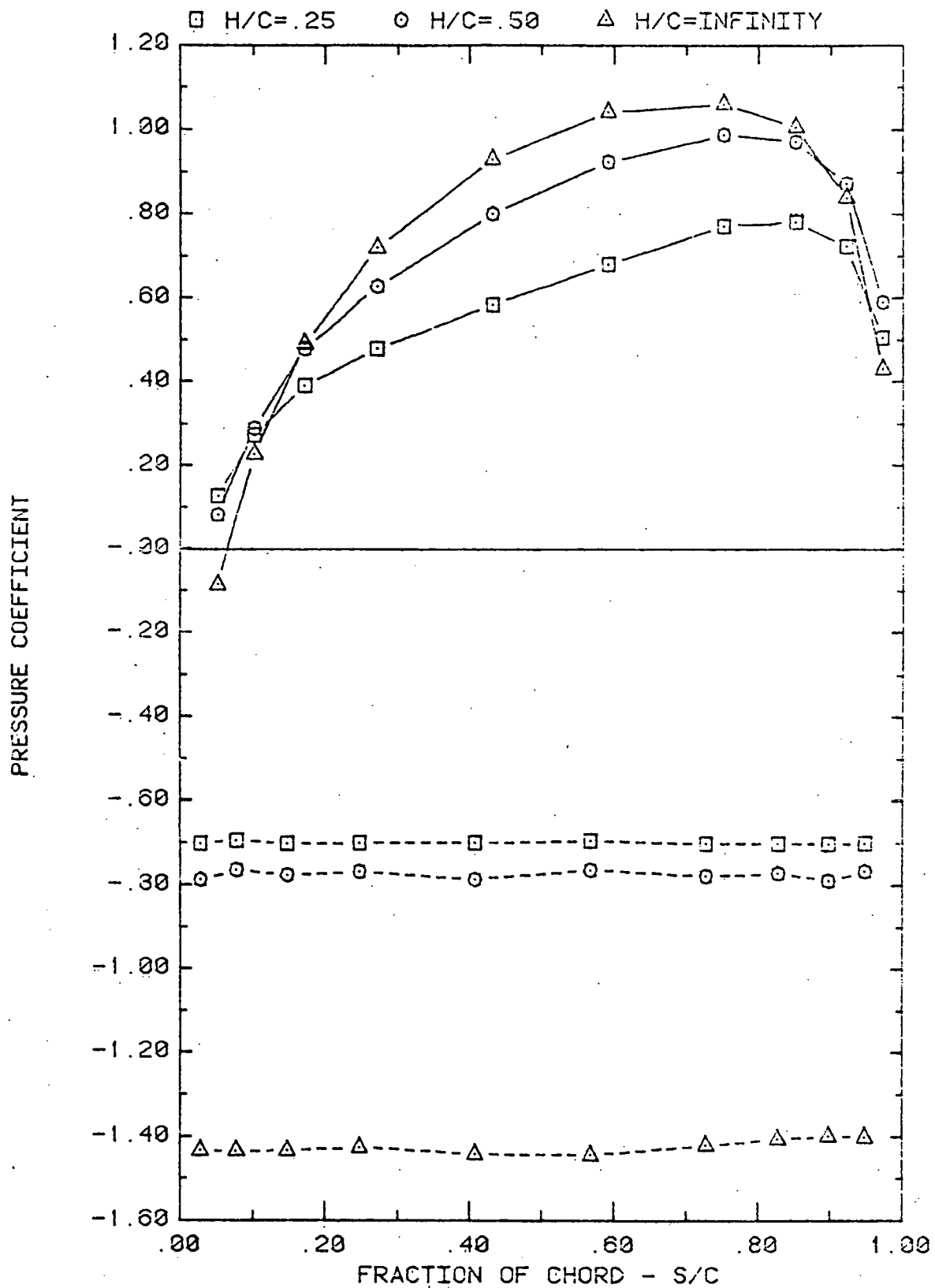

Figure 5-2c. Array Pressure Coefficient Distribution Comparison Between Wind Tunnel Test and Theoretical Methods in Close Ground Proximity (Tilt Angle = 60°)



FRONT AND BACK PRESSURES ON A SINGLE ARRAY IN UNIFORM FLOW.
EFFECT OF GROUND CLEARANCE FOR ATTACK ANGLE, $\alpha = 60^\circ$

Figure 5-3. Effect of Ground Clearance on Front and Back Array Pressures in Uniform Flow (Tilt Angle = 60° , Wind from Back)

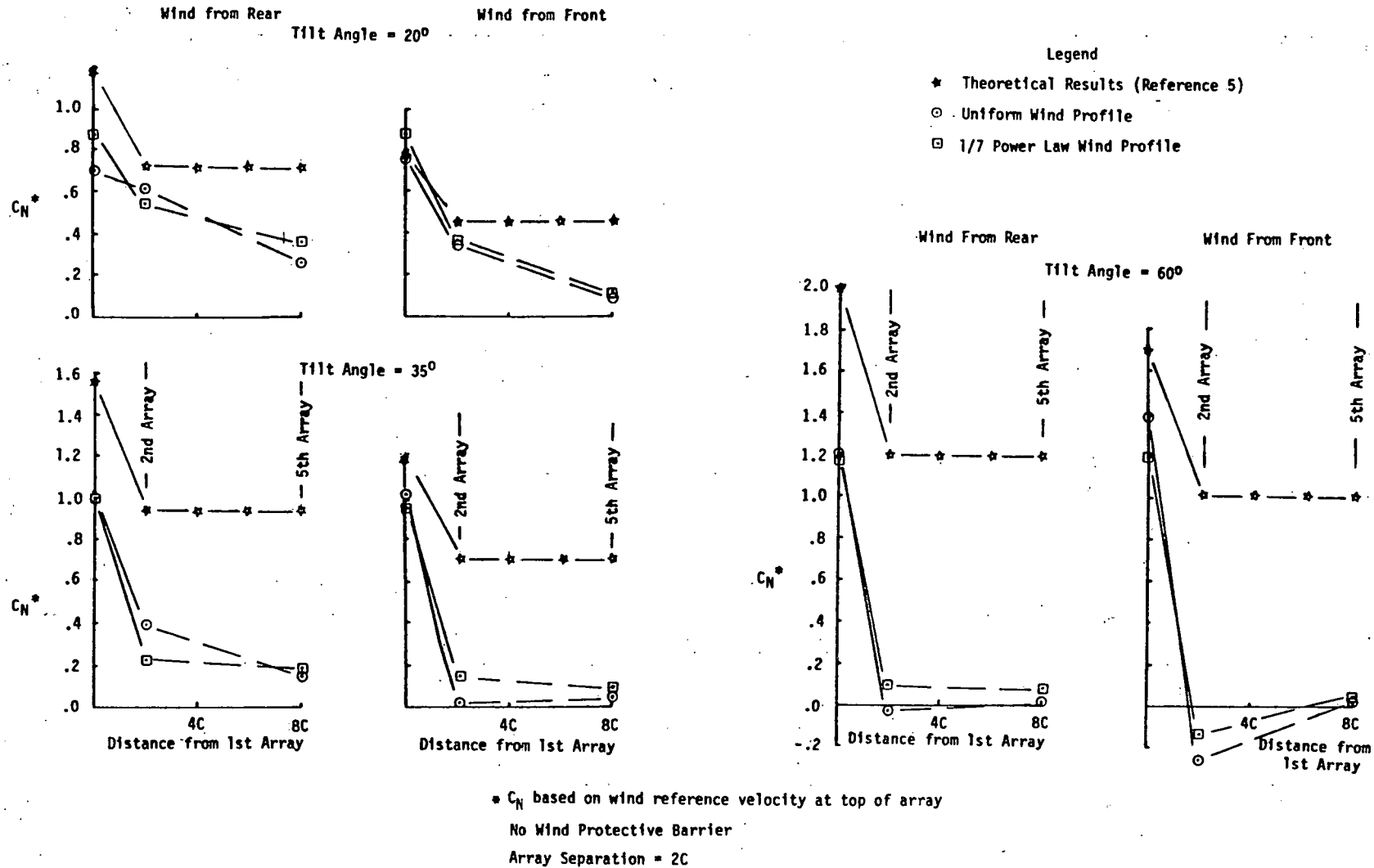

Figure 5-4. Array Normal Force Coefficient Comparison Between Wind Tunnel Test and Theoretical Methods

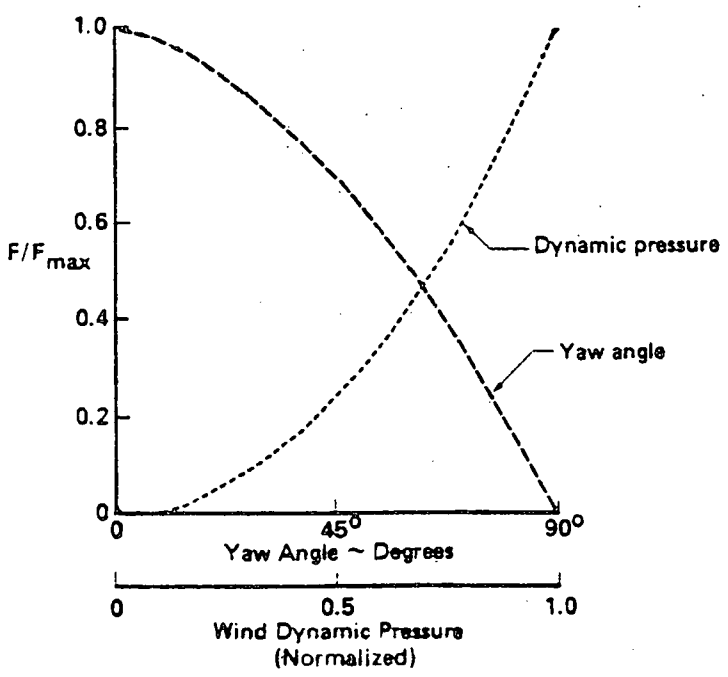
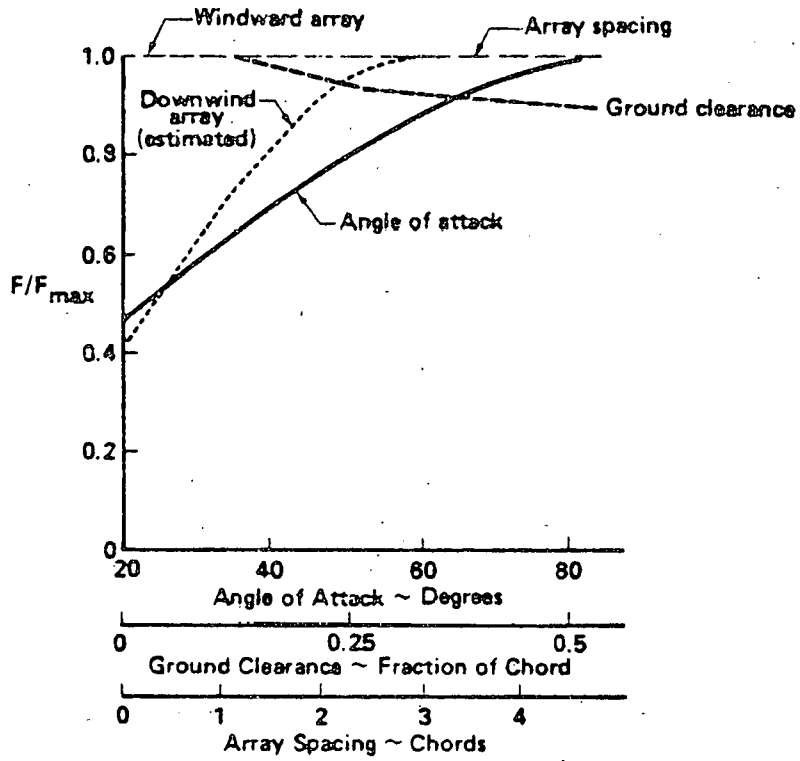

Figure 5-5. Theoretical Key Wind Loads Parameters and Their Sensitivity in Separated Flow Analyses (Reference 5)

6.0 DISCUSSION AND CONCLUSIONS

Currently, there are no known published data or results of wind loads from full sized photovoltaic arrays placed in the natural environment. The wind tunnel test utilizing the Meteorological Wind Tunnel and simulating the natural boundary layer wind as a $1/7$ power law wind profile is the closest simulation compared to theoretical methods or uniform wind tunnel simulations of arrays placed in the natural environment. Therefore, all results from the different analyses were compared to the results obtained from the wind tunnel test that simulated the wind boundary layer.

Theoretical methods to calculate pressures and forces on arrays positioned at tilt angles greater than fifteen to twenty degrees require the use of separated flow analysis techniques that are directly applicable only to single arrays with infinite aspect ratios. Thus, the results must be extrapolated or modified for the array edges, arrays positioned behind fences, and interior arrays in an array field as performed in reference 5. The theoretical array pressure distribution and normal force results for the windward array and interior arrays were shown to be conservative (over designed) compared to the boundary layer wind tunnel test. The theoretical normal force results for arrays positioned behind fences are fairly close but conservative for tilt angles less than 35° and become much more conservative for tilt angles near 60° . As a result, if theoretical means are used for determining steady state wind loads on photovoltaic arrays and for sizing the array structural members, the arrays will be overstrength for steady state wind loading.

Most previous wind tunnel tests have been conducted for various shapes of structure in uniform wind profiles and out of the ground effect. Normal force coefficients for flat plates, cylinders, and spheres are readily available in the literature for this condition. If the flat plate coefficients for plates out of the ground effect are used for arrays close to the ground, they will yield normal wind forces that are ultra conservative. If test results are obtained for flat plate arrays in an array field and in a uniform flow wind tunnel with the influence of the ground effect, the results are variable, some conditions are conservative and others unconservative. Consequently, the results from a uniform flow wind tunnel for flat plate arrays would require a factor of safety to be applied to assure that the results are conservative if

used in an absolute sense for design values. However, the results are adequate to be used for trade studies in preliminary design such as using load alleviation devices, etc.

The boundary layer wind tunnel test for the flat plate photovoltaic array field produced some interesting results and conclusions. A fence (or the first windward array, if no fence exists) protects the downwind arrays except near the array edges from the wind. The wind normal forces and pressures of these downwind arrays are several times smaller than the first windward array when no fence protects it. In addition, as the tilt angles of the arrays increase, the greater the wind protection received by the downwind arrays and the smaller the normal forces and pressures on the arrays. Wind direction (frontal or rearward) does not significantly affect the results. The normal forces and pressures on arrays positioned as close as three to four rows from the front have the same magnitude whether a fence protects the field or not. A fence will significantly lower the loads on the first array and can even lower the first array loads below the loads on the arrays within the field. Thus, a fence can actually overprotect the arrays close to the fence. If the fence to protect the arrays from wind is properly designed, all arrays could be designed for the wind loads experienced by the interior arrays.

The pressure distribution on arrays protected by a fence and/or within the array field are essentially flat, resulting in no pitching moment on the array. In contrast to this, the first and second array without a protective fence have varying pressure distributions. The first array has a pressure distribution typical of a single flat plate. The second array is affected considerably by the downwash and turbulence of the first array and may have a pressure distribution along a chord that changes from positive to negative pressures. Another noteworthy observation is that the pressure on the base pressure side is flat for all conditions except near the edges.

The wind loads on the array edges are considerably different from the remainder of the array field. Vortices are produced by array corners and fence corners and can produce very high wind loads at and near the array edges, depending on the wind direction. Pressure coefficients tend to be especially high in the localized leading edge-side edge area of the array. The high wind loads diminish to the loads within the array field at approximately two slant height distances from the edge, again depending on the wind direction. Several means

to alleviate the wind loads at the edges were presented in Section 4 but even the reduced edge loads are still several times the array mid-span loads.

In the wind tunnel test, the fluctuating pressures were recorded for a finite time, averaged to obtain the steady state loads and the rms value of the variable loads calculated to obtain indications of the level of the pressures produced by the array generated turbulence. The actual rms values will be larger than those recorded because of the damping inherent in the data acquisition. However, the rms load values do give an indication of the turbulence. In general, from the test results, the front arrays received the most turbulence induced loads when a fence existed and the second arrays received the most when no fence existed.

For design purposes, envelopes of the normal force and pressure coefficients were developed, where applicable, to encompass the steady state loads for all tilt angles and wind directions. These design envelope loads are explained and presented in total in Section 7.0.

THIS PAGE
WAS INTENTIONALLY
LEFT BLANK

7.0 STEADY STATE WIND LOAD DESIGN GUIDELINES

Based on the results of the boundary layer wind tunnel test and the results of the theoretical study documented in reference 5, the following design guidelines are given for determining wind loading on photovoltaic flat plate arrays. The normal force and pressure coefficient guidelines were obtained by enveloping the results from the wind tunnel test and are valid for arrays with separations from 1.5C to 3.0C. Wind tunnel tests with the winds normal to the spanwise axis of the arrays were used for the guidelines. From the theoretical study and aerodynamic principles, winds normal to the spanwise axis will produce the maximum pressure loading on the arrays at locations at least two slant heights from the array side edges.

7.1 Wind Loads on Arrays Behind a Protective Wind Barrier

If a fence is used to protect the arrays in an array field, the steady state wind loading on the first arrays will be the same or less than the arrays within the field if the fence* is properly designed for wind protection. Figure 7-1a presents normal force coefficients for conditions where the first array is protected from wind loading at least as well as the arrays interior to the field. This figure can be used to calculate steady state wind forces on arrays and array supporting structure in an array field. These loads are not applicable for the structure within two slant heights from the edge. The steady state normal wind force on the array is calculated by the equation:

$$F_N = q S C_{N1} \quad - - - - (1)$$

*The fence used in this study had a porosity of 30% and a height equal to three-quarters of the array slant height. Since this study did not investigate other fence configurations, it is the designer's responsibility to assure that his fence design produces as much wind protection as the fence used in this study. There are several papers referred to in reference 5 that investigate the effects of fence porosity on the wind velocity behind the fence. In general, a porosity of from 30% to 50% produces the best wind protection. A solid fence tends to increase the turbulence compared to a higher porosity fence and also causes reversed flow behind the fence. The height of the fence is less critical than fence porosity on array loads provided that the height of the fence is near or above the array height.

where:

F_N = Steady state normal force (lbs)

q = Dynamic pressure (psf) for reference design velocity at 10 meters

S = Area of array (ft²)

$$C_{N1} = K_1 C_N$$

= Corrected normal force coefficient

C_N = Normal force coefficient from figure 7-1a

K_1 = Scale factor to correct for array size

$$= \left(\frac{C \sin \alpha + H_0}{8 \sin \alpha + 2} \right)^{.28}$$

C = Array slant height (ft)

H_0 = Ground clearance (ft)

α = Tilt angle (degrees)

The scale factor (K_1) corrects (in an approximate manner) the wind forces for arrays whose slant height and ground clearance are different than the test array baseline size of 8 ft. slant height and 2 ft. ground clearance. This scale factor considers the difference in the wind velocity at the top of an array whose size and position is different from the baseline array relative to the wind velocity at the top of the baseline array.

Figure 7-1b presents steady state pressure coefficients normalized to the normal force coefficients at corresponding tilt angles. The steady state pressure distributions on the arrays behind a fence are essentially constant or vary linearly (increasing from the trailing edge to the leading edge) for all tilt angles. The pressures can be calculated by the equation:

$$P = qC_{p1} \text{ - - - - (2)}$$

where:

p = Steady state local pressure loading (psf)

q = Dynamic pressure (psf) for reference design velocity at 10 meters

$$C_{p1} = K_1 C_p$$

= Corrected pressure coefficient

K_1 = Scale factor to correct for array size and ground clearance

$$= \left(\frac{C \sin \alpha + H_0}{8 \sin \alpha + 2} \right)^{.28}$$

C = Array slant height (ft)

H_0 = Ground clearance (ft)

α = Tilt angle (degrees)

$\frac{C_p}{C_N}$ = Normalized pressure coefficient from figure 7-1b

C_N = Normal force coefficient from figure 7-1a

The steady state pressure loading is valid for all flat plate array panels in an array field except for panels within two slant heights from the edge. Where leading edge (L.E.) and trailing edge (T.E.) are given, the pressure loading is assumed as linearly increasing from the trailing edge value to the leading edge value. It should be noted that some conservatism is designed into the panel pressure loading by assuming a flat or linearly varying pressure coefficient. This conservatism can be seen in the normalized pressure coefficient shown in Figure 7-1. If the pressure coefficient distribution was matched exactly, the C_p/C_N curve would be equal to 1.0. Thus, conservatism of from 10 to 20% is built into the pressure loading by simplifying the distribution.

The use of these design guidelines can best be illustrated by the following example:

1. Determine the design normal force and pressure distribution on an array interior to an array field for a 90 mph wind approaching the front of the array and at sea level. The array slant height is 8 feet, ground clearance is 2 feet, span is 10 feet, and the tilt angle is 30 degrees.

q = wind dynamic pressure at 10 meter height

$$= .5 \rho V^2$$

$$= .5 (.002378)(131.23)^2$$

$$= 20.5 \text{ psf}$$

S = area of array

$$= 8 \times 10$$

$$= 80 \text{ ft}^2.$$

$$\begin{aligned}
 K_1 &= \text{Scale factor} \\
 &= \left(\frac{8 \sin(30^\circ) + 2}{8 \sin(30^\circ) + 2} \right)^{.28} \\
 &= 1.0
 \end{aligned}$$

$$C_N = .16 \text{ from figure 7-1a}$$

$$\begin{aligned}
 C_{N1} &= K_1 C_N \\
 &= .16
 \end{aligned}$$

To calculate the normal force

$$\begin{aligned}
 F_N &= q S C_{N1} \\
 &= 20.5 \times 80 \times .16 \\
 &= 262.4 \text{ lbs. force normal to the array (30}^\circ \text{ from vertical) and in downward} \\
 &\quad \text{direction per figure 7-1a}
 \end{aligned}$$

To calculate the pressure distribution along the chord

$$\begin{aligned}
 p &= q C_{p1} \\
 C_{p1} &= K_1 \frac{C_D}{C_N} C_N
 \end{aligned}$$

From figure 7-1b

$$\frac{C_D}{C_N} = 1.18 \text{ at trailing edge (top edge for wind from front)}$$

$$= 1.26 \text{ at leading edge (bottom edge for wind from front)}$$

$$C_N = .16 \text{ from figure 7-1a}$$

$$K_1 = 1.0$$

therefore

$$\begin{aligned}
 C_{p1} &= 1.18 \times .16 \\
 &= .19 \text{ trailing edge}
 \end{aligned}$$

$$\begin{aligned}
 \text{and } C_{p1} &= 1.26 \times .16 \\
 &= .20 \text{ leading edge}
 \end{aligned}$$

The local pressure is

$$\begin{aligned}
 p &= 20.5 (.19) \\
 &= 3.9 \text{ psf at trailing edge (downward direction per figure 7-1b)} \\
 p &= 20.5 (.20) \\
 &= 4.1 \text{ psf at leading edge (downward direction per figure 7-1b)}
 \end{aligned}$$

Therefore, the pressure varies on the panel from 4.1 psf at the leading edge (lower edge) to 3.9 psf at the trailing edge (upper edge) for a 90 mph wind approaching the front of the array field.

7.2 Wind Loads on Arrays Without a Protective Wind Barrier

If an array field is to be designed without a protective fence, the first two arrays from the front and back need to be designed for larger wind loads than in Section 7.1. All remaining arrays interior to these two front arrays can be designed to withstand wind loads given in Figure 7-1. The maximum normal wind forces on the first two arrays from the front and back of the array field can be calculated similarly to those in Section 7.1 using the normal force coefficient envelope and the delta pressure coefficient presented in Figure 7-2a and b. As an example:

1. Calculate the normal force and pressure on the first array for the same conditions as in the example in 7.1.

To calculate the normal force:

From before

$$q = 20.5 \text{ psf}$$

$$S = 80. \text{ ft}^2$$

$$K_1 = 1.0$$

From figure 7-2a

$$C_N = .65$$

Therefore the normal force on the array is

$$F_N = 20.5 \times 80 \times .65$$

$$= 1066 \text{ lbs in downward direction per figure 7-2a}$$

To calculate the panel pressure.

$$\frac{C_p}{C_N} = 0.8 \text{ at trailing edge}$$

$$= 1.28 \text{ at leading edge}$$

$$C_N = .65$$

$$p = 20.5 \times 0.8 \times .65$$

$$= 10.7 \text{ psf at trailing edge}$$

$$= 20.5 \times 1.28 \times .65$$

$$= 17.1 \text{ psf at leading edge}$$

Therefore, the pressure varies from 17.1 psf at the leading edge to 10.7 psf at the trailing edge with the pressure in downward direction per figure 7-2b.

7.3 Array Edge Wind Loads

The wind loads within two slant heights from the side edges have a different character than those within the array field because of the corner vortices. This test program was primarily directed towards the wind loads within an array field and only a limited amount of testing was devoted to the edge loads. Consequently, a comprehensive set of wind load guidelines for the edge loads cannot be detailed from the test data. However, the following normal force coefficients and pressure coefficients are given as guidelines and can be used in the design of the edge arrays if the following design conditions are satisfied.

Array tilt angle $\approx 35^\circ$

Fence design details, if applicable, as footnoted in Section 7.1

Fence corner modifications, if applicable, as shown in configuration 5,

Figure 4-16

The normal force coefficients and delta pressure coefficients for arrays within two slant heights from the side edge of the array field and for three field configurations - no fence, fence, and fence with the corners modified - are shown

in Figures 7-3a to 7-3c. These coefficients are based on the test data located .15 chord lengths from the side edge. Since the loads decrease with distance in from the edge, these coefficients are conservative if used over the two slant heights from the side edge. In addition, the pressure distributions show high pressure coefficients located within 5% to 10% from the upper edge. Since a structural support is likely to be located on the leading and trailing edges to support the arrays, these high pressure loads, within 10% of the top edge, may not be critical to the design of the panels and may not need to be considered in their design. The effect of this high pressure loading is in the normal force coefficient calculation which is a parameter used to size the supporting structure.

The application of these coefficients is similar to the examples shown in Section 7.1 and 7.2, except that C_p replaces $\left(\frac{C_p}{C_N}\right)(C_N)$ in the examples.

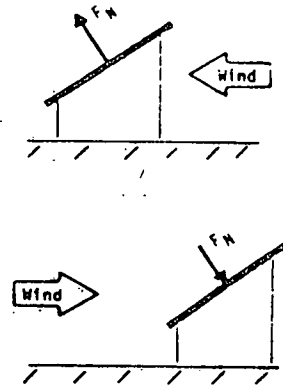
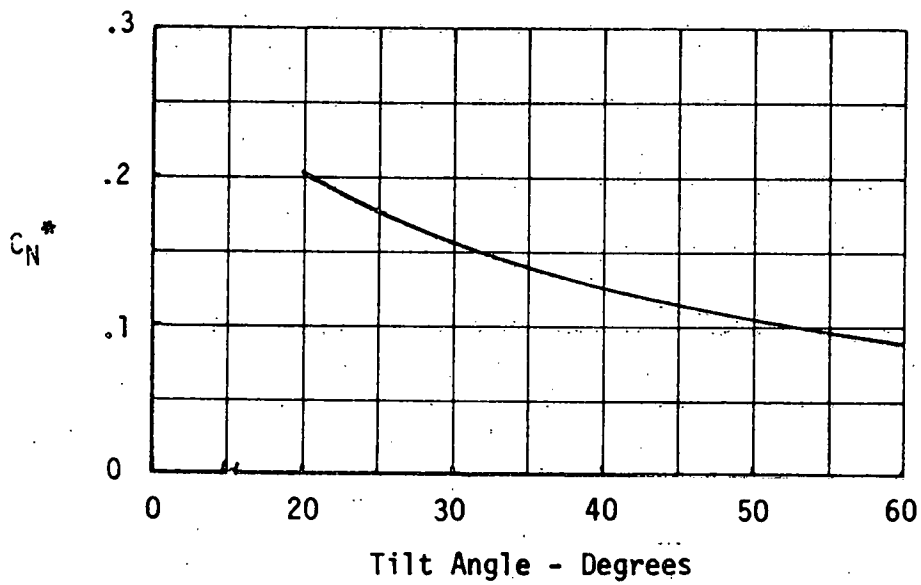

* C_N based on wind reference velocity at 10 meters

exception: not valid within two slant heights from the side edges

Figure 7-1a. Steady State Wind Normal Force Coefficient Envelope for Arrays Within an Array Field or Behind a Protective Wind Barrier.

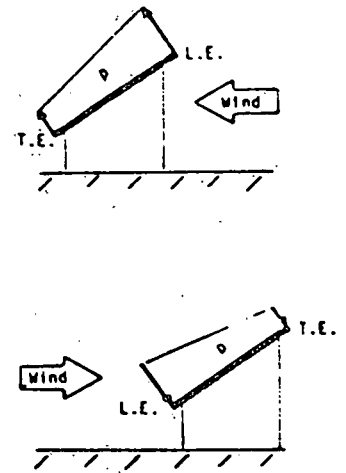
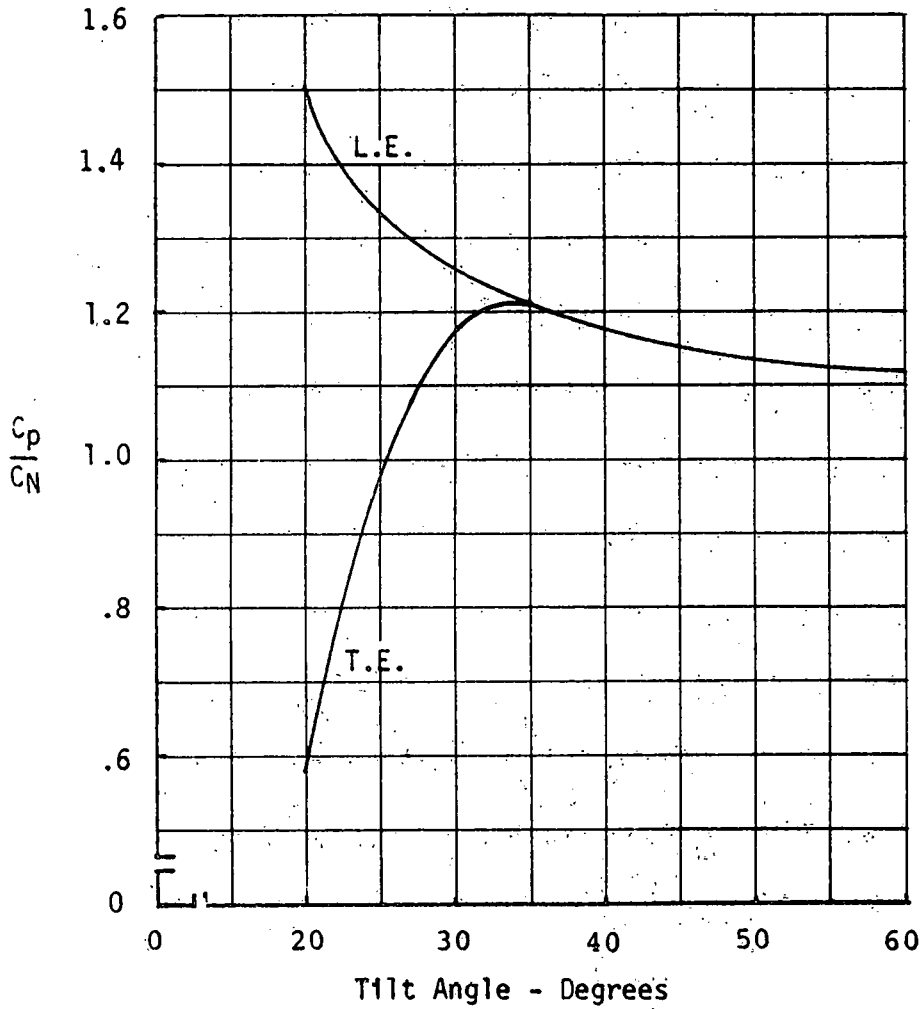

exception: not valid within two slant heights from the side edges

Figure 7-1b. Steady State Wind Normalized Pressure Coefficient Envelope for Arrays Within an Array Field or Behind a Protective Wind Barrier

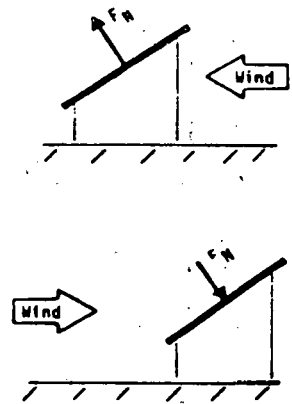
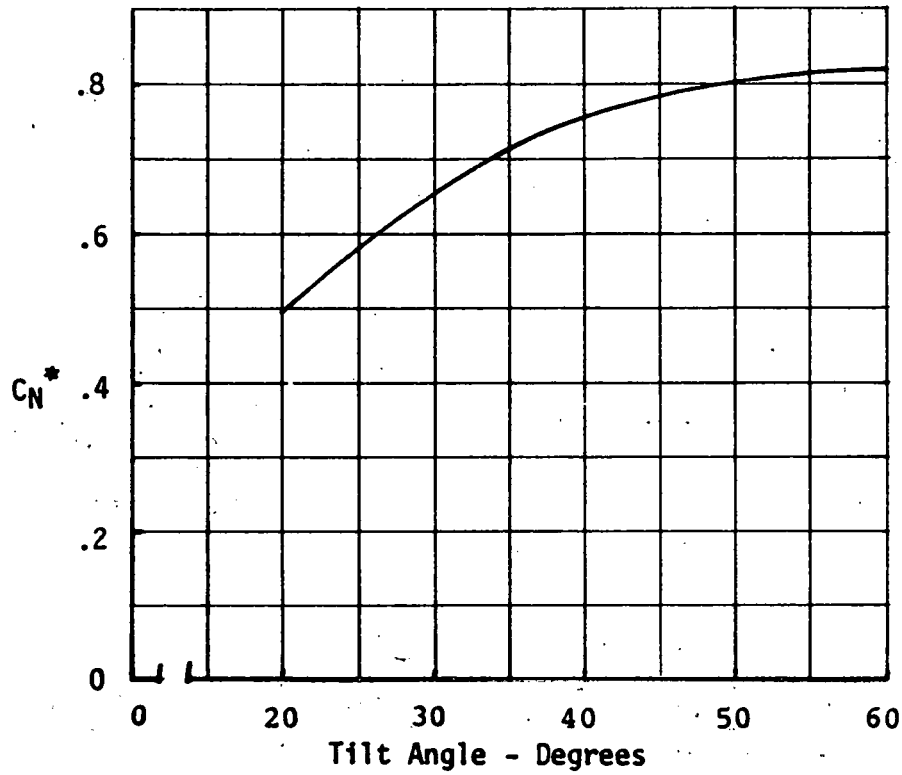

* C_N based on wind reference velocity at 10 meters
 exception: not valid within two slant heights from the side edges

Figure 7-2a. Steady State Wind Normal Force Coefficient Envelope for the Two Outer Boundary Array Rows in an Array Field Unprotected from the Wind

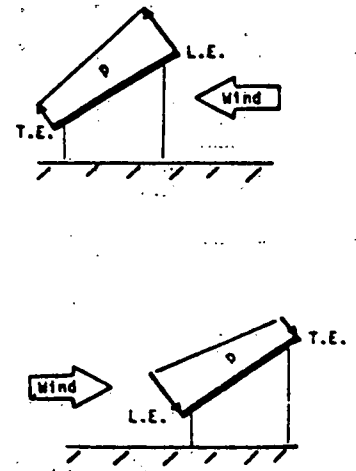
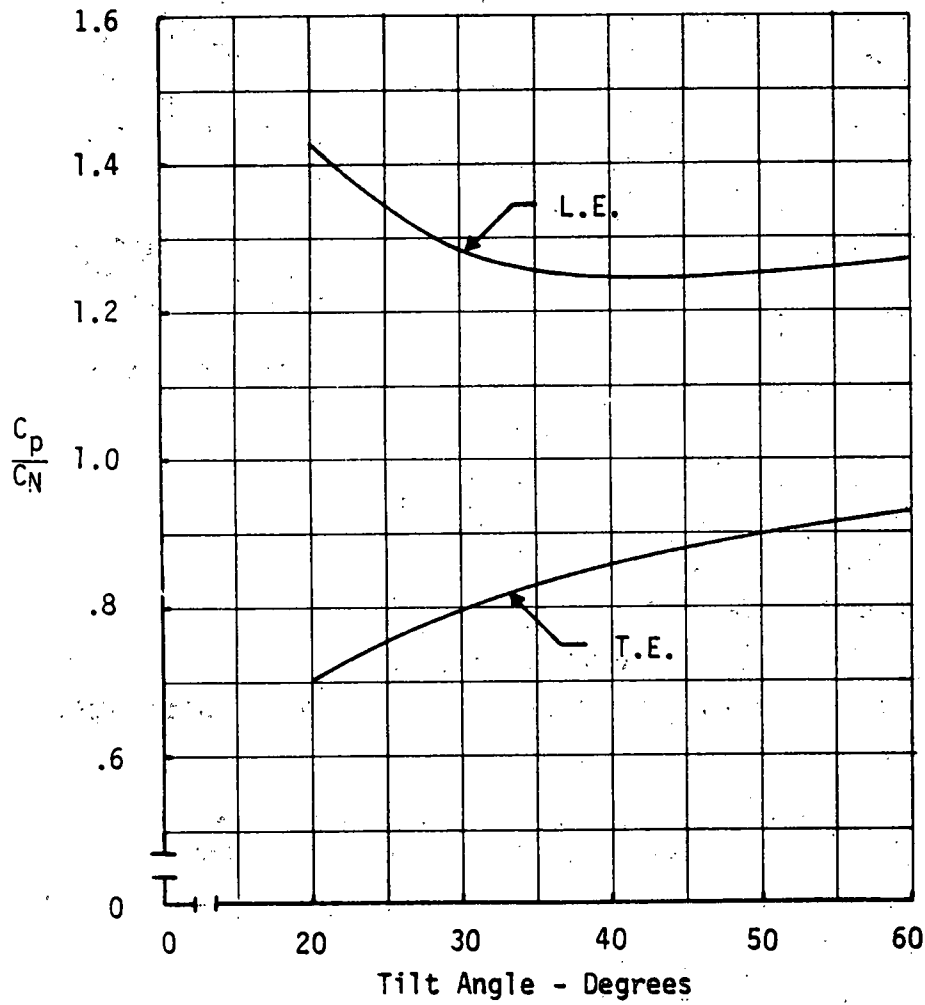

exception: not valid within two slant heights from the side edges

Figure 7-2b. Steady State Wind Normalized Pressure Coefficient Envelope for the Two Outer Boundary Array Rows in an Array Field Unprotected from the Wind

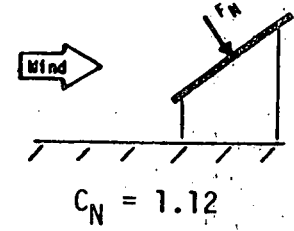
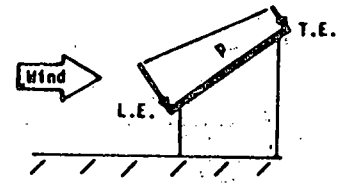
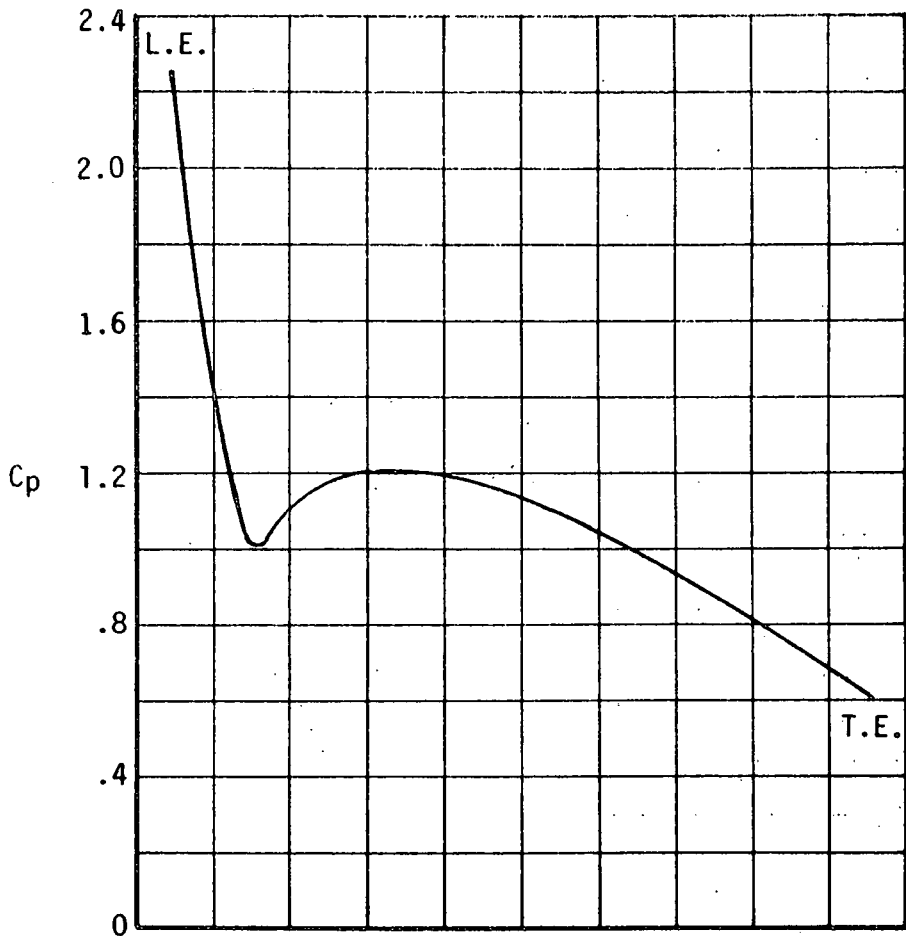

Based on:
 Tilt Angle = 35°
 Wind reference velocity
 at 10 meters

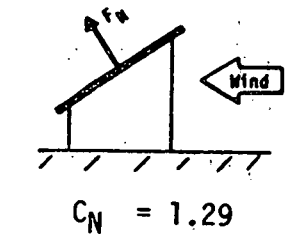
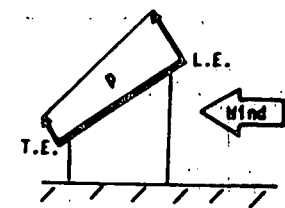
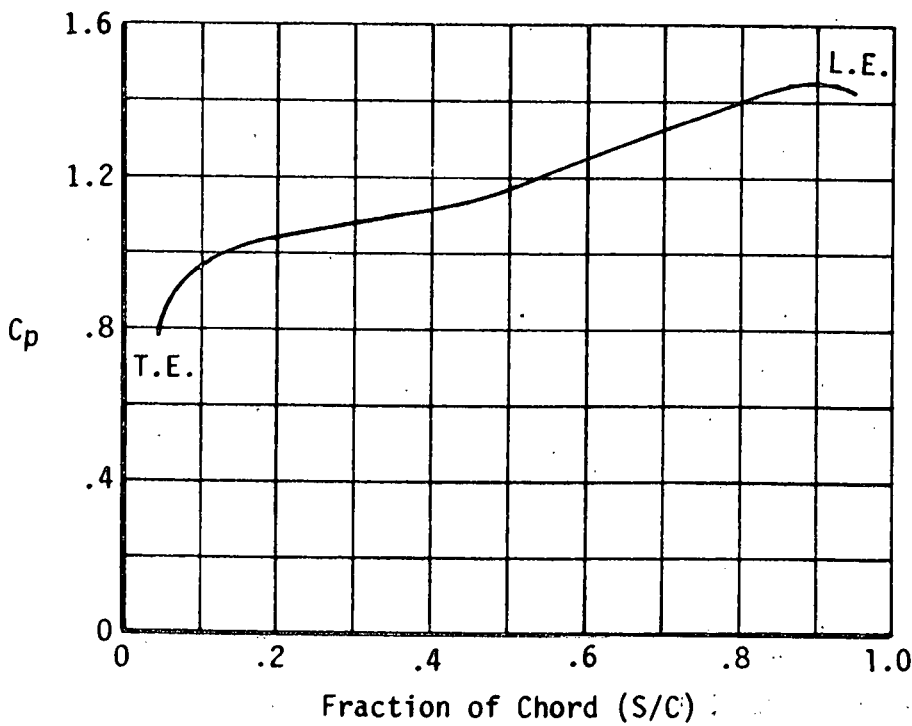
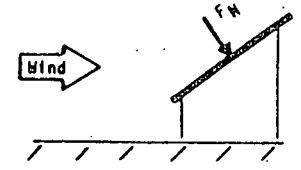
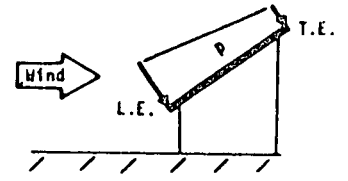
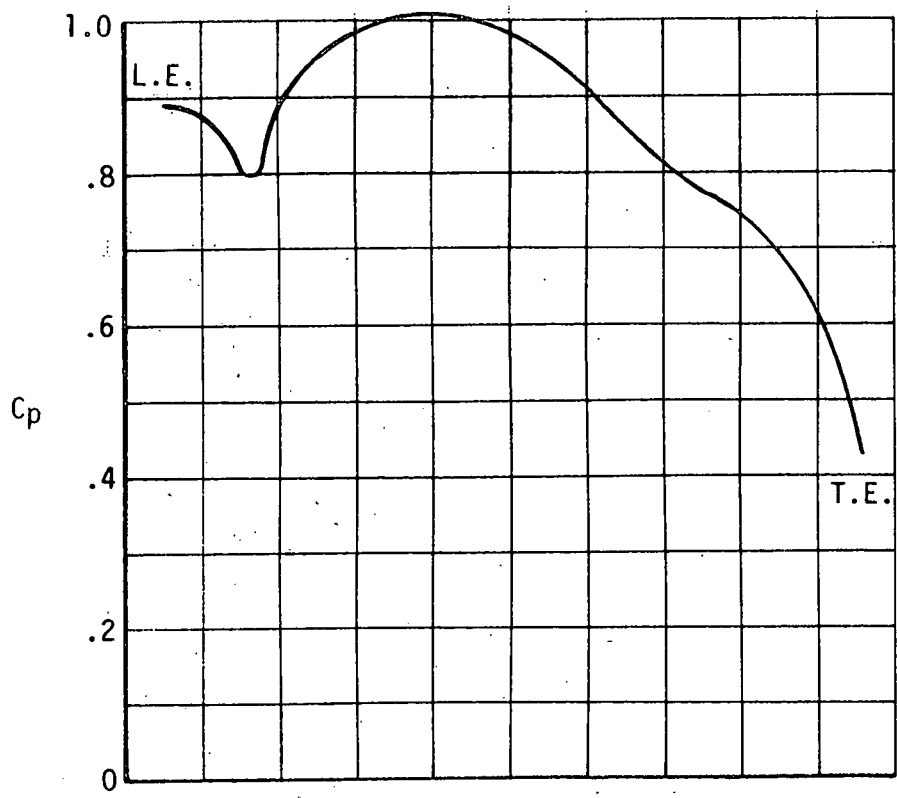
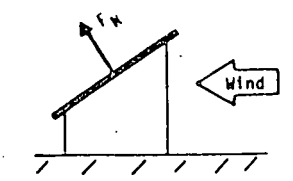
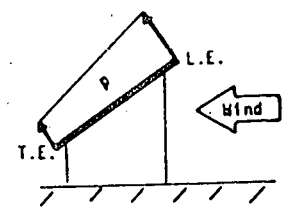
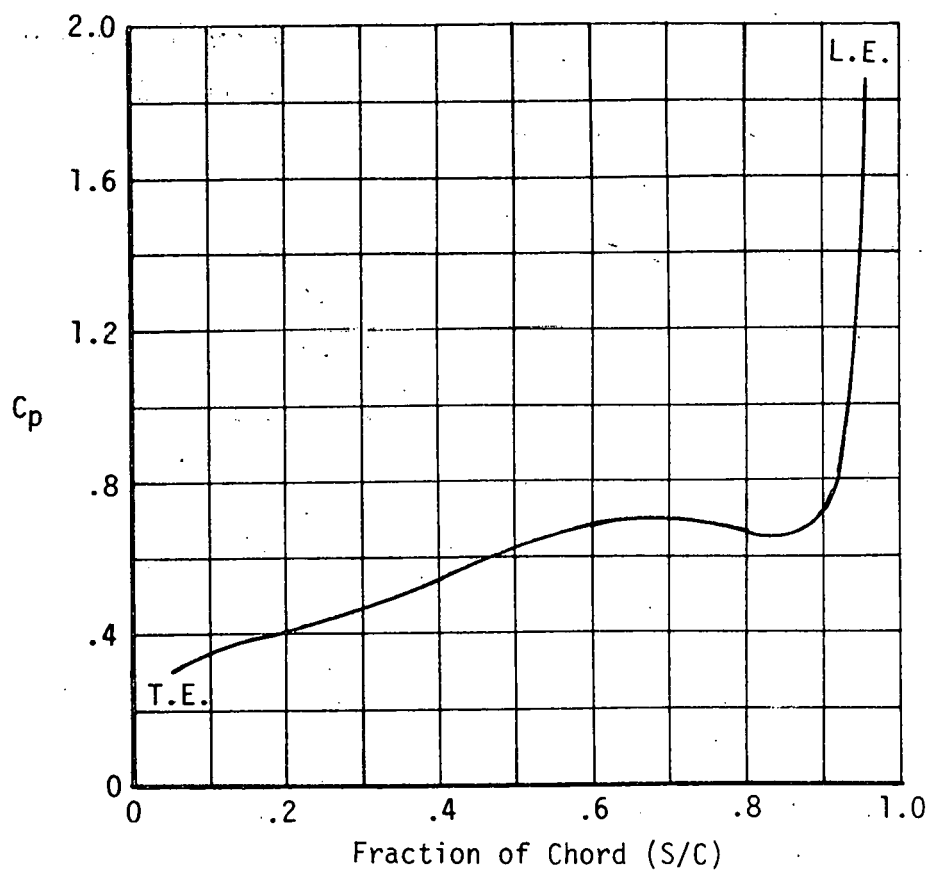

Figure 7-3a. Steady State Wind Pressure Coefficient and Normal Force Coefficient Guidelines for Edge Arrays in an Array Field (No Fence)



$C_N = .88$

Based on:
 Tilt Angle = 35°
 Wind reference velocity
 at 10 meters



$C_N = .66$

Figure 7-3b. Steady State Wind Pressure Coefficient and Normal Force Coefficient Guidelines for Edge Arrays in an Array Field (Fence)

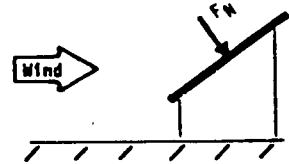
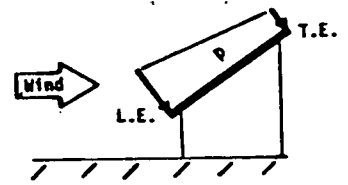
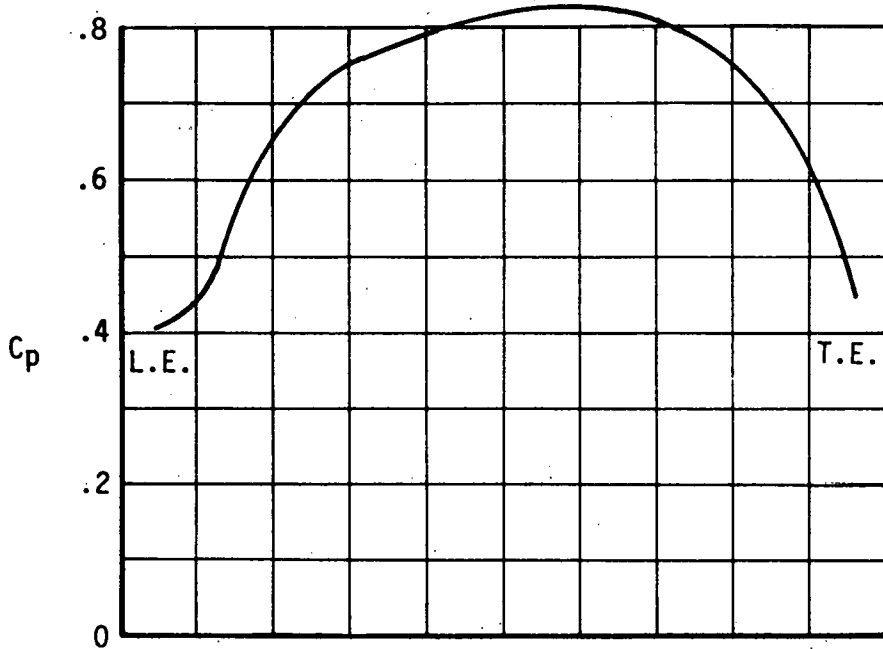

$$C_N = .68$$

Based on:
 Tilt Angle = 35°
 Wind reference velocity
 at 10 meters

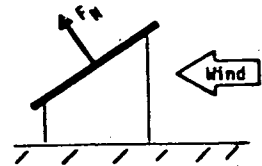
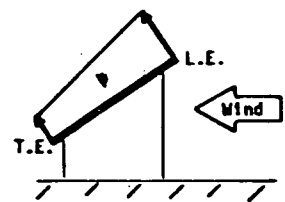
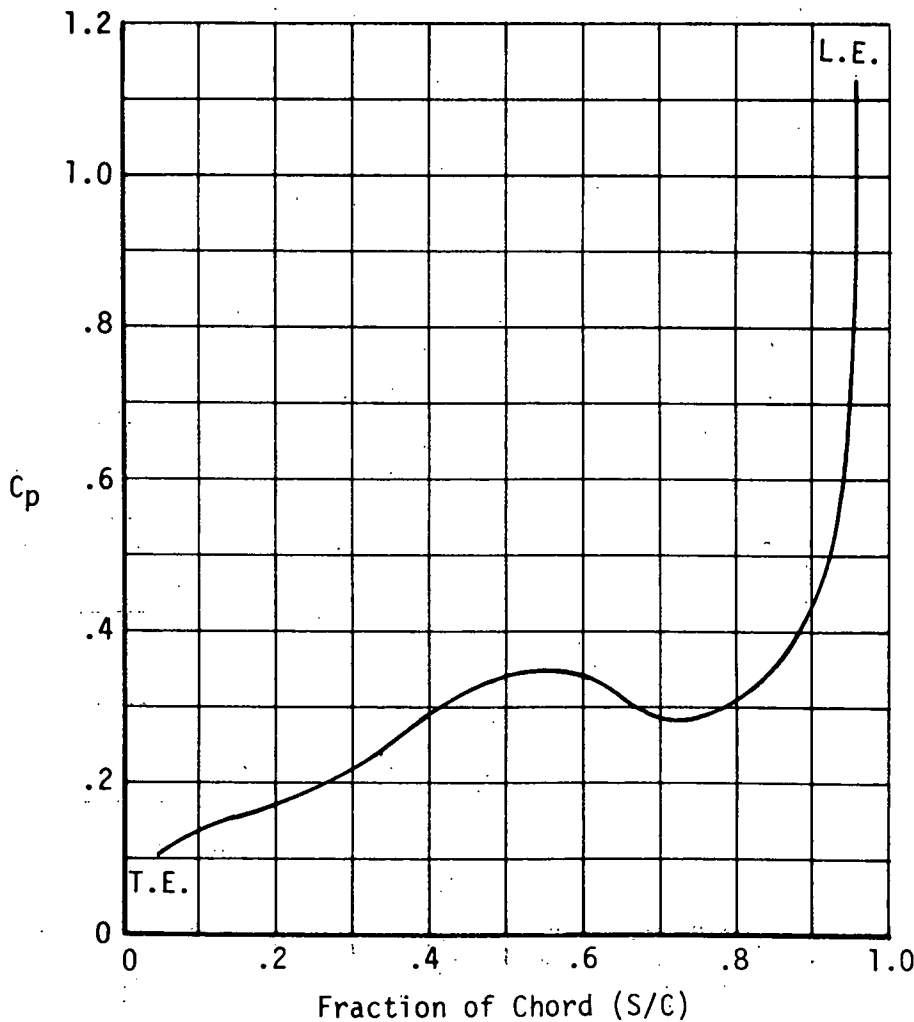

$$C_N = .32$$

Figure 7-3c. Steady State Wind Pressure Coefficient and Normal Force Coefficient Guidelines for Edge Arrays in an Array Field (Fence with Modified Corners)

8.0 NEW TECHNOLOGY

No reportable items of new technology have been identified by Boeing during the contract of this work.

THIS PAGE
WAS INTENTIONALLY
LEFT BLANK

9.0 REFERENCES

1. National Photovoltaic Program, Program Plan, February 3, 1978, U.S. Department of Energy, Division of Solar Technology.
2. "Module/Array Interface Study," DOE/JPL-No. 954698-78/1, Bechtel National, Inc., Research and Engineering Operation, August, 1978.
3. "Feasibility Study of Solar Dome Encapsulation of Photovoltaic Arrays," DOE/JPL-No. 954833-78/1, Boeing Engineering and Construction Company, December, 1978.
4. A. G. Davenport, "Rationale for Determining Design Wind Velocities," Proceedings of the American Society of Civil Engineers, Vol. 86, No. ST5, May, 1960.
5. "Wind Loads on Flat Plate Photovoltaic Array Fields," DOE/JPL-No. 954833-79/2, Boeing Engineering and Construction, September, 1979.

THIS PAGE
WAS INTENTIONALLY
LEFT BLANK

APPENDIX

WIND LOADS ON FLAT PLATE
PHOTOVOLTAIC ARRAY FIELDS

PHASE III - FINAL REPORT

WIND TUNNEL TEST REPORT

Prepared for Jet Propulsion Laboratory
under Contract No. 9654833

Boeing Engineering and Construction Company
A Division of The Boeing Company)
Seattle, Washington 98124

WIND PRESSURES AND FORCES ON
FLAT-PLATE PHOTOVOLTAIC SOLAR ARRAYS

by

N. Hosoya,* J. A. Peterka,** M. Poreh,***

and J. E. Cermak****

for

Boeing Engineering and Construction Company
P. O. Box 3707
Seattle, Washington 98124

Fluid Dynamics and Diffusion Laboratory
Civil Engineering Department
Colorado State University
Fort Collins, Colorado 80523

September 1980

*Graduate Research Assistant

**Associate Professor

***Professor

****Professor-in-Charge, Fluid Mechanics
and Wind Engineering Program

CER80-81NH-JAP-MP-JEC13

THIS PAGE
WAS INTENTIONALLY
LEFT BLANK

TABLE OF CONTENTS

	<u>Page</u>
LIST OF FIGURES	v
LIST OF TABLES	viii
LIST OF SYMBOLS	x
1. INTRODUCTION	A-1
2. EXPERIMENTAL CONFIGURATION	A-3
2.1 Wind Tunnel	A-3
2.2 Flow Simulation	A-3
2.3 The Models	A-6
3. INSTRUMENTATION AND DATA ACQUISITION	A-8
3.1 Measurements of Flow Characteristics	A-8
3.2 Pressure Measurements	A-9
3.3 Normal Force Calculations	A-9
4. PRESENTATION AND ANALYSIS OF THE EXPERIMENTAL DATA	A-11
4.1 Single Array Tests	A-11
4.2 Array Field Tests	A-13
4.3 Flow Visualization	A-14
5. CONCLUSIONS	A-16
6. REFERENCES	A-17
FIGURES	A-18
TABLES	A-58

THIS PAGE
WAS INTENTIONALLY
LEFT BLANK

LIST OF FIGURES

<u>Figure</u>		<u>Page</u>
1	Meteorological Wind Tunnel	A-19
2	Array Field Models in Meteorological Wind Tunnel	A-20
3	Mean Velocity and Turbulence Distribution in Nonuniform Flow	A-21
4	One Dimensional Velocity Spectra in Nonuniform Flow	A-22
5	Turbulence Spectra in Nonuniform Flow (BL1) Compared to Atmospheric Spectra	A-23
6	Mean Velocity and Turbulence Distribution in Uniform Flow	A-24
7	Typical Horizontal Velocity Distribution across Meteorological Wind Tunnel	A-25
8	1:12 Scale Models in Meteorological Wind Tunnel	A-26
9	Photograph of Standard Corner Fence	A-27
10	Position of Pressure Taps on Instrumented Model	A-28
11	Schematic Description of Array Field	A-29
12	Front and Back Pressures on a Single Array in Uniform Flow, $WD = 0^\circ$, $H/c = 0.25$, $\alpha = 20^\circ$, 35° , 60° and 90°	A-30
13	Front and Back Pressures on a Single Array in Uniform Flow, $WD = 0^\circ$, $H/c = 0.25$, $\alpha = 120^\circ$, 145° and 160°	A-31
14	Front and Back Pressures on a Single Array in Uniform Flow, $WD = 0^\circ$, $H/c = \text{infinity}$, $\alpha = 20^\circ$, 30° , 60° and 90°	A-32
15	Absolute Values of Normal Force Coefficients on a Single Array in Uniform Flow, $WD = 0^\circ$	A-33
16	Front and Back Pressures on a Single Array in Nonuniform Flow, $WD = 0^\circ$, $H/c = 0.25$, $\alpha = 20^\circ$, 35° , 60° , and 90°	A-34

LIST OF FIGURES (Cont.)

<u>Figure</u>		<u>Page</u>
17	Front and Back Pressures on a Single Array in Nonuniform Flow, $WD = 0^\circ$, $H/c = 0.25$, $\alpha = 120^\circ$, 145° and 160°	A-35
18	Absolute Values of Normal Force Coefficient on a Single Array in Nonuniform and Uniform Flows, $WD = 0^\circ$, $H/c = 0.25$	A-36
19	Normal Force Coefficients for an Array Field in Uniform Flow, $WD = 0$, $x/c = 2.0$, $H/c = 0.25$, No Fence	A-37
20	Normal Force Coefficients for an Array Field with a Fence of Various Height and Porosity, $WD = 0^\circ$, $x/c = 2.0$, $H/c = 0.25$, $\alpha = 35^\circ$	A-38
21	Normal Force Coefficients for an Array Field with a Fence of Various Height and Porosity, $WD = 0^\circ$, $x/c = 2.0$, $H/c = 0.25$, $\alpha = 145^\circ$	A-39
22	Corner Fence Configurations	A-40
23	Normal Force Coefficients for an Array Field with Various Fence Configurations, $WD = 45^\circ$, $x/c = 2.0$, $H/c = 0.25$, $MC = 0$	A-41
24	Model Configurations	A-42
25	Normal Force Coefficients for an Array Field with Various Model Configurations, $WD = 45^\circ$, $x/c = 2.0$, $H/c = 0.25$, $FC = 1$	A-43
26	Normal Force Coefficients for an Array Field in Nonuniform Flow, No Fence, $WD = 0^\circ$, $H/c = 0.25$, $\alpha = 20^\circ$, 35° , 60° and 90°	A-44
27	Normal Force Coefficients for an Array Field in Nonuniform Flow, No Fence, $WD = 0^\circ$, $H/C = 0.25$, $\alpha = 120^\circ$, 145° and 160°	A-45
28	Normal Force Coefficients for an Array Field with Various Fences, $WD = 0^\circ$, $x/c = 2.0$, $H/c = 0.25$, Nonuniform Flow	A-46
29	Normal Force Coefficients for an Array Field, Edge and Corner Studies, $x/c = 2.0$, $H/c = 0.25$, Nonuniform Flow	A-50

LIST OF FIGURES (Cont.)

<u>Figure</u>		<u>Page</u>
30	Normal Force Coefficients for an Array Field, Corner Study with Various Fence and Model Configurations, $x/c = 2.0$, $H/c = 0.25$, Nonuniform Flow	A-52
31	Flow Visualization for an Array Field, $WD = 0^\circ$	A-54
32	Flow Visualization for an Array Field, $WD = 45^\circ$	A-57

LIST OF TABLES

<u>Table</u>		<u>Page</u>
1	Normal Force and Maximum Pressure Difference for a Single Array in Uniform Flow	A-59
2	Normal Force and Maximum Pressure Difference for an Array Field in Uniform Flow, $x/c = 2.0$	A-60
3	Normal Force and Maximum Pressure Difference for an Array Field in Uniform Flow, $x/c = 1.5$ and 3.0	A-61
4	Normal Force and Maximum Pressure Difference for a Single Array in Nonuniform Flow	A-62
5	Normal Force and Maximum Pressure Difference for an Array Field in Nonuniform Flow, $x/c = 2.0$	A-63
6	Normal Force and Maximum Pressure Difference for an Array Field in Nonuniform Flow, $x/c = 1.5$ and 3.0	A-64
7	Normal Force and Maximum Pressure Difference for an Array Field with a Fence, $H_f/c = 0.75$, $P_f = 30\%$, $x_f/c = 1.25$	A-65
8	Normal Force and Maximum Pressure Difference for an Array Field with a Fence, $H_f/c = 0.75$, $P_f = 30\%$, $x_f/c = 2.5$	A-66
9	Normal Force and Maximum Pressure Difference for an Array Field with a Fence, $H_f/c = 0.75$, $P_f = 30\%$, $x_f/c = 5.0$	A-67
10	Normal Force and Maximum Pressure Difference for an Array Field with a Fence of Various Height and Porosity	A-68
11	Normal Force and Maximum Pressure Difference for an Array Field, Edge Study	A-69
12	Normal Force and Maximum Pressure Difference for an Array Field, No Fence, Corner Study	A-70
13	Normal Force and Maximum Pressure Difference for an Array Field with Various Fences, Corner Study	A-71

LIST OF TABLES (continued)

<u>Table</u>		<u>Page</u>
14	Normal Force and Maximum Pressure Difference for an Array Field with Various Fences, MC = 1, Corner Study	A-72
15	Normal Force and Maximum Pressure Difference for an Array Field with Various Models, FC = 1 and 4, Corner Study	A-73
16	Normal Force and Maximum Pressure Difference for an Array Field with a Fence, $H_f/c = 1.0$, $\alpha = 60^\circ$ and 120°	A-74
17	Fence Configurations	A-75
18	List of Test Configurations	A-76

LIST OF SYMBOLS

<u>Symbol</u>	<u>Definition</u>
c	chord length of solar array
C_N	normal force coefficient
C_p	pressure coefficient
ΔC_{pmax}	maximum pressure difference
D	characteristic length in Reynolds number
FC	fence configuration
$F(N)$	velocity spectrum
h	ground clearance of solar array
H_{af}	height of additional fence
H_f	height of fence
H_s	height of spoiler
MC	model configuration
N	frequency
P	pressure
P_{af}	porosity of additional fence
P_f	porosity of spoiler
q_∞	dynamic pressure measured outside simulated boundary layer
q_{ref}	reference dynamic pressure
s	chordwise position--the edge where $s = 0$ corresponds to the leading edge for $\alpha \geq 90^\circ$ and the trailing edge for $\alpha < 90^\circ$
s_{max}	chordwise position where maximum pressure difference is observed
U	velocity of wind
U_{ref}	reference velocity of wind
U_{rms}	variance of fluctuating velocity

LIST OF SYMBOLS (Cont.)

<u>Symbol</u>	<u>Definition</u>
U_{δ}	velocity of wind at simulated boundary layer height
U_{∞}	velocity of wind measured outside simulated boundary layer
x	separation distance of solar array
x_f	separation distance between fence and solar array
α	angle of attack of solar array
δ	height of simulated boundary layer
ν	kinematic viscosity of air
ρ	density of air

1. INTRODUCTION

An important factor influencing the design and subsequently cost of large photovoltaic power generating systems, which involve a large number of simple structural elements and supports, is the magnitude of wind-induced loads. It has been recognized that usual design procedures, like the ANSI code (A58.1 - 1972) for example [1], are not adequate for accurate wind design of these repetitive, photovoltaic arrays with their distinctive configuration, orientation and limited height. In fact, the information presently available in the technical literature is not sufficient even for an optimum design of the structure for supporting a single photovoltaic array. Wind loads on individual arrays at different locations in a large array field are more difficult to determine as they vary according to the array location in the field and wind direction in a complicated manner. Higher loads are expected to exist at the edges of the field, but those can be reduced by carefully designed fences or barriers.

A theoretical study of the aerodynamics of flat plate arrays was recently made by Ronald D. Miller and Donald Zimmerman [2] at the Boeing Engineering and Construction Company (BECC). The study identified the basic features of the flat plate array loading which can be used for design purposes. It has been recognized by the authors, however, that theoretically derived design criteria are conservative and a wind-tunnel study of the wind loadings of such arrays was therefore recommended.

This report describes the experimental study of wind loading on flat plate photovoltaic arrays and array fields performed in the Meteorological Wind Tunnel of the Fluid Dynamics and Diffusion Laboratory at Colorado State University for BECC. The experimental program was developed in cooperation with Ronald D. Miller (BECC). The program's objectives were to determine the pressure distribution and forces acting on photovoltaic arrays for different angles of attack, two wind directions, head on winds and cornering winds ($WD = 0^\circ$ and 45° as defined in Figure 11) and two velocity profiles, as well as to investigate the effect of different fences and barriers on the wind loading at the edges and corners of an array field.

The wind-tunnel results were analyzed and the effect of the various parameters are presented in a form permitting calculation of the wind loading on prototype photovoltaic structures.

In view of the large number of data points collected in the report, it was found convenient to present most of the pressure measurements in a separate Appendix. The main report includes, however, a full description of the various runs and the calculated values of the normal force coefficient, the maximum local pressure coefficient and its location for each run in a tabulated form (Table 1 to 16) as well as a graphical representation of these data.

2. EXPERIMENTAL CONFIGURATION

2.1 Wind Tunnel

The Meteorological Wind Tunnel of the Fluid Dynamics and Diffusion Laboratory at Colorado State University (Figure 1) is characterized by a long (96 ft), slightly diverging test section, 6 ft-8 in. wide (at the turntable) and 6 ft high. The ceiling is adjustable to avoid pressure gradient along the test section. This facility is driven by a 400 HP variable pitch propeller with air flow velocity varying continuously from 0.5 fps up to 100 fps.

2.2 Flow Simulation

The primary consideration in modeling wind forces on structures in a wind tunnel is that the wind characteristics in the tunnel simulate natural boundary-layer winds at the actual site. In general this requires that the vertical distribution of mean velocity and turbulence in the wind tunnel boundary layer match those at the site and that the Reynolds numbers of the model and the prototype be equal. In addition, the small-scale model must be geometrically similar to its prototype. A detailed discussion of these requirements and their implementation in the wind-tunnel environment can be found in references 3, 4, and 5.

The construction of a 1:24 scale model of a prototype structure and its immediate surroundings (in this case, a flat, open area), submerged in a turbulent boundary layer of the Meteorological Wind Tunnel, shown in Figure 1, satisfies all the above criteria except those of equal Reynolds numbers and similarity of turbulence intensity and scale.

The kinematic viscosity ν appearing in the Reynolds number UD/ν is the same for both the tunnel and the full-scale structure. Because of this, the wind-tunnel air speed, U , would have to be 24 times the full-scale value if the model and prototype Reynolds numbers are to be equal. Testing at such high wind speeds is not feasible. However, for Reynolds numbers larger than 2×10^4 for sharp-edged structures where the flow separation point is fixed, there is no significant change in the values of aerodynamic coefficients as the Reynolds number increases. Since typical Reynolds number values are 10^6 - 10^7 for high-wind, full-scale flow and about 5×10^4 for wind-tunnel flows, acceptable flow similarity is achieved without equality of Reynolds numbers.

At a model scale of 1:24, the larger scales of turbulence in the atmospheric boundary layer are not simulated in the wind-tunnel flow. However, because the integral scale of the turbulence in the wind tunnel was 2 to 3 times the largest dimension of the model collector, the influence of the scale of turbulence is not expected to be significant [6]. Evidence exists which demonstrates some influence of turbulence intensity on drag of flat plates [6,7,8]. Because the turbulence intensity difference between the current simulation and a simulation with complete similarity of turbulent structure is not large, the effects due to turbulence intensity should be small. For cases where an upstream collector disturbs the approach flow, turbulence characteristics are dominated by the wake characteristics of the upstream object and possible differences due to turbulence intensity should further decrease.

An important factor which affects the wind loadings is the structure of the atmospheric boundary layer near the ground. The boundary layer which develops over a flat terrain is usually characterized by a non-uniform velocity profile which is closely described by a 1/7th power law mean velocity distribution. It is impossible to simulate in a wind tunnel the entire atmospheric boundary layer at the desired model scale for this study (1:24). One can, however, simulate the lower part of the atmospheric boundary layer in a 45 in. deep wind tunnel boundary layer [3-5].

The shape of the 1/7th power law boundary layer, which will be referred to as the Nonuniform flow 1 was obtained by means of selected roughness on the wind-tunnel floor upstream of the model. Forty ft of test section length were covered with 1 in. cubes followed by a 40 ft length of pegboard with 0.25 in. diameter pegs projecting 0.5 in. above the pegboard base (see Figure 2). In addition to the floor roughness, four triangular spires were installed at the test section entrance in order to get a thicker boundary layer than would otherwise be obtained. The normalized velocity and turbulence profiles of this boundary layer are shown in Figure 3 and data is tabulated in the Appendix. Turbulence intensity is the root-mean-square of the longitudinal fluctuating velocity divided by the local mean velocity. The turbulence intensity reached values of 20 percent in the boundary layer.

The spectrum of longitudinal velocity fluctuations is shown in Figures 4 and 5, including two suggested analytical models of velocity spectra for the atmosphere by Harris (9) and Davenport (10).

The spectra were obtained at 4 and 8 in. above the wind-tunnel floor. In this plot N is frequency, $F(N)$ is the velocity spectrum, U_{rms}^2 is the variance of the fluctuating velocity, δ is the simulated boundary layer height (900 ft full-scale), and U_δ is the velocity at δ . The region where turbulence structure may be important to the determination of mean loading ranges upward from abscissa values of about 20 for wind speeds up to about 30 mph at 30 ft. Thus, the simulation has a turbulence intensity somewhat too high in the frequency range affecting mean wind loading on the model and too low in the low-frequency gusts.

The "Uniform Flow" velocity profile was obtained by placing the model at the upstream end of the test section. The measured velocity profile at that station, shown in Figure 6, indicates that a very thin boundary layer has developed along the short upstream section. Its effect on the wind loading on elevated panels is expected, however, to be small. A typical velocity distribution across the tunnel is shown in Figure 7.

2.3 The Models

Aluminum models of the flat photovoltaic array field having a geometrical scaling of 1:24 (Figure 2) and 1:12 (Figure 8) were constructed. (The 1:12 model was used in a limited number of tests only).

The chord size of the 1:24 model was $c = 4$ in., corresponding to a prototype value of 8 ft. Rows of pressure taps were drilled on each face of the array as shown in Figure 10. Each pressure tap represents the average pressure along a small section of the chord. The row at the edge of the array was used to study the wind loading at the side edge of the field.

To study the wind loadings on an array located in an array field, 1:24 scale models of array rows were constructed, which could be placed on the wind tunnel floor at desired locations to simulate the relative position in the field on the array with the pressure taps on which the wind loading was measured. Figure 2 shows a photograph of a 1:24 model of a photovoltaic array field in the wind tunnel. Figure 8 shows a photograph of the 1:12 model.

The fence was simulated in the model by perforated sheet metal, with holes of $3/16$ in. diameter, having the same porosity (about 30 percent) as the prototype fence (see Figure 9).

3. INSTRUMENTATION AND DATA ACQUISITION

3.1 Measurements of Flow Characteristics

Velocity and turbulence intensity profiles for the approach flow under test conditions were made at the locations of the model in the tunnel (turntable) with the model removed.

The measurements were made with a Thermosystems Model 1050 constant-temperature anemometer with a 0.001 in. diameter platinum film sensing element 0.02 in. long. The sensing probe was attached to a vertical traverse to measure velocities and turbulent intensities at different heights. Output was processed through the Laboratory on-line digital data acquisition system.

Tests were made at only one wind speed in the tunnel around 50 ft/sec. This wind was sufficiently high to ensure Reynolds number similarity between the model and prototype.

The reference velocity at each test was measured using a pitot-static tube which was connected to a Setra differential pressure transducer. The pitot tube was placed outside the simulated boundary layer and recorded the value of $q_{\infty} = \rho U_{\infty}^2 / 2$, where ρ is the mass density of the air. The ratio of the reference velocity U_{ref} , at a prototype height of 10 m above the ground, to U_{∞} was determined from the velocity distribution of the boundary layer according to the scale of the model. The value

$$q_{ref} = \frac{\rho U_{ref}^2}{2} = \frac{\rho U_{\infty}^2}{2} \left(\frac{U_{ref}}{U_{\infty}} \right)^2 \quad (1)$$

at the height corresponding to 10 m above ground in the prototype was later used in calculating the dimensionless force and moment coefficients of the array, so that it was not necessary to measure the density of the air.

3.2 Pressure Measurements

Each pressure tap was connected through a pressure switch to a calibrated Setra differential transducer which measured the value of the local pressure above the ambient pressure at the test section away from the model. The output from the pressure transducers was recorded for 16 seconds at a 250 sample per second rate. The data was then analyzed by a Hewlett-Packard System 1000 minicomputer under program control and recorded. The minicomputer calculated the local pressure coefficients and using the reference total value q_{ref} , at 30 ft prototype height,

$$C_p = \frac{P}{q_{ref}} \quad (2)$$

3.3 Normal Force Calculations

The local force per unit area acting on each section of the array is equal to the difference in the pressures measured at the center of that section on the opposite faces of the array. The magnitude of this pressure difference is

$$\Delta p(s) = P(s)_{\text{lower face of array}} - P(s)_{\text{upper face of array}} \quad (3)$$

where s designates the position of the section as defined in Figure 11. A positive value of $\Delta p(s)$ will thus correspond to a

normal net force per unit area with an upward component as shown schematically in Figure 11.

The dimensionless local pressure difference is defined as

$$\Delta C_p = \frac{\Delta P}{q_{\text{ref}}} \quad (4)$$

The maximum value of this coefficient, $\Delta C_{p_{\text{max}}}$ is of particular interest. The normal force N acting on the entire array can be calculated by integrating the value of $\Delta p(s)$ over the cord.

Similarly, the normal force coefficient C_N is given by

$$C_N = \frac{N}{c} = \frac{1}{c} \int_0^c \Delta C_p(s) ds \quad (5)$$

The direction of a positive normal force is shown in Figure 11. In most cases one would expect to find negative values of C_N for $\alpha > 90^\circ$.

4. PRESENTATION AND ANALYSIS OF THE EXPERIMENTAL DATA

4.1 Single Array Tests

Typical records of the pressure distribution on a single photovoltaic array for head-on winds ($WD = 0^\circ$) in the uniform flow are shown in Figures 12-14.* The solid lines in Figure 12 show the local pressure coefficient distributions on the upstream face of the panel. Positive values are usually recorded on the upstream face. The pressure coefficients on the downstream face, marked by dashed lines, are negative and hardly vary across the panel, indicating a flow separation, which was observed in the flow visualization study for both the single array and many of the arrays in an array field, see for example Figure 31. The shape of the pressure distribution curves on the upstream face of the panel is almost symmetric for $\alpha = 90^\circ$, but it becomes more and more skewed as the angle of attack decreases (Figure 12) or increases (Figure 13). Figure 14 shows the same data but for a large ground clearance, $H/c = \infty$ (actually measured at $H/c = 1.7$).

Comparing Figures 12 and 14 one finds that the pressure distribution on the upstream face of the panel is not affected to a large extent by the ground clearance. The back pressure, on the other hand, appears to change significantly. A value of $C_p \approx -1.35$ was recorded for $\alpha = 90^\circ$, $H/c = \infty$, whereas a value of $C_p = -0.75$ was recorded for the same angle of attack with a ground clearance of $H/c = 0.25$. This reduction of the back pressure reduces significantly the normal force acting on the plate. Figure 15 shows the absolute values of

*Unless explicitly stated, the data refers to the measurements at the center of the array (see Figure 10).

the normal force for all the single array tests in a uniform flow. Evidently, the same effect is apparent at all angles of attack.

The reduced drag at small ground clearances may be due to the changes in the wakes caused by the reduction in the eddy size downstream of the panel. It should be recalled that the approach velocities in these tests are independent of height. The complicated nature of the interaction between these eddies and the flow, which determine the base pressure, makes it difficult to predict the value of these pressures theoretically.

The pressure distributions on a single array ($H/c = 0.25$) in a nonuniform flow are shown in Figures 16 and 17. A clear reduction of the pressure coefficients relative to those in the uniform flow is observed. The corresponding absolute values of the normal force for the two cases are shown in Figure 18. The average ratio $C_N(\text{uniform})/C_N(\text{nonuniform})$ is $1.43 \pm 5\%$ for these tests. This large reduction is primarily due to the relatively small wind speeds at the height of the array for the nonuniform velocity profile. It should be recalled that q_{ref} is measured at the height of 10 m above the ground whereas the center of the panel, for this value of ground clearance, varies from 3.36 ft for $\alpha = 20^\circ$ to 6 ft for $\alpha = 90^\circ$. The corresponding ratios of $q_{\text{ref}}/q_{\text{center of panel}}$ for these cases in a 1/7th power law velocity distribution are 1.89 and 1.61 respectively. Obviously, the difference in the dynamic pressure of the free stream at the height of the panel alone cannot fully explain the observed changes. Comparing the ratio of the back pressures in the two cases, for example, one finds an average ratio

of almost 2, whereas the ratio of the pressure coefficients on the upstream face of the panel is only around 1.5. The shape of the corresponding pressure distribution curves is also different for the two cases.

4.2 Array Field Tests

A wide field of photovoltaic arrays is characterized by the separation distance, x/c , between the array (see Figure 11) and their angle of attack. The value of the normal force acting on each array depends, of course, on its position in the field.

Figure 19 shows the values of C_N for the 1st, 2nd and 5th arrays (from the upstream edge of the field) for head-on uniform winds.

The magnitudes of the normal force on array No. 1 are approximately equal to their values in a single array. A drastic reduction in the magnitude of the normal forces on the 2nd and 5th arrays is observed. In some cases the direction of the normal force is reversed.

The magnitude of the forces acting on the 1st array can be reduced by building a fence or a barrier (zero porosity fence) upstream of the field. The effect of the fence depends on its porosity, height and distance. Figure 20 shows the effect of a 30 percent porosity fence and a zero porosity fence on the magnitude of the normal forces acting on the 1st and 2nd rows for different fence heights, and for an angle of attack $\alpha = 35^\circ$. Similar results are obtained at different angles of attacks (see Figure 21).

The magnitude of the normal forces at the edge of an array, in case of head-on winds, is expected to be smaller than that of the forces acting on the center of the array. In case of side winds, however, the edges of the field and particularly the upstream corner will be exposed to higher loads. These forces can be reduced by a side fence and/or by different corner fence configurations. Figure 22 shows the corner fence configurations tested in this study. Their effect on the magnitude of the normal force for cornering winds is shown in Figure 23, which clearly exhibits the effect of properly designed fences on the normal forces at the field edges and corners.

Another way to reduce forces at the edge of the array field is to extend the array by an inexpensive stronger structure or by modifying the shape of the array edges. Several configurations, shown in Figure 24, have been studied. The fence configurations are also tabulated in Table 17. Their effect on the normal forces at the corner for $WD = 45^\circ$ is shown in Figure 25 for $\alpha = 35^\circ$ and $\alpha = 145^\circ$.

An overall view of the results and the effect of the various parameters on the normal forces is shown in Figures 26-30. Figures 26 and 27 show the effect of the distance between the arrays for different angles of attack. Figure 28 summarizes the fence study for head-on winds. Figures 29-30 show the effect of the corner fences and the modifications of the array edges. All test configurations investigated for this study are listed in Table 18.

4.3 Flow Visualization

Flow visualization was used in this study to explore the structure of the flow in the array field and to obtain a better understanding of the force and pressure measurements.

Figure 31a shows the wake behind the first array in the field and behind an array in the center of the field. Clear flow separation is observed for this angle of attack and spacing. Figures 31b and 31c show the structure and the nature of the flow at different points between the arrays.

Figure 32 shows two corner fence configurations and their effect on the flow structure near the fence.

5. CONCLUSIONS

Wind loadings on photovoltaic arrays in a large array field were measured on 1:24 and 1:12 scale wind-tunnel models. The dimensionless pressure and force coefficients measured are independent of the Reynolds number and can therefore be used for the design of prototype arrays.

Considerable differences were found between the normal force coefficients for uniform and nonuniform velocity fields. The arrays at the edges and corners of the field will usually be exposed to much larger forces than the arrays in the interior of the field. These forces can be considerably reduced, however, by fences and barriers. Data is presented which make it possible to design the prototype array field and fences for given atmospheric winds.

6. REFERENCES

1. American National Standards Institute, American National Standard Building Code Requirements for Minimum Design Loads in Buildings and Other Structures, ANSI Standard A58.1, 1972.
2. Miller, R. D. and Zimmerman, D., Wind Loads on Flat Plate Photovoltaic Array Fields, Boeing Engineering and Construction Report No. DOE/JPLG54833-79/2, Seattle, Washington 98124, September 1979.
3. Cermak, J. E., Aerodynamics of Buildings, Annual Review of Fluid Mechanics, Vol. 8, 1976.
4. Cermak, J. E., Laboratory Simulation of the Atmospheric Boundary Layer, AIAA Jl., Vol. 9, September 1971.
5. Cermak, J. E., Applications of Fluid Mechanics to Wind Engineering, A Freeman Scholar Lecture, ASME Jl. of Fluids Engineering, Vol. 97, No. 1, March 1975.
6. Bearman, P. W., Turbulence Effects on Bluff Body Mean Flow, Third U.S. National Conference on Wind Engineering Research, pp. 265-272, 1978.
7. Bearman, P. W., An Investigation of the Forces on Flat Plates Normal to a Turbulent Flow, Jl. Fluid Mechanics, Vol. 46, pp. 177-198, 1971.
8. Nakamura, Y. and Tomonari, Y., The Effect of Turbulence on the Drag of Rectangular Prisms, Transactions Japan Society of Aeronautical and Space Science, Vol. 19, pp. 81-86, 1976.
9. Harris, R. I., The Nature of the Wind, Modern Design for Wind Sensitive Structures, Paper 3, 1971.
10. Davenport, A. G., The Spectrum of Horizontal Gustiness Near the Ground, Quarterly Jl., Royal Meteorological Society, Vol. 81, pp. 194-211, 1961.

FIGURES

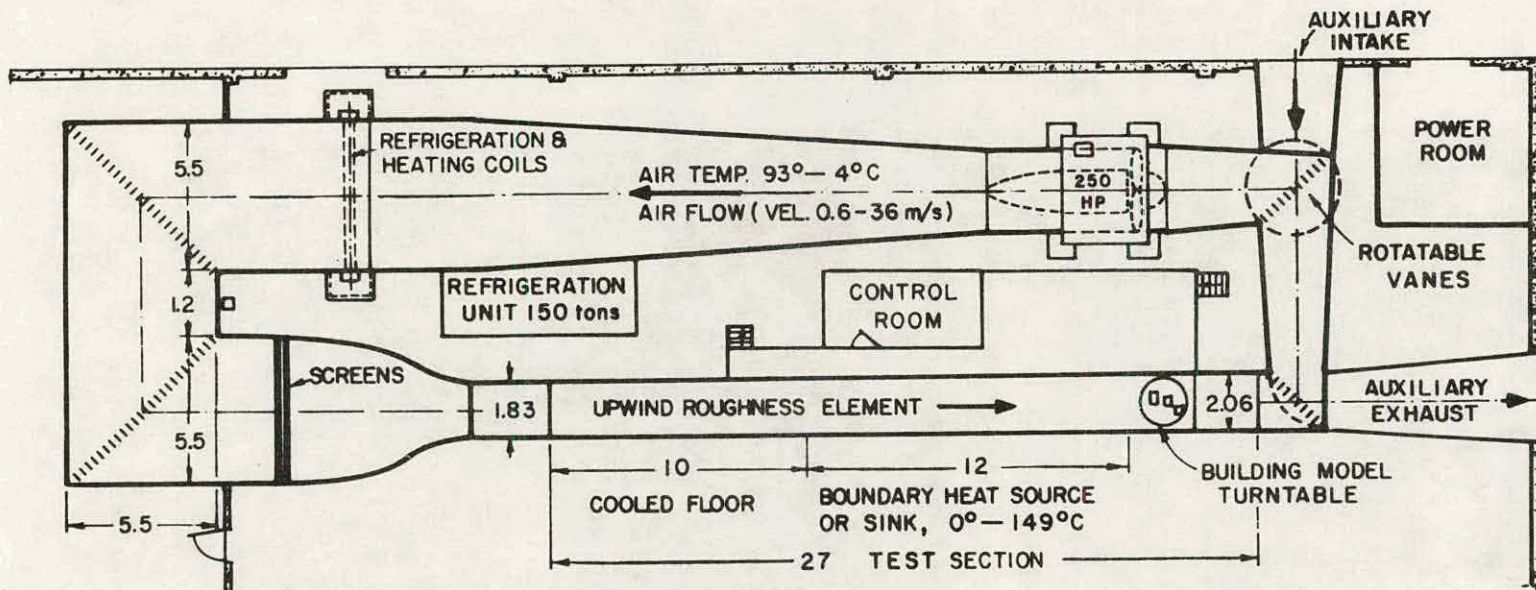

PLAN

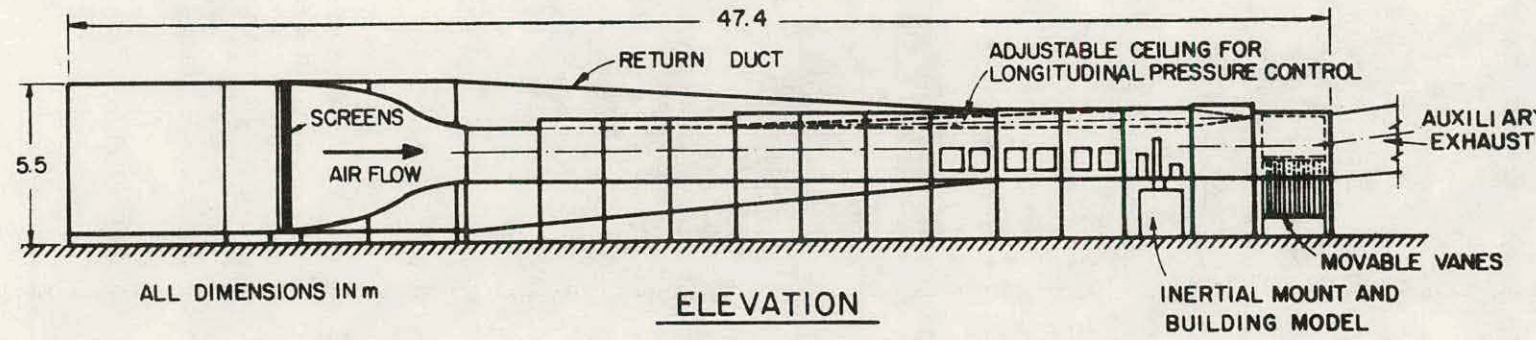

ELEVATION

ALL DIMENSIONS IN m

Figure 1. Meteorological Wind Tunnel

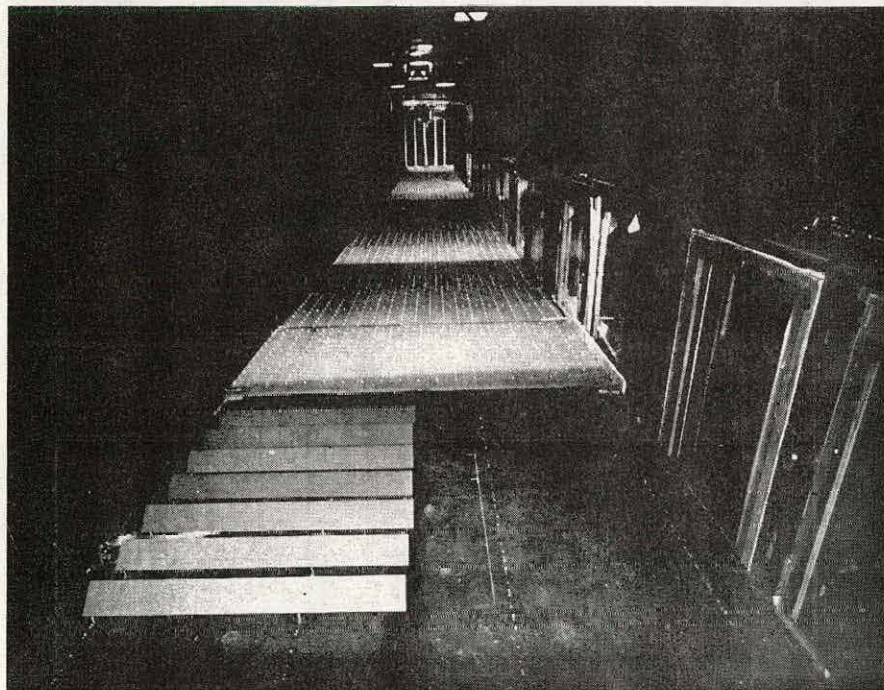
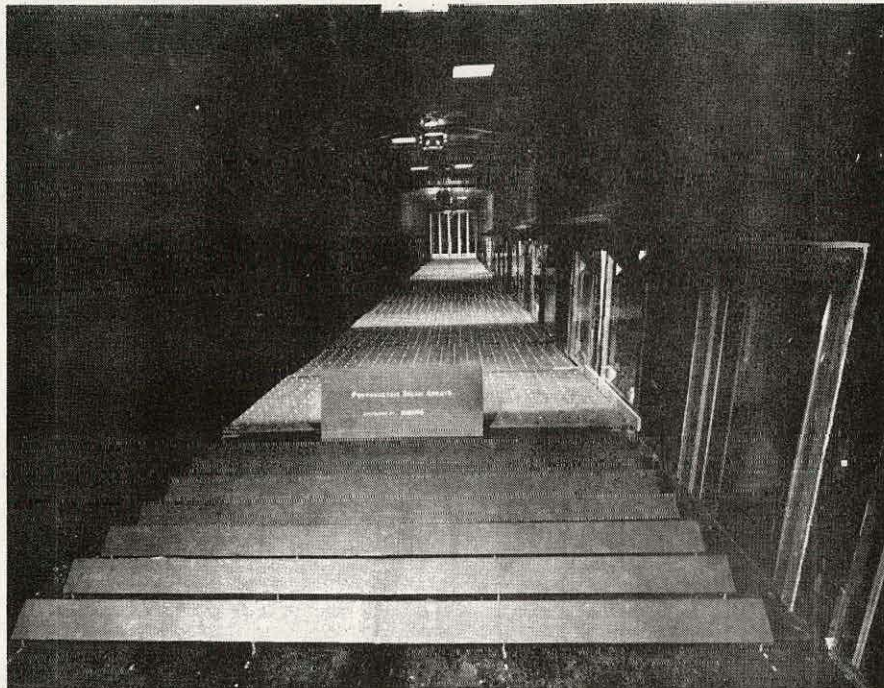

Figure 2. Array Field Models in Meteorological Wind Tunnel

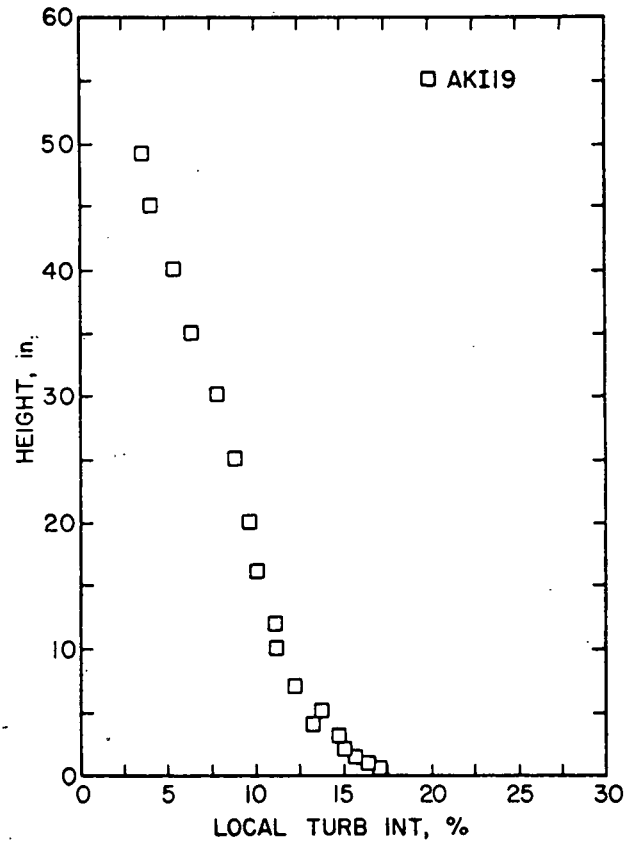
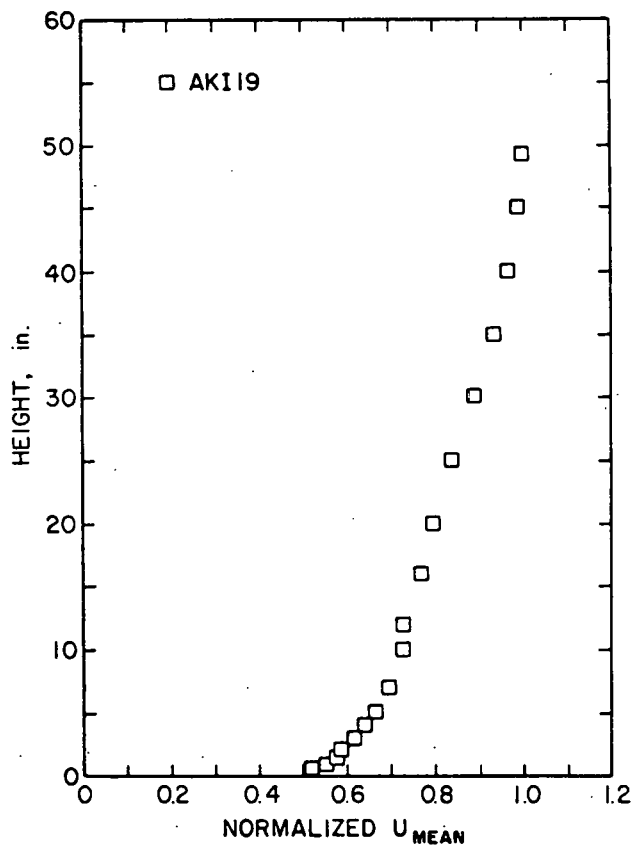

Figure 3. Mean Velocity and Turbulence Distribution in Nonuniform Flow

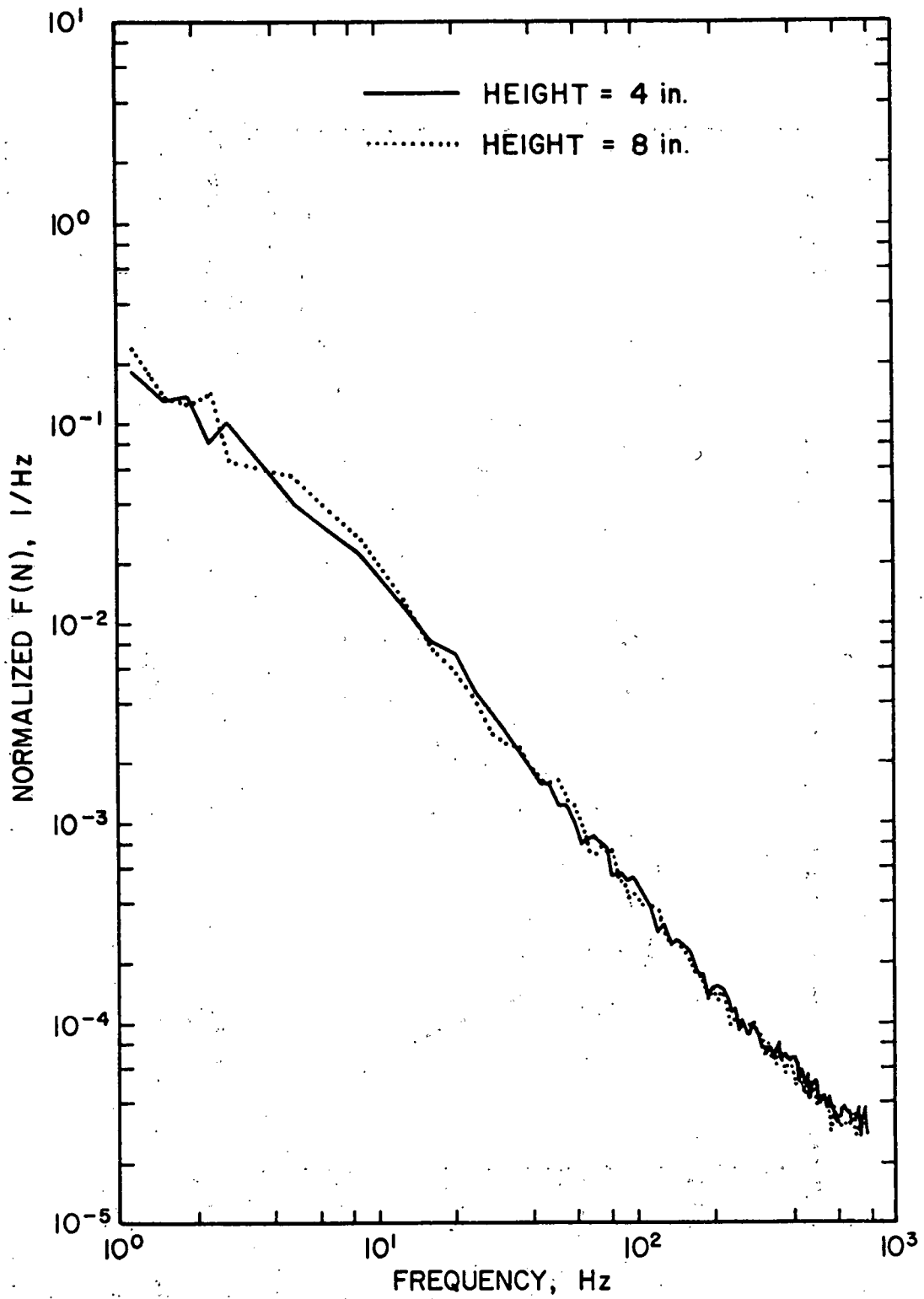

Figure 4. One Dimensional Velocity Spectra in Nonuniform Flow

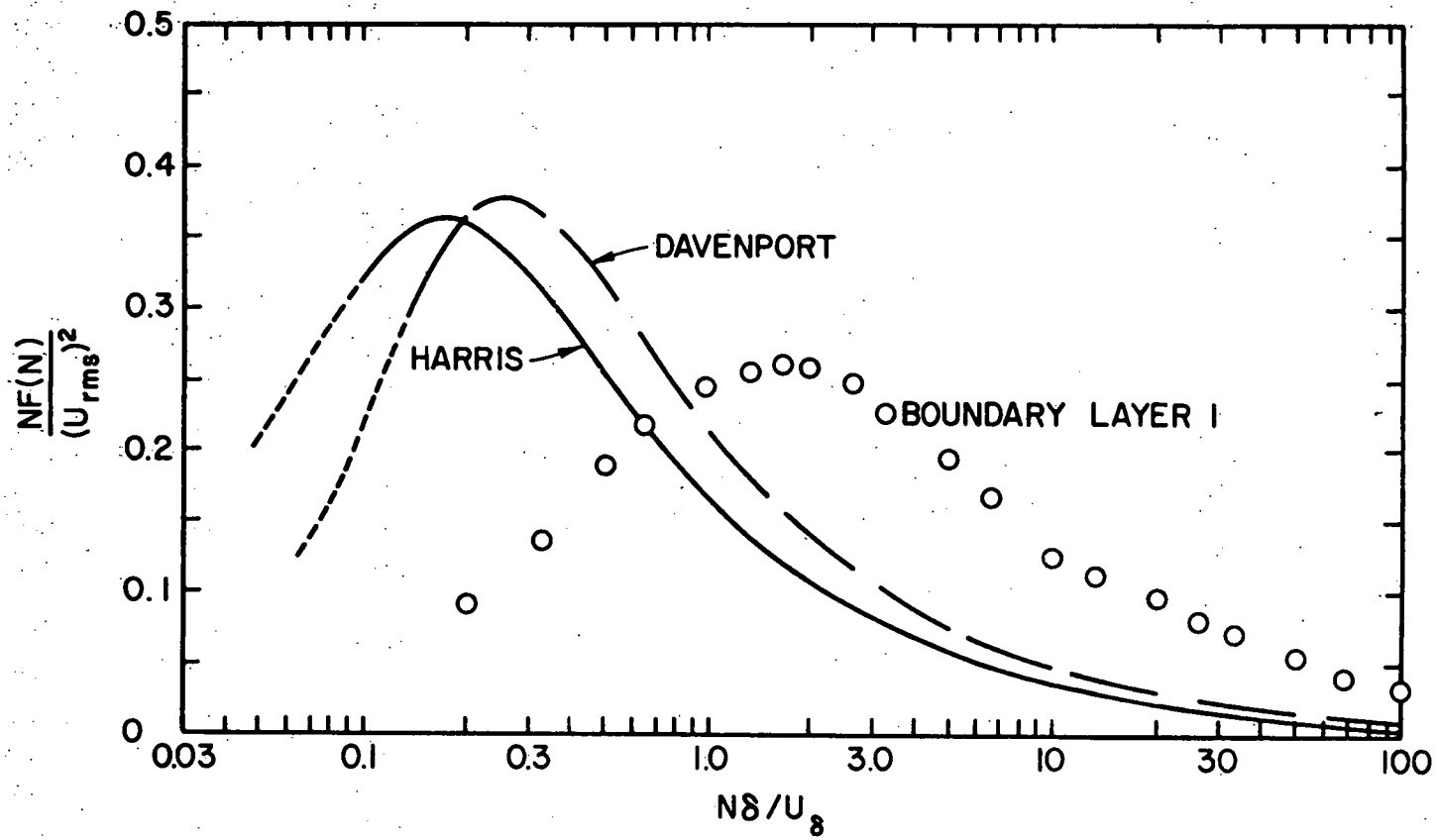

Figure 5. Turbulence Spectra in Nonuniform Flow (BL1) Compared to Atmospheric Spectra

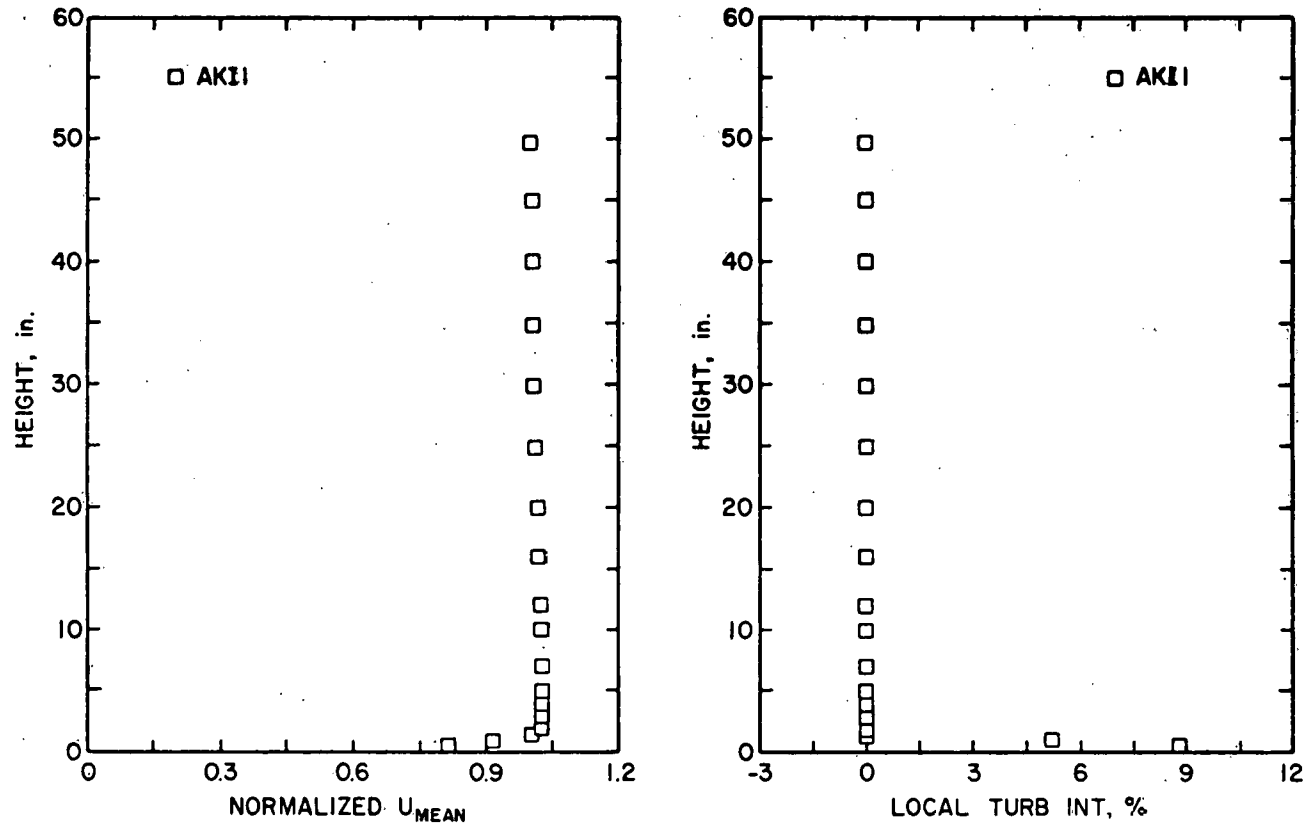

Figure 6. Mean Velocity and Turbulence Distribution in Uniform Flow

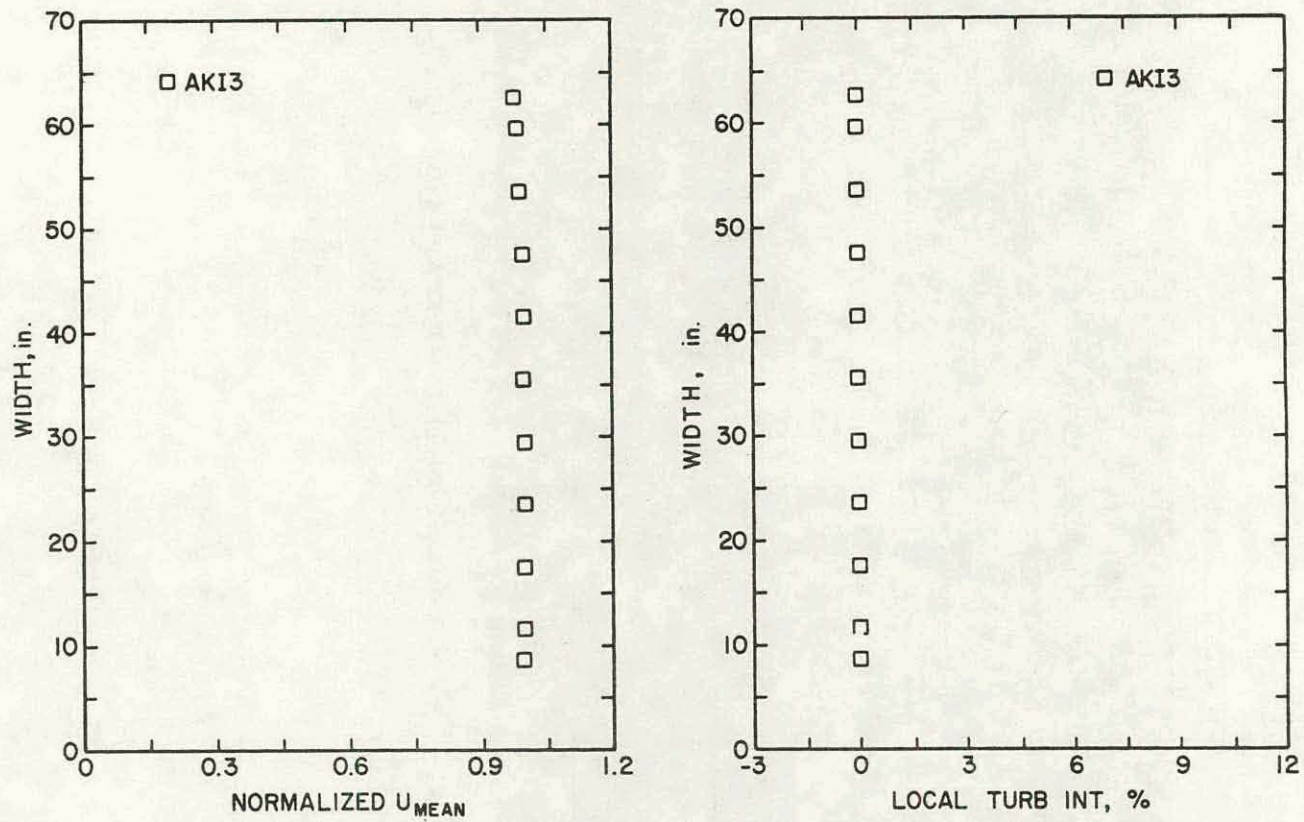

Figure 7. Typical Horizontal Velocity Distribution across Meteorological Wind Tunnel

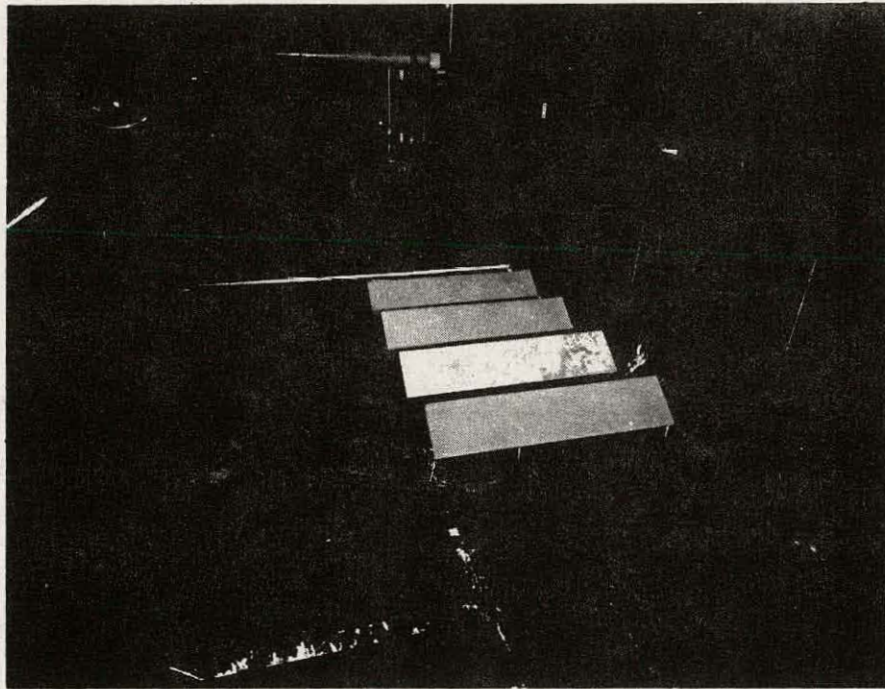

Figure 8. 1:12 Scale Models in Meteorological Wind Tunnel

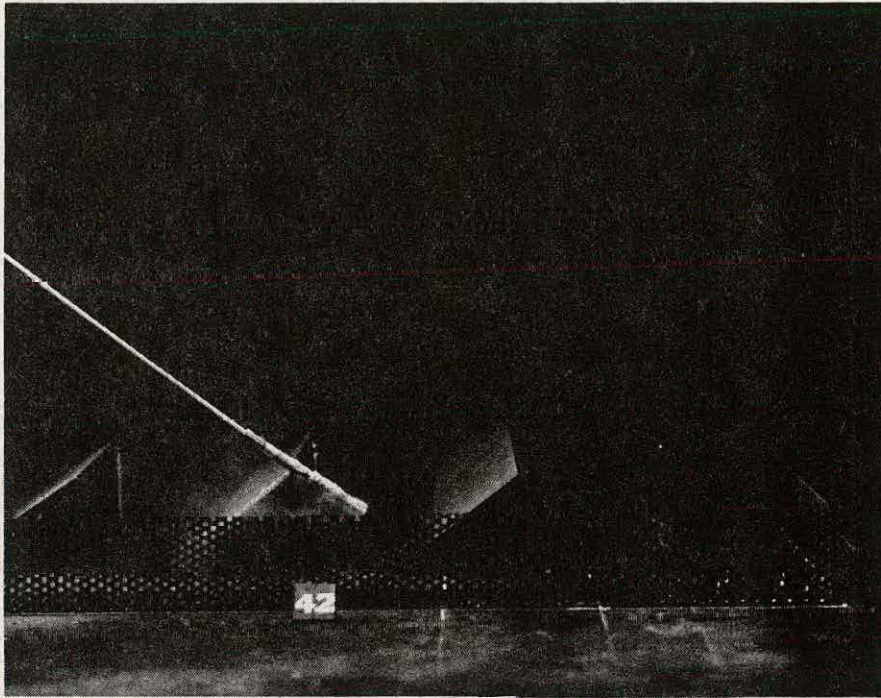
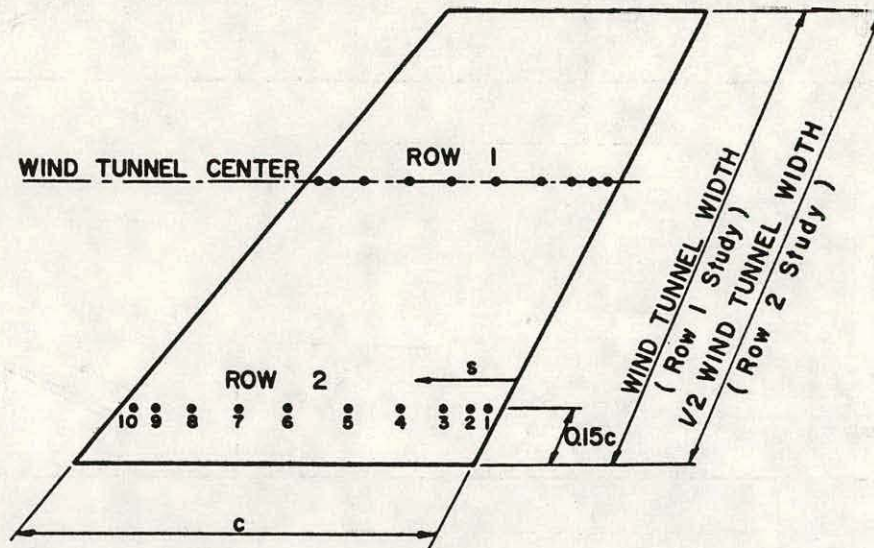

Figure 9. Photograph of Standard Corner Fence



TAP LOCATIONS - FRACTION OF CHORD s/c

	1	2	3	4	5	6	7	8	9	10
UPSTREAM SURFACE	0.052	0.102	0.172	0.272	0.432	0.592	0.752	0.852	0.922	0.972
DOWNSTREAM SURFACE	0.028	0.078	0.148	0.248	0.408	0.568	0.728	0.828	0.898	0.948

Figure 10. Position of Pressure Taps on Instrumented Model

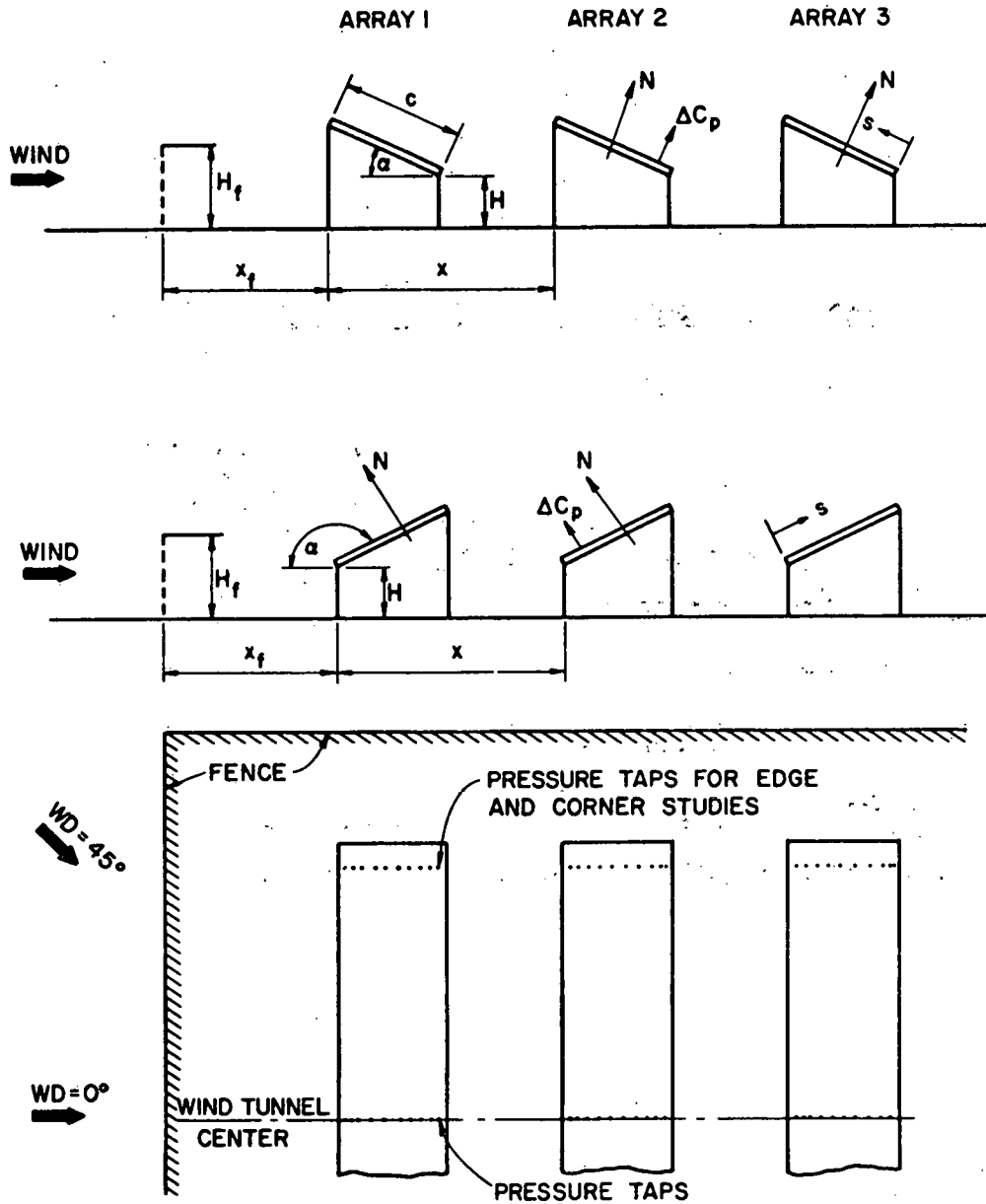

Figure 11. Schematic Description of Array Field

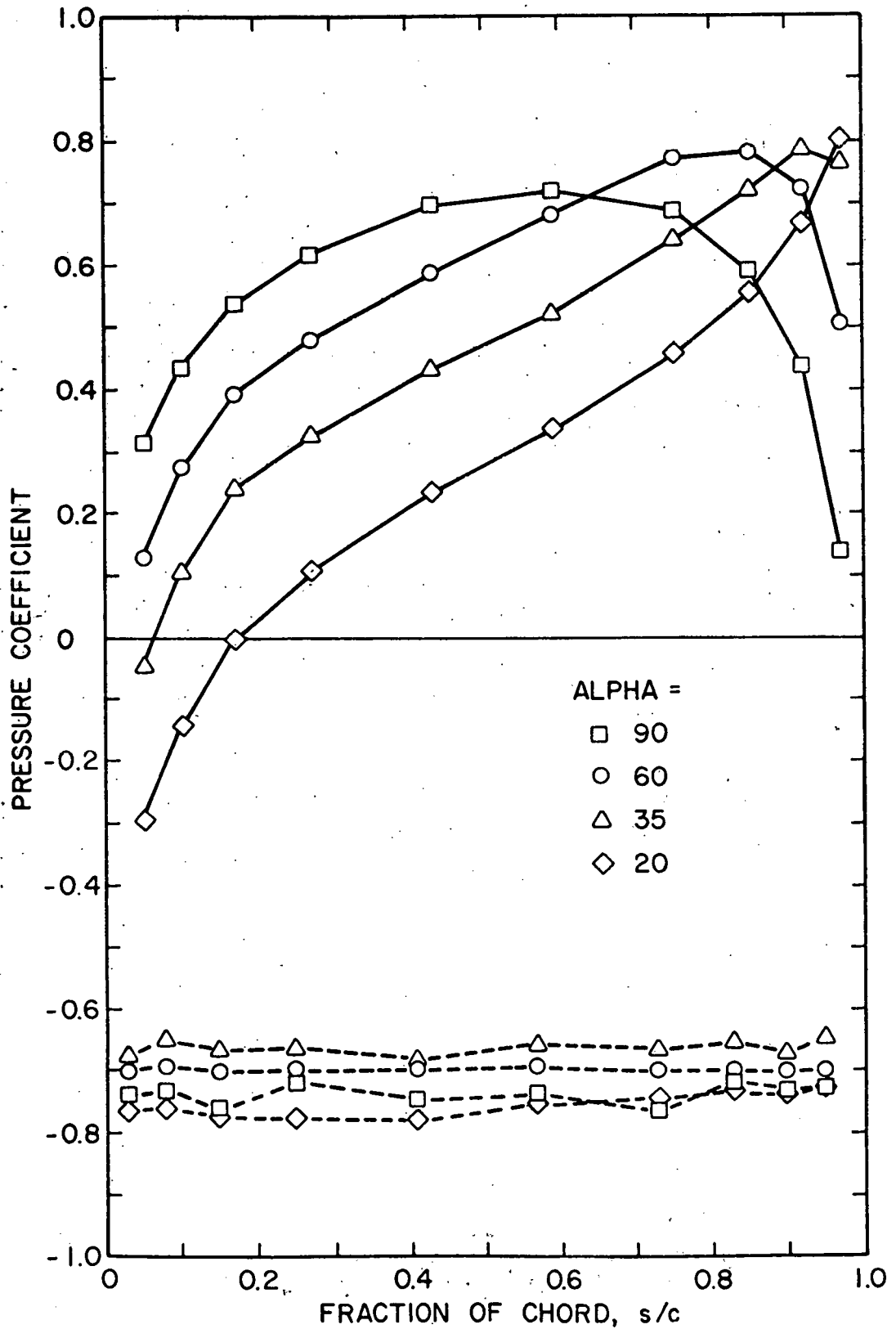

Figure 12. Front and Back Pressures on a Single Array in Uniform Flow, $WD = 0^\circ$, $H/c = 0.25$, $\alpha = 20^\circ, 35^\circ, 60^\circ$ and 90°

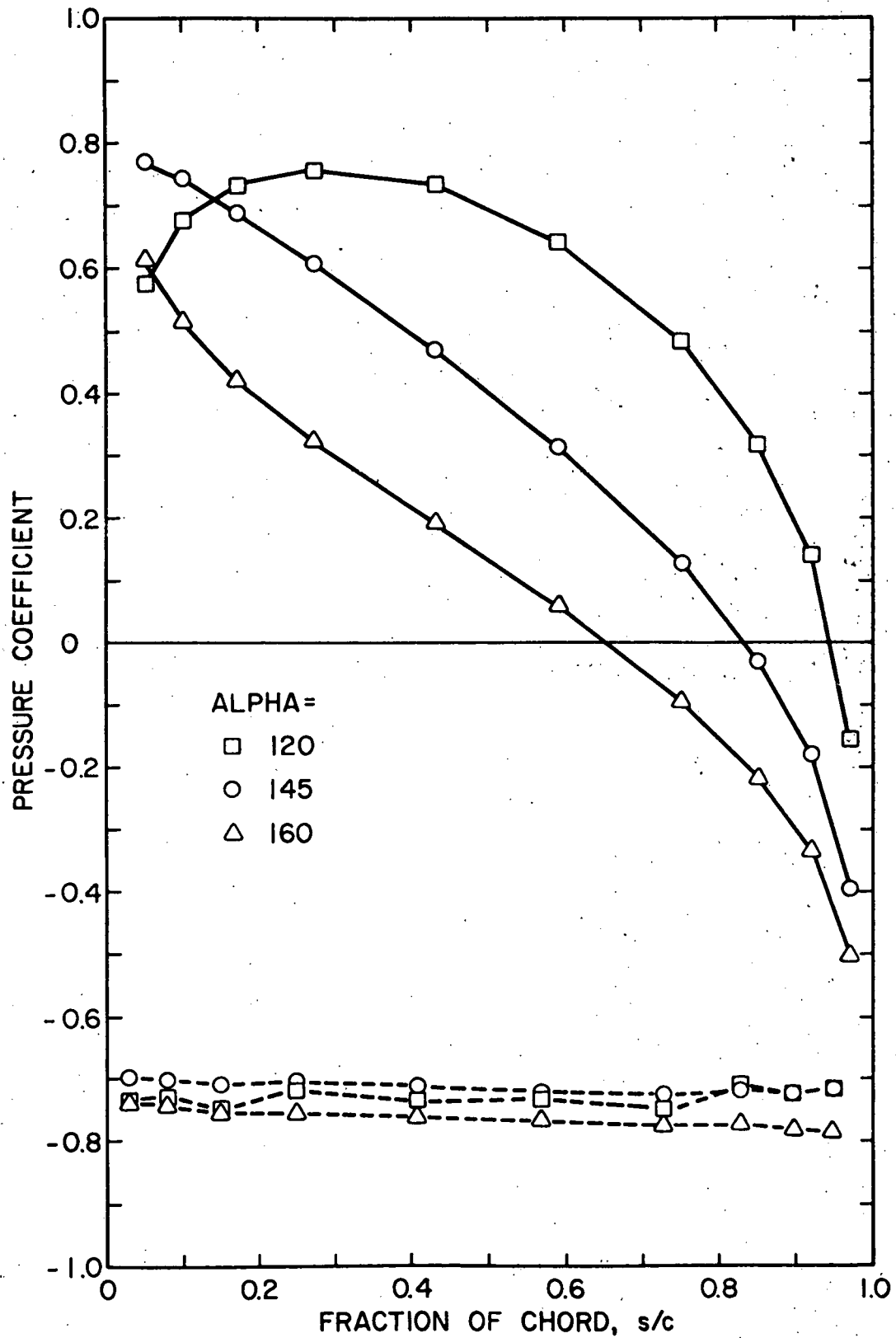

Figure 13. Front and Back Pressures on a Single Array in Uniform Flow, $WD = 0^\circ$, $H/c = 0.25$, $\alpha = 120^\circ$, 145° and 160°

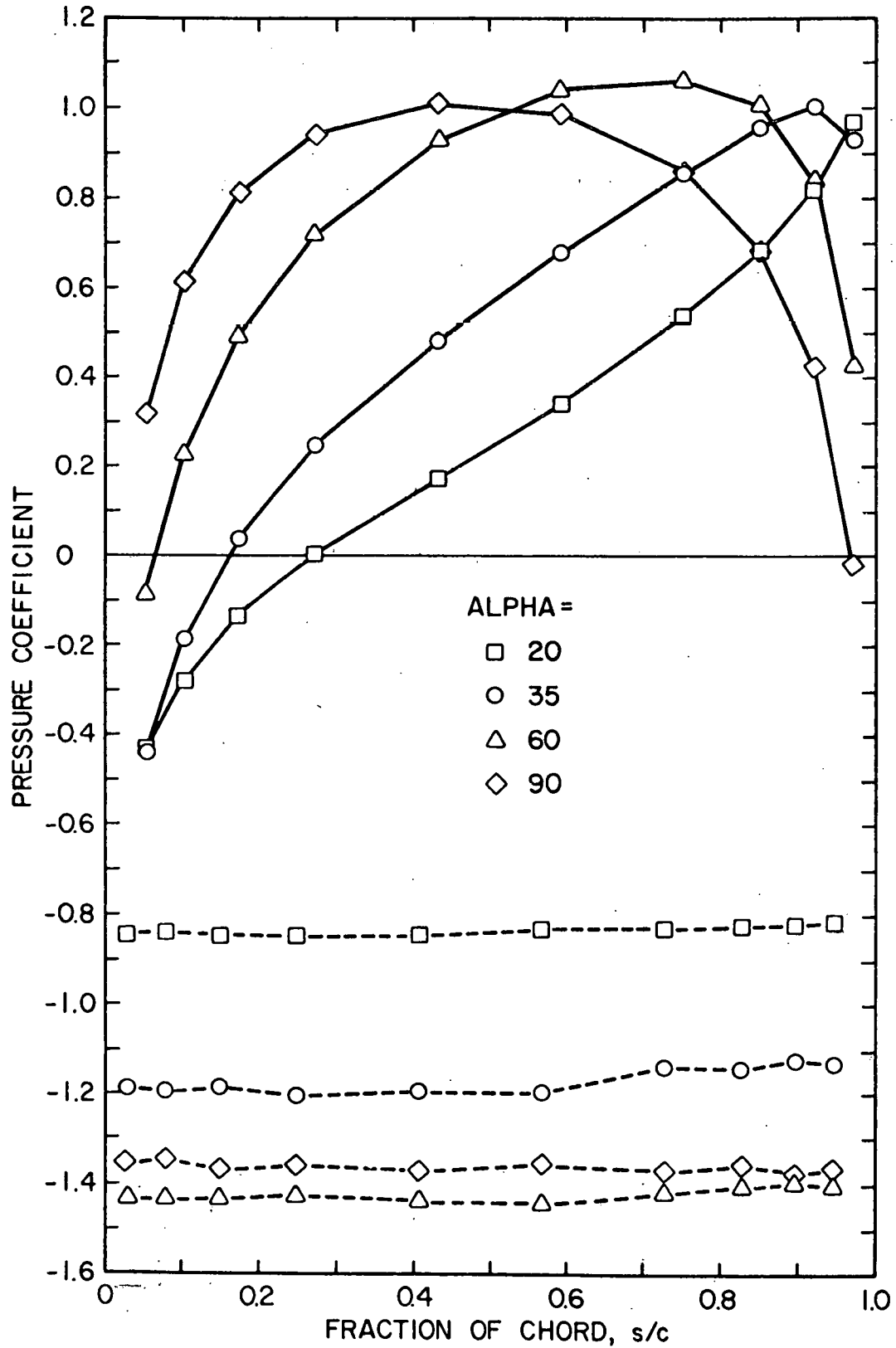

Figure 14. Front and Back Pressures on a Single Array in Uniform Flow, $WD = 0^\circ$, $H/c = \text{infinity}$, $\alpha = 20^\circ, 30^\circ, 60^\circ$, and 90°

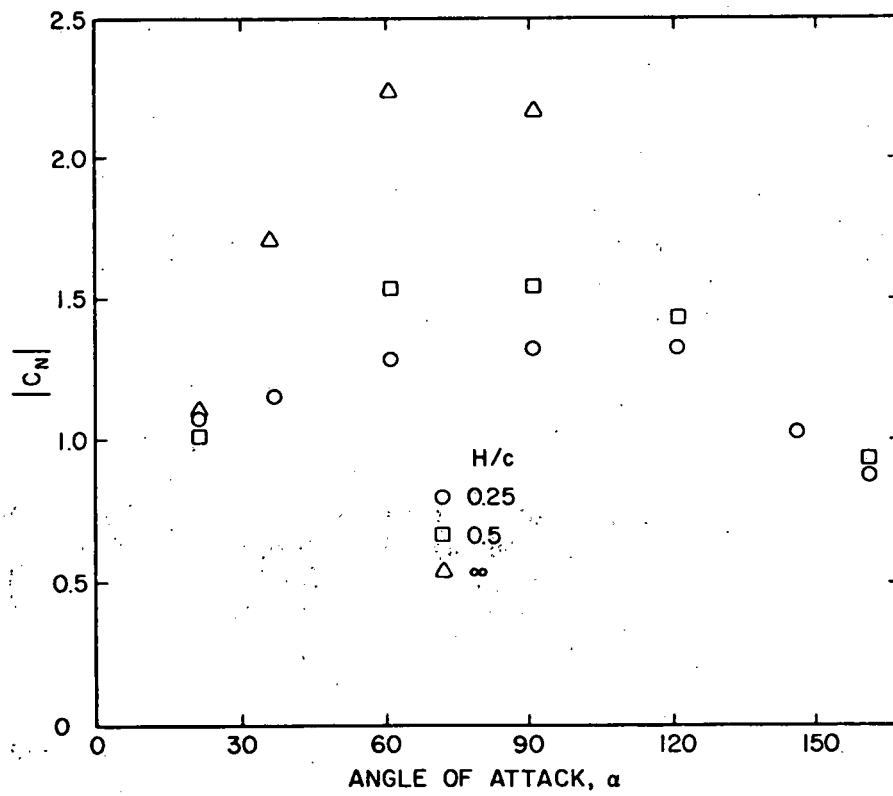

Figure 15. Absolute Values of Normal Force Coefficients on a Single Array in Uniform Flow, $WD = 0^\circ$

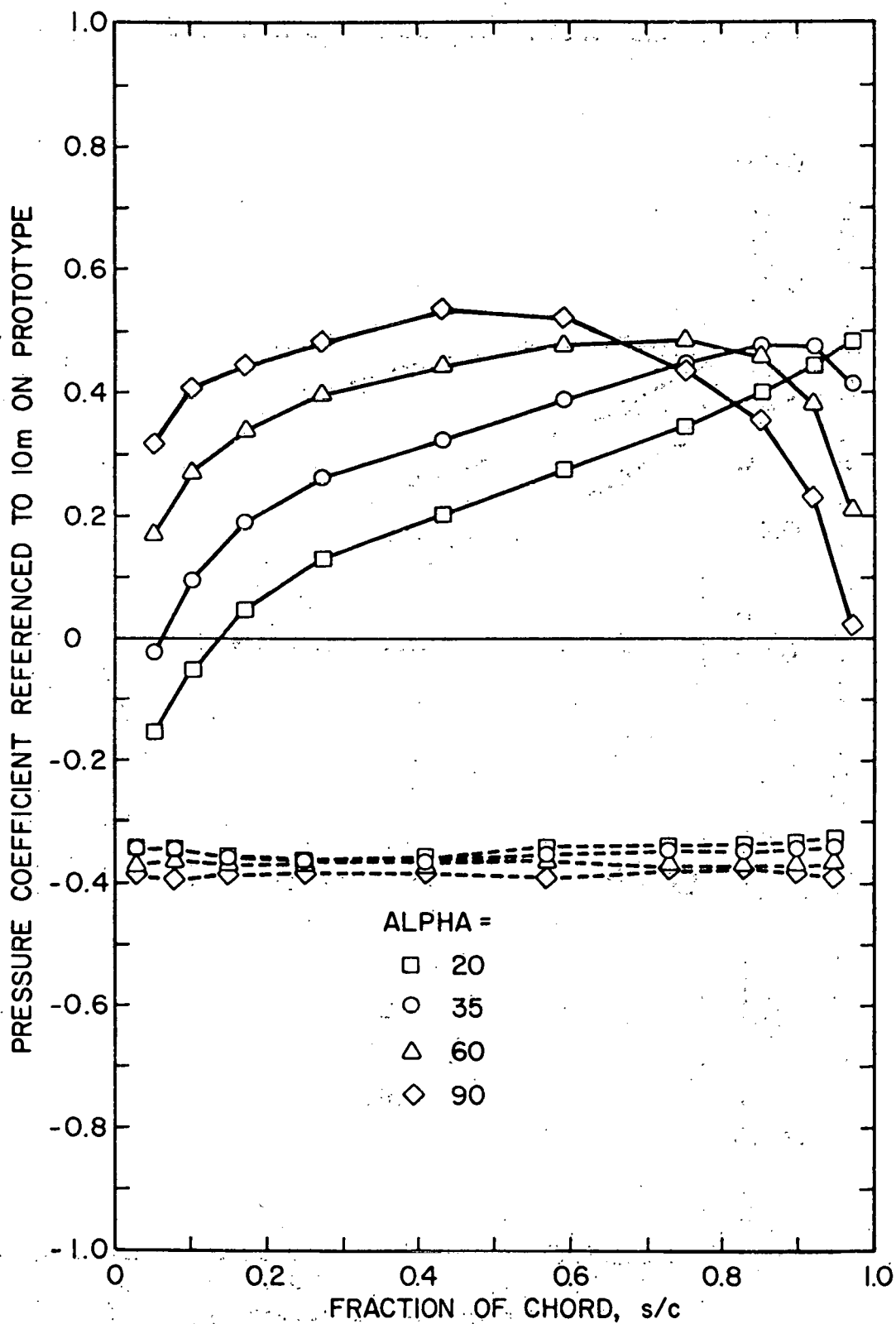

Figure 16. Front and Back Pressures on a Single Array in Nonuniform Flow, $WD = 0^\circ$; $H/c = 0.25$, $\alpha = 20^\circ$, 30° , 60° and 90°

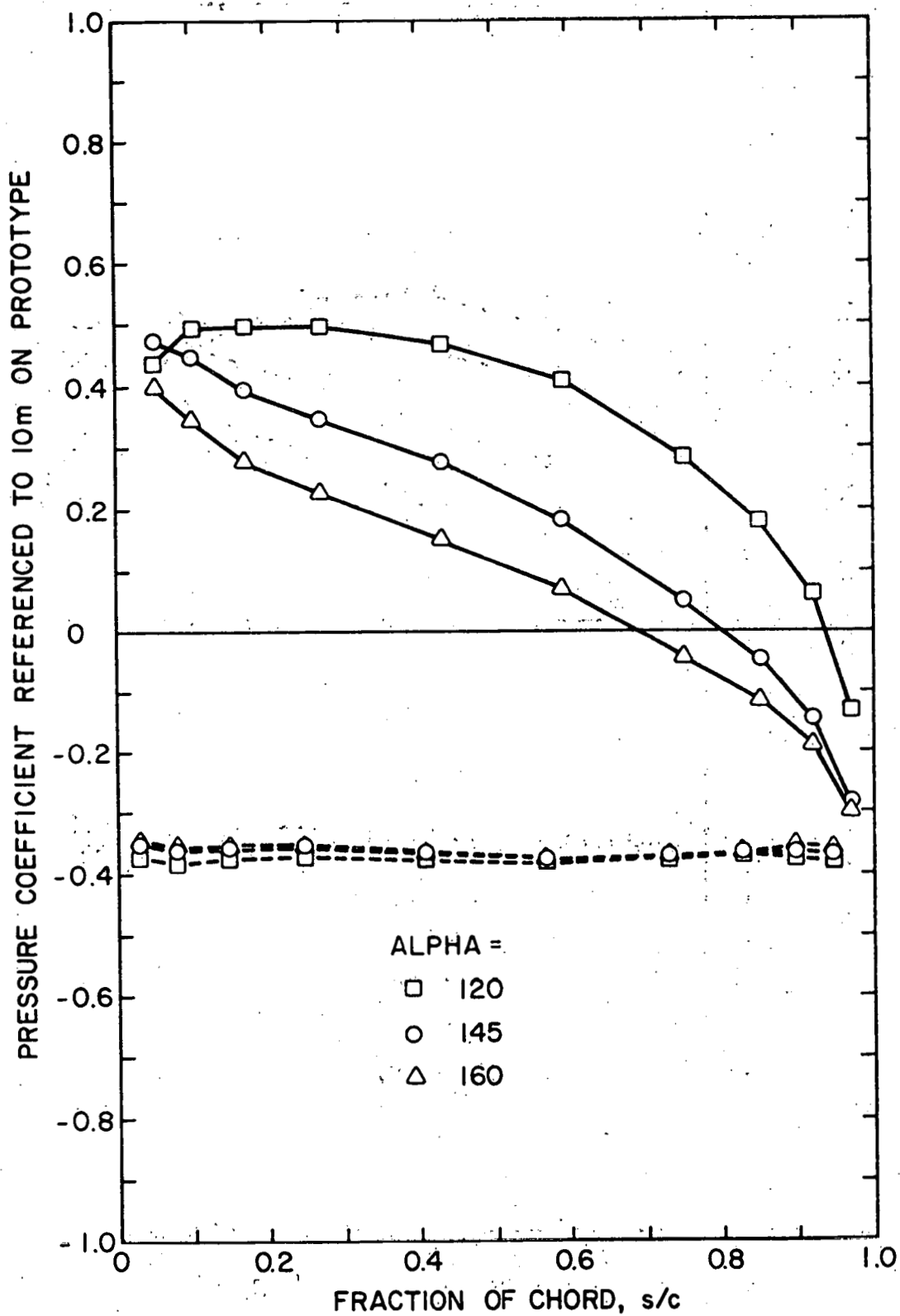

Figure 17. Front and Back Pressures on a Single Array in Nonuniform Flow, $WD = 0^\circ$, $H/c = 0.25$, $\alpha = 120^\circ$, 145° and 160°

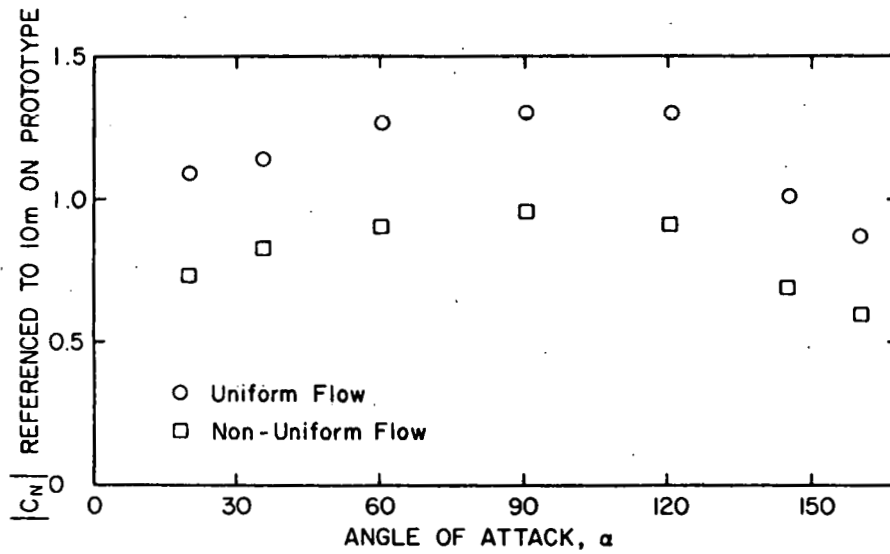

Figure 18. Absolute Values of Normal Force Coefficients on a Single Array in Nonuniform and Uniform Flows, $WD = 0^\circ$, $H/c = 0.25$

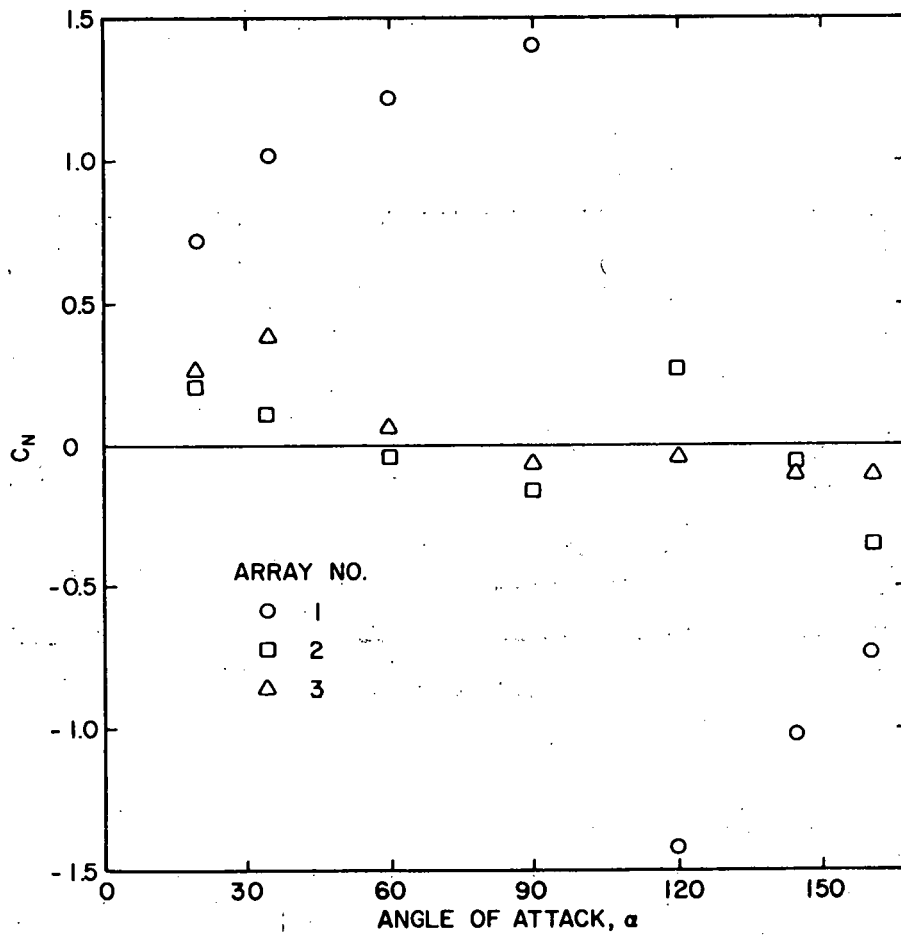

Figure 19. Normal Force Coefficients for an Array Field in Uniform Flow, $WD = 0^\circ$, $x/c = 2.0$, $H/c = 0.25$, No Fence

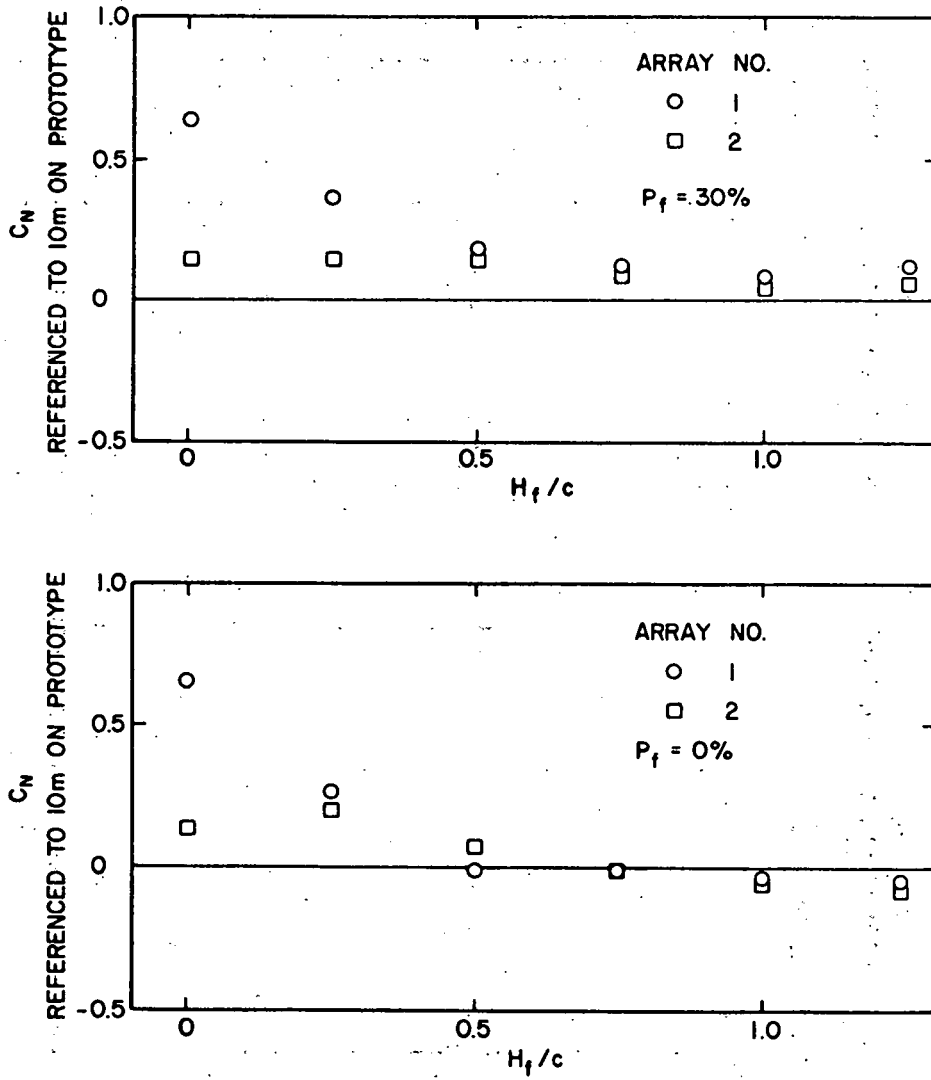

Figure 20. Normal Force Coefficients for an Array Field with a Fence of Various Height and Porosity, $WD = 0^\circ$, $x/c = 2.0$, $H/c = 0.25$, $\alpha = 35^\circ$

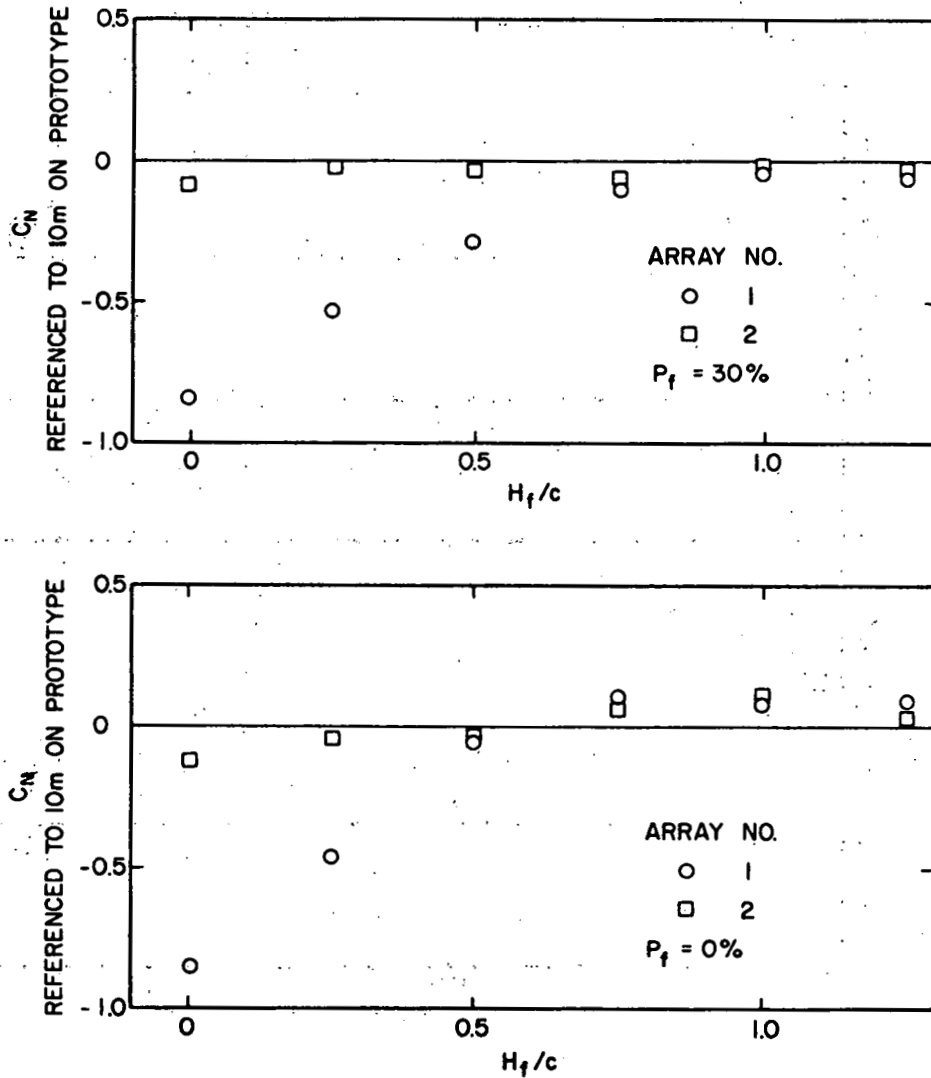

Figure 21. Normal Force Coefficients for an Array Field with a Fence of various Height and Porosity, $WD = 0^\circ$, $x/c = 2.0$, $H/c = 0.25$, $\alpha = 145^\circ$

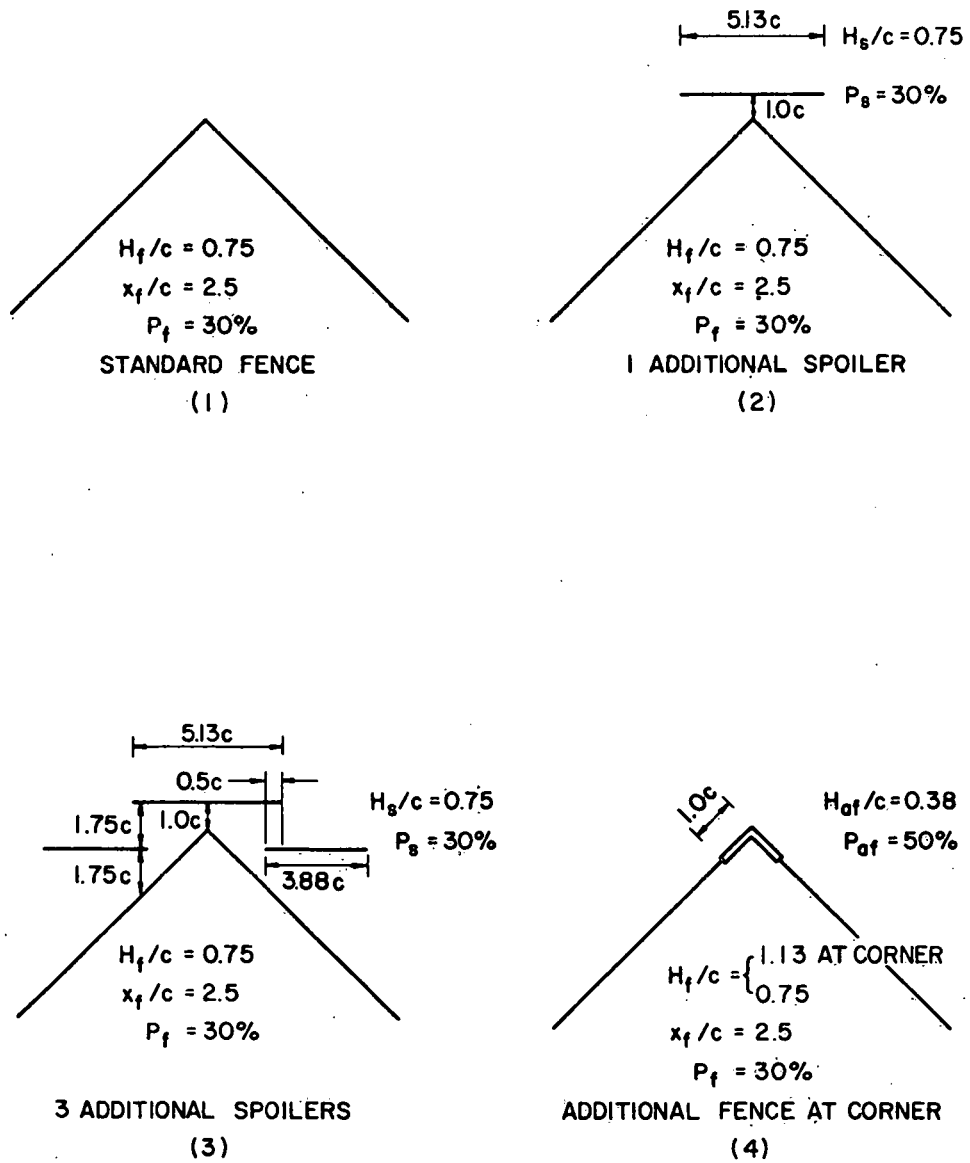

Figure 22. Corner Fence Configurations

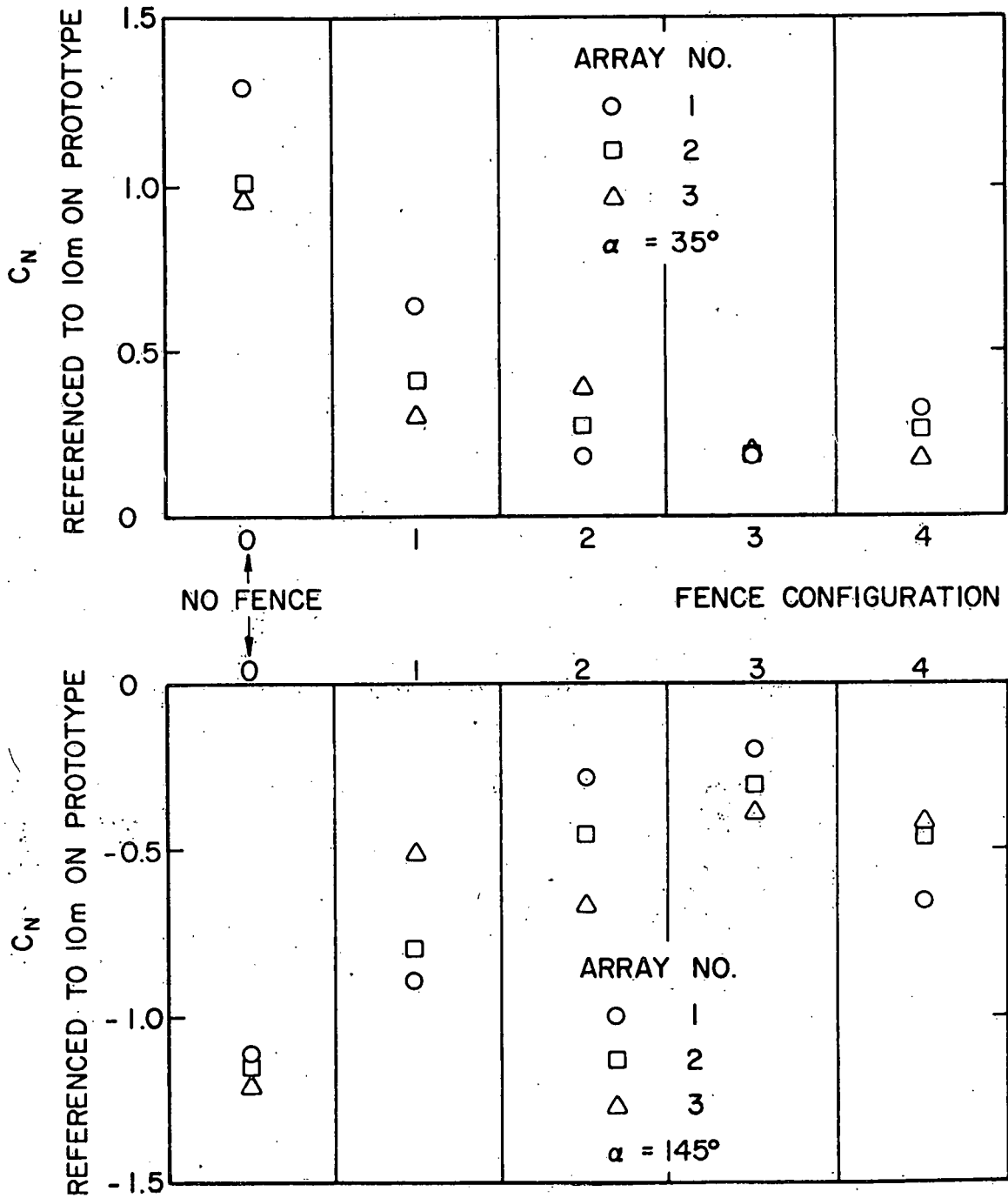

Figure 23. Normal Force Coefficients for an Array Field with Various Fence Configurations; $WD = 45^\circ$, $x/c = 2.0$, $H/c = 0.25$, $MC = 0$

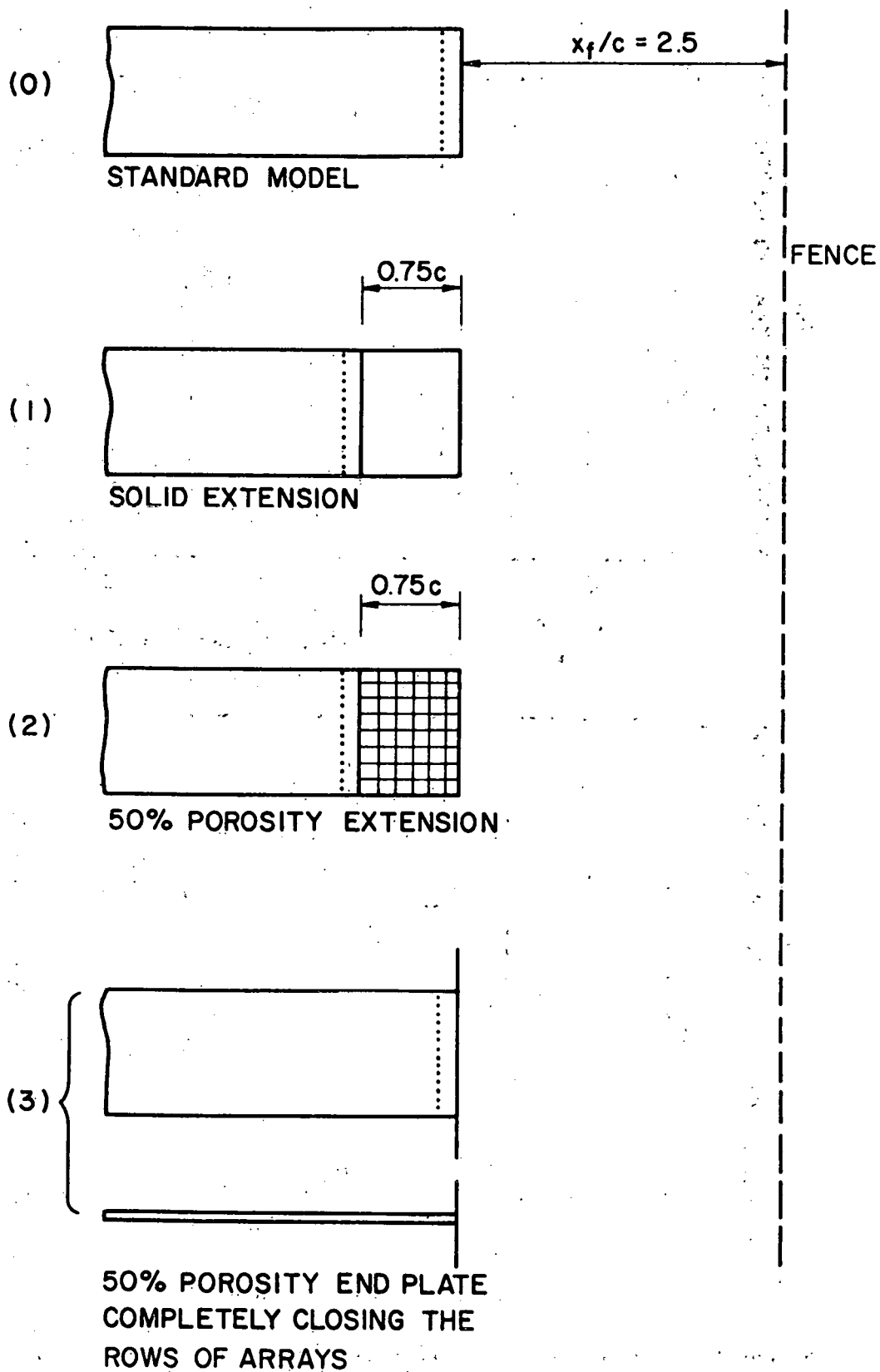

Figure 24. Model Configurations

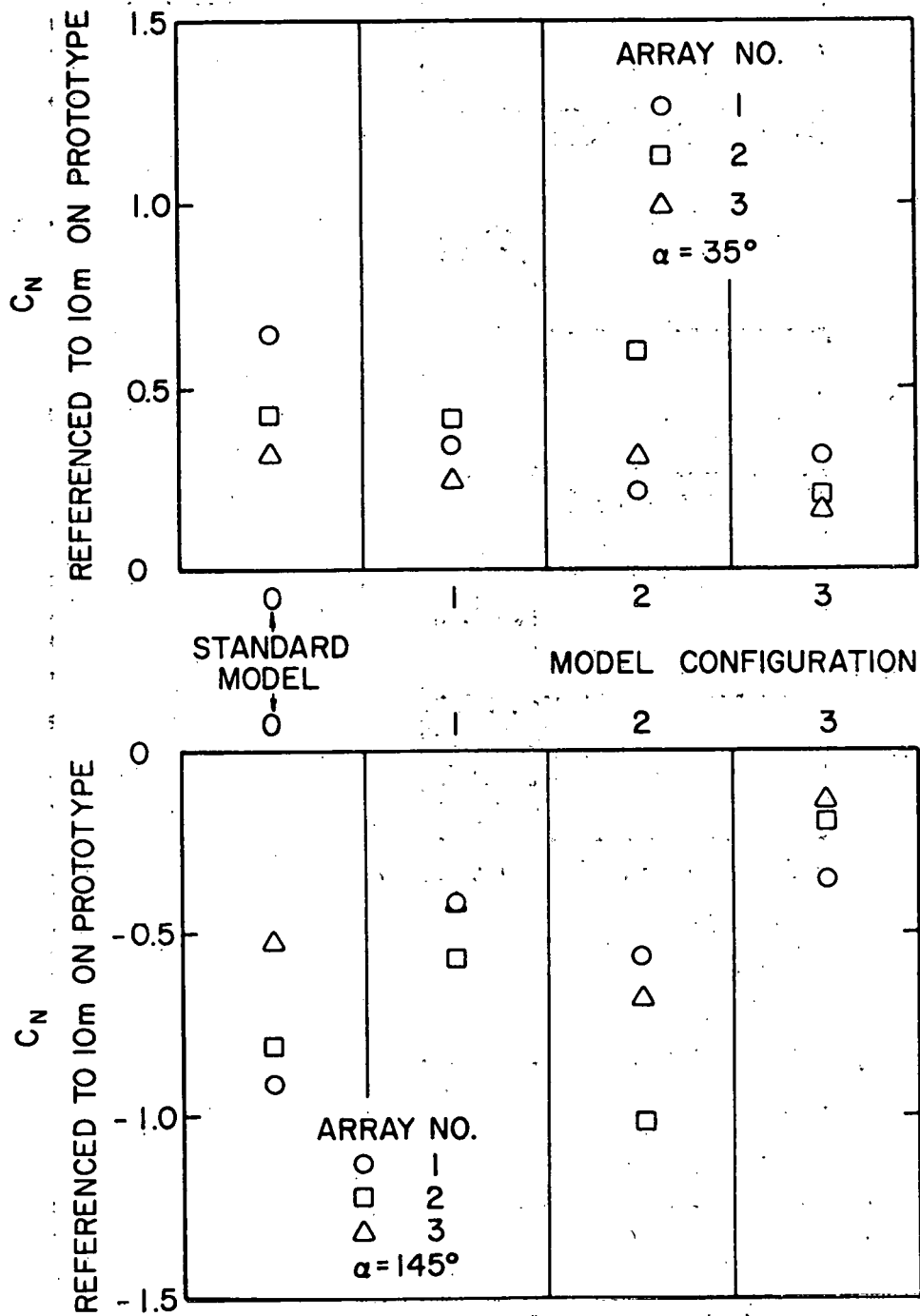

Figure 25. Normal Force Coefficients for an Array Field with Various Model Configurations, $WD = 45^\circ$, $x/c = 2.0$, $H/c = 0.25$, $FC = 1$

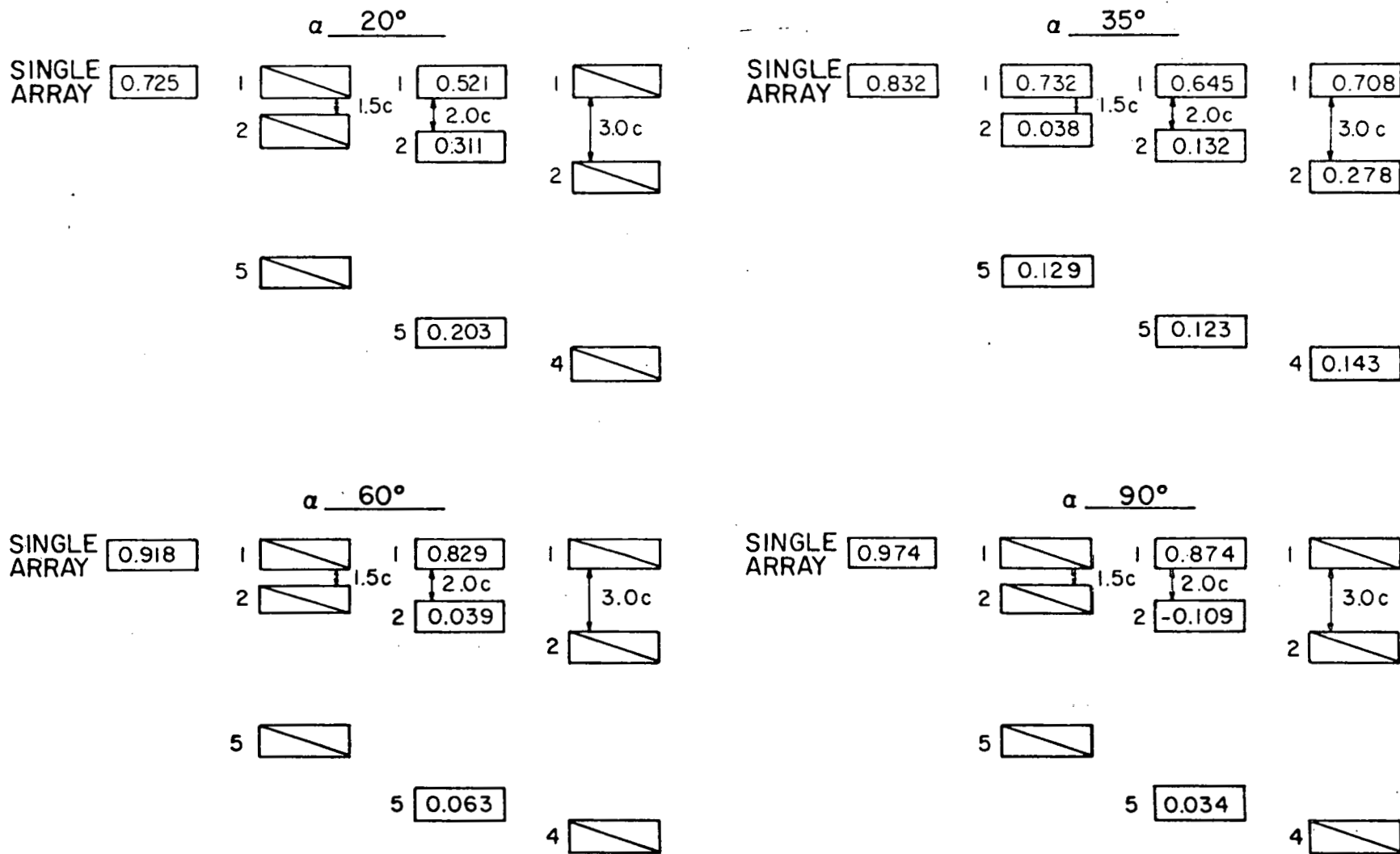

Figure 26. Normal Force Coefficients for an Array Field in Nonuniform Flow, No Fence, $WD = 0^\circ$, $H/c = 0.25$, $\alpha = 20^\circ, 35^\circ, 60^\circ$ and 90°

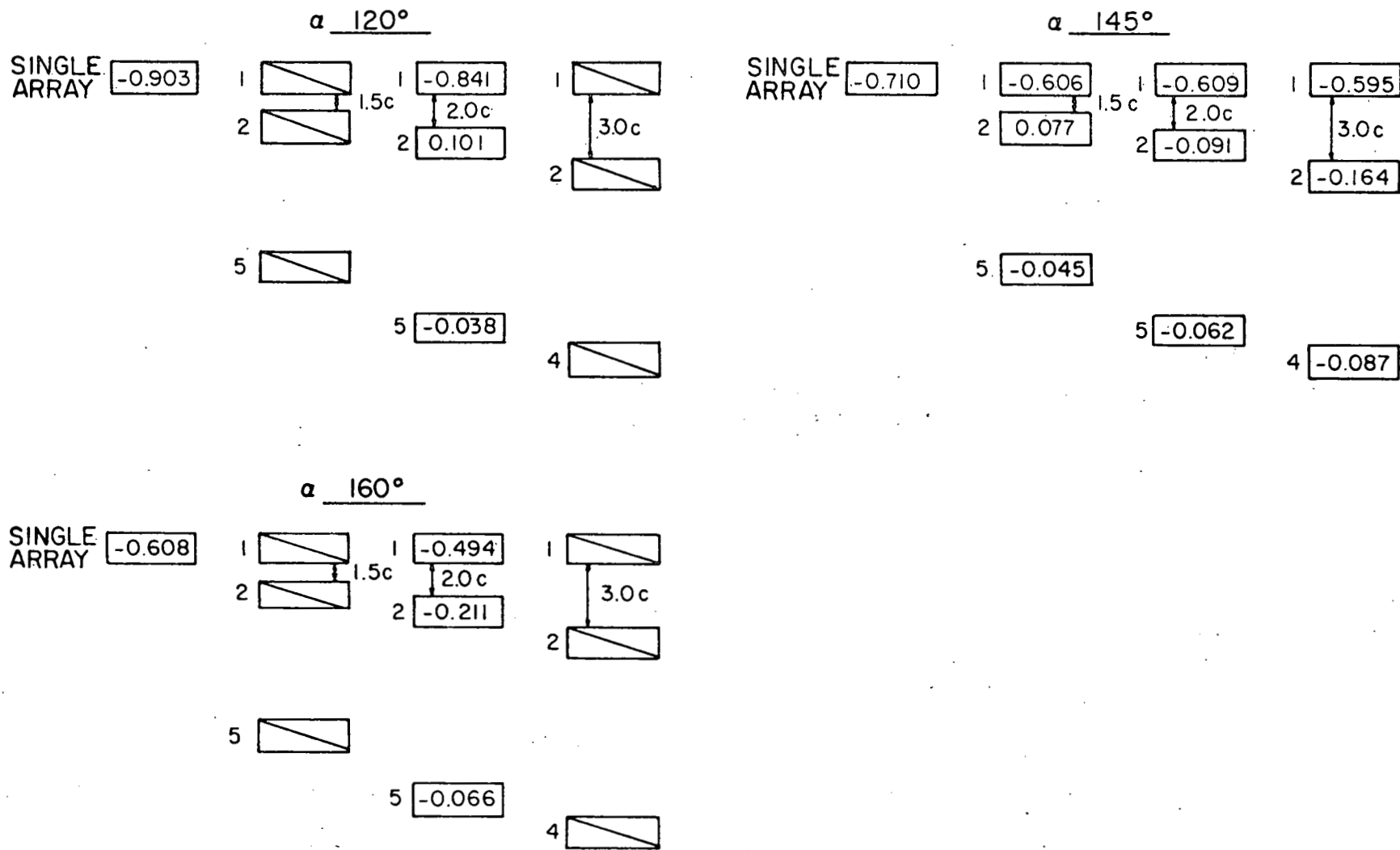

Figure 27. Normal Force Coefficients for an Array Field in Nonuniform Flow, No Fence, $WD = 0^\circ$, $H/c = 0.25$, $\alpha = 120^\circ$, 145° and 160°

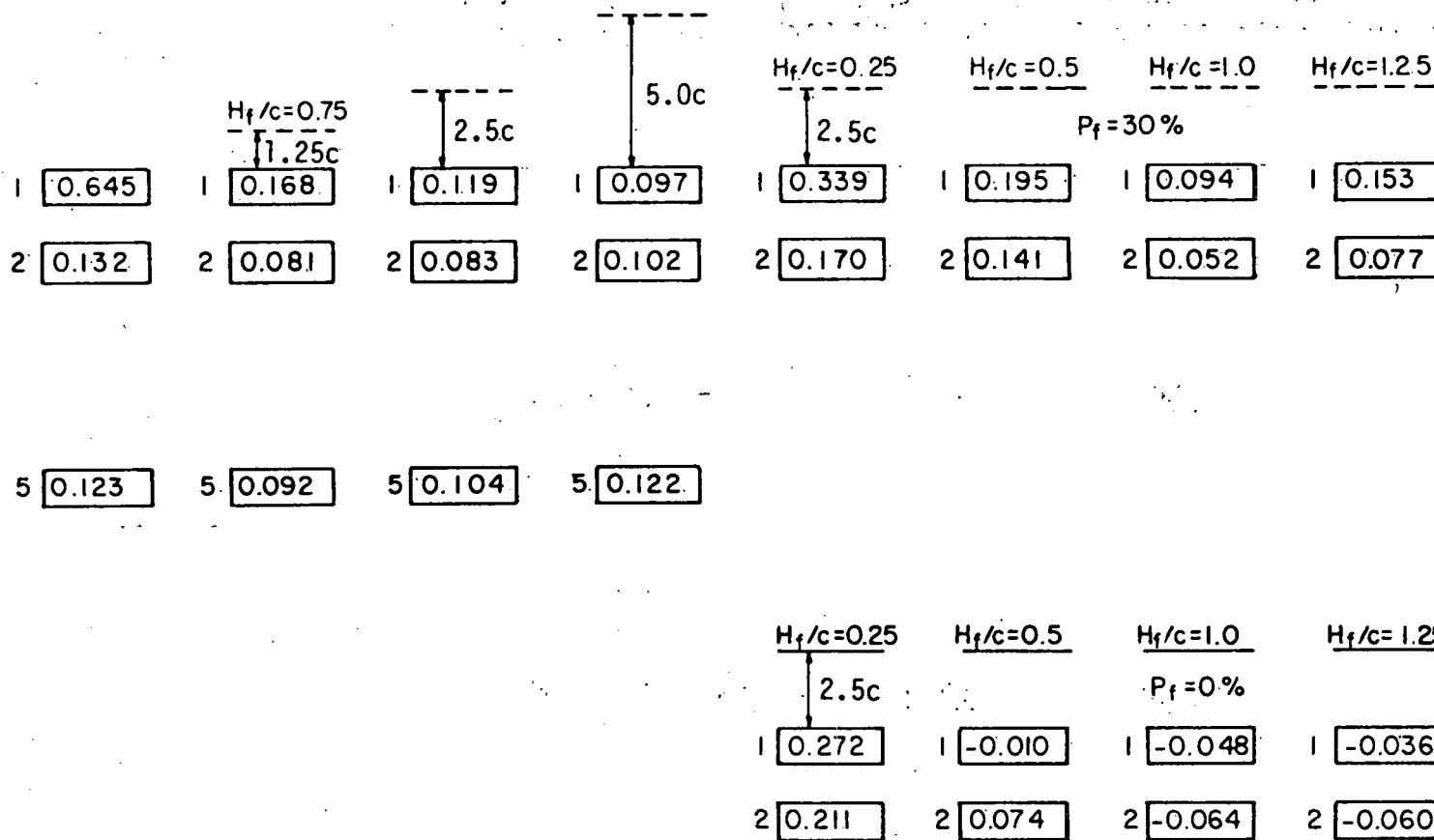

Figure 28a. Normal Force Coefficients for an Array Field with Various Fences, $WD = 0^\circ$, $x/c = 2.0$, $H/c = 0.25$, $\alpha = 35^\circ$, Nonuniform Flow.

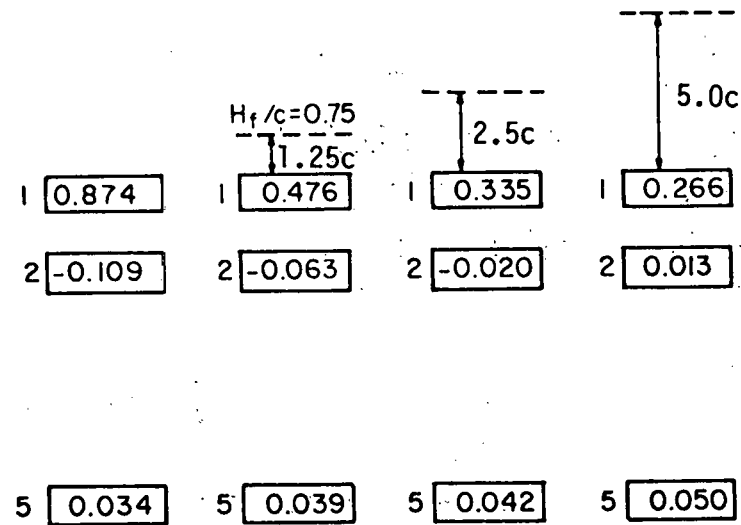

Figure 28b. Normal Force Coefficients for an Array Field with Various Fences,
 $WD = 0^\circ$, $x/c = 2.0$, $H/c = 0.25$, $\alpha = 90^\circ$, Nonuniform Flow

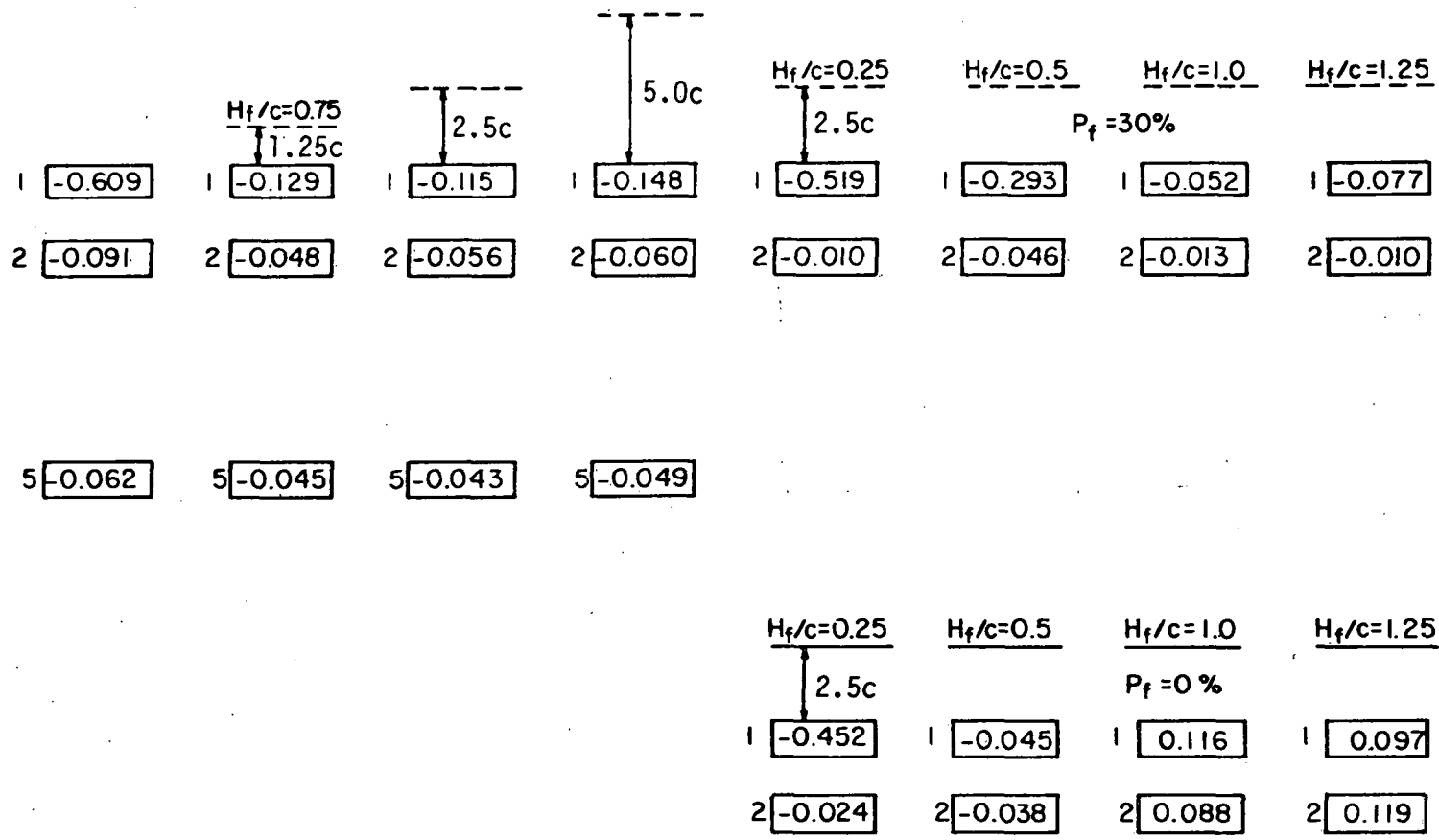

Figure 28c. Normal Force Coefficients for an Array Field with Various Fences, $WD = 0^\circ$, $x/c = 2.0$, $H/c = 0.25$, $\alpha = 145^\circ$, Nonuniform Flow

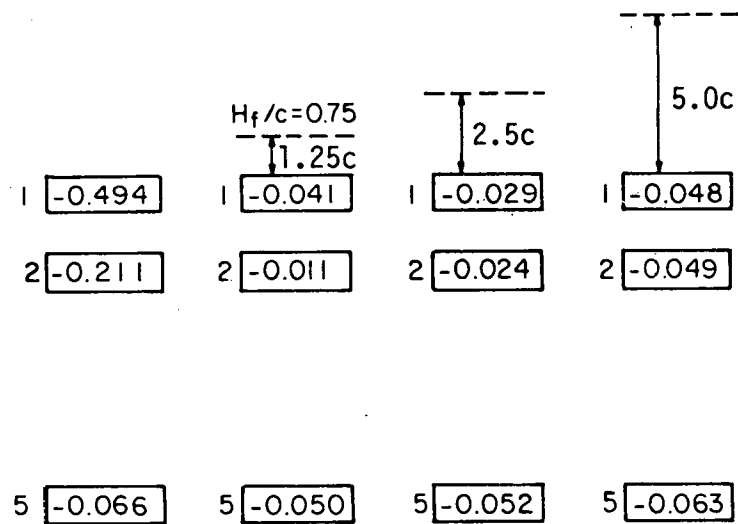

Figure 28d. Normal Force Coefficients for an Array Field with Various Fences,
 $WD = 0^\circ$, $x/c = 2.0$, $H/c = 0.25$, $\alpha = 160^\circ$, Nonuniform Flow

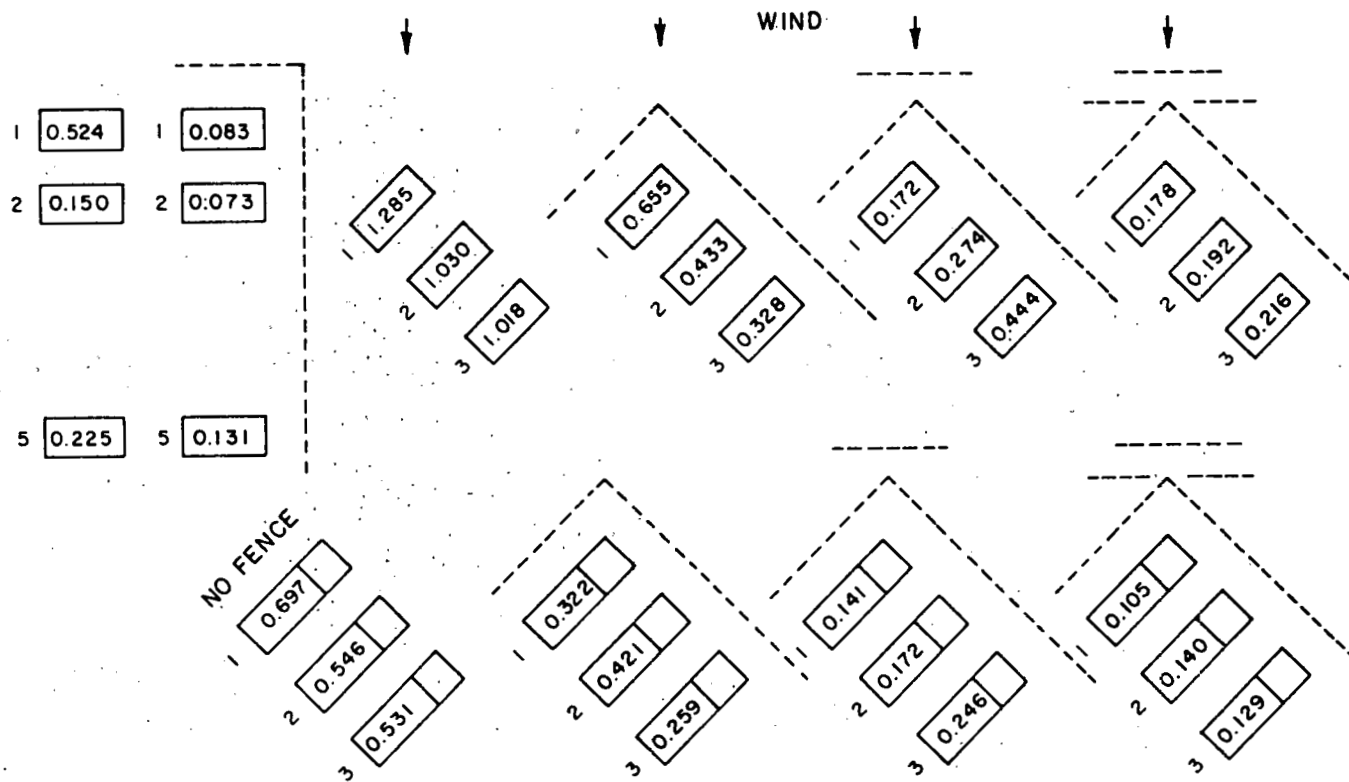

Figure 29a. Normal Force Coefficients for an Array Field, Edge and Corner Studies, $x/c = 2.0$, $H/c = 0.25$, $\alpha = 35^\circ$, Nonuniform Flow

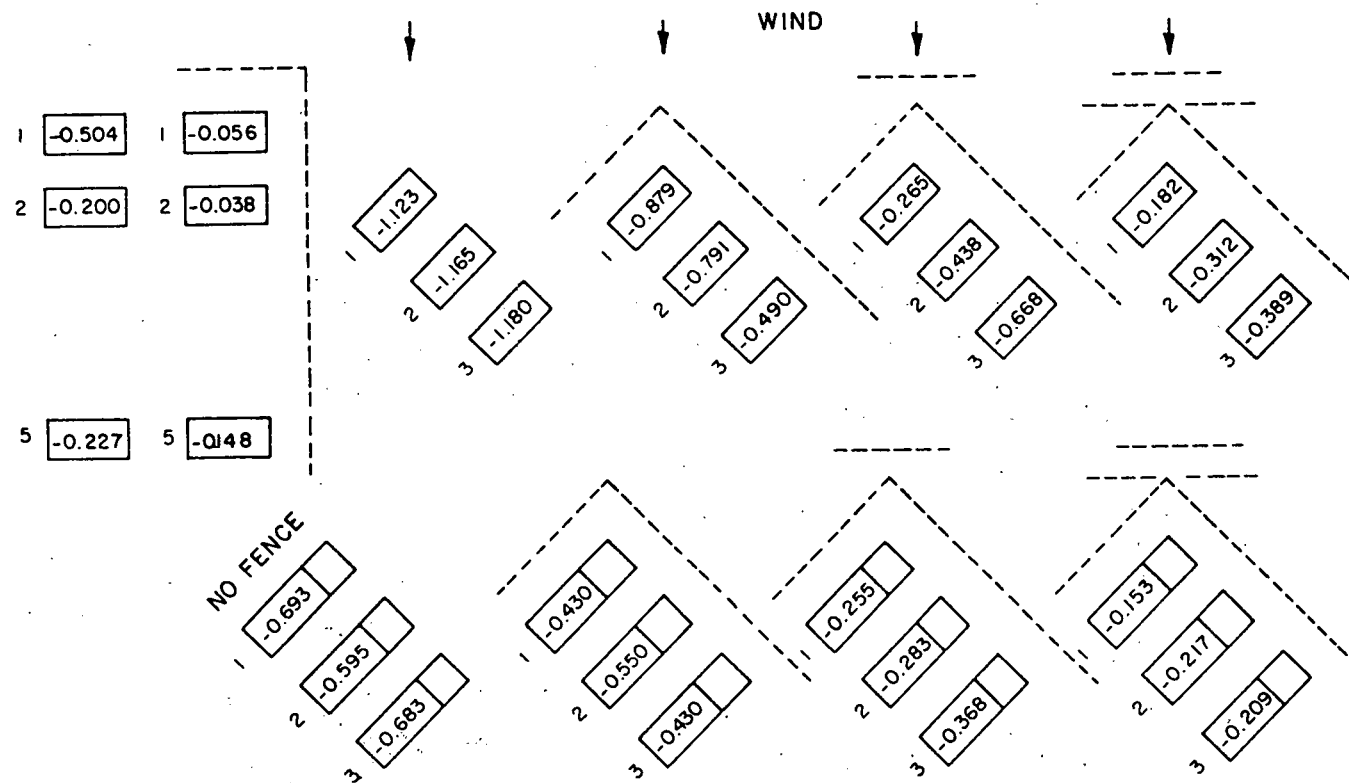

Figure 29b. Normal Force Coefficients for an Array Field, Edge and Corner Studies, $x/c = 2.0$, $H/c = 0.25$, $\alpha = 145^\circ$, Nonuniform Flow

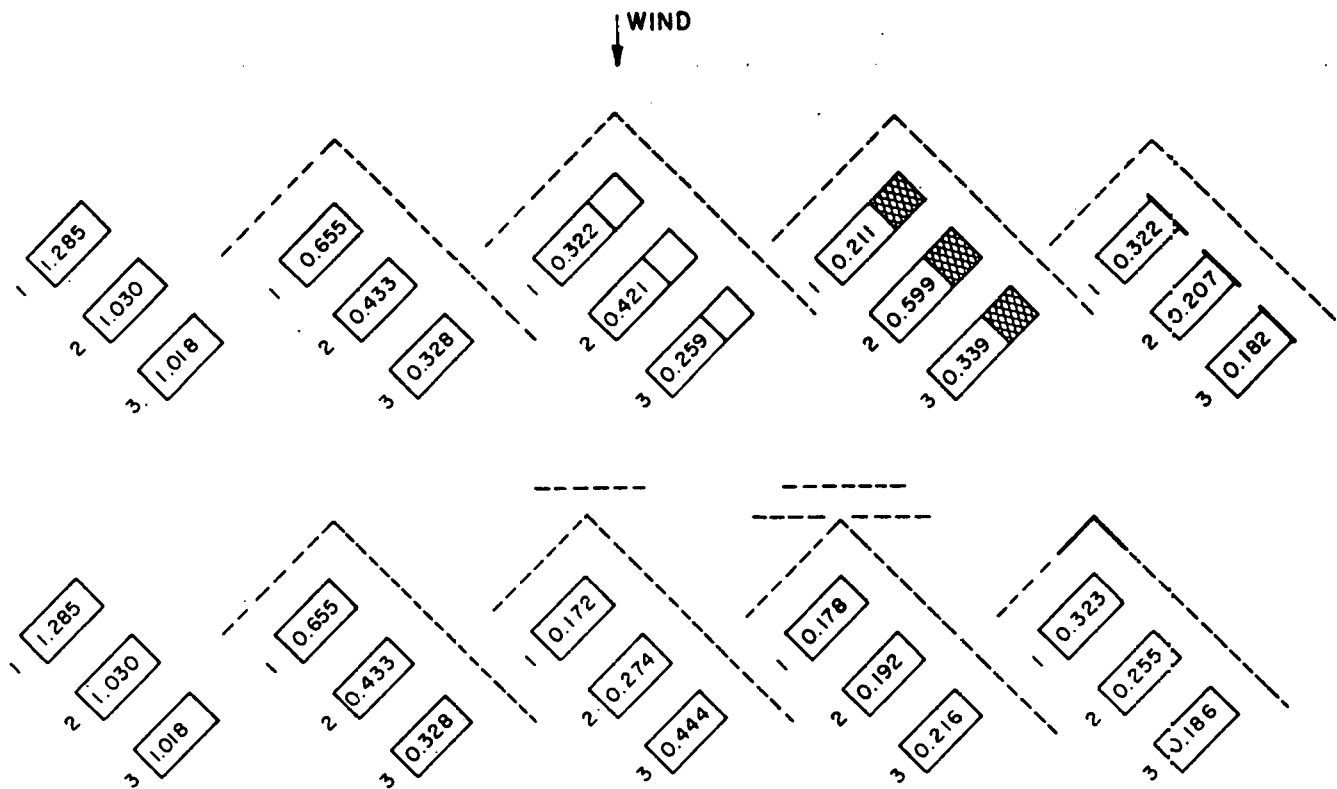

Figure 30a. Normal Force Coefficients for an Array Field, Corner Study with Various Fence and Model Configurations, $x/c = 2.0$, $H/c = 0.25$, $\alpha = 35^\circ$, Nonuniform Flow

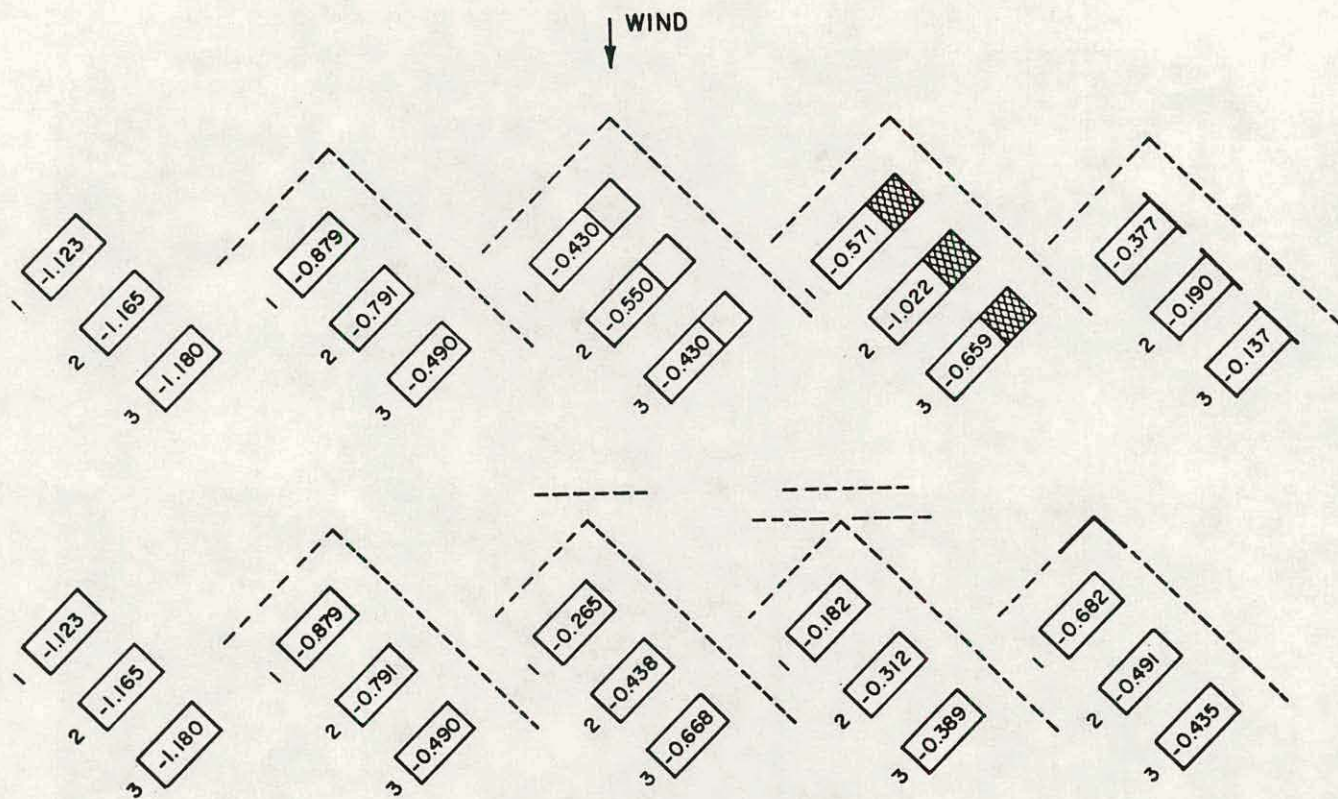

Figure 30b. Normal Force Coefficients for an Array Field, Corner Study with Various Fence and Model Configurations, $x/c = 2.0$, $H/c = 0.25$, $\alpha = 145^\circ$, Nonuniform flow

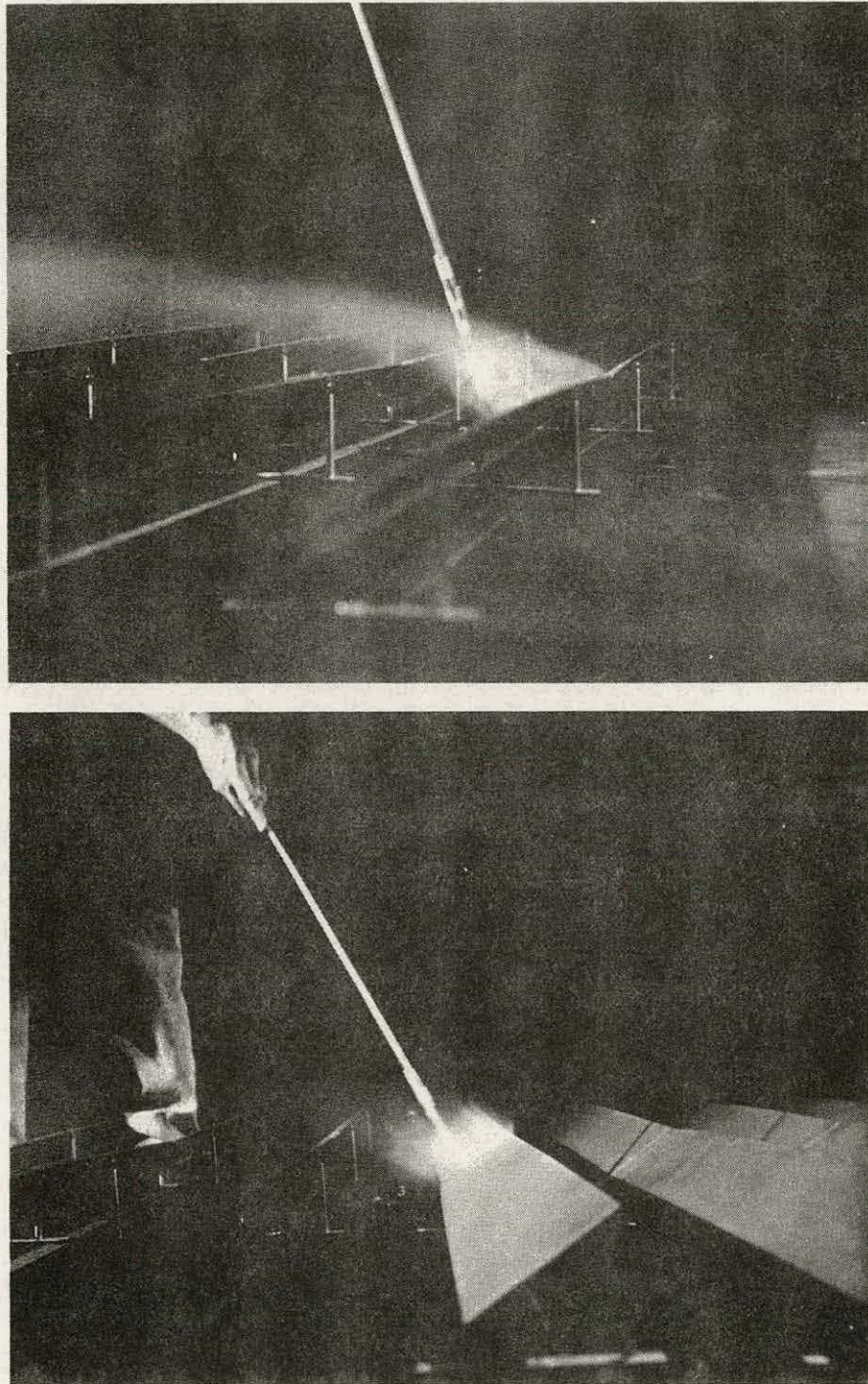

Figure 31a. Flow Visualization for an Array Field, $WD = 0^\circ$

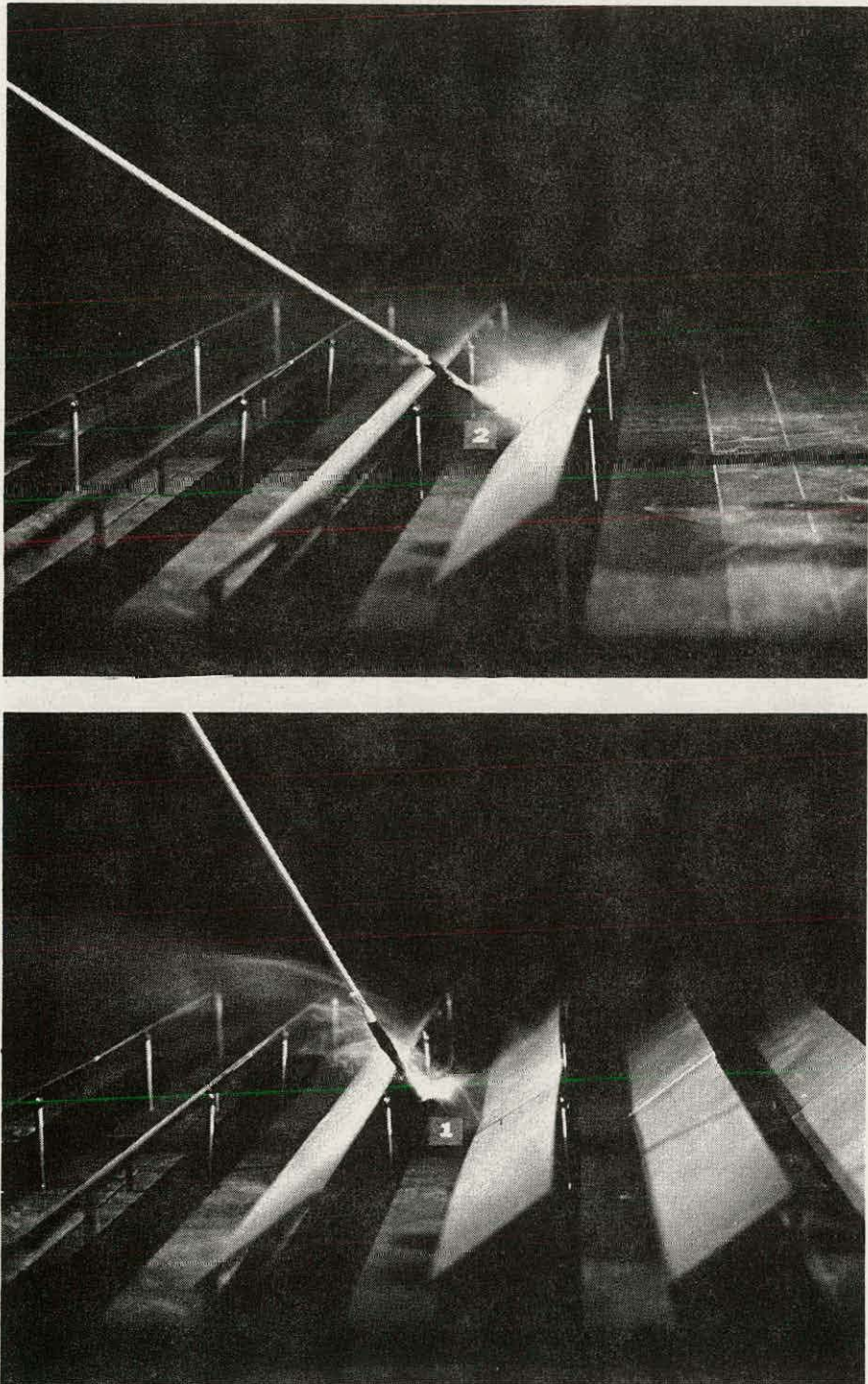

Figure 31b. Flow Visualization for an Array Field, $WD = 0^\circ$

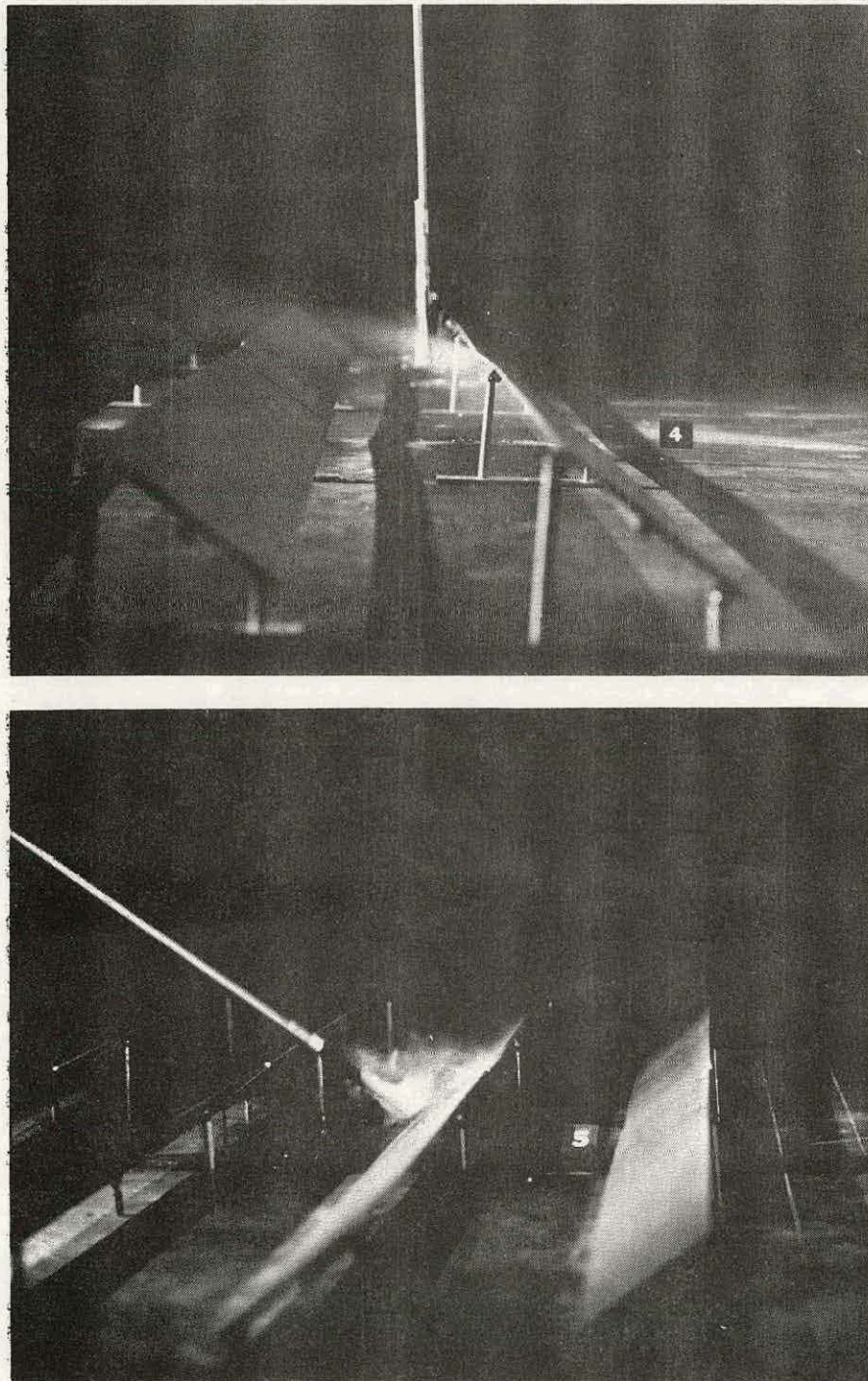

Figure 31c. Flow Visualization for an Array Field, $WD = 0^\circ$

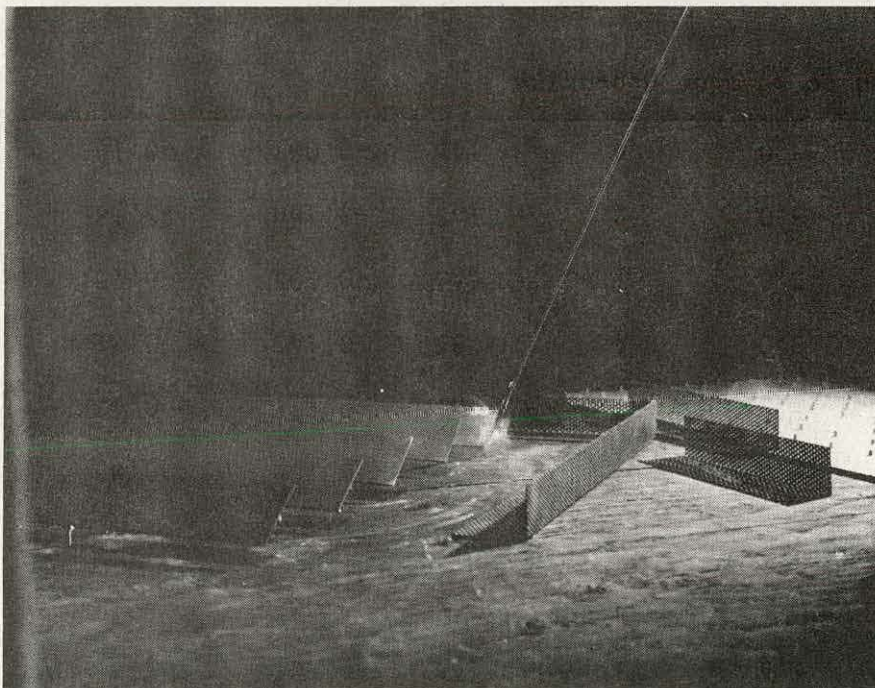

Figure 32. Flow Visualization for an Array Field, $WD = 45^\circ$

TABLES

Table 1. Normal Force and Maximum Pressure Difference
for a Single Array in Uniform Flow

File Name	H/c	α	C_N	$\Delta C_{p \text{ max}}$	s_{max}/c
A02001	0.25	20	1.086	1.53	0.98
A03501	0.25	35	1.145	1.45	0.89
A06001	0.25	60	1.283	1.48	0.83
A09001	0.25	90	1.320	1.46	0.59
A12001	0.25	120	-1.320	-1.48	0.29
A14501	0.25	145	-1.024	-1.46	0.06
A16001	0.25	160	-0.885	-1.37	0.05
B02001	0.5	20	1.015	1.66	0.96
B06001	0.5	60	1.523	1.76	0.74
B09001	0.5	90	1.534	1.74	0.42
B12001	0.5	120	-1.440	-1.73	0.18
B16001	0.5	160	-0.936	-1.49	0.04
C02001	∞	20	1.133	1.79	0.97
C03501	∞	35	1.715	2.13	0.91
C06001	∞	60	2.228	2.48	0.71
C09001	∞	90	2.168	2.35	0.42

Table 2. Normal Force and Maximum Pressure Difference
for an Array Field in Uniform Flow, $x/c = 2.0$

File Name	Array #	α	C_N	$\Delta C_{p \max}$	s_{\max}/c
E02001	1	20	0.717	1.06	0.96
E02101	2	20	0.210	0.82	0.73
E02201	5	20	0.267	0.91	0.86
E03501	1	35	1.006	1.24	0.91
E03601	2	35	0.383	0.75	0.26
E03701	5	35	0.100	0.20	0.45
E06001	1	60	1.220	1.39	0.84
E06101	2	60	-0.055	0.32	0.05
E06201	5	60	0.011	-0.04	0.46
E09001	1	90	1.400	1.56	0.58
E09101	2	90	-0.156	-0.28	0.59
E09201	5	90	-0.056	-0.07	0.42
E12001	1	120	-1.419	-1.60	0.27
E12101	2	120	0.277	0.38	0.28
E12201	5	120	-0.026	-0.10	0.92
E14501	1	145	-1.021	-1.38	0.04
E14601	2	145	-0.031	-0.11	0.74
E14701	5	145	-0.072	-0.10	0.83
E16001	1	160	-0.734	-1.10	0.05
E16101	2	160	-0.348	-0.48	0.05
E16201	5	160	-0.084	-0.10	0.59

Table 3. Normal Force and Maximum Pressure Difference
for an Array Field in Uniform Flow,
 $x/c = 1.5$ and 3.0

File Name	x/c	Array #	α	C_N	$\Delta C_{p \max}$	s_{\max}/c
D03501	1.5	1	35	1.065	1.32	0.92
D03601	1.5	2	35	0.034	0.43	0.97
D03701	1.5	5	35	0.123	0.25	0.19
D14501	1.5	1	145	-1.076	-1.44	0.05
D14601	1.5	2	145	0.168	0.30	0.08
F03501	3.0	1	35	0.925	1.13	0.97
F03601	3.0	2	35	0.326	0.48	0.26
F03701	3.0	4	35	0.081	0.12	0.95
F14501	3.0	1	145	-0.937	-1.38	0.06
F14601	3.0	2	145	-0.063	-0.08	0.56
F14701	3.0	4	145	-0.116	-0.14	0.74

Table 4. Normal Force and Maximum Pressure Difference
for a Single Array in Nonuniform Flow

File Name	H_f/c	α	C_N^*	$\Delta C_{p \max}^*$	s_{\max}/c
G02001	---	20	0.725	0.96	0.96
G03501	---	35	0.832	0.98	0.85
G06001	---	60	0.918	1.02	0.74
G09001	---	90	0.974	1.05	0.44
G12001	---	120	-0.903	-1.04	0.16
G14501	---	145	-0.710	-0.99	0.05
G16001	---	160	-0.608	-0.87	0.05
G01101	0.25	35	0.504	0.71	0.96
G01201	0.5	35	0.295	0.41	0.96
G01301	0.75	35	0.143	0.18	0.82
G01401	1.0	35	0.099	0.11	0.81
G01501	1.25	35	0.286	0.34	0.85
G02101	0.25	145	-0.577	-0.66	0.32
G02201	0.5	145	-0.309	-0.38	0.56
G02301	0.75	145	-0.120	-0.14	0.54
G02401	1.0	145	-0.066	-0.08	0.08
G02501	1.25	145	-0.196	-0.28	0.06

*referenced to 10 m on prototype

Table 5. Normal Force and Maximum Pressure Difference
for an Array Field in Nonuniform Flow,
 $x/c = 2.0$

File Name	Array #	α	C_N^*	$\Delta C_{p \max}^*$	s_{\max}/c
I02001	1	20	0.521	0.73	0.95
I02101	2	20	0.311	0.38	0.74
I02201	5	20	0.203	0.31	0.90
I03501	1	35	0.645	0.76	0.91
I03601	2	35	0.132	0.29	0.20
I03701	5	35	0.123	0.15	0.74
I06001	1	60	0.829	0.90	0.75
I06101	2	60	0.039	0.34	0.06
I06201	5	60	0.063	0.08	0.83
I09001	1	90	0.874	0.97	0.28
I09101	2	90	-0.109	-0.20	0.57
I09201	5	90	0.034	0.08	0.96
I12001	1	120	-0.841	-0.94	0.17
I12101	2	120	0.101	0.17	0.42
I12201	5	120	-0.031	-0.08	0.92
I14501	1	145	-0.609	-0.83	0.05
I14601	2	145	-0.091	-0.11	0.13
I14701	5	145	-0.062	-0.08	0.78
I16001	1	160	-0.494	-0.71	0.05
I16101	2	160	-0.211	-0.32	0.05
I16201	5	160	-0.066	-0.08	0.59

*referenced to 10 m on prototype

Table 6. Normal Force and Maximum Pressure Difference
for an Array Field in Nonuniform Flow,
 $x/c = 1.5$ and 3.0

File Name	x/c	Array #	α	C_N^*	$\Delta C_{p \max}^*$	s_{\max}/c
H03501	1.5	1	35	0.732	0.85	0.93
H03601	1.5	2	35	0.038	0.29	0.16
H03701	1.5	5	35	0.129	0.18	0.43
H14501	1.5	1	145	-0.606	-0.81	0.05
H14601	1.5	2	145	0.077	0.17	0.05
H14701	1.5	5	145	-0.045	-0.11	0.82
J03501	3.0	1	35	0.708	0.83	0.93
J03601	3.0	2	35	0.278	0.42	0.40
J03701	3.0	4	35	0.143	0.21	0.82
J14501	3.0	1	145	-0.595	-0.78	0.05
J14601	3.0	2	145	-0.164	-0.18	0.56
J14701	3.0	4	145	-0.087	-0.10	0.63

*referenced to 10 m on prototype

Table 7. Normal Force and Maximum Pressure Difference
for an Array Field with a Fence, $H_f/c = 0.75$,
 $P_f = 30\%$, $x_f/c = 1.25$

File Name	Array #	α	C_N^*	$\Delta C_{p \max}^*$	s_{\max}/c
K03501	1	35	0.168	0.20	0.82
K03601	2	35	0.081	0.10	0.53
K03701	5	35	0.092	0.14	0.90
K09001	1	90	0.476	0.53	0.84
K09101	2	90	-0.063	-0.13	0.46
K09201	5	90	0.039	0.08	0.86
K14501	1	145	-0.129	-0.15	0.17
K14601	2	145	-0.048	-0.06	0.76
K14701	5	145	-0.045	-0.07	0.77
K16001	1	160	-0.041	-0.06	0.11
K16101	2	160	-0.011	-0.03	0.82
K16201	5	160	-0.050	-0.07	0.61

*referenced to 10 m on prototype

Table 8. Normal Force and Maximum Pressure Difference
for an Array Field with a Fence, $H_f/c = 0.75$,
 $P_f = 30\%$, $x_f/c = 2.5$

File Name	Array #	α	C_N^*	$\Delta C_{p \max}^*$	s_{\max}/c
L03501	1	35	0.119	0.13	0.58
L03601	2	35	0.083	0.11	0.83
L03701	5	35	0.104	0.13	0.84
L09001	1	90	0.335	0.38	0.83
L09101	2	90	-0.020	-0.04	0.44
L09201	5	90	0.042	0.08	0.92
L14501	1	145	-0.115	-0.13	0.73
L14601	2	145	-0.056	-0.08	0.77
L14701	5	145	-0.043	-0.08	0.85
L16001	1	160	-0.029	-0.06	0.12
L16101	2	160	-0.024	-0.03	0.58
L16201	5	160	-0.052	-0.08	0.58

*referenced to 10 m on prototype

Table 9. Normal Force and Maximum Pressure Difference
for an Array Field with a Fence, $H_f/c = 0.75$,
 $P_f = 30\%$, $x_f/c = 5.0$

File Name	Array #	α	C_N^*	$\Delta C_{p \max}^*$	s_{\max}/c
M03501	1	35	0.097	0.13	0.83
M03601	2	35	0.102	0.14	0.84
M03701	5	35	0.122	0.17	0.95
M09001	1	90	0.266	0.34	0.82
M09101	2	90	0.013	0.03	0.24
M09201	5	90	0.050	0.08	0.96
M14501	1	145	-0.148	-0.27	0.44
M14601	2	145	-0.060	-0.10	0.77
M14701	5	145	-0.049	-0.08	0.76
M16001	1	160	-0.048	-0.06	0.28
M16101	2	160	-0.049	-0.07	0.60
M16201	5	160	-0.063	-0.08	0.55

*referenced to 10 m on prototype

Table 10. Normal Force and Maximum Pressure Difference for an Array Field with a Fence of Various Height and Porosity

File Name	P_f	H_f/c	Array #	α	C_N	$\Delta C_{p \max}^*$	s_{\max}/c
N11101	30%	0.25	1	35	0.339	0.49	0.96
O11101	30%	0.25	2	35	0.170	0.22	0.41
N11201	30%	0.5	1	35	0.195	0.27	0.95
O11201	30%	0.5	2	35	0.141	0.20	0.89
N11401	30%	1.0	1	35	0.094	0.11	0.42
O11401	30%	1.0	2	35	0.052	0.08	0.43
N11501	30%	1.25	1	35	0.153	0.20	0.91
O11501	30%	1.25	2	35	0.077	0.13	0.42
N12101	30%	0.25	1	145	-0.519	-0.64	0.15
O12101	30%	0.25	2	145	-0.010	-0.06	0.76
N12201	30%	0.5	1	145	-0.293	-0.34	0.71
O12201	30%	0.5	2	145	-0.046	-0.10	0.78
N12401	30%	1.0	1	145	-0.052	-0.07	0.18
O12401	30%	1.0	2	145	-0.013	-0.06	0.74
N12501	30%	1.25	1	145	-0.077	-0.13	0.14
O12501	30%	1.25	2	145	-0.010	-0.03	0.74
N01301	0%	0.75	1	35	-0.042	-0.06	0.26
O01301	0%	0.75	2	35	-0.022	-0.04	0.26
N02301	0%	0.75	1	145	0.101	0.15	0.41
O02301	0%	0.75	2	145	0.021	0.06	0.26

*referenced to 10 m on prototype

Table 11. Normal Force and Maximum Pressure Difference
for an Array Field, Edge Study

File Name	Fence	Array #	α	C_N^*	$\Delta C_{p \max}^*$	s_{\max}/c
P03501	✓	1	35	0.083	0.18	0.91
P03601	✓	2	35	0.073	0.17	0.92
P03701	✓	5	35	0.137	0.29	0.94
P14501	✓	1	145	-0.056	-0.08	0.83
P14601	✓	2	145	-0.038	-0.08	0.83
P14701	✓	5	145	-0.148	-0.17	0.73
Q03501	---	1	35	0.524	0.78	0.95
Q03601	---	2	35	0.150	0.32	0.92
Q03701	---	5	35	0.225	0.46	0.95
Q14501	---	1	145	-0.504	-0.71	0.05
Q14601	---	2	145	-0.200	-0.34	0.06
Q14701	---	5	145	-0.227	-0.36	0.06

*referenced to 10 m on prototype

Table 12. Normal Force and Maximum Pressure Difference
for an Array Field, No Fence, Corner Study

File Name	MC	Array #	α	C_N^*	$\Delta C_{p \max}^*$	s_{\max}/c
U03501	0	1	35	1.285	1.48	0.90
U03601	0	2	35	1.030	1.27	0.90
U03701	0	3	35	1.018	1.26	0.90
U14501	0	1	145	-1.123	-2.34	0.03
U14601	0	2	145	-1.165	-2.04	0.03
U14701	0	3	145	-1.180	-2.03	0.03
V03501	1	1	35	0.697	1.36	0.83
V03601	1	2	35	0.546	0.76	0.81
V03701	1	3	35	0.531	0.76	0.81
V14501	1	1	145	-0.693	-1.13	0.24
V14601	1	2	145	-0.595	-0.90	0.21
V14701	1	3	145	-0.638	-0.97	0.21

*referenced to 10 m on prototype

Table 13. Normal Force and Maximum Pressure Difference for an Array Field with Various Fences, Corner Study

File Name	FC	Array #	α	C_N^*	$\Delta C_{p, \max}^*$	s_{\max}/c
R01101	1	1	35	0.655	1.93	0.96
S01101	1	2	35	0.433	1.09	0.96
T01101	1	3	35	0.328	0.62	0.96
R02101	1	1	145	0.879	-1.04	0.41
S02101	1	2	145	-0.791	-1.02	0.04
T02101	1	3	145	-0.490	-0.53	0.46
R01201	2	1	35	0.172	0.52	0.96
S01201	2	2	35	0.274	0.71	0.96
T01201	2	3	35	0.444	1.22	0.96
R02201	2	1	145	-0.265	-0.28	0.56
S02201	2	2	145	-0.438	-0.49	0.43
T02201	2	3	145	-0.668	-0.76	0.39
R01301	3	1	35	0.178	0.52	0.96
S01301	3	2	35	0.192	0.52	0.96
T01301	3	3	35	0.216	0.67	0.96
R02301	3	1	145	-0.182	-0.20	0.73
S02301	3	2	145	-0.312	-0.34	0.58
T02301	3	3	145	-0.389	-0.43	0.42

*referenced to 10 m on prototype

Table 14. Normal Force and Maximum Pressure Difference
for an Array Field with Various Fences,
MC = 1, Corner Study

File Name	FC	Array #	α	C_N^*	$\Delta C_p^*_{max}$	s_{max}/c
R11101	1	1	35	0.322	0.77	0.96
S11101	1	2	35	0.421	0.78	0.96
T11101	1	3	35	0.259	0.34	0.84
R12101	1	1	145	-0.430	-0.50	0.43
S12101	1	2	145	-0.550	-0.64	0.40
T12101	1	3	145	-0.430	-0.50	0.27
R11201	2	1	35	0.141	0.27	0.97
S11201	2	2	35	0.172	0.31	0.97
T11201	2	3	35	0.246	0.50	0.97
R12201	2	1	145	-0.255	-0.29	0.43
S12201	2	2	145	-0.283	-0.34	0.38
T12201	2	3	145	-0.368	-0.43	0.29
R11301	3	1	35	0.105	0.20	0.96
S11301	3	2	35	0.140	0.27	0.96
T11301	3	3	35	0.129	0.22	0.96
R12301	3	1	145	-0.153	-0.17	0.43
S12301	3	2	145	-0.217	-0.27	0.43
T12301	3	3	145	-0.209	-0.25	0.43

*referenced to 10 m on prototype

Table 15. Normal Force and Maximum Pressure Difference
for an Array Field with Various Models, FC = 1
and 4, Corner Study

File Name	MC	FC	α	Array #	C_N^*	$\Delta C_{p \max}^*$	s_{\max}/c
R21101	2	1	35	1	0.211	0.67	0.96
S21101	2	1	35	2	0.599	1.64	0.96
T21101	2	1	35	3	0.339	0.53	0.96
R22101	2	1	145	1	-0.571	-0.67	0.72
S22101	2	1	145	2	-1.022	-1.19	0.16
T22101	2	1	145	3	-0.659	-0.74	0.42
R31101	3	1	35	1	0.322	0.85	0.96
S31101	3	1	35	2	0.207	0.36	0.96
T31101	3	1	35	3	0.182	0.25	0.96
R32101	3	1	145	1	-0.377	-0.45	0.04
S32101	3	1	145	2	-0.190	-0.21	0.74
T32101	3	1	145	3	-0.137	-0.15	0.61
R01401	0	4	35	1	0.323	0.14	0.82
S01401	0	4	35	2	0.255	0.13	0.83
T01401	0	4	35	3	0.186	0.15	0.83
R02401	0	4	145	1	-0.682	-0.14	0.73
S02401	0	4	145	2	-0.491	-0.10	0.77
T02401	0	4	145	3	-0.435	-0.09	0.76

*referenced to 10 m on prototype

Table 16. Normal Force and Maximum Pressure Difference
for an Array Field with a Fence, $H_f/c = 1.0$,
 $\alpha = 60^\circ$ and 120°

File Name	α	Array #	C_N^*	$\Delta C_{p \max}^*$	s_{\max}/c
N23401	60	1	0.183	0.12	0.54
N24401	60	2	0.025	0.04	0.72
N25401	60	5	0.053	0.05	0.94
N33401	120	1	-0.165	-0.10	0.18
N34401	120	2	-0.015	-0.06	0.28
N35401	120	5	-0.048	-0.05	0.79

*referenced to 10 m on prototype

Table 17. Fence Configurations

FC	H_f/c	x_f/c	P_f
1	0.75	2.5	30%
2	0.75	2.5	30%
3	0.75	2.5	30%
4	0.75	2.5	30%
5	0.75	1.25	30%
6	0.75	5.0	30%
7	0.25	2.5	30%
8	0.5	2.5	30%
9	1.0	2.5	30%
10	1.25	2.5	30%
11	0.25	2.5	0%
12	0.5	2.5	0%
13	0.75	2.5	0%
14	1.0	2.5	0%
15	1.25	2.5	0%

see Figure 22

Table 18. List of Test Configurations

File Name	Flow Profile		WD	Array		H/c	x	a	Array #	FC ¹	MC ²
	Uniform	1/7 ch		Single	Multiple						
A02001	✓		0	✓		0.25	-	20	-	-	0
A03501	✓		0	✓		0.25	-	35	-	-	0
A06001	✓		0	✓		0.25	-	60	-	-	0
A09001	✓		0	✓		0.25	-	90	-	-	0
A12001	✓		0	✓		0.25	-	120	-	-	0
A14501	✓		0	✓		0.25	-	145	-	-	0
A16001	✓		0	✓		0.25	-	160	-	-	0
B02001	✓		0	✓		0.5	-	20	-	-	0
B06001	✓		0	✓		0.5	-	60	-	-	0
B09001	✓		0	✓		0.5	-	90	-	-	0
B12001	✓		0	✓		0.5	-	120	-	-	0
E16001	✓		0	✓		0.5	-	160	-	-	0
C02001	✓		0	✓		∞	-	20	-	-	0
C03501	✓		0	✓		∞	-	35	-	-	0
C06001	✓		0	✓		∞	-	60	-	-	0
C09001	✓		0	✓		∞	-	90	-	-	0
D02001	✓		0		✓	0.25	1.5e	20	1	-	0
D02101	✓		0		✓	0.25	1.5e	20	2	-	0
D02201	✓		0		✓	0.25	1.5e	20	5	-	0
D03501	✓		0		✓	0.25	1.5e	35	1	-	0
D03601	✓		0		✓	0.25	1.5e	35	2	-	0
D03701	✓		0		✓	0.25	1.5e	35	5	-	0
D14501	✓		0		✓	0.25	1.5e	145	1	-	0
D14601	✓		0		✓	0.25	1.5e	145	2	-	0
D16001	✓		0		✓	0.25	1.5e	160	1	-	0
D16101	✓		0		✓	0.25	1.5e	160	2	-	0
E02001	✓		0		✓	0.25	2.0e	20	1	-	0
E02101	✓		0		✓	0.25	2.0e	20	2	-	0
E02201	✓		0		✓	0.25	2.0e	20	5	-	0
E03501	✓		0		✓	0.25	2.0e	35	1	-	0
E03601	✓		0		✓	0.25	2.0e	35	2	-	0
E03701	✓		0		✓	0.25	2.0e	35	5	-	0
E06001	✓		0		✓	0.25	2.0e	60	1	-	0
E06101	✓		0		✓	0.25	2.0e	60	2	-	0
E06201	✓		0		✓	0.25	2.0e	60	5	-	0
E09001	✓		0		✓	0.25	2.0e	90	1	-	0
E09101	✓		0		✓	0.25	2.0e	90	2	-	0
E09201	✓		0		✓	0.25	2.0e	90	5	-	0
E12001	✓		0		✓	0.25	2.0e	120	1	-	0
E12101	✓		0		✓	0.25	2.0e	120	2	-	0
E12201	✓		0		✓	0.25	2.0e	120	5	-	0
E14501	✓		0		✓	0.25	2.0e	145	1	-	0
E14601	✓		0		✓	0.25	2.0e	145	2	-	0
E14701	✓		0		✓	0.25	2.0e	145	5	-	0
E16001	✓		0		✓	0.25	2.0e	160	1	-	0
E16101	✓		0		✓	0.25	2.0e	160	2	-	0
E16201	✓		0		✓	0.25	2.0e	160	5	-	0
F03501	✓		0		✓	0.25	3.0e	35	1	-	0

¹defined in Table 17²defined in Figure 24

Table 18. (continued)

File Name	Flow Profile		WD	Array		H/c	x	a	Array #	FC	MC
	Uniform	1/7 th		Single	Multiple						
F03601	✓		0		✓	0.25	3.0c	35	2	-	0
F03701	✓		0		✓	0.25	3.0c	35	4	-	0
F06001	✓		0		✓	0.25	3.0c	60	1	-	0
F06101	✓		0		✓	0.25	3.0c	60	2	-	0
F06201	✓		0		✓	0.25	3.0c	60	4	-	0
F12001	✓		0		✓	0.25	3.0c	120	1	-	0
F12101	✓		0		✓	0.25	3.0c	120	2	-	0
F12201	✓		0		✓	0.25	3.0c	120	4	-	0
F14501	✓		0		✓	0.25	3.0c	145	1	-	0
F14601	✓		0		✓	0.25	3.0c	145	2	-	0
F14701	✓		0		✓	0.25	3.0c	145	4	-	0
G02001		✓	0	✓		0.25	-	20	-	-	0
G03501		✓	0	✓		0.25	-	35	-	-	0
G06001		✓	0	✓		0.25	-	60	-	-	0
G09001		✓	0	✓		0.25	-	90	-	-	0
G12001		✓	0	✓		0.25	-	120	-	-	0
G14501		✓	0	✓		0.25	-	145	-	-	0
G16001		✓	0	✓		0.25	-	160	-	-	0
G01101		✓	0	✓		0.25	-	35	-	7	0
G01201		✓	0	✓		0.25	-	35	-	8	0
G01301		✓	0	✓		0.25	-	35	-	1	0
G01401		✓	0	✓		0.25	-	35	-	9	0
G01501		✓	0	✓		0.25	-	35	-	10	0
G02101		✓	0	✓		0.25	-	145	-	7	0
G02201		✓	0	✓		0.25	-	145	-	8	0
G02301		✓	0	✓		0.25	-	145	-	1	0
G02401		✓	0	✓		0.25	-	145	-	9	0
G02501		✓	0	✓		0.25	-	145	-	10	0
H02001		✓	0		✓	0.25	1.5c	20	1	-	0
H02101		✓	0		✓	0.25	1.5c	20	2	-	0
H02201		✓	0		✓	0.25	1.5c	20	5	-	0
H03501		✓	0		✓	0.25	1.5c	35	1	-	0
H03601		✓	0		✓	0.25	1.5c	35	2	-	0
H03701		✓	0		✓	0.25	1.5c	35	5	-	0
H14501		✓	0		✓	0.25	1.5c	145	1	-	0
H14601		✓	0		✓	0.25	1.5c	145	2	-	0
H14701		✓	0		✓	0.25	1.5c	145	5	-	0
H16001		✓	0		✓	0.25	1.5c	160	1	-	0
H16101		✓	0		✓	0.25	1.5c	160	2	-	0
H16201		✓	0		✓	0.25	1.5c	160	5	-	0
I02001		✓	0		✓	0.25	2.0c	20	1	-	0
I02101		✓	0		✓	0.25	2.0c	20	2	-	0
I02201		✓	0		✓	0.25	2.0c	20	5	-	0
I03501		✓	0		✓	0.25	2.0c	35	1	-	0
I03601		✓	0		✓	0.25	2.0c	35	2	-	0
I03701		✓	0		✓	0.25	2.0c	35	5	-	0
I06001		✓	0		✓	0.25	2.0c	60	1	-	0
I06101		✓	0		✓	0.25	2.0c	60	2	-	0

Table 18. (continued)

File Name	Flow Profile		WD	Array		H/c	x	a	Array #	FC	NC
	Uniform	1/7 th		Single	Multiple						
I06201	/		0	/		0.25	2.0c	60	5	-	0
I09001	/		0	/		0.25	2.0c	90	1	-	0
I09101	/		0	/		0.25	2.0c	90	2	-	0
I09201	/		0	/		0.25	2.0c	90	5	-	0
I12001	/		0	/		0.25	2.0c	120	1	-	0
I12101	/		0	/		0.25	2.0c	120	2	-	0
I12201	/		0	/		0.25	2.0c	120	5	-	0
I14501	/		0	/		0.25	2.0c	145	1	-	0
I14601	/		0	/		0.25	2.0c	145	2	-	0
I14701	/		0	/		0.25	2.0c	145	5	-	0
I16001	/		0	/		0.25	2.0c	160	1	-	0
I16101	/		0	/		0.25	2.0c	160	2	-	0
I16201	/		0	/		0.25	2.0c	160	5	-	0
J03501	/		0	/		0.25	3.0c	35	1	-	0
J03601	/		0	/		0.25	3.0c	35	2	-	0
J03701	/		0	/		0.25	3.0c	35	4	-	0
J06001	/		0	/		0.25	3.0c	60	1	-	0
J06101	/		0	/		0.25	3.0c	60	2	-	0
J06201	/		0	/		0.25	3.0c	60	4	-	0
J12001	/		0	/		0.25	3.0c	120	1	-	0
J12101	/		0	/		0.25	3.0c	120	2	-	0
J12201	/		0	/		0.25	3.0c	120	4	-	0
J14501	/		0	/		0.25	3.0c	145	1	-	0
J14601	/		0	/		0.25	3.0c	145	2	-	0
J14701	/		0	/		0.25	3.0c	145	4	-	0
K03501	/		0	/		0.25	2.0c	35	1	5	0
K03601	/		0	/		0.25	2.0c	35	2	5	0
K03701	/		0	/		0.25	2.0c	35	5	5	0
K09001	/		0	/		0.25	2.0c	90	1	5	0
K09101	/		0	/		0.25	2.0c	90	2	5	0
K09201	/		0	/		0.25	2.0c	90	5	5	0
K14501	/		0	/		0.25	2.0c	145	1	5	0
K14601	/		0	/		0.25	2.0c	145	2	5	0
K14701	/		0	/		0.25	2.0c	145	5	5	0
K16001	/		0	/		0.25	2.0c	160	1	5	0
K16101	/		0	/		0.25	2.0c	160	2	5	0
K16201	/		0	/		0.25	2.0c	160	5	5	0
L03501	/		0	/		0.25	2.0c	35	1	1	0
L03601	/		0	/		0.25	2.0c	35	2	1	0
L03701	/		0	/		0.25	2.0c	35	5	1	0
L09001	/		0	/		0.25	2.0c	90	1	1	0
L09101	/		0	/		0.25	2.0c	90	2	1	0
L09201	/		0	/		0.25	2.0c	90	5	1	0
L14501	/		0	/		0.25	2.0c	145	1	1	0
L14601	/		0	/		0.25	2.0c	145	2	1	0
L14701	/		0	/		0.25	2.0c	145	5	1	0
L16001	/		0	/		0.25	2.0c	160	1	1	0
L16101	/		0	/		0.25	2.0c	160	2	1	0

Table 18. (continued)

File Name	Flow Profile		WD	Array		H/c	x	α	Array θ	FC	MC
	Uniform	1/7 th		Single	Multiple						
L16201	✓		0		✓	0.25	2.0c	160	5	1	0
M03501	✓		0		✓	0.25	2.0c	35	1	6	0
M03601	✓		0		✓	0.25	2.0c	35	2	6	0
M03701	✓		0		✓	0.25	2.0c	35	5	6	0
M09001	✓		0		✓	0.25	2.0c	90	1	6	0
M09101	✓		0		✓	0.25	2.0c	90	2	6	0
M09201	✓		0		✓	0.25	2.0c	90	5	6	0
M14501	✓		0		✓	0.25	2.0c	145	1	6	0
M14601	✓		0		✓	0.25	2.0c	145	2	6	0
M14701	✓		0		✓	0.25	2.0c	145	5	6	0
M16001	✓		0		✓	0.25	2.0c	160	1	6	0
M16101	✓		0		✓	0.25	2.0c	160	2	6	0
M16201	✓		0		✓	0.25	2.0c	160	5	6	0
N01101	✓		0		✓	0.25	2.0c	35	1	11	0
N01201	✓		0		✓	0.25	2.0c	35	1	12	0
N01301	✓		0		✓	0.25	2.0c	35	1	13	0
N01401	✓		0		✓	0.25	2.0c	35	1	14	0
N01501	✓		0		✓	0.25	2.0c	35	1	15	0
N02101	✓		0		✓	0.25	2.0c	145	1	11	0
N02201	✓		0		✓	0.25	2.0c	145	1	12	0
N02301	✓		0		✓	0.25	2.0c	145	1	13	0
N02401	✓		0		✓	0.25	2.0c	145	1	14	0
N02501	✓		0		✓	0.25	2.0c	145	1	15	0
N11101	✓		0		✓	0.25	2.0c	35	1	7	0
N11201	✓		0		✓	0.25	2.0c	35	1	8	0
N11401	✓		0		✓	0.25	2.0c	35	1	9	0
N11501	✓		0		✓	0.25	2.0c	35	1	10	0
N12101	✓		0		✓	0.25	2.0c	145	1	7	0
N12201	✓		0		✓	0.25	2.0c	145	1	8	0
N12401	✓		0		✓	0.25	2.0c	145	1	9	0
N12501	✓		0		✓	0.25	2.0c	145	1	10	0
N23401	✓		0		✓	0.25	2.0c	60	1	9	0
N24401	✓		0		✓	0.25	2.0c	60	2	9	0
N25401	✓		0		✓	0.25	2.0c	60	5	9	0
N33401	✓		0		✓	0.25	2.0c	120	1	9	0
N34401	✓		0		✓	0.25	2.0c	120	2	9	0
N35401	✓		0		✓	0.25	2.0c	120	5	9	0
O01101	✓		0		✓	0.25	2.0c	35	2	11	0
O01201	✓		0		✓	0.25	2.0c	35	2	12	0
O01301	✓		0		✓	0.25	2.0c	35	2	13	0
O01401	✓		0		✓	0.25	2.0c	35	2	14	0
O01501	✓		0		✓	0.25	2.0c	35	2	15	0
O02101	✓		0		✓	0.25	2.0c	145	2	11	0
O02201	✓		0		✓	0.25	2.0c	145	2	12	0
O02301	✓		0		✓	0.25	2.0c	145	2	13	0
O02401	✓		0		✓	0.25	2.0c	145	2	14	0
O02501	✓		0		✓	0.25	2.0c	145	2	15	0
O11101	✓		0		✓	0.25	2.0c	35	2	7	0

Table 18. (continued)

File Name	Flow Profile		WD	Array		H/c	x	a	Array #	FC	MC
	Uniform	1/7 th		Single	Multiple						
O11201	✓		0		✓	0.25	2.0c	35	2	8	0
O11401	✓		0		✓	0.25	2.0c	35	2	9	0
O11501	✓		0		✓	0.25	2.0c	35	2	10	0
O12101	✓		0		✓	0.25	2.0c	145	2	7	0
O12201	✓		0		✓	0.25	2.0c	145	2	8	0
O12401	✓		0		✓	0.25	2.0c	145	2	9	0
O12501	✓		0		✓	0.25	2.0c	145	2	10	0
P03501	✓		0		(edge)	0.25	2.0c	35	1	1	0
P03601	✓		0		(edge)	0.25	2.0c	35	2	1	0
P03701	✓		0		(edge)	0.25	2.0c	35	5	1	0
P14501	✓		0		(edge)	0.25	2.0c	145	1	1	0
P14601	✓		0		(edge)	0.25	2.0c	145	2	1	0
P14701	✓		0		(edge)	0.25	2.0c	145	5	1	0
Q03501	✓		0		(edge)	0.25	2.0c	35	1	-	0
Q03601	✓		0		(edge)	0.25	2.0c	35	2	-	0
Q03701	✓		0		(edge)	0.25	2.0c	35	5	-	0
Q14501	✓		0		(edge)	0.25	2.0c	145	1	-	0
Q14601	✓		0		(edge)	0.25	2.0c	145	2	-	0
Q14701	✓		0		(edge)	0.25	2.0c	145	5	-	0
R01101	✓		45		✓	0.25	2.0c	35	1	1	0
R02101	✓		45		✓	0.25	2.0c	145	1	1	0
R01201	✓		45		✓	0.25	2.0c	35	1	2	0
R02201	✓		45		✓	0.25	2.0c	145	1	2	0
R01301	✓		45		✓	0.25	2.0c	35	1	3	0
R02301	✓		45		✓	0.25	2.0c	145	1	3	0
R01401	✓		45		✓	0.25	2.0c	35	1	4	0
R02401	✓		45		✓	0.25	2.0c	145	1	4	0
R11101	✓		45		✓	0.25	2.0c	35	1	1	1
R12101	✓		45		✓	0.25	2.0c	145	1	1	1
R11201	✓		45		✓	0.25	2.0c	35	1	2	1
R12201	✓		45		✓	0.25	2.0c	145	1	2	1
R11301	✓		45		✓	0.25	2.0c	35	1	3	1
R12301	✓		45		✓	0.25	2.0c	145	1	3	1
R21101	✓		45		✓	0.25	2.0c	35	1	1	2
R22101	✓		45		✓	0.25	2.0c	145	1	1	2
R31101	✓		45		✓	0.25	2.0c	35	1	1	3
R32101	✓		45		✓	0.25	2.0c	145	1	1	3
S01101	✓		45		✓	0.25	2.0c	35	2	1	0
S02101	✓		45		✓	0.25	2.0c	145	2	1	0
S01201	✓		45		✓	0.25	2.0c	35	2	2	0
S02201	✓		45		✓	0.25	2.0c	145	2	2	0
S01301	✓		45		✓	0.25	2.0c	35	2	3	0
S02301	✓		45		✓	0.25	2.0c	145	2	3	0
S01401	✓		45		✓	0.25	2.0c	35	2	4	0
S02401	✓		45		✓	0.25	2.0c	145	2	4	0
S11101	✓		45		✓	0.25	2.0c	35	2	1	1
S12101	✓		45		✓	0.25	2.0c	145	2	1	1
S11201	✓		45		✓	0.25	2.0c	35	2	2	1

Table 18. (continued)

File Name	Flow Profile		WD	Array		H/c	x	α	Array #	FC	MC
	Uniform	1/7 th		Single	Multiple						
S12201	✓		45		✓	0.25	2.0c	145	2	2	1
S11301	✓		45		✓	0.25	2.0c	35	2	3	1
S12301	✓		45		✓	0.25	2.0c	145	2	3	1
S21101	✓		45		✓	0.25	2.0c	35	2	1	2
S22101	✓		45		✓	0.25	2.0c	145	2	1	2
S31101	✓		45		✓	0.25	2.0c	35	2	1	3
S32101	✓		45		✓	0.25	2.0c	145	2	1	3
T01101	✓		45		✓	0.25	2.0c	35	3	1	0
T02101	✓		45		✓	0.25	2.0c	145	3	1	0
T01201	✓		45		✓	0.25	2.0c	35	3	2	0
T02201	✓		45		✓	0.25	2.0c	145	3	2	0
T01301	✓		45		✓	0.25	2.0c	35	3	3	0
T02301	✓		45		✓	0.25	2.0c	145	3	3	0
T01401	✓		45		✓	0.25	2.0c	35	3	4	0
T02401	✓		45		✓	0.25	2.0c	145	3	4	0
T11101	✓		45		✓	0.25	2.0c	35	3	1	1
T12101	✓		45		✓	0.25	2.0c	145	3	1	1
T11201	✓		45		✓	0.25	2.0c	35	3	2	1
T12201	✓		45		✓	0.25	2.0c	145	3	2	1
T11301	✓		45		✓	0.25	2.0c	35	3	3	1
T12301	✓		45		✓	0.25	2.0c	145	3	3	1
T21101	✓		45		✓	0.25	2.0c	35	3	1	2
T22101	✓		45		✓	0.25	2.0c	145	3	1	2
T31101	✓		45		✓	0.25	2.0c	35	3	1	3
T32101	✓		45		✓	0.25	2.0c	145	3	1	3
U03501	✓		45		✓	0.25	2.0c	35	1	-	0
U03601	✓		45		✓	0.25	2.0c	35	2	-	0
U03701	✓		45		✓	0.25	2.0c	35	3	-	0
U14501	✓		45		✓	0.25	2.0c	145	1	-	0
U14601	✓		45		✓	0.25	2.0c	145	2	-	0
U14701	✓		45		✓	0.25	2.0c	145	3	-	0
V03501	✓		45		✓	0.25	2.0c	35	1	-	1
V03601	✓		45		✓	0.25	2.0c	35	2	-	1
V03701	✓		45		✓	0.25	2.0c	35	3	-	1
V14501	✓		45		✓	0.25	2.0c	145	1	-	1
V14601	✓		45		✓	0.25	2.0c	145	2	-	1
V14701	✓		45		✓	0.25	2.0c	145	3	-	1
W03501	✓		0		(edge)	0.25	2.0c	35	1	-	0 (1:12)
W03601	✓		0		(edge)	0.25	2.0c	35	2	-	0 (1:12)
W03701	✓		0		(edge)	0.25	2.0c	35	5	-	0 (1:12)
W14501	✓		0		(edge)	0.25	2.0c	145	1	-	0 (1:12)
W14601	✓		0		(edge)	0.25	2.0c	145	2	-	0 (1:12)
W14701	✓		0		(edge)	0.25	2.0c	145	5	-	0 (1:12)
X03501	✓		0		(edge)	0.25	2.0c	35	1	1	0 (1:12)
X03601	✓		0		(edge)	0.25	2.0c	35	2	1	0 (1:12)
X14501	✓		0		(edge)	0.25	2.0c	145	1	1	0 (1:12)
X14601	✓		0		(edge)	0.25	2.0c	145	2	1	0 (1:12)
Z03501	✓		0	✓		0.25	-	35	-	-	0 (1:12)

APPENDIX B

Pressure Data Referenced to 10 m on Prototype

B-1a

This appendix presents the data supplement consisting of the velocity and turbulent profile of the nonuniform flow, the digitized pressure data referenced to 10 m on prototype and the various plots of pressure distribution along the chord of the solar array.

Pressure coefficients are defined in Section 3.2 on the main report. The pressure tap numbers shown in Appendix B are defined that; on the upstream surface of the solar array, the number runs 1 through 10 from the edge where $s/c = 0$, and on the downstream surface, 20 through 11. The file name for each test configuration is formulated as follows.

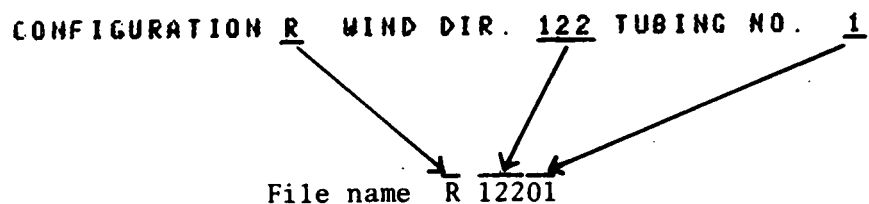

Force and model configurations are schematically explained in Figures 22 and 24 of the main report, respectively. Fence configurations are also tabulated in Table 17 of that report.

List of Run Configurations

File Name	Flow Profile		WD	Array		H/c	x	α	Array #	FC	MC
	Uniform	1/7 th		Single	Multiple						
A02001	✓		0	✓		0.25	-	20	-	-	0
A03501	✓		0	✓		0.25	-	35	-	-	0
A06001	✓		0	✓		0.25	-	60	-	-	0
A09001	✓		0	✓		0.25	-	90	-	-	0
A12001	✓		0	✓		0.25	-	120	-	-	0
A14501	✓		0	✓		0.25	-	145	-	-	0
A16001	✓		0	✓		0.25	-	160	-	-	0
B02001	✓		0	✓		0.5	-	20	-	-	0
B06001	✓		0	✓		0.5	-	60	-	-	0
B09001	✓		0	✓		0.5	-	90	-	-	0
B12001	✓		0	✓		0.5	-	120	-	-	0
B16001	✓		0	✓		0.5	-	160	-	-	0
C02001	✓		0	✓		∞	-	20	-	-	0
C03501	✓		0	✓		∞	-	35	-	-	0
C06001	✓		0	✓		∞	-	60	-	-	0
C09001	✓		0	✓		∞	-	90	-	-	0
D02001	✓		0		✓	0.25	1.5c	20	1	-	0
D02101	✓		0		✓	0.25	1.5c	20	2	-	0
D02201	✓		0		✓	0.25	1.5c	20	5	-	0
D03501	✓		0		✓	0.25	1.5c	35	1	-	0
D03601	✓		0		✓	0.25	1.5c	35	2	-	0
D03701	✓		0		✓	0.25	1.5c	35	5	-	0
D14501	✓		0		✓	0.25	1.5c	145	1	-	0
D14601	✓		0		✓	0.25	1.5c	145	2	-	0
D16001	✓		0		✓	0.25	1.5c	160	1	-	0
D16101	✓		0		✓	0.25	1.5c	160	2	-	0
E02001	✓		0		✓	0.25	2.0c	20	1	-	0
E02101	✓		0		✓	0.25	2.0c	20	2	-	0
E02201	✓		0		✓	0.25	2.0c	20	5	-	0
E03501	✓		0		✓	0.25	2.0c	35	1	-	0
E03601	✓		0		✓	0.25	2.0c	35	2	-	0
E03701	✓		0		✓	0.25	2.0c	35	5	-	0
E06001	✓		0		✓	0.25	2.0c	60	1	-	0
E06101	✓		0		✓	0.25	2.0c	60	2	-	0
E06201	✓		0		✓	0.25	2.0c	60	5	-	0
E09001	✓		0		✓	0.25	2.0c	90	1	-	0
E09101	✓		0		✓	0.25	2.0c	90	2	-	0
E09201	✓		0		✓	0.25	2.0c	90	5	-	0
E12001	✓		0		✓	0.25	2.0c	120	1	-	0
E12101	✓		0		✓	0.25	2.0c	120	2	-	0
E12201	✓		0		✓	0.25	2.0c	120	5	-	0
E14501	✓		0		✓	0.25	2.0c	145	1	-	0
E14601	✓		0		✓	0.25	2.0c	145	2	-	0
E14701	✓		0		✓	0.25	2.0c	145	5	-	0
E16001	✓		0		✓	0.25	2.0c	160	1	-	0
E16101	✓		0		✓	0.25	2.0c	160	2	-	0
E16201	✓		0		✓	0.25	2.0c	160	5	-	0
F03501	✓		0		✓	0.25	3.0c	35	1	-	0

B-3

File Name	Flow Profile		WD	Array		H/c	x	a	Array #	FC	MC
	Uniform	1/7 th		Single	Multiple						
F03601	✓		0		✓	0.25	3.0c	35	2	-	0
F03701	✓		0		✓	0.25	3.0c	35	4	-	0
F06001	✓		0		✓	0.25	3.0c	60	1	-	0
F06101	✓		0		✓	0.25	3.0c	60	2	-	0
F06201	✓		0		✓	0.25	3.0c	60	4	-	0
F12001	✓		0		✓	0.25	3.0c	120	1	-	0
F12101	✓		0		✓	0.25	3.0c	120	2	-	0
F12201	✓		0		✓	0.25	3.0c	120	4	-	0
F14501	✓		0		✓	0.25	3.0c	145	1	-	0
F14601	✓		0		✓	0.25	3.0c	145	2	-	0
F14701	✓		0		✓	0.25	3.0c	145	4	-	0
G02001		✓	0	✓		0.25	-	20	-	-	0
G03501		✓	0	✓		0.25	-	35	-	-	0
G06001		✓	0	✓		0.25	-	60	-	-	0
G09001		✓	0	✓		0.25	-	90	-	-	0
G12001		✓	0	✓		0.25	-	120	-	-	0
G14501		✓	0	✓		0.25	-	145	-	-	0
G16001		✓	0	✓		0.25	-	160	-	-	0
G01101		✓	0	✓		0.25	-	35	-	7	0
G01201		✓	0	✓		0.25	-	35	-	8	0
G01301		✓	0	✓		0.25	-	35	-	1	0
G01401		✓	0	✓		0.25	-	35	-	9	0
G01501		✓	0	✓		0.25	-	35	-	10	0
G02101		✓	0	✓		0.25	-	145	-	7	0
G02201		✓	0	✓		0.25	-	145	-	8	0
G02301		✓	0	✓		0.25	-	145	-	1	0
G02401		✓	0	✓		0.25	-	145	-	9	0
G02501		✓	0	✓		0.25	-	145	-	10	0
H02001		✓	0		✓	0.25	1.5c	20	1	-	0
H02101		✓	0		✓	0.25	1.5c	20	2	-	0
H02201		✓	0		✓	0.25	1.5c	20	5	-	0
H03501		✓	0		✓	0.25	1.5c	35	1	-	0
H03601		✓	0		✓	0.25	1.5c	35	2	-	0
H03701		✓	0		✓	0.25	1.5c	35	5	-	0
H14501		✓	0		✓	0.25	1.5c	145	1	-	0
H14601		✓	0		✓	0.25	1.5c	145	2	-	0
H14701		✓	0		✓	0.25	1.5c	145	5	-	0
H16001		✓	0		✓	0.25	1.5c	160	1	-	0
H16101		✓	0		✓	0.25	1.5c	160	2	-	0
H16201		✓	0		✓	0.25	1.5c	160	5	-	0
I02001		✓	0		✓	0.25	2.0c	20	1	-	0
I02101		✓	0		✓	0.25	2.0c	20	2	-	0
I02201		✓	0		✓	0.25	2.0c	20	5	-	0
I03501		✓	0		✓	0.25	2.0c	35	1	-	0
I03601		✓	0		✓	0.25	2.0c	35	2	-	0
I03701		✓	0		✓	0.25	2.0c	35	5	-	0
I06001		✓	0		✓	0.25	2.0c	60	1	-	0
I06101		✓	0		✓	0.25	2.0c	60	2	-	0

File Name	Flow Profile		WD	Array		H/c	x	a	Array #	FC	MC
	Uniform	1/7 th		Single	Multiple						
I06201	✓		0	✓		0.25	2.0c	60	5	-	0
I09001	✓		0	✓		0.25	2.0c	90	1	-	0
I09101	✓		0	✓		0.25	2.0c	90	2	-	0
I09201	✓		0	✓		0.25	2.0c	90	5	-	0
I12001	✓		0	✓		0.25	2.0c	120	1	-	0
I12101	✓		0	✓		0.25	2.0c	120	2	-	0
I12201	✓		0	✓		0.25	2.0c	120	5	-	0
I14501	✓		0	✓		0.25	2.0c	145	1	-	0
I14601	✓		0	✓		0.25	2.0c	145	2	-	0
I14701	✓		0	✓		0.25	2.0c	145	5	-	0
I16001	✓		0	✓		0.25	2.0c	160	1	-	0
I16101	✓		0	✓		0.25	2.0c	160	2	-	0
I16201	✓		0	✓		0.25	2.0c	160	5	-	0
J03501	✓		0	✓		0.25	3.0c	35	1	-	0
J03601	✓		0	✓		0.25	3.0c	35	2	-	0
J03701	✓		0	✓		0.25	3.0c	35	4	-	0
J06001	✓		0	✓		0.25	3.0c	60	1	-	0
J06101	✓		0	✓		0.25	3.0c	60	2	-	0
J06201	✓		0	✓		0.25	3.0c	60	4	-	0
J12001	✓		0	✓		0.25	3.0c	120	1	-	0
J12101	✓		0	✓		0.25	3.0c	120	2	-	0
J12201	✓		0	✓		0.25	3.0c	120	4	-	0
J14501	✓		0	✓		0.25	3.0c	145	1	-	0
J14601	✓		0	✓		0.25	3.0c	145	2	-	0
J14701	✓		0	✓		0.25	3.0c	145	4	-	0
K03501	✓		0	✓		0.25	2.0c	35	1	5	0
K03601	✓		0	✓		0.25	2.0c	35	2	5	0
K03701	✓		0	✓		0.25	2.0c	35	5	5	0
K09001	✓		0	✓		0.25	2.0c	90	1	5	0
K09101	✓		0	✓		0.25	2.0c	90	2	5	0
K09201	✓		0	✓		0.25	2.0c	90	5	5	0
K14501	✓		0	✓		0.25	2.0c	145	1	5	0
K14601	✓		0	✓		0.25	2.0c	145	2	5	0
K14701	✓		0	✓		0.25	2.0c	145	5	5	0
K16001	✓		0	✓		0.25	2.0c	160	1	5	0
K16101	✓		0	✓		0.25	2.0c	160	2	5	0
K16201	✓		0	✓		0.25	2.0c	160	5	5	0
L03501	✓		0	✓		0.25	2.0c	35	1	1	0
L03601	✓		0	✓		0.25	2.0c	35	2	1	0
L03701	✓		0	✓		0.25	2.0c	35	5	1	0
L09001	✓		0	✓		0.25	2.0c	90	1	1	0
L09101	✓		0	✓		0.25	2.0c	90	2	1	0
L09201	✓		0	✓		0.25	2.0c	90	5	1	0
L14501	✓		0	✓		0.25	2.0c	145	1	1	0
L14601	✓		0	✓		0.25	2.0c	145	2	1	0
L14701	✓		0	✓		0.25	2.0c	145	5	1	0
L16001	✓		0	✓		0.25	2.0c	160	1	1	0
L16101	✓		0	✓		0.25	2.0c	160	2	1	0

B-5

File Name	Flow Profile		WD	Array		H/c	x	α	Array #	FC	MC
	Uniform	1/7 th		Single	Multiple						
L16201	✓		0		✓	0.25	2.0c	160	5	1	0
M03501	✓		0		✓	0.25	2.0c	35	1	6	0
M03601	✓		0		✓	0.25	2.0c	35	2	6	0
M03701	✓		0		✓	0.25	2.0c	35	5	6	0
M09001	✓		0		✓	0.25	2.0c	90	1	6	0
M09101	✓		0		✓	0.25	2.0c	90	2	6	0
M09201	✓		0		✓	0.25	2.0c	90	5	6	0
M14501	✓		0		✓	0.25	2.0c	145	1	6	0
M14601	✓		0		✓	0.25	2.0c	145	2	6	0
M14701	✓		0		✓	0.25	2.0c	145	5	6	0
M16001	✓		0		✓	0.25	2.0c	160	1	6	0
M16101	✓		0		✓	0.25	2.0c	160	2	6	0
M16201	✓		0		✓	0.25	2.0c	160	5	6	0
N01101	✓		0		✓	0.25	2.0c	35	1	11	0
N01201	✓		0		✓	0.25	2.0c	35	1	12	0
N01301	✓		0		✓	0.25	2.0c	35	1	13	0
N01401	✓		0		✓	0.25	2.0c	35	1	14	0
N01501	✓		0		✓	0.25	2.0c	35	1	15	0
N02101	✓		0		✓	0.25	2.0c	145	1	11	0
N02201	✓		0		✓	0.25	2.0c	145	1	12	0
N02301	✓		0		✓	0.25	2.0c	145	1	13	0
N02401	✓		0		✓	0.25	2.0c	145	1	14	0
N02501	✓		0		✓	0.25	2.0c	145	1	15	0
N11101	✓		0		✓	0.25	2.0c	35	1	7	0
N11201	✓		0		✓	0.25	2.0c	35	1	8	0
N11401	✓		0		✓	0.25	2.0c	35	1	9	0
N11501	✓		0		✓	0.25	2.0c	35	1	10	0
N12101	✓		0		✓	0.25	2.0c	145	1	7	0
N12201	✓		0		✓	0.25	2.0c	145	1	8	0
N12401	✓		0		✓	0.25	2.0c	145	1	9	0
N12501	✓		0		✓	0.25	2.0c	145	1	10	0
N23401	✓		0		✓	0.25	2.0c	60	1	9	0
N24401	✓		0		✓	0.25	2.0c	60	2	9	0
N25401	✓		0		✓	0.25	2.0c	60	5	9	0
N33401	✓		0		✓	0.25	2.0c	120	1	9	0
N34401	✓		0		✓	0.25	2.0c	120	2	9	0
N35401	✓		0		✓	0.25	2.0c	120	5	9	0
001101	✓		0		✓	0.25	2.0c	35	2	11	0
001201	✓		0		✓	0.25	2.0c	35	2	12	0
001301	✓		0		✓	0.25	2.0c	35	2	13	0
001401	✓		0		✓	0.25	2.0c	35	2	14	0
001501	✓		0		✓	0.25	2.0c	35	2	15	0
002101	✓		0		✓	0.25	2.0c	145	2	11	0
002201	✓		0		✓	0.25	2.0c	145	2	12	0
002301	✓		0		✓	0.25	2.0c	145	2	13	0
002401	✓		0		✓	0.25	2.0c	145	2	14	0
002501	✓		0		✓	0.25	2.0c	145	2	15	0
011101	✓		0		✓	0.25	2.0c	35	2	7	0

B-6

File Name	Flow Profile		WD	Array		H/c	x	a	Array #	FC	MC
	Uniform	1/7 th		Single	Multiple						
O11201	✓		0	✓		0.25	2.0c	35	2	8	0
O11401	✓		0	✓		0.25	2.0c	35	2	9	0
O11501	✓		0	✓		0.25	2.0c	35	2	10	0
O12101	✓		0	✓		0.25	2.0c	145	2	7	0
O12201	✓		0	✓		0.25	2.0c	145	2	8	0
O12401	✓		0	✓		0.25	2.0c	145	2	9	0
O12501	✓		0	✓		0.25	2.0c	145	2	10	0
P03501	✓		0	(edge)		0.25	2.0c	35	1	1	0
P03601	✓		0	(edge)		0.25	2.0c	35	2	1	0
P03701	✓		0	(edge)		0.25	2.0c	35	5	1	0
P14501	✓		0	(edge)		0.25	2.0c	145	1	1	0
P14601	✓		0	(edge)		0.25	2.0c	145	2	1	0
P14701	✓		0	(edge)		0.25	2.0c	145	5	1	0
Q03501	✓		0	(edge)		0.25	2.0c	35	1	-	0
Q03601	✓		0	(edge)		0.25	2.0c	35	2	-	0
Q03701	✓		0	(edge)		0.25	2.0c	35	5	-	0
Q14501	✓		0	(edge)		0.25	2.0c	145	1	-	0
Q14601	✓		0	(edge)		0.25	2.0c	145	2	-	0
Q14701	✓		0	(edge)		0.25	2.0c	145	5	-	0
R01101	✓		45	✓		0.25	2.0c	35	1	1	0
R02101	✓		45	✓		0.25	2.0c	145	1	1	0
R01201	✓		45	✓		0.25	2.0c	35	1	2	0
R02201	✓		45	✓		0.25	2.0c	145	1	2	0
R01301	✓		45	✓		0.25	2.0c	35	1	3	0
R02301	✓		45	✓		0.25	2.0c	145	1	3	0
R01401	✓		45	✓		0.25	2.0c	35	1	4	0
R02401	✓		45	✓		0.25	2.0c	145	1	4	0
R11101	✓		45	✓		0.25	2.0c	35	1	1	1
R12101	✓		45	✓		0.25	2.0c	145	1	1	1
R11201	✓		45	✓		0.25	2.0c	35	1	2	1
R12201	✓		45	✓		0.25	2.0c	145	1	2	1
R11301	✓		45	✓		0.25	2.0c	35	1	3	1
R12301	✓		45	✓		0.25	2.0c	145	1	3	1
R21101	✓		45	✓		0.25	2.0c	35	1	1	2
R22101	✓		45	✓		0.25	2.0c	145	1	1	2
R31101	✓		45	✓		0.25	2.0c	35	1	1	3
R32101	✓		45	✓		0.25	2.0c	145	1	1	3
S01101	✓		45	✓		0.25	2.0c	35	2	1	0
S02101	✓		45	✓		0.25	2.0c	145	2	1	0
S01201	✓		45	✓		0.25	2.0c	35	2	2	0
S02201	✓		45	✓		0.25	2.0c	145	2	2	0
S01301	✓		45	✓		0.25	2.0c	35	2	3	0
S02301	✓		45	✓		0.25	2.0c	145	2	3	0
S01401	✓		45	✓		0.25	2.0c	35	2	4	0
S02401	✓		45	✓		0.25	2.0c	145	2	4	0
S11101	✓		45	✓		0.25	2.0c	35	2	1	1
S12101	✓		45	✓		0.25	2.0c	145	2	1	1
S11201	✓		45	✓		0.25	2.0c	35	2	2	1

B-7

File Name	Flow Profile		WD	Array		H/c	x	α	Array #	FC	MC
	Uniform	1/7 th		Single	Multiple						
S12201	✓		45		✓	0.25	2.0c	145	2	2	1
S11301	✓		45		✓	0.25	2.0c	35	2	3	1
S12301	✓		45		✓	0.25	2.0c	145	2	3	1
S21101	✓		45		✓	0.25	2.0c	35	2	1	2
S22101	✓		45		✓	0.25	2.0c	145	2	1	2
S31101	✓		45		✓	0.25	2.0c	35	2	1	3
S32101	✓		45		✓	0.25	2.0c	145	2	1	3
T01101	✓		45		✓	0.25	2.0c	35	3	1	0
T02101	✓		45		✓	0.25	2.0c	145	3	1	0
T01201	✓		45		✓	0.25	2.0c	35	3	2	0
T02201	✓		45		✓	0.25	2.0c	145	3	2	0
T01301	✓		45		✓	0.25	2.0c	35	3	3	0
T02301	✓		45		✓	0.25	2.0c	145	3	3	0
T01401	✓		45		✓	0.25	2.0c	35	3	4	0
T02401	✓		45		✓	0.25	2.0c	145	3	4	0
T11101	✓		45		✓	0.25	2.0c	35	3	1	1
T12101	✓		45		✓	0.25	2.0c	145	3	1	1
T11201	✓		45		✓	0.25	2.0c	35	3	2	1
T12201	✓		45		✓	0.25	2.0c	145	3	2	1
T11301	✓		45		✓	0.25	2.0c	35	3	3	1
T12301	✓		45		✓	0.25	2.0c	145	3	3	1
T21101	✓		45		✓	0.25	2.0c	35	3	1	2
T22101	✓		45		✓	0.25	2.0c	145	3	1	2
T31101	✓		45		✓	0.25	2.0c	35	3	1	3
T32101	✓		45		✓	0.25	2.0c	145	3	1	3
U03501	✓		45		✓	0.25	2.0c	35	1	-	0
U03601	✓		45		✓	0.25	2.0c	35	2	-	0
U03701	✓		45		✓	0.25	2.0c	35	3	-	0
U14501	✓		45		✓	0.25	2.0c	145	1	-	0
U14601	✓		45		✓	0.25	2.0c	145	2	-	0
U14701	✓		45		✓	0.25	2.0c	145	3	-	0
V03501	✓		45		✓	0.25	2.0c	35	1	-	1
V03601	✓		45		✓	0.25	2.0c	35	2	-	1
V03701	✓		45		✓	0.25	2.0c	35	3	-	1
V14501	✓		45		✓	0.25	2.0c	145	1	-	1
V14601	✓		45		✓	0.25	2.0c	145	2	-	1
V14701	✓		45		✓	0.25	2.0c	145	3	-	1
W03501	✓		0		(edge)	0.25	2.0c	35	1	-	0 (1:12)
W03601	✓		0		(edge)	0.25	2.0c	35	2	-	0 (1:12)
W03701	✓		0		(edge)	0.25	2.0c	35	5	-	0 (1:12)
W14501	✓		0		(edge)	0.25	2.0c	145	1	-	0 (1:12)
W14601	✓		0		(edge)	0.25	2.0c	145	2	-	0 (1:12)
W14701	✓		0		(edge)	0.25	2.0c	145	5	-	0 (1:12)
X03501	✓		0		(edge)	0.25	2.0c	35	1	1	0 (1:12)
X03601	✓		0		(edge)	0.25	2.0c	35	2	1	0 (1:12)
X14501	✓		0		(edge)	0.25	2.0c	145	1	1	0 (1:12)
X14601	✓		0		(edge)	0.25	2.0c	145	2	1	0 (1:12)
Z03501	✓		0	✓		0.25	-	35	-	-	0 (1:12)

DATA FOR PROJECT 6022 CONFIG. A WIND DIR. 20 TUBING NO. 1				
TAP	MEAN	RMS	MAX	MIN
1	1.131	1.111	1.443	-.917
2	1.149	1.111	2.214	-.576
3	1.066	0.999	2.462	-.287
4	1.033	0.877	3.440	-.133
5	0.955	0.855	4.19	-.057
6	0.866	0.855	5.01	-.185
7	0.777	0.755	5.98	-.324
8	0.688	0.666	7.24	-.411
9	0.599	0.577	8.33	-.466
10	0.511	0.488	9.35	-.455

DATA FOR PROJECT 6022 CONFIG. A WIND DIR. 35 TUBING NO. 1				
TAP	MEAN	RMS	MAX	MIN
1	0.046	0.036	0.081	-.193
2	0.104	0.081	0.233	-.089
3	0.245	0.225	0.37	-.158
4	0.325	0.24	0.524	-.241
5	0.433	0.24	0.591	-.341
6	0.524	0.27	0.735	-.433
7	0.641	0.38	0.87	-.523
8	0.726	0.58	0.98	-.566
9	0.85	0.64	1.026	-.473
10	0.964	0.74	1.102	-.259

DATA FOR PROJECT 6022 CONFIG. A WIND DIR. 60 TUBING NO. 1				
TAP	MEAN	RMS	MAX	MIN
1	0.056	0.048	0.341	-.026
2	0.122	0.108	0.484	-.137
3	0.233	0.211	0.555	-.258
4	0.333	0.311	0.655	-.343
5	0.433	0.411	0.752	-.423
6	0.533	0.511	0.865	-.484
7	0.633	0.611	1.051	-.548
8	0.733	0.711	1.081	-.485
9	0.833	0.811	1.093	-.299
10	0.933	0.911	0.972	-.244

DATA FOR PROJECT 6022 CONFIG. A WIND DIR. 90 TUBING NO. 1				
TAP	MEAN	RMS	MAX	MIN
1	0.313	0.299	0.609	-.043
2	0.433	0.411	0.716	-.249
3	0.533	0.511	0.824	-.364
4	0.633	0.611	0.937	-.423
5	0.733	0.711	1.052	-.523
6	0.833	0.811	1.166	-.523
7	0.933	0.911	1.28	-.486
8	1.033	1.011	1.399	-.349
9	1.133	1.111	1.516	-.288
10	1.233	1.211	1.633	-.294

DATA FOR PROJECT 6022 CONFIG. A WIND DIR. 120 TUBING NO. 1				
TAP	MEAN	RMS	MAX	MIN
1	0.577	0.566	0.895	-.241
2	0.676	0.788	0.953	-.400
3	0.735	0.851	0.963	-.514
4	0.797	0.914	0.957	-.609
5	0.855	0.977	0.964	-.669
6	0.914	1.041	0.964	-.783
7	0.977	1.108	0.964	-.881
8	1.041	1.177	0.964	-.924
9	1.108	1.244	0.964	-.959
10	1.177	1.311	0.964	-.987

DATA FOR PROJECT 6022 CONFIG. A WIND DIR. 145 TUBING NO. 1				
TAP	MEAN	RMS	MAX	MIN
1	0.768	0.71	0.985	-.527
2	0.742	0.50	0.933	-.567
3	0.688	0.35	0.876	-.576
4	0.607	0.27	0.733	-.514
5	0.477	0.19	0.542	-.363
6	0.314	0.18	0.355	-.241
7	0.126	0.17	0.187	-.058
8	0.036	0.19	0.035	-.035
9	0.173	0.23	0.091	-.251
10	0.397	0.28	0.274	-.488

DATA FOR PROJECT 6022 CONFIG. A WIND DIR. 160 TUBING NO. 1

TAP	MEAN	RMS	MAX	MIN	TAP	MEAN	RMS	MAX	MIN
1	.614	.035	.709	.461	11	.787	.070	.530	-1.163
2	.619	.025	.589	.422	12	.783	.065	.528	-1.140
3	.422	.013	.474	.342	13	.775	.063	.578	-1.087
4	.325	.015	.375	.268	14	.776	.065	.533	-1.109
5	.191	.014	.240	.138	15	.769	.064	.581	-1.088
6	.057	.015	.110	.006	16	.763	.061	.585	-1.124
7	.095	.016	.037	.160	17	.756	.054	.559	-1.125
8	.218	.026	.137	.294	18	.754	.052	.573	-1.956
9	.335	.025	.237	.439	19	.743	.046	.574	-1.911
10	.504	.026	.359	.684	20	.737	.048	.564	-1.916

DATA FOR PROJECT 6022 CONFIG. B WIND DIR. 20 TUBING NO. 1

TAP	MEAN	RMS	MAX	MIN	TAP	MEAN	RMS	MAX	MIN
1	.379	.040	.250	.525	11	.714	.038	.578	-1.379
2	.248	.032	.145	.382	12	.746	.039	.604	-1.906
3	.162	.027	.010	.197	13	.727	.037	.603	-1.865
4	.084	.025	.089	.072	14	.743	.038	.605	-1.902
5	.153	.020	.219	.033	15	.729	.032	.616	-1.879
6	.299	.019	.365	.239	16	.767	.035	.646	-1.979
7	.489	.017	.541	.433	17	.750	.036	.627	-1.895
8	.615	.017	.670	.549	18	.761	.040	.622	-1.948
9	.759	.016	.809	.688	19	.746	.047	.597	-1.931
10	.929	.016	.980	.813	20	.777	.060	.566	-1.003

DATA FOR PROJECT 6022 CONFIG. B WIND DIR. 60 TUBING NO. 1

TAP	MEAN	RMS	MAX	MIN	TAP	MEAN	RMS	MAX	MIN
1	.682	.041	.220	-.072	11	.766	.037	.630	-.896
2	.220	.037	.417	.153	12	.789	.038	.641	-.913
3	.479	.037	.598	.346	13	.772	.037	.633	-.911
4	.628	.032	.742	.491	14	.779	.038	.641	-.902
5	.809	.036	.891	.665	15	.763	.037	.543	-.903
6	.923	.029	.963	.764	16	.786	.037	.585	-.934
7	.988	.028	1.069	.779	17	.788	.039	.588	-.904
8	.972	.029	1.117	.732	18	.776	.040	.574	-.919
9	.873	.031	1.054	.646	19	.764	.039	.606	-.913
10	.591	.041	.783	.319	20	.788	.040	.636	-.950

DATA FOR PROJECT 6022 CONFIG. B WIND DIR. 90 TUBING NO. 1

TAP	MEAN	RMS	MAX	MIN	TAP	MEAN	RMS	MAX	MIN
1	.497	.074	.694	.201	11	.755	.038	.593	-.893
2	.700	.062	.865	.467	12	.780	.038	.593	-.879
3	.837	.050	.982	.653	13	.753	.038	.582	-.880
4	.931	.041	1.065	.759	14	.772	.038	.603	-.891
5	.971	.029	1.059	.924	15	.760	.037	.585	-.889
6	.971	.025	1.009	.793	16	.788	.037	.585	-.884
7	.882	.022	.988	.667	17	.789	.038	.585	-.888
8	.837	.024	.735	.482	18	.769	.037	.585	-.881
9	.423	.027	.516	.274	19	.754	.036	.585	-.872
10	.089	.035	.213	-.121	20	.760	.038	.585	-.882

DATA FOR PROJECT 6022 CONFIG. B WIND DIR. 120 TUBING NO. 1

TAP	MEAN	RMS	MAX	MIN	TAP	MEAN	RMS	MAX	MIN
1	.905	.050	1.026	.576	11	.758	.037	.601	-.881
2	.745	.043	.752	.522	12	.758	.038	.601	-.883
3	.974	.029	1.064	.857	13	.749	.038	.629	-.875
4	.947	.021	1.022	.845	14	.764	.038	.638	-.860
5	.846	.017	.777	.658	15	.754	.032	.658	-.860
6	.697	.016	.626	.626	16	.753	.033	.670	-.861
7	.488	.016	.542	.417	17	.747	.033	.606	-.870
8	.308	.017	.349	.213	18	.759	.033	.600	-.871
9	.228	.021	.269	.069	19	.766	.033	.593	-.853
10	.000	.027	.122	-.325	20	.750	.033	.593	-.866

DATA FOR PROJECT 6022 CONFIG. B WIND DIR. 160 TUBING NO. 1

TAP	MEAN	RMS	MAX	MIN	TAP	MEAN	RMS	MAX	MIN
1	.688	.017	.755	.631	11	.855	.070	.660	-1.180
2	.537	.019	.612	.587	12	.885	.064	.660	-1.187
3	.427	.014	.485	.391	13	.855	.062	.660	-1.166
4	.284	.013	.369	.280	14	.855	.050	.663	-1.054
5	.177	.012	.219	.138	15	.834	.051	.663	-1.034
6	.034	.014	.080	.016	16	.823	.048	.663	-1.032
7	.129	.010	.070	.188	17	.823	.045	.663	-1.032
8	.229	.021	.196	.346	18	.823	.046	.663	-1.032
9	.329	.028	.422	.491	19	.799	.046	.663	-1.032
10	.564	.045	.402	.739	20	.799	.046	.663	-1.032

DATA FOR PROJECT 6022 CONFIG. C WIND DIR. 20 TUBING NO. 1

TAP	MEAN	RMS	MAX	MIN
11	-.814	.048	-.678	-1.001
12	-.822	.048	-.686	-1.008
13	-.828	.048	-.693	-1.009
14	-.828	.048	-.693	-1.009
15	-.844	.050	-.699	-1.060
16	-.844	.054	-.699	-1.054
17	-.846	.054	-.699	-1.110
18	-.844	.064	-.699	-1.145
19	-.839	.079	-.494	-1.353
20	-.843	.105	-.430	-1.407

DATA FOR PROJECT 6022 CONFIG. C WIND DIR. 35 TUBING NO. 1

TAP	MEAN	RMS	MAX	MIN
11	-.441	.134	-.074	-1.218
12	-.187	.100	-.104	-.674
13	-.033	.075	-.239	-.387
14	-.246	.056	-.409	-.638
15	-.480	.034	-.604	-.297
16	-.678	.034	-.779	-.541
17	-.857	.029	-.962	-.762
18	-.957	.024	1.047	-.883
19	1.004	.019	1.076	-.937
20	.930	.017	.989	-.870

DATA FOR PROJECT 6022 CONFIG. C WIND DIR. 60 TUBING NO. 1

TAP	MEAN	RMS	MAX	MIN
11	-1.401	.188	-.757	-2.467
12	-1.399	.188	-.757	-2.459
13	-1.405	.189	-.757	-2.466
14	-1.420	.194	-.757	-2.578
15	-1.445	.200	-.757	-2.617
16	-1.441	.204	-.757	-2.438
17	-1.425	.219	-.757	-2.703
18	-1.432	.239	-.757	-2.883
19	-1.434	.237	-.757	-2.899
20	-1.432	.250	-.757	-3.573

DATA FOR PROJECT 6022 CONFIG. C WIND DIR. 90 TUBING NO. 1

TAP	MEAN	RMS	MAX	MIN
11	-1.364	.174	-.478	-2.576
12	-1.338	.179	-.469	-2.427
13	-1.335	.158	-.606	-2.425
14	-1.377	.149	-.720	-2.427
15	-1.357	.142	-.664	-2.445
16	-1.379	.144	-.735	-2.375
17	-1.360	.163	-.864	-2.555
18	-1.360	.170	-.810	-2.432
19	-1.347	.169	-.909	-2.866
20	-1.355	.172	-.915	-2.866

DATA FOR PROJECT 6022 CONFIG. D WIND DIR. 20 TUBING NO. 1

TAP	MEAN	RMS	MAX	MIN
11	-.405	.027	-.305	-.497
12	-.409	.027	-.309	-.505
13	-.411	.025	-.323	-.503
14	-.414	.026	-.323	-.503
15	-.427	.024	-.340	-.507
16	-.437	.026	-.346	-.509
17	-.438	.027	-.355	-.504
18	-.435	.030	-.319	-.506
19	-.430	.035	-.244	-.506
20	-.426	.042	-.217	-.505

DATA FOR PROJECT 6022 CONFIG. D WIND DIR. 21 TUBING NO. 1

TAP	MEAN	RMS	MAX	MIN
11	-.109	.054	-.102	-.369
12	-.025	.060	-.159	-.283
13	-.054	.072	-.300	-.230
14	-.099	.094	-.466	-.184
15	-.011	.120	-.448	-.133
16	-.249	.113	-.288	-.288
17	-.482	.074	-.120	-.482
18	-.523	.062	-.266	-.744
19	-.503	.052	-.188	-.691
20	-.471	.057	-.245	-.742

DATA FOR PROJECT 6022 CONFIG. D WIND DIR. 22 TUBING NO. 1				
TAP	MEAN	RMS	MAX	MIN
1	-.066	.044	.137	-.275
2	-.026	.041	.147	-.183
3	-.026	.044	.160	-.236
4	-.076	.055	.254	-.265
5	-.082	.083	.356	-.263
6	-.038	.109	.433	-.235
7	-.081	.099	.411	-.377
8	-.156	.083	.402	-.425
9	-.198	.077	.282	-.466
10	-.227	.086	.154	-.612

DATA FOR PROJECT 6022 CONFIG. D WIND DIR. 35 TUBING NO. 1				
TAP	MEAN	RMS	MAX	MIN
1	-.007	.032	.101	-.127
2	-.140	.028	.240	-.044
3	-.285	.028	.360	.174
4	-.351	.025	.443	.271
5	-.447	.025	.543	.376
6	-.530	.029	.649	.441
7	-.637	.040	.773	.499
8	-.712	.061	.896	.450
9	-.770	.087	1.012	.417
10	-.747	.138	1.101	.186

DATA FOR PROJECT 6022 CONFIG. D WIND DIR. 36 TUBING NO. 1				
TAP	MEAN	RMS	MAX	MIN
1	-.110	.132	.385	-.513
2	-.075	.145	.425	-.482
3	-.101	.156	.537	-.518
4	-.253	.145	.389	-.688
5	-.506	.088	-.007	-.824
6	-.614	.059	-.423	-.877
7	-.616	.048	-.432	-.825
8	-.620	.047	-.441	-.837
9	-.599	.044	-.448	-.848
10	-.594	.053	-.406	-.870

DATA FOR PROJECT 6022 CONFIG. D WIND DIR. 37 TUBING NO. 1				
TAP	MEAN	RMS	MAX	MIN
1	-.109	.061	.134	-.308
2	-.072	.068	.237	-.277
3	-.047	.077	.276	-.292
4	-.052	.088	.340	-.336
5	-.116	.086	.343	-.399
6	-.224	.070	.108	-.451
7	-.301	.061	-.004	-.511
8	-.328	.066	-.085	-.549
9	-.324	.067	-.048	-.577
10	-.334	.075	-.023	-.837

DATA FOR PROJECT 6022 CONFIG. D WIND DIR. 145 TUBING NO. 1				
TAP	MEAN	RMS	MAX	MIN
1	.721	.070	.950	.450
2	.766	.049	.867	.549
3	.859	.035	.785	.531
4	.586	.028	.691	.468
5	.452	.022	.591	.386
6	.312	.021	.433	.233
7	.123	.020	.262	.045
8	.040	.020	.051	-.113
9	.193	.024	-.105	-.271
10	.403	.030	-.292	-.499

DATA FOR PROJECT 6022 CONFIG. D WIND DIR. 146 TUBING NO. 1				
TAP	MEAN	RMS	MAX	MIN
1	-.771	.123	-.392	-1.368
2	-.726	.074	-.405	-1.053
3	-.688	.069	-.369	-.953
4	-.610	.081	-.227	-1.118
5	-.528	.086	-.238	-1.174
6	-.500	.097	-.176	-.999
7	-.478	.122	.004	-1.095
8	-.455	.150	.254	-1.012
9	-.422	.178	.391	-1.099
10	-.413	.210	.285	-1.299

DATA FOR PROJECT 6022 CONFIG. D WIND DIR. 160 TUBING NO. 1

TAP	MEAN	RMS	MAX	MIN	TAP	MEAN	RMS	MAX	MIN
1	.563	.037	.674	.431	11	-.625	.057	-.347	-.861
2	.431	.037	.564	.378	12	-.633	.056	-.347	-.867
3	.400	.020	.461	.332	13	-.634	.055	-.377	-.971
4	.314	.017	.367	.249	14	-.644	.059	-.362	-.926
5	.201	.015	.250	.147	15	-.626	.058	-.335	-.823
6	.082	.015	.137	-.021	16	-.587	.057	-.404	-.877
7	-.047	.016	.012	-.110	17	-.580	.056	-.403	-.820
8	-.153	.019	-.084	-.229	18	-.574	.055	-.396	-.806
9	-.245	.025	-.135	-.330	19	-.560	.051	-.395	-.791
10	-.381	.039	-.220	-.512	20	-.557	.053	-.364	-.805

DATA FOR PROJECT 6022 CONFIG. D WIND DIR. 161 TUBING NO. 1

TAP	MEAN	RMS	MAX	MIN	TAP	MEAN	RMS	MAX	MIN
1	-.453	.138	-.031	-1.008	11	-.207	.041	-.055	-.387
2	-.396	.106	-.032	-.911	12	-.213	.041	-.062	-.374
3	-.356	.094	-.041	-.839	13	-.218	.043	-.060	-.374
4	-.311	.093	-.003	-.715	14	-.232	.048	-.049	-.469
5	-.255	.107	-.233	-.675	15	-.250	.054	-.048	-.742
6	-.200	.145	-.415	-.664	16	-.280	.065	-.034	-.679
7	-.116	.149	-.441	-.609	17	-.334	.088	-.012	-.636
8	-.091	.148	-.453	-.594	18	-.400	.113	-.064	-.663
9	-.090	.138	-.414	-.555	19	-.494	.137	-.026	-1.342
10	-.123	.117	-.324	-.560	20	-.660	.201	-.040	-1.484

DATA FOR PROJECT 6022 CONFIG. E WIND DIR. 20 TUBING NO. 1

TAP	MEAN	RMS	MAX	MIN	TAP	MEAN	RMS	MAX	MIN
1	-.085	.023	.015	-.175	11	-.358	.025	-.260	-.443
2	.019	.020	.096	-.060	12	-.364	.026	-.265	-.453
3	.121	.018	.189	-.053	13	-.363	.024	-.269	-.446
4	.207	.017	.271	.147	14	-.367	.025	-.281	-.456
5	.297	.016	.360	.241	15	-.371	.025	-.276	-.496
6	.369	.017	.442	.310	16	-.380	.026	-.274	-.506
7	.451	.021	.520	.386	17	-.380	.026	-.281	-.508
8	.522	.027	.603	.410	18	-.381	.027	-.284	-.489
9	.605	.037	.711	.429	19	-.376	.029	-.267	-.473
10	.713	.069	.910	.442	20	-.379	.034	-.248	-.542

DATA FOR PROJECT 6022 CONFIG. E WIND DIR. 21 TUBING NO. 1

TAP	MEAN	RMS	MAX	MIN	TAP	MEAN	RMS	MAX	MIN
1	-.078	.055	.144	-.316	11	-.313	.091	-.031	-.733
2	-.020	.059	.205	-.243	12	-.360	.088	-.023	-.676
3	-.047	.064	.265	-.181	13	-.294	.082	-.000	-.896
4	-.094	.080	.400	-.199	14	-.295	.082	-.008	-.716
5	-.083	.107	.480	-.304	15	-.277	.068	-.066	-.502
6	-.031	.126	.487	-.410	16	-.271	.063	-.020	-.558
7	-.185	.110	.450	-.492	17	-.272	.053	-.000	-.529
8	-.244	.091	.273	-.555	18	-.274	.051	-.000	-.555
9	-.318	.068	-.086	-.529	19	-.254	.046	-.000	-.422
10	-.341	.068	-.040	-.647	20	-.243	.052	-.043	-.425

DATA FOR PROJECT 6022 CONFIG. E WIND DIR. 22 TUBING NO. 1

TAP	MEAN	RMS	MAX	MIN	TAP	MEAN	RMS	MAX	MIN
1	-.091	.038	.057	-.287	11	-.316	.181	.246	-1.959
2	-.059	.034	.065	-.201	12	-.305	.164	.193	-1.371
3	-.027	.032	.103	-.157	13	-.289	.140	.169	-1.158
4	.002	.034	.124	-.125	14	-.273	.121	.128	-.839
5	.034	.041	.189	-.120	15	-.240	.092	.101	-.644
6	.054	.056	.274	-.144	16	-.226	.080	.096	-.655
7	.069	.081	.377	-.231	17	-.210	.069	.020	-.586
8	.062	.096	.488	-.301	18	-.203	.065	.027	-.541
9	.049	.102	.429	-.385	19	-.200	.064	.052	-.703
10	.006	.113	.539	-.510	20	-.196	.065	.032	-.660

DATA FOR PROJECT 6022 CONFIG. E WIND DIR. 35 TUBING NO. 1

TAP	MEAN	RMS	MAX	MIN	TAP	MEAN	RMS	MAX	MIN
1	-.179	.028	.287	.087	11	-.499	.038	-.367	-.632
2	-.264	.026	.366	.180	12	-.498	.035	-.367	-.626
3	-.328	.024	.420	.239	13	-.497	.031	-.367	-.624
4	-.387	.024	.484	.296	14	-.501	.030	-.367	-.621
5	-.456	.025	.549	.382	15	-.503	.027	-.367	-.623
6	-.524	.029	.630	.411	16	-.501	.029	-.367	-.631
7	-.618	.039	.770	.500	17	-.494	.030	-.367	-.622
8	-.690	.057	.891	.472	18	-.491	.032	-.367	-.649
9	-.748	.083	.995	.447	19	-.491	.033	-.367	-.625
10	-.736	.133	1.088	.190	20	-.492	.035	-.367	-.626

DATA FOR PROJECT 6022 CONFIG. E WIND DIR. 36 TUBING NO. 1

TAP	MEAN	RMS	MAX	MIN	TAP	MEAN	RMS	MAX	MIN
1	1.000	0.000	0.000	0.000	11	0.474	0.094	1.134	-0.829
2	1.000	0.000	0.000	0.000	12	0.460	0.092	1.135	-0.847
3	1.000	0.000	0.000	0.000	13	0.461	0.087	1.159	-0.888
4	1.000	0.000	0.000	0.000	14	0.457	0.085	1.170	-0.828
5	1.000	0.000	0.000	0.000	15	0.454	0.069	1.203	-0.764
6	1.000	0.000	0.000	0.000	16	0.450	0.064	1.245	-0.740
7	1.000	0.000	0.000	0.000	17	0.443	0.057	1.214	-0.674
8	1.000	0.000	0.000	0.000	18	0.441	0.056	1.196	-0.660
9	1.000	0.000	0.000	0.000	19	0.442	0.057	1.238	-0.628
10	1.000	0.000	0.000	0.000	20	0.445	0.059	1.216	-0.656

DATA FOR PROJECT 6022 CONFIG. E WIND DIR. 37 TUBING NO. 1

TAP	MEAN	RMS	MAX	MIN	TAP	MEAN	RMS	MAX	MIN
1	1.000	0.000	0.000	0.000	11	0.307	0.114	0.000	-1.347
2	1.000	0.000	0.000	0.000	12	0.307	0.109	0.019	-1.314
3	1.000	0.000	0.000	0.000	13	0.307	0.094	0.024	-1.028
4	1.000	0.000	0.000	0.000	14	0.307	0.086	0.013	-0.960
5	1.000	0.000	0.000	0.000	15	0.307	0.074	0.059	-0.897
6	1.000	0.000	0.000	0.000	16	0.307	0.069	0.083	-0.684
7	1.000	0.000	0.000	0.000	17	0.307	0.064	0.096	-0.597
8	1.000	0.000	0.000	0.000	18	0.307	0.069	0.100	-0.767
9	1.000	0.000	0.000	0.000	19	0.307	0.072	0.031	-0.697
10	1.000	0.000	0.000	0.000	20	0.307	0.085	0.029	-0.799

DATA FOR PROJECT 6022 CONFIG. E WIND DIR. 60 TUBING NO. 1

TAP	MEAN	RMS	MAX	MIN	TAP	MEAN	RMS	MAX	MIN
1	0.447	0.054	0.324	-0.005	11	0.626	0.031	0.467	-0.753
2	0.399	0.047	0.443	-0.156	12	0.629	0.030	0.493	-0.727
3	0.399	0.040	0.560	-0.280	13	0.626	0.029	0.507	-0.713
4	0.393	0.039	0.644	-0.338	14	0.627	0.029	0.513	-0.724
5	0.383	0.040	0.769	-0.463	15	0.629	0.029	0.524	-0.715
6	0.371	0.048	0.905	-0.526	16	0.639	0.029	0.529	-0.732
7	0.359	0.069	0.989	-0.548	17	0.644	0.024	0.539	-0.727
8	0.344	0.089	1.080	-0.497	18	0.649	0.023	0.565	-0.741
9	0.326	0.108	1.036	-0.393	19	0.644	0.027	0.494	-0.734
10	0.333	0.145	0.936	-0.044	20	0.653	0.028	0.524	-0.753

DATA FOR PROJECT 6022 CONFIG. E WIND DIR. 61 TUBING NO. 1

TAP	MEAN	RMS	MAX	MIN	TAP	MEAN	RMS	MAX	MIN
1	0.342	0.216	0.615	-0.825	11	0.596	0.060	0.322	-0.800
2	0.391	0.201	0.582	-0.787	12	0.584	0.059	0.332	-0.788
3	0.372	0.171	0.432	-0.787	13	0.571	0.055	0.343	-0.751
4	0.333	0.122	0.092	-0.862	14	0.560	0.053	0.357	-0.730
5	0.385	0.073	0.378	-0.949	15	0.532	0.047	0.350	-0.708
6	0.329	0.061	0.530	-0.966	16	0.557	0.046	0.354	-0.709
7	0.318	0.057	0.485	-0.995	17	0.559	0.045	0.378	-0.688
8	0.305	0.059	0.481	-0.970	18	0.562	0.047	0.388	-0.730
9	0.385	0.057	0.479	-0.947	19	0.558	0.051	0.336	-0.724
10	0.372	0.065	0.449	-1.120	20	0.564	0.059	0.318	-0.771

DATA FOR PROJECT 6022 CONFIG. E WIND DIR. 62 TUBING NO. 1

TAP	MEAN	RMS	MAX	MIN	TAP	MEAN	RMS	MAX	MIN
1	0.345	0.046	0.169	-0.634	11	0.363	0.088	0.067	-1.028
2	0.342	0.046	0.169	-0.608	12	0.360	0.085	0.074	-1.094
3	0.335	0.048	0.147	-0.536	13	0.358	0.081	0.093	-1.333
4	0.334	0.049	0.132	-0.620	14	0.353	0.074	0.108	-0.945
5	0.336	0.051	0.144	-0.658	15	0.348	0.059	0.128	-0.667
6	0.340	0.053	0.086	-0.596	16	0.347	0.054	0.153	-0.584
7	0.344	0.062	0.010	-0.639	17	0.349	0.048	0.174	-0.586
8	0.348	0.070	0.010	-0.791	18	0.350	0.046	0.167	-0.594
9	0.349	0.079	0.076	-0.947	19	0.352	0.044	0.203	-0.599
10	0.356	0.101	0.388	-0.973	20	0.357	0.047	0.211	-0.675

DATA FOR PROJECT 6022 CONFIG. E WIND DIR. 90 TUBING NO. 1

TAP	MEAN	RMS	MAX	MIN	TAP	MEAN	RMS	MAX	MIN
1	0.289	0.083	0.573	0.004	11	0.808	0.054	0.561	-0.984
2	0.438	0.088	0.763	0.197	12	0.807	0.051	0.557	-0.980
3	0.535	0.058	0.807	0.311	13	0.816	0.046	0.623	-0.962
4	0.619	0.056	0.887	0.421	14	0.820	0.043	0.636	-0.981
5	0.688	0.054	0.909	0.510	15	0.835	0.037	0.692	-0.951
6	0.715	0.061	0.956	0.491	16	0.839	0.035	0.699	-0.964
7	0.669	0.070	0.943	0.420	17	0.839	0.038	0.720	-0.984
8	0.563	0.080	0.867	0.271	18	0.839	0.038	0.704	-0.998
9	0.376	0.093	0.692	0.021	19	0.823	0.041	0.689	-0.978
10	0.075	0.106	0.432	-0.381	20	0.822	0.045	0.665	-1.003

DATA FOR PROJECT 6022 CONFIG. E WIND DIR. 91 TUBING NO. 1

TAP	MEAN	RMS	MAX	MIN	TAP	MEAN	RMS	MAX	MIN
1	.318	.232	.669	-.946	11	-.636	.081	-.377	-.914
2	.433	.193	.459	-.911	12	-.624	.073	-.372	-.896
3	.539	.141	.282	-.944	13	-.620	.066	-.330	-.846
4	.741	.101	-.190	-.098	14	-.610	.057	-.331	-.791
5	.867	.072	-.598	-.164	15	-.608	.049	-.353	-.780
6	.888	.073	-.559	-.155	16	-.608	.052	-.361	-.789
7	.857	.074	-.536	-.135	17	-.614	.064	-.380	-.832
8	.868	.080	-.512	-.1084	18	-.611	.073	-.348	-.854
9	.769	.092	-.498	-.1106	19	-.609	.075	-.350	-.862
10	.735	.110	-.413	-.232	20	-.610	.083	-.338	-.890

DATA FOR PROJECT 6022 CONFIG. E WIND DIR. 92 TUBING NO. 1

TAP	MEAN	RMS	MAX	MIN	TAP	MEAN	RMS	MAX	MIN
1	-.382	.053	-.186	-.623	11	-.362	.077	-.080	-.716
2	-.384	.052	-.218	-.641	12	-.362	.071	-.105	-.657
3	-.397	.052	-.244	-.788	13	-.364	.064	-.077	-.595
4	-.412	.054	-.241	-.777	14	-.362	.058	-.091	-.572
5	-.423	.060	-.225	-.771	15	-.363	.052	-.133	-.563
6	-.423	.071	-.027	-.805	16	-.356	.048	-.159	-.532
7	-.410	.088	.106	-.769	17	-.344	.045	-.175	-.514
8	-.397	.109	.425	-.862	18	-.331	.045	-.148	-.517
9	-.394	.127	.331	-1.070	19	-.325	.045	-.190	-.502
10	-.392	.160	.569	-1.255	20	-.329	.047	-.153	-.484

DATA FOR PROJECT 6022 CONFIG. E WIND DIR. 120 TUBING NO. 1

TAP	MEAN	RMS	MAX	MIN	TAP	MEAN	RMS	MAX	MIN
1	.549	.192	.881	.245	11	-.862	.049	-.673	-1.057
2	.659	.077	.923	.408	12	-.866	.046	-.645	-1.052
3	.717	.061	.929	.524	13	-.860	.042	-.723	-1.019
4	.739	.054	.948	.565	14	-.870	.040	-.741	-1.015
5	.717	.045	.909	.566	15	-.870	.036	-.757	-.999
6	.622	.044	.767	.471	16	-.869	.036	-.743	-.994
7	.444	.043	.619	.281	17	-.868	.041	-.730	-1.005
8	.255	.046	.421	-.072	18	-.870	.044	-.729	-1.025
9	.047	.052	.209	-.115	19	-.864	.043	-.717	-1.029
10	-.262	.056	-.086	-.453	20	-.867	.049	-.700	-1.092

DATA FOR PROJECT 6022 CONFIG. E WIND DIR. 121 TUBING NO. 1

TAP	MEAN	RMS	MAX	MIN	TAP	MEAN	RMS	MAX	MIN
1	-.692	.151	-.113	-1.341	11	-.505	.105	-.204	-1.289
2	-.770	.111	-.361	-1.194	12	-.497	.085	-.234	-.792
3	-.841	.091	-.524	-1.197	13	-.490	.072	-.270	-.772
4	-.880	.093	-.558	-1.178	14	-.494	.061	-.303	-.708
5	-.860	.092	-.411	-1.129	15	-.498	.058	-.308	-.702
6	-.776	.105	-.278	-1.216	16	-.503	.067	-.289	-.761
7	-.691	.136	-.038	-1.574	17	-.498	.090	-.216	-.802
8	-.672	.196	.113	-1.530	18	-.500	.111	-.152	-.912
9	-.665	.253	.189	-1.885	19	-.502	.111	-.132	-.903
10	-.682	.332	.134	-2.141	20	-.511	.121	-.088	-1.058

DATA FOR PROJECT 6022 CONFIG. E WIND DIR. 122 TUBING NO. 1

TAP	MEAN	RMS	MAX	MIN	TAP	MEAN	RMS	MAX	MIN
1	-.330	.047	-.037	-.619	11	-.333	.050	-.151	-.553
2	-.332	.052	-.016	-.676	12	-.334	.046	-.169	-.525
3	-.330	.058	-.026	-.739	13	-.329	.043	-.201	-.505
4	-.326	.066	-.043	-.719	14	-.328	.039	-.219	-.492
5	-.311	.076	-.211	-.679	15	-.320	.035	-.194	-.484
6	-.290	.084	-.357	-.664	16	-.315	.032	-.195	-.438
7	-.265	.115	-.376	-.661	17	-.314	.031	-.178	-.440
8	-.253	.129	-.552	-.707	18	-.319	.031	-.176	-.468
9	-.244	.136	-.684	-.723	19	-.320	.030	-.187	-.486
10	-.258	.131	-.654	-.719	20	-.326	.031	-.195	-.476

DATA FOR PROJECT 6022 CONFIG. E WIND DIR. 145 TUBING NO. 1

TAP	MEAN	RMS	MAX	MIN	TAP	MEAN	RMS	MAX	MIN
1	.718	.073	.930	.485	11	-.666	.028	-.568	-.777
2	.705	.052	.864	.526	12	-.669	.026	-.579	-.763
3	.663	.037	.774	.512	13	-.669	.024	-.577	-.751
4	.591	.030	.691	.474	14	-.675	.025	-.585	-.769
5	.466	.023	.547	.383	15	-.669	.025	-.581	-.761
6	.320	.023	.416	.244	16	-.667	.026	-.581	-.777
7	.139	.021	.210	.054	17	-.657	.030	-.549	-.776
8	-.018	.022	.059	-.107	18	-.659	.032	-.544	-.779
9	-.162	.028	-.058	-.253	19	-.652	.030	-.536	-.769
10	-.368	.029	-.242	-.475	20	-.654	.034	-.534	-.819

DATA FOR PROJECT 6022 CONFIG. E WIND DIR. 146 TUBING NO. 1

TAP	MEAN	RMS	MAX	MIN	TAP	MEAN	RMS	MAX	MIN
1	.478	.139	.145	-1.136	11	-.331	.078	-.053	-.695
2	.491	.118	.069	-.886	12	-.332	.066	-.079	-.617
3	.495	.118	.038	-.950	13	-.334	.063	-.114	-.598
4	.495	.137	.121	-.919	14	-.351	.067	-.148	-.659
5	.334	.148	.279	-1.079	15	-.359	.075	-.131	-.774
6	.267	.199	.533	-1.060	16	-.367	.103	-.034	-.750
7	.241	.236	.574	-1.105	17	-.382	.157	.147	-.991
8	.243	.266	.701	-1.154	18	-.398	.188	.195	-1.142
9	.249	.277	.713	-1.168	19	-.408	.171	.149	-1.110
10	.266	.276	.738	-1.280	20	-.422	.183	.135	-1.166

DATA FOR PROJECT 6022 CONFIG. E WIND DIR. 147 TUBING NO. 1

TAP	MEAN	RMS	MAX	MIN	TAP	MEAN	RMS	MAX	MIN
1	-.244	.048	-.054	-.535	11	-.259	.027	-.166	-.413
2	-.240	.053	-.007	-.607	12	-.260	.025	-.172	-.396
3	-.232	.059	-.020	-.603	13	-.255	.023	-.186	-.348
4	-.223	.068	.151	-.574	14	-.255	.022	-.189	-.343
5	-.199	.081	.284	-.511	15	-.257	.020	-.192	-.328
6	-.169	.100	.452	-.582	16	-.263	.020	-.188	-.328
7	-.143	.108	.628	-.478	17	-.261	.022	-.187	-.322
8	-.143	.109	.518	-.468	18	-.263	.024	-.189	-.372
9	-.162	.105	.562	-.566	19	-.263	.026	-.182	-.396
10	-.190	.088	.413	-.570	20	-.268	.030	-.167	-.466

DATA FOR PROJECT 6022 CONFIG. E WIND DIR. 160 TUBING NO. 1

TAP	MEAN	RMS	MAX	MIN	TAP	MEAN	RMS	MAX	MIN
1	.573	.040	.696	.333	11	-.576	.057	-.261	-.902
2	.496	.028	.587	.352	12	-.582	.056	-.290	-.908
3	.419	.020	.489	.324	13	-.586	.058	-.357	-.814
4	.336	.017	.399	.277	14	-.589	.062	-.353	-.829
5	.283	.015	.298	.163	15	-.585	.065	-.333	-1.064
6	.199	.015	.159	-.050	16	-.582	.065	-.379	-1.011
7	.021	.016	.029	-.082	17	-.558	.059	-.371	-.943
8	-.126	.019	-.066	-.186	18	-.544	.055	-.358	-.803
9	-.219	.023	-.125	-.296	19	-.531	.049	-.363	-.737
10	-.344	.035	-.211	-.464	20	-.530	.052	-.341	-.729

DATA FOR PROJECT 6022 CONFIG. E WIND DIR. 161 TUBING NO. 1

TAP	MEAN	RMS	MAX	MIN	TAP	MEAN	RMS	MAX	MIN
1	-.083	.099	.273	-.555	11	-.276	.048	-.070	-.471
2	-.066	.085	.291	-.535	12	-.288	.050	-.087	-.497
3	-.051	.078	.312	-.594	13	-.288	.053	-.064	-.543
4	-.034	.087	.472	-.675	14	-.314	.060	-.060	-.787
5	-.019	.095	.561	-.417	15	-.344	.071	-.029	-.601
6	-.019	.120	.625	-.513	16	-.387	.099	-.018	-.768
7	-.039	.115	.506	-.497	17	-.443	.113	-.029	-.880
8	-.071	.110	.381	-.463	18	-.501	.136	-.002	-1.016
9	-.103	.106	.331	-.543	19	-.544	.142	-.040	-1.175
10	-.159	.088	.199	-.585	20	-.569	.156	-.092	-1.384

DATA FOR PROJECT 6022 CONFIG. E WIND DIR. 162 TUBING NO. 1

TAP	MEAN	RMS	MAX	MIN	TAP	MEAN	RMS	MAX	MIN
1	-.177	.051	.070	-.391	11	-.211	.018	-.139	-.284
2	-.169	.055	.148	-.387	12	-.213	.018	-.153	-.283
3	-.158	.060	.233	-.394	13	-.215	.017	-.164	-.272
4	-.149	.069	.322	-.412	14	-.216	.017	-.163	-.270
5	-.130	.071	.302	-.433	15	-.218	.017	-.165	-.281
6	-.120	.073	.284	-.416	16	-.223	.019	-.163	-.290
7	-.121	.067	.263	-.349	17	-.227	.024	-.145	-.327
8	-.135	.062	.173	-.345	18	-.232	.032	-.139	-.443
9	-.156	.057	.184	-.398	19	-.235	.037	-.134	-.492
10	-.173	.044	.075	-.475	20	-.241	.041	-.129	-.523

DATA FOR PROJECT 6022 CONFIG. F WIND DIR. 35 TUBING NO. 1

TAP	MEAN	RMS	MAX	MIN	TAP	MEAN	RMS	MAX	MIN
1	.046	.031	.151	-.054	11	-.439	.029	-.321	-.535
2	.171	.027	.275	.082	12	-.441	.027	-.335	-.538
3	.273	.025	.394	.194	13	-.439	.025	-.347	-.533
4	.349	.024	.454	.274	14	-.435	.025	-.351	-.536
5	.435	.023	.524	.362	15	-.445	.026	-.356	-.534
6	.508	.026	.608	.420	16	-.446	.027	-.342	-.537
7	.607	.035	.781	.486	17	-.437	.030	-.285	-.538
8	.688	.050	.892	.513	18	-.426	.032	-.305	-.536
9	.762	.071	1.003	.510	19	-.432	.035	-.227	-.541
10	.783	.115	1.111	.325	20	-.432	.038	-.228	-.545

DATA FOR PROJECT 6022 CONFIG. F WIND DIR. 36 TUBING NO. 1				
TAP	MEAN	RMS	MAX	MIN
1	120	087	168	411
2	658	129	408	492
3	621	111	447	382
4	648	112	459	304
5	626	139	537	416
6	694	196	700	707
7	214	129	438	650
8	303	114	631	677
9	371	092	374	645
10	557	104	194	983

DATA FOR PROJECT 6022 CONFIG. F WIND DIR. 37 TUBING NO. 1				
TAP	MEAN	RMS	MAX	MIN
1	180	038	008	419
2	169	037	015	413
3	167	038	007	336
4	164	039	009	349
5	160	046	030	395
6	156	053	054	404
7	158	066	074	521
8	157	073	122	630
9	159	083	173	621
10	171	112	328	964

DATA FOR PROJECT 6022 CONFIG. F WIND DIR. 60 TUBING NO. 1				
TAP	MEAN	RMS	MAX	MIN
1	134	053	333	000
2	682	046	453	151
3	404	041	590	284
4	500	040	671	381
5	611	040	793	473
6	708	049	946	509
7	786	067	1023	565
8	816	087	1112	466
9	751	102	1035	333
10	572	134	974	060

DATA FOR PROJECT 6022 CONFIG. F WIND DIR. 61 TUBING NO. 1				
TAP	MEAN	RMS	MAX	MIN
1	221	163	428	691
2	204	164	539	675
3	210	158	432	634
4	280	143	356	676
5	419	112	183	751
6	533	687	013	820
7	603	662	312	860
8	617	659	353	842
9	609	656	430	819
10	598	662	362	834

DATA FOR PROJECT 6022 CONFIG. F WIND DIR. 62 TUBING NO. 1				
TAP	MEAN	RMS	MAX	MIN
1	324	055	160	631
2	322	054	154	605
3	323	053	121	686
4	326	053	099	579
5	330	056	057	579
6	332	084	001	605
7	329	078	082	750
8	320	088	055	743
9	329	101	155	876
10	340	135	369	1207

DATA FOR PROJECT 6022 CONFIG. F WIND DIR. 120 TUBING NO. 1				
TAP	MEAN	RMS	MAX	MIN
1	575	098	885	279
2	674	074	928	425
3	724	058	959	534
4	737	049	938	559
5	702	042	862	573
6	606	041	748	481
7	438	038	578	319
8	262	041	400	102
9	071	046	247	152
10	211	047	044	386

DATA FOR PROJECT 6022 CONFIG. F WIND DIR. 121 TUBING NO. 1				
TAP	MEAN	RMS	MAX	MIN
1	-.492	.183	.143	-1.176
2	-.557	.141	.008	-1.087
3	-.613	.112	-.135	-.948
4	-.655	.103	-.224	-.985
5	-.687	.100	-.287	-.953
6	-.630	.109	-.243	-.930
7	-.563	.118	-.179	-1.445
8	-.533	.141	-.093	-1.925
9	-.520	.172	.164	-2.049
10	-.526	.196	.198	-2.005

DATA FOR PROJECT 6022 CONFIG. F WIND DIR. 122 TUBING NO. 1				
TAP	MEAN	RMS	MAX	MIN
1	-.273	.070	.199	-.719
2	-.272	.081	.239	-.614
3	-.268	.093	.295	-.594
4	-.260	.111	.413	-.651
5	-.261	.115	.718	-.652
6	-.240	.135	.634	-.739
7	-.218	.148	.615	-.778
8	-.207	.159	.722	-.772
9	-.207	.178	.788	-.836
10	-.219	.176	.701	-1.232

DATA FOR PROJECT 6022 CONFIG. F WIND DIR. 145 TUBING NO. 1				
TAP	MEAN	RMS	MAX	MIN
1	.723	.070	.924	.503
2	.699	.050	.852	.531
3	.652	.035	.765	.522
4	.578	.028	.675	.473
5	.459	.021	.538	.373
6	.313	.020	.379	.242
7	.140	.019	.203	.071
8	.009	.020	.063	-.075
9	.140	.023	.060	-.211
10	.328	.027	.225	-.423

DATA FOR PROJECT 6022 CONFIG. F WIND DIR. 146 TUBING NO. 1				
TAP	MEAN	RMS	MAX	MIN
1	-.330	.102	.063	-.898
2	-.327	.091	.039	-.767
3	-.313	.088	.073	-.669
4	-.295	.101	.175	-.936
5	-.260	.108	.220	-.841
6	-.247	.147	.520	-.762
7	-.235	.166	.615	-.756
8	-.233	.178	.640	-.888
9	-.235	.175	.479	-.988
10	-.258	.170	.539	-1.118

DATA FOR PROJECT 6022 CONFIG. F WIND DIR. 147 TUBING NO. 1				
TAP	MEAN	RMS	MAX	MIN
1	-.206	.069	.147	-.457
2	-.191	.078	.243	-.527
3	-.173	.087	.438	-.500
4	-.152	.100	.515	-.499
5	-.124	.107	.516	-.543
6	-.108	.116	.532	-.489
7	-.102	.116	.537	-.451
8	-.113	.113	.550	-.480
9	-.135	.107	.537	-.566
10	-.169	.089	.574	-.475

DATA FOR PROJECT 6022 CONFIG. G WIND DIR. 20 TUBING NO. 1				
TAP	MEAN	RMS	MAX	MIN
1	-.155	.063	.080	-.641
2	-.053	.056	.160	-.409
3	.048	.048	.202	-.130
4	.130	.049	.277	-.055
5	.201	.054	.358	.002
6	.273	.063	.470	.037
7	.343	.072	.615	.134
8	.399	.087	.724	.158
9	.442	.104	.814	.149
10	.481	.136	.960	.047

DATA FOR PROJECT 6022 CONFIG. F WIND DIR. 147 TUBING NO. 1				
TAP	MEAN	RMS	MAX	MIN
1	.206	.069	.147	-.457
2	.191	.078	.243	-.527
3	.173	.087	.438	-.500
4	.152	.100	.515	-.499
5	.124	.107	.516	-.543
6	.108	.116	.532	-.489
7	.102	.116	.537	-.451
8	.117	.113	.550	-.480
9	.135	.107	.537	-.566
10	.169	.089	.274	-.475

DATA FOR PROJECT 6022 CONFIG. G WIND DIR. 20 TUBING NO. 1				
TAP	MEAN	RMS	MAX	MIN
1	.155	.063	.080	-.641
2	.053	.056	.160	-.409
3	.048	.048	.202	-.130
4	.130	.049	.277	-.055
5	.201	.054	.358	-.002
6	.273	.063	.470	.037
7	.343	.072	.615	.134
8	.399	.087	.724	.158
9	.442	.104	.814	.149
10	.481	.136	.960	.047

DATA FOR PROJECT 6022 CONFIG. G WIND DIR. 35 TUBING NO. 1				
TAP	MEAN	RMS	MAX	MIN
1	.024	.051	.156	-.216
2	.094	.053	.284	-.081
3	.188	.057	.408	-.004
4	.260	.065	.533	.075
5	.322	.073	.661	.117
6	.385	.085	.784	.146
7	.445	.111	.837	.136
8	.476	.135	.949	.046
9	.472	.157	.999	-.069
10	.411	.184	1.017	-.245

DATA FOR PROJECT 6022 CONFIG. G WIND DIR. 60 TUBING NO. 1				
TAP	MEAN	RMS	MAX	MIN
1	.168	.066	.409	-.061
2	.270	.073	.561	.036
3	.338	.081	.671	.086
4	.396	.090	.777	.163
5	.442	.100	.845	.181
6	.478	.112	.910	.194
7	.484	.142	1.152	.038
8	.458	.159	1.223	.059
9	.379	.167	1.156	-.033
10	.207	.168	.950	-.231

DATA FOR PROJECT 6022 CONFIG. G WIND DIR. 90 TUBING NO. 1				
TAP	MEAN	RMS	MAX	MIN
1	.313	.096	.710	-.039
2	.405	.105	.886	.067
3	.441	.110	.944	.124
4	.489	.115	.985	.164
5	.533	.134	1.015	.223
6	.519	.142	1.060	.180
7	.436	.143	.978	.091
8	.352	.140	.882	-.003
9	.227	.129	.713	-.115
10	.020	.116	.459	-.298

DATA FOR PROJECT 6022 CONFIG. G WIND DIR. 120 TUBING NO. 1				
TAP	MEAN	RMS	MAX	MIN
1	.438	.121	.970	.071
2	.496	.123	1.014	.139
3	.499	.119	1.032	.160
4	.499	.116	1.061	.157
5	.469	.112	.864	.157
6	.408	.111	.817	.106
7	.284	.104	.701	-.021
8	.178	.096	.574	-.125
9	.059	.090	.418	-.202
10	.135	.073	.166	-.382

DATA FOR PROJECT 6022 CONFIG. G WIND DIR. 145 TUBING NO. 1				
TAP	MEAN	RMS	MAX	MIN
1	.474	.129	.980	-.159
2	.459	.122	.907	-.149
3	.395	.110	.837	-.141
4	.346	.099	.805	-.127
5	.276	.086	.625	-.020
6	.181	.078	.518	-.047
7	.047	.066	.322	-.152
8	-.049	.056	.183	-.234
9	-.146	.052	-.122	-.311
10	-.289	.050	-.110	-.461

DATA FOR PROJECT 6022 CONFIG. G WIND DIR. 160 TUBING NO. 1				
TAP	MEAN	RMS	MAX	MIN
1	.399	.105	.939	-.087
2	.347	.095	.844	-.083
3	.278	.084	.728	-.031
4	.228	.074	.620	-.023
5	.150	.056	.374	-.060
6	.067	.050	.277	-.078
7	-.045	.041	.148	-.188
8	-.116	.041	.060	-.247
9	-.193	.041	-.032	-.329
10	-.300	.049	-.122	-.481

DATA FOR PROJECT 6022 CONFIG. G WIND DIR. 11 TUBING NO. 1				
TAP	MEAN	RMS	MAX	MIN
1	-.129	.057	.052	-.410
2	-.056	.056	.152	-.268
3	-.002	.057	.206	-.226
4	.032	.057	.247	-.198
5	.046	.056	.269	-.159
6	.075	.061	.344	-.125
7	.129	.081	.488	-.116
8	.164	.107	.661	-.153
9	.241	.144	.814	-.162
10	.307	.203	1.003	-.240

DATA FOR PROJECT 6022 CONFIG. G WIND DIR. 12 TUBING NO. 1				
TAP	MEAN	RMS	MAX	MIN
1	-.191	.062	.005	-.467
2	-.146	.055	.060	-.375
3	-.112	.052	.101	-.321
4	-.092	.052	.086	-.326
5	-.086	.055	.114	-.328
6	-.071	.063	.162	-.322
7	-.045	.071	.213	-.439
8	-.020	.085	.282	-.492
9	.000	.099	.375	-.471
10	.046	.140	.586	-.572

DATA FOR PROJECT 6022 CONFIG. G WIND DIR. 13 TUBING NO. 1				
TAP	MEAN	RMS	MAX	MIN
1	-.214	.047	-.072	-.450
2	-.190	.043	-.059	-.358
3	-.167	.043	-.027	-.329
4	-.157	.045	-.012	-.308
5	-.152	.046	-.002	-.390
6	-.141	.051	.024	-.543
7	-.134	.056	.053	-.402
8	-.134	.066	.092	-.422
9	-.141	.070	.132	-.490
10	-.149	.086	.229	-.841

DATA FOR PROJECT 6022 CONFIG. G WIND DIR. 14 TUBING NO. 1				
TAP	MEAN	RMS	MAX	MIN
1	-.221	.042	-.096	-.388
2	-.201	.041	-.074	-.353
3	-.189	.037	-.057	-.304
4	-.181	.038	-.043	-.296
5	-.178	.038	-.036	-.318
6	-.169	.040	-.028	-.328
7	-.163	.048	-.010	-.417
8	-.167	.054	-.001	-.504
9	-.177	.057	-.005	-.792
10	-.187	.062	-.028	-.863

DATA FOR PROJECT 6022 CONFIG. G WIND DIR. 15 TUBING NO. 1				
TAP	MEAN	RMS	MAX	MIN
1	.155	.039	.039	-.293
2	.110	.038	.010	-.243
3	.072	.036	.056	-.185
4	.045	.036	.092	-.163
5	.028	.038	.095	-.149
6	.005	.039	.117	-.128
7	.009	.041	.149	-.156
8	.013	.043	.160	-.156
9	.002	.042	.145	-.172
10	.027	.044	.135	-.191

DATA FOR PROJECT 6022 CONFIG. G WIND DIR. 21 TUBING NO. 1				
TAP	MEAN	RMS	MAX	MIN
1	.150	.114	.696	-.131
2	.204	.117	.826	-.068
3	.224	.115	.840	-.036
4	.252	.118	.854	-.050
5	.253	.105	.710	-.000
6	.208	.097	.631	-.043
7	.108	.084	.477	-.111
8	.031	.072	.362	-.197
9	.053	.070	.286	-.272
10	.176	.060	.072	-.392

DATA FOR PROJECT 6022 CONFIG. G WIND DIR. 22 TUBING NO. 1				
TAP	MEAN	RMS	MAX	MIN
1	.063	.061	.296	-.306
2	.039	.064	.341	-.253
3	.029	.068	.377	-.250
4	.000	.080	.538	-.223
5	.030	.095	.649	-.236
6	.039	.103	.679	-.219
7	.008	.103	.519	-.287
8	.022	.097	.448	-.317
9	.063	.088	.279	-.306
10	.138	.075	.178	-.385

DATA FOR PROJECT 6022 CONFIG. G WIND DIR. 23 TUBING NO. 1				
TAP	MEAN	RMS	MAX	MIN
1	.141	.052	.017	-.383
2	.141	.054	.037	-.385
3	.150	.055	.032	-.395
4	.144	.059	.034	-.436
5	.143	.060	.153	-.373
6	.145	.072	.251	-.430
7	.157	.077	.266	-.449
8	.157	.079	.212	-.460
9	.166	.083	.400	-.576
10	.196	.073	.275	-.555

DATA FOR PROJECT 6022 CONFIG. G WIND DIR. 24 TUBING NO. 1				
TAP	MEAN	RMS	MAX	MIN
1	.172	.044	.023	-.342
2	.177	.046	.012	-.364
3	.189	.046	.035	-.380
4	.186	.049	.028	-.389
5	.192	.052	.000	-.429
6	.200	.059	.019	-.467
7	.215	.061	.015	-.501
8	.216	.062	.041	-.514
9	.218	.058	.080	-.472
10	.234	.057	.054	-.505

DATA FOR PROJECT 6022 CONFIG. G WIND DIR. 25 TUBING NO. 1				
TAP	MEAN	RMS	MAX	MIN
1	.014	.039	.122	-.142
2	.020	.040	.091	-.152
3	.030	.039	.065	-.170
4	.060	.040	.062	-.190
5	.084	.037	.056	-.245
6	.109	.039	.064	-.290
7	.148	.038	.035	-.345
8	.169	.037	.024	-.370
9	.197	.043	.023	-.493
10	.237	.042	.067	-.590

DATA FOR PROJECT 6022 CONFIG. H					WIND DIR. 20 TUBING NO. 1				
TAP	MEAN	RMS	MAX	MIN	TAP	MEAN	RMS	MAX	MIN
1	-.040	.062	.171	-.353	11	-.242	.079	-.002	-.670
2	-.022	.057	.235	-.246	12	-.257	.082	-.001	-.722
3	-.099	.050	.252	-.119	13	-.232	.082	.023	-.719
4	-.146	.052	.300	-.069	14	-.270	.087	.018	-.947
5	-.213	.055	.379	.016	15	-.273	.090	-.028	-1.249
6	-.254	.052	.459	.038	16	-.294	.095	-.014	-1.020
7	-.324	.073	.691	.092	17	-.284	.094	.003	-.949
8	-.354	.086	.839	.094	18	-.291	.094	.004	-.797
9	-.401	.100	.913	.113	19	-.272	.097	.086	-.683
10	-.432	.132	1.053	.048	20	-.280	.101	.165	-.718

DATA FOR PROJECT 6022 CONFIG. H					WIND DIR. 21 TUBING NO. 1				
TAP	MEAN	RMS	MAX	MIN	TAP	MEAN	RMS	MAX	MIN
1	-.037	.067	.289	-.241	11	-.248	.178	.279	-1.334
2	-.073	.059	.325	-.244	12	-.234	.161	.271	-1.335
3	-.123	.075	.452	-.159	13	-.209	.141	.279	-1.174
4	-.148	.089	.489	-.226	14	-.198	.131	.292	-.920
5	-.157	.120	.539	-.328	15	-.165	.107	.206	-1.187
6	-.079	.149	.576	-.378	16	-.159	.099	.241	-.832
7	-.025	.146	.765	-.536	17	-.138	.086	.178	-.686
8	-.103	.126	.509	-.617	18	-.137	.083	.197	-.662
9	-.137	.109	.462	-.638	19	-.122	.086	.263	-.756
10	-.187	.120	.308	-.502	20	-.124	.087	.204	-.726

DATA FOR PROJECT 6022 CONFIG. H					WIND DIR. 22 TUBING NO. 1				
TAP	MEAN	RMS	MAX	MIN	TAP	MEAN	RMS	MAX	MIN
1	-.002	.054	.269	-.217	11	-.242	.194	.258	-1.534
2	-.029	.050	.271	-.150	12	-.210	.166	.281	-1.348
3	-.045	.052	.254	-.123	13	-.187	.137	.358	-.985
4	-.066	.053	.289	-.101	14	-.154	.118	.345	-.939
5	-.078	.059	.320	-.159	15	-.136	.098	.296	-.605
6	-.089	.068	.366	-.171	16	-.114	.088	.246	-.540
7	-.071	.071	.386	-.172	17	-.102	.079	.203	-.472
8	-.054	.074	.421	-.187	18	-.084	.076	.194	-.409
9	-.026	.078	.420	-.407	19	-.089	.080	.268	-.363
10	-.006	.107	.489	-.757	20	-.084	.082	.253	-.597

DATA FOR PROJECT 6022 CONFIG. H					WIND DIR. 35 TUBING NO. 1				
TAP	MEAN	RMS	MAX	MIN	TAP	MEAN	RMS	MAX	MIN
1	-.024	.052	.219	-.139	11	-.382	.076	-.657	-.833
2	-.114	.055	.360	-.055	12	-.404	.075	-.648	-.907
3	-.215	.061	.558	-.028	13	-.387	.071	-.697	-.946
4	-.264	.068	.662	-.008	14	-.404	.071	-.168	-.817
5	-.336	.074	.656	.084	15	-.399	.066	-.196	-.668
6	-.376	.086	.713	.094	16	-.421	.067	-.150	-.697
7	-.430	.108	.810	.108	17	-.401	.064	-.200	-.653
8	-.438	.129	.963	.026	18	-.415	.065	-.208	-.690
9	-.448	.149	1.133	.013	19	-.392	.067	-.170	-.643
10	-.379	.180	1.245	-.175	20	-.415	.069	-.190	-.697

DATA FOR PROJECT 6022 CONFIG. H					WIND DIR. 36 TUBING NO. 1				
TAP	MEAN	RMS	MAX	MIN	TAP	MEAN	RMS	MAX	MIN
1	-.013	.123	.446	-.453	11	-.305	.124	.430	-1.099
2	-.035	.145	.435	-.503	12	-.314	.122	.347	-1.051
3	-.043	.184	.594	-.651	13	-.286	.114	.275	-1.007
4	-.040	.210	.581	-.655	14	-.293	.110	.242	-1.282
5	-.197	.194	.547	-.784	15	-.258	.092	.176	-.701
6	-.346	.135	.320	-.808	16	-.270	.087	.127	-.662
7	-.371	.094	.103	-.809	17	-.242	.079	.121	-.630
8	-.395	.090	.683	-.010	18	-.251	.078	.096	-.581
9	-.367	.087	.076	-.948	19	-.234	.078	.067	-.714
10	-.374	.095	.073	-.954	20	-.254	.085	.044	-1.285

DATA FOR PROJECT 6022 CONFIG. H					WIND DIR. 37 TUBING NO. 1				
TAP	MEAN	RMS	MAX	MIN	TAP	MEAN	RMS	MAX	MIN
1	-.035	.065	.212	-.333	11	-.207	.153	.231	-1.148
2	-.025	.067	.251	-.305	12	-.213	.141	.195	-1.282
3	-.004	.071	.361	-.219	13	-.186	.125	.206	-1.070
4	-.006	.075	.489	-.251	14	-.189	.116	.181	-.854
5	-.001	.072	.438	-.200	15	-.167	.106	.199	-.944
6	-.041	.071	.311	-.288	16	-.172	.100	.151	-.958
7	-.047	.082	.354	-.656	17	-.148	.089	.177	-.686
8	-.082	.093	.358	-.113	18	-.156	.088	.181	-.891
9	-.083	.101	.473	-.343	19	-.141	.094	.208	-1.051
10	-.127	.129	.391	-1.460	20	-.165	.105	.209	-1.002

DATA FOR PROJECT 6022 CONFIG. H WIND DIR. 145 TUBING NO. 1				
TAP	MEAN	RMS	MAX	MIN
1	.432	.120	.963	.143
2	.411	.109	.920	.140
3	.366	.100	.830	.113
4	.332	.091	.751	.097
5	.257	.083	.591	.027
6	.187	.075	.495	.016
7	.077	.064	.325	.012
8	.002	.056	.198	.017
9	.104	.053	.104	.072
10	.211	.053	.026	.391

DATA FOR PROJECT 6022 CONFIG. H WIND DIR. 146 TUBING NO. 1				
TAP	MEAN	RMS	MAX	MIN
1	-.382	.118	.040	-1.057
2	-.320	.093	.091	-.864
3	-.317	.092	.112	-.880
4	-.261	.102	.055	-.786
5	-.283	.097	.060	-.819
6	-.234	.109	.192	-.780
7	-.214	.137	.570	-.752
8	-.159	.155	.579	-.769
9	-.147	.156	.453	-.740
10	-.127	.154	.630	-.777

DATA FOR PROJECT 6022 CONFIG. H WIND DIR. 147 TUBING NO. 1				
TAP	MEAN	RMS	MAX	MIN
1	-.111	.049	.057	-.357
2	-.089	.049	.068	-.384
3	-.103	.051	.047	-.446
4	-.075	.055	.098	-.391
5	-.098	.064	.147	-.463
6	-.050	.076	.382	-.316
7	-.043	.089	.707	-.334
8	-.015	.089	.597	-.269
9	-.057	.086	.428	-.351
10	-.055	.074	.297	-.303

DATA FOR PROJECT 6022 CONFIG. H WIND DIR. 160 TUBING NO. 1				
TAP	MEAN	RMS	MAX	MIN
1	.361	.106	.787	.079
2	.307	.092	.668	.075
3	.262	.079	.574	.063
4	.214	.070	.497	.027
5	.140	.056	.342	-.024
6	.080	.051	.277	-.072
7	.014	.044	.201	-.119
8	-.044	.043	.128	-.166
9	-.092	.046	.076	-.243
10	-.165	.054	.031	-.401

DATA FOR PROJECT 6022 CONFIG. H WIND DIR. 161 TUBING NO. 1				
TAP	MEAN	RMS	MAX	MIN
1	-.166	.092	.097	-.735
2	-.134	.076	.104	-.642
3	-.113	.073	.252	-.403
4	-.077	.080	.309	-.513
5	-.046	.090	.461	-.361
6	-.018	.106	.475	-.428
7	-.010	.102	.487	-.433
8	-.017	.094	.339	-.510
9	-.036	.089	.344	-.407
10	-.069	.073	.211	-.345

DATA FOR PROJECT 6022 CONFIG. H WIND DIR. 162 TUBING NO. 1				
TAP	MEAN	RMS	MAX	MIN
1	-.091	.047	.111	-.302
2	-.081	.050	.125	-.323
3	-.080	.054	.146	-.329
4	-.058	.061	.235	-.338
5	-.039	.066	.310	-.311
6	-.017	.071	.340	-.293
7	-.024	.065	.273	-.238
8	-.027	.060	.215	-.232
9	-.049	.059	.238	-.298
10	-.067	.051	.151	-.279

DATA FOR PROJECT 6022 CONFIG. I WIND DIR. 20 TUBING NO. 1				
TAP	MEAN	RMS	MAX	MIN
1	.038	.061	.198	-.322
2	.032	.054	.257	-.208
3	.103	.053	.311	-.125
4	.161	.056	.383	-.035
5	.222	.060	.475	.006
6	.269	.067	.544	.036
7	.333	.080	.741	.065
8	.371	.093	.790	.085
9	.417	.108	.902	.105
10	.459	.141	1.058	.026

DATA FOR PROJECT 6022 CONFIG. I WIND DIR. 21 TUBING NO. 1				
TAP	MEAN	RMS	MAX	MIN
1	.009	.059	.259	-.302
2	.046	.059	.284	-.232
3	.091	.061	.340	-.152
4	.125	.066	.491	-.156
5	.167	.082	.553	-.187
6	.181	.108	.630	-.246
7	.162	.142	.748	-.244
8	.119	.151	.853	-.343
9	.076	.145	.827	-.403
10	.002	.151	.880	-.600

DATA FOR PROJECT 6022 CONFIG. I WIND DIR. 22 TUBING NO. 1				
TAP	MEAN	RMS	MAX	MIN
1	.011	.052	.201	-.196
2	.009	.049	.250	-.156
3	.033	.048	.227	-.149
4	.046	.048	.226	-.136
5	.067	.051	.247	-.146
6	.080	.058	.277	-.139
7	.085	.065	.363	-.202
8	.080	.073	.470	-.233
9	.076	.078	.485	-.239
10	.049	.107	.565	-.697

DATA FOR PROJECT 6022 CONFIG. I WIND DIR. 35 TUBING NO. 1				
TAP	MEAN	RMS	MAX	MIN
1	.079	.052	.265	-.112
2	.167	.055	.374	-.015
3	.242	.059	.458	.065
4	.305	.064	.546	.114
5	.363	.072	.624	.162
6	.411	.083	.717	.153
7	.452	.095	.781	.165
8	.478	.114	.847	.139
9	.491	.136	.922	.060
10	.453	.168	1.026	-.082

DATA FOR PROJECT 6022 CONFIG. I WIND DIR. 36 TUBING NO. 1				
TAP	MEAN	RMS	MAX	MIN
1	.063	.085	.436	-.296
2	.098	.095	.467	-.276
3	.125	.118	.598	-.283
4	.116	.132	.652	-.320
5	.029	.144	.547	-.423
6	.087	.136	.510	-.483
7	.148	.123	.431	-.753
8	.180	.104	.291	-.714
9	.192	.093	.217	-.727
10	.214	.101	.236	-.931

DATA FOR PROJECT 6022 CONFIG. I WIND DIR. 37 TUBING NO. 1				
TAP	MEAN	RMS	MAX	MIN
1	.006	.052	.202	-.238
2	.003	.050	.201	-.184
3	.011	.053	.283	-.374
4	.027	.054	.321	-.326
5	.029	.057	.308	-.228
6	.028	.063	.313	-.237
7	.027	.080	.546	-.361
8	.029	.087	.575	-.409
9	.021	.093	.537	-.755
10	.007	.120	.608	-1.399

DATA FOR PROJECT 6022 CONFIG. I					WIND DIR. 60 TUBING NO. 1				
TAP	MEAN	RMS	MAX	MIN	TAP	MEAN	RMS	MAX	MIN
1	.184	.075	.457	-.053	11	-.417	.060	-.230	-.779
2	.275	.082	.594	.034	12	-.416	.059	-.241	-.733
3	.345	.079	.727	.045	13	-.416	.057	-.235	-.687
4	.395	.086	.807	.140	14	-.420	.057	-.225	-.659
5	.441	.096	.924	.138	15	-.422	.060	-.226	-.625
6	.472	.111	1.064	.178	16	-.423	.061	-.228	-.619
7	.482	.134	1.098	.136	17	-.427	.060	-.213	-.622
8	.463	.150	1.037	.056	18	-.432	.061	-.212	-.625
9	.402	.160	1.006	-.018	19	-.425	.059	-.217	-.635
10	.250	.166	.851	-.222	20	-.427	.061	-.231	-.646

DATA FOR PROJECT 6022 CONFIG. I					WIND DIR. 61 TUBING NO. 1				
TAP	MEAN	RMS	MAX	MIN	TAP	MEAN	RMS	MAX	MIN
1	.093	.167	.648	-.437	11	-.303	.101	.049	-1.012
2	.084	.176	.647	-.465	12	-.293	.096	.046	-1.119
3	.043	.189	.615	-.488	13	-.286	.089	.038	-.760
4	.063	.187	.638	-.523	14	-.280	.083	.015	-.661
5	.233	.153	.546	-.638	15	-.263	.071	.035	-.588
6	.347	.115	.251	-.709	16	-.257	.068	-.019	-.593
7	.380	.100	.062	-1.293	17	-.257	.069	-.015	-.615
8	.377	.095	.156	-1.396	18	-.261	.072	-.022	-.732
9	.366	.093	.170	-1.096	19	-.256	.077	.012	-.607
10	.358	.104	.238	-1.270	20	-.260	.082	.036	-.617

DATA FOR PROJECT 6022 CONFIG. I					WIND DIR. 62 TUBING NO. 1				
TAP	MEAN	RMS	MAX	MIN	TAP	MEAN	RMS	MAX	MIN
1	-.082	.057	.117	-.332	11	-.134	.085	.127	-.855
2	-.078	.058	.129	-.308	12	-.133	.083	.094	-.961
3	-.068	.057	.134	-.367	13	-.131	.079	.090	-.808
4	-.064	.062	.158	-.349	14	-.131	.074	.115	-.526
5	-.066	.067	.199	-.555	15	-.128	.066	.134	-.832
6	-.068	.075	.236	-.788	16	-.123	.061	.121	-.729
7	-.062	.083	.348	-.354	17	-.125	.056	.113	-.618
8	-.059	.092	.447	-.413	18	-.130	.056	.109	-.550
9	-.059	.101	.471	-.460	19	-.131	.063	.062	-.555
10	-.066	.120	.602	-.654	20	-.134	.067	.063	-.787

DATA FOR PROJECT 6022 CONFIG. I					WIND DIR. 90 TUBING NO. 1				
TAP	MEAN	RMS	MAX	MIN	TAP	MEAN	RMS	MAX	MIN
1	.343	.097	.857	.037	11	-.421	.054	-.245	-.608
2	.426	.102	.976	.098	12	-.430	.053	-.238	-.609
3	.477	.106	.978	.183	13	-.439	.057	-.208	-.627
4	.510	.113	.998	.201	14	-.441	.056	-.227	-.632
5	.512	.117	1.003	.233	15	-.436	.054	-.245	-.621
6	.494	.125	1.120	.201	16	-.446	.055	-.251	-.643
7	.441	.127	1.014	.131	17	-.453	.059	-.252	-.673
8	.366	.130	.978	.053	18	-.451	.061	-.248	-.735
9	.278	.125	.794	-.099	19	-.436	.060	-.242	-.773
10	.090	.113	.564	-.258	20	-.449	.064	-.174	-.927

DATA FOR PROJECT 6022 CONFIG. I					WIND DIR. 91 TUBING NO. 1				
TAP	MEAN	RMS	MAX	MIN	TAP	MEAN	RMS	MAX	MIN
1	-.074	.184	.688	-.562	11	-.229	.085	.038	-.995
2	-.145	.162	.520	-.627	12	-.226	.078	-.012	-.839
3	-.238	.135	.307	-.644	13	-.226	.070	-.006	-.543
4	-.327	.112	.128	-.696	14	-.217	.064	-.001	-.492
5	-.388	.087	.030	-.660	15	-.211	.060	-.001	-.469
6	-.396	.082	.023	-.677	16	-.220	.066	.002	-.500
7	-.357	.084	.070	-.820	17	-.222	.074	.040	-.549
8	-.329	.093	.248	-1.208	18	-.217	.079	.056	-.583
9	-.320	.108	.135	-1.148	19	-.208	.079	.064	-.537
10	-.306	.127	.244	-1.474	20	-.217	.083	.058	-.550

DATA FOR PROJECT 6022 CONFIG. I					WIND DIR. 92 TUBING NO. 1				
TAP	MEAN	RMS	MAX	MIN	TAP	MEAN	RMS	MAX	MIN
1	-.038	.048	.119	-.253	11	-.064	.059	.116	-.404
2	-.052	.050	.151	-.282	12	-.065	.056	.112	-.440
3	-.055	.052	.169	-.319	13	-.069	.052	.172	-.358
4	-.053	.056	.223	-.296	14	-.062	.049	.175	-.282
5	-.052	.062	.195	-.388	15	-.058	.046	.185	-.224
6	-.035	.071	.388	-.438	16	-.063	.045	.176	-.225
7	-.015	.082	.408	-.459	17	-.073	.045	.080	-.220
8	-.003	.095	.668	-.413	18	-.070	.045	.080	-.231
9	-.006	.105	1.154	-.342	19	-.062	.045	.087	-.240
10	.012	.112	1.173	-.377	20	-.072	.048	.082	-.286

DATA FOR PROJECT 6022 CONFIG. I WIND DIR. 120 TUBING NO. 1

TAP	MEAN	RMS	MAX	MIN	TAP	MEAN	RMS	MAX	MIN
1	.395	.116	.866	-.036	11	-.464	.054	-.272	-.653
2	.449	.116	.920	-.090	12	-.472	.054	-.287	-.651
3	.471	.115	.921	-.170	13	-.469	.053	-.287	-.651
4	.469	.115	.945	-.154	14	-.470	.053	-.292	-.657
5	.457	.119	.953	-.161	15	-.472	.053	-.294	-.656
6	.400	.117	.856	-.070	16	-.479	.055	-.297	-.671
7	.305	.112	.713	-.029	17	-.474	.057	-.303	-.799
8	.198	.106	.640	-.122	18	-.472	.060	-.296	-.850
9	.091	.097	.544	-.168	19	-.471	.060	-.285	-.864
10	-.088	.081	.295	-.339	20	-.480	.068	-.277	-.960

DATA FOR PROJECT 6022 CONFIG. I WIND DIR. 121 TUBING NO. 1

TAP	MEAN	RMS	MAX	MIN	TAP	MEAN	RMS	MAX	MIN
1	-.179	.159	.452	-.698	11	-.238	.073	-.023	-.677
2	-.259	.126	.256	-.650	12	-.240	.067	-.044	-.697
3	-.334	.102	.135	-.693	13	-.233	.061	-.042	-.536
4	-.395	.091	.078	-.769	14	-.232	.057	-.040	-.450
5	-.407	.085	.062	-.743	15	-.236	.058	-.045	-.462
6	-.371	.090	.080	-.713	16	-.246	.067	-.014	-.502
7	-.316	.094	.180	-.885	17	-.238	.078	-.000	-.598
8	-.299	.105	.345	-1.099	18	-.237	.084	.007	-.687
9	-.276	.118	.142	-1.046	19	-.237	.084	.038	-.754
10	-.274	.133	.213	-1.220	20	-.244	.087	.055	-1.010

DATA FOR PROJECT 6022 CONFIG. I WIND DIR. 122 TUBING NO. 1

TAP	MEAN	RMS	MAX	MIN	TAP	MEAN	RMS	MAX	MIN
1	-.106	.047	.118	-.282	11	-.113	.047	.042	-.313
2	-.107	.050	.198	-.312	12	-.118	.046	.029	-.285
3	-.105	.053	.130	-.359	13	-.110	.044	.045	-.338
4	-.107	.057	.133	-.372	14	-.110	.043	.037	-.305
5	-.093	.061	.141	-.404	15	-.109	.040	.033	-.267
6	-.080	.072	.284	-.400	16	-.115	.040	.033	-.255
7	-.060	.087	.499	-.437	17	-.112	.040	.039	-.243
8	-.057	.099	.702	-.453	18	-.113	.041	.041	-.251
9	-.039	.103	.632	-.455	19	-.114	.039	.039	-.241
10	-.048	.102	.576	-.454	20	-.122	.041	.019	-.259

DATA FOR PROJECT 6022 CONFIG. I WIND DIR. 145 TUBING NO. 1

TAP	MEAN	RMS	MAX	MIN	TAP	MEAN	RMS	MAX	MIN
1	.486	.128	1.140	.208	11	-.351	.054	-.170	-.575
2	.458	.118	1.054	.194	12	-.359	.054	-.180	-.567
3	.428	.108	.916	.194	13	-.363	.056	-.186	-.559
4	.381	.099	.806	.148	14	-.371	.059	-.175	-.569
5	.313	.088	.639	.063	15	-.355	.059	-.154	-.598
6	.226	.080	.528	.030	16	-.356	.060	-.136	-.642
7	.133	.068	.431	-.023	17	-.350	.061	-.149	-.657
8	.043	.060	.313	-.122	18	-.350	.063	-.137	-.645
9	-.045	.056	.218	-.240	19	-.340	.060	-.144	-.592
10	-.174	.051	.009	-.384	20	-.345	.064	-.149	-.680

DATA FOR PROJECT 6022 CONFIG. I WIND DIR. 146 TUBING NO. 1

TAP	MEAN	RMS	MAX	MIN	TAP	MEAN	RMS	MAX	MIN
1	-.167	.121	.254	-.787	11	-.180	.059	-.001	-.457
2	-.166	.103	.193	-.791	12	-.186	.055	-.014	-.398
3	-.159	.097	.155	-.654	13	-.184	.052	-.013	-.425
4	-.142	.099	.221	-.569	14	-.194	.053	-.008	-.426
5	-.113	.104	.418	-.524	15	-.201	.059	-.009	-.474
6	-.093	.125	.483	-.597	16	-.210	.073	-.013	-.589
7	-.082	.143	.660	-.618	17	-.211	.098	.069	-.688
8	-.097	.157	.941	-.660	18	-.223	.114	.108	-.712
9	-.092	.158	.511	-.688	19	-.234	.115	.145	-.896
10	-.120	.148	.469	-.702	20	-.249	.121	.134	-.791

DATA FOR PROJECT 6022 CONFIG. I WIND DIR. 147 TUBING NO. 1

TAP	MEAN	RMS	MAX	MIN	TAP	MEAN	RMS	MAX	MIN
1	-.086	.048	.103	-.299	11	-.113	.039	.027	-.267
2	-.084	.050	.091	-.280	12	-.116	.039	.021	-.283
3	-.080	.052	.093	-.300	13	-.111	.039	.013	-.282
4	-.074	.056	.143	-.293	14	-.114	.040	.012	-.286
5	-.057	.064	.382	-.299	15	-.113	.039	.011	-.280
6	-.044	.075	.410	-.317	16	-.116	.040	.015	-.273
7	-.030	.082	.440	-.343	17	-.116	.037	.023	-.236
8	-.033	.083	.420	-.286	18	-.121	.039	.022	-.245
9	-.045	.074	.415	-.265	19	-.120	.039	.024	-.244
10	-.068	.065	.297	-.300	20	-.123	.041	.025	-.276

DATA FOR PROJECT 6022 CONFIG. I WIND DIR. 160 TUBING NO. 1

TAP	MEAN	RMS	MAX	MIN	TAP	MEAN	RMS	MAX	MIN
1	.386	.094	.744	.128	11	-.285	.082	-.003	-.704
2	.338	.081	.634	.101	12	-.294	.084	-.023	-.664
3	.289	.071	.554	.073	13	-.312	.090	-.004	-.805
4	.244	.063	.503	.040	14	-.325	.098	-.001	-.782
5	.184	.057	.494	.019	15	-.350	.109	-.009	-.854
6	.126	.051	.389	-.028	16	-.370	.118	-.024	-1.350
7	.054	.044	.263	-.085	17	-.366	.114	.032	-1.211
8	-.004	.041	.154	-.137	18	-.349	.107	-.059	-1.087
9	-.064	.044	.095	-.218	19	-.333	.097	-.065	-.900
10	-.136	.051	.019	-.347	20	-.325	.097	-.047	-.878

DATA FOR PROJECT 6022 CONFIG. I WIND DIR. 161 TUBING NO. 1

TAP	MEAN	RMS	MAX	MIN	TAP	MEAN	RMS	MAX	MIN
1	.021	.083	.339	-.322	11	-.105	.046	.075	-.366
2	.036	.072	.336	-.234	12	-.110	.048	.072	-.337
3	.041	.070	.330	-.258	13	-.116	.049	.101	-.309
4	.050	.078	.340	-.251	14	-.119	.052	.089	-.383
5	.059	.089	.426	-.265	15	-.137	.056	.078	-.329
6	.058	.088	.524	-.290	16	-.162	.066	.083	-.526
7	.040	.090	.509	-.336	17	-.204	.086	.067	-.518
8	.016	.085	.389	-.334	18	-.236	.107	.117	-.717
9	-.008	.079	.317	-.342	19	-.273	.117	.071	-.894
10	-.041	.064	.263	-.366	20	-.302	.136	.055	-1.166

DATA FOR PROJECT 6022 CONFIG. I WIND DIR. 162 TUBING NO. 1

TAP	MEAN	RMS	MAX	MIN	TAP	MEAN	RMS	MAX	MIN
1	-.032	.053	.191	-.259	11	-.054	.035	.070	-.180
2	-.017	.055	.203	-.225	12	-.055	.035	.071	-.175
3	-.013	.058	.254	-.256	13	-.056	.036	.075	-.169
4	-.001	.061	.336	-.252	14	-.050	.036	.084	-.164
5	.020	.065	.505	-.229	15	-.055	.036	.080	-.170
6	.031	.066	.512	-.242	16	-.057	.037	.077	-.185
7	.021	.060	.356	-.279	17	-.063	.039	.066	-.219
8	.009	.056	.306	-.326	18	-.059	.041	.064	-.229
9	-.009	.052	.257	-.366	19	-.069	.043	.057	-.249
10	-.023	.045	.182	-.347	20	-.070	.046	.067	-.279

DATA FOR PROJECT 6022 CONFIG. J WIND DIR. 35 TUBING NO. 1

TAP	MEAN	RMS	MAX	MIN	TAP	MEAN	RMS	MAX	MIN
1	.070	.051	.263	-.097	11	-.335	.075	-.100	-.666
2	.159	.054	.370	-.020	12	-.340	.072	-.117	-.671
3	.249	.059	.469	.066	13	-.336	.069	-.124	-.662
4	.304	.064	.538	.089	14	-.344	.069	-.113	-.686
5	.364	.071	.622	.131	15	-.340	.065	-.124	-.639
6	.410	.083	.709	.129	16	-.347	.066	-.117	-.639
7	.457	.111	.973	.154	17	-.340	.064	-.127	-.605
8	.477	.132	1.084	.100	18	-.342	.065	-.130	-.621
9	.482	.153	1.177	.074	19	-.332	.065	-.097	-.595
10	.426	.182	1.241	-.106	20	-.336	.067	-.103	-.643

DATA FOR PROJECT 6022 CONFIG. J WIND DIR. 36 TUBING NO. 1

TAP	MEAN	RMS	MAX	MIN	TAP	MEAN	RMS	MAX	MIN
1	-.002	.072	.338	-.317	11	-.236	.136	.150	-1.256
2	.041	.075	.360	-.248	12	-.233	.129	.135	-1.115
3	.089	.085	.479	-.193	13	-.227	.119	.112	-1.136
4	.119	.094	.485	-.192	14	-.224	.109	.102	-.896
5	.137	.108	.587	-.183	15	-.216	.095	.074	-.744
6	.120	.125	.669	-.224	16	-.209	.065	.036	-.625
7	.072	.140	.661	-.398	17	-.196	.074	.030	-.553
8	.025	.139	.608	-.505	18	-.195	.073	.034	-.637
9	-.018	.134	.724	-.599	19	-.188	.083	.044	-1.140
10	-.082	.136	.548	-1.134	20	-.191	.090	.090	-1.108

DATA FOR PROJECT 6022 CONFIG. J WIND DIR. 37 TUBING NO. 1

TAP	MEAN	RMS	MAX	MIN	TAP	MEAN	RMS	MAX	MIN
1	-.034	.054	.159	-.255	11	-.158	.130	.154	-1.353
2	-.022	.053	.184	-.227	12	-.155	.123	.177	-1.194
3	-.000	.054	.238	-.344	13	-.150	.112	.276	-1.056
4	.007	.055	.292	-.453	14	-.149	.104	.409	-.787
5	.014	.059	.330	-.521	15	-.136	.088	.099	-.571
6	.011	.063	.357	-.522	16	-.127	.081	.110	-.649
7	.026	.077	.397	-.520	17	-.115	.074	.138	-.683
8	.026	.085	.502	-.418	18	-.117	.073	.118	-.756
9	.026	.093	.589	-.471	19	-.116	.076	.143	-.960
10	.009	.118	.813	-.763	20	-.121	.086	.107	-.995

DATA FOR PROJECT 6022 CONFIG. J WIND DIR. 60 TUBING NO. 1				
TAP	MEAN	RMS	MAX	MIN
1	.178	.070	.459	-.042
2	.268	.076	.603	.034
3	.345	.079	.684	.126
4	.394	.087	.765	.143
5	.441	.096	.875	.147
6	.475	.115	.919	.162
7	.513	.134	1.147	.133
8	.493	.151	1.191	-.067
9	.450	.164	1.153	-.025
10	.309	.175	1.027	-.185

DATA FOR PROJECT 6022 CONFIG. J WIND DIR. 61 TUBING NO. 1				
TAP	MEAN	RMS	MAX	MIN
1	.030	.134	.598	-.384
2	.051	.144	.670	-.380
3	.080	.148	.594	-.366
4	.043	.154	.651	-.361
5	.033	.153	.552	-.494
6	.120	.145	.430	-.579
7	.173	.119	.338	-.868
8	.206	.111	.379	-1.035
9	.215	.101	.248	-.805
10	.239	.106	.368	-1.132

DATA FOR PROJECT 6022 CONFIG. J WIND DIR. 62 TUBING NO. 1				
TAP	MEAN	RMS	MAX	MIN
1	-.051	.056	.159	-.286
2	-.046	.056	.129	-.283
3	-.031	.057	.262	-.263
4	-.034	.059	.234	-.297
5	-.027	.064	.280	-.300
6	-.028	.071	.285	-.391
7	-.023	.086	.340	-.623
8	-.028	.094	.481	-.717
9	-.020	.099	.574	-.718
10	-.031	.117	.743	-.842

DATA FOR PROJECT 6022 CONFIG. J WIND DIR. 120 TUBING NO. 1				
TAP	MEAN	RMS	MAX	MIN
1	.431	.116	.908	.107
2	.474	.116	.956	.146
3	.486	.115	.928	.149
4	.480	.114	.921	.164
5	.451	.112	.955	.188
6	.355	.111	.880	.121
7	.298	.106	.743	.022
8	.199	.100	.635	-.077
9	.083	.091	.509	-.214
10	-.082	.075	.278	-.366

DATA FOR PROJECT 6022 CONFIG. J WIND DIR. 121 TUBING NO. 1				
TAP	MEAN	RMS	MAX	MIN
1	-.125	.145	.455	-.660
2	-.156	.120	.337	-.558
3	-.188	.103	.200	-.518
4	-.208	.094	.143	-.562
5	-.200	.089	.134	-.720
6	-.185	.094	.215	-.593
7	-.171	.104	.374	-.971
8	-.168	.112	.446	-.861
9	-.174	.119	.553	-.937
10	-.180	.125	.616	-.944

DATA FOR PROJECT 6022 CONFIG. J WIND DIR. 122 TUBING NO. 1				
TAP	MEAN	RMS	MAX	MIN
1	-.071	.046	.089	-.315
2	-.067	.051	.106	-.338
3	-.062	.055	.228	-.310
4	-.058	.061	.364	-.318
5	-.041	.073	.427	-.342
6	-.028	.083	.416	-.373
7	-.014	.094	.483	-.350
8	-.013	.099	.585	-.355
9	-.015	.096	.554	-.428
10	-.027	.090	.554	-.418

DATA FOR PROJECT 6022 CONFIG. J WIND DIR. 145 TUBING NO. 1

TAP	MEAN	RMS	MAX	MIN	TAP	MEAN	RMS	MAX	MIN
1	.451	.125	1.069	.143	11	-.372	.058	-.171	-.599
2	.431	.115	1.010	.146	12	-.371	.057	-.173	-.604
3	.395	.104	.922	.131	13	-.375	.057	-.164	-.563
4	.353	.095	.851	.105	14	-.373	.058	-.161	-.575
5	.293	.084	.617	.061	15	-.373	.058	-.184	-.625
6	.214	.076	.580	-.004	16	-.366	.061	-.160	-.644
7	.109	.064	.429	-.077	17	-.360	.063	-.141	-.661
8	-.022	.057	.294	-.134	18	-.354	.064	-.137	-.612
9	-.066	.054	.179	-.289	19	-.354	.061	-.148	-.615
10	-.183	.051	.004	-.427	20	-.350	.065	-.130	-.641

DATA FOR PROJECT 6022 CONFIG. J WIND DIR. 146 TUBING NO. 1

TAP	MEAN	RMS	MAX	MIN	TAP	MEAN	RMS	MAX	MIN
1	-.035	.088	.271	-.386	11	-.179	.047	.018	-.398
2	-.035	.079	.239	-.337	12	-.179	.045	.026	-.399
3	-.039	.075	.261	-.428	13	-.190	.044	.041	-.356
4	-.031	.079	.350	-.399	14	-.194	.045	.030	-.365
5	-.030	.091	.428	-.396	15	-.201	.048	.019	-.401
6	-.025	.107	.508	-.389	16	-.200	.055	.021	-.437
7	-.033	.118	.636	-.325	17	-.209	.071	.017	-.506
8	-.043	.121	.584	-.301	18	-.209	.081	.022	-.600
9	-.067	.119	.518	-.306	19	-.215	.082	.001	-.584
10	-.097	.105	.543	-.362	20	-.213	.084	.020	-.763

DATA FOR PROJECT 6022 CONFIG. J WIND DIR. 147 TUBING NO. 1

TAP	MEAN	RMS	MAX	MIN	TAP	MEAN	RMS	MAX	MIN
1	-.064	.055	.271	-.253	11	-.096	.038	.050	-.263
2	-.054	.059	.346	-.260	12	-.098	.038	.056	-.258
3	-.043	.062	.415	-.250	13	-.095	.038	.032	-.224
4	-.032	.068	.437	-.258	14	-.096	.038	.031	-.229
5	-.006	.077	.622	-.283	15	-.100	.037	.027	-.233
6	-.006	.085	.542	-.294	16	-.103	.038	.026	-.238
7	-.010	.086	.623	-.354	17	-.102	.040	.032	-.342
8	-.001	.084	.484	-.262	18	-.102	.042	.024	-.327
9	-.009	.080	.416	-.283	19	-.105	.043	.014	-.334
10	-.037	.069	.383	-.317	20	-.109	.046	.019	-.422

DATA FOR PROJECT 6022 CONFIG. K WIND DIR. 39 TUBING NO. 1

TAP	MEAN	RMS	MAX	MIN	TAP	MEAN	RMS	MAX	MIN
1	-.100	.051	.051	-.340	11	-.208	.088	.130	-.778
2	-.079	.048	.066	-.289	12	-.190	.087	.134	-.782
3	-.067	.043	.070	-.237	13	-.205	.082	.097	-.751
4	-.036	.043	.093	-.200	14	-.202	.079	.083	-.798
5	-.026	.042	.107	-.204	15	-.203	.067	.047	-.635
6	-.021	.044	.107	-.218	16	-.185	.061	.045	-.506
7	-.020	.052	.160	-.244	17	-.193	.055	.028	-.463
8	-.003	.056	.188	-.285	18	-.192	.058	.019	-.594
9	-.012	.059	.204	-.645	19	-.202	.068	.023	-.825
10	-.033	.073	.232	-.744	20	-.186	.077	.004	-1.245

DATA FOR PROJECT 6022 CONFIG. K WIND DIR. 36 TUBING NO. 1

TAP	MEAN	RMS	MAX	MIN	TAP	MEAN	RMS	MAX	MIN
1	-.087	.044	.057	-.229	11	-.183	.115	.126	-1.171
2	-.080	.043	.059	-.220	12	-.164	.106	.181	-1.038
3	-.075	.048	.119	-.255	13	-.168	.098	.222	-1.035
4	-.057	.050	.157	-.233	14	-.161	.090	.221	-1.110
5	-.056	.052	.146	-.200	15	-.163	.092	.249	-.809
6	-.068	.056	.140	-.372	16	-.146	.084	.218	-.817
7	-.087	.061	.169	-.428	17	-.146	.074	.153	-.746
8	-.087	.065	.161	-.569	18	-.143	.074	.137	-.938
9	-.095	.069	.189	-.815	19	-.151	.068	.050	-.531
10	-.121	.085	.265	-1.376	20	-.147	.077	.062	-.644

DATA FOR PROJECT 6022 CONFIG. K WIND DIR. 37 TUBING NO. 1

TAP	MEAN	RMS	MAX	MIN	TAP	MEAN	RMS	MAX	MIN
1	-.000	.051	.169	-.202	11	-.127	.138	.221	-1.323
2	-.008	.049	.177	-.169	12	-.110	.125	.234	-1.061
3	-.009	.052	.195	-.227	13	-.103	.109	.233	-.807
4	-.020	.053	.217	-.262	14	-.093	.101	.223	-.657
5	-.021	.055	.233	-.269	15	-.074	.081	.214	-.477
6	-.018	.059	.243	-.235	16	-.059	.074	.197	-.425
7	-.014	.070	.347	-.279	17	-.053	.068	.172	-.498
8	-.018	.075	.377	-.466	18	-.051	.067	.157	-.466
9	-.016	.082	.368	-.781	19	-.057	.071	.217	-.600
10	-.000	.105	.394	-.881	20	-.054	.078	.227	-.608

DATA FOR PROJECT 6022 CONFIG. K WIND DIR. 90 TUBING NO. 1				
TAP	MEAN	RMS	MAX	MIN
1	.051	.059	.259	-.197
2	.097	.054	.309	-.148
3	.112	.053	.326	-.116
4	.123	.056	.344	-.136
5	.129	.060	.446	-.149
6	.143	.075	.536	-.151
7	.169	.112	.826	-.089
8	.190	.158	.973	-.174
9	.191	.195	1.082	-.220
10	.121	.204	.930	-.392

DATA FOR PROJECT 6022 CONFIG. K WIND DIR. 91 TUBING NO. 1				
TAP	MEAN	RMS	MAX	MIN
1	-.095	.104	.307	-.377
2	-.130	.089	.182	-.403
3	-.193	.074	.131	-.420
4	-.246	.063	.009	-.474
5	-.297	.055	-.120	-.491
6	-.275	.058	-.054	-.456
7	-.243	.066	.063	-.686
8	-.237	.077	.179	-.738
9	-.231	.089	.155	-.863
10	-.222	.108	.351	-1.464

DATA FOR PROJECT 6022 CONFIG. K WIND DIR. 92 TUBING NO. 1				
TAP	MEAN	RMS	MAX	MIN
1	-.049	.046	.109	-.252
2	-.039	.048	.120	-.281
3	-.045	.050	.119	-.305
4	-.042	.054	.122	-.295
5	-.039	.057	.270	-.282
6	-.020	.066	.292	-.274
7	.001	.077	.429	-.252
8	.017	.089	.559	-.288
9	.018	.105	.612	-.515
10	.024	.113	.845	-.594

DATA FOR PROJECT 6022 CONFIG. K WIND DIR. 145 TUBING NO. 1				
TAP	MEAN	RMS	MAX	MIN
1	-.050	.050	.109	-.227
2	-.052	.050	.096	-.226
3	-.057	.049	.116	-.228
4	-.057	.052	.156	-.269
5	-.060	.056	.171	-.424
6	-.073	.068	.273	-.450
7	-.066	.076	.504	-.411
8	-.083	.081	.498	-.442
9	-.102	.078	.404	-.463
10	-.137	.071	.267	-.484

DATA FOR PROJECT 6022 CONFIG. K WIND DIR. 146 TUBING NO. 1				
TAP	MEAN	RMS	MAX	MIN
1	-.137	.050	.076	-.309
2	-.140	.051	.064	-.323
3	-.133	.053	.053	-.345
4	-.133	.060	.123	-.457
5	-.123	.061	.284	-.431
6	-.115	.074	.345	-.446
7	-.097	.082	.467	-.408
8	-.097	.085	.399	-.457
9	-.105	.080	.347	-.392
10	-.123	.072	.262	-.457

DATA FOR PROJECT 6022 CONFIG. K WIND DIR. 147 TUBING NO. 1				
TAP	MEAN	RMS	MAX	MIN
1	-.055	.044	.112	-.219
2	-.057	.048	.101	-.261
3	-.044	.050	.164	-.230
4	-.033	.057	.273	-.261
5	-.013	.071	.462	-.245
6	.003	.082	.642	-.241
7	.025	.086	.590	-.299
8	.022	.084	.573	-.291
9	.003	.078	.492	-.308
10	.022	.067	.375	-.323

DATA FOR PROJECT 6022 CONFIG. K WIND DIR. 160 TUBING NO. 1

TAP	MEAN	RMS	MAX	MIN	TAP	MEAN	RMS	MAX	MIN
1	-.113	.049	.033	-.342	11	-.141	.039	-.019	-.289
2	-.105	.048	.050	-.296	12	-.142	.038	-.027	-.273
3	-.115	.048	.054	-.322	13	-.147	.042	-.004	-.302
4	-.114	.050	.058	-.370	14	-.142	.041	-.006	-.293
5	-.116	.048	.046	-.372	15	-.151	.041	-.016	-.295
6	-.110	.055	.085	-.402	16	-.158	.041	-.031	-.292
7	-.118	.054	.097	-.425	17	-.170	.044	-.031	-.312
8	-.120	.055	.102	-.418	18	-.169	.046	-.011	-.358
9	-.132	.053	.106	-.516	19	-.174	.045	-.013	-.362
10	-.129	.051	.064	-.594	20	-.177	.046	.010	-.376

DATA FOR PROJECT 6022 CONFIG. K WIND DIR. 161 TUBING NO. 1

TAP	MEAN	RMS	MAX	MIN	TAP	MEAN	RMS	MAX	MIN
1	-.097	.051	.161	-.338	11	-.100	.040	.030	-.265
2	-.089	.052	.155	-.303	12	-.101	.040	.027	-.239
3	-.095	.054	.162	-.309	13	-.106	.039	.022	-.239
4	-.093	.057	.168	-.306	14	-.098	.039	.029	-.228
5	-.096	.059	.161	-.401	15	-.102	.038	.024	-.229
6	-.085	.063	.192	-.435	16	-.105	.038	.027	-.225
7	-.089	.061	.227	-.433	17	-.108	.041	.032	-.275
8	-.089	.060	.205	-.343	18	-.105	.044	.043	-.269
9	-.092	.057	.118	-.523	19	-.111	.045	.037	-.328
10	-.090	.053	.087	-.442	20	-.117	.047	.037	-.360

DATA FOR PROJECT 6022 CONFIG. K WIND DIR. 162 TUBING NO. 1

TAP	MEAN	RMS	MAX	MIN	TAP	MEAN	RMS	MAX	MIN
1	-.019	.056	.342	-.250	11	-.036	.038	.083	-.161
2	-.004	.060	.446	-.250	12	-.036	.038	.085	-.162
3	-.001	.064	.520	-.228	13	-.038	.039	.109	-.177
4	.012	.070	.504	-.206	14	-.032	.038	.108	-.175
5	.023	.070	.389	-.204	15	-.035	.038	.106	-.175
6	.032	.067	.368	-.189	16	-.037	.038	.112	-.173
7	.023	.061	.361	-.205	17	-.039	.039	.103	-.174
8	.013	.057	.240	-.220	18	-.033	.040	.108	-.185
9	-.000	.054	.346	-.220	19	-.036	.040	.100	-.195
10	-.011	.046	.221	-.220	20	-.043	.043	.101	-.264

DATA FOR PROJECT 6022 CONFIG. L WIND DIR. 35 TUBING NO. 1

TAP	MEAN	RMS	MAX	MIN	TAP	MEAN	RMS	MAX	MIN
1	-.089	.047	.081	-.296	11	-.175	.107	.113	-1.177
2	-.076	.045	.087	-.269	12	-.158	.102	.137	-.824
3	-.072	.044	.070	-.260	13	-.169	.095	.104	-.640
4	-.045	.044	.086	-.221	14	-.168	.090	.093	-.631
5	-.041	.045	.094	-.237	15	-.171	.079	.177	-.600
6	-.040	.049	.110	-.282	16	-.152	.069	.154	-.446
7	-.043	.061	.180	-.333	17	-.158	.062	.077	-.491
8	-.026	.070	.246	-.350	18	-.156	.065	.049	-.567
9	-.028	.075	.306	-.412	19	-.163	.069	.020	-.794
10	-.043	.107	.446	-.885	20	-.153	.084	.035	-1.155

DATA FOR PROJECT 6022 CONFIG. L WIND DIR. 36 TUBING NO. 1

TAP	MEAN	RMS	MAX	MIN	TAP	MEAN	RMS	MAX	MIN
1	-.067	.046	.077	-.347	11	-.174	.130	.209	-1.169
2	-.061	.044	.096	-.297	12	-.152	.121	.214	-1.174
3	-.064	.045	.099	-.321	13	-.154	.110	.172	-.053
4	-.046	.046	.123	-.270	14	-.144	.101	.167	-.858
5	-.045	.049	.129	-.281	15	-.138	.091	.119	-.788
6	-.046	.054	.160	-.300	16	-.116	.072	.092	-.669
7	-.052	.059	.172	-.364	17	-.114	.064	.047	-.455
8	-.039	.064	.221	-.399	18	-.115	.063	.062	-.428
9	-.044	.069	.264	-.531	19	-.121	.071	.060	-.579
10	-.068	.095	.355	-.942	20	-.113	.080	.069	-.673

DATA FOR PROJECT 6022 CONFIG. L WIND DIR. 37 TUBING NO. 1

TAP	MEAN	RMS	MAX	MIN	TAP	MEAN	RMS	MAX	MIN
1	.006	.048	.153	-.234	11	-.116	.123	.227	-.939
2	.013	.047	.187	-.167	12	-.100	.116	.251	-.945
3	.016	.047	.231	-.205	13	-.099	.106	.214	-.750
4	.029	.048	.257	-.222	14	-.091	.098	.204	-.765
5	.030	.049	.272	-.260	15	-.064	.087	.175	-.724
6	.027	.054	.286	-.186	16	-.067	.080	.181	-.682
7	.027	.067	.276	-.435	17	-.060	.070	.172	-.395
8	.032	.070	.317	-.389	18	-.060	.071	.204	-.540
9	.030	.075	.356	-.399	19	-.058	.069	.166	-.503
10	.009	.101	.494	-.993	20	-.054	.078	.164	-.785

DATA FOR PROJECT 6022 CONFIG. L WIND DIR. 90 TUBING NO. 1				
TAP	MEAN	RMS	MAX	MIN
1	.003	.059	.192	-.282
2	.038	.056	.250	-.287
3	.044	.056	.256	-.269
4	.057	.060	.282	-.302
5	.064	.064	.308	-.228
6	.087	.078	.487	-.231
7	.106	.103	.689	-.235
8	.121	.135	.897	-.202
9	.100	.161	.928	-.313
10	.057	.168	.940	-.353

DATA FOR PROJECT 6022 CONFIG. L WIND DIR. 91 TUBING NO. 1				
TAP	MEAN	RMS	MAX	MIN
1	.115	.069	.287	-.313
2	.128	.062	.211	-.315
3	.160	.055	.071	-.325
4	.181	.050	.036	-.356
5	.195	.049	.013	-.436
6	.177	.056	.016	-.637
7	.173	.066	.061	-.686
8	.174	.077	.205	-.606
9	.180	.093	.401	-.643
10	.165	.108	.501	-.814

DATA FOR PROJECT 6022 CONFIG. L WIND DIR. 92 TUBING NO. 1				
TAP	MEAN	RMS	MAX	MIN
1	.042	.044	.114	-.214
2	.031	.045	.132	-.224
3	.036	.047	.128	-.227
4	.034	.051	.140	-.288
5	.030	.057	.205	-.399
6	.014	.065	.288	-.480
7	.012	.077	.495	-.475
8	.026	.090	.737	-.414
9	.036	.106	.751	-.292
10	.036	.111	.831	-.334

DATA FOR PROJECT 6022 CONFIG. L WIND DIR. 145 TUBING NO. 1				
TAP	MEAN	RMS	MAX	MIN
1	.051	.053	.136	-.338
2	.054	.053	.133	-.357
3	.047	.054	.158	-.297
4	.049	.059	.203	-.286
5	.044	.067	.373	-.315
6	.047	.081	.677	-.364
7	.036	.087	.612	-.496
8	.047	.089	.530	-.488
9	.060	.092	.551	-.361
10	.093	.080	.489	-.394

DATA FOR PROJECT 6022 CONFIG. L WIND DIR. 146 TUBING NO. 1				
TAP	MEAN	RMS	MAX	MIN
1	.118	.053	.082	-.418
2	.117	.055	.118	-.391
3	.110	.058	.144	-.384
4	.104	.063	.169	-.415
5	.095	.067	.301	-.395
6	.084	.080	.327	-.401
7	.064	.086	.391	-.342
8	.064	.088	.465	-.348
9	.076	.083	.363	-.352
10	.099	.073	.252	-.360

DATA FOR PROJECT 6022 CONFIG. L WIND DIR. 147 TUBING NO. 1				
TAP	MEAN	RMS	MAX	MIN
1	.047	.044	.122	-.236
2	.049	.047	.149	-.292
3	.039	.050	.173	-.343
4	.030	.056	.251	-.390
5	.006	.063	.355	-.217
6	.008	.073	.476	-.198
7	.029	.076	.510	-.167
8	.023	.076	.537	-.173
9	.020	.077	.587	-.207
10	.007	.064	.396	-.245

DATA FOR PROJECT 6022 CONFIG. L WIND DIR. 160 TUBING NO. 1

TAP	MEAN	RMS	MAX	MIN	TAP	MEAN	RMS	MAX	MIN
1	.089	.051	.068	.381	11	.108	.041	.023	.266
2	.082	.052	.110	.381	12	.110	.041	.027	.256
3	.090	.054	.131	.416	13	.115	.038	.019	.253
4	.092	.058	.183	.390	14	.109	.038	.022	.243
5	.089	.063	.317	.430	15	.116	.037	.020	.243
6	.083	.066	.396	.438	16	.122	.039	.007	.273
7	.086	.066	.352	.468	17	.129	.043	.016	.279
8	.088	.064	.333	.386	18	.127	.047	.019	.317
9	.097	.060	.232	.420	19	.132	.046	.027	.299
10	.097	.055	.120	.408	20	.135	.047	.027	.333

DATA FOR PROJECT 6022 CONFIG. L WIND DIR. 161 TUBING NO. 1

TAP	MEAN	RMS	MAX	MIN	TAP	MEAN	RMS	MAX	MIN
1	.074	.054	.158	.584	11	.079	.039	.053	.229
2	.063	.055	.182	.370	12	.079	.039	.054	.218
3	.070	.057	.197	.314	13	.081	.039	.065	.222
4	.065	.061	.343	.315	14	.071	.039	.073	.214
5	.054	.066	.395	.518	15	.078	.038	.063	.209
6	.040	.067	.412	.424	16	.080	.039	.070	.208
7	.046	.064	.358	.261	17	.086	.041	.049	.264
8	.049	.061	.355	.335	18	.081	.044	.050	.302
9	.061	.058	.352	.314	19	.088	.047	.046	.334
10	.060	.052	.246	.353	20	.095	.050	.040	.369

DATA FOR PROJECT 6022 CONFIG. L WIND DIR. 162 TUBING NO. 1

TAP	MEAN	RMS	MAX	MIN	TAP	MEAN	RMS	MAX	MIN
1	.008	.053	.332	.212	11	.030	.038	.114	.166
2	.009	.057	.374	.207	12	.029	.038	.112	.174
3	.010	.060	.367	.183	13	.034	.036	.073	.148
4	.022	.065	.467	.222	14	.029	.036	.078	.142
5	.032	.067	.483	.195	15	.030	.036	.074	.143
6	.039	.065	.419	.170	16	.033	.036	.075	.150
7	.028	.060	.337	.209	17	.035	.039	.107	.168
8	.018	.056	.273	.232	18	.029	.040	.119	.176
9	.010	.055	.278	.205	19	.033	.040	.114	.206
10	.002	.047	.198	.180	20	.039	.043	.106	.242

DATA FOR PROJECT 6022 CONFIG. M WIND DIR. 35 TUBING NO. 1

TAP	MEAN	RMS	MAX	MIN	TAP	MEAN	RMS	MAX	MIN
1	.036	.050	.142	.312	11	.139	.117	.158	.164
2	.027	.048	.165	.285	12	.117	.108	.195	.770
3	.028	.050	.270	.207	13	.126	.099	.184	.720
4	.006	.050	.272	.197	14	.118	.093	.162	.768
5	.010	.052	.239	.230	15	.116	.082	.125	.891
6	.012	.057	.259	.265	16	.092	.072	.128	.558
7	.017	.063	.303	.312	17	.092	.062	.115	.436
8	.002	.069	.349	.324	18	.089	.059	.115	.428
9	.006	.076	.383	.374	19	.098	.066	.168	.437
10	.004	.104	.549	.642	20	.082	.072	.165	.461

DATA FOR PROJECT 6022 CONFIG. M WIND DIR. 36 TUBING NO. 1

TAP	MEAN	RMS	MAX	MIN	TAP	MEAN	RMS	MAX	MIN
1	.017	.049	.188	.274	11	.133	.116	.192	.611
2	.008	.047	.190	.263	12	.113	.108	.204	.887
3	.011	.047	.182	.205	13	.118	.100	.208	.792
4	.009	.048	.166	.249	14	.111	.096	.213	.729
5	.010	.050	.178	.382	15	.105	.081	.152	.535
6	.009	.056	.220	.518	16	.081	.073	.220	.535
7	.005	.056	.261	.651	17	.078	.067	.188	.534
8	.018	.071	.322	.553	18	.077	.067	.176	.534
9	.015	.076	.355	.667	19	.083	.071	.162	.463
10	.007	.106	.518	.262	20	.072	.078	.177	.485

DATA FOR PROJECT 6022 CONFIG. M WIND DIR. 37 TUBING NO. 1

TAP	MEAN	RMS	MAX	MIN	TAP	MEAN	RMS	MAX	MIN
1	.017	.057	.240	.263	11	.122	.132	.171	.261
2	.028	.056	.310	.613	12	.104	.119	.207	.240
3	.035	.056	.326	.201	13	.103	.109	.165	.838
4	.050	.057	.369	.195	14	.095	.102	.193	.730
5	.055	.060	.439	.165	15	.077	.083	.184	.856
6	.052	.065	.540	.179	16	.058	.075	.176	.640
7	.047	.075	.477	.332	17	.054	.070	.158	.560
8	.053	.080	.477	.377	18	.052	.071	.166	.550
9	.052	.085	.550	.459	19	.062	.083	.240	.589
10	.031	.109	.644	.687	20	.056	.092	.247	.751

DATA FOR PROJECT 6022 CONFIG. M WIND DIR. 90 TUBING NO. 1				
TAP	MEAN	RMS	MAX	MIN
1	.022	.061	.215	-.271
2	.021	.062	.242	-.227
3	.026	.064	.282	-.230
4	.045	.070	.322	-.239
5	.062	.077	.469	-.247
6	.098	.092	.627	-.185
7	.116	.113	.844	-.190
8	.127	.133	.872	-.225
9	.115	.160	.931	-.349
10	.085	.161	.900	-.341

DATA FOR PROJECT 6022 CONFIG. M WIND DIR. 91 TUBING NO. 1				
TAP	MEAN	RMS	MAX	MIN
1	.090	.058	.174	-.470
2	.085	.055	.129	-.695
3	.099	.052	.081	-.405
4	.102	.053	.060	-.356
5	.110	.058	.081	-.554
6	.105	.066	.132	-.527
7	.106	.075	.327	-.538
8	.098	.086	.374	-.495
9	.093	.108	.632	-.710
10	.070	.127	.713	-1.020

DATA FOR PROJECT 6022 CONFIG. M WIND DIR. 92 TUBING NO. 1				
TAP	MEAN	RMS	MAX	MIN
1	.035	.045	.162	-.247
2	.023	.047	.171	-.238
3	.026	.049	.185	-.240
4	.022	.052	.199	-.356
5	.020	.057	.245	-.323
6	.002	.065	.439	-.255
7	.027	.079	.558	-.410
8	.043	.095	.634	-.403
9	.051	.107	.753	-.326
10	.058	.115	.841	-.329

DATA FOR PROJECT 6022 CONFIG. M WIND DIR. 145 TUBING NO. 1				
TAP	MEAN	RMS	MAX	MIN
1	.012	.072	.563	-.286
2	.003	.075	.579	-.276
3	.012	.078	.547	-.280
4	.021	.086	.636	-.253
5	.033	.088	.658	-.220
6	.029	.094	.565	-.296
7	.031	.090	.599	-.225
8	.011	.087	.526	-.256
9	.003	.093	.540	-.299
10	.043	.078	.433	-.378

DATA FOR PROJECT 6022 CONFIG. M WIND DIR. 146 TUBING NO. 1				
TAP	MEAN	RMS	MAX	MIN
1	.103	.051	.061	-.309
2	.101	.055	.072	-.330
3	.093	.058	.093	-.322
4	.084	.063	.113	-.338
5	.068	.072	.360	-.335
6	.046	.084	.408	-.357
7	.022	.093	.586	-.319
8	.021	.095	.844	-.344
9	.042	.080	.406	-.356
10	.065	.069	.280	-.326

DATA FOR PROJECT 6022 CONFIG. M WIND DIR. 147 TUBING NO. 1				
TAP	MEAN	RMS	MAX	MIN
1	.028	.045	.165	-.193
2	.027	.048	.136	-.224
3	.014	.050	.204	-.283
4	.001	.056	.307	-.234
5	.019	.065	.459	-.259
6	.036	.076	.583	-.272
7	.052	.080	.589	-.174
8	.051	.079	.532	-.177
9	.041	.074	.489	-.216
10	.018	.062	.375	-.258

DATA FOR PROJECT 6022 CONFIG. M WIND DIR. 160 TUBING NO. 1				
TAP	MEAN	RMS	MAX	MIN
1	-.036	.065	.446	-.266
2	-.025	.066	.336	-.260
3	-.029	.067	.307	-.266
4	-.025	.071	.340	-.270
5	-.027	.073	.496	-.319
6	-.018	.074	.458	-.307
7	-.026	.069	.376	-.279
8	-.032	.065	.384	-.259
9	-.042	.058	.264	-.249
10	-.048	.051	.169	-.317

DATA FOR PROJECT 6022 CONFIG. M WIND DIR. 161 TUBING NO. 1				
TAP	MEAN	RMS	MAX	MIN
1	-.033	.063	.305	-.296
2	-.018	.066	.417	-.264
3	-.017	.068	.356	-.257
4	-.008	.072	.387	-.304
5	-.004	.073	.394	-.234
6	-.013	.073	.380	-.230
7	-.006	.058	.379	-.215
8	-.004	.063	.304	-.204
9	-.019	.055	.321	-.293
10	-.027	.048	.201	-.230

DATA FOR PROJECT 6022 CONFIG. M WIND DIR. 162 TUBING NO. 1				
TAP	MEAN	RMS	MAX	MIN
1	.010	.055	.275	-.209
2	.027	.057	.314	-.162
3	.033	.061	.395	-.197
4	.048	.069	.676	-.179
5	.059	.067	.505	-.164
6	.067	.066	.469	-.136
7	.053	.060	.411	-.123
8	.042	.056	.345	-.163
9	.028	.052	.281	-.135
10	.015	.044	.226	-.136

DATA FOR PROJECT 6022 CONFIG. M WIND DIR. 11 TUBING NO. 1				
TAP	MEAN	RMS	MAX	MIN
1	.006	.069	.229	-.332
2	.039	.065	.285	-.237
3	.071	.062	.321	-.176
4	.075	.062	.319	-.139
5	.100	.062	.335	-.130
6	.094	.069	.347	-.176
7	.113	.088	.545	-.457
8	.129	.108	.711	-.254
9	.194	.126	.724	-.229
10	.238	.180	1.094	-.384

DATA FOR PROJECT 6022 CONFIG. M WIND DIR. 12 TUBING NO. 1				
TAP	MEAN	RMS	MAX	MIN
1	-.109	.058	.101	-.382
2	-.111	.058	.099	-.387
3	-.120	.056	.076	-.354
4	-.137	.059	.092	-.453
5	-.130	.061	.150	-.460
6	-.160	.069	.106	-.708
7	-.173	.077	.086	-.551
8	-.192	.087	.085	-.644
9	-.165	.103	.143	-.750
10	-.226	.190	.316	-1.247

DATA FOR PROJECT 6022 CONFIG. M WIND DIR. 13 TUBING NO. 1				
TAP	MEAN	RMS	MAX	MIN
1	-.264	.072	-.062	-.661
2	-.289	.070	-.065	-.673
3	-.288	.061	-.058	-.573
4	-.294	.058	-.068	-.561
5	-.266	.053	-.049	-.524
6	-.277	.052	-.042	-.506
7	-.276	.059	-.094	-.750
8	-.288	.067	-.085	-.822
9	-.264	.074	-.059	-.860
10	-.291	.090	-.028	-1.151

DATA FOR PROJECT 6022 CONFIG. M WIND DIR. 161 TUBING NO. 1				
TAP	MEAN	RMS	MAX	MIN
11	-.050	.039	.089	-.192
12	-.052	.039	.093	-.190
13	-.055	.039	.111	-.198
14	-.046	.039	.117	-.190
15	-.052	.038	.105	-.182
16	-.053	.039	.097	-.190
17	-.056	.038	.105	-.196
18	-.051	.041	.114	-.210
19	-.058	.044	.089	-.375
20	-.064	.049	.080	-.394

DATA FOR PROJECT 6022 CONFIG. N WIND DIR. 14 TUBING NO. 1				
TAP	MEAN	RMS	MAX	MIN
1	-.341	.066	-.146	-.889
2	-.346	.066	-.147	-.681
3	-.352	.069	-.191	-.757
4	-.355	.065	-.175	-.720
5	-.329	.057	-.175	-.583
6	-.335	.055	-.177	-.605
7	-.334	.050	-.175	-.548
8	-.339	.052	-.175	-.586
9	-.312	.053	-.149	-.573
10	-.332	.060	-.161	-.648

DATA FOR PROJECT 6022 CONFIG. N WIND DIR. 15 TUBING NO. 1				
TAP	MEAN	RMS	MAX	MIN
1	-.383	.063	-.194	-.858
2	-.390	.063	-.210	-.949
3	-.391	.061	-.236	-.756
4	-.393	.056	-.228	-.701
5	-.371	.049	-.207	-.620
6	-.378	.047	-.217	-.593
7	-.381	.047	-.242	-.611
8	-.384	.048	-.241	-.635
9	-.357	.047	-.216	-.620
10	-.377	.051	-.223	-.683

DATA FOR PROJECT 6022 CONFIG. N WIND DIR. 21 TUBING NO. 1				
TAP	MEAN	RMS	MAX	MIN
1	.133	.137	.834	-.213
2	.180	.136	.848	-.150
3	.220	.132	.845	-.100
4	.242	.129	.815	-.119
5	.243	.109	.811	-.089
6	.202	.101	.686	-.081
7	.137	.086	.507	-.190
8	.071	.078	.455	-.173
9	.006	.074	.343	-.286
10	-.101	.060	.202	-.357

DATA FOR PROJECT 6022 CONFIG. N WIND DIR. 22 TUBING NO. 1				
TAP	MEAN	RMS	MAX	MIN
1	-.209	.061	.123	-.516
2	-.206	.069	.204	-.511
3	-.189	.077	.211	-.500
4	-.171	.068	.327	-.547
5	-.131	.105	.454	-.604
6	-.098	.119	.518	-.504
7	-.064	.119	.566	-.500
8	-.070	.119	.579	-.495
9	-.090	.111	.387	-.469
10	-.125	.094	.312	-.452

DATA FOR PROJECT 6022 CONFIG. N WIND DIR. 23 TUBING NO. 1				
TAP	MEAN	RMS	MAX	MIN
1	-.375	.055	-.206	-.621
2	-.377	.057	-.205	-.673
3	-.373	.060	-.187	-.706
4	-.372	.064	-.154	-.780
5	-.361	.070	-.005	-.691
6	-.341	.076	.009	-.626
7	-.303	.078	.225	-.703
8	-.291	.081	.131	-.642
9	-.288	.089	.097	-.677
10	-.291	.095	.087	-.877

DATA FOR PROJECT 6022 CONFIG. N WIND DIR. 24 TUBING NO. 1				
TAP	MEAN	RMS	MAX	MIN
1	-.407	.052	-.245	-.681
2	-.410	.053	-.238	-.688
3	-.408	.054	-.225	-.707
4	-.413	.057	-.221	-.754
5	-.409	.056	-.245	-.629
6	-.412	.063	-.212	-.678
7	-.401	.076	-.196	-.726
8	-.414	.084	-.171	-.790
9	-.420	.096	-.089	-.1.069
10	-.430	.109	-.095	-.1.209

DATA FOR PROJECT 6022 CONFIG. N WIND DIR. 25 TUBING NO. 1

TAP	MEAN	RMS	MAX	MIN	TAP	MEAN	RMS	MAX	MIN
1	.450	.047	.286	.642	11	.382	.046	.230	.545
2	.452	.047	.291	.648	12	.384	.045	.232	.534
3	.451	.048	.289	.646	13	.387	.043	.223	.533
4	.454	.050	.285	.665	14	.381	.043	.199	.546
5	.452	.053	.269	.665	15	.341	.043	.174	.482
6	.458	.058	.260	.709	16	.340	.045	.161	.493
7	.457	.065	.240	.787	17	.342	.048	.147	.497
8	.464	.072	.238	.990	18	.351	.048	.161	.505
9	.462	.075	.273	.989	19	.329	.045	.161	.473
10	.467	.079	.257	.927	20	.378	.047	.218	.534

DATA FOR PROJECT 6022 CONFIG. N WIND DIR. 111 TUBING NO. 1

TAP	MEAN	RMS	MAX	MIN	TAP	MEAN	RMS	MAX	MIN
1	.015	.047	.224	.148	11	.173	.060	.050	.499
2	.051	.046	.279	.117	12	.188	.061	.037	.513
3	.092	.055	.358	.108	13	.178	.059	.046	.468
4	.104	.057	.399	.097	14	.185	.060	.039	.489
5	.141	.057	.431	.049	15	.185	.060	.044	.453
6	.148	.063	.436	.100	16	.202	.059	.067	.472
7	.182	.075	.574	.085	17	.182	.056	.003	.398
8	.207	.095	.664	.128	18	.184	.057	.002	.397
9	.277	.117	.761	.099	19	.171	.054	.067	.397
10	.322	.168	.983	.201	20	.185	.058	.013	.513

DATA FOR PROJECT 6022 CONFIG. N WIND DIR. 112 TUBING NO. 1

TAP	MEAN	RMS	MAX	MIN	TAP	MEAN	RMS	MAX	MIN
1	.047	.054	.152	.302	11	.170	.101	.177	.942
2	.031	.049	.169	.250	12	.184	.104	.169	.094
3	.010	.049	.181	.189	13	.173	.103	.126	.169
4	.008	.049	.166	.211	14	.182	.101	.111	.983
5	.023	.049	.212	.202	15	.176	.083	.064	.722
6	.018	.054	.233	.233	16	.190	.078	.031	.679
7	.040	.068	.324	.236	17	.166	.069	.026	.643
8	.043	.079	.491	.350	18	.166	.069	.029	.581
9	.090	.084	.513	.315	19	.157	.074	.027	.776
10	.092	.121	.707	.550	20	.174	.090	.045	.070

DATA FOR PROJECT 6022 CONFIG. N WIND DIR. 114 TUBING NO. 1

TAP	MEAN	RMS	MAX	MIN	TAP	MEAN	RMS	MAX	MIN
1	.113	.047	.039	.300	11	.182	.070	.040	.907
2	.107	.046	.049	.275	12	.187	.068	.040	.919
3	.101	.045	.047	.258	13	.182	.065	.046	.831
4	.099	.046	.047	.251	14	.183	.063	.042	.673
5	.074	.046	.075	.228	15	.181	.058	.034	.491
6	.077	.048	.075	.245	16	.187	.056	.013	.455
7	.079	.048	.066	.275	17	.174	.052	.006	.404
8	.085	.052	.078	.343	18	.177	.054	.015	.499
9	.064	.054	.098	.417	19	.180	.062	.001	.763
10	.088	.061	.102	.529	20	.190	.071	.004	.923

DATA FOR PROJECT 6022 CONFIG. N WIND DIR. 115 TUBING NO. 1

TAP	MEAN	RMS	MAX	MIN	TAP	MEAN	RMS	MAX	MIN
1	.085	.045	.066	.236	11	.180	.045	.019	.372
2	.069	.046	.076	.217	12	.185	.045	.021	.372
3	.058	.045	.087	.224	13	.183	.045	.013	.358
4	.048	.047	.105	.215	14	.187	.046	.008	.372
5	.023	.048	.134	.187	15	.184	.043	.039	.376
6	.022	.051	.143	.203	16	.188	.044	.055	.372
7	.016	.057	.179	.174	17	.178	.043	.043	.358
8	.014	.061	.198	.185	18	.177	.045	.049	.361
9	.011	.063	.236	.167	19	.183	.048	.026	.379
10	.016	.068	.234	.203	20	.188	.050	.021	.417

DATA FOR PROJECT 6022 CONFIG. N WIND DIR. 121 TUBING NO. 1

TAP	MEAN	RMS	MAX	MIN	TAP	MEAN	RMS	MAX	MIN
1	.253	.137	.937	.103	11	.295	.049	.147	.564
2	.283	.131	.942	.086	12	.305	.049	.164	.553
3	.299	.123	.913	.064	13	.327	.054	.180	.557
4	.295	.117	.863	.031	14	.333	.055	.185	.553
5	.278	.113	.839	.046	15	.302	.056	.137	.548
6	.213	.101	.702	.078	16	.309	.062	.133	.624
7	.131	.083	.536	.117	17	.330	.071	.096	.665
8	.052	.072	.403	.177	18	.331	.077	.088	.723
9	.036	.058	.203	.244	19	.288	.073	.071	.698
10	.145	.050	.050	.345	20	.306	.080	.072	.778

DATA FOR PROJECT 6022 CONFIG. N WIND DIR. 122 TUBING NO. 1				
TAP	MEAN	RMS	MAX	MIN
1	.014	.081	.532	-.254
2	.039	.085	.572	-.221
3	.061	.090	.672	-.173
4	.079	.101	.712	-.183
5	.099	.108	.660	-.225
6	.096	.112	.680	-.177
7	.076	.104	.539	-.199
8	.035	.096	.496	-.226
9	.019	.088	.365	-.320
10	.093	.070	.248	-.332

DATA FOR PROJECT 6022 CONFIG. N WIND DIR. 124 TUBING NO. 1				
TAP	MEAN	RMS	MAX	MIN
1	-.134	.049	.018	-.348
2	-.135	.049	.012	-.378
3	-.133	.049	.012	-.402
4	-.137	.052	.023	-.431
5	-.133	.056	.044	-.537
6	-.138	.062	.119	-.609
7	-.133	.062	.297	-.444
8	-.143	.064	.176	-.551
9	-.153	.067	.481	-.494
10	-.167	.062	.311	-.522

DATA FOR PROJECT 6022 CONFIG. N WIND DIR. 125 TUBING NO. 1				
TAP	MEAN	RMS	MAX	MIN
1	-.084	.051	.076	-.245
2	-.093	.050	.054	-.259
3	-.100	.049	.046	-.265
4	-.110	.050	.041	-.281
5	-.119	.046	.032	-.299
6	-.130	.048	.037	-.339
7	-.134	.047	.036	-.352
8	-.152	.047	.010	-.367
9	-.166	.048	.062	-.431
10	-.182	.047	.026	-.467

DATA FOR PROJECT 6022 CONFIG. N WIND DIR. 234 TUBING NO. 1				
TAP	MEAN	RMS	MAX	MIN
1	-.138	.044	.016	-.302
2	-.117	.044	.035	-.264
3	-.112	.044	.050	-.299
4	-.100	.046	.093	-.239
5	-.092	.050	.069	-.253
6	-.092	.054	.083	-.376
7	-.097	.066	.129	-.485
8	-.103	.067	.123	-.389
9	-.108	.072	.142	-.439
10	-.134	.079	.327	-.509

DATA FOR PROJECT 6022 CONFIG. N WIND DIR. 244 TUBING NO. 1				
TAP	MEAN	RMS	MAX	MIN
1	-.174	.049	.016	-.461
2	-.170	.049	.011	-.439
3	-.173	.045	.016	-.398
4	-.181	.042	.046	-.351
5	-.187	.044	.076	-.355
6	-.189	.048	.113	-.382
7	-.194	.060	.043	-.527
8	-.197	.066	.103	-.545
9	-.193	.076	.269	-.613
10	-.188	.092	.489	-.687

DATA FOR PROJECT 6022 CONFIG. N WIND DIR. 254 TUBING NO. 1				
TAP	MEAN	RMS	MAX	MIN
1	-.091	.050	.084	-.512
2	-.089	.051	.094	-.537
3	-.085	.053	.162	-.569
4	-.084	.055	.155	-.346
5	-.083	.059	.141	-.394
6	-.083	.064	.177	-.540
7	-.069	.072	.292	-.491
8	-.056	.090	.381	-.576
9	-.045	.103	.444	-.592
10	-.042	.123	.721	-.940

DATA FOR PROJECT 6022 CONFIG. N WIND DIR. 334 TUBING NO. 1				
TAP	MEAN	RMS	MAX	MIN
1	-.109	.048	.039	-.273
2	-.105	.049	.102	-.287
3	-.100	.050	.092	-.300
4	-.106	.051	.072	-.361
5	-.104	.052	.095	-.307
6	-.116	.059	.149	-.473
7	-.119	.069	.260	-.600
8	-.136	.077	.380	-.563
9	-.157	.077	.349	-.628
10	-.184	.087	.565	-.696

DATA FOR PROJECT 6022 CONFIG. N WIND DIR. 344 TUBING NO. 1				
TAP	MEAN	RMS	MAX	MIN
1	-.197	.049	-.024	-.418
2	-.202	.045	-.038	-.380
3	-.201	.045	-.037	-.389
4	-.213	.047	-.047	-.472
5	-.201	.054	.053	-.557
6	-.205	.058	.074	-.462
7	-.194	.068	.191	-.493
8	-.198	.077	.250	-.538
9	-.186	.091	.371	-.590
10	-.183	.103	.589	-.797

DATA FOR PROJECT 6022 CONFIG. N WIND DIR. 354 TUBING NO. 1				
TAP	MEAN	RMS	MAX	MIN
1	-.097	.043	.048	-.258
2	-.093	.045	.074	-.307
3	-.082	.049	.096	-.354
4	-.091	.053	.107	-.342
5	-.060	.059	.244	-.280
6	-.054	.068	.316	-.438
7	-.023	.083	.379	-.361
8	-.025	.092	.523	-.382
9	-.013	.094	.590	-.305
10	-.023	.090	.573	-.428

DATA FOR PROJECT 6022 CONFIG. 0 WIND DIR. 11 TUBING NO. 1				
TAP	MEAN	RMS	MAX	MIN
1	.024	.067	.253	-.259
2	.046	.062	.356	-.169
3	.066	.064	.386	-.231
4	.079	.067	.401	-.185
5	.099	.075	.557	-.331
6	.095	.088	.637	-.430
7	.085	.096	.649	-.444
8	.066	.110	.700	-.544
9	.061	.119	.681	-.701
10	.006	.159	.631	-1.082

DATA FOR PROJECT 6022 CONFIG. 0 WIND DIR. 12 TUBING NO. 1				
TAP	MEAN	RMS	MAX	MIN
1	-.016	.056	.225	-.244
2	-.011	.055	.203	-.239
3	-.013	.056	.236	-.228
4	-.018	.058	.210	-.230
5	-.012	.059	.238	-.253
6	-.020	.065	.249	-.282
7	-.023	.077	.304	-.449
8	-.026	.086	.351	-.452
9	-.007	.094	.322	-.315
10	-.029	.144	.460	-.866

DATA FOR PROJECT 6022 CONFIG. 0 WIND DIR. 13 TUBING NO. 1				
TAP	MEAN	RMS	MAX	MIN
1	-.149	.075	.093	-.523
2	-.148	.070	.084	-.494
3	-.149	.066	.039	-.495
4	-.156	.062	.050	-.475
5	-.145	.059	.069	-.463
6	-.156	.060	.064	-.439
7	-.169	.064	.107	-.471
8	-.183	.072	.064	-.513
9	-.169	.081	.096	-.705
10	-.201	.107	.170	-.903

DATA FOR PROJECT 6022 CONFIG. 0 WIND DIR. 14 TUBING NO. 1

TAP	MEAN	RMS	MAX	MIN	TAP	MEAN	RMS	MAX	MIN
1	-.277	.091	-.050	-.742	11	-.229	.094	.274	-.862
2	-.280	.091	-.041	-.796	12	-.227	.092	.223	-.853
3	-.280	.082	-.017	-.733	13	-.215	.087	.156	-.707
4	-.285	.076	-.032	-.686	14	-.208	.086	.127	-.790
5	-.262	.067	-.024	-.543	15	-.212	.080	.151	-.694
6	-.266	.065	-.018	-.526	16	-.216	.078	.129	-.582
7	-.270	.067	-.018	-.594	17	-.203	.073	.076	-.494
8	-.2	.073	-.005	-.753	18	-.199	.073	.068	-.486
9	-.0	.076	-.011	-.729	19	-.187	.073	.034	-.542
10	-.283	.083	-.041	-.770	20	-.197	.077	.068	-.619

DATA FOR PROJECT 6022 CONFIG. 0 WIND DIR. 15 TUBING NO. 1

TAP	MEAN	RMS	MAX	MIN	TAP	MEAN	RMS	MAX	MIN
1	-.339	.084	-.064	-.765	11	-.289	.070	.062	-.686
2	-.343	.086	-.073	-.834	12	-.291	.072	.060	-.650
3	-.354	.091	-.137	-.835	13	-.273	.072	.032	-.630
4	-.365	.088	-.143	-.862	14	-.267	.073	.015	-.645
5	-.335	.079	-.127	-.772	15	-.253	.070	.012	-.546
6	-.337	.073	-.127	-.766	16	-.259	.070	-.002	-.533
7	-.322	.064	-.051	-.583	17	-.240	.067	-.018	-.520
8	-.335	.065	-.058	-.592	18	-.236	.065	-.019	-.492
9	-.304	.065	-.048	-.577	19	-.232	.063	-.012	-.636
10	-.323	.068	-.066	-.601	20	-.247	.068	-.019	-.788

DATA FOR PROJECT 6022 CONFIG. 0 WIND DIR. 21 TUBING NO. 1

TAP	MEAN	RMS	MAX	MIN	TAP	MEAN	RMS	MAX	MIN
1	-.124	.049	.038	-.322	11	-.099	.043	.044	-.278
2	-.124	.048	.021	-.372	12	-.105	.042	.039	-.284
3	-.115	.047	.027	-.357	13	-.109	.040	.025	-.239
4	-.112	.053	.052	-.325	14	-.114	.039	.021	-.237
5	-.104	.065	.198	-.436	15	-.096	.038	.034	-.218
6	-.090	.086	.345	-.438	16	-.108	.038	.018	-.230
7	-.056	.098	.415	-.493	17	-.115	.041	.021	-.265
8	-.044	.106	.576	-.441	18	-.124	.043	.011	-.306
9	-.047	.103	.468	-.409	19	-.106	.045	.030	-.308
10	-.069	.095	.383	-.441	20	-.128	.050	.032	-.468

DATA FOR PROJECT 6022 CONFIG. 0 WIND DIR. 22 TUBING NO. 1

TAP	MEAN	RMS	MAX	MIN	TAP	MEAN	RMS	MAX	MIN
1	-.137	.050	.062	-.314	11	-.081	.038	.034	-.225
2	-.141	.056	.116	-.357	12	-.089	.038	.029	-.227
3	-.128	.052	.199	-.363	13	-.092	.038	.066	-.216
4	-.115	.073	.306	-.372	14	-.096	.038	.053	-.217
5	-.064	.083	.378	-.358	15	-.073	.036	.055	-.188
6	-.027	.097	.628	-.343	16	-.085	.036	.055	-.210
7	-.012	.101	.661	-.377	17	-.092	.036	.045	-.212
8	-.009	.102	.624	-.410	18	-.105	.037	.022	-.231
9	-.001	.094	.486	-.300	19	-.084	.036	.048	-.212
10	-.034	.077	.337	-.301	20	-.113	.039	.025	-.251

DATA FOR PROJECT 6022 CONFIG. 0 WIND DIR. 23 TUBING NO. 1

TAP	MEAN	RMS	MAX	MIN	TAP	MEAN	RMS	MAX	MIN
1	-.171	.054	.048	-.383	11	-.106	.045	.050	-.315
2	-.178	.057	.076	-.410	12	-.114	.044	.042	-.323
3	-.165	.061	.158	-.407	13	-.112	.045	.044	-.273
4	-.162	.068	.183	-.427	14	-.116	.045	.045	-.287
5	-.133	.075	.358	-.392	15	-.088	.042	.043	-.272
6	-.122	.083	.363	-.407	16	-.099	.042	.028	-.252
7	-.091	.083	.329	-.390	17	-.102	.040	.031	-.230
8	-.092	.085	.372	-.394	18	-.118	.041	.007	-.253
9	-.093	.085	.414	-.504	19	-.099	.040	.037	-.229
10	-.110	.080	.298	-.451	20	-.134	.043	.008	-.286

DATA FOR PROJECT 6022 CONFIG. 0 WIND DIR. 24 TUBING NO. 1

TAP	MEAN	RMS	MAX	MIN	TAP	MEAN	RMS	MAX	MIN
1	-.265	.053	-.105	-.516	11	-.168	.051	.036	-.392
2	-.277	.056	-.109	-.553	12	-.172	.049	.008	-.385
3	-.266	.057	-.092	-.519	13	-.165	.052	.008	-.403
4	-.271	.062	-.061	-.546	14	-.170	.051	.004	-.399
5	-.257	.067	-.015	-.618	15	-.135	.047	.026	-.338
6	-.257	.071	.040	-.583	16	-.146	.047	.034	-.323
7	-.226	.075	.093	-.637	17	-.154	.051	.005	-.333
8	-.231	.083	.132	-.641	18	-.176	.052	-.026	-.352
9	-.233	.094	.098	-.833	19	-.159	.049	-.025	-.350
10	-.250	.106	.077	-1.001	20	-.206	.052	-.035	-.412

DATA FOR PROJECT 6022 CONFIG. 0 WIND DIR. 25 TUBING NO. 1				
TAP	MEAN	RMS	MAX	MIN
1	-.354	.053	-.126	-.608
2	-.369	.055	-.125	-.645
3	-.355	.057	-.100	-.633
4	-.362	.061	-.022	-.677
5	-.348	.068	-.126	-.640
6	-.362	.077	-.164	-.760
7	-.344	.091	-.059	-.798
8	-.361	.106	-.022	-1.075
9	-.376	.119	.132	-1.148
10	-.397	.129	.048	-1.131

DATA FOR PROJECT 6022 CONFIG. 0 WIND DIR. 111 TUBING NO. 1				
TAP	MEAN	RMS	MAX	MIN
1	.039	.065	.369	-.284
2	.063	.066	.424	-.274
3	.083	.074	.391	-.311
4	.093	.080	.440	-.248
5	.092	.085	.477	-.219
6	.056	.089	.461	-.208
7	.009	.086	.381	-.282
8	-.018	.067	.383	-.430
9	-.022	.089	.392	-.431
10	-.068	.114	.368	-.813

DATA FOR PROJECT 6022 CONFIG. 0 WIND DIR. 112 TUBING NO. 1				
TAP	MEAN	RMS	MAX	MIN
1	-.026	.053	.127	-.280
2	-.011	.049	.156	-.408
3	-.004	.046	.185	-.207
4	.003	.047	.198	-.258
5	.022	.051	.242	-.331
6	.022	.059	.280	-.224
7	.020	.075	.375	-.352
8	.009	.085	.410	-.414
9	.016	.091	.415	-.475
10	.017	.125	.414	-.742

DATA FOR PROJECT 6022 CONFIG. 0 WIND DIR. 114 TUBING NO. 1				
TAP	MEAN	RMS	MAX	MIN
1	-.094	.043	.060	-.236
2	-.092	.043	.074	-.298
3	-.091	.045	.073	-.327
4	-.094	.046	.072	-.319
5	-.074	.046	.082	-.290
6	-.083	.050	.077	-.327
7	-.090	.052	.109	-.382
8	-.105	.055	.118	-.366
9	-.089	.055	.140	-.479
10	-.116	.062	.120	-.844

DATA FOR PROJECT 6022 CONFIG. 0 WIND DIR. 115 TUBING NO. 1				
TAP	MEAN	RMS	MAX	MIN
1	-.085	.043	.045	-.252
2	-.078	.043	.063	-.245
3	-.071	.046	.085	-.210
4	-.075	.047	.081	-.226
5	-.046	.048	.098	-.206
6	-.054	.050	.093	-.228
7	-.067	.050	.122	-.240
8	-.092	.051	.098	-.251
9	-.075	.049	.101	-.253
10	-.110	.051	.073	-.357

DATA FOR PROJECT 6022 CONFIG. 0 WIND DIR. 121 TUBING NO. 1				
TAP	MEAN	RMS	MAX	MIN
1	-.166	.069	.094	-.466
2	-.157	.063	.072	-.433
3	-.144	.061	.059	-.354
4	-.137	.066	.071	-.404
5	-.117	.070	.211	-.428
6	-.105	.093	.370	-.568
7	-.069	.109	.393	-.477
8	-.057	.117	.505	-.534
9	-.053	.125	.651	-.466
10	-.069	.114	.625	-.968

DATA FOR PROJECT 6022 CONFIG. 0 WIND DIR. 122 TUBING NO. 1

TAP	MEAN	RMS	MAX	MIN	TAP	MEAN	RMS	MAX	MIN
1	-.100	.044	.035	-.265	11	-.095	.040	.024	-.227
2	-.104	.044	.035	-.272	12	-.106	.040	.022	-.240
3	-.095	.046	.051	-.274	13	-.104	.039	.049	-.231
4	-.098	.052	.077	-.374	14	-.113	.039	.035	-.240
5	-.080	.065	.234	-.410	15	-.090	.037	.058	-.204
6	-.059	.083	.388	-.366	16	-.105	.038	.049	-.226
7	-.022	.089	.406	-.402	17	-.115	.036	.062	-.258
8	-.018	.094	.369	-.388	18	-.127	.038	.049	-.265
9	-.021	.096	.483	-.369	19	-.100	.037	.064	-.221
10	-.053	.084	.475	-.359	20	-.124	.040	.053	-.274

DATA FOR PROJECT 6022 CONFIG. 0 WIND DIR. 124 TUBING NO. 1

TAP	MEAN	RMS	MAX	MIN	TAP	MEAN	RMS	MAX	MIN
1	-.114	.047	.057	-.357	11	-.098	.039	.046	-.254
2	-.124	.049	.055	-.422	12	-.109	.039	.035	-.257
3	-.113	.051	.079	-.427	13	-.115	.039	.002	-.252
4	-.117	.055	.099	-.341	14	-.124	.038	.013	-.255
5	-.104	.062	.294	-.364	15	-.096	.036	.010	-.218
6	-.108	.068	.406	-.415	16	-.112	.036	.005	-.234
7	-.087	.069	.458	-.375	17	-.119	.037	.015	-.245
8	-.094	.070	.421	-.371	18	-.131	.039	.011	-.262
9	-.089	.065	.406	-.373	19	-.099	.038	.014	-.218
10	-.105	.061	.307	-.388	20	-.122	.040	.002	-.311

DATA FOR PROJECT 6022 CONFIG. 0 WIND DIR. 125 TUBING NO. 1

TAP	MEAN	RMS	MAX	MIN	TAP	MEAN	RMS	MAX	MIN
1	-.150	.046	.021	-.364	11	-.139	.043	-.019	-.310
2	-.162	.047	.018	-.341	12	-.151	.043	-.029	-.315
3	-.149	.047	.033	-.323	13	-.159	.039	-.012	-.315
4	-.155	.050	.029	-.345	14	-.171	.039	-.034	-.328
5	-.147	.050	.054	-.407	15	-.139	.037	-.016	-.274
6	-.158	.054	.059	-.423	16	-.158	.037	-.029	-.291
7	-.142	.053	.069	-.395	17	-.163	.036	-.022	-.305
8	-.149	.054	.062	-.409	18	-.178	.038	-.030	-.324
9	-.147	.058	.097	-.463	19	-.138	.036	-.010	-.271
10	-.163	.058	.059	-.509	20	-.163	.038	-.009	-.298

DATA FOR PROJECT 6022 CONFIG. P WIND DIR. 35 TUBING NO. 1

TAP	MEAN	RMS	MAX	MIN	TAP	MEAN	RMS	MAX	MIN
1	-.124	.047	.009	-.320	11	-.226	.117	.083	-.991
2	-.114	.046	.011	-.338	12	-.240	.114	.101	-.912
3	-.131	.047	.028	-.331	13	-.213	.100	.080	-.766
4	-.147	.048	.012	-.372	14	-.196	.090	.066	-.673
5	-.097	.048	.066	-.347	15	-.201	.076	.092	-.642
6	-.095	.052	.070	-.389	16	-.209	.069	.055	-.496
7	-.117	.062	.110	-.554	17	-.176	.061	.050	-.451
8	-.130	.073	.122	-.676	18	-.160	.057	.059	-.420
9	-.069	.076	.217	-.501	19	-.171	.060	.018	-.409
10	-.064	.114	.408	-.984	20	-.196	.072	.023	-.824

DATA FOR PROJECT 6022 CONFIG. P WIND DIR. 36 TUBING NO. 1

TAP	MEAN	RMS	MAX	MIN	TAP	MEAN	RMS	MAX	MIN
1	-.082	.048	.102	-.335	11	-.207	.138	.111	-1.089
2	-.072	.047	.106	-.307	12	-.194	.126	.129	-1.002
3	-.088	.052	.105	-.442	13	-.171	.109	.142	-1.010
4	-.090	.054	.119	-.407	14	-.151	.097	.268	-1.044
5	-.060	.054	.138	-.312	15	-.149	.082	.118	-.646
6	-.065	.058	.180	-.340	16	-.139	.074	.098	-.521
7	-.079	.064	.208	-.579	17	-.125	.066	.085	-.491
8	-.079	.073	.253	-.693	18	-.114	.064	.086	-.496
9	-.035	.079	.281	-.941	19	-.114	.059	.085	-.459
10	-.055	.121	.434	-1.412	20	-.118	.062	.081	-.538

DATA FOR PROJECT 6022 CONFIG. P WIND DIR. 37 TUBING NO. 1

TAP	MEAN	RMS	MAX	MIN	TAP	MEAN	RMS	MAX	MIN
1	-.019	.054	.222	-.280	11	-.219	.178	.122	-1.504
2	-.012	.054	.252	-.301	12	-.201	.163	.122	-1.344
3	-.015	.061	.312	-.343	13	-.173	.135	.152	-1.309
4	-.011	.062	.287	-.280	14	-.143	.111	.185	-.814
5	-.016	.063	.271	-.253	15	-.128	.095	.125	-.801
6	-.015	.070	.307	-.260	16	-.112	.087	.184	-.673
7	-.006	.077	.339	-.310	17	-.096	.075	.169	-.485
8	-.014	.085	.401	-.305	18	-.086	.072	.164	-.488
9	-.060	.089	.471	-.293	19	-.085	.070	.175	-.437
10	-.049	.129	.616	-.756	20	-.085	.072	.208	-.456

DATA FOR PROJECT 6022 CONFIG. P WIND DIR. 145 TUBING NO. 1				
TAP	MEAN	RMS	MAX	MIN
1	.122	.060	.058	.536
2	.128	.060	.061	.569
3	.127	.060	.096	.528
4	.125	.065	.140	.463
5	.120	.076	.554	.499
6	.111	.093	.342	.454
7	.086	.102	.440	.518
8	.080	.104	.413	.515
9	.082	.107	.493	.427
10	.108	.091	.373	.461

DATA FOR PROJECT 6022 CONFIG. P WIND DIR. 146 TUBING NO. 1				
TAP	MEAN	RMS	MAX	MIN
1	.115	.057	.120	.388
2	.149	.060	.153	.486
3	.113	.061	.331	.444
4	.106	.065	.306	.426
5	.094	.070	.323	.378
6	.106	.090	.567	.419
7	.065	.098	.543	.388
8	.057	.101	.495	.375
9	.059	.102	.619	.415
10	.113	.089	.388	.447

DATA FOR PROJECT 6022 CONFIG. P WIND DIR. 147 TUBING NO. 1				
TAP	MEAN	RMS	MAX	MIN
1	.024	.087	.569	.394
2	.023	.085	.585	.371
3	.026	.085	.698	.361
4	.034	.091	.776	.386
5	.046	.109	.706	.326
6	.052	.117	.647	.285
7	.051	.113	.762	.241
8	.047	.109	.606	.245
9	.015	.098	.559	.280
10	.023	.079	.437	.402

DATA FOR PROJECT 6022 CONFIG. Q WIND DIR. 35 TUBING NO. 1				
TAP	MEAN	RMS	MAX	MIN
1	.118	.062	.089	.364
2	.045	.063	.192	.279
3	.009	.072	.253	.271
4	.064	.075	.323	.222
5	.127	.078	.403	.154
6	.198	.087	.551	.095
7	.257	.093	.542	.059
8	.334	.110	.716	.047
9	.418	.124	.847	.014
10	.449	.159	.968	.129

DATA FOR PROJECT 6022 CONFIG. Q WIND DIR. 36 TUBING NO. 1				
TAP	MEAN	RMS	MAX	MIN
1	.050	.095	.418	.375
2	.033	.100	.395	.368
3	.042	.098	.453	.335
4	.038	.098	.468	.426
5	.036	.088	.384	.372
6	.061	.097	.422	.638
7	.092	.113	.443	.522
8	.097	.123	.604	.600
9	.075	.129	.418	.659
10	.148	.222	.605	.511

DATA FOR PROJECT 6022 CONFIG. Q WIND DIR. 37 TUBING NO. 1				
TAP	MEAN	RMS	MAX	MIN
1	.026	.071	.236	.320
2	.012	.073	.281	.302
3	.009	.078	.336	.277
4	.006	.082	.408	.306
5	.026	.084	.469	.382
6	.024	.093	.553	.524
7	.024	.111	.591	.433
8	.052	.124	.564	.476
9	.104	.134	.594	.487
10	.109	.203	.792	.992

DATA FOR PROJECT 6022 CONFIG. Q WIND DIR. 145 TUBING NO. 1

TAP	MEAN	RMS	MAX	MIN	TAP	MEAN	RMS	MAX	MIN
1	.383	.128	.857	.021	11	-.394	.079	-.186	-.789
2	.323	.117	.769	-.026	12	-.401	.080	-.202	-.734
3	.266	.105	.702	-.009	13	-.416	.081	-.204	-.615
4	.212	.099	.650	-.062	14	-.415	.081	-.213	-.778
5	.152	.095	.672	-.047	15	-.369	.078	-.169	-.726
6	.092	.092	.601	-.161	16	-.364	.079	-.141	-.697
7	.031	.082	.495	-.206	17	-.374	.085	-.127	-.602
8	-.030	.075	.367	-.287	18	-.370	.085	-.120	-.827
9	-.100	.065	.162	-.345	19	-.329	.080	-.122	-.743
10	-.221	.062	.023	-.494	20	-.347	.082	-.113	-.761

DATA FOR PROJECT 6022 CONFIG. Q WIND DIR. 146 TUBING NO. 1

TAP	MEAN	RMS	MAX	MIN	TAP	MEAN	RMS	MAX	MIN
1	.065	.143	.734	-.513	11	-.154	.062	.031	-.455
2	.023	.121	.581	-.490	12	-.158	.064	.027	-.461
3	-.000	.106	.508	-.378	13	-.178	.073	.051	-.618
4	-.011	.109	.559	-.385	14	-.192	.079	.040	-.641
5	-.020	.105	.528	-.540	15	-.179	.083	.055	-.673
6	-.020	.123	.777	-.494	16	-.205	.095	.061	-.646
7	-.017	.128	.669	-.465	17	-.243	.101	.116	-.763
8	-.021	.133	.679	-.554	18	-.273	.107	.096	-.808
9	-.044	.137	.561	-.604	19	-.252	.104	.132	-.905
10	-.088	.121	.491	-.627	20	-.270	.110	.013	-.955

DATA FOR PROJECT 6022 CONFIG. Q WIND DIR. 147 TUBING NO. 1

TAP	MEAN	RMS	MAX	MIN	TAP	MEAN	RMS	MAX	MIN
1	.149	.146	.764	-.359	11	-.165	.077	.028	-.538
2	.103	.128	.617	-.270	12	-.166	.079	.060	-.552
3	.071	.115	.610	-.270	13	-.185	.088	.067	-.816
4	.049	.113	.652	-.315	14	-.196	.095	.084	-.830
5	.023	.106	.547	-.326	15	-.185	.097	.071	-.763
6	-.002	.105	.518	-.333	16	-.209	.104	.086	-.718
7	-.008	.096	.428	-.303	17	-.234	.108	.057	-.836
8	-.024	.093	.476	-.292	18	-.242	.109	.064	-.796
9	-.049	.089	.424	-.403	19	-.203	.097	.061	-.760
10	-.096	.075	.356	-.425	20	-.209	.099	.070	-.802

DATA FOR PROJECT 6022 CONFIG. R WIND DIR. 11 TUBING NO. 1

TAP	MEAN	RMS	MAX	MIN	TAP	MEAN	RMS	MAX	MIN
1	-.043	.069	.221	-.347	11	-1.618	.760	.064	-4.264
2	-.010	.074	.290	-.329	12	-.515	.178	-.077	-2.169
3	-.048	.083	.333	-.335	13	-.491	.155	-.081	-1.555
4	-.074	.087	.381	-.390	14	-.600	.203	-.039	-1.461
5	-.101	.084	.396	-.309	15	-.590	.166	-.054	-1.279
6	-.103	.089	.460	-.182	16	-.470	.155	.129	-1.263
7	-.119	.103	.543	-.254	17	-.383	.142	.123	-.987
8	-.160	.115	.620	-.326	18	-.358	.144	.147	-1.234
9	-.227	.123	.685	-.341	19	-.351	.153	.104	-1.197
10	-.304	.156	.886	-.435	20	-.334	.153	.125	-1.121

DATA FOR PROJECT 6022 CONFIG. R WIND DIR. 21 TUBING NO. 1

TAP	MEAN	RMS	MAX	MIN	TAP	MEAN	RMS	MAX	MIN
1	.174	.171	.959	-.306	11	-.394	.102	-.074	-.939
2	.248	.173	.694	-.364	12	-.419	.103	-.079	-.928
3	.281	.175	.945	-.305	13	-.439	.105	-.146	-.913
4	.330	.177	.660	-.209	14	-.461	.115	-.160	-.948
5	.375	.158	.987	-.204	15	-.553	.136	-.155	-1.128
6	.395	.147	.984	-.120	16	-.655	.173	-.192	-1.408
7	.342	.129	.621	-.187	17	-.659	.217	-.054	-1.752
8	.275	.115	.780	-.149	18	-.532	.202	-.113	-1.454
9	.185	.093	.543	-.198	19	-.649	.221	-.057	-1.925
10	.041	.074	.350	-.274	20	-.735	.237	-.152	-1.941

DATA FOR PROJECT 6022 CONFIG. R WIND DIR. 12 TUBING NO. 1

TAP	MEAN	RMS	MAX	MIN	TAP	MEAN	RMS	MAX	MIN
1	-.084	.055	.083	-.299	11	-.509	.288	.066	-2.389
2	-.081	.057	.118	-.296	12	-.311	.167	.086	-1.348
3	-.086	.060	.149	-.363	13	-.257	.118	.083	-.978
4	-.078	.064	.189	-.359	14	-.259	.117	.092	-.859
5	-.055	.067	.232	-.391	15	-.227	.107	.085	-.822
6	-.059	.074	.278	-.533	16	-.200	.099	.162	-.926
7	-.052	.090	.313	-.444	17	-.176	.083	.079	-.823
8	-.035	.102	.360	-.520	18	-.167	.076	.079	-.563
9	-.005	.109	.432	-.511	19	-.155	.073	.082	-.626
10	-.004	.150	.600	-.862	20	-.151	.077	.103	-.610

DATA FOR PROJECT 6022 CONFIG. R					WIND DIR. 22 TUBING NO. 1				
TAP	MEAN	RMS	MAX	MIN	TAP	MEAN	RMS	MAX	MIN
1	-.034	.099	.619	-.317	11	-.185	.091	.073	-.684
2	-.003	.102	.699	-.304	12	-.196	.080	.048	-.670
3	.000	.106	.742	-.310	13	-.201	.072	.024	-.544
4	.017	.116	.772	-.254	14	-.199	.074	.030	-.554
5	.039	.115	.674	-.340	15	-.217	.079	-.005	-.625
6	.067	.130	.661	-.344	16	-.239	.094	.011	-.898
7	.061	.131	.702	-.297	17	-.240	.110	.031	-1.105
8	.050	.127	.705	-.318	18	-.230	.114	.054	-.861
9	.032	.119	.550	-.360	19	-.285	.136	.041	-1.054
10	-.014	.096	.418	-.365	20	-.341	.155	.051	-1.452

DATA FOR PROJECT 6022 CONFIG. R					WIND DIR. 13 TUBING NO. 1				
TAP	MEAN	RMS	MAX	MIN	TAP	MEAN	RMS	MAX	MIN
1	-.105	.052	.090	-.339	11	-.516	.273	.041	-2.598
2	-.102	.054	.153	-.313	12	-.344	.164	.044	-1.846
3	-.102	.057	.093	-.408	13	-.277	.113	.081	-1.051
4	-.102	.060	.132	-.487	14	-.280	.115	.097	-.974
5	-.066	.061	.180	-.564	15	-.248	.097	.067	-.717
6	-.071	.067	.183	-.643	16	-.225	.091	.216	-.870
7	-.063	.077	.314	-.620	17	-.196	.078	.113	-.690
8	-.054	.087	.367	-.544	18	-.187	.072	.057	-.670
9	-.013	.091	.403	-.442	19	-.179	.072	.041	-.629
10	-.012	.122	.539	-.706	20	-.183	.074	.058	-.709

DATA FOR PROJECT 6022 CONFIG. R					WIND DIR. 23 TUBING NO. 1				
TAP	MEAN	RMS	MAX	MIN	TAP	MEAN	RMS	MAX	MIN
1	-.061	.083	.463	-.349	11	-.154	.063	.034	-.622
2	-.050	.088	.586	-.376	12	-.160	.062	.031	-.647
3	-.038	.092	.609	-.342	13	-.161	.059	.072	-.549
4	-.021	.100	.839	-.320	14	-.166	.060	.064	-.471
5	.016	.111	.726	-.369	15	-.169	.061	.034	-.472
6	.036	.121	.752	-.329	16	-.181	.068	-.013	-.647
7	.044	.121	.667	-.280	17	-.179	.074	.031	-.628
8	.036	.119	.649	-.313	18	-.175	.077	.027	-.644
9	.016	.107	.443	-.349	19	-.182	.082	.014	-.733
10	-.033	.087	.447	-.346	20	-.198	.091	-.009	-.884

DATA FOR PROJECT 6022 CONFIG. R					WIND DIR. 14 TUBING NO. 1				
TAP	MEAN	RMS	MAX	MIN	TAP	MEAN	RMS	MAX	MIN
1	-.155	.059	.142	-.387	11	-1.179	.439	-.110	-2.976
2	-.144	.063	.192	-.377	12	-.466	.112	-.168	-1.090
3	-.140	.070	.096	-.457	13	-.421	.095	-.121	-.818
4	-.128	.067	.099	-.659	14	-.365	.106	-.053	-1.043
5	-.111	.067	.130	-.520	15	-.474	.153	-.064	-1.101
6	-.116	.068	.159	-.478	16	-.424	.139	-.026	-1.000
7	-.095	.080	.193	-.469	17	-.326	.105	.019	-.812
8	-.092	.080	.208	-.412	18	-.296	.090	.002	-.740
9	-.053	.096	.288	-.457	19	-.280	.088	.012	-.736
10	-.034	.120	.391	-.684	20	-.262	.079	-.023	-.630

DATA FOR PROJECT 6022 CONFIG. R					WIND DIR. 24 TUBING NO. 1				
TAP	MEAN	RMS	MAX	MIN	TAP	MEAN	RMS	MAX	MIN
1	-.034	.097	.539	-.386	11	-.342	.074	-.126	-.610
2	.015	.113	.780	-.444	12	-.349	.074	-.133	-.673
3	.066	.134	.856	-.333	13	-.369	.075	-.151	-.712
4	.144	.160	.919	-.313	14	-.403	.083	-.158	-.910
5	.273	.178	.954	-.404	15	-.479	.109	-.167	-1.047
6	.357	.170	.981	-.206	16	-.536	.133	-.203	-1.199
7	.380	.144	.822	-.119	17	-.465	.157	-.113	-1.230
8	.342	.124	.708	-.151	18	-.389	.130	-.060	-1.025
9	.261	.107	.642	-.154	19	-.415	.121	-.092	-1.118
10	.107	.084	.433	-.267	20	-.440	.125	-.071	-1.134

DATA FOR PROJECT 6022 CONFIG. R					WIND DIR. 111 TUBING NO. 1				
TAP	MEAN	RMS	MAX	MIN	TAP	MEAN	RMS	MAX	MIN
1	.057	.064	.319	-.253	11	-.689	.189	-.177	-1.798
2	.063	.065	.319	-.215	12	-.637	.179	-.079	-1.586
3	.066	.064	.347	-.156	13	-.661	.187	-.119	-1.718
4	.066	.065	.338	-.191	14	-.596	.214	.058	-1.370
5	.041	.067	.331	-.203	15	-.236	.167	.096	-.958
6	.014	.074	.298	-.250	16	-.095	.086	.179	-.603
7	.001	.091	.431	-.366	17	-.057	.063	.231	-.357
8	.023	.105	.531	-.448	18	-.036	.063	.204	-.339
9	.058	.116	.619	-.387	19	-.028	.072	.242	-.387
10	.090	.155	.756	-.694	20	-.010	.073	.252	-.384

DATA FOR PROJECT 6022 CONFIG. R WIND DIR. 121 TUBING NO. 1				
TAP	MEAN	RMS	MAX	MIN
1	.029	.116	.528	-.295
2	.077	.119	.598	-.285
3	.113	.119	.687	-.226
4	.142	.120	.625	-.295
5	.178	.118	.784	-.221
6	.184	.114	.736	-.277
7	.161	.098	.671	-.355
8	.116	.089	.629	-.371
9	.069	.076	.433	-.209
10	.017	.064	.289	-.240

DATA FOR PROJECT 6022 CONFIG. R WIND DIR. 112 TUBING NO. 1				
TAP	MEAN	RMS	MAX	MIN
1	-.028	.058	.240	-.225
2	-.027	.058	.247	-.208
3	-.024	.050	.182	-.206
4	-.014	.051	.210	-.243
5	-.013	.053	.224	-.330
6	-.026	.054	.243	-.382
7	-.023	.073	.421	-.313
8	-.004	.083	.443	-.392
9	-.014	.092	.531	-.346
10	.014	.125	.656	-.775

DATA FOR PROJECT 6022 CONFIG. R WIND DIR. 122 TUBING NO. 1				
TAP	MEAN	RMS	MAX	MIN
1	.033	.102	.673	-.263
2	.060	.103	.764	-.224
3	.071	.103	.724	-.207
4	.077	.104	.693	-.211
5	.099	.104	.751	-.189
6	.099	.103	.823	-.211
7	.079	.098	.655	-.256
8	.050	.093	.496	-.253
9	.019	.084	.349	-.321
10	-.023	.072	.329	-.338

DATA FOR PROJECT 6022 CONFIG. R WIND DIR. 113 TUBING NO. 1				
TAP	MEAN	RMS	MAX	MIN
1	-.049	.045	.129	-.219
2	-.052	.045	.142	-.216
3	-.053	.049	.167	-.223
4	-.047	.050	.147	-.258
5	-.043	.051	.176	-.250
6	-.058	.056	.177	-.299
7	-.062	.065	.214	-.458
8	-.050	.072	.259	-.574
9	-.037	.078	.281	-.495
10	-.043	.106	.431	-.843

DATA FOR PROJECT 6022 CONFIG. R WIND DIR. 123 TUBING NO. 1				
TAP	MEAN	RMS	MAX	MIN
1	-.040	.084	.490	-.307
2	-.019	.089	.548	-.262
3	-.003	.091	.517	-.275
4	.005	.096	.680	-.307
5	.021	.096	.670	-.323
6	.026	.095	.662	-.312
7	.019	.089	.509	-.266
8	-.002	.085	.454	-.282
9	-.019	.078	.368	-.352
10	-.052	.066	.274	-.321

DATA FOR PROJECT 6022 CONFIG. R WIND DIR. 211 TUBING NO. 1				
TAP	MEAN	RMS	MAX	MIN
1	-.043	.059	.158	-.295
2	-.026	.064	.207	-.266
3	-.034	.072	.219	-.300
4	-.036	.071	.211	-.511
5	-.054	.074	.236	-.513
6	-.087	.082	.220	-.463
7	-.101	.098	.340	-.677
8	-.112	.105	.252	-.473
9	-.080	.121	.303	-.594
10	-.103	.189	.441	-1.315

DATA FOR PROJECT 6022 CONFIG. R WIND DIR. 221 TUBING NO. 1

TAP	MEAN	RMS	MAX	MIN	TAP	MEAN	RMS	MAX	MIN
1	-.109	.108	.396	-.523	11	-.378	.084	-.149	-.840
2	-.052	.119	.547	-.418	12	-.387	.083	-.139	-.801
3	.015	.130	.688	-.390	13	-.406	.080	-.190	-.819
4	.077	.150	.738	-.329	14	-.429	.082	-.186	-.826
5	.188	.160	.788	-.255	15	-.442	.097	-.159	-.847
6	.225	.159	.820	-.324	16	-.453	.124	-.139	-.985
7	.233	.130	.798	-.274	17	-.398	.130	-.166	-.963
8	.182	.111	.671	-.285	18	-.410	.130	-.099	-1.617
9	.099	.096	.504	-.298	19	-.482	.165	-.069	-1.260
10	-.068	.077	.285	-.395	20	-.572	.189	-.115	-1.471

DATA FOR PROJECT 6022 CONFIG. R WIND DIR. 311 TUBING NO. 1

TAP	MEAN	RMS	MAX	MIN	TAP	MEAN	RMS	MAX	MIN
1	-.117	.046	.065	-.260	11	-.822	.293	-.130	-2.377
2	-.095	.048	.097	-.250	12	-.525	.141	-.147	-1.116
3	-.075	.047	.099	-.230	13	-.458	.119	-.125	-.923
4	-.072	.055	.149	-.306	14	-.428	.102	-.099	-.981
5	-.072	.060	.167	-.375	15	-.388	.092	-.105	-.789
6	-.086	.067	.221	-.500	16	-.330	.088	-.103	-.747
7	-.093	.079	.253	-.398	17	-.324	.090	-.069	-.831
8	-.102	.099	.378	-.442	18	-.325	.090	-.065	-.732
9	-.055	.117	.483	-.506	19	-.308	.089	-.099	-.661
10	.021	.152	.673	-.867	20	-.298	.076	-.093	-.598

DATA FOR PROJECT 6022 CONFIG. R WIND DIR. 321 TUBING NO. 1

TAP	MEAN	RMS	MAX	MIN	TAP	MEAN	RMS	MAX	MIN
1	-.014	.114	.650	-.395	11	-.319	.051	-.150	-.537
2	.016	.105	.752	-.270	12	-.323	.050	-.168	-.512
3	.027	.086	.609	-.234	13	-.324	.048	-.158	-.503
4	.036	.081	.597	-.225	14	-.329	.051	-.148	-.533
5	.048	.067	.351	-.195	15	-.340	.055	-.160	-.537
6	.046	.065	.279	-.211	16	-.355	.061	-.165	-.616
7	.027	.057	.211	-.208	17	-.371	.071	-.160	-.745
8	-.010	.051	.163	-.235	18	-.369	.075	-.112	-.674
9	-.062	.048	.153	-.315	19	-.394	.091	-.134	-.817
10	-.142	.046	.029	-.316	20	-.445	.116	-.121	-1.043

DATA FOR PROJECT 6022 CONFIG. S WIND DIR. 11 TUBING NO. 1

TAP	MEAN	RMS	MAX	MIN	TAP	MEAN	RMS	MAX	MIN
1	-.109	.075	.180	-.387	11	-.973	.515	-.032	-4.320
2	-.073	.080	.250	-.351	12	-.457	.267	.021	-1.674
3	-.051	.093	.359	-.543	13	-.440	.171	.010	-1.554
4	-.020	.095	.386	-.571	14	-.442	.177	.110	-1.311
5	.006	.091	.453	-.370	15	-.416	.169	.130	-1.239
6	.018	.098	.517	-.371	16	-.359	.153	.162	-1.164
7	.042	.110	.570	-.422	17	-.339	.126	.063	-.934
8	.075	.123	.690	-.392	18	-.323	.114	.216	-.781
9	.110	.129	.643	-.350	19	-.306	.107	.042	-.876
10	.122	.169	.858	-.798	20	-.287	.106	.049	-1.050

DATA FOR PROJECT 6022 CONFIG. S WIND DIR. 21 TUBING NO. 1

TAP	MEAN	RMS	MAX	MIN	TAP	MEAN	RMS	MAX	MIN
1	.263	.182	1.067	-.356	11	-.390	.121	-.089	-1.057
2	.284	.174	1.012	-.251	12	-.403	.119	-.052	-.978
3	.270	.167	.890	-.227	13	-.459	.124	-.095	-1.046
4	.274	.168	1.048	-.209	14	-.462	.126	-.093	-1.032
5	.268	.175	1.084	-.274	15	-.521	.144	-.089	-1.141
6	.271	.165	.992	-.383	16	-.564	.173	-.104	-1.511
7	.229	.148	.877	-.182	17	-.601	.197	-.140	-1.410
8	.184	.135	.770	-.248	18	-.624	.215	-.079	-1.559
9	.103	.108	.513	-.279	19	-.745	.251	-.198	-1.910
10	-.013	.092	.428	-.416	20	-.767	.274	-.097	-1.985

DATA FOR PROJECT 6022 CONFIG. S WIND DIR. 12 TUBING NO. 1

TAP	MEAN	RMS	MAX	MIN	TAP	MEAN	RMS	MAX	MIN
1	-.088	.069	.189	-.345	11	-.677	.360	.156	-2.764
2	-.071	.071	.201	-.342	12	-.341	.167	.136	-1.508
3	-.078	.077	.239	-.366	13	-.296	.109	.120	-.889
4	-.060	.079	.264	-.337	14	-.326	.132	.144	-1.032
5	-.032	.079	.277	-.310	15	-.329	.134	.094	-.997
6	-.024	.085	.351	-.302	16	-.278	.129	.200	-1.002
7	-.018	.091	.413	-.363	17	-.244	.113	.130	-.876
8	.005	.100	.426	-.408	18	-.225	.106	.164	-.832
9	.034	.106	.485	-.329	19	-.206	.107	.183	-.806
10	.033	.137	.657	-.645	20	-.192	.106	.159	-.695

DATA FOR PROJECT 6022 CONFIG. S WIND DIR. 22 TUBING NO. 1

TAP	MEAN	RMS	MAX	MIN	TAP	MEAN	RMS	MAX	MIN
1	.065	.119	.770	-.270	11	-.236	.086	-.014	-.709
2	.102	.119	.829	-.231	12	-.241	.083	-.013	-.667
3	.100	.121	.809	-.184	13	-.272	.085	-.027	-.725
4	.119	.128	.944	-.192	14	-.274	.088	-.020	-.716
5	.135	.131	.790	-.218	15	-.326	.104	-.048	-.934
6	.159	.138	.732	-.201	16	-.356	.131	-.027	-1.129
7	.137	.134	.633	-.250	17	-.334	.139	-.021	-1.314
8	.117	.126	.582	-.272	18	-.299	.131	-.050	-1.405
9	.065	.111	.476	-.293	19	-.379	.162	-.028	-1.351
10	.001	.091	.361	-.351	20	-.422	.182	-.046	-1.521

DATA FOR PROJECT 6022 CONFIG. S WIND DIR. 13 TUBING NO. 1

TAP	MEAN	RMS	MAX	MIN	TAP	MEAN	RMS	MAX	MIN
1	-.106	.057	.133	-.405	11	-.521	.290	-.004	-2.681
2	-.085	.058	.160	-.330	12	-.309	.152	.038	-1.290
3	-.087	.057	.165	-.324	13	-.260	.097	.026	-.874
4	-.081	.060	.152	-.333	14	-.264	.106	.090	-.958
5	-.051	.060	.181	-.324	15	-.239	.099	.100	-.751
6	-.044	.065	.252	-.373	16	-.216	.090	.112	-.677
7	-.041	.076	.276	-.314	17	-.194	.079	.159	-.631
8	-.030	.087	.358	-.387	18	-.179	.074	.107	-.575
9	-.006	.092	.463	-.427	19	-.184	.082	.136	-.562
10	.003	.118	.599	-.594	20	-.185	.087	.172	-.774

DATA FOR PROJECT 6022 CONFIG. S WIND DIR. 23 TUBING NO. 1

TAP	MEAN	RMS	MAX	MIN	TAP	MEAN	RMS	MAX	MIN
1	.044	.111	.773	-.268	11	-.194	.073	-.001	-.772
2	.073	.108	.819	-.245	12	-.200	.071	-.006	-.714
3	.064	.108	.781	-.231	13	-.219	.074	-.014	-.572
4	.075	.112	.752	-.315	14	-.209	.077	-.049	-.645
5	.077	.108	.614	-.226	15	-.244	.089	-.008	-.785
6	.095	.111	.618	-.215	16	-.259	.105	-.016	-.941
7	.074	.111	.759	-.257	17	-.267	.111	-.001	-1.412
8	.055	.106	.623	-.246	18	-.246	.115	-.006	-.913
9	.019	.099	.555	-.329	19	-.296	.134	-.015	-1.330
10	-.023	.083	.383	-.361	20	-.310	.144	-.016	-1.360

DATA FOR PROJECT 6022 CONFIG. S WIND DIR. 14 TUBING NO. 1

TAP	MEAN	RMS	MAX	MIN	TAP	MEAN	RMS	MAX	MIN
1	-.171	.061	.137	-.403	11	-.821	.377	-.037	-3.096
2	-.154	.063	.180	-.438	12	-.419	.165	.039	-1.357
3	-.144	.063	.126	-.342	13	-.356	.115	.052	-.917
4	-.129	.068	.152	-.356	14	-.363	.125	.076	-1.030
5	-.107	.071	.239	-.357	15	-.357	.112	.036	-.963
6	-.101	.078	.265	-.435	16	-.330	.097	.069	-.783
7	-.080	.088	.252	-.416	17	-.295	.079	.072	-.704
8	-.070	.098	.308	-.458	18	-.287	.073	.070	-.731
9	-.041	.105	.393	-.439	19	-.287	.072	-.008	-.552
10	-.038	.129	.480	-.704	20	-.278	.075	-.054	-.790

DATA FOR PROJECT 6022 CONFIG. S WIND DIR. 24 TUBING NO. 1

TAP	MEAN	RMS	MAX	MIN	TAP	MEAN	RMS	MAX	MIN
1	.098	.126	.803	-.283	11	-.361	.089	-.108	-.755
2	.110	.128	.632	-.240	12	-.362	.082	-.108	-.733
3	.106	.124	.750	-.241	13	-.373	.075	-.119	-.786
4	.111	.131	.780	-.269	14	-.369	.072	-.106	-.656
5	.119	.140	.923	-.218	15	-.383	.074	-.161	-.728
6	.144	.155	.816	-.324	16	-.383	.082	-.149	-.787
7	.144	.159	.743	-.348	17	-.386	.102	-.098	-.955
8	.124	.154	.688	-.302	18	-.375	.105	-.106	-1.058
9	.063	.137	.606	-.350	19	-.374	.106	-.128	-1.119
10	-.031	.122	.401	-.505	20	-.371	.107	-.115	-1.060

DATA FOR PROJECT 6022 CONFIG. S WIND DIR. 111 TUBING NO. 1

TAP	MEAN	RMS	MAX	MIN	TAP	MEAN	RMS	MAX	MIN
1	.036	.071	.370	-.207	11	-.568	.259	-.003	-1.780
2	.063	.072	.413	-.169	12	-.550	.244	-.002	-1.580
3	.098	.083	.423	-.269	13	-.574	.261	-.023	-1.751
4	.128	.085	.443	-.230	14	-.480	.241	.053	-1.576
5	.150	.087	.538	-.170	15	-.211	.123	.114	-.924
6	.154	.095	.505	-.194	16	-.132	.088	.214	-.793
7	.170	.115	.699	-.174	17	-.122	.083	.206	-.555
8	.192	.129	.773	-.260	18	-.113	.080	.145	-.542
9	.212	.144	.788	-.207	19	-.114	.082	.201	-.495
10	.218	.179	.874	-.341	20	-.104	.085	.197	-.683

DATA FOR PROJECT 6022 CONFIG. S WIND DIR. 121 TUBING NO. 1				
TAP	MEAN	RMS	MAX	MIN
1	.192	.116	.608	-.276
2	.226	.116	.637	-.174
3	.250	.114	.642	-.102
4	.254	.119	.679	-.125
5	.260	.117	.688	-.084
6	.223	.116	.641	-.141
7	.167	.095	.583	-.221
8	.101	.085	.523	-.268
9	.056	.074	.348	-.212
10	-.032	.064	.306	-.281

DATA FOR PROJECT 6022 CONFIG. S WIND DIR. 112 TUBING NO. 1				
TAP	MEAN	RMS	MAX	MIN
1	.003	.059	.302	-.255
2	.003	.059	.306	-.247
3	.012	.060	.325	-.271
4	.028	.061	.332	-.232
5	.035	.063	.358	-.219
6	.024	.071	.450	-.231
7	.021	.080	.370	-.315
8	.034	.087	.403	-.307
9	.040	.095	.450	-.359
10	.021	.123	.519	-.850

DATA FOR PROJECT 6022 CONFIG. S WIND DIR. 122 TUBING NO. 1				
TAP	MEAN	RMS	MAX	MIN
1	.037	.100	.483	-.332
2	.063	.105	.569	-.374
3	.092	.109	.674	-.259
4	.107	.117	.732	-.186
5	.122	.102	.631	-.217
6	.113	.102	.624	-.200
7	.097	.093	.526	-.233
8	.059	.085	.439	-.278
9	.036	.080	.426	-.221
10	-.023	.066	.259	-.293

DATA FOR PROJECT 6022 CONFIG. S WIND DIR. 113 TUBING NO. 1				
TAP	MEAN	RMS	MAX	MIN
1	-.028	.047	.208	-.188
2	-.027	.048	.251	-.192
3	-.022	.055	.247	-.314
4	-.006	.055	.306	-.272
5	.000	.057	.305	-.245
6	.008	.062	.318	-.233
7	.016	.067	.389	-.326
8	.003	.075	.414	-.314
9	.017	.082	.422	-.366
10	.009	.110	.491	-.677

DATA FOR PROJECT 6022 CONFIG. S WIND DIR. 123 TUBING NO. 1				
TAP	MEAN	RMS	MAX	MIN
1	-.003	.080	.367	-.302
2	.008	.082	.424	-.267
3	.035	.084	.485	-.218
4	.047	.091	.587	-.216
5	.078	.106	.604	-.237
6	.072	.109	.590	-.238
7	.067	.101	.518	-.291
8	.035	.092	.545	-.273
9	.006	.074	.318	-.220
10	-.049	.060	.204	-.293

DATA FOR PROJECT 6022 CONFIG. S WIND DIR. 211 TUBING NO. 1				
TAP	MEAN	RMS	MAX	MIN
1	-.017	.078	.290	-.316
2	.038	.084	.396	-.240
3	.096	.091	.493	-.198
4	.137	.096	.536	-.208
5	.159	.098	.554	-.157
6	.163	.103	.597	-.247
7	.186	.115	.600	-.236
8	.219	.129	.646	-.232
9	.255	.148	.739	-.250
10	.292	.182	.863	-.402

DATA FOR PROJECT 6022 CONFIG. S					WIND DIR. 221 TUBING NO. 1				
TAP	MEAN	RMS	MAX	MIN	TAP	MEAN	RMS	MAX	MIN
1	.401	.133	.924	-.047	11	-.621	.142	-.169	-1.222
2	.437	.135	.852	-.087	12	-.624	.134	-.248	-1.316
3	.463	.131	.927	-.033	13	-.609	.118	-.269	-1.069
4	.452	.131	.940	-.011	14	-.632	.112	-.368	-1.046
5	.432	.126	.904	-.003	15	-.660	.122	-.282	-1.135
6	.366	.118	.612	-.097	16	-.710	.144	-.289	-1.289
7	.280	.101	.699	-.114	17	-.675	.153	-.175	-1.287
8	.165	.086	.489	-.154	18	-.726	.172	-.200	-1.608
9	.041	.074	.354	-.221	19	-.715	.169	-.270	-1.551
10	-.160	.076	.144	-.464	20	-.733	.170	-.279	-1.595

DATA FOR PROJECT 6022 CONFIG. S					WIND DIR. 311 TUBING NO. 1				
TAP	MEAN	RMS	MAX	MIN	TAP	MEAN	RMS	MAX	MIN
1	-.131	.041	.010	-.272	11	-.409	.076	-.169	-.685
2	-.117	.041	.029	-.260	12	-.395	.072	-.179	-.771
3	-.102	.041	.033	-.242	13	-.362	.065	-.158	-.617
4	-.095	.041	.066	-.242	14	-.319	.061	-.132	-.519
5	-.080	.043	.091	-.233	15	-.284	.051	-.103	-.482
6	-.078	.044	.103	-.230	16	-.266	.054	-.093	-.476
7	-.069	.049	.137	-.230	17	-.248	.047	-.076	-.426
8	-.072	.051	.095	-.252	18	-.237	.045	-.092	-.421
9	-.064	.055	.114	-.249	19	-.229	.045	-.092	-.414
10	-.069	.065	.133	-.307	20	-.233	.048	-.093	-.503

DATA FOR PROJECT 6022 CONFIG. S					WIND DIR. 321 TUBING NO. 1				
TAP	MEAN	RMS	MAX	MIN	TAP	MEAN	RMS	MAX	MIN
1	-.100	.047	.068	-.263	11	-.266	.044	-.134	-.432
2	-.092	.046	.078	-.267	12	-.270	.043	-.125	-.418
3	-.081	.046	.071	-.277	13	-.272	.041	-.125	-.444
4	-.075	.047	.086	-.271	14	-.267	.041	-.115	-.414
5	-.063	.047	.126	-.205	15	-.260	.042	-.098	-.413
6	-.061	.050	.105	-.221	16	-.263	.043	-.121	-.408
7	-.057	.053	.130	-.254	17	-.259	.047	-.101	-.426
8	-.073	.054	.129	-.278	18	-.259	.041	-.113	-.401
9	-.099	.055	.099	-.288	19	-.256	.042	-.121	-.416
10	-.148	.056	.029	-.352	20	-.261	.042	-.125	-.421

DATA FOR PROJECT 6022 CONFIG. T					WIND DIR. 11 TUBING NO. 1				
TAP	MEAN	RMS	MAX	MIN	TAP	MEAN	RMS	MAX	MIN
1	-.121	.075	.183	-.448	11	-.567	.305	.146	-2.399
2	-.100	.082	.270	-.587	12	-.426	.188	.140	-1.374
3	-.085	.092	.350	-.365	13	-.387	.150	.150	-1.159
4	-.054	.098	.427	-.364	14	-.391	.156	.128	-1.169
5	-.022	.096	.430	-.367	15	-.348	.128	.134	-.967
6	-.016	.106	.438	-.448	16	-.317	.113	.137	-.931
7	-.000	.116	.525	-.427	17	-.303	.098	.019	-.937
8	.027	.126	.560	-.444	18	-.300	.094	-.001	-.914
9	.049	.125	.649	-.383	19	-.286	.095	-.006	-.734
10	.028	.155	.792	-.663	20	-.275	.102	.026	-1.028

DATA FOR PROJECT 6022 CONFIG. T					WIND DIR. 21 TUBING NO. 1				
TAP	MEAN	RMS	MAX	MIN	TAP	MEAN	RMS	MAX	MIN
1	.114	.130	.843	-.293	11	-.314	.094	-.060	-.860
2	.137	.130	.924	-.228	12	-.320	.090	-.071	-.767
3	.130	.134	.990	-.297	13	-.333	.085	-.086	-.692
4	.142	.143	.995	-.350	14	-.331	.086	-.076	-.694
5	.160	.145	.853	-.205	15	-.362	.094	-.041	-.798
6	.175	.150	.851	-.241	16	-.380	.107	-.062	-.882
7	.150	.143	.685	-.352	17	-.366	.118	-.066	-.928
8	.119	.136	.621	-.252	18	-.346	.124	-.007	-1.004
9	.066	.121	.504	-.337	19	-.358	.122	-.018	-1.100
10	-.026	.100	.336	-.373	20	-.359	.125	-.006	-1.174

DATA FOR PROJECT 6022 CONFIG. T					WIND DIR. 12 TUBING NO. 1				
TAP	MEAN	RMS	MAX	MIN	TAP	MEAN	RMS	MAX	MIN
1	-.136	.080	.272	-.488	11	-1.082	.535	.105	-3.406
2	-.107	.088	.286	-.489	12	-.452	.182	.135	-1.532
3	-.077	.096	.312	-.490	13	-.416	.146	.012	-1.291
4	-.054	.103	.401	-.483	14	-.476	.188	.025	-1.460
5	-.015	.106	.464	-.430	15	-.485	.180	.086	-1.325
6	-.004	.115	.506	-.509	16	-.406	.158	.131	-1.154
7	.035	.134	.505	-.520	17	-.349	.139	.084	-1.061
8	.068	.144	.607	-.527	18	-.328	.125	.099	-1.040
9	.117	.148	.682	-.511	19	-.299	.122	.187	-1.357
10	.142	.184	.783	-.626	20	-.289	.119	.158	-.918

DATA FOR PROJECT 6022 CONFIG. T WIND DIR. 22 TUBING NO. 1				
TAP	MEAN	RMS	MAX	MIN
1	.168	.140	.783	-.440
2	.208	.142	.773	-.701
3	.216	.143	.802	-.506
4	.234	.148	.829	-.375
5	.270	.141	.847	-.102
6	.280	.144	.949	-.183
7	.247	.132	.727	-.199
8	.204	.121	.670	-.224
9	.136	.110	.585	-.226
10	.024	.089	.401	-.339

DATA FOR PROJECT 6022 CONFIG. T WIND DIR. 13 TUBING NO. 1				
TAP	MEAN	RMS	MAX	MIN
1	-.093	.061	.164	-.298
2	-.074	.063	.191	-.333
3	-.063	.064	.222	-.448
4	-.056	.069	.224	-.509
5	-.047	.074	.267	-.543
6	-.032	.080	.340	-.479
7	-.023	.097	.397	-.379
8	-.009	.107	.449	-.419
9	.016	.114	.506	-.459
10	.019	.149	.646	-.901

DATA FOR PROJECT 6022 CONFIG. T WIND DIR. 23 TUBING NO. 1				
TAP	MEAN	RMS	MAX	MIN
1	.047	.117	.843	-.293
2	.073	.119	.819	-.230
3	.075	.122	.906	-.244
4	.094	.130	.768	-.350
5	.114	.135	.820	-.314
6	.130	.143	.843	-.260
7	.113	.139	.777	-.221
8	.096	.130	.652	-.296
9	.052	.112	.547	-.295
10	-.011	.091	.371	-.321

DATA FOR PROJECT 6022 CONFIG. T WIND DIR. 14 TUBING NO. 1				
TAP	MEAN	RMS	MAX	MIN
1	-.167	.060	.040	-.433
2	-.144	.061	.089	-.378
3	-.135	.060	.206	-.404
4	-.126	.067	.133	-.489
5	-.113	.073	.267	-.433
6	-.103	.081	.293	-.513
7	-.098	.088	.240	-.514
8	-.104	.103	.307	-.506
9	-.095	.111	.378	-.504
10	-.105	.128	.439	-.797

DATA FOR PROJECT 6022 CONFIG. T WIND DIR. 24 TUBING NO. 1				
TAP	MEAN	RMS	MAX	MIN
1	.073	.121	.759	-.352
2	.085	.117	.686	-.316
3	.085	.116	.742	-.296
4	.097	.122	.678	-.251
5	.104	.134	.699	-.267
6	.128	.151	.838	-.372
7	.128	.152	.854	-.346
8	.109	.147	.664	-.281
9	.057	.139	.607	-.328
10	-.052	.114	.425	-.501

DATA FOR PROJECT 6022 CONFIG. T WIND DIR. 111 TUBING NO. 1				
TAP	MEAN	RMS	MAX	MIN
1	-.021	.067	.284	-.331
2	-.003	.069	.296	-.291
3	.014	.082	.364	-.255
4	.038	.085	.526	-.269
5	.046	.085	.410	-.289
6	.034	.088	.464	-.293
7	.017	.092	.591	-.278
8	.020	.101	.750	-.426
9	.018	.109	.647	-.522
10	.015	.140	.648	-.556

DATA FOR PROJECT 6022 CONFIG. T WIND DIR. 121 TUBING NO. 1										
TAP	MEAN	RMS	MAX	MIN	TAP	MEAN	RMS	MAX	MIN	
1	.163	.114	.639	-.161	11	-.192	.060	.053	-.504	
2	.193	.118	.688	-.150	12	-.207	.061	.023	-.489	
3	.214	.120	.694	-.154	13	-.228	.060	.001	-.453	
4	.227	.126	.771	-.160	14	-.246	.062	.030	-.534	
5	.213	.119	.739	-.101	15	-.259	.065	.062	-.524	
6	.187	.115	.688	-.138	16	-.271	.080	.054	-.635	
7	.137	.100	.555	-.154	17	-.286	.122	.027	-.973	
8	.091	.089	.482	-.172	18	-.284	.152	.081	-1.187	
9	.036	.077	.351	-.269	19	-.284	.155	.125	-1.304	
10	-.040	.065	.238	-.307	20	-.292	.169	.161	-1.696	

DATA FOR PROJECT 6022 CONFIG. T WIND DIR. 112 TUBING NO. 1										
TAP	MEAN	RMS	MAX	MIN	TAP	MEAN	RMS	MAX	MIN	
1	.021	.066	.268	-.201	11	-.428	.176	.123	-1.339	
2	.029	.067	.299	-.192	12	-.401	.171	.113	-1.373	
3	.040	.073	.327	-.213	13	-.394	.168	.141	-1.270	
4	.052	.075	.343	-.244	14	-.321	.150	.112	-1.178	
5	.058	.076	.371	-.197	15	-.179	.111	.107	-.976	
6	.050	.081	.352	-.208	16	-.112	.083	.163	-.691	
7	.042	.092	.486	-.321	17	-.083	.069	.236	-.440	
8	.057	.100	.577	-.355	18	-.069	.069	.230	-.420	
9	.071	.107	.649	-.399	19	-.061	.072	.211	-.416	
10	.068	.138	.860	-.643	20	-.048	.075	.212	-.617	

DATA FOR PROJECT 6022 CONFIG. T WIND DIR. 122 TUBING NO. 1										
TAP	MEAN	RMS	MAX	MIN	TAP	MEAN	RMS	MAX	MIN	
1	.078	.105	.622	-.270	11	-.138	.059	.091	-.382	
2	.122	.106	.607	-.202	12	-.150	.062	.098	-.403	
3	.136	.105	.629	-.188	13	-.179	.064	.052	-.436	
4	.153	.108	.694	-.208	14	-.186	.066	.053	-.456	
5	.167	.110	.703	-.139	15	-.225	.067	.030	-.544	
6	.168	.107	.670	-.214	16	-.261	.074	.063	-.655	
7	.131	.095	.628	-.176	17	-.286	.100	.009	-.933	
8	.092	.088	.520	-.231	18	-.276	.124	.040	-1.282	
9	.050	.077	.463	-.229	19	-.283	.134	.034	-1.288	
10	-.003	.065	.328	-.243	20	-.296	.152	.131	-1.657	

DATA FOR PROJECT 6022 CONFIG. T WIND DIR. 113 TUBING NO. 1										
TAP	MEAN	RMS	MAX	MIN	TAP	MEAN	RMS	MAX	MIN	
1	-.017	.051	.186	-.191	11	-.226	.133	.157	-1.266	
2	-.012	.051	.207	-.238	12	-.220	.129	.162	-1.141	
3	-.009	.057	.232	-.171	13	-.202	.119	.167	-1.076	
4	-.006	.058	.256	-.226	14	-.177	.105	.127	-.929	
5	-.007	.060	.265	-.195	15	-.136	.079	.114	-.689	
6	-.003	.065	.292	-.331	16	-.103	.070	.199	-.451	
7	-.006	.069	.244	-.358	17	-.077	.063	.233	-.372	
8	-.004	.077	.317	-.312	18	-.068	.062	.232	-.391	
9	-.010	.083	.332	-.380	19	-.069	.060	.145	-.361	
10	-.002	.109	.484	-.732	20	-.071	.064	.141	-.369	

DATA FOR PROJECT 6022 CONFIG. T WIND DIR. 123 TUBING NO. 1										
TAP	MEAN	RMS	MAX	MIN	TAP	MEAN	RMS	MAX	MIN	
1	.007	.088	.473	-.220	11	-.092	.046	.110	-.260	
2	.044	.089	.614	-.204	12	-.098	.046	.097	-.249	
3	.047	.093	.649	-.184	13	-.112	.050	.076	-.346	
4	.062	.099	.596	-.183	14	-.101	.051	.118	-.332	
5	.093	.103	.562	-.212	15	-.123	.054	.034	-.389	
6	.108	.103	.573	-.192	16	-.156	.062	.019	-.557	
7	.080	.095	.541	-.244	17	-.181	.069	.044	-.548	
8	.056	.088	.468	-.240	18	-.164	.079	.073	-.812	
9	.027	.079	.469	-.204	19	-.173	.085	.078	-.928	
10	-.001	.065	.342	-.237	20	-.185	.096	.118	-.949	

DATA FOR PROJECT 6022 CONFIG. T WIND DIR. 211 TUBING NO. 1										
TAP	MEAN	RMS	MAX	MIN	TAP	MEAN	RMS	MAX	MIN	
1	-.060	.081	.259	-.391	11	-.485	.229	.063	-1.697	
2	-.013	.088	.377	-.311	12	-.419	.189	.194	-1.369	
3	-.002	.091	.349	-.265	13	-.348	.148	.182	-1.177	
4	.044	.109	.638	-.261	14	-.307	.124	.164	-.967	
5	.056	.109	.508	-.307	15	-.302	.105	.039	-.816	
6	.048	.104	.627	-.300	16	-.293	.087	.014	-.713	
7	.030	.107	.574	-.538	17	-.272	.076	.017	-.625	
8	.027	.113	.603	-.371	18	-.249	.072	.003	-.539	
9	.030	.118	.619	-.412	19	-.241	.076	.103	-.578	
10	.014	.142	.613	-.653	20	-.240	.080	.018	-.699	

DATA FOR PROJECT 6022 CONFIG. T WIND DIR. 221 TUBING NO. 1				
TAP	MEAN	RMS	MAX	MIN
1	.167	.145	.776	-.305
2	.222	.160	.868	-.250
3	.271	.160	.900	-.130
4	.279	.162	.948	-.138
5	.299	.141	.934	-.144
6	.249	.140	.742	-.178
7	.204	.125	.670	-.180
8	.123	.113	.525	-.235
9	.045	.100	.414	-.277
10	-.086	.083	.271	-.390

DATA FOR PROJECT 6022 CONFIG. T WIND DIR. 311 TUBING NO. 1				
TAP	MEAN	RMS	MAX	MIN
1	-.113	.043	.104	-.249
2	-.100	.044	.092	-.232
3	-.093	.041	.044	-.225
4	-.094	.042	.067	-.228
5	-.075	.043	.057	-.215
6	-.079	.044	.071	-.215
7	-.080	.047	.080	-.242
8	-.093	.049	.111	-.306
9	-.097	.051	.094	-.336
10	-.132	.058	.095	-.405

DATA FOR PROJECT 6022 CONFIG. T WIND DIR. 321 TUBING NO. 1				
TAP	MEAN	RMS	MAX	MIN
1	-.152	.041	.012	-.310
2	-.142	.042	.014	-.271
3	-.138	.043	.025	-.275
4	-.133	.045	.033	-.310
5	-.125	.048	.062	-.291
6	-.115	.050	.069	-.290
7	-.116	.052	.079	-.296
8	-.126	.053	.074	-.276
9	-.150	.054	.055	-.251
10	-.180	.054	.000	-.413

DATA FOR PROJECT 6022 CONFIG. U WIND DIR. 35 TUBING NO. 1				
TAP	MEAN	RMS	MAX	MIN
1	-.007	.074	.216	-.306
2	.120	.068	.390	-.138
3	.207	.077	.503	-.034
4	.282	.088	.610	.007
5	.352	.096	.754	.081
6	.398	.108	.846	.073
7	.449	.123	.961	.109
8	.485	.136	.973	.124
9	.509	.146	1.025	.132
10	.471	.170	1.070	.004

DATA FOR PROJECT 6022 CONFIG. U WIND DIR. 36 TUBING NO. 1				
TAP	MEAN	RMS	MAX	MIN
1	.009	.062	.234	-.241
2	.117	.061	.380	-.084
3	.192	.069	.505	-.048
4	.259	.078	.598	.014
5	.322	.085	.647	.056
6	.361	.095	.722	.085
7	.412	.115	.859	.092
8	.439	.126	1.008	.076
9	.459	.135	1.043	.096
10	.429	.159	1.087	-.036

DATA FOR PROJECT 6022 CONFIG. U WIND DIR. 37 TUBING NO. 1				
TAP	MEAN	RMS	MAX	MIN
1	-.003	.057	.190	-.223
2	.106	.056	.305	-.092
3	.190	.071	.540	-.022
4	.253	.082	.645	.020
5	.324	.089	.751	.053
6	.359	.100	.829	.061
7	.391	.102	.754	.087
8	.415	.113	.806	.075
9	.443	.120	.875	.085
10	.409	.146	1.018	-.050

DATA FOR PROJECT 6022 CONFIG. U WIND DIR. 145 TUBING NO. 1

TAP	MEAN	RMS	MAX	MIN	TAP	MEAN	RMS	MAX	MIN
1	.416	.135	.968	.090	11	-.539	.146	-.0558	-1.286
2	.420	.126	.926	.100	12	-.572	.147	-.0900	-1.364
3	.388	.120	.899	.080	13	-.600	.170	-.2222	-1.354
4	.367	.117	.833	.064	14	-.626	.182	-.2222	-1.537
5	.331	.122	.751	.074	15	-.742	.211	-.2800	-1.636
6	.313	.117	.779	.020	16	-.879	.243	-.3111	-2.176
7	.243	.105	.666	-.012	17	-.849	.240	-.193	-2.018
8	.173	.093	.514	-.076	18	-.652	.238	-.171	-1.836
9	.079	.077	.399	-.183	19	-1.089	.510	-.153	-3.176
10	-.073	.068	.157	-.349	20	-1.918	.494	-.710	-4.085

DATA FOR PROJECT 6022 CONFIG. U WIND DIR. 146 TUBING NO. 1

TAP	MEAN	RMS	MAX	MIN	TAP	MEAN	RMS	MAX	MIN
1	.379	.141	.997	.026	11	-.581	.162	-.125	-1.560
2	.395	.133	.919	.078	12	-.603	.162	-.135	-1.578
3	.372	.127	.866	.084	13	-.653	.165	-.225	-1.294
4	.361	.124	.870	.058	14	-.670	.175	-.214	-1.347
5	.349	.127	.847	.008	15	-.784	.199	-.251	-1.610
6	.329	.121	.773	-.004	16	-.912	.226	-.349	-2.029
7	.253	.110	.664	-.058	17	-.983	.251	-.262	-1.911
8	.180	.098	.564	-.108	18	-.795	.288	-.139	-2.315
9	.071	.082	.418	-.199	19	-1.129	.443	-.241	-2.899
10	-.089	.075	.183	-.391	20	-1.676	.474	-.566	-3.438

DATA FOR PROJECT 6022 CONFIG. U WIND DIR. 147 TUBING NO. 1

TAP	MEAN	RMS	MAX	MIN	TAP	MEAN	RMS	MAX	MIN
1	.372	.146	.969	.023	11	-.592	.155	-.161	-1.485
2	.383	.140	.943	.044	12	-.606	.155	-.181	-1.599
3	.366	.135	.915	.038	13	-.691	.173	-.198	-1.465
4	.358	.132	.875	.041	14	-.716	.182	-.232	-1.540
5	.338	.121	.866	.055	15	-.828	.208	-.257	-1.727
6	.312	.115	.865	-.034	16	-.955	.238	-.336	-1.933
7	.239	.103	.670	-.022	17	-.967	.245	-.358	-2.166
8	.166	.091	.571	-.127	18	-.813	.295	-.136	-2.269
9	.058	.077	.354	-.155	19	-1.126	.448	-.135	-2.902
10	-.107	.068	.119	-.365	20	-1.660	.489	-.451	-4.356

DATA FOR PROJECT 6022 CONFIG. V WIND DIR. 35 TUBING NO. 1

TAP	MEAN	RMS	MAX	MIN	TAP	MEAN	RMS	MAX	MIN
1	.154	.064	.458	-.069	11	-.827	.225	-.111	-1.743
2	.187	.065	.478	-.025	12	-.878	.232	-.171	-2.058
3	.223	.072	.518	-.040	13	-1.009	.254	-.287	-2.126
4	.258	.076	.576	-.002	14	-.962	.299	-.001	-2.136
5	.285	.080	.622	-.025	15	-.416	.296	-.204	-1.574
6	.303	.089	.690	.019	16	-.132	.194	.370	-1.020
7	.325	.100	.826	.074	17	-.033	.123	.439	-.857
8	.351	.112	.960	.047	18	-.006	.108	.386	-.677
9	.358	.123	.946	.048	19	.011	.104	.609	-.418
10	.304	.146	1.066	-.105	20	.016	.101	.552	-.503

DATA FOR PROJECT 6022 CONFIG. V WIND DIR. 36 TUBING NO. 1

TAP	MEAN	RMS	MAX	MIN	TAP	MEAN	RMS	MAX	MIN
1	.114	.060	.423	-.098	11	-.432	.144	-.049	-1.027
2	.148	.063	.435	-.079	12	-.451	.143	-.088	-.961
3	.186	.074	.468	-.261	13	-.477	.147	-.122	-1.068
4	.225	.086	.585	-.178	14	-.480	.150	-.079	-1.057
5	.260	.085	.654	-.162	15	-.485	.147	.031	-1.127
6	.266	.092	.700	-.054	16	-.242	.150	.208	-.863
7	.283	.097	.672	-.173	17	-.134	.127	.407	-.893
8	.284	.107	.716	-.116	18	-.092	.114	.394	-.870
9	.274	.114	.698	-.150	19	-.067	.098	.287	-.534
10	.211	.135	.789	-.258	20	-.051	.095	.327	-.453

DATA FOR PROJECT 6022 CONFIG. V WIND DIR. 37 TUBING NO. 1

TAP	MEAN	RMS	MAX	MIN	TAP	MEAN	RMS	MAX	MIN
1	.096	.059	.302	-.135	11	-.470	.141	-.005	-1.368
2	.129	.060	.354	-.141	12	-.467	.140	-.022	-1.592
3	.166	.065	.478	-.080	13	-.494	.141	-.092	-1.328
4	.209	.070	.517	-.082	14	-.502	.146	-.065	-1.095
5	.235	.074	.563	-.049	15	-.387	.137	.019	-.959
6	.247	.082	.594	-.069	16	-.230	.141	.155	-.890
7	.265	.094	.686	-.087	17	-.134	.121	.181	-.833
8	.273	.103	.719	-.110	18	-.093	.107	.298	-.668
9	.270	.108	.719	-.112	19	-.084	.101	.297	-.570
10	.213	.129	.817	-.169	20	-.063	.098	.348	-.552

DATA FOR PROJECT 6022 CONFIG. V WIND DIR. 145 TUBING NO. 1

TAP	MEAN	RMS	MAX	MIN	TAP	MEAN	RMS	MAX	MIN
1	.382	.131	.902	-.017	11	-.103	.067	.146	-.401
2	.369	.122	.919	-.048	12	-.114	.073	.162	-.535
3	.344	.111	.872	-.045	13	-.140	.093	.200	-.722
4	.308	.103	.801	-.029	14	-.187	.125	.072	-1.009
5	.240	.085	.545	-.017	15	-.323	.196	.031	-1.166
6	.192	.077	.501	-.017	16	-.609	.238	-.065	-1.464
7	.143	.065	.407	-.049	17	-.818	.185	-.311	-1.804
8	.094	.058	.308	-.090	18	-.760	.167	-.328	-1.503
9	.053	.056	.354	-.134	19	-.702	.155	-.318	-1.432
10	-.018	.053	.218	-.214	20	-.692	.160	-.253	-1.586

DATA FOR PROJECT 6022 CONFIG. V WIND DIR. 146 TUBING NO. 1

TAP	MEAN	RMS	MAX	MIN	TAP	MEAN	RMS	MAX	MIN
1	.217	.106	.680	-.065	11	-.135	.074	.118	-.679
2	.229	.106	.698	-.046	12	-.153	.077	.115	-.677
3	.243	.102	.674	-.015	13	-.150	.080	.097	-.539
4	.234	.102	.654	-.022	14	-.191	.097	.113	-.753
5	.235	.093	.551	-.020	15	-.273	.142	.010	-1.005
6	.196	.090	.509	-.042	16	-.486	.178	-.085	-1.192
7	.154	.078	.517	-.047	17	-.657	.154	-.255	-1.402
8	.094	.069	.351	-.089	18	-.656	.154	-.257	-1.409
9	.052	.059	.283	-.178	19	-.598	.144	-.228	-1.343
10	-.039	.054	.172	-.261	20	-.607	.154	-.176	-1.320

DATA FOR PROJECT 6022 CONFIG. V WIND DIR. 147 TUBING NO. 1

TAP	MEAN	RMS	MAX	MIN	TAP	MEAN	RMS	MAX	MIN
1	.213	.107	.644	-.117	11	-.142	.073	.106	-.483
2	.223	.107	.668	-.076	12	-.152	.076	.068	-.451
3	.243	.103	.682	-.046	13	-.168	.083	.149	-.544
4	.233	.103	.674	-.047	14	-.215	.098	.060	-.794
5	.237	.097	.644	-.044	15	-.312	.153	.058	-1.000
6	.190	.092	.613	-.088	16	-.564	.201	-.014	-1.275
7	.146	.077	.474	-.119	17	-.720	.164	-.262	-1.619
8	.087	.069	.394	-.154	18	-.722	.160	-.298	-1.957
9	.042	.060	.290	-.133	19	-.657	.151	-.259	-1.548
10	-.052	.054	.214	-.244	20	-.667	.160	-.199	-1.650

DATA FOR PROJECT 6022 CONFIG. W WIND DIR. 35 TUBING NO. 1

TAP	MEAN	RMS	MAX	MIN	TAP	MEAN	RMS	MAX	MIN
1	-.336	.071	-.126	-.784	11	1.124	.053	1.245	.977
2	-.358	.073	-.138	-.849	12	1.125	.059	1.259	.965
3	-.302	.065	-.107	-.544	13	1.126	.055	1.252	.974
4	-.450	.074	-.244	-.741	14	1.126	.057	1.252	.954
5	-.376	.072	-.198	-.681	15	1.279	.045	1.394	1.116
6	-.395	.074	-.170	-.711	16	1.305	.049	1.418	1.124
7	-.358	.075	-.126	-.792	17	1.288	.048	1.406	1.118
8	-.487	.086	-.197	-.911	18	1.292	.049	1.421	1.124
9	-.167	.064	-.080	-.383	19	-.281	.066	-.097	-.604
10	-.087	.064	.159	-.287	20	-.414	.074	-.210	-.775

DATA FOR PROJECT 6022 CONFIG. W WIND DIR. 36 TUBING NO. 1

TAP	MEAN	RMS	MAX	MIN	TAP	MEAN	RMS	MAX	MIN
1	-.273	.194	.218	-1.558	11	1.116	.026	1.191	1.021
2	-.237	.166	.284	-1.496	12	1.118	.030	1.213	1.010
3	-.167	.131	.376	-.845	13	.470	.116	.705	.287
4	-.251	.128	.193	-.872	14	1.115	.028	1.186	1.020
5	-.164	.108	.125	-.746	15	1.289	.051	1.406	1.134
6	-.155	.098	.166	-.594	16	1.316	.056	1.455	1.150
7	-.109	.098	.229	-.630	17	1.297	.053	1.436	1.146
8	-.204	.107	.120	-.872	18	1.294	.053	1.436	1.139
9	-.034	.103	.438	-.409	19	-.417	.294	.275	-1.999
10	-.020	.110	.640	-.333	20	-.442	.272	.247	-1.673

DATA FOR PROJECT 6022 CONFIG. W WIND DIR. 37 TUBING NO. 1

TAP	MEAN	RMS	MAX	MIN	TAP	MEAN	RMS	MAX	MIN
1	-.165	.399	.288	-1.434	11	-.362	.244	.181	-1.635
2	-.012	.096	.329	-.568	12	-.368	.247	.145	-1.593
3	-.385	.252	.181	-1.657	13	-.302	.201	.221	-1.501
4	-.388	.254	.133	-2.118	14	-.240	.159	.238	-1.136
5	-.313	.196	.131	-1.311	15	-.200	.132	.215	-1.312
6	-.239	.154	.136	-1.488	16	-.187	.119	.156	-1.535
7	1.115	.037	1.206	.950	17	-.151	.104	.165	-.763
8	1.109	.037	1.206	.938	18	-.130	.097	.193	-.602
9	1.117	.038	1.216	.936	19	-.147	.128	.159	-.044
10	1.117	.037	1.214	.942	20	-.148	.128	.156	-1.430

DATA FOR PROJECT 6022 CONFIG. W WIND DIR. 145 TUBING NO. 1				
TAP	MEAN	RMS	MAX	MIN
1	.383	.103	.722	.101
2	.325	.090	.632	.069
3	.257	.081	.561	.032
4	.150	.077	.456	.068
5	.153	.068	.396	.052
6	.100	.063	.361	.077
7	.021	.054	.235	.162
8	.094	.053	.096	.297
9	.093	.056	.152	.286
10	.161	.054	.069	.338

DATA FOR PROJECT 6022 CONFIG. W WIND DIR. 146 TUBING NO. 1				
TAP	MEAN	RMS	MAX	MIN
1	.046	.118	.289	.732
2	.055	.090	.247	.389
3	.075	.084	.330	.386
4	.127	.083	.345	.512
5	.057	.079	.452	.535
6	.038	.082	.535	.389
7	.047	.095	.635	.386
8	.101	.106	.581	.462
9	.054	.099	.556	.419
10	.070	.092	.619	.521

DATA FOR PROJECT 6022 CONFIG. W WIND DIR. 147 TUBING NO. 1				
TAP	MEAN	RMS	MAX	MIN
1	.161	.139	.729	.689
2	.130	.114	.558	.291
3	.087	.100	.462	.267
4	.041	.093	.440	.334
5	.051	.090	.454	.276
6	.037	.087	.414	.269
7	.013	.088	.408	.513
8	.012	.082	.352	.500
9	.007	.079	.359	.403
10	.035	.070	.282	.412

DATA FOR PROJECT 6022 CONFIG. X WIND DIR. 35 TUBING NO. 1				
TAP	MEAN	RMS	MAX	MIN
1	.224	.094	.099	.614
2	.221	.083	.198	.641
3	.183	.080	.058	.578
4	.270	.084	.005	.776
5	.182	.072	.054	.456
6	.178	.068	.058	.408
7	.147	.061	.058	.414
8	.255	.078	.032	.640
9	.150	.049	.020	.309
10	.145	.050	.023	.303

DATA FOR PROJECT 6022 CONFIG. X WIND DIR. 36 TUBING NO. 1				
TAP	MEAN	RMS	MAX	MIN
1	.181	.125	.175	-1.256
2	.162	.099	.107	.751
3	.102	.081	.145	.780
4	.175	.082	.095	.797
5	.105	.069	.102	.420
6	.101	.066	.085	.429
7	.067	.067	.186	.424
8	.161	.076	.072	.740
9	.078	.052	.091	.337
10	.076	.052	.085	.301

DATA FOR PROJECT 6022 CONFIG. X WIND DIR. 145 TUBING NO. 1				
TAP	MEAN	RMS	MAX	MIN
1	.101	.041	.029	.250
2	.073	.040	.066	.226
3	.098	.041	.070	.295
4	.184	.047	.008	.389
5	.120	.047	.189	.356
6	.090	.055	.327	.326
7	.107	.066	.327	.453
8	.188	.075	.277	.636
9	.117	.074	.339	.460
10	.093	.068	.308	.457

B-55

DATA FOR PROJECT 6022 CONFIG. X					WIND DIR. 146 TUBING NO. 1				
TAP	MEAN	RMS	MAX	MIN	TAP	MEAN	RMS	MAX	MIN
1	.104	.044	.071	.277	11	.109	.043	.032	.262
2	.079	.046	.089	.264	12	.126	.044	.024	.352
3	.093	.050	.092	.313	13	.108	.041	.070	.343
4	.165	.056	.063	.386	14	.075	.039	.058	.302
5	.097	.061	.265	.462	15	.089	.039	.032	.342
6	.064	.068	.276	.274	16	.159	.040	.035	.349
7	.065	.077	.397	.333	17	.108	.037	.009	.237
8	.135	.086	.403	.485	18	.079	.036	.037	.232
9	.073	.086	.675	.329	19	.096	.037	.021	.232
10	.057	.074	.578	.326	20	.163	.040	.046	.342

DATA FOR PROJECT 6022 CONFIG. Z					WIND DIR. 35 TUBING NO. 1				
TAP	MEAN	RMS	MAX	MIN	TAP	MEAN	RMS	MAX	MIN
1	.202	.024	.116	.295	11	.707	.037	.565	.828
2	.011	.020	.083	.064	12	.714	.036	.585	.818
3	.160	.017	.241	.120	13	.713	.034	.589	.815
4	.318	.016	.372	.264	14	.713	.033	.591	.806
5	.456	.015	.509	.405	15	.714	.031	.622	.823
6	.581	.015	.640	.522	16	.726	.032	.637	.833
7	.729	.018	.785	.676	17	.724	.035	.603	.862
8	.651	.018	.902	.772	18	.721	.036	.615	.868
9	.942	.017	.994	.841	19	.712	.035	.561	.840
10	.973	.015	.018	.888	20	.719	.038	.543	.870

C-1

APPENDIX C

Plots of Pressure Distribution along Chord of Solar Array

LIST OF PLOTS

<u>Plot</u>	<u>Page</u>
1-1 Single Array, Uniform Flow Study Effects of Angle of Attack and Ground Clearance	C-3
1-2 Single Array, Nonuniform Flow Study Effects of Angle of Attack and Fence Height	C-9
2-1-1 Multiple Arrays without Fence, Uniform Flow Study Effect of Angle of Attack	C-11
2-1-2 Multiple Arrays without Fence, Uniform Flow Study Effect of Separation Distance	C-20
2-1-3 Multiple Arrays without Fence, Uniform Flow Study Effect of Array Position	C-31
2-2-1 Multiple Arrays without Fence, Nonuniform Flow Study Effect of Angle of Attack	C-39
2-2-2 Multiple Arrays without Fence, Nonuniform Flow Study Effect of Separation Distance	C-48
2-2-3 Multiple Arrays without Fence, Nonuniform Flow Study Effect of Array Position	C-59
3-1 Multiple Arrays with Fence, $WD = 0^\circ$ Effect of Angle of Attack.	C-67
3-2 Multiple Arrays with Fence, $WD = 0^\circ$ Effect of Array Position	C-72
3-3 Multiple Arrays with Fence, $WD = 0^\circ$ Effect of Fence Distance	C-78
3-4 Multiple Arrays with Fence, $WD = 0^\circ$ Effect of Fence Height	C-84
3-5 Multiple Arrays with Fence, $WD = 0^\circ$ Effect of Fence Porosity	C-92
4-1 Edge Study, $WD = 0^\circ$ Effect of Fence	C-93
5-1-1 Corner Study, $WD = 45^\circ$, Standard Model Effect of Array Position	C-96
5-1-2 Corner Study, $WD = 45^\circ$, Standard Model Effect of Fence Configuration	C-101
5-2-1 Corner Study, $WD = 45^\circ$, Modified Model with Solid Extension Effect of Array Position	C-104

<u>Plot</u>		<u>Page</u>
5-2-2	Corner Study, WD = 45°, Modified Model with Solid Extension Effect of Model Modification	C-108
5-2-3	Corner Study, WD = 45°, Modified Model with Solid Extension Effect of Fence Configuration	C-117
5-3-1	Corner Study, WD = 45°, Modified Model with Various Extension Effect of Array Position	C-120
5-3-2	Corner Study, WD = 45°, Modified Model with Various Extension Effect of Model Configuration	C-122

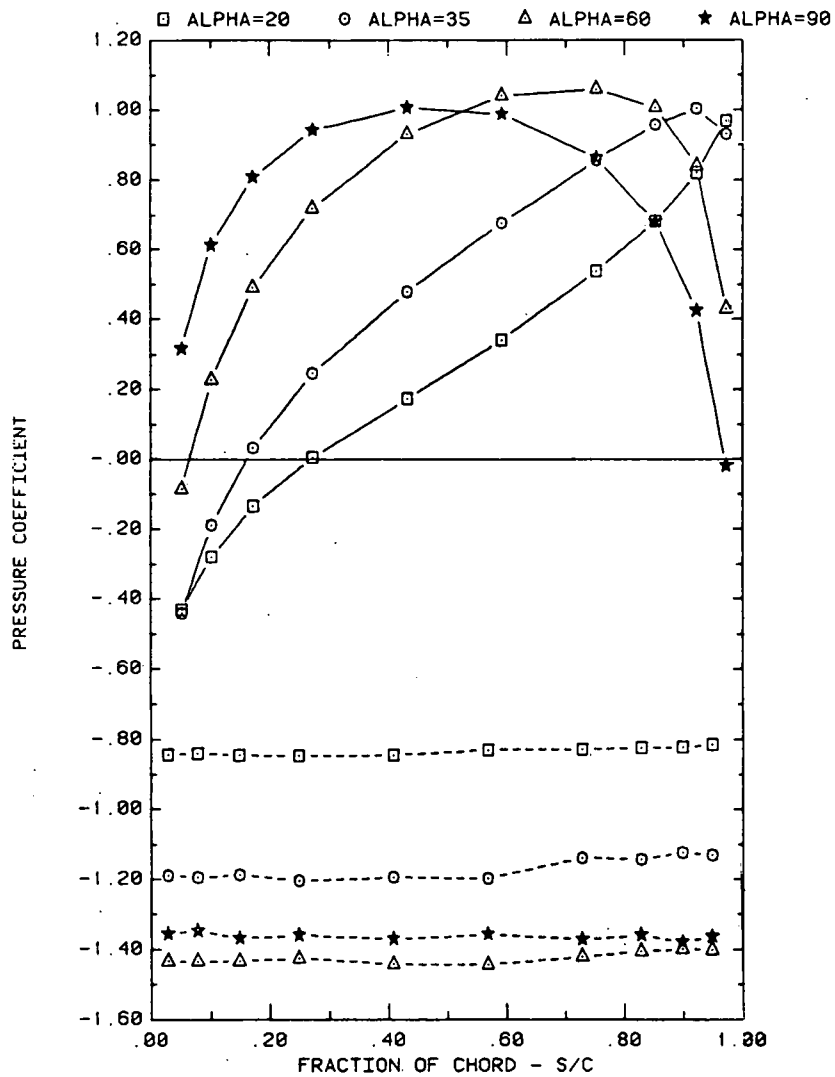

FRONT AND BACK PRESSURES ON A SINGLE ARRAY IN UNIFORM FLOW
EFFECT OF ATTACK ANGLE FOR GROUND CLEARANCE, H/C = INFINITY

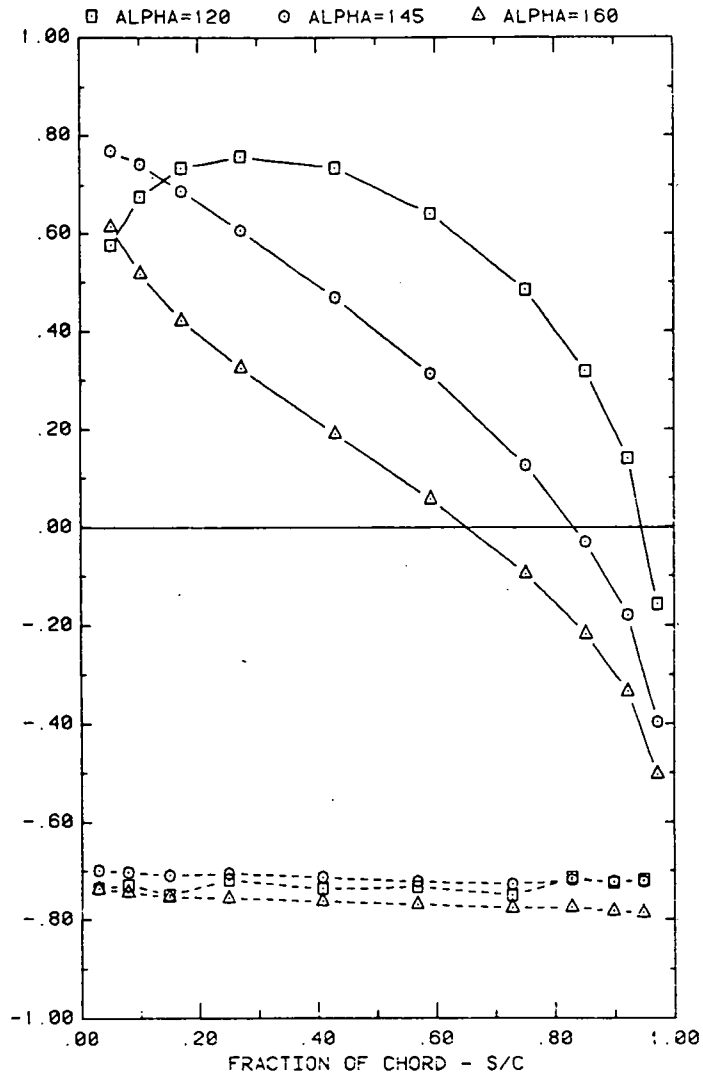

FRONT AND BACK PRESSURES ON A SINGLE ARRAY IN UNIFORM FLOW
EFFECT OF ATTACK ANGLE FOR GROUND CLEARANCE, H/C = 0.25

Plot 1-1. Single Array, Uniform Flow Study Effects of Angle of Attack and Ground Clearance

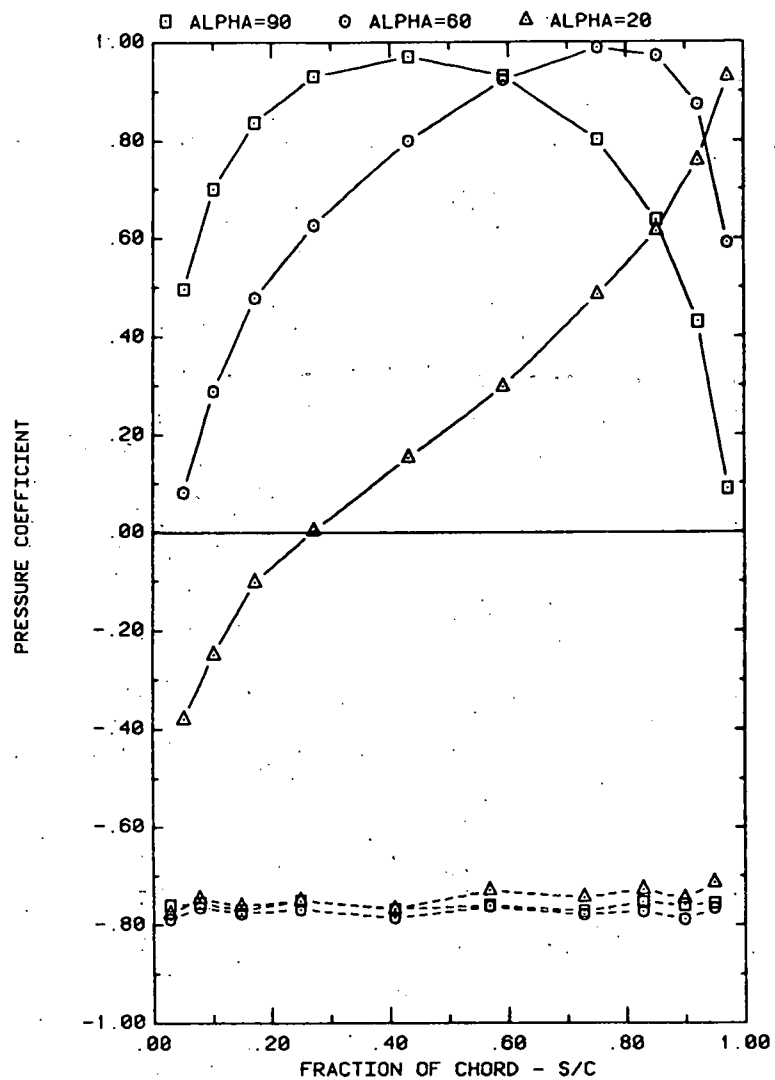

FRONT AND BACK PRESSURES ON A SINGLE ARRAY IN UNIFORM FLOW
EFFECT OF ATTACK ANGLE FOR GROUND CLEARANCE, $h/c = 0.50$

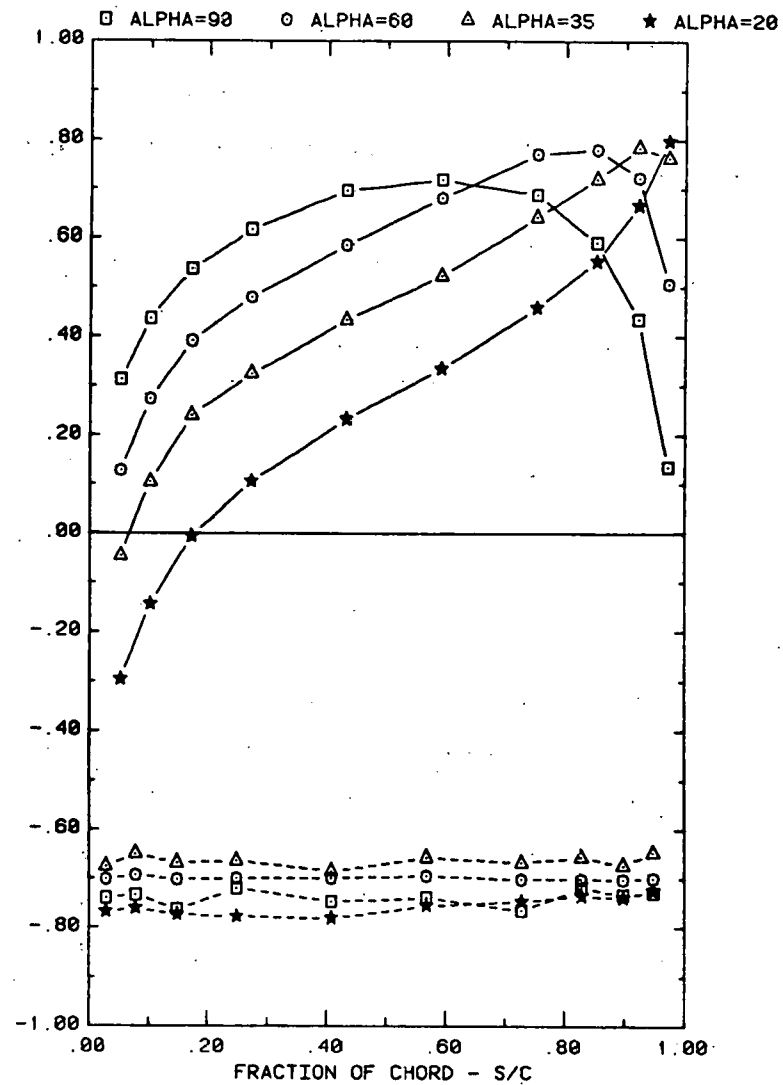

FRONT AND BACK PRESSURES ON A SINGLE ARRAY IN UNIFORM FLOW
EFFECT OF ATTACK ANGLE FOR GROUND CLEARANCE, $h/c = 0.25$

Plot 1-1. (Continued)

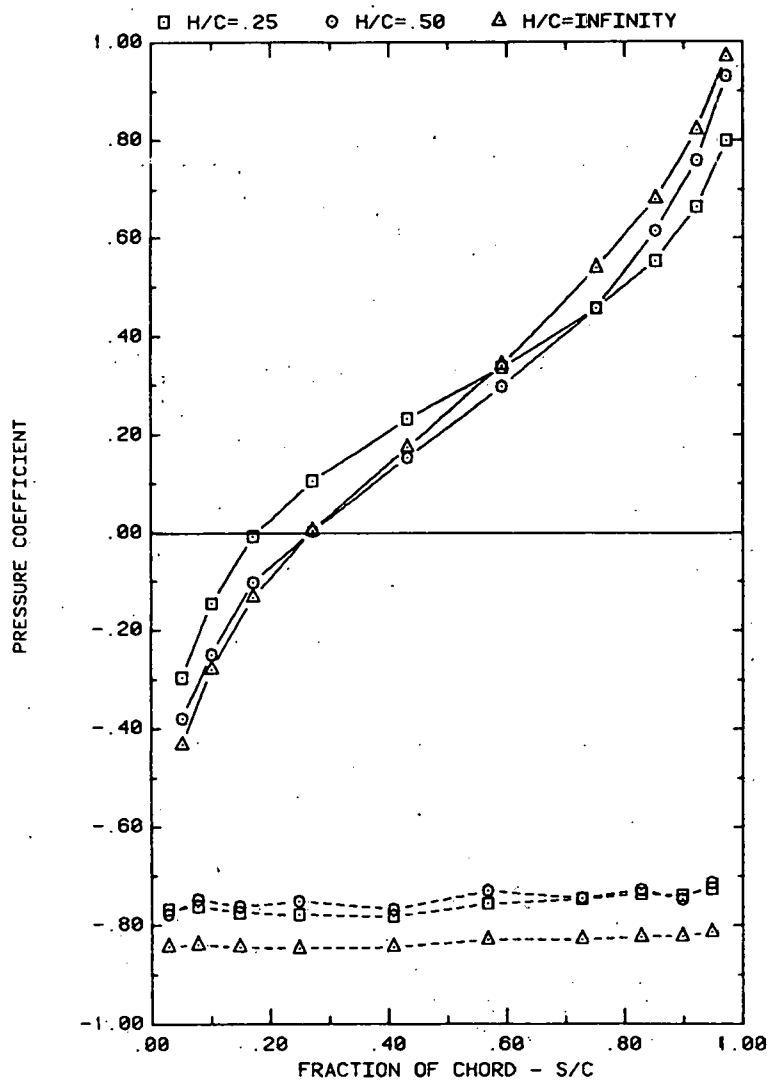

FRONT AND BACK PRESSURES ON A SINGLE ARRAY IN UNIFORM FLOW
EFFECT OF GROUND CLEARANCE FOR ATTACK ANGLE, $\alpha = 20$

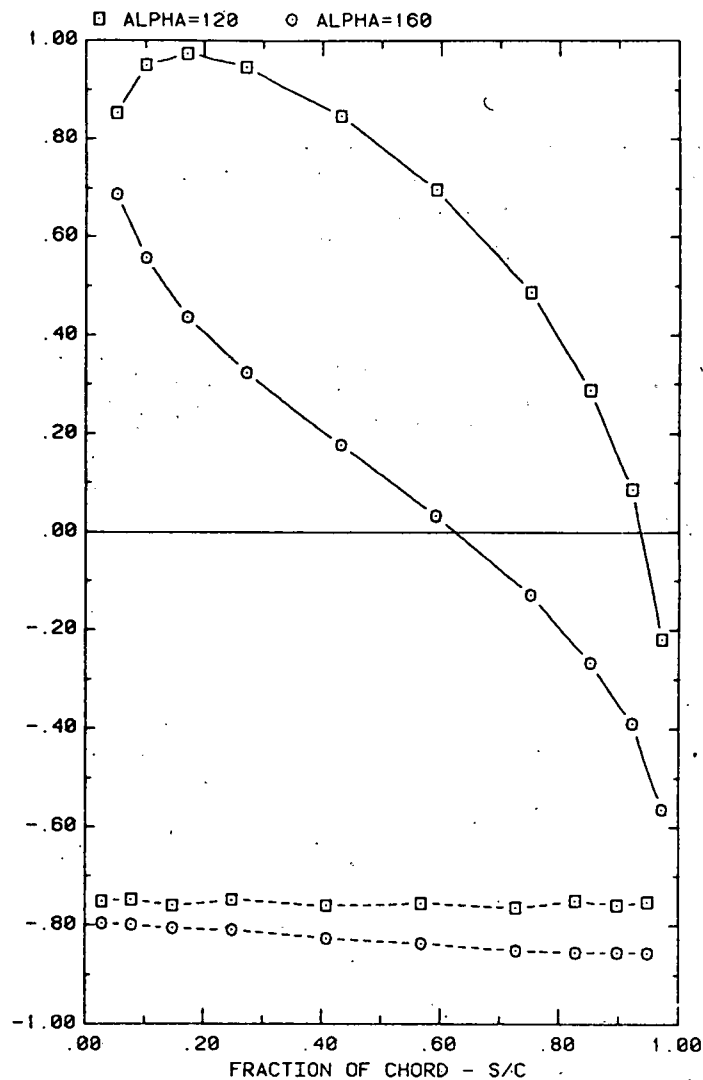

FRONT AND BACK PRESSURES ON A SINGLE ARRAY IN UNIFORM FLOW
EFFECT ON ATTACK ANGLE FOR GROUND CLEARANCE, H/C = 0.50

Plot 1-1. (Continued)

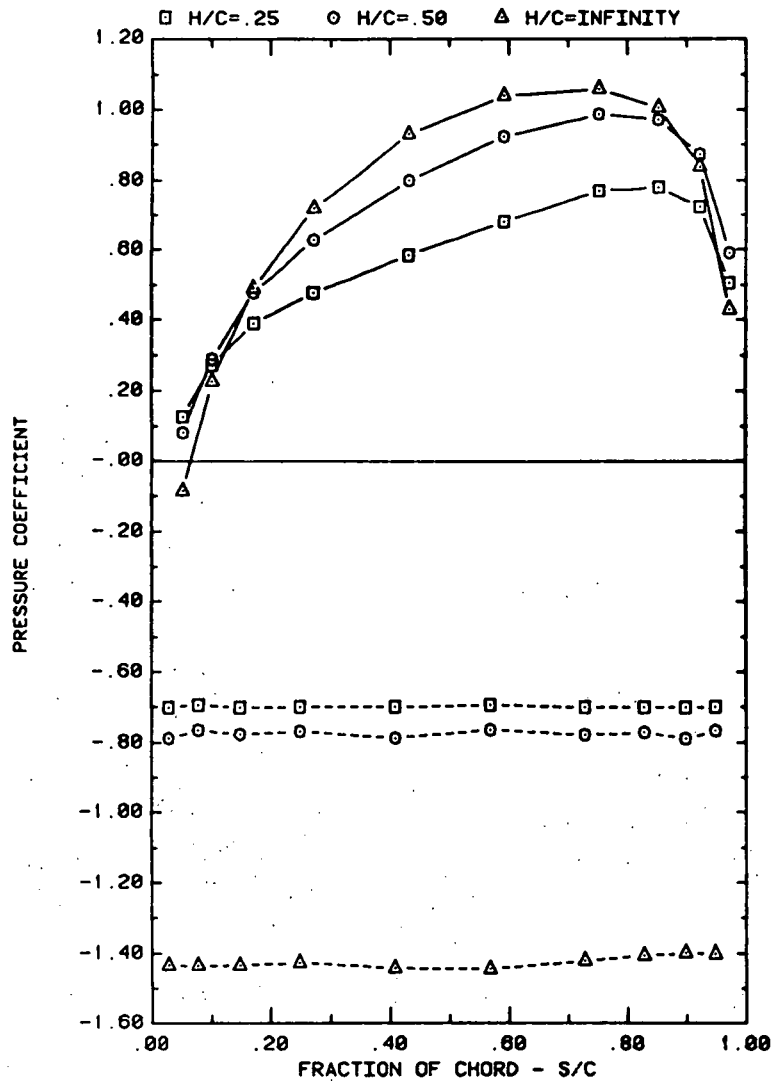

FRONT AND BACK PRESSURES ON A SINGLE ARRAY IN UNIFORM FLOW
EFFECT OF GROUND CLEARANCE FOR ATTACK ANGLE, $\alpha = 60$

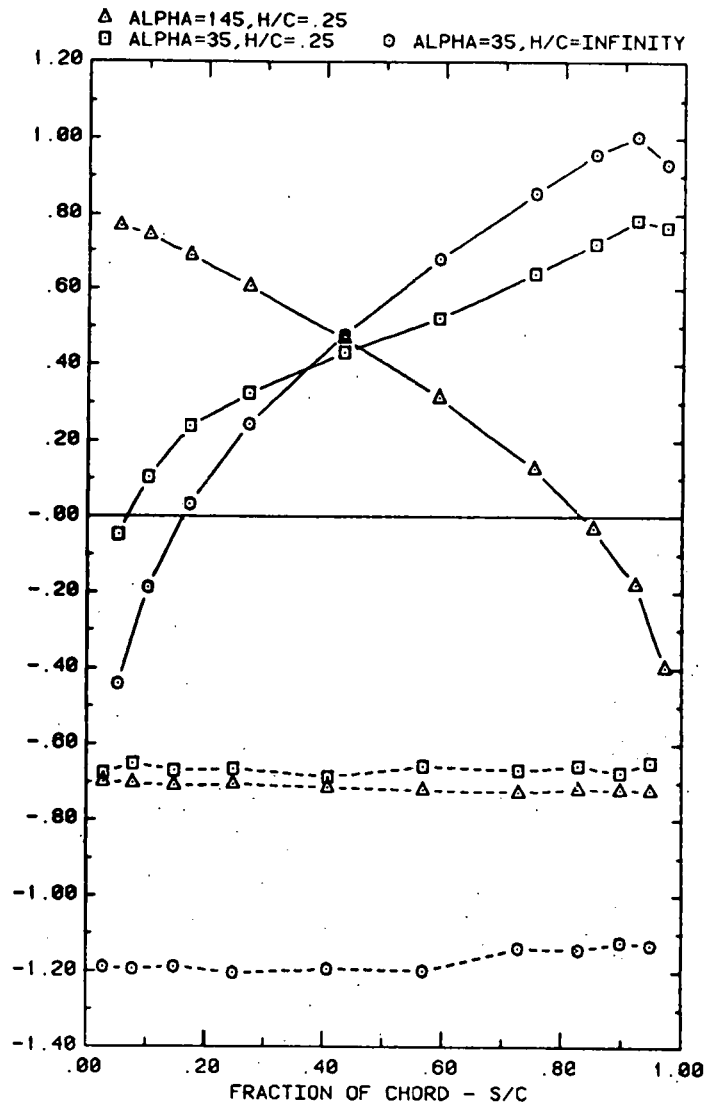

FRONT AND BACK PRESSURES ON A SINGLE ARRAY IN UNIFORM FLOW
EFFECT OF GROUND CLEARANCE FOR ATTACK ANGLES

Plot 1-1. (Continued)

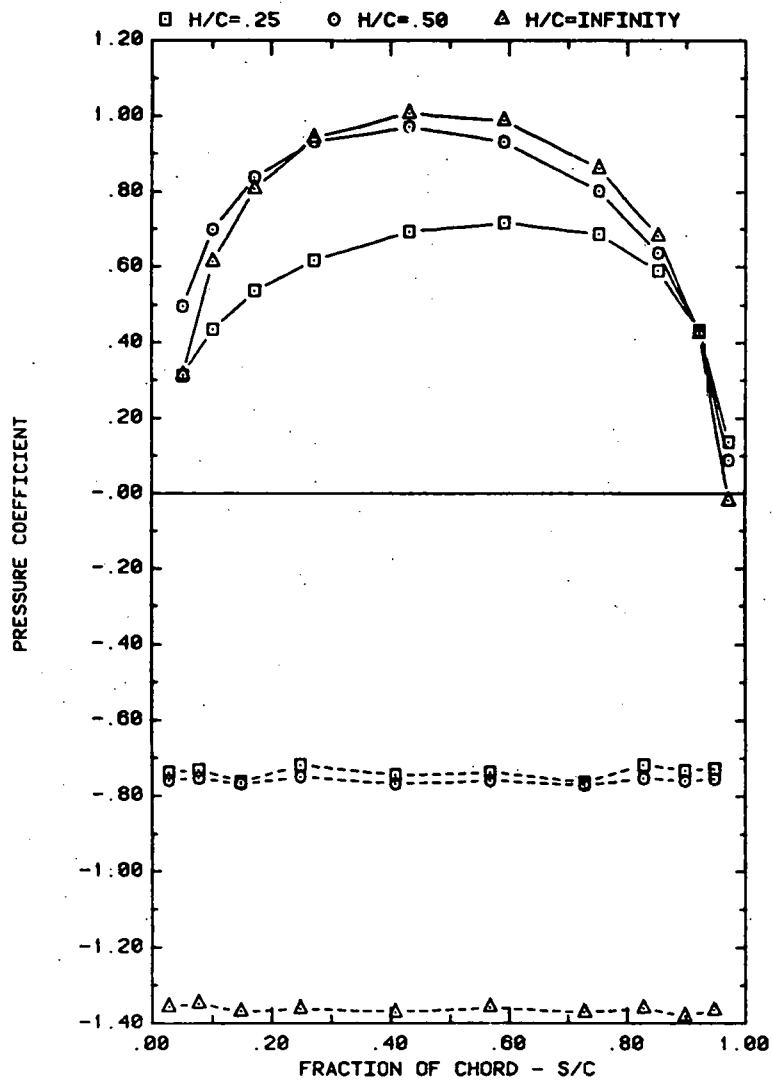

FRONT AND BACK PRESSURES ON A SINGLE ARRAY IN UNIFORM FLOW
EFFECT OF GROUND CLEARANCE FOR ATTACK ANGLE, $\alpha = 90^\circ$

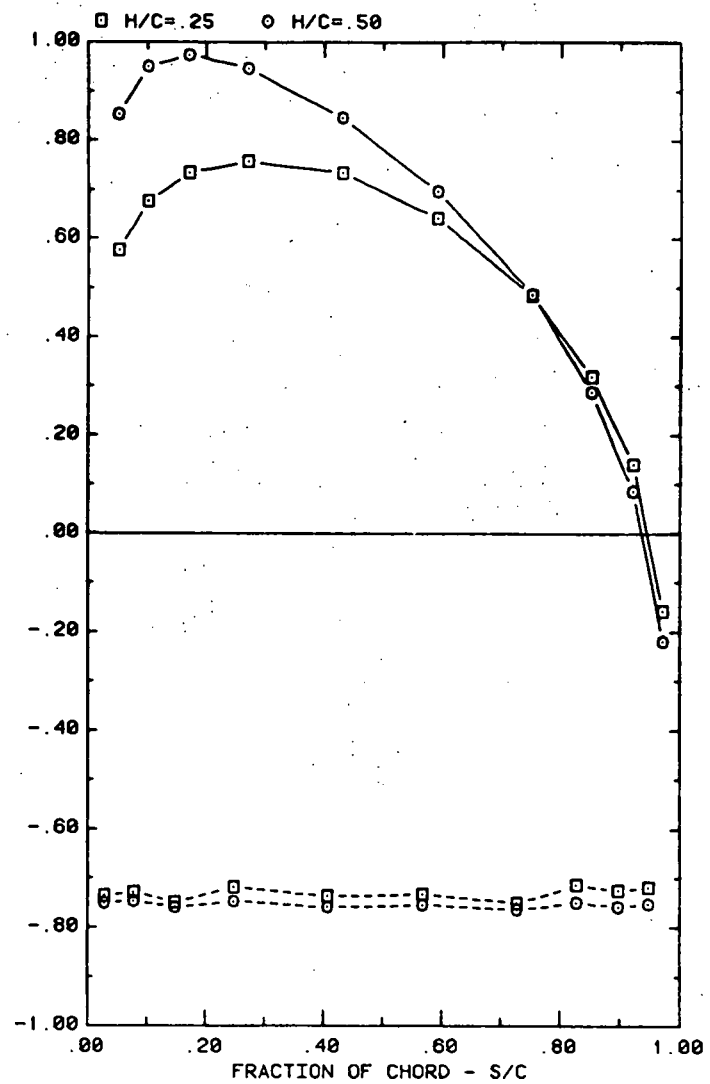

FRONT AND BACK PRESSURES ON A SINGLE ARRAY IN UNIFORM FLOW
EFFECT OF GROUND CLEARANCE FOR ATTACK ANGLE, $\alpha = 120^\circ$

Plot 1-1. (Continued)

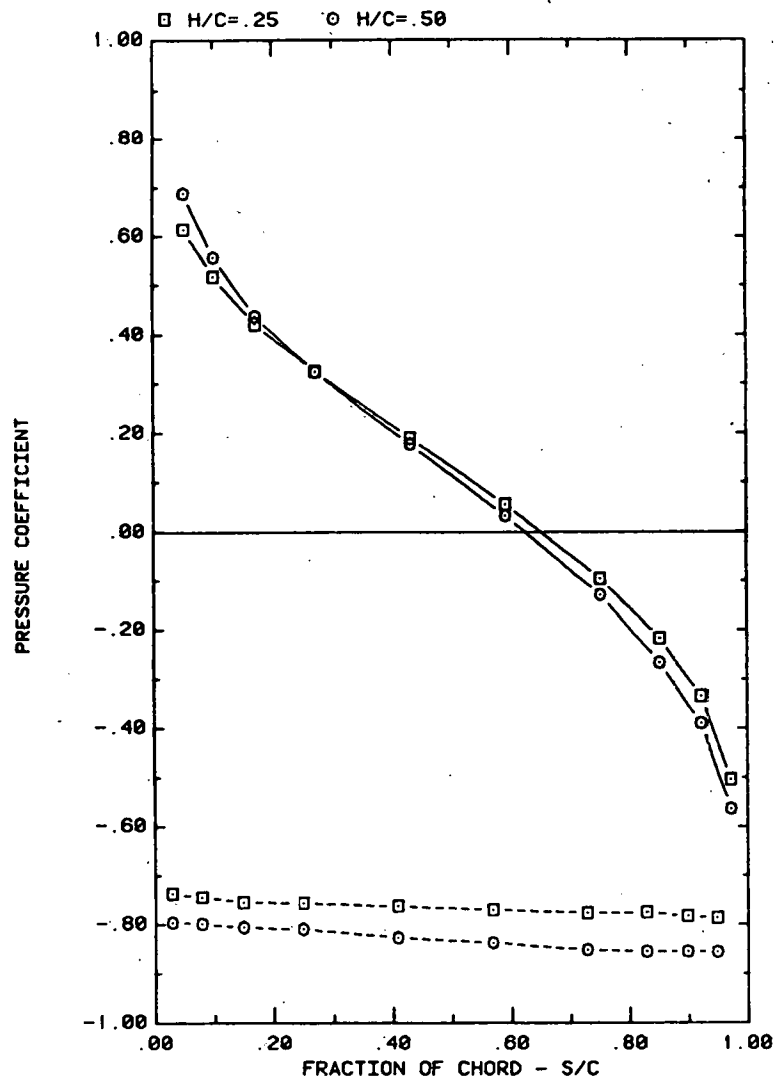

FRONT AND BACK PRESSURES ON A SINGLE ARRAY IN UNIFORM FLOW
EFFECT OF GROUND CLEARANCE FOR ATTACK ANGLE, ALPHA = 160

Plot 1-1. (Concluded)

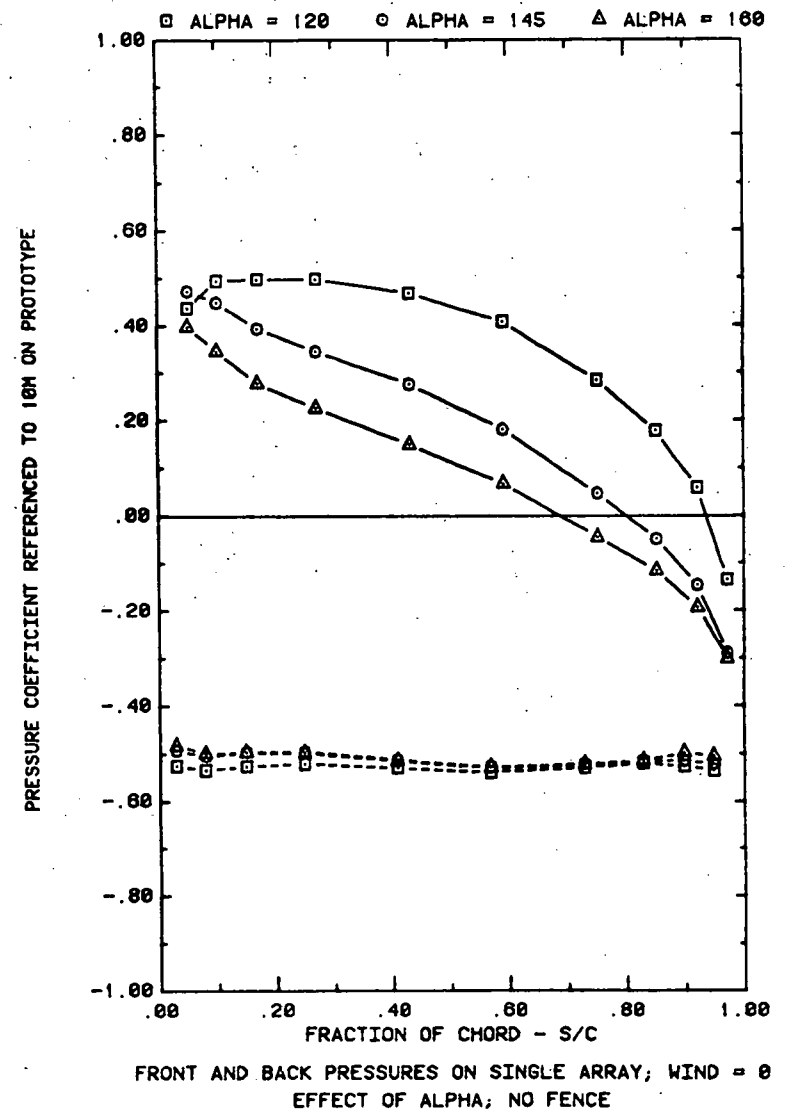
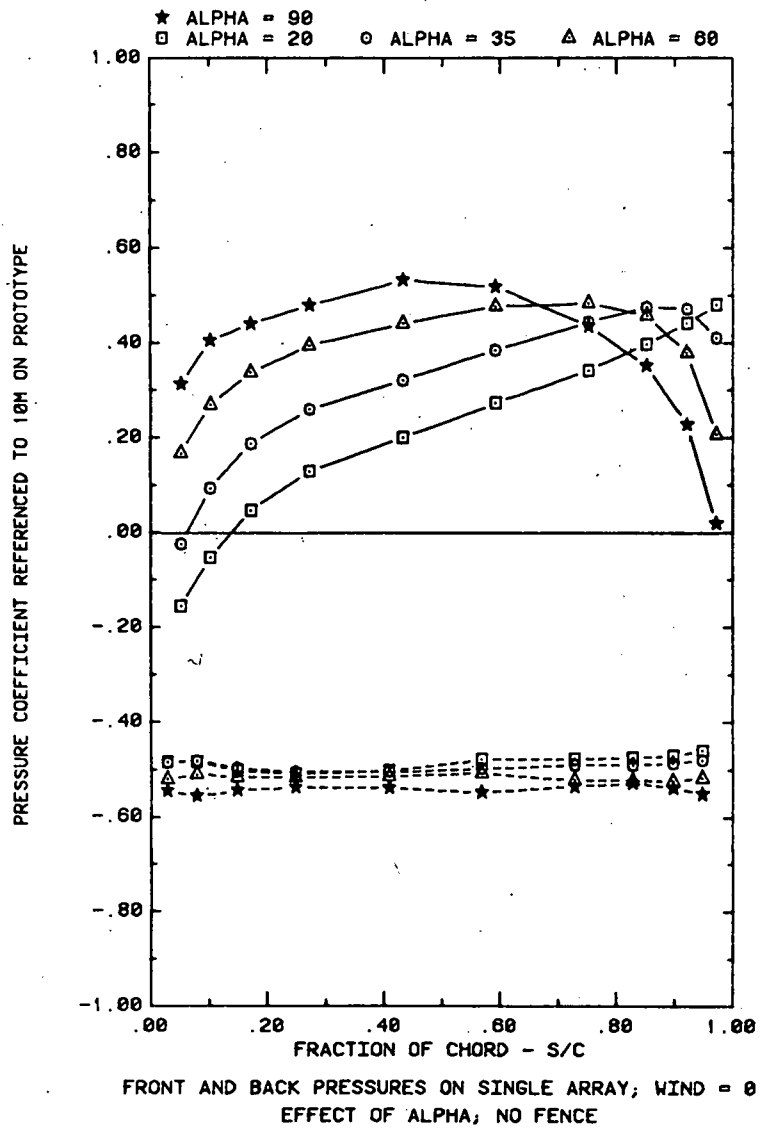

Plot 1-2. Single Array, Nonuniform Flow Study Effects of Angle of Attack and Fence Height

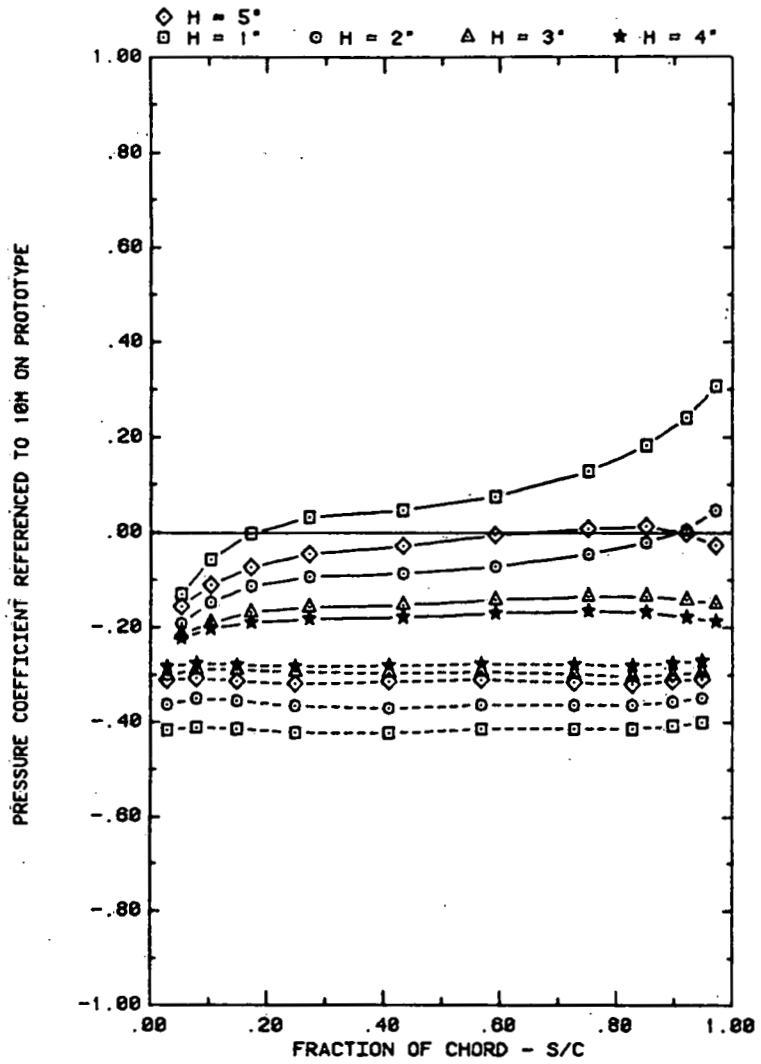

FRONT AND BACK PRESSURES ON SINGLE ARRAY, WIND = 0
 EFFECT OF FENCE HEIGHT, ALPHA = 35, D = 10, P = 30%

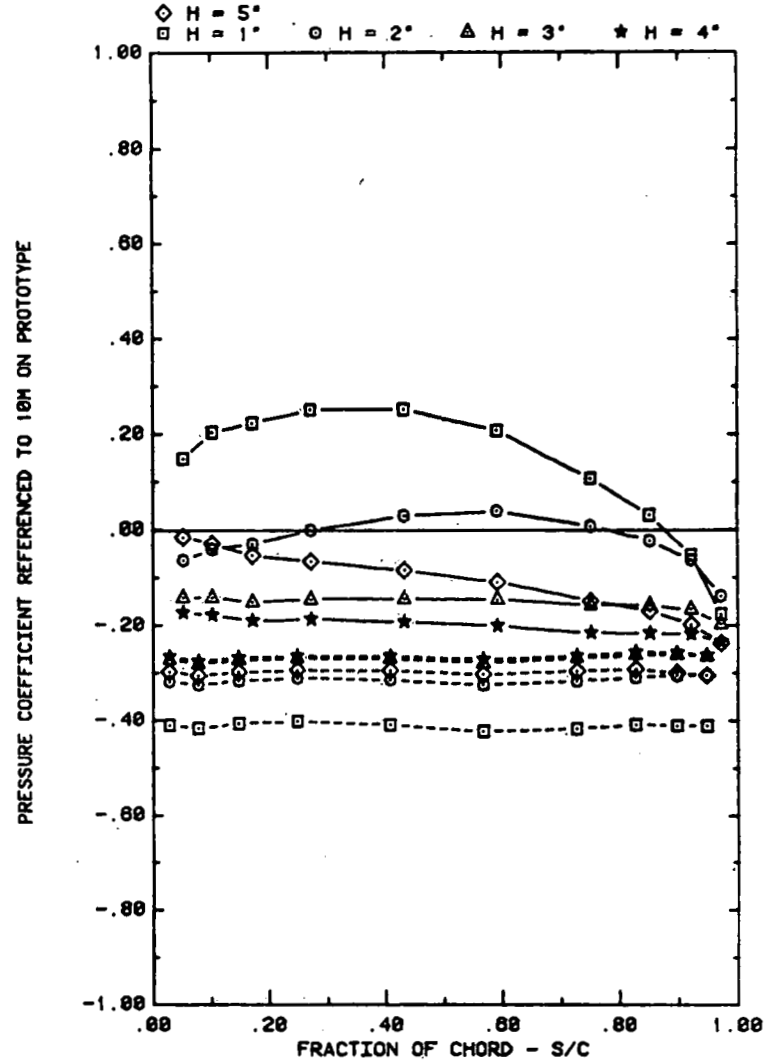

FRONT AND BACK PRESSURES ON SINGLE ARRAY, WIND = 0
 EFFECT OF FENCE HEIGHT, ALPHA = 145, D = 10, P = 30%

Plot 1-2. (Concluded)

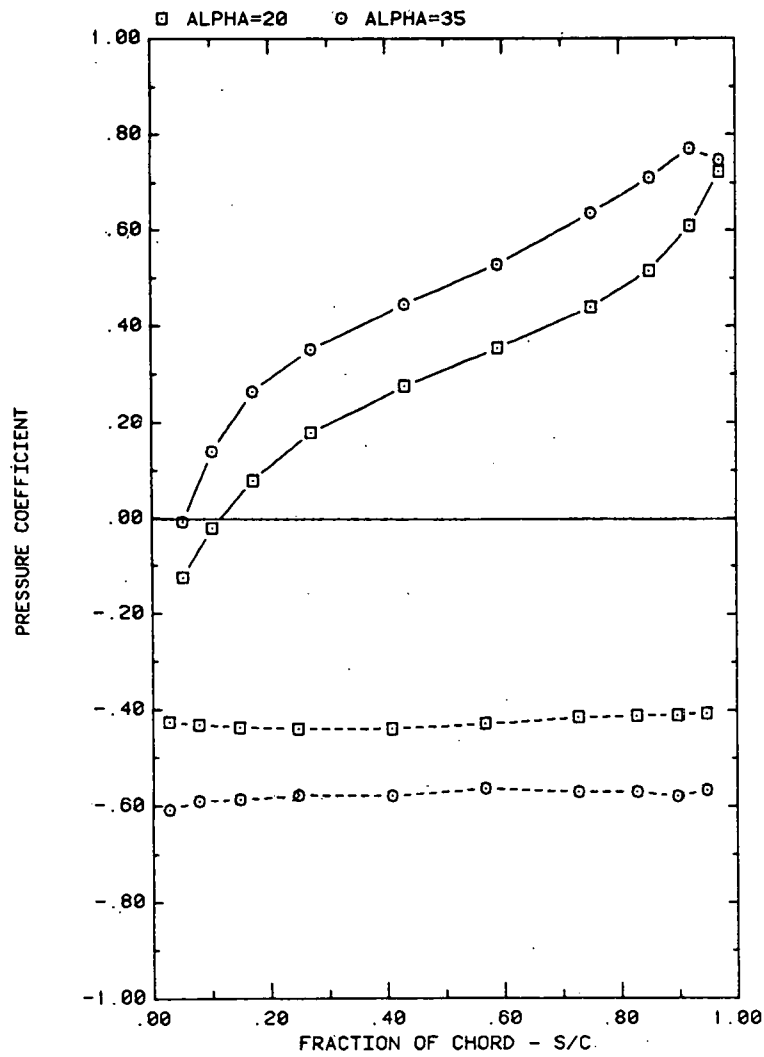

FRONT AND BACK PRESSURES ON ARRAY #1 IN UNIFORM FLOW
EFFECT OF ATTACK ANGLE FOR SPACING = 1.5C

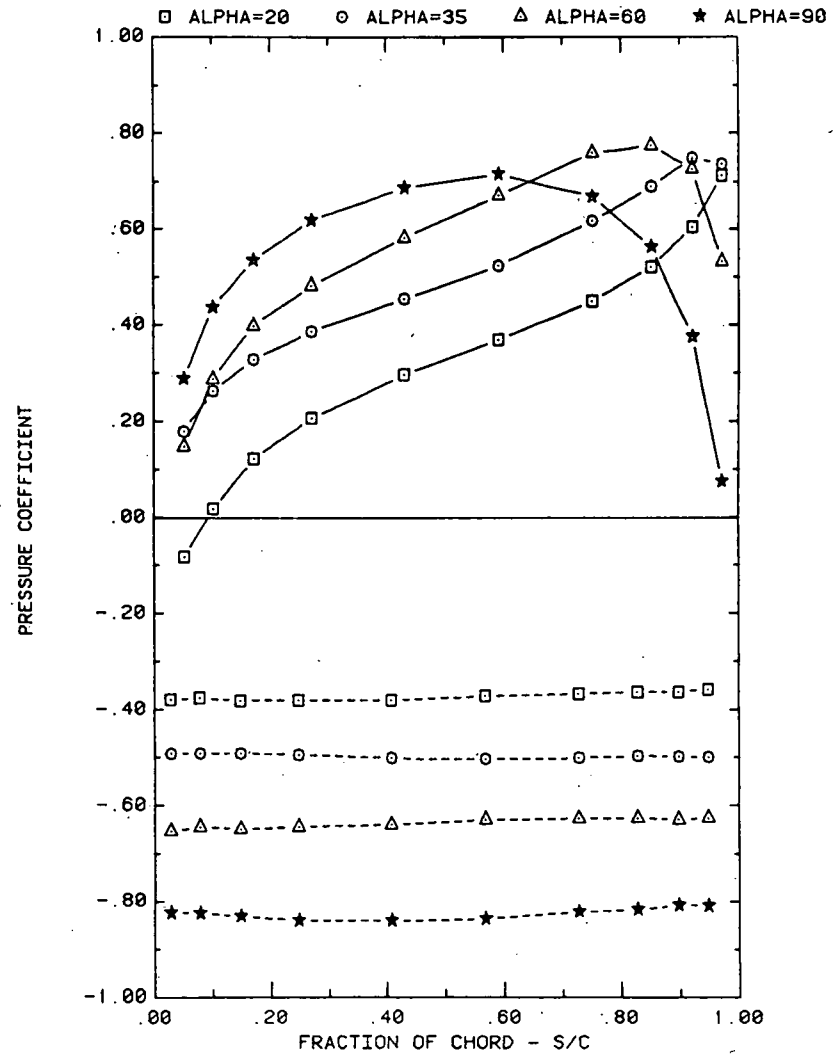

FRONT AND BACK PRESSURES ON ARRAY #1 IN UNIFORM FLOW
EFFECT OF ATTACK ANGLE FOR SPACING = 2C

Plot 2-1-1. Multiple Arrays without Fence, Uniform Flow Study
Effect of Angle of Attack

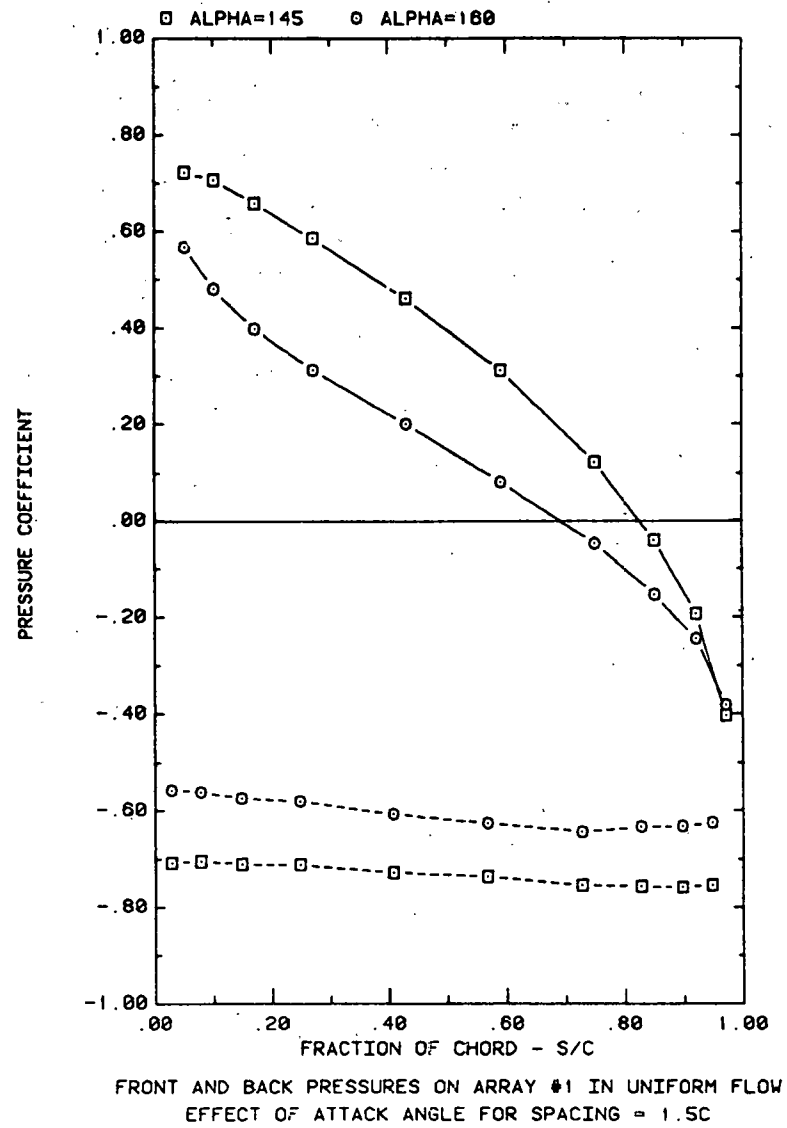
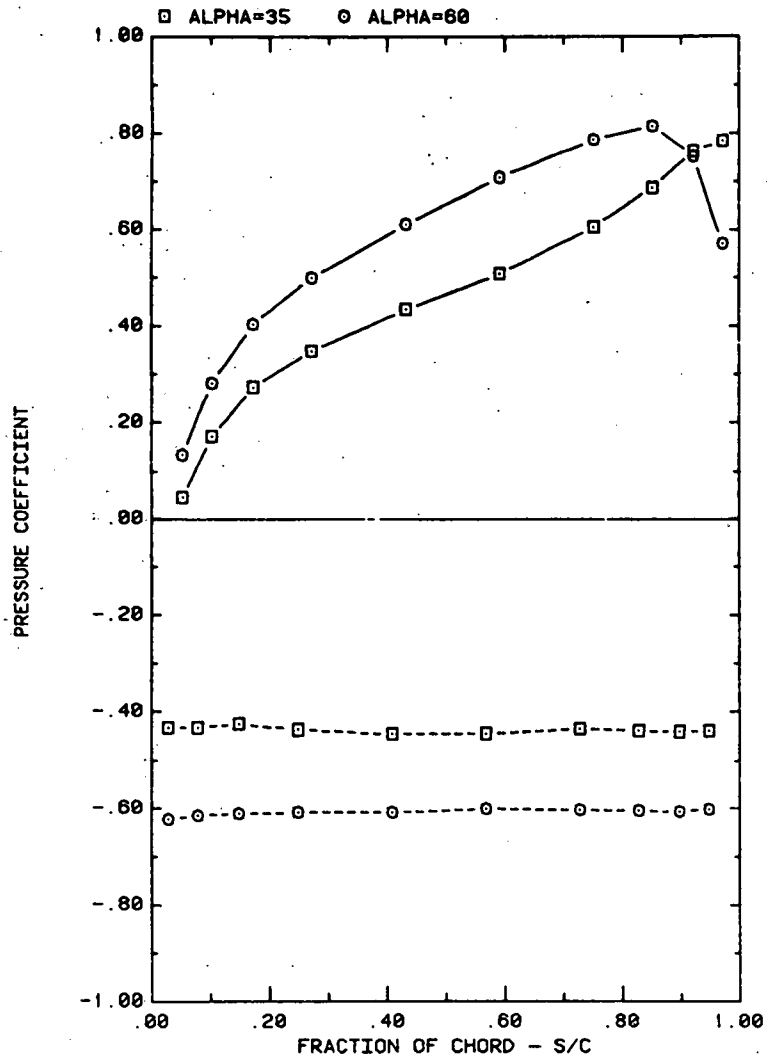

Plot 2-1-1. (Continued)

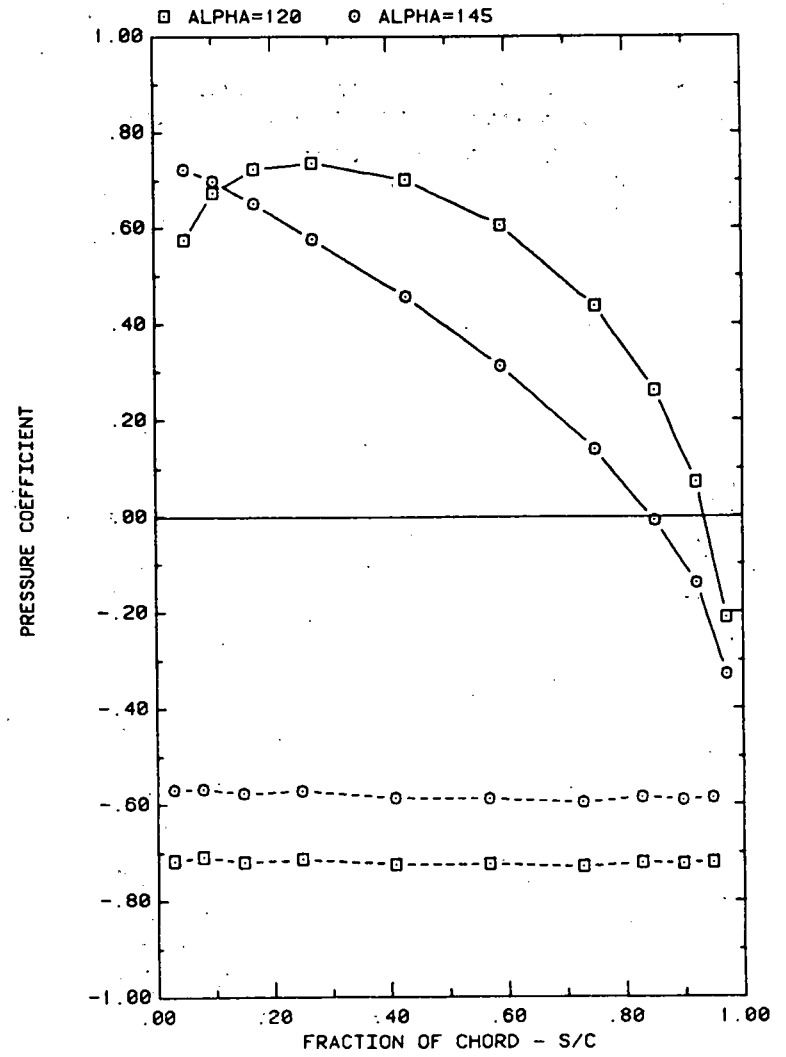
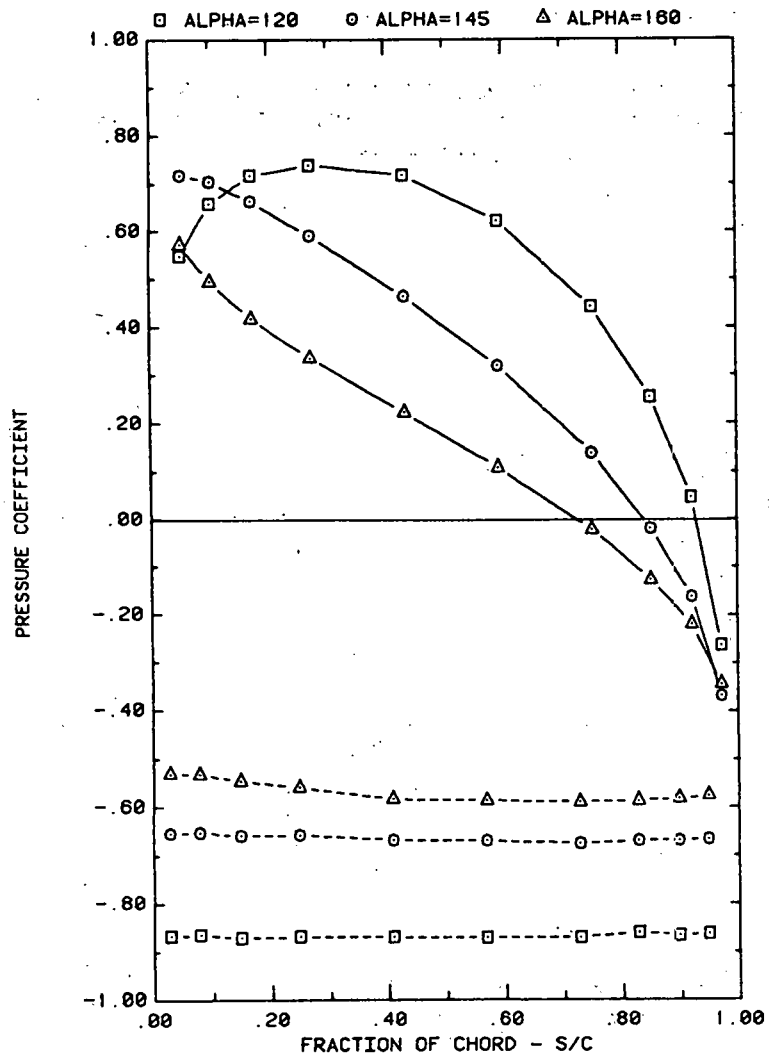

Plot 2-1-1. (Continued)

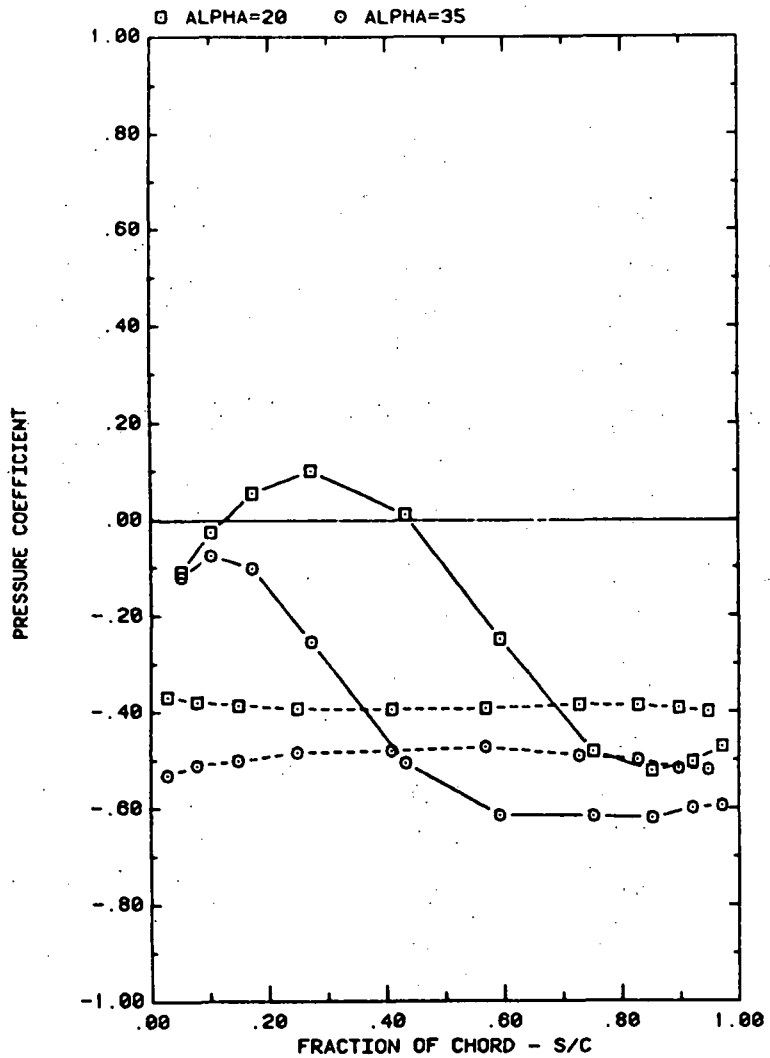

FRONT AND BACK PRESSURES ON ARRAY #2 IN UNIFORM FLOW
EFFECT OF ATTACK ANGLE FOR SPACING = 1.5C

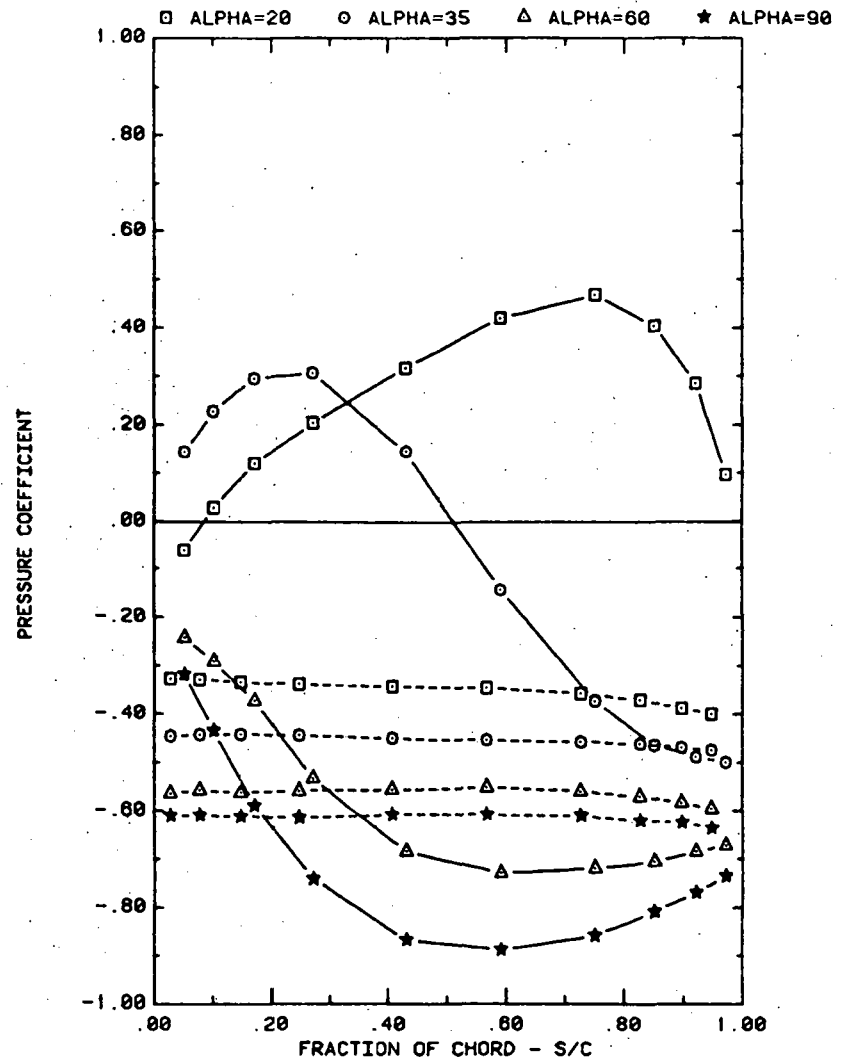

FRONT AND BACK PRESSURES ON ARRAY #2 IN UNIFORM FLOW
EFFECT OF ATTACK ANGLE FOR SPACING = 2C

Plot 2-1-1. (Continued)

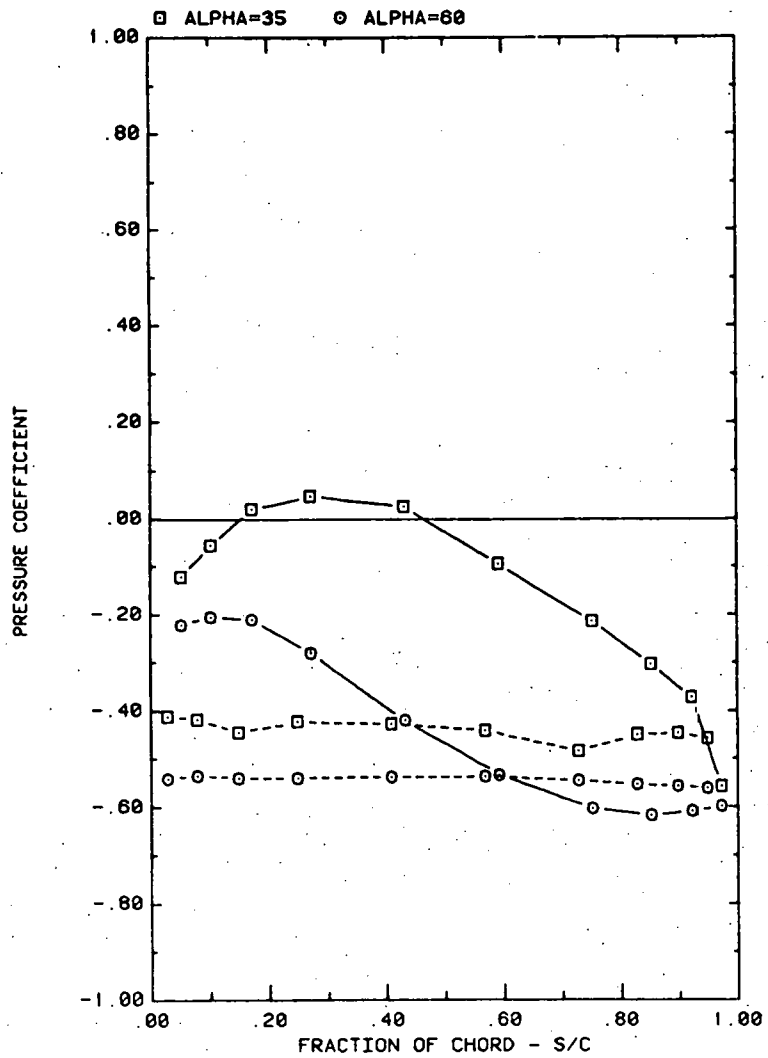

FRONT AND BACK PRESSURES ON ARRAY #2 IN UNIFORM FLOW
EFFECT OF ATTACK ANGLE FOR SPACING = 3C

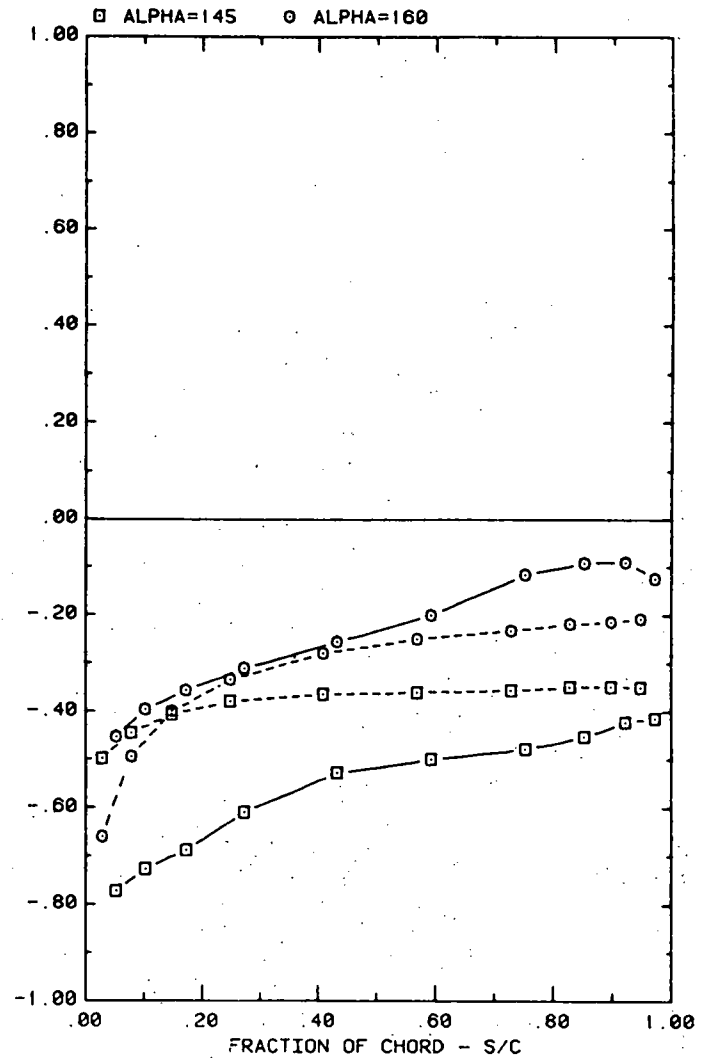

FRONT AND BACK PRESSURES ON ARRAY #2 IN UNIFORM FLOW
EFFECT OF ATTACK ANGLE FOR SPACING = 1.5C

Plot 2-1-1. (Continued)

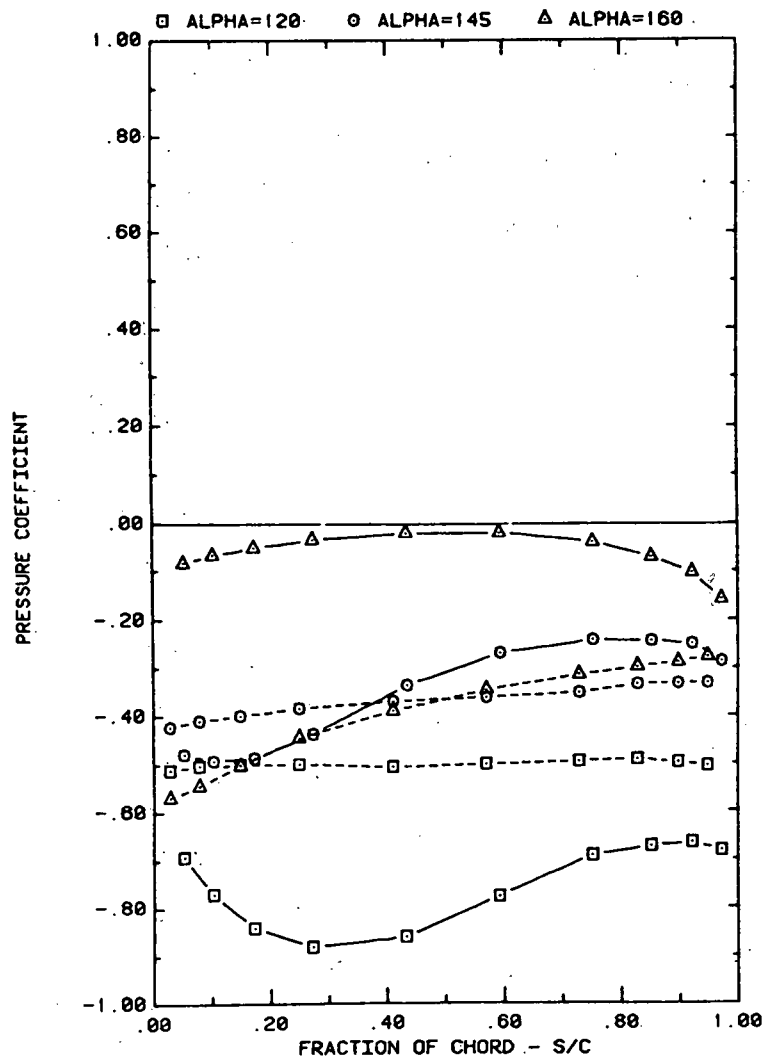

FRONT AND BACK PRESSURES ON ARRAY #2 IN UNIFORM FLOW.
EFFECT OF ATTACK ANGLE FOR SPACING = 2C

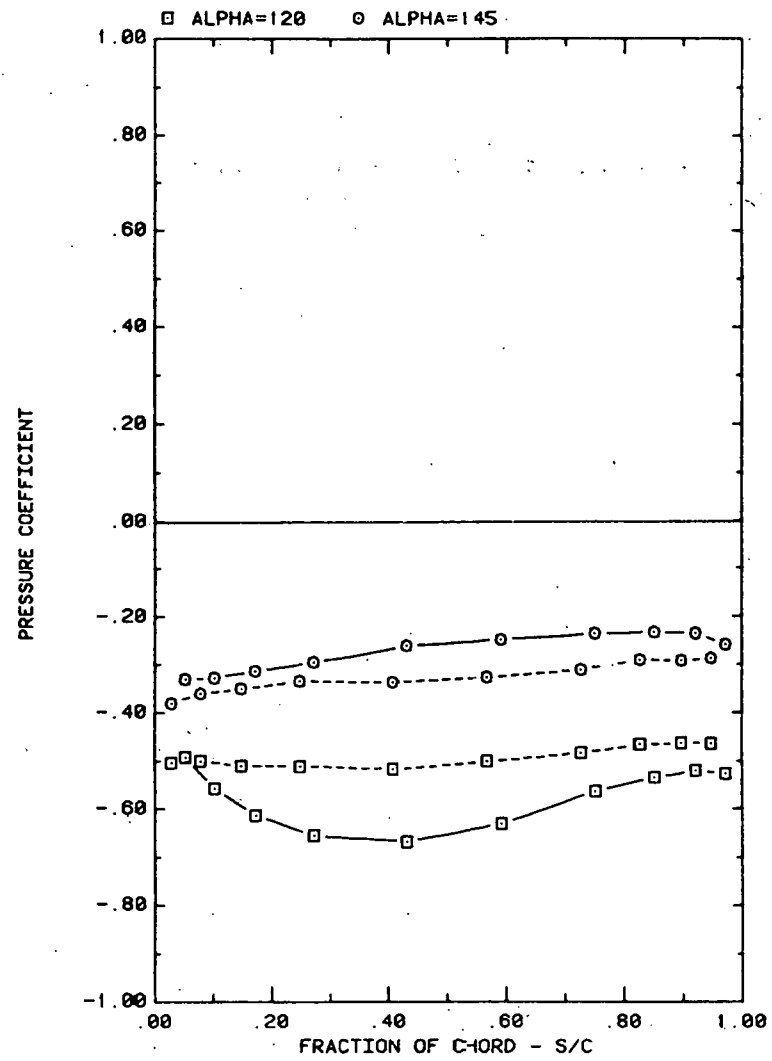

FRONT AND BACK PRESSURES ON ARRAY #2 IN UNIFORM FLOW.
EFFECT OF ATTACK ANGLE FOR SPACING = 3C

Plot 2-1-1. (Continued)

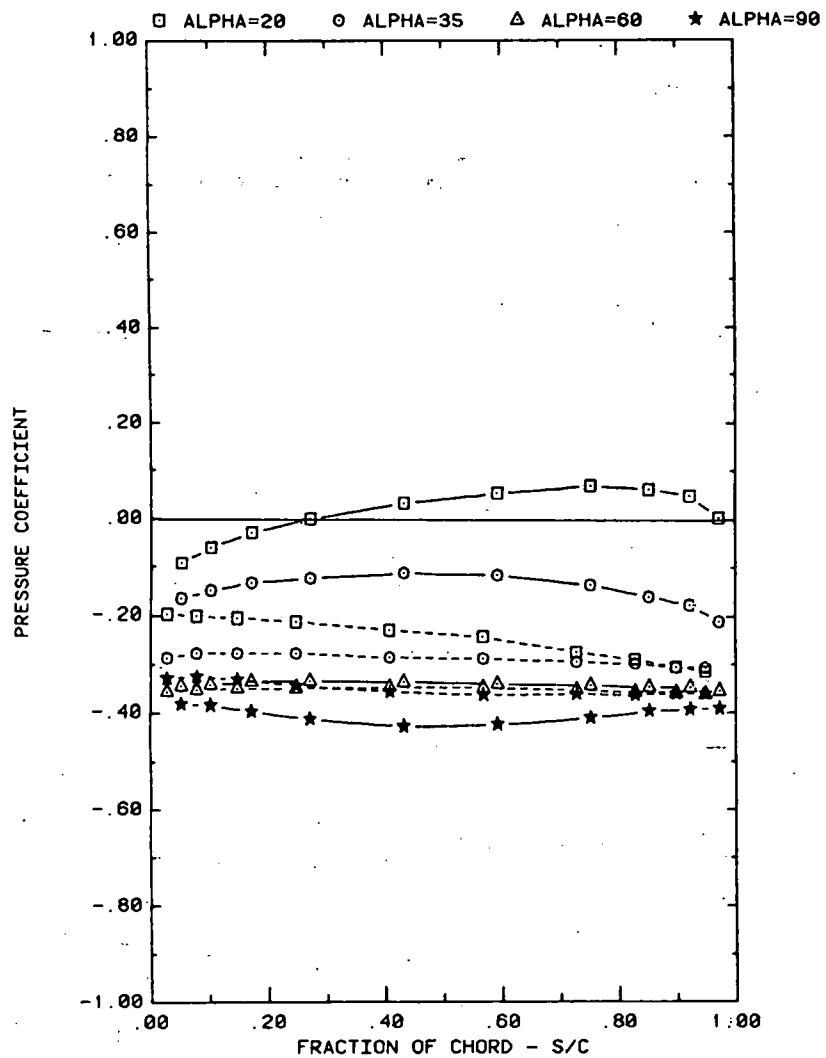

FRONT AND BACK PRESSURES ON ARRAY #5 IN UNIFORM FLOW
EFFECT OF ATTACK ANGLE FOR SPACING = 2C

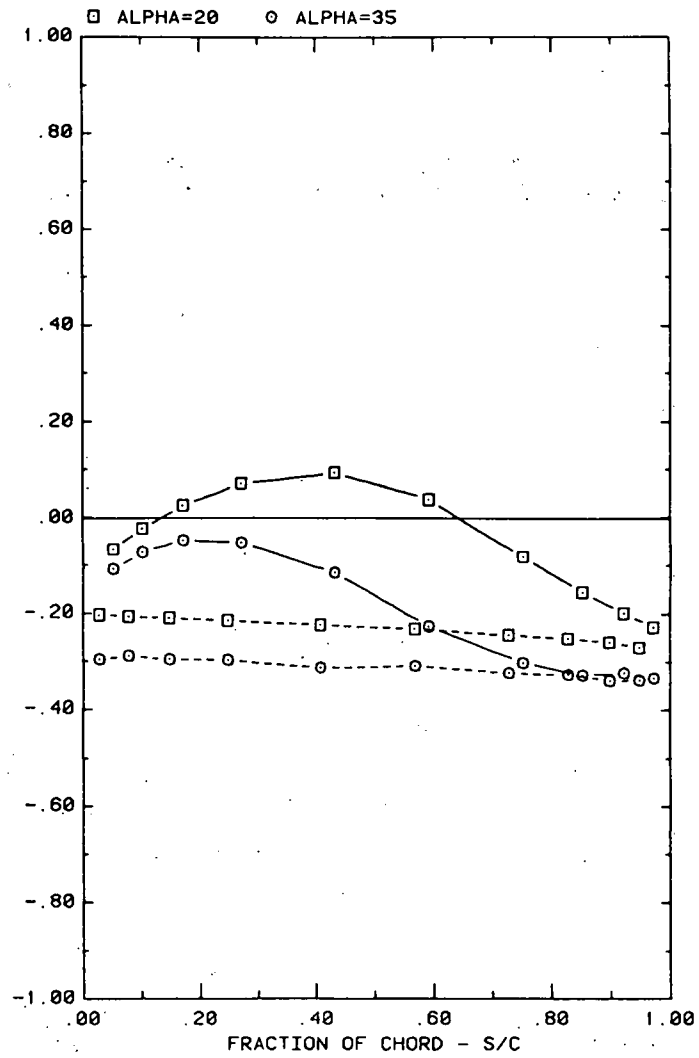

FRONT AND BACK PRESSURES ON ARRAY #5 IN UNIFORM FLOW
EFFECT OF ATTACK ANGLE FOR SPACING = 1.5C

Plot 2-1-1. (Continued)

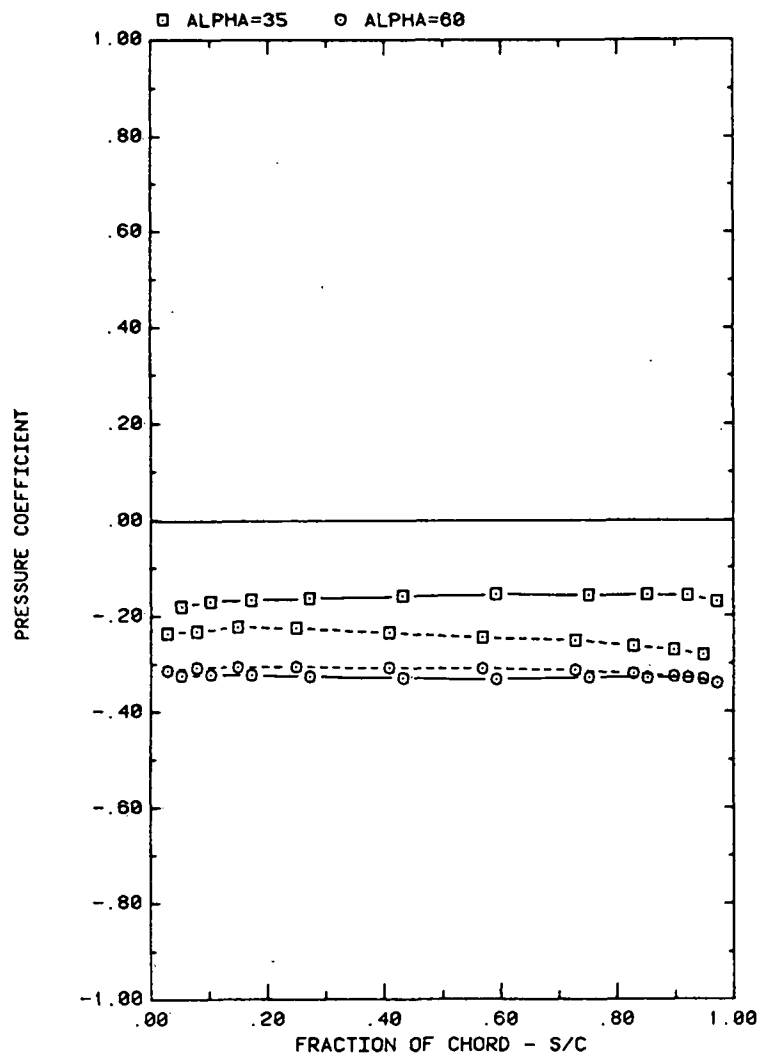

FRONT AND BACK PRESSURES ON ARRAY #4 IN UNIFORM FLOW
EFFECT OF ATTACK ANGLE FOR SPACING = 3C

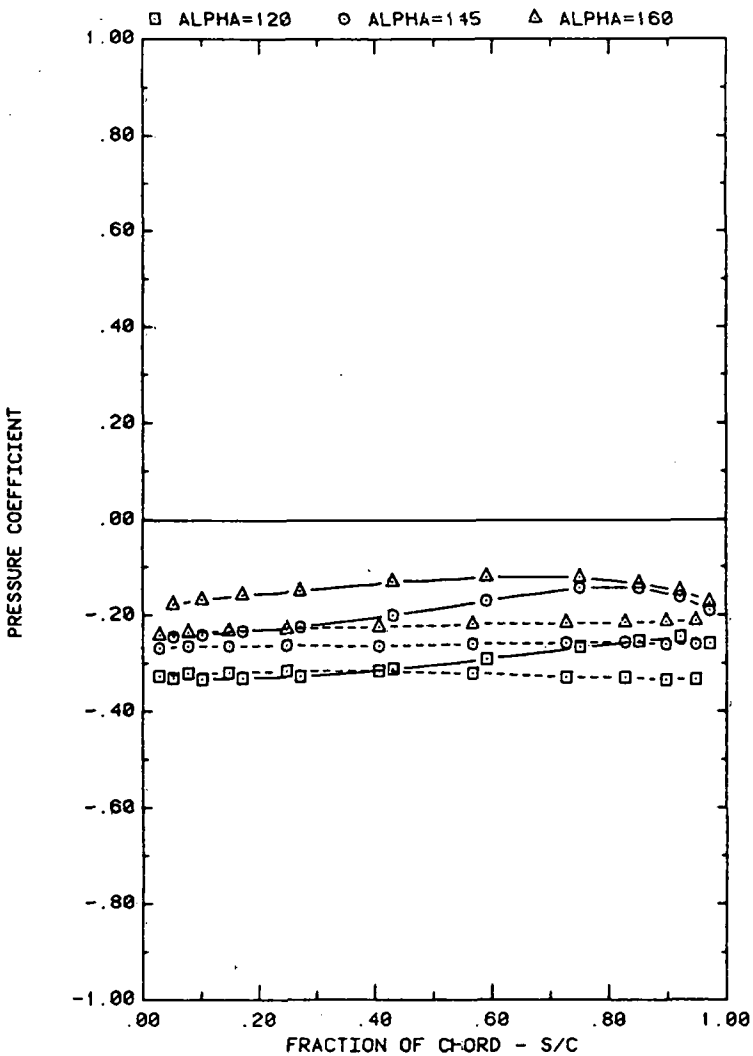

FRONT AND BACK PRESSURES ON ARRAY #5 IN UNIFORM FLOW
EFFECT OF ATTACK ANGLE FOR SPACING = 2C

Plot 2-1-1. (Continued)

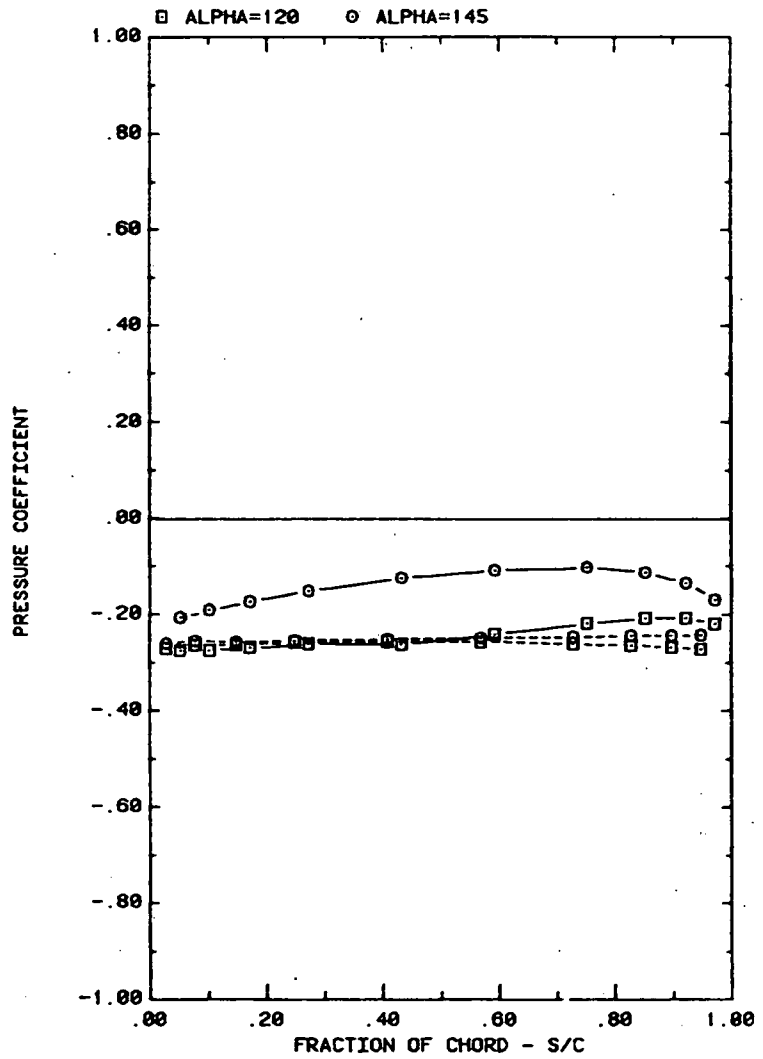

FRONT AND BACK PRESSURES ON ARRAY #4 IN UNIFORM FLOW
EFFECT OF ATTACK ANGLE FOR SPACING = 3C

Plot 2-1-1. (Concluded)

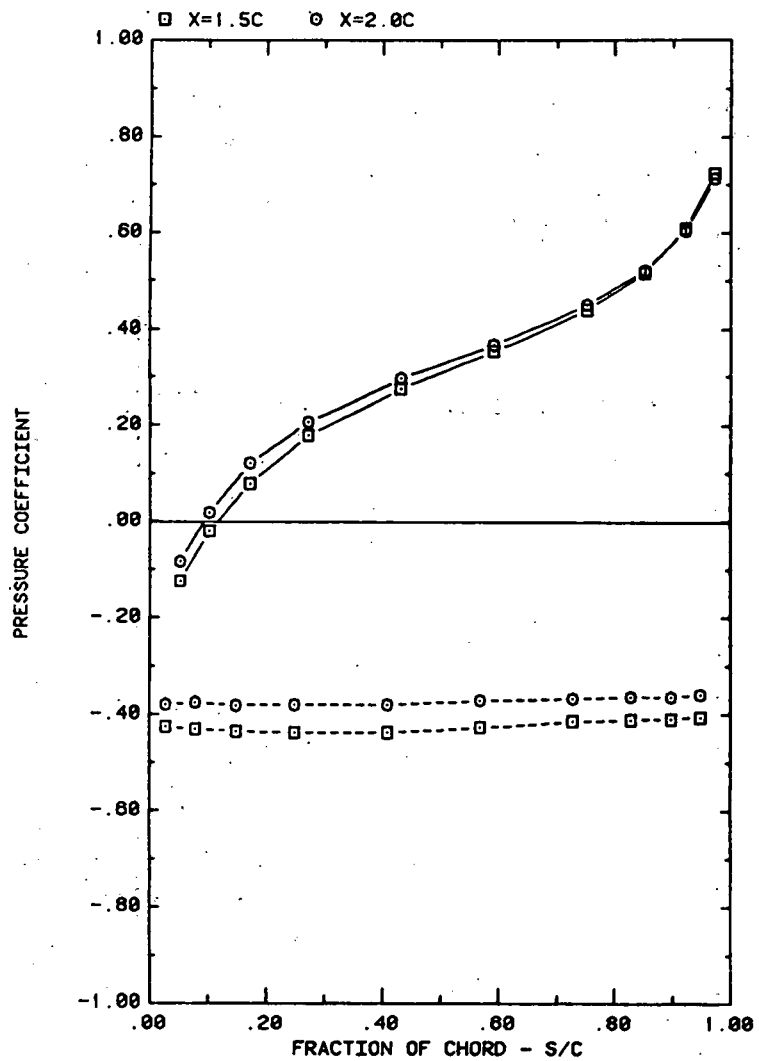

FRONT AND BACK PRESSURES ON ARRAY #1 IN UNIFORM FLOW
EFFECT OF SEPARATION (X) ON ATTACK ANGLE 20, H/C = 0.25

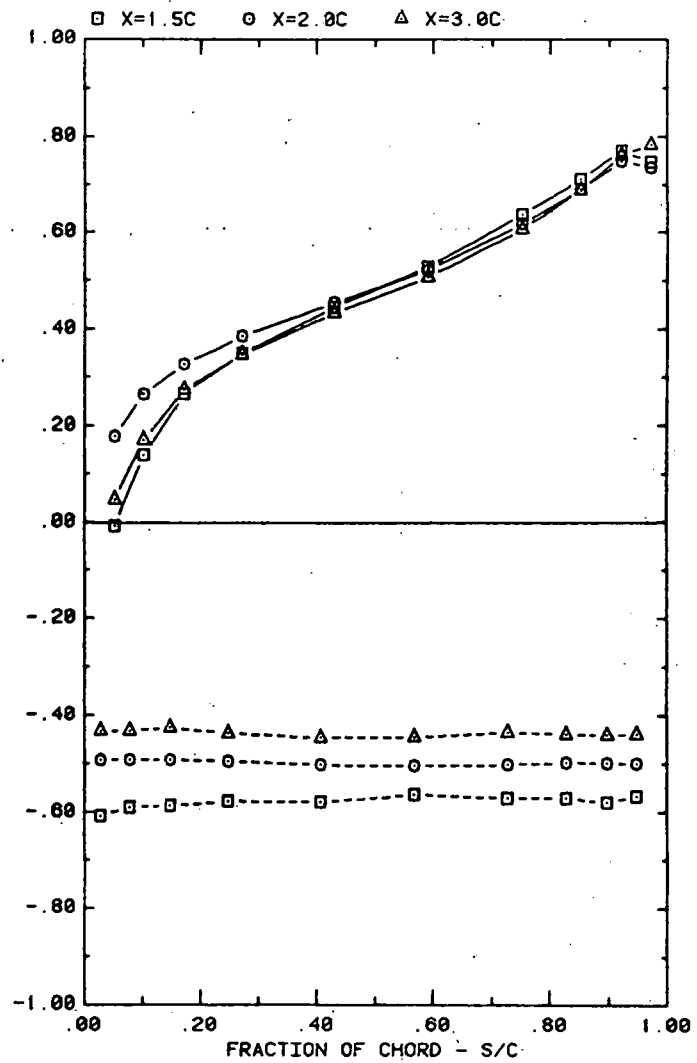

FRONT AND BACK PRESSURES ON ARRAY #1 IN UNIFORM FLOW
EFFECT OF SEPARATION (X) ON ATTACK ANGLE 35, H/C = 0.25

Plot 2-1-2. Multiple Arrays without Fence, Uniform Flow Study
Effect of Separation Distance

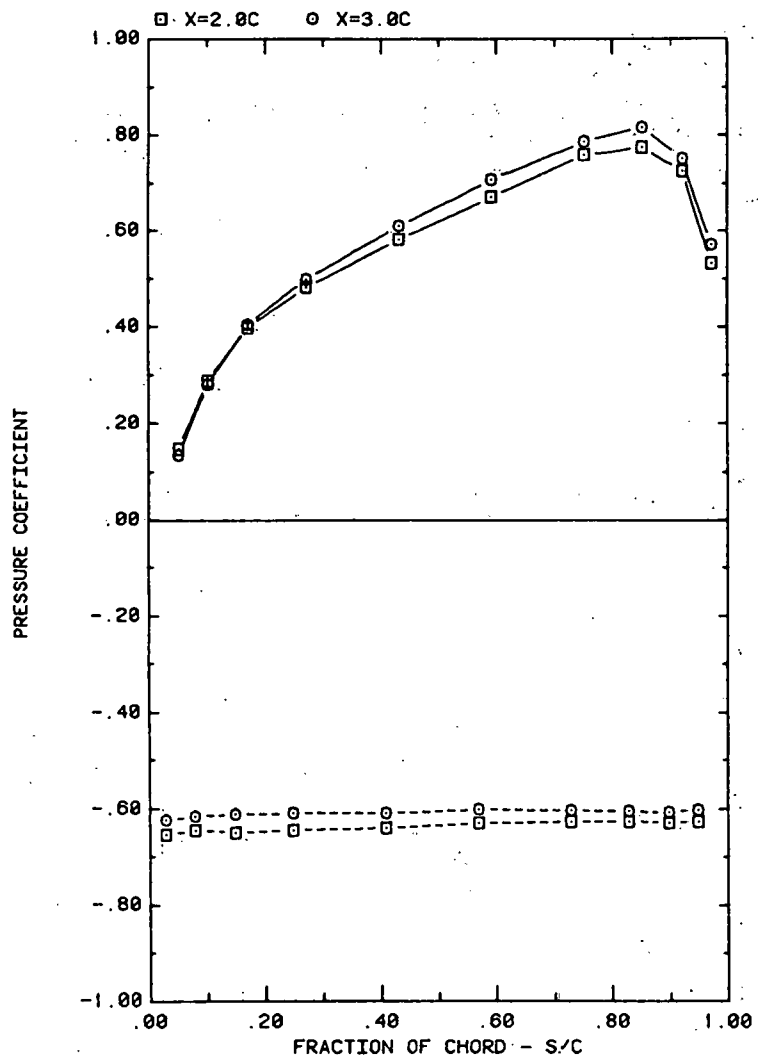

FRONT AND BACK PRESSURES ON ARRAY #1 IN UNIFORM FLOW
EFFECT OF SEPARATION (X) ON ATTACK ANGLE 60, H/C = 0.25

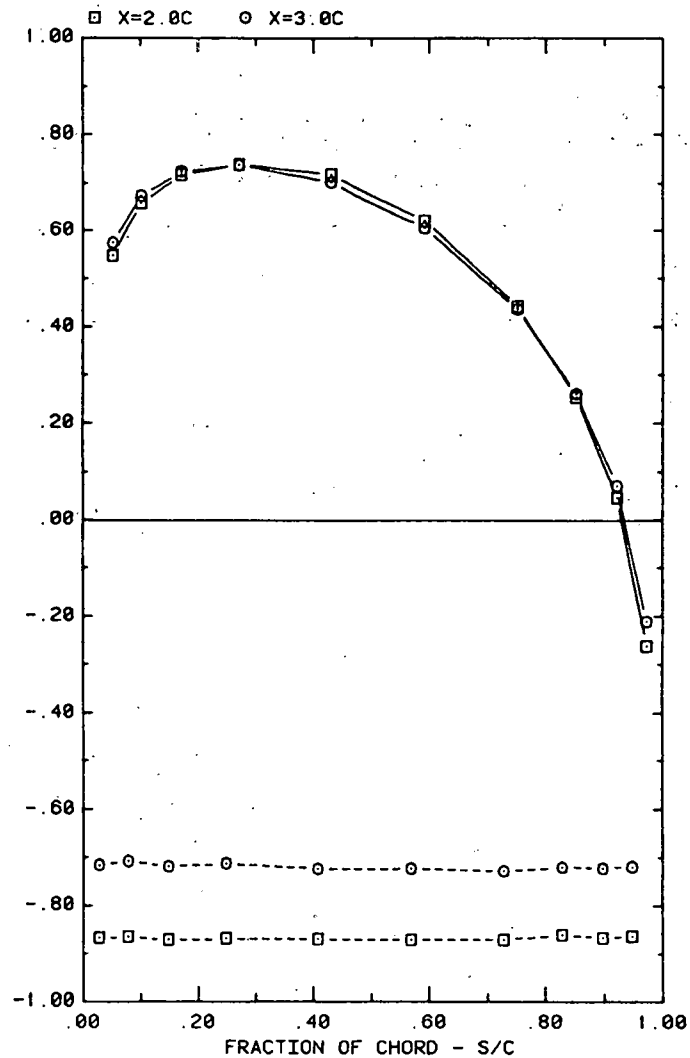

FRONT AND BACK PRESSURES ON ARRAY #1 IN UNIFORM FLOW
EFFECT OF SEPARATION (X) ON ATTACK ANGLE 120, H/C = 0.25

Plot 2-1-2. (Continued)

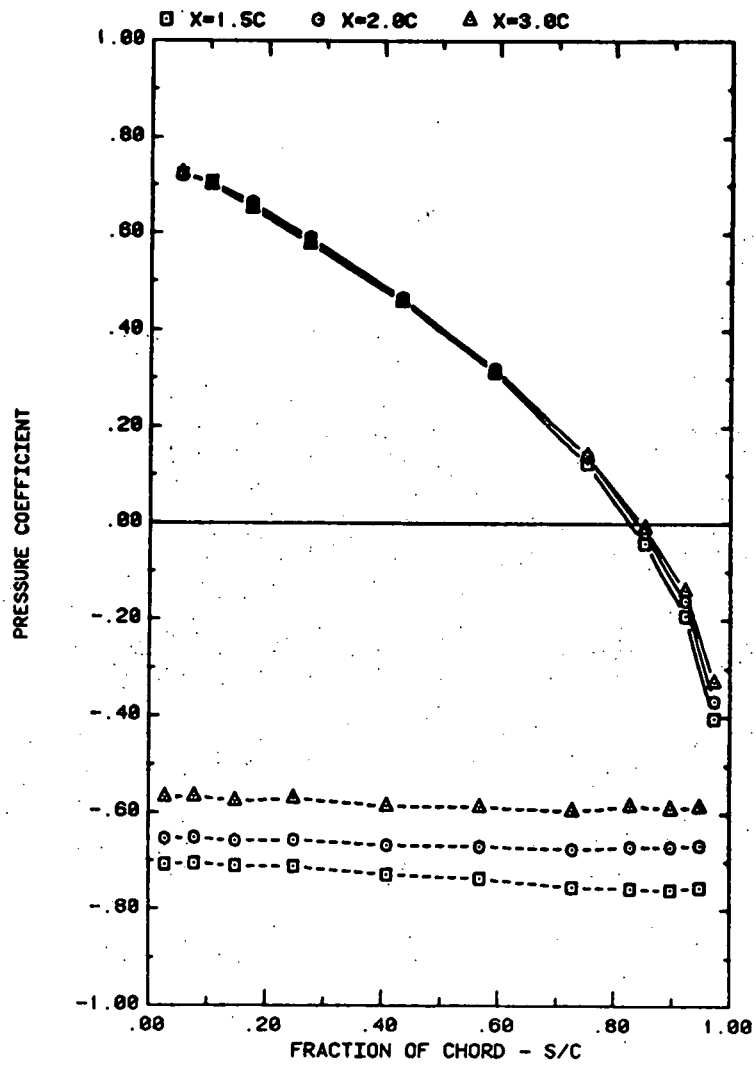

FRONT AND BACK PRESSURES ON ARRAY #1 IN UNIFORM FLOW
 EFFECT OF SEPARATION (X) ON ATTACK ANGLE 145, H/C = 0.25

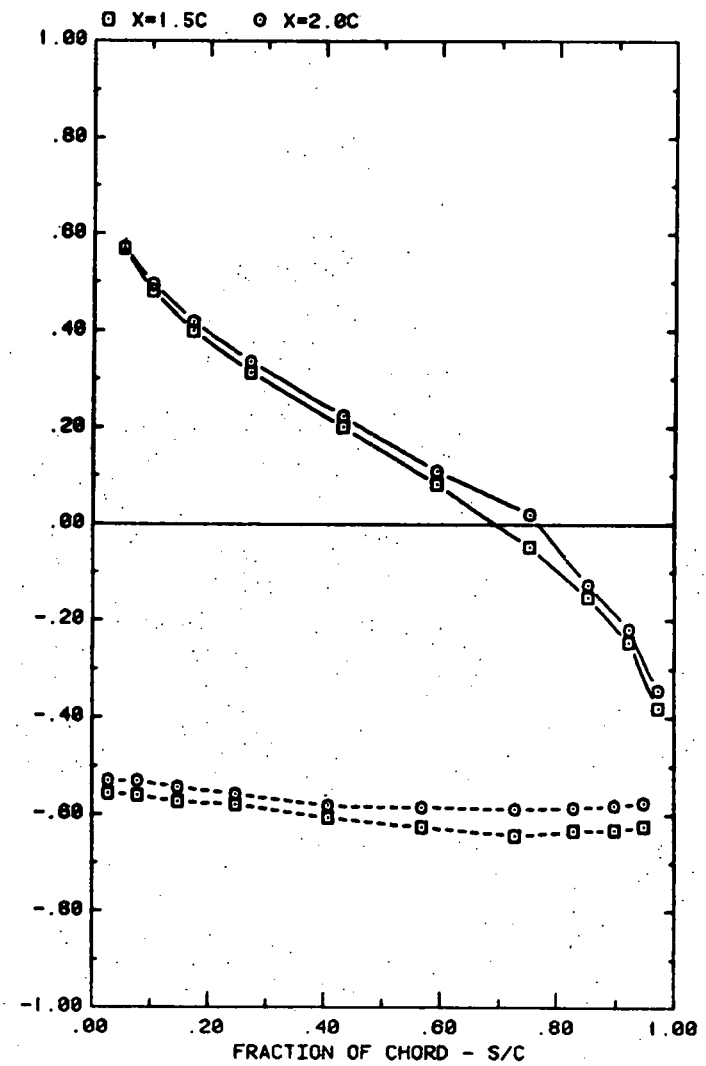

FRONT AND BACK PRESSURES ON ARRAY #1 IN UNIFORM FLOW
 EFFECT OF SEPARATION (X) ON ATTACK ANGLE 160, H/C = 0.25

Plot 2-1-2. (Continued)

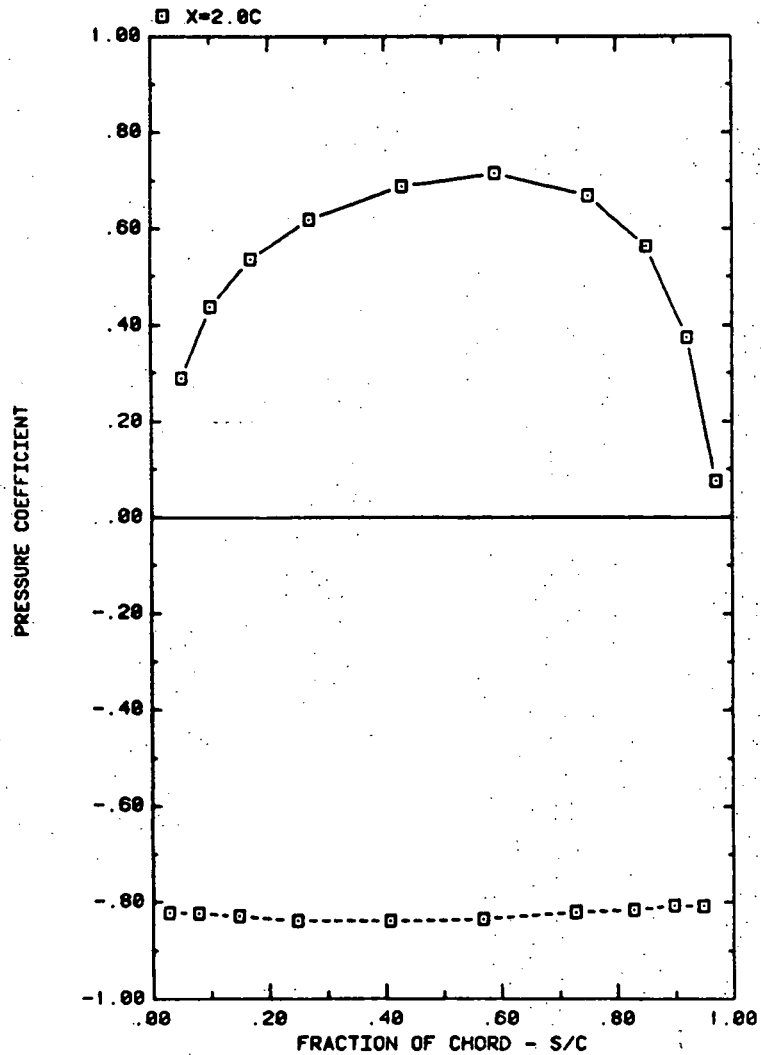

FRONT AND BACK PRESSURES ON ARRAY #1 IN UNIFORM FLOW
EFFECT OF SEPARATION (X) ON ATTACK ANGLE 90, H/C = 0.25

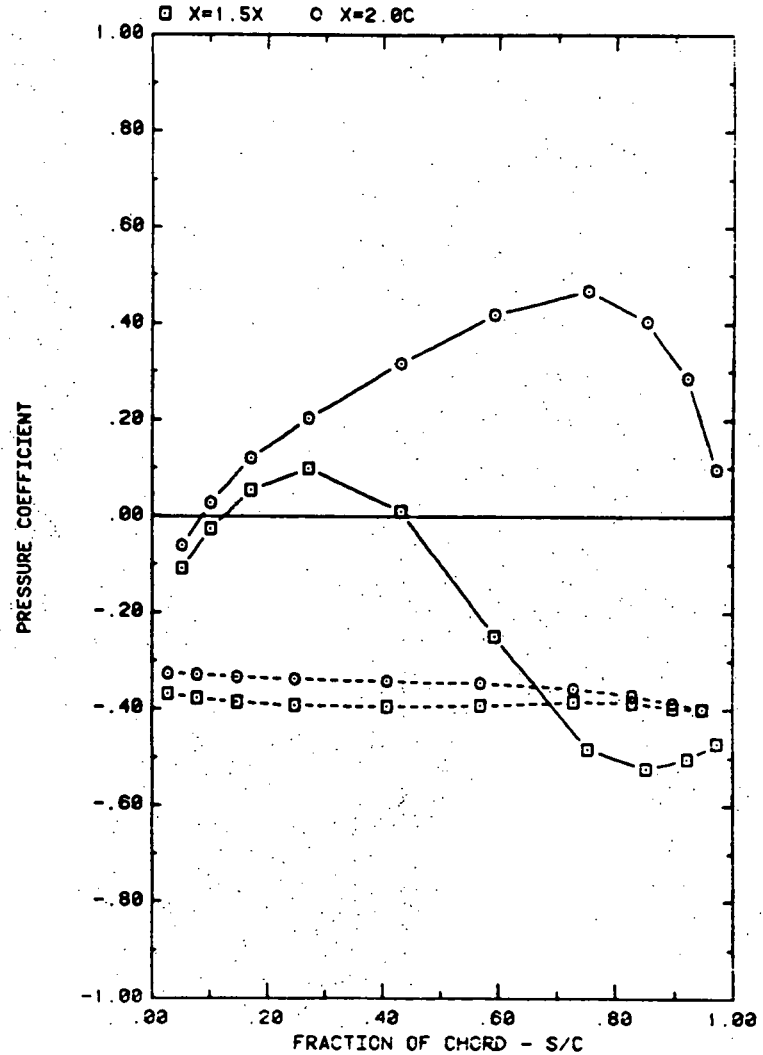

FRONT AND BACK PRESSURES ON ARRAY #2 IN UNIFORM FLOW
EFFECT OF SEPARATION (X) ON ATTACK ANGLE 20, H/C = 0.25

Plot 2-1-2. (Continued)

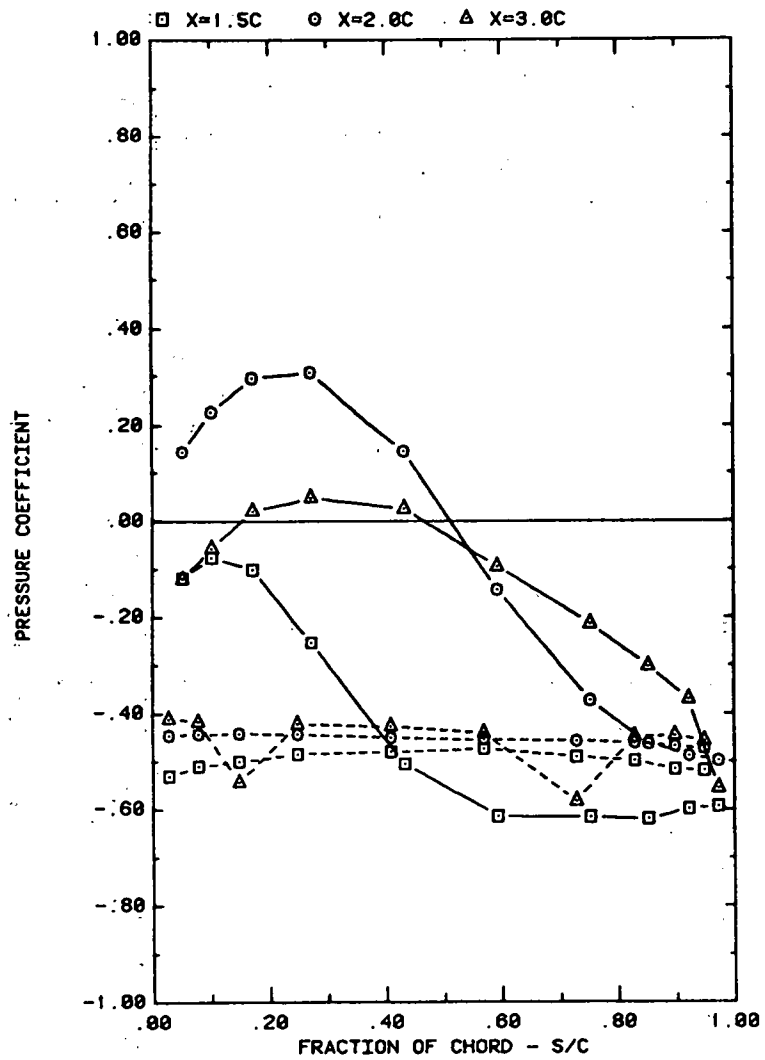

FRONT AND BACK PRESSURES ON ARRAY #2 IN UNIFORM FLOW
EFFECT OF SEPARATION (X) ON ATTACK ANGLE 35, H/C = 0.25

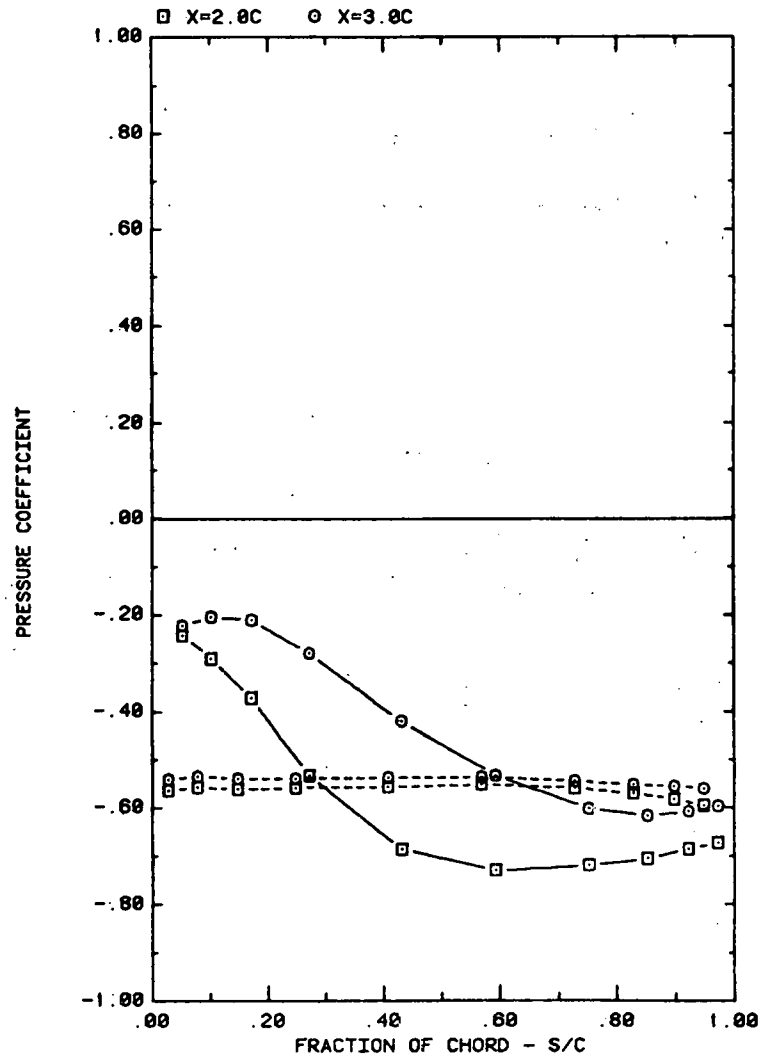

FRONT AND BACK PRESSURES ON ARRAY #2 IN UNIFORM FLOW
EFFECT OF SEPARATION (X) ON ATTACK ANGLE 60, H/C = 0.25

Plot 2-1-2. (Continued)

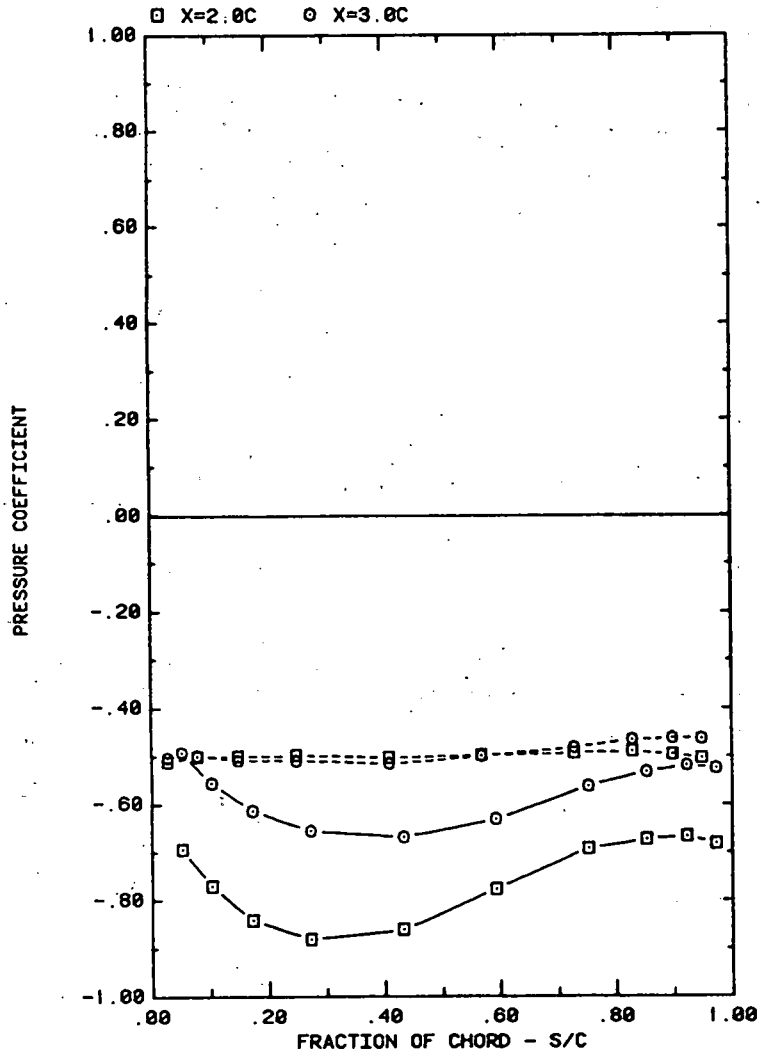

FRONT AND BACK PRESSURES ON ARRAY #2 IN UNIFORM FLOW
EFFECT OF SEPARATION (X) ON ATTACK ANGLE 120, H/C = 0.25

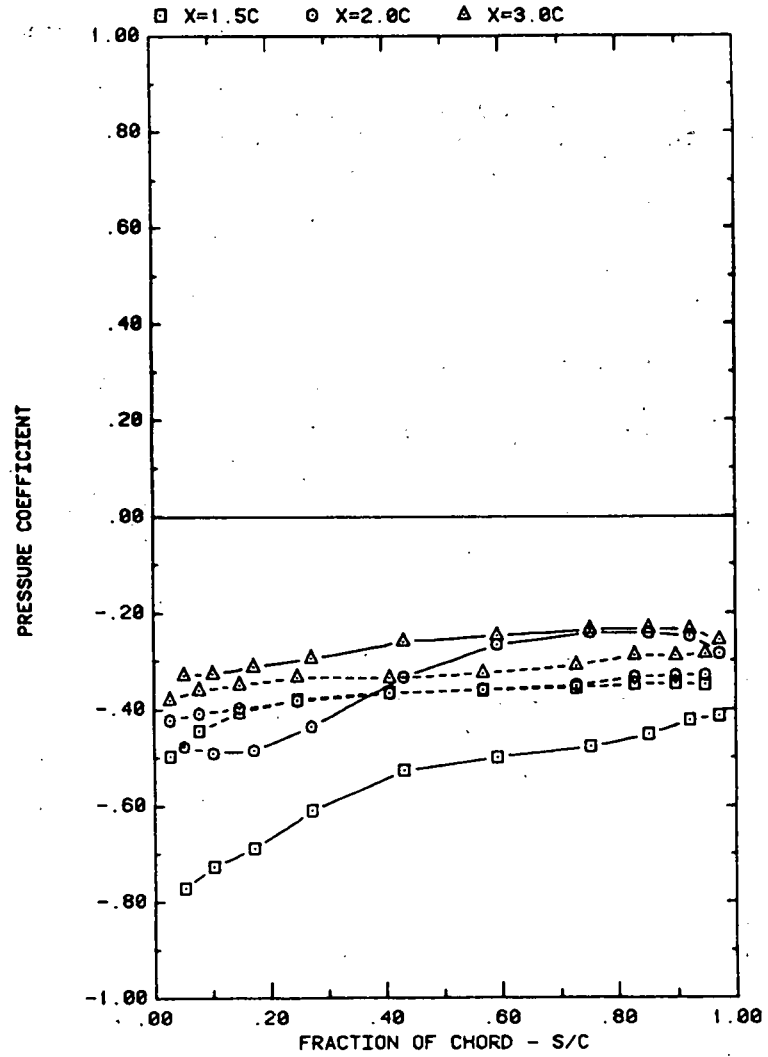

FRONT AND BACK PRESSURES ON ARRAY #2 IN UNIFORM FLOW
EFFECT OF SEPARATION (X) ON ATTACK ANGLE 145, H/C = 0.25

Plot 2-1-2. (Continued)

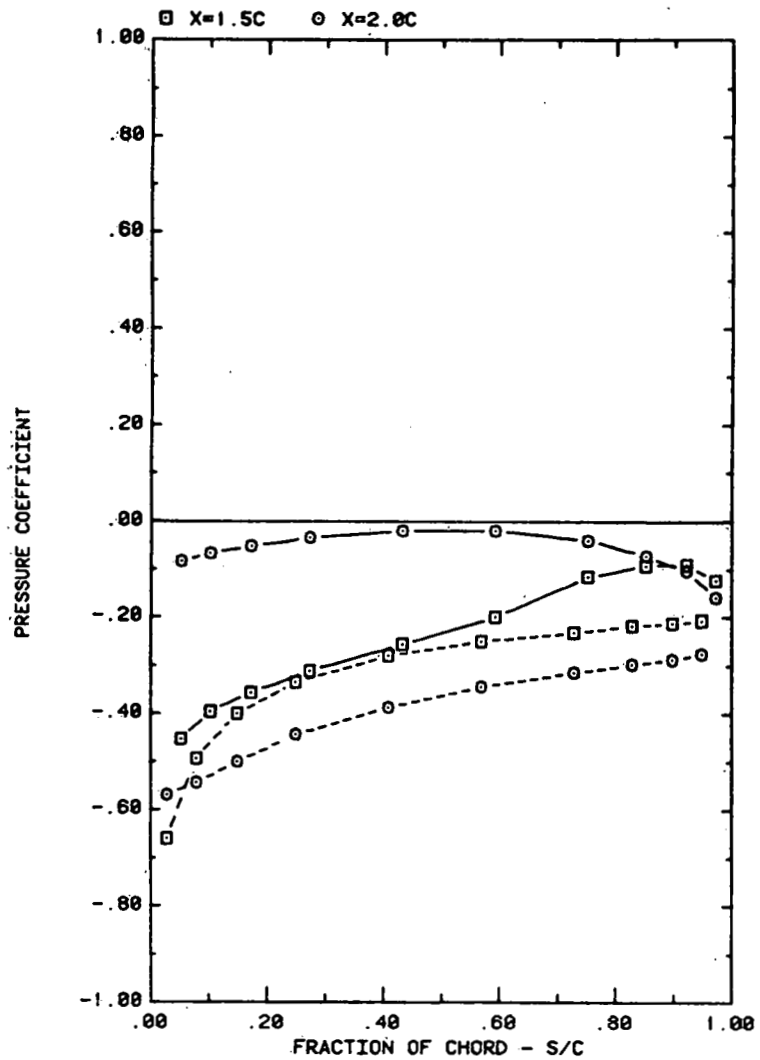

FRONT AND BACK PRESSURES ON ARRAY #2 IN UNIFORM FLOW.
EFFECT OF SEPARATION (X) ON ATTACK ANGLE 160, H/C = 0.25

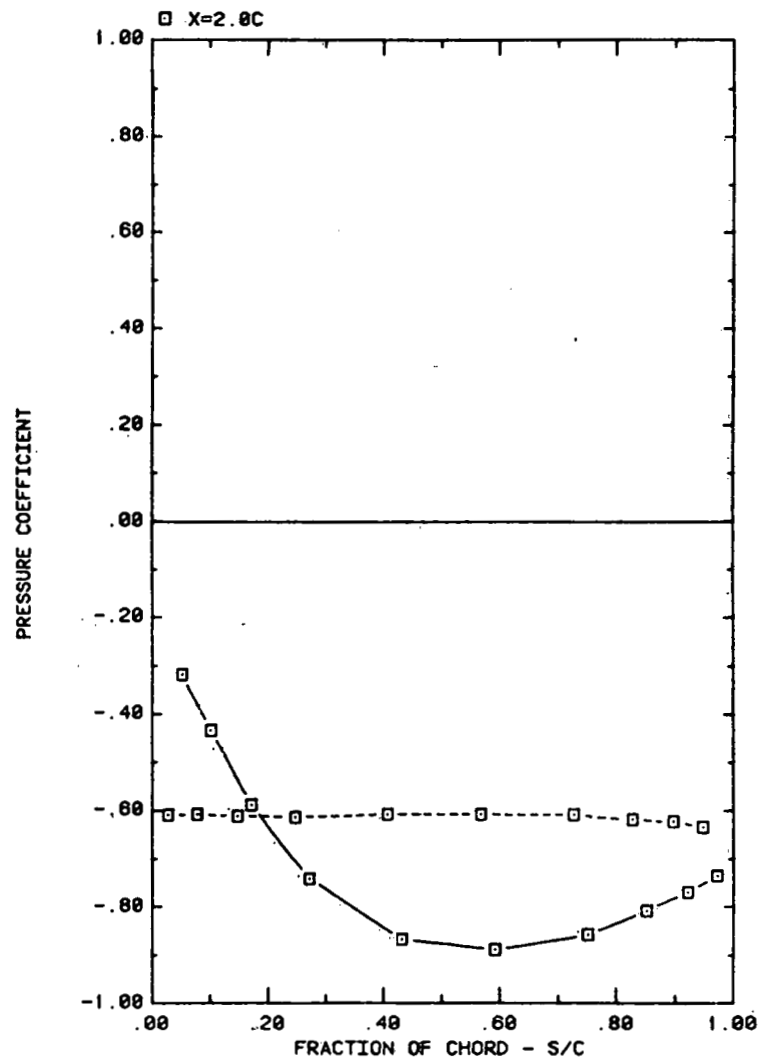

FRONT AND BACK PRESSURES ON ARRAY #2 IN UNIFORM FLOW.
EFFECT OF SEPARATION (X) ON ATTACK ANGLE 90, H/C = 0.25

Plot 2-1-2. (Continued)

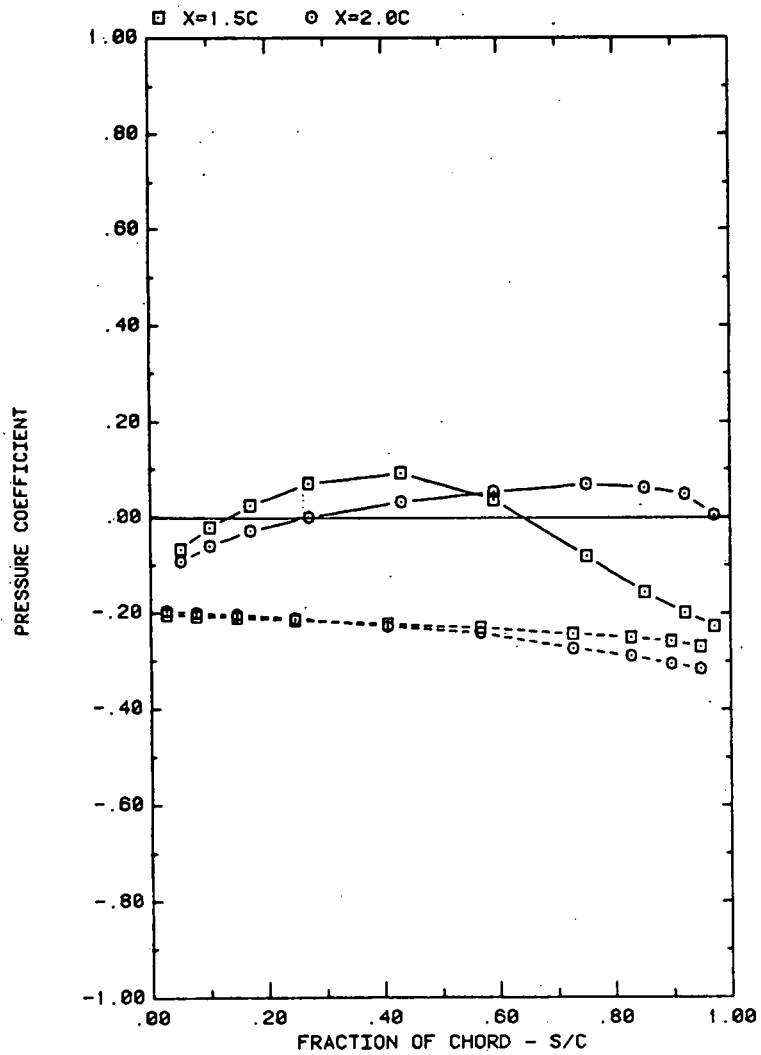

FRONT AND BACK PRESSURES ON ARRAY #5 IN UNIFORM FLOW
EFFECT OF SEPARATION (X) ON ATTACK ANGLE 20, H/C = 0.25

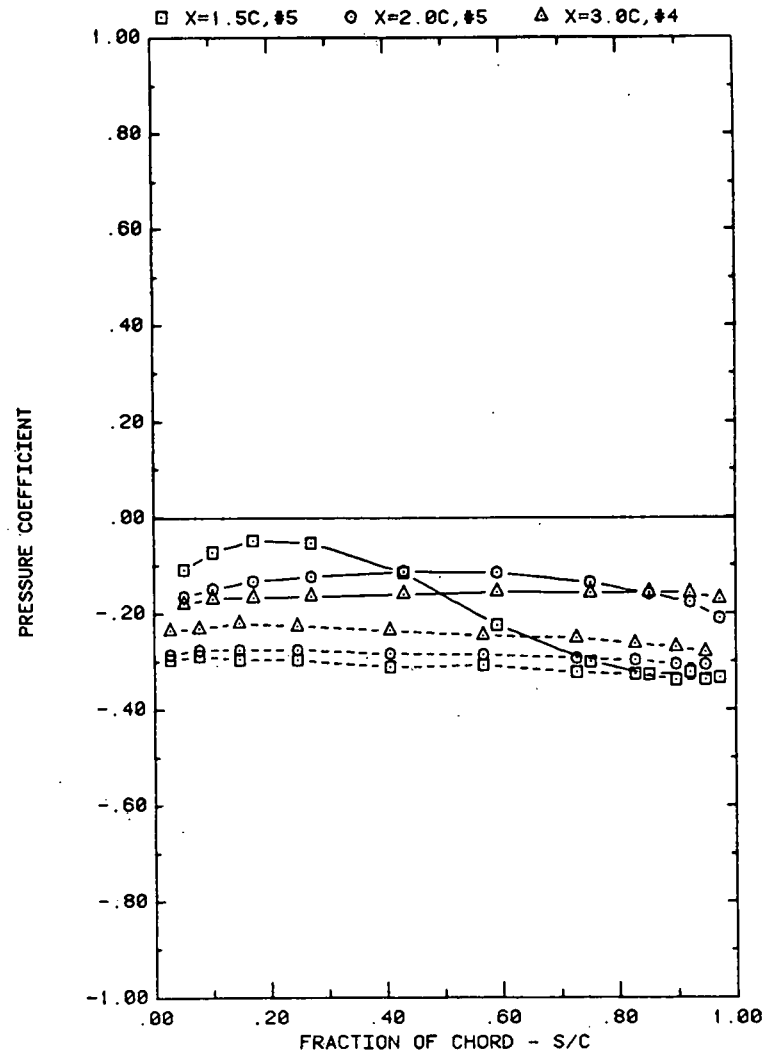

FRONT AND BACK PRESSURES ON ARRAY #4 OR #5 IN UNIFORM FLOW
EFFECT OF SEPARATION (X) ON ATTACK ANGLE 35, H/C = 0.25

Plot 2-1-2. (Continued)

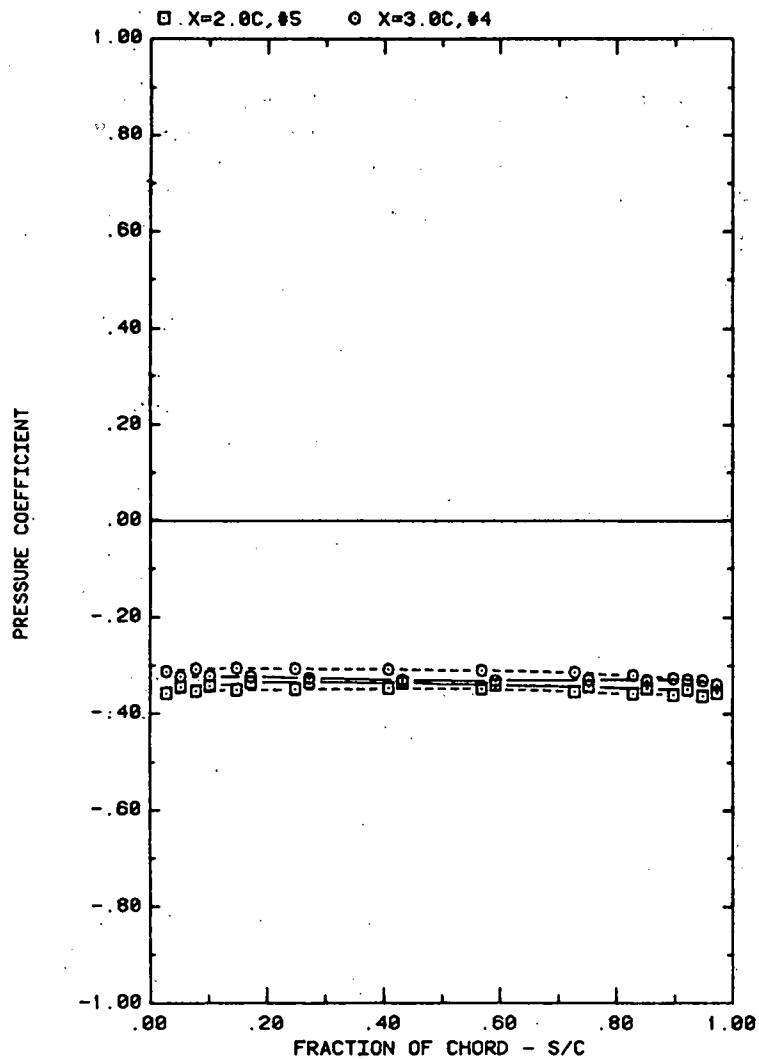

FRONT AND BACK PRESSURES ON ARRAY #4 OR #5 IN UNIFORM FLOW-
EFFECT OF SEPARATION (X) ON ATTACK ANGLE 60, H/C = 0.25

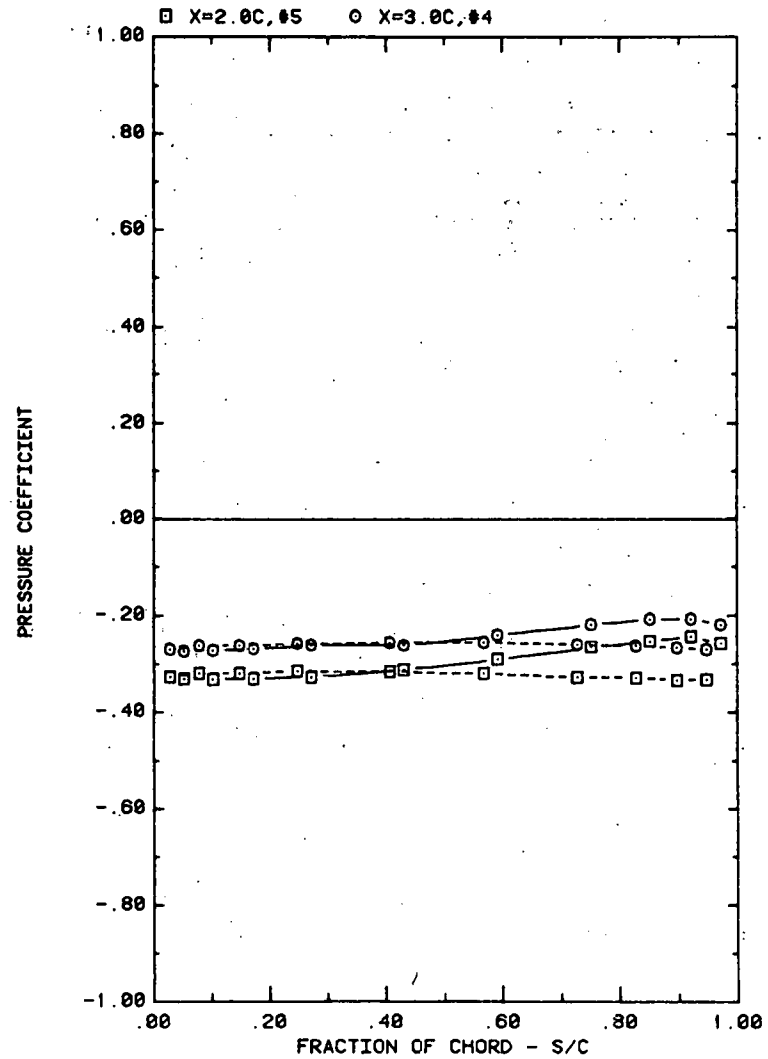

FRONT AND BACK PRESSURES ON ARRAY #4 OF #5 IN UNIFORM FLOW
EFFECT OF SEPARATION (X) ON ATTACK ANGLE 20, H/C = 0.25

Plot 2-1-2. (Continued)

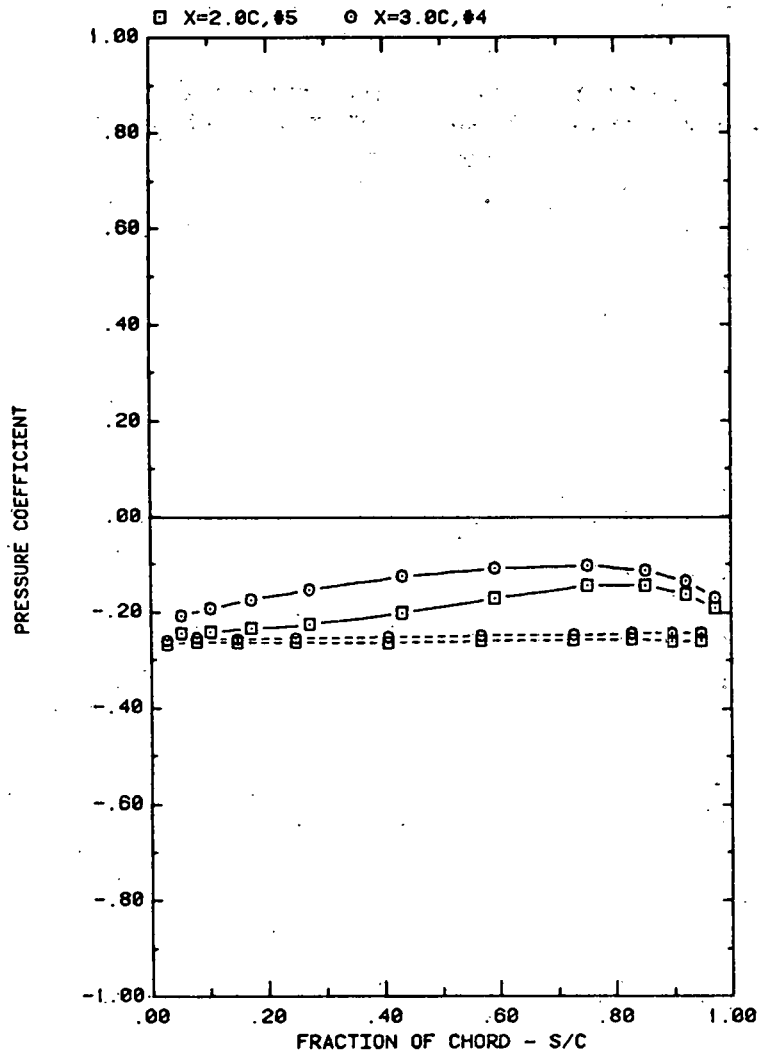

FRONT AND BACK PRESSURES ON ARRAY #4 OR #5 IN UNIFORM FLOW
EFFECT OF SEPARATION (X) ON ATTACK ANGLE 145, H/C = 0.25

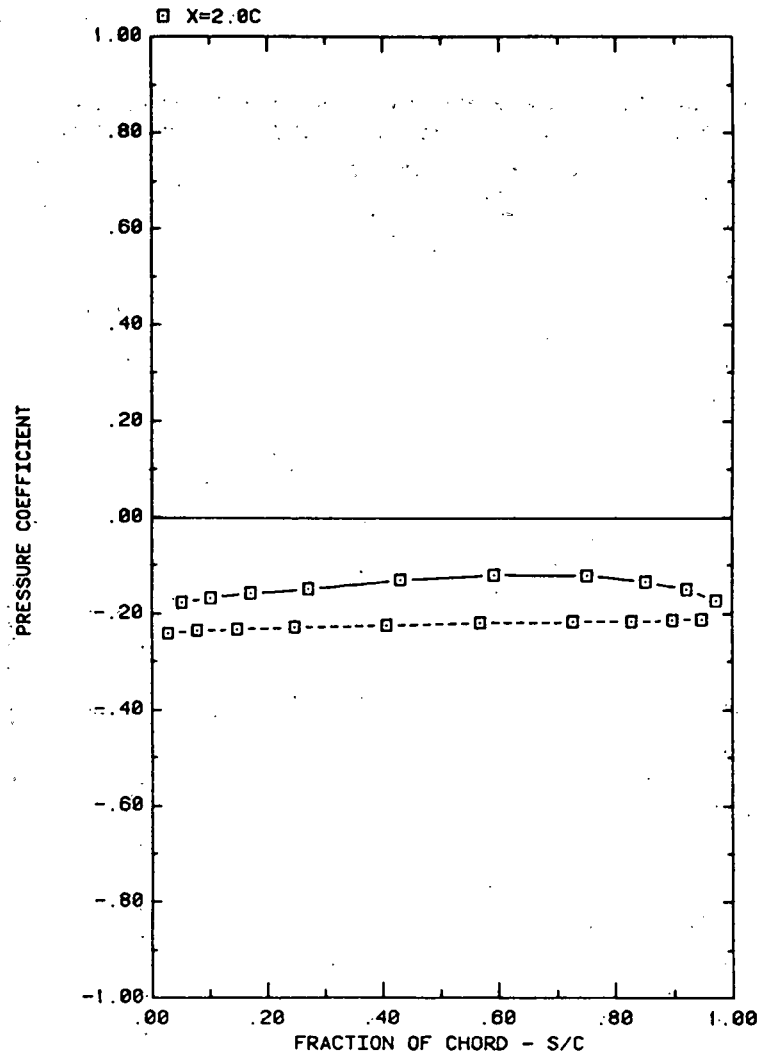

FRONT AND BACK PRESSURES ON ARRAY #5 IN UNIFORM FLOW
EFFECT OF SEPARATION (X) ON ATTACK ANGLE 160, H/C = 0.25

Plot 2-1-2. (Continued)

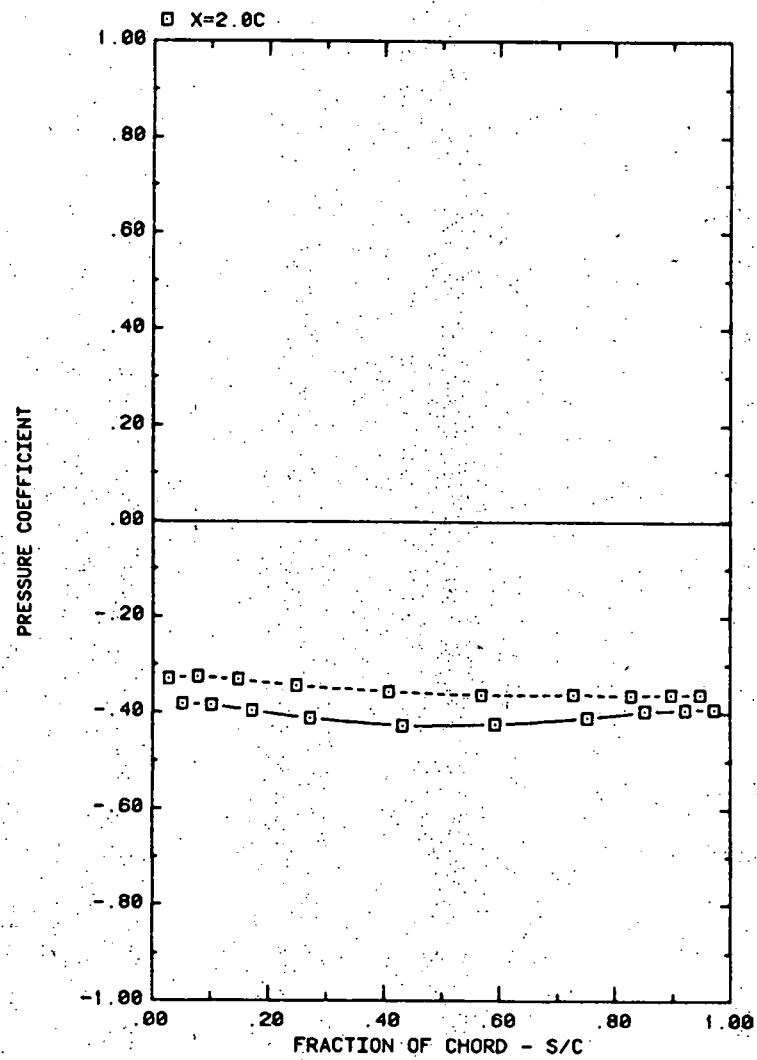

FRONT AND BACK PRESSURES ON ARRAY #5 IN UNIFORM FLOW
EFFECT OF SEPARATION (X) ON ATTACK ANGLE 90, H/C = 0.25

Plot 2-1-2. (Concluded)

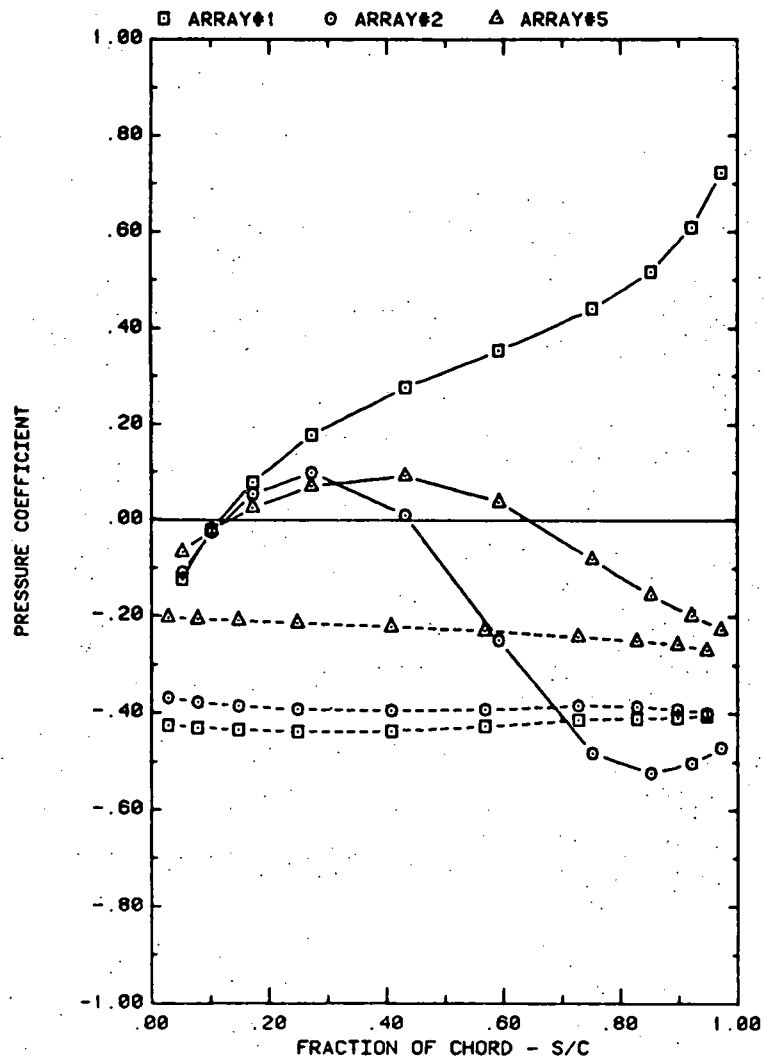

FRONT AND BACK PRESSURES ON VARIOUS ARRAYS FOR SEPARATION = 1.5C
 EFFECT OF ARRAY CONFIGURATION FOR ATTACK ANGLE, ALPHA = 20

Plot 2-1-3. Multiple Arrays without Fence, Uniform Flow Study
 Effect of Array Position

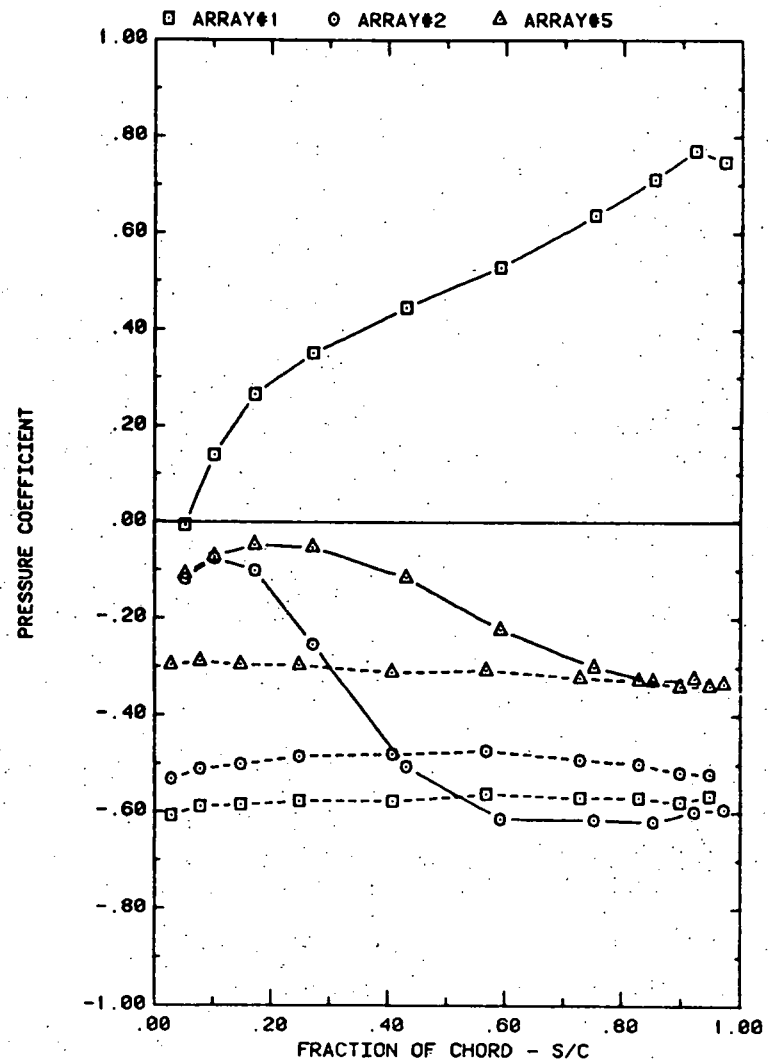

FRONT AND BACK PRESSURES ON VARIOUS ARRAYS FOR SEPARATION = 1.5C
 EFFECT OF ARRAY CONFIGURATION FOR ATTACK ANGLE, ALPHA = 35

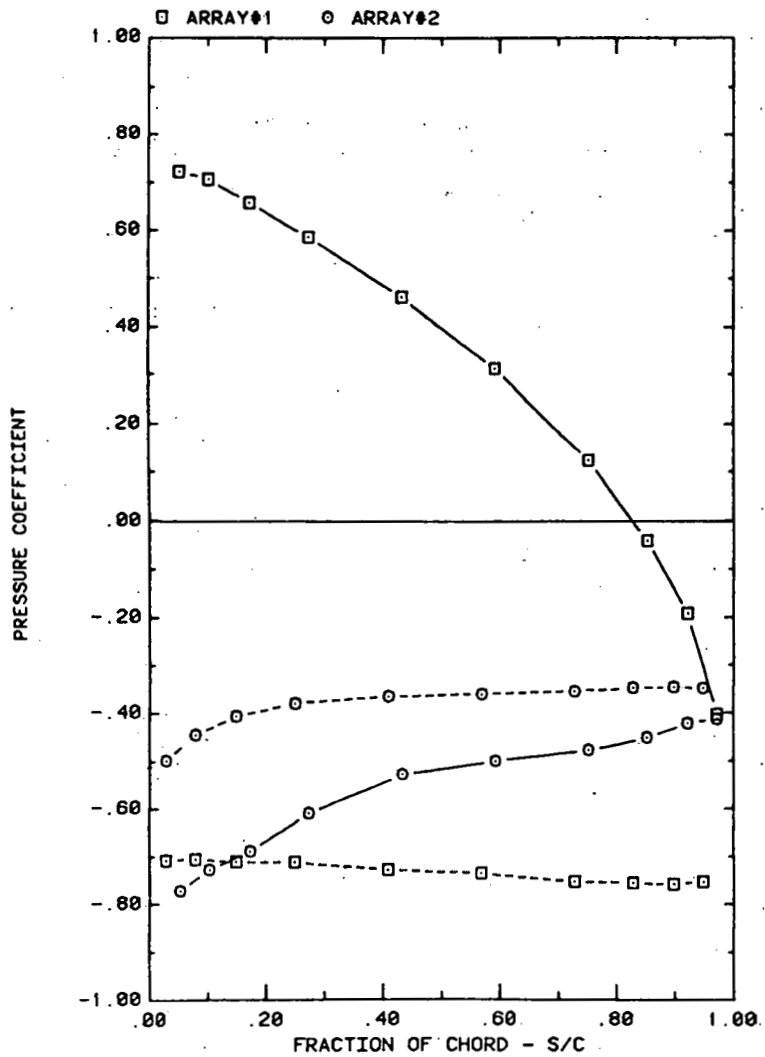

FRONT AND BACK PRESSURES ON VARIOUS ARRAYS FOR SEPARATION = 1.5C
EFFECT OF ARRAY CONFIGURATION FOR ATTACK ANGLE, $\alpha = 145$

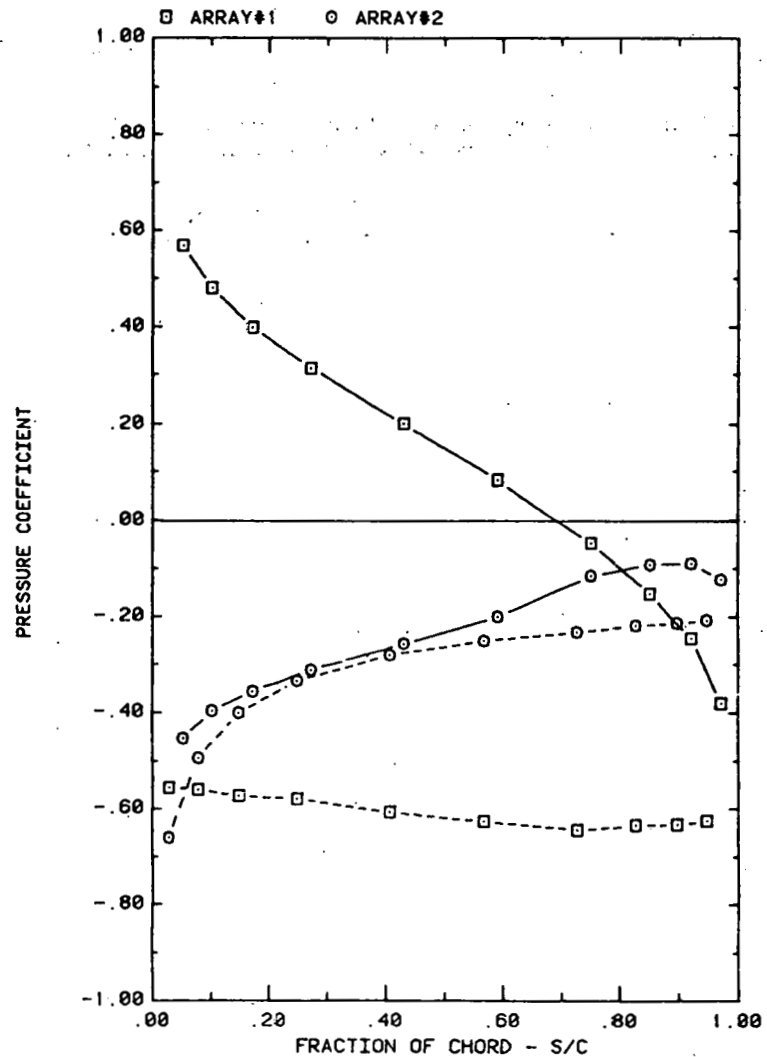

FRONT AND BACK PRESSURES ON VARIOUS ARRAYS FOR SEPARATION = 1.5C
EFFECT OF ARRAY CONFIGURATION FOR ATTACK ANGLE, $\alpha = 160$

Plot 2-1-3. (Continued)

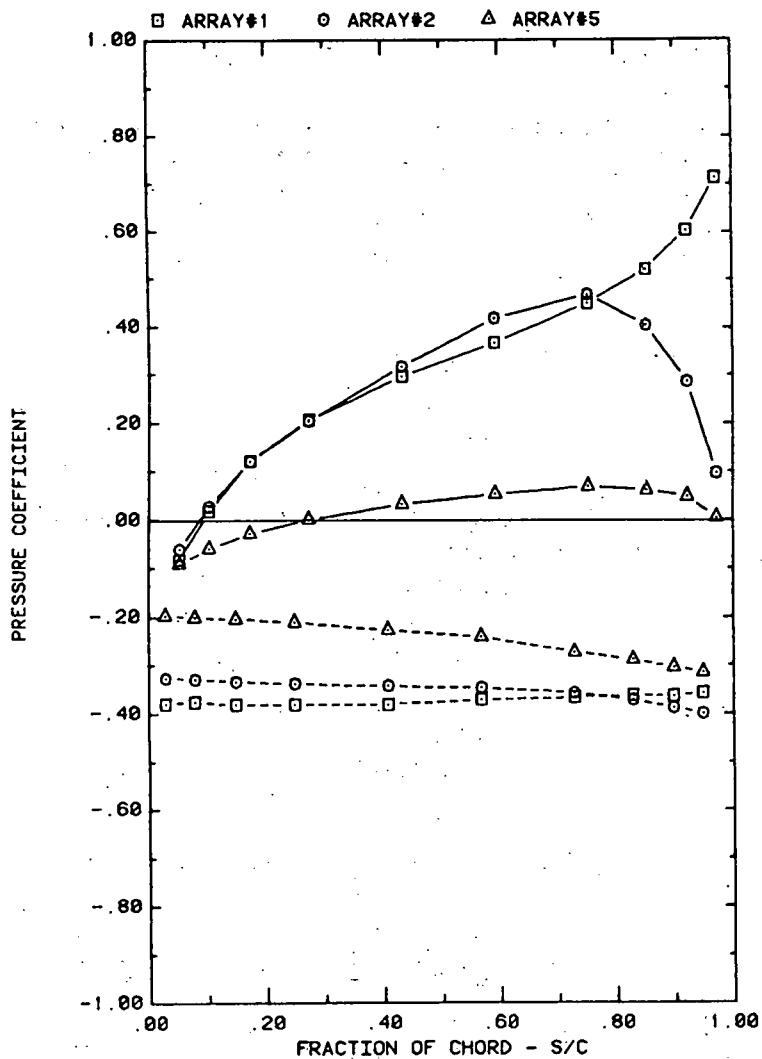

FRONT AND BACK PRESSURES ON VARIOUS ARRAYS FOR SEPARATION = 2C
EFFECT OF ARRAY CONFIGURATION FOR ATTACK ANGLE, ALPHA = 20

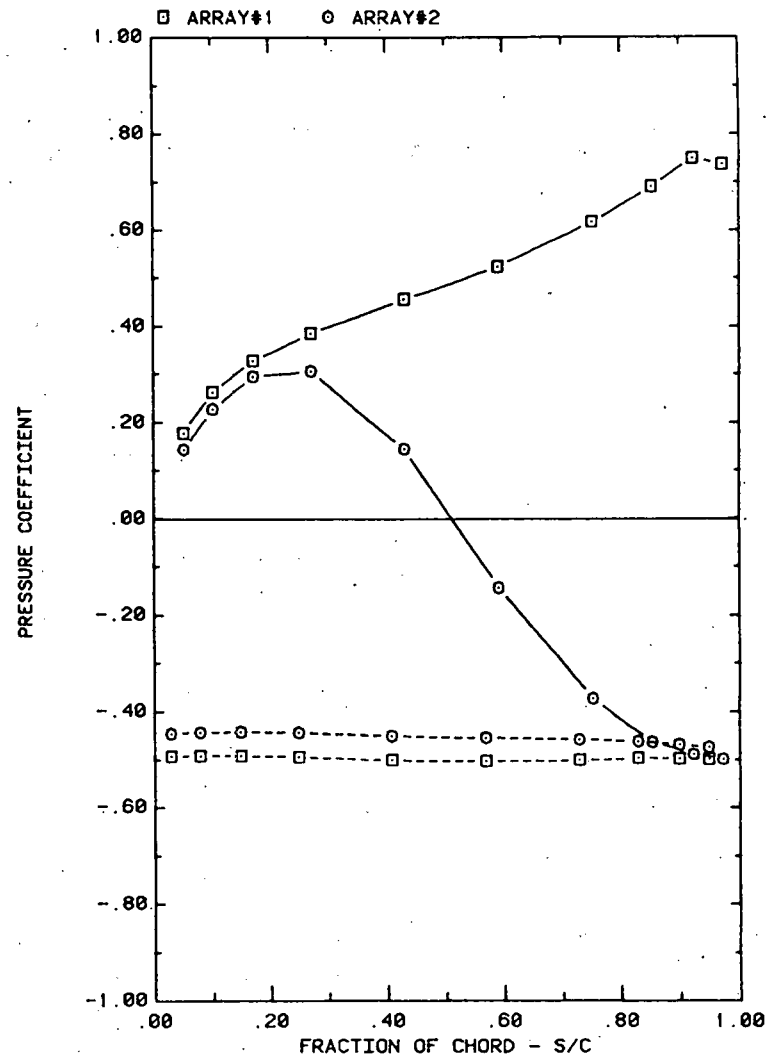

FRONT AND BACK PRESSURES ON VARIOUS ARRAYS FOR SEPARATION = 2C
EFFECT OF ARRAY CONFIGURATION FOR ATTACK ANGLE, ALPHA = 35

Plot 2-1-3. (Continued)

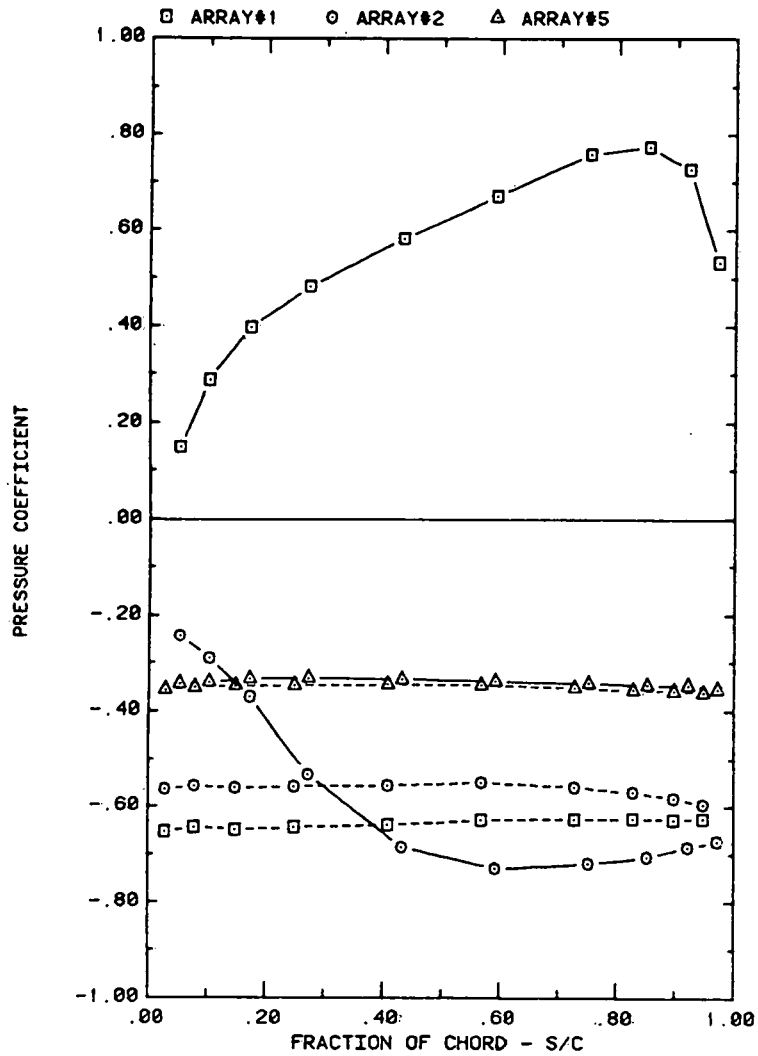

FRONT AND BACK PRESSURES ON VARIOUS ARRAYS FOR SEPARATION = 2C
EFFECT OF ARRAY CONFIGURATION FOR ATTACK ANGLE, ALPHA = 60

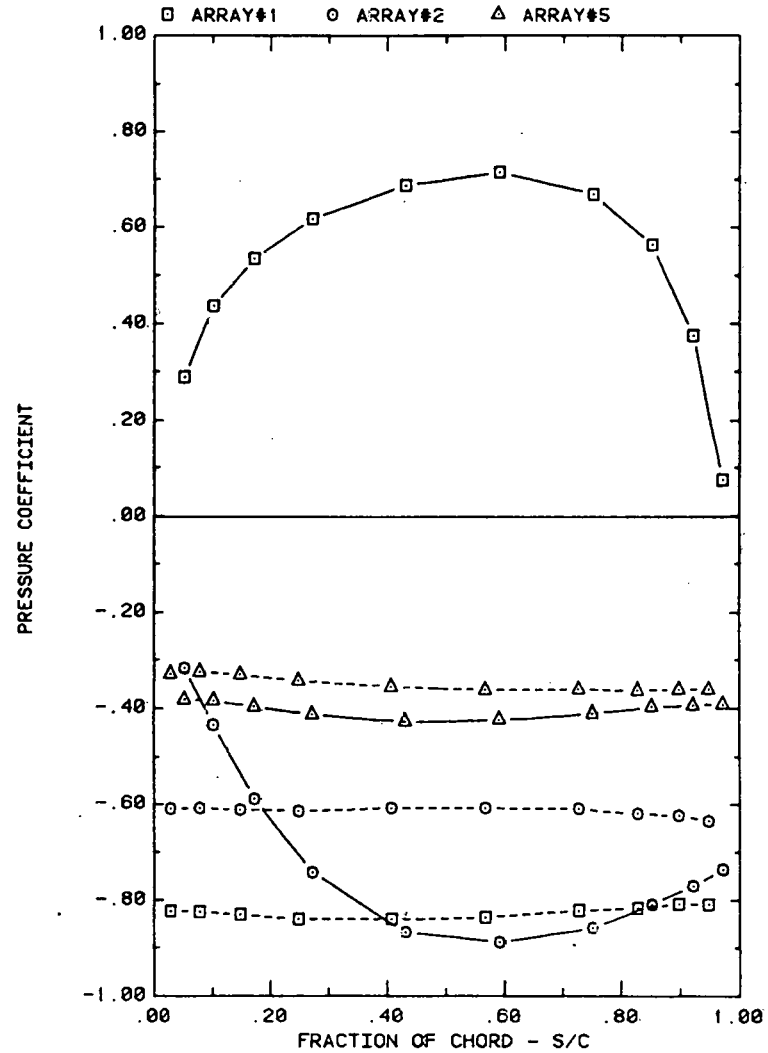

FRONT AND BACK PRESSURES ON VARIOUS ARRAYS FOR SEPARATION = 2C
EFFECT OF ARRAY CONFIGURATION FOR ATTACK ANGLE, ALPHA = 90

Plot 2-1-3. (Continued)

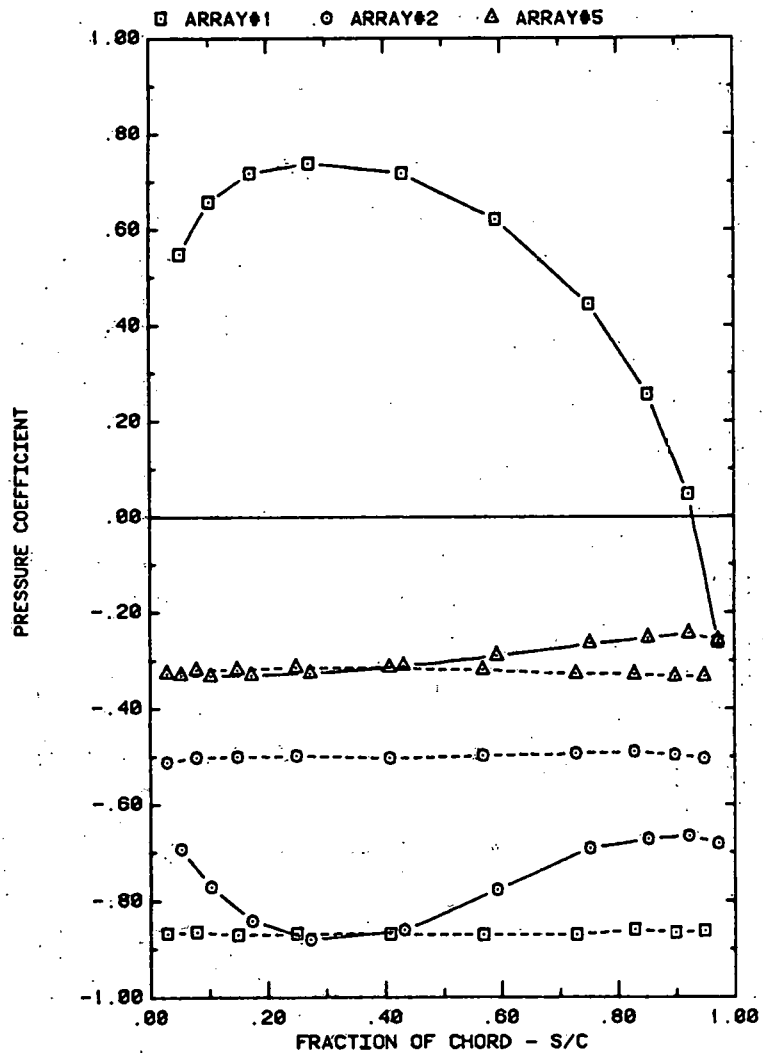

FRONT AND BACK PRESSURES ON VARIOUS ARRAYS FOR SEPARATION = 2C
EFFECT OF ARRAY CONFIGURATION FOR ATTACK ANGLE, $\alpha = 120$

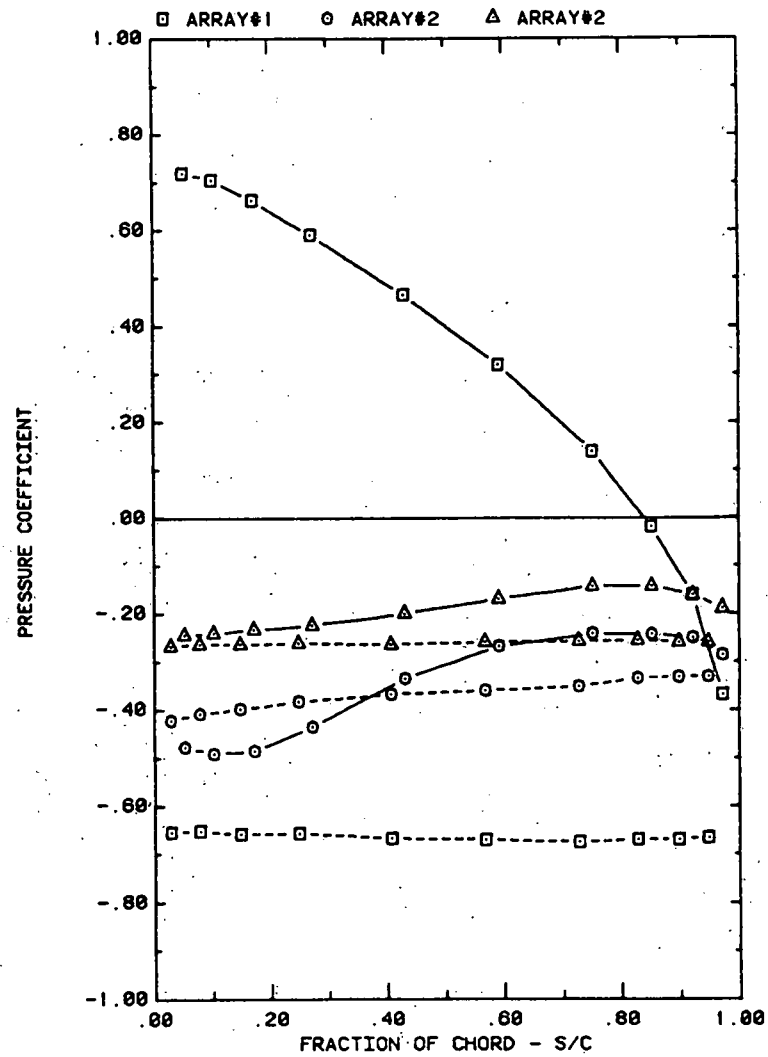

FRONT AND BACK PRESSURES ON VARIOUS ARRAYS FOR SEPARATION = 2C
EFFECT OF ARRAY CONFIGURATION FOR ATTACK ANGLE, $\alpha = 145$

Plot 2-1-3. (Continued)

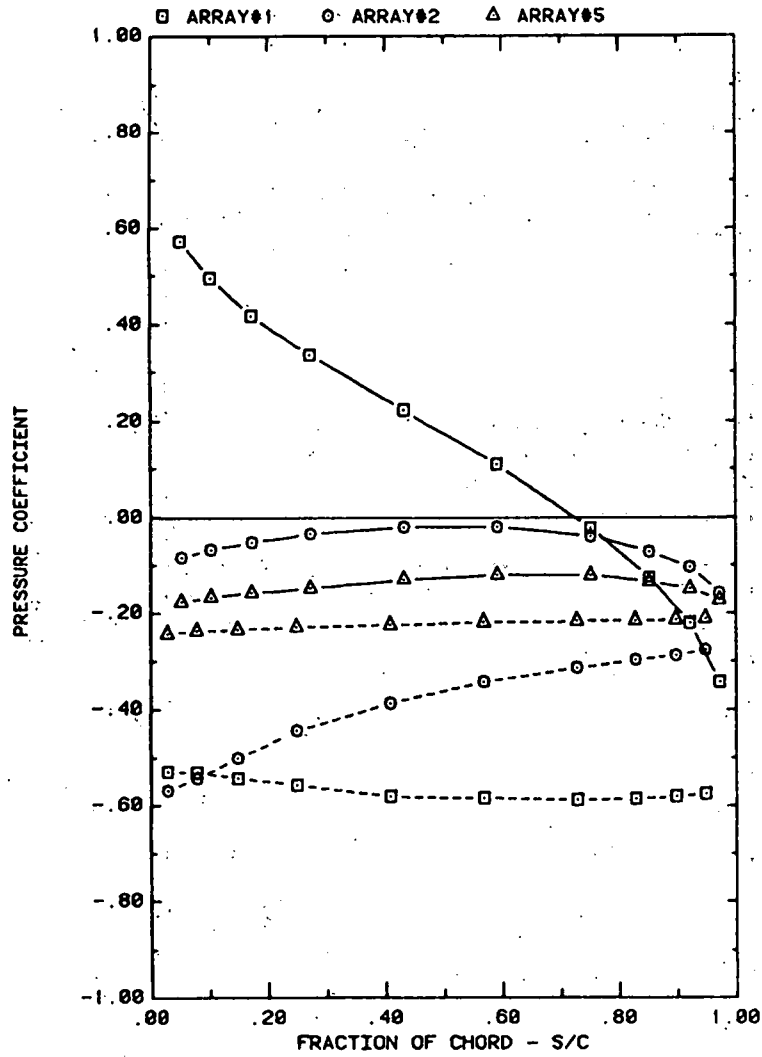

FRONT AND BACK PRESSURES ON VARIOUS ARRAYS FOR SEPARATION = 2C
EFFECT OF ARRAY CONFIGURATION FOR ATTACK ANGLE, ALPHA = 160

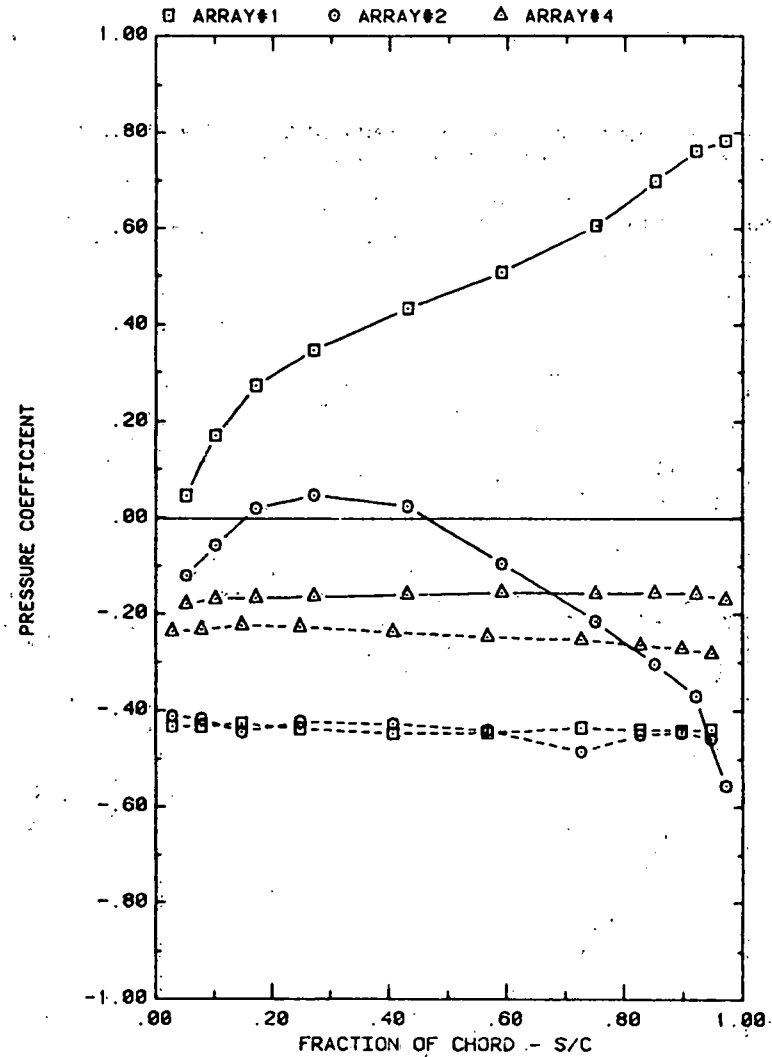

FRONT AND BACK PRESSURES ON VARIOUS ARRAYS FOR SEPARATION = 3C
EFFECT OF ARRAY CONFIGURATION FOR ATTACK ANGLE, ALPHA = 35

Plot 2-1-3. (Continued).

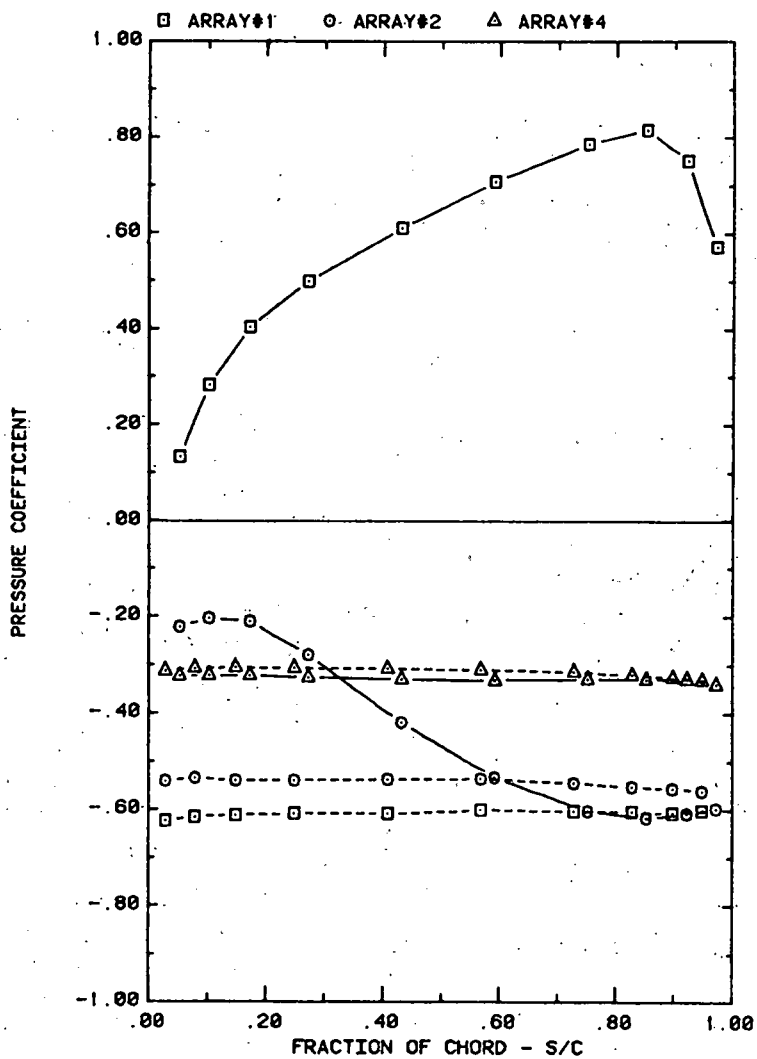

FRONT AND BACK PRESSURES ON VARIOUS ARRAYS FOR SEPARATION = 3C
EFFECT OF ARRAY CONFIGURATION FOR ATTACK ANGLE, ALPHA = 60

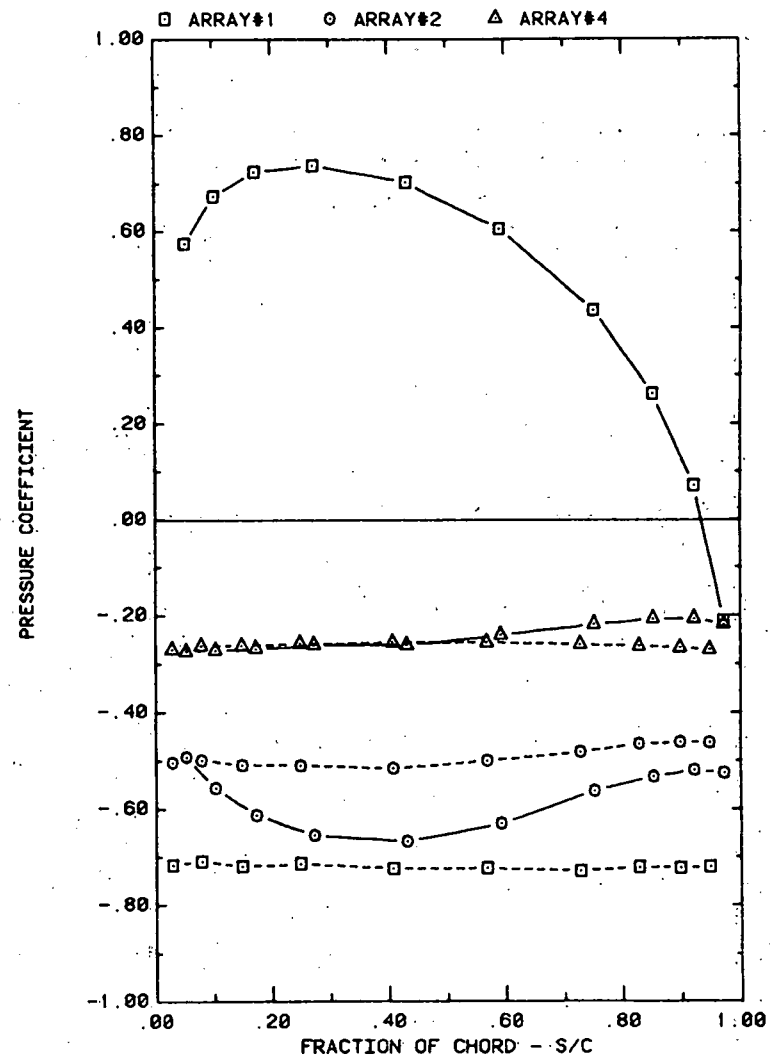

FRONT AND BACK PRESSURES ON VARIOUS ARRAYS FOR SEPARATION = 3C
EFFECT OF ARRAY CONFIGURATION FOR ATTACK ANGLE, ALPHA = 120

Plot 2-1-3. (Continued)

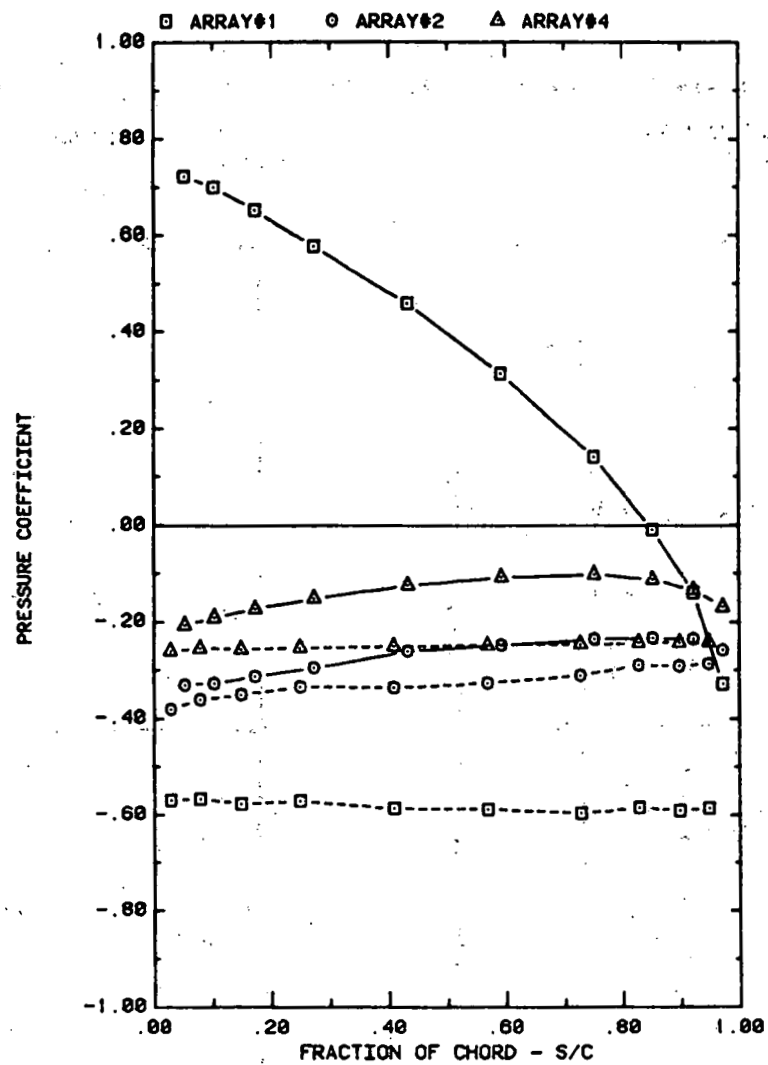

FRONT AND BACK PRESSURES ON VARIOUS ARRAYS FOR SEPARATION = 3C
EFFECT OF ARRAY CONFIGURATION FOR ATTACK ANGLE, ALPHA = 145

Plot 2-1-3. (Concluded)

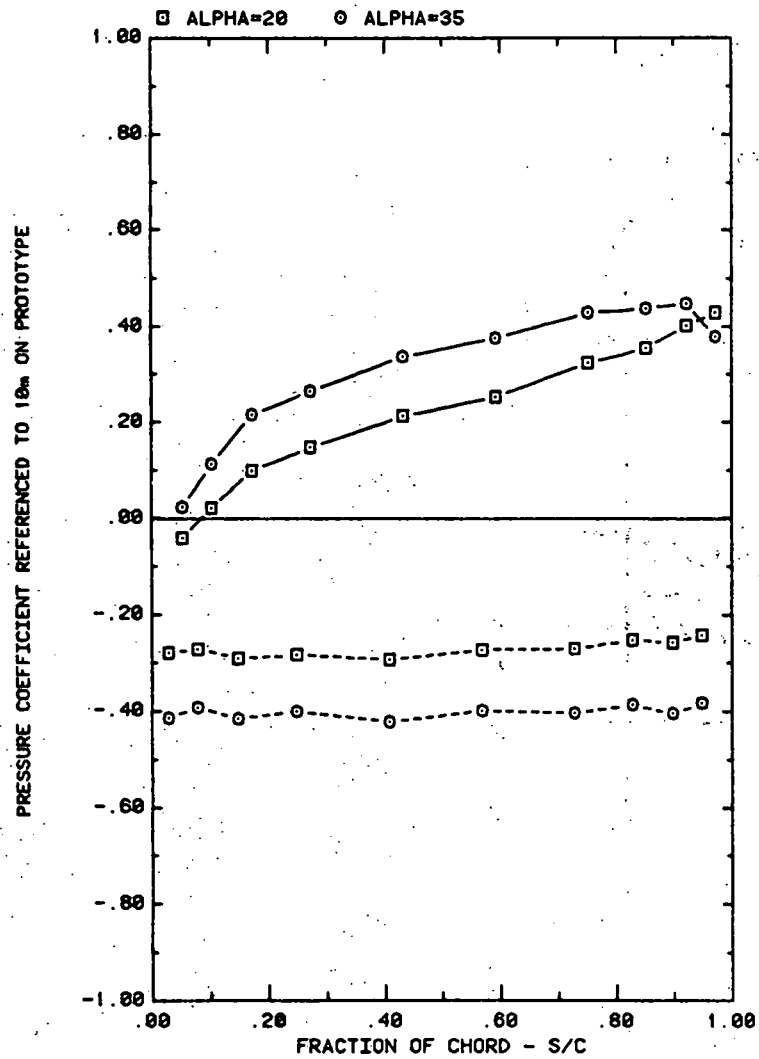

FRONT AND BACK PRESSURES ON ARRAY #1 IN BOUNDARY LAYER
EFFECT OF ATTACK ANGLE FOR SPACING = 1.5C

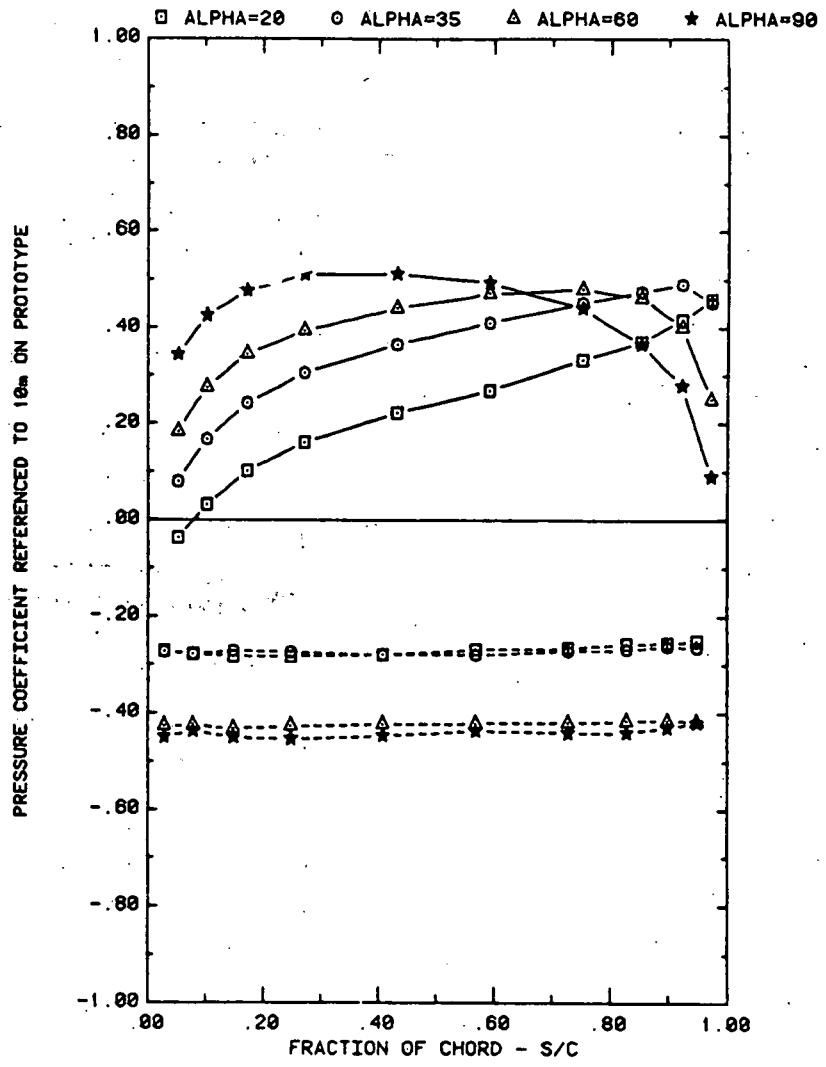

FRONT AND BACK PRESSURES ON ARRAY #1 IN BOUNDARY LAYER
EFFECT OF ATTACK ANGLE FOR SPACING = 2C

Plot 2-2-1. Multiple Arrays without Fence, Nonuniform Flow
Study Effect of Angle of Attack

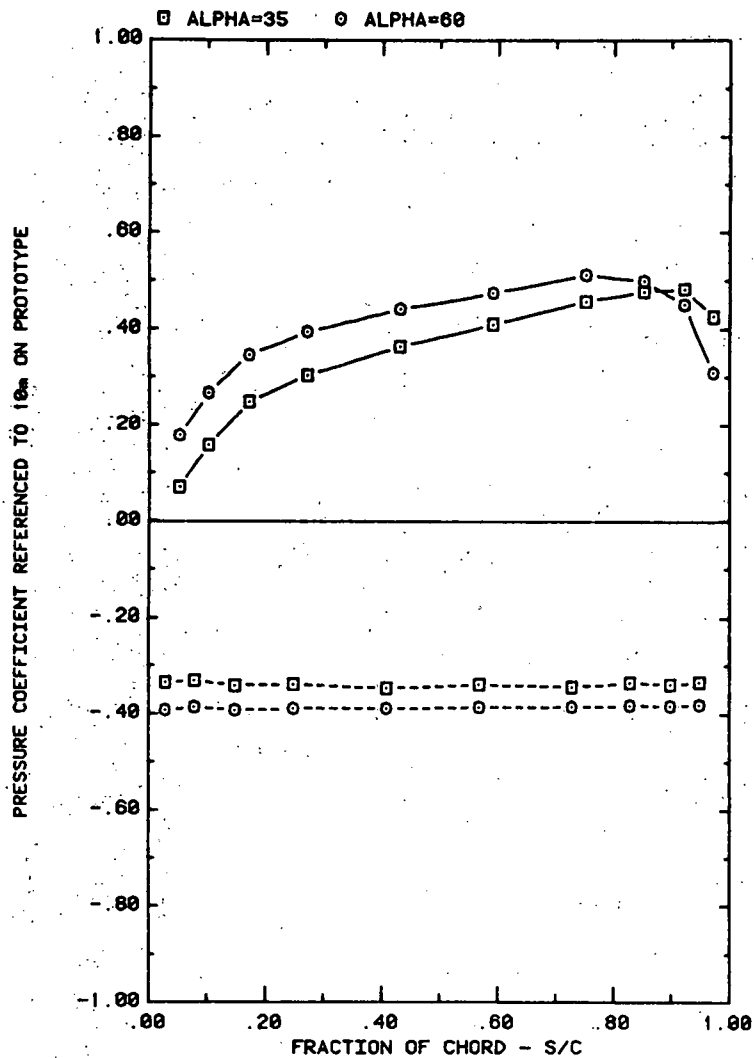

FRONT AND BACK PRESSURES ON ARRAY #1 IN BOUNDARY LAYER
EFFECT OF ATTACK ANGLE FOR SPACING = 3C

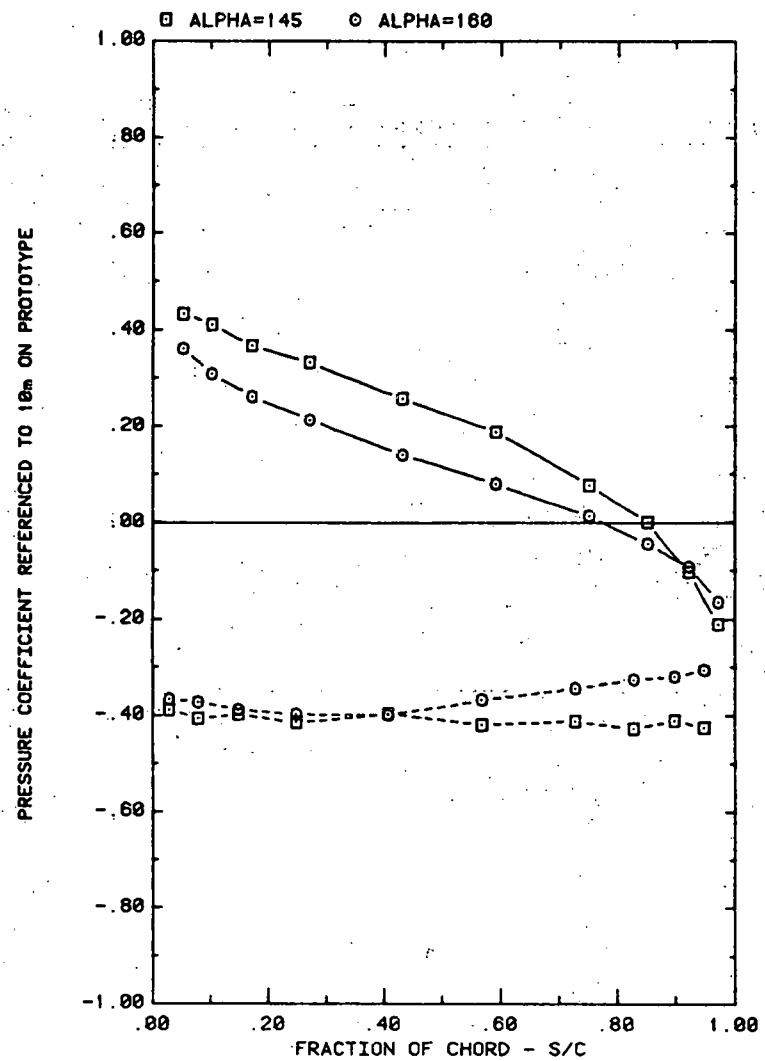

FRONT AND BACK PRESSURES ON ARRAY #1 IN BOUNDARY LAYER
EFFECT OF ATTACK ANGLE FOR SPACING = 1.5C

Plot 2-2-1. (Continued)

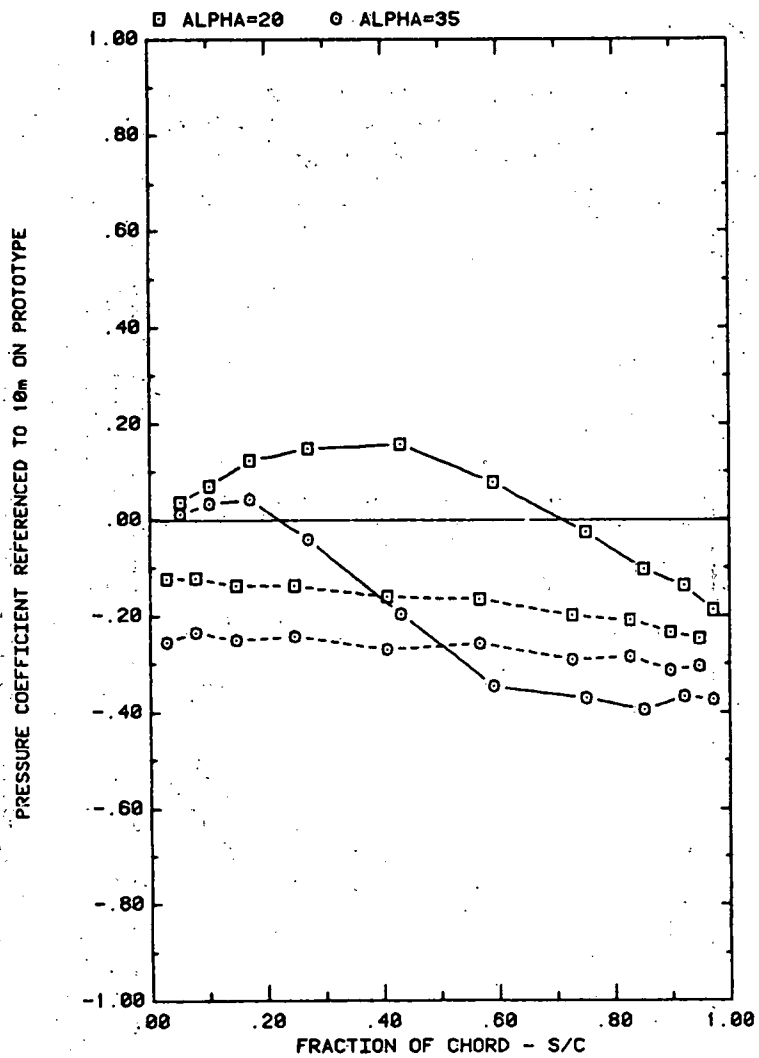

FRONT AND BACK PRESSURES ON ARRAY #2 IN BOUNDARY LAYER
EFFECT OF ATTACK ANGLE FOR SPACING = 1.5C

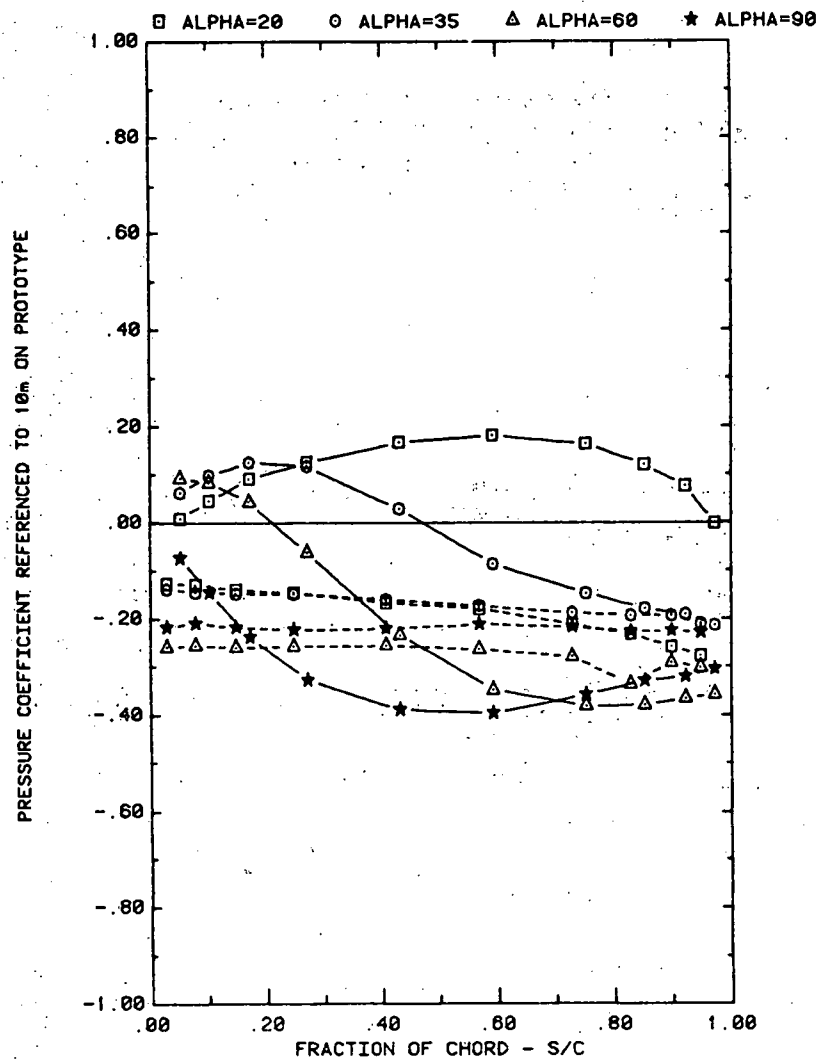

FRONT AND BACK PRESSURES ON ARRAY #2 IN BOUNDARY LAYER
EFFECT OF ATTACK ANGLE FOR SPACING = 2C

Plot 2-2-1. (Continued)

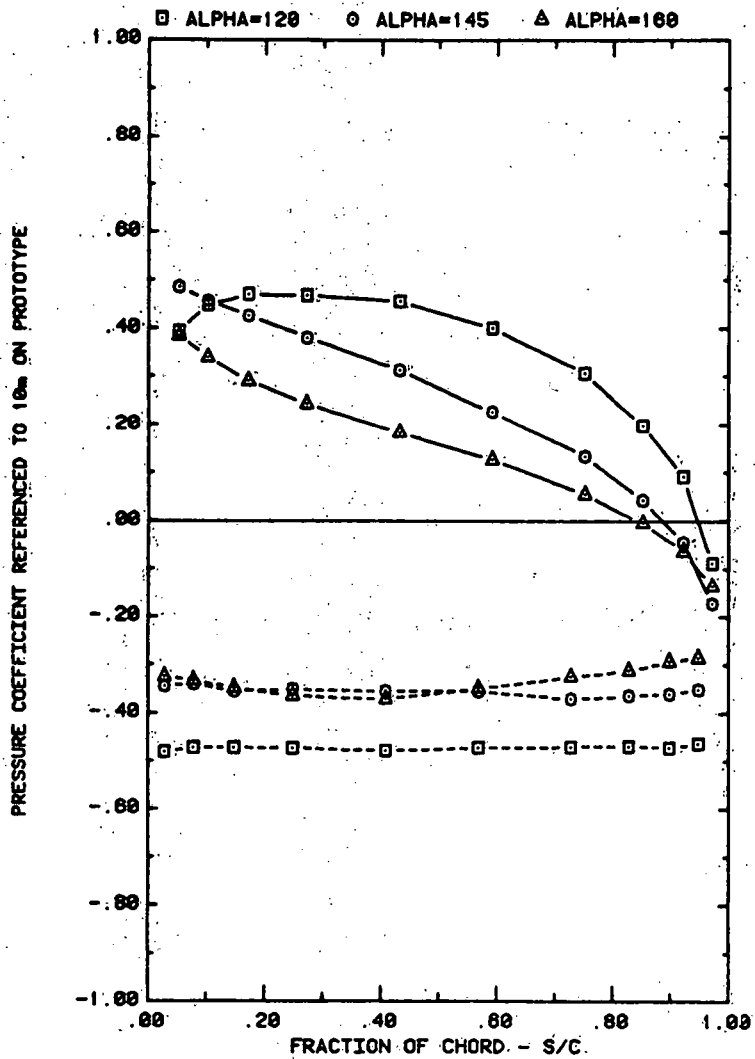

FRONT AND BACK PRESSURES ON ARRAY #1 IN BOUNDARY LAYER
EFFECT OF ATTACK ANGLE FOR SPACING = 2C

Plot 2-2-1. (Continued)

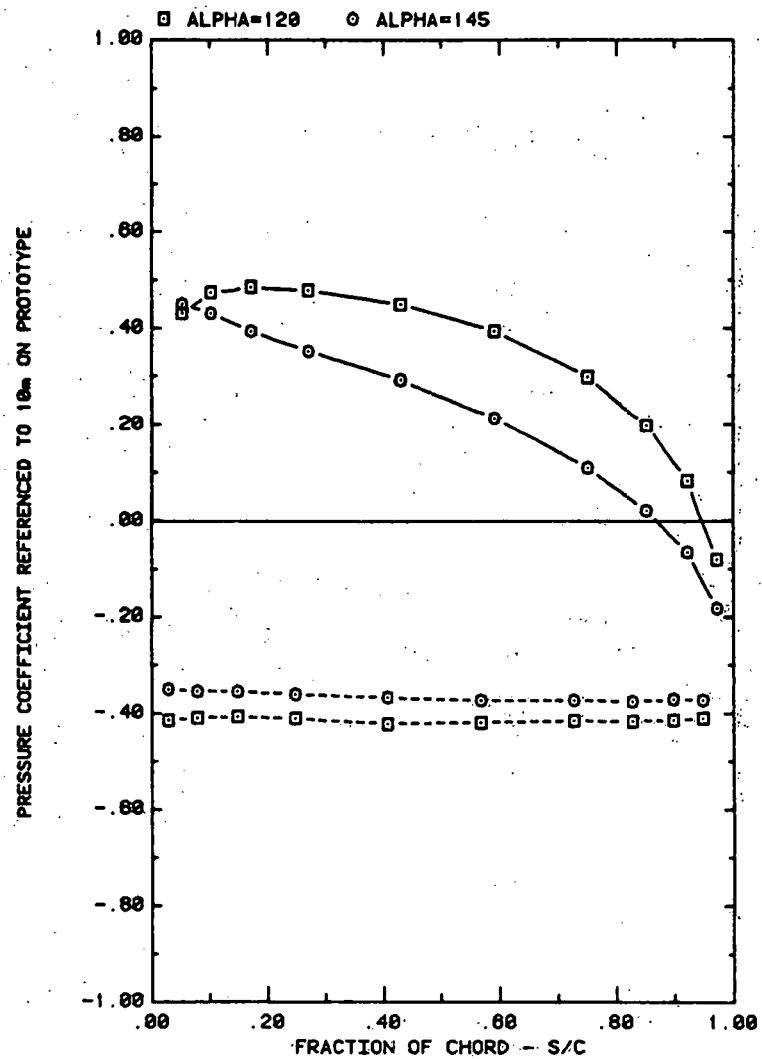

FRONT AND BACK PRESSURES ON ARRAY #1 IN BOUNDARY LAYER
EFFECT OF ATTACK ANGLE FOR SPACING = 3C

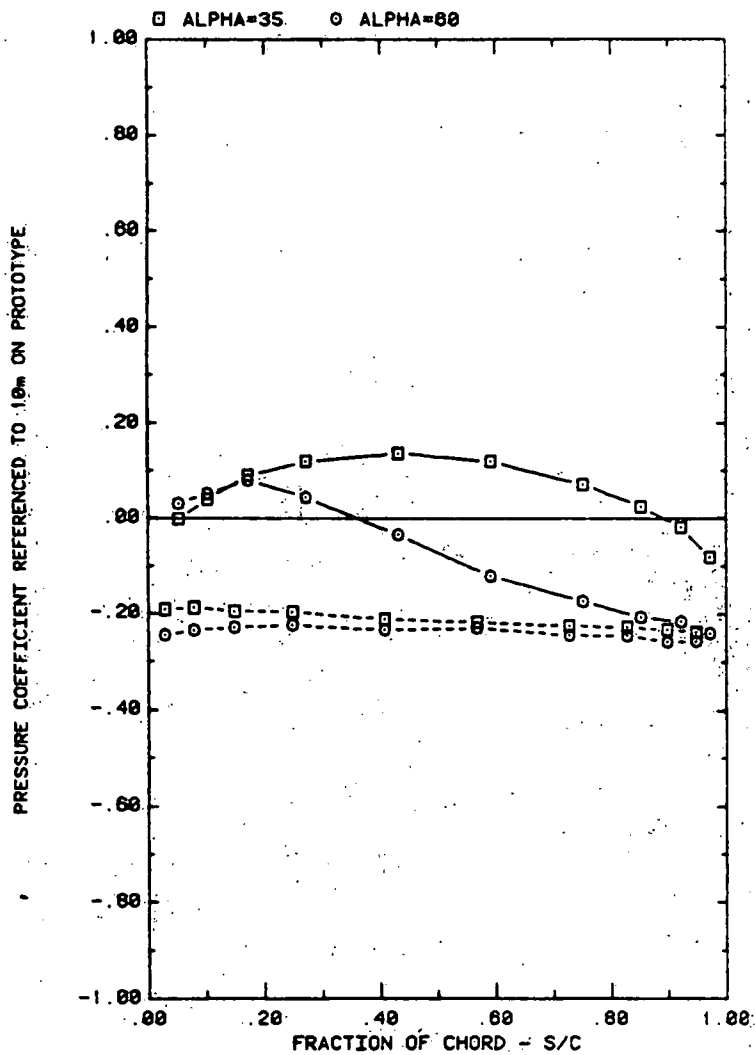

FRONT AND BACK PRESSURES ON ARRAY #2 IN BOUNDARY LAYER
EFFECT OF ATTACK ANGLE FOR SPACING = 3C

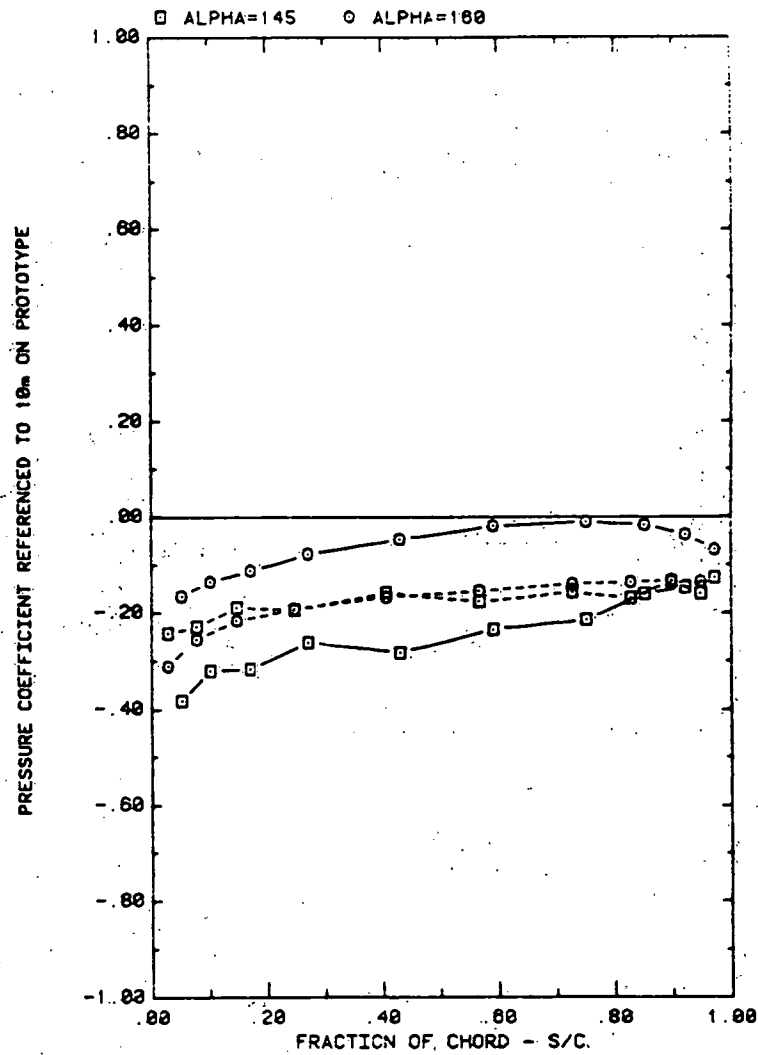

FRONT AND BACK PRESSURES ON ARRAY #2 IN BOUNDARY LAYER
EFFECT OF ATTACK ANGLE FOR SPACING = 1.5C

Plot 2-2-1. (Continued)

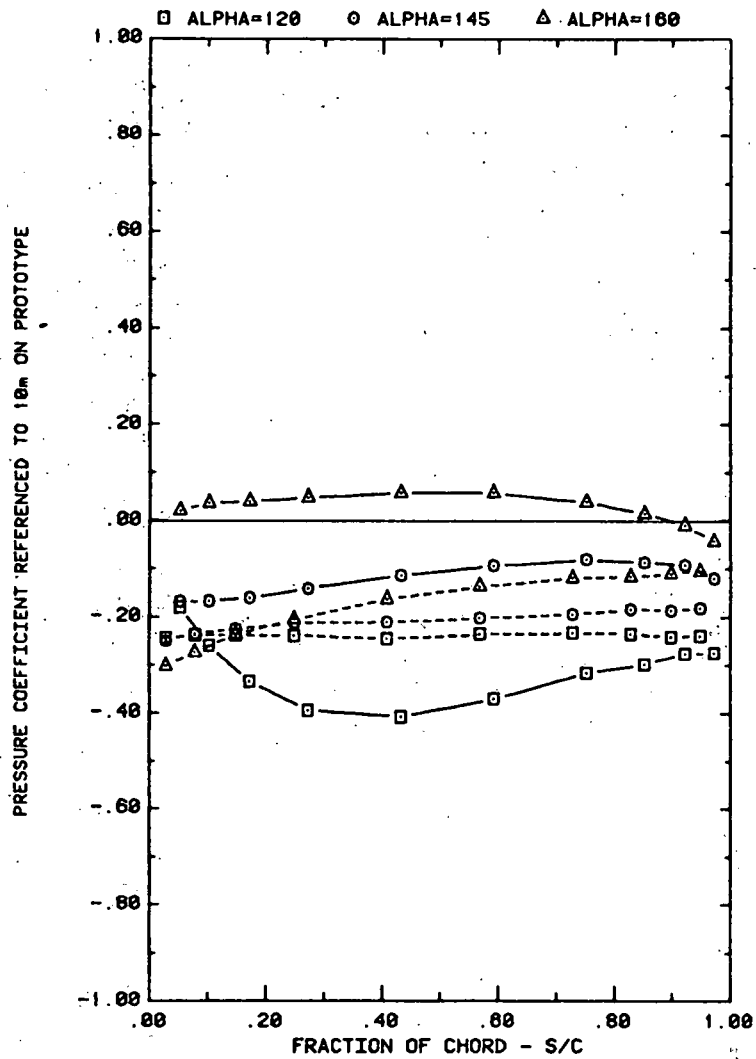

FRONT AND BACK PRESSURES ON ARRAY #2 IN BOUNDARY LAYER
EFFECT OF ATTACK ANGLE FOR SPACING = 2C

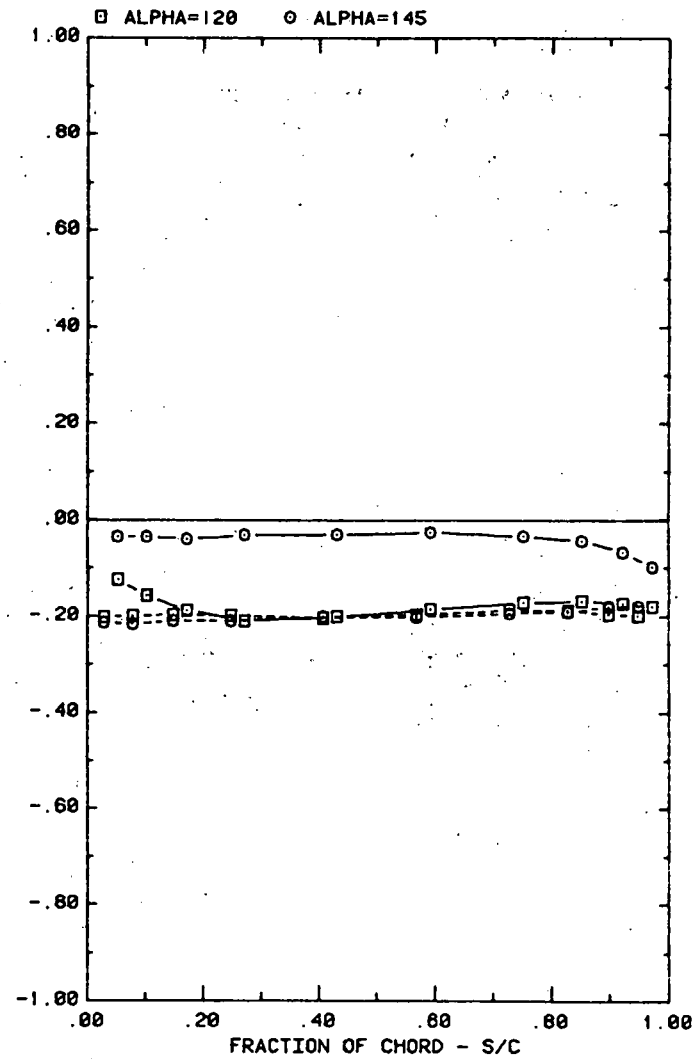

FRONT AND BACK PRESSURES ON ARRAY #2 IN BOUNDARY LAYER
EFFECT OF ATTACK ANGLE FOR SPACING = 3C

Plot 2-2-1. (Continued)

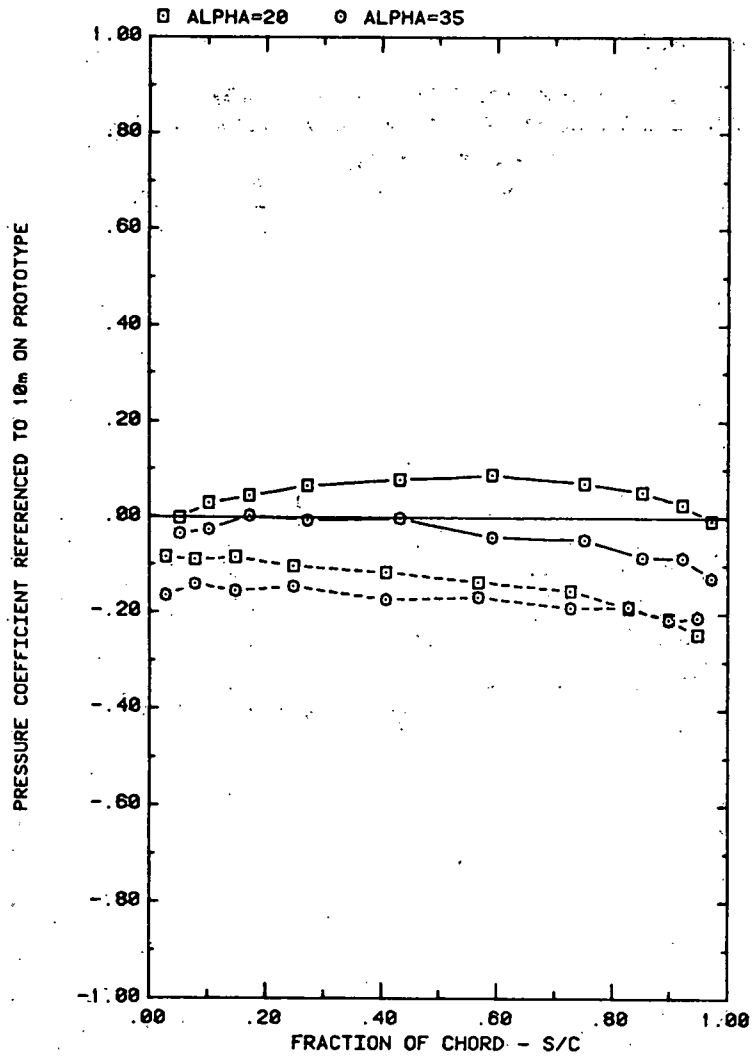

FRONT AND BACK PRESSURES ON ARRAY #5 IN BOUNDARY LAYER
EFFECT OF ATTACK ANGLE FOR SPACING = 1.5c

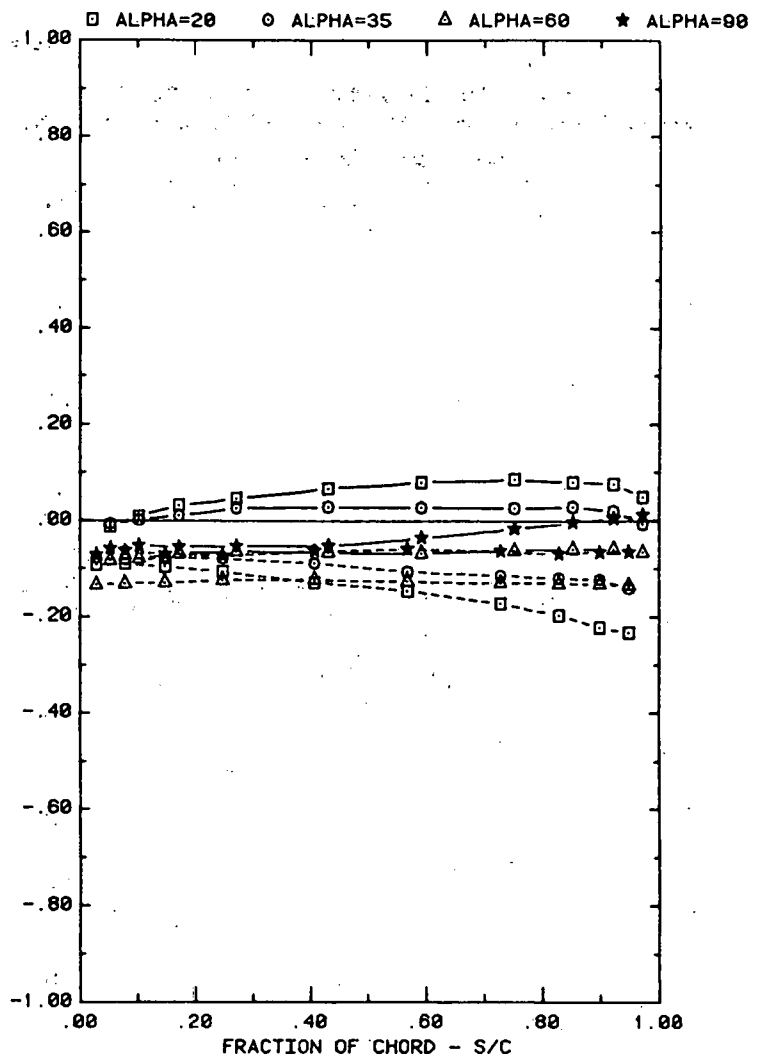

FRONT AND BACK PRESSURES ON ARRAY #5 IN BOUNDARY LAYER
EFFECT OF ATTACK ANGLE FOR SPACING = 2c

Plot 2-2-1. (Continued)

C-45

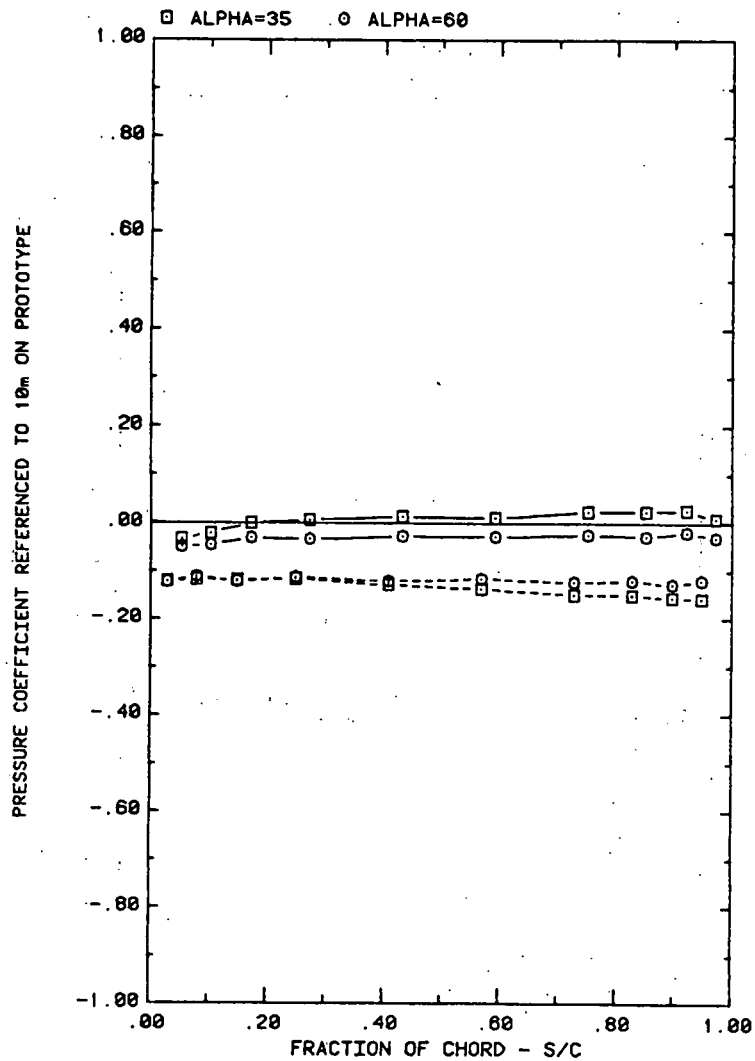

FRONT AND BACK PRESSURES ON ARRAY #4 IN BOUNDARY LAYER
 EFFECT OF ATTACK ANGLE FOR SPACING = 3C

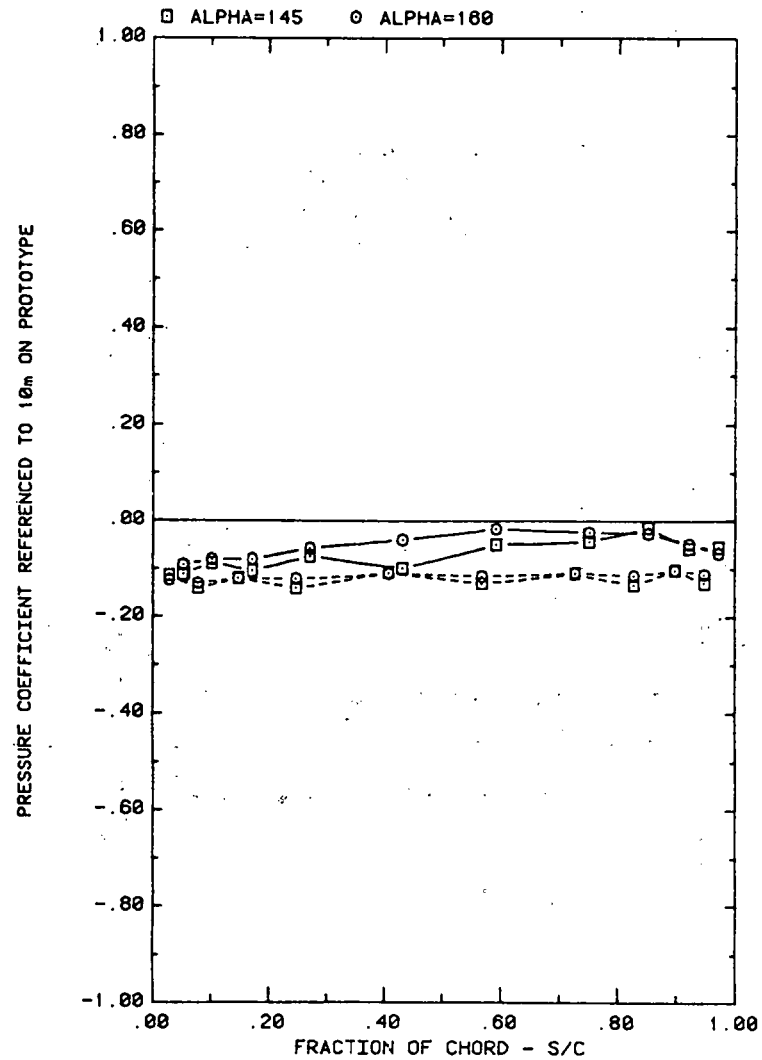

FRONT AND BACK PRESSURES ON ARRAY #5 IN BOUNDARY LAYER
 EFFECT OF ATTACK ANGLE FOR SPACING = 1.5C

Plot 2-2-1. (Continued)

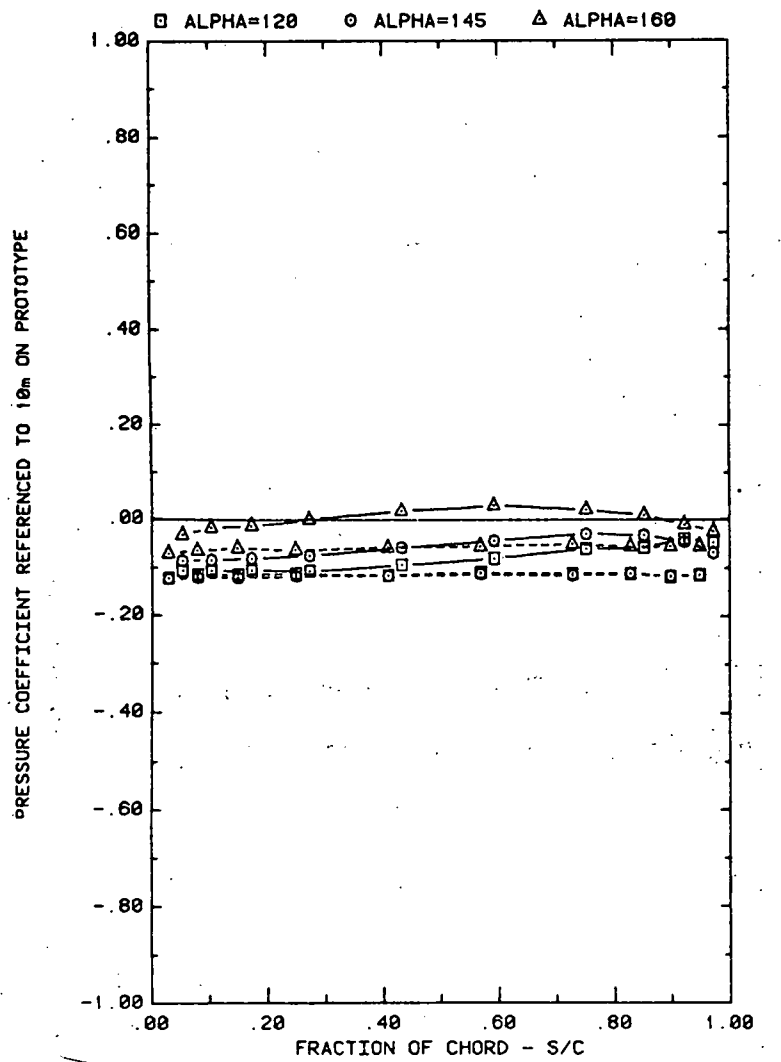

FRONT AND BACK PRESSURES ON ARRAY #5 IN BOUNDARY LAYER
EFFECT OF ATTACK ANGLE FOR SPACING = 2C

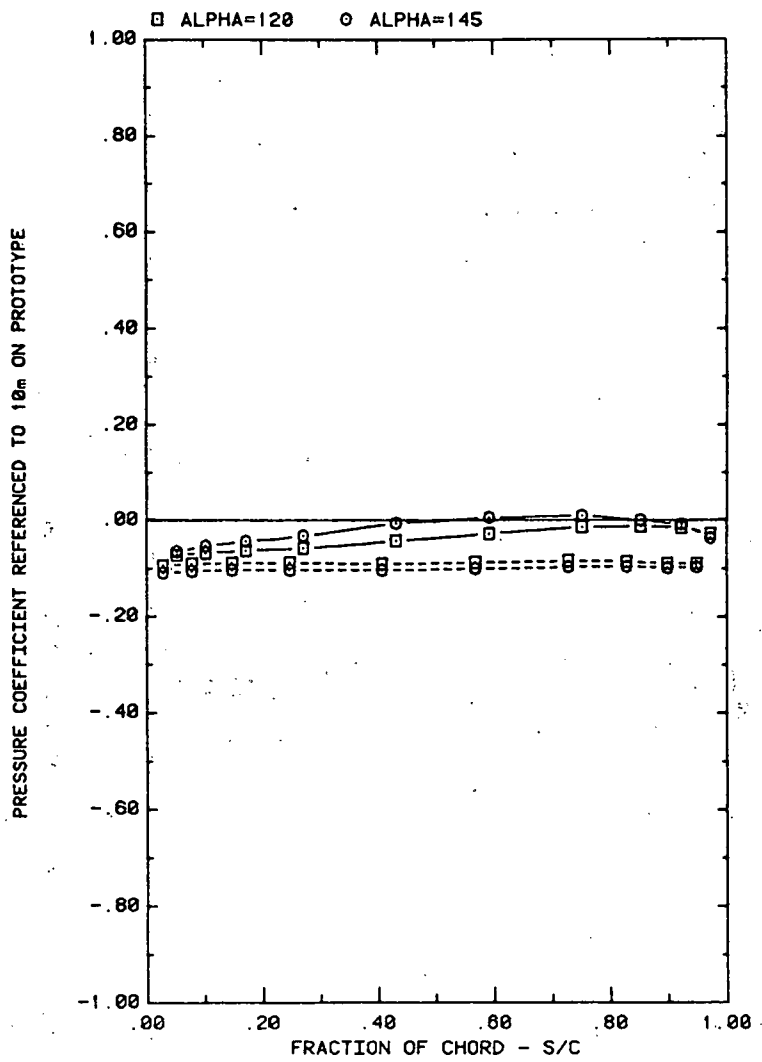

FRONT AND BACK PRESSURES ON ARRAY #4 IN BOUNDARY LAYER
EFFECT OF ATTACK ANGLE FOR SPACING = 3C

Plot 2-2-1. (Concluded)

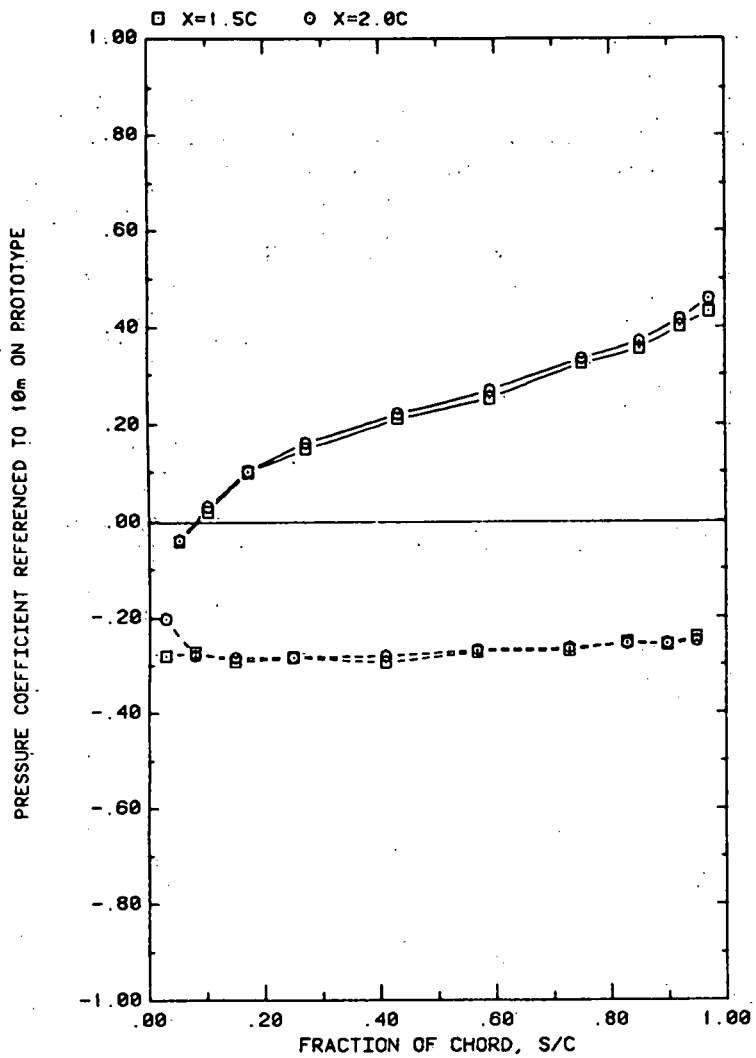

FRONT AND BACK PRESSURES ON ARRAY #1 IN BOUNDARY LAYER
EFFECT OF SEPARATION (X) ON ATTACK ANGLE 20° , $H/C = 0.25$

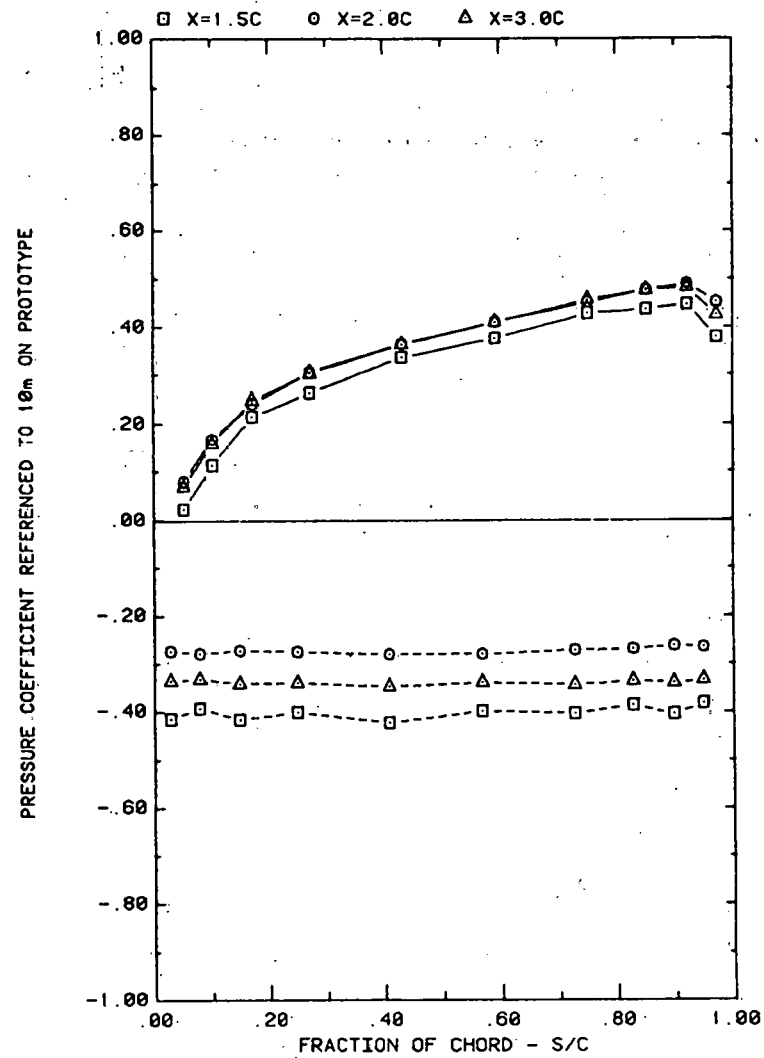

FRONT AND BACK PRESSURES ON ARRAY #1 IN BOUNDARY LAYER
EFFECT OF SEPARATION (X) ON ATTACK ANGLE 35° , $H/C = 0.25$

Plot 2-2-2. Multiple Arrays without Fence, Nonuniform Flow Study
Effect of Separation Distance

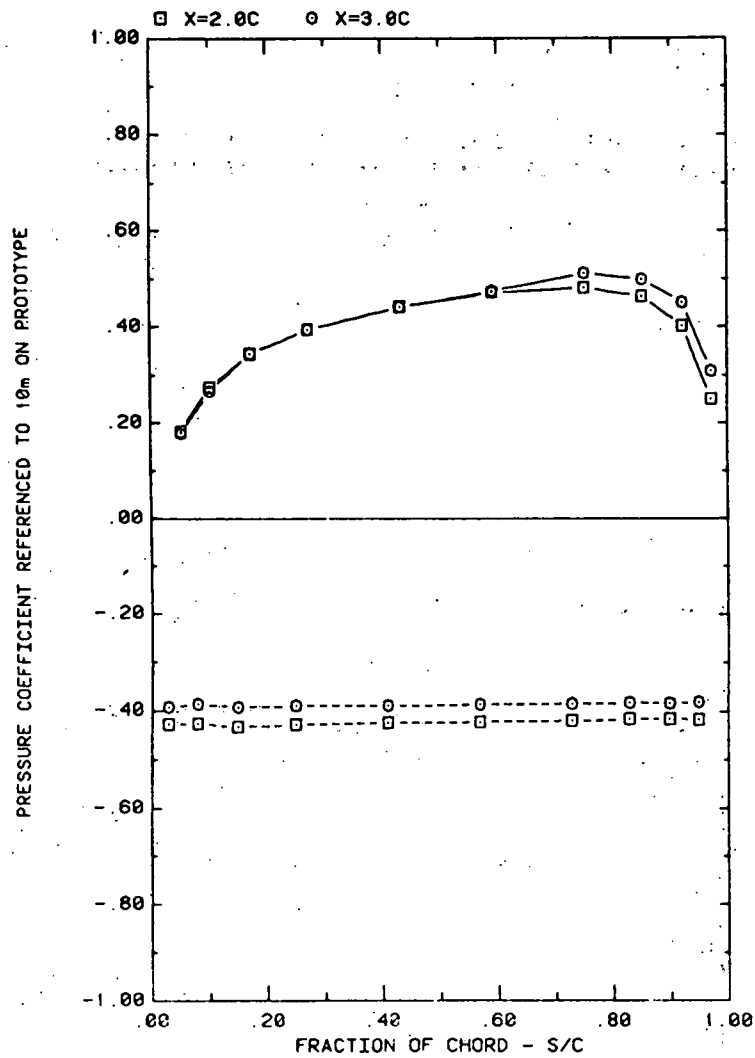

FRONT AND BACK PRESSURES ON ARRAY #1 IN BOUNDARY LAYER
EFFECT OF SEPARATION (X) ON ATTACK ANGLE 60, H/C = 0.25

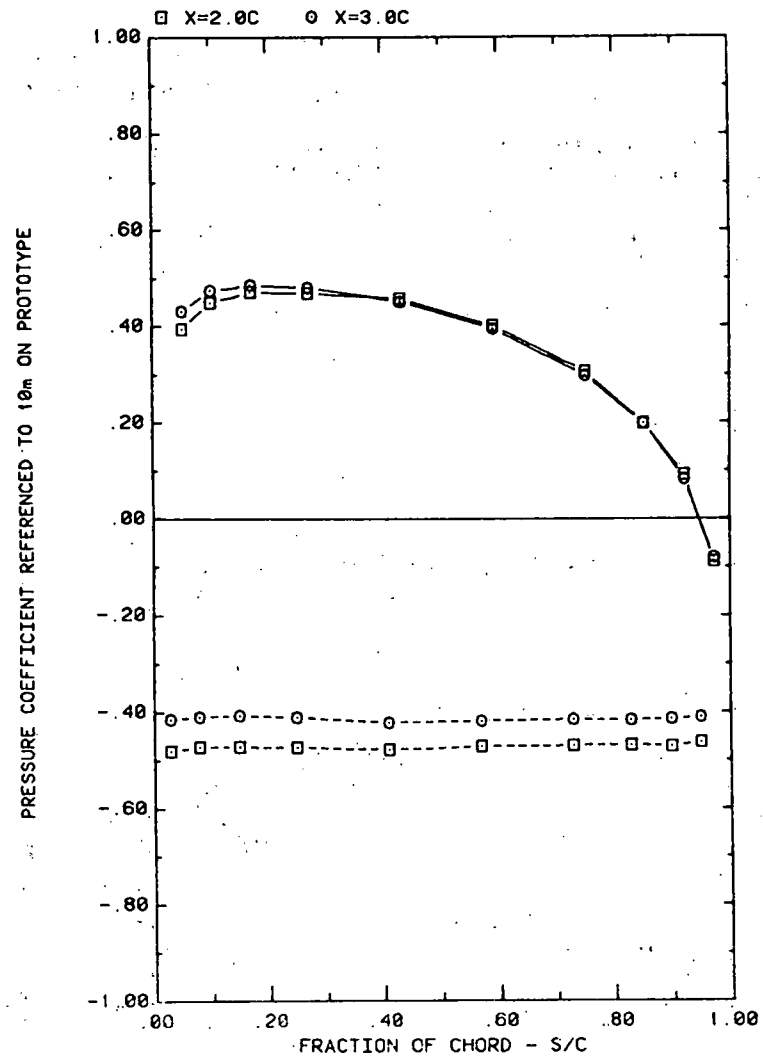

FRONT AND BACK PRESSURES ON ARRAY #1 IN BOUNDARY LAYER
EFFECT OF SEPARATION (X) ON ATTACK ANGLE 120, H/C = 0.25

Plot 2-2-2. (Continued)

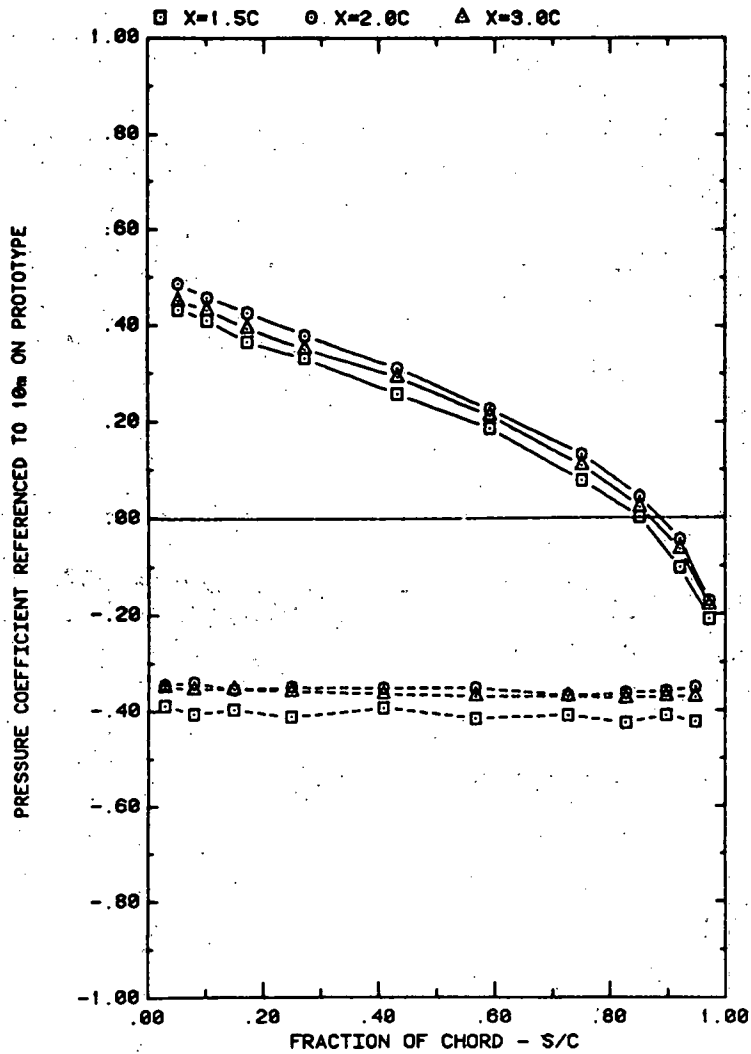

FRONT AND BACK PRESSURES ON ARRAY #1 IN BOUNDARY LAYER
 EFFECT OF SEPARATION (X) ON ATTACK ANGLE 145, H/C = 0.25

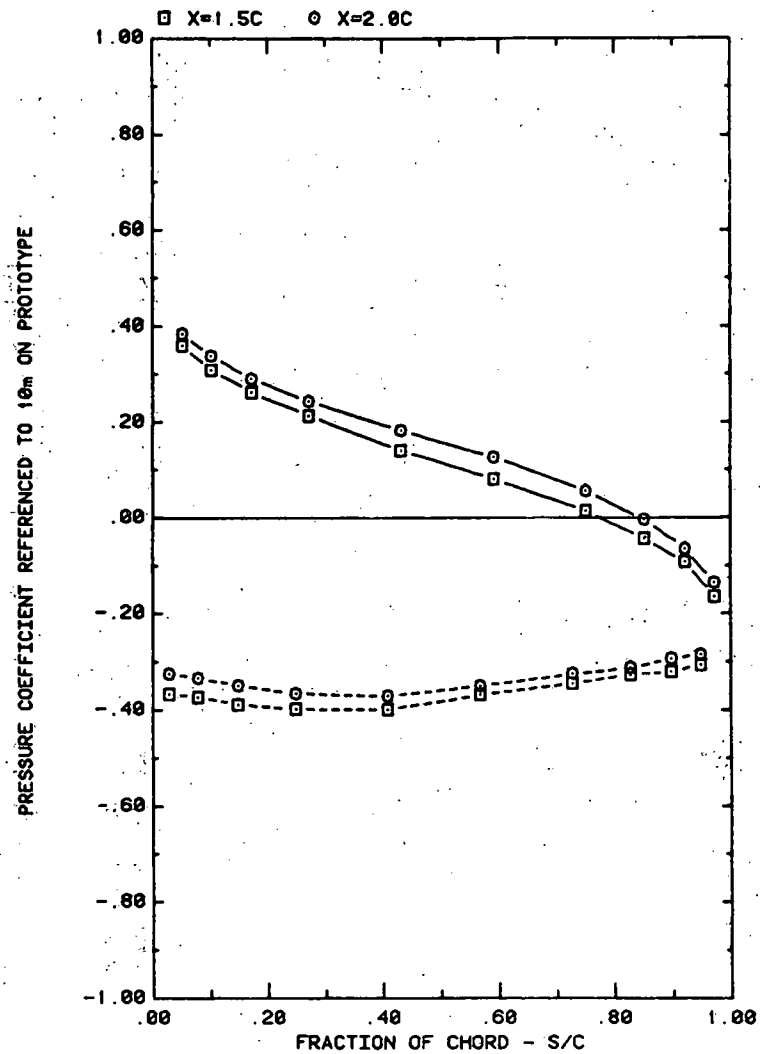

FRONT AND BACK PRESSURES ON ARRAY #1 IN BOUNDARY LAYER
 EFFECT OF SEPARATION (X) ON ATTACK ANGLE 160, H/C = 0.25

Plot 2-2-2. (Continued)

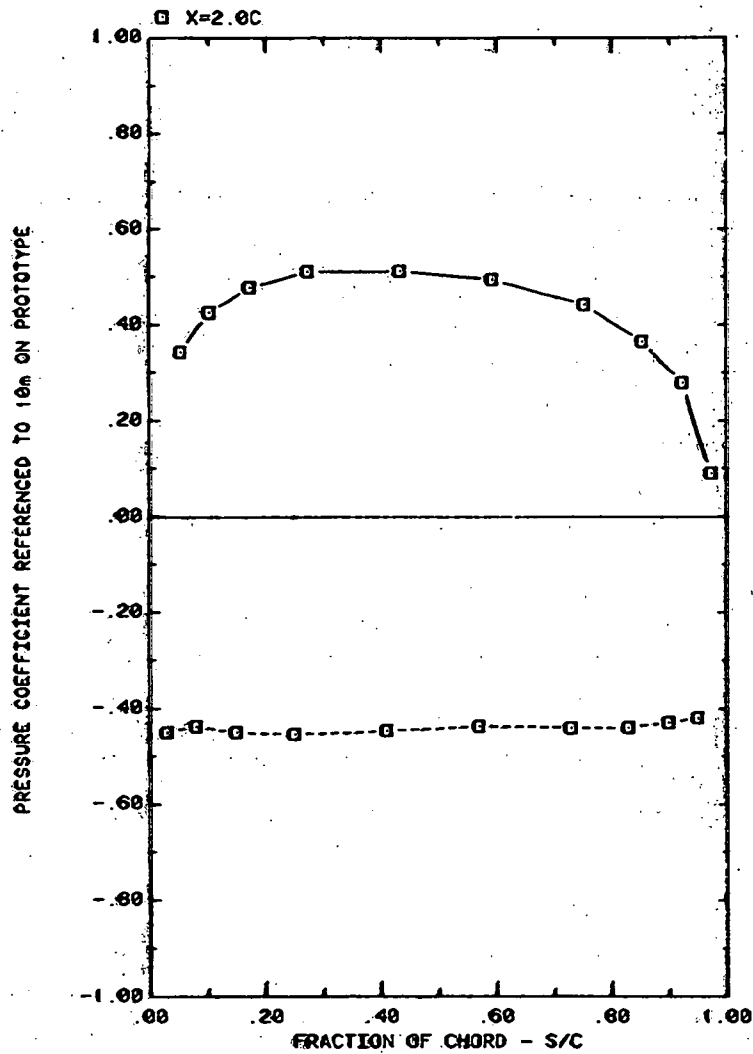

FRONT AND BACK PRESSURES ON ARRAY #1 IN BOUNDARY LAYER
EFFECT OF SEPARATION (X) ON ATTACK ANGLE 90, H/C = 0.25

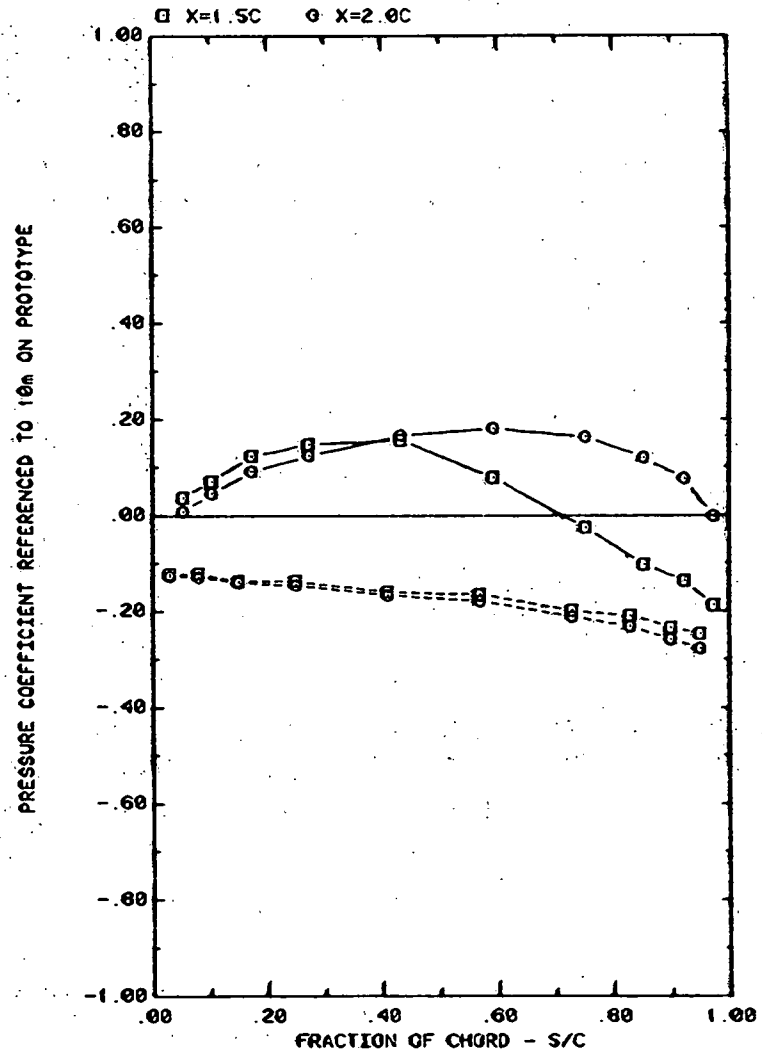

FRONT AND BACK PRESSURES ON ARRAY #2 IN BOUNDARY LAYER
EFFECT OF SEPARATION (X) ON ATTACK ANGLE 20, H/C = 0.25

Plot 2-2-2. (Continued)

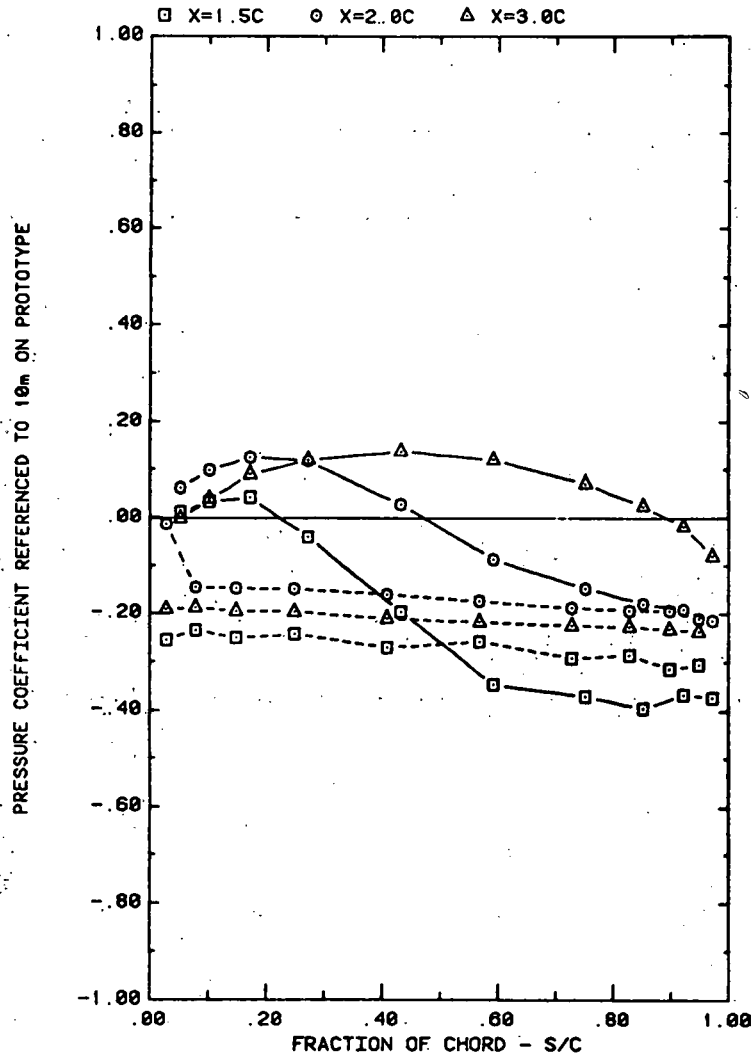

FRONT AND BACK PRESSURES ON ARRAY #2 IN BOUNDARY LAYER
EFFECT OF SEPARATION (X) ON ATTACK ANGLE 35, H/C = 0.25

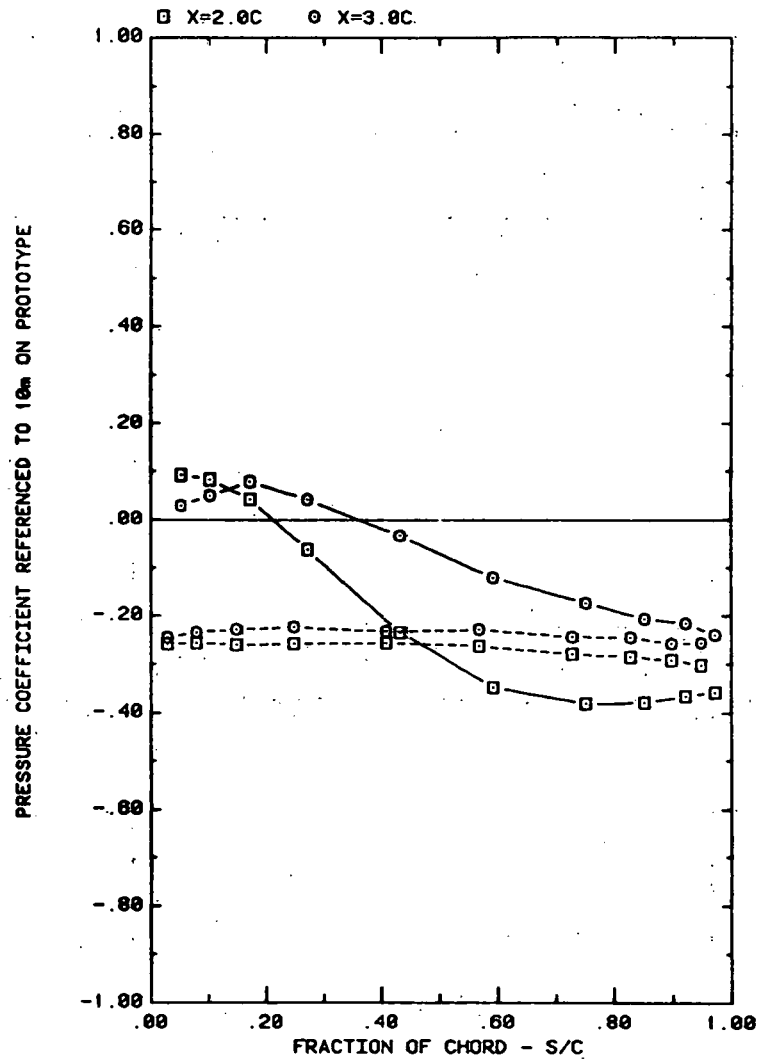

FRONT AND BACK PRESSURES ON ARRAY #2 IN BOUNDARY LAYER
EFFECT OF SEPARATION (X) ON ATTACK ANGLE 60, H/C = 0.25

Plot 2-2-2. (Continued)

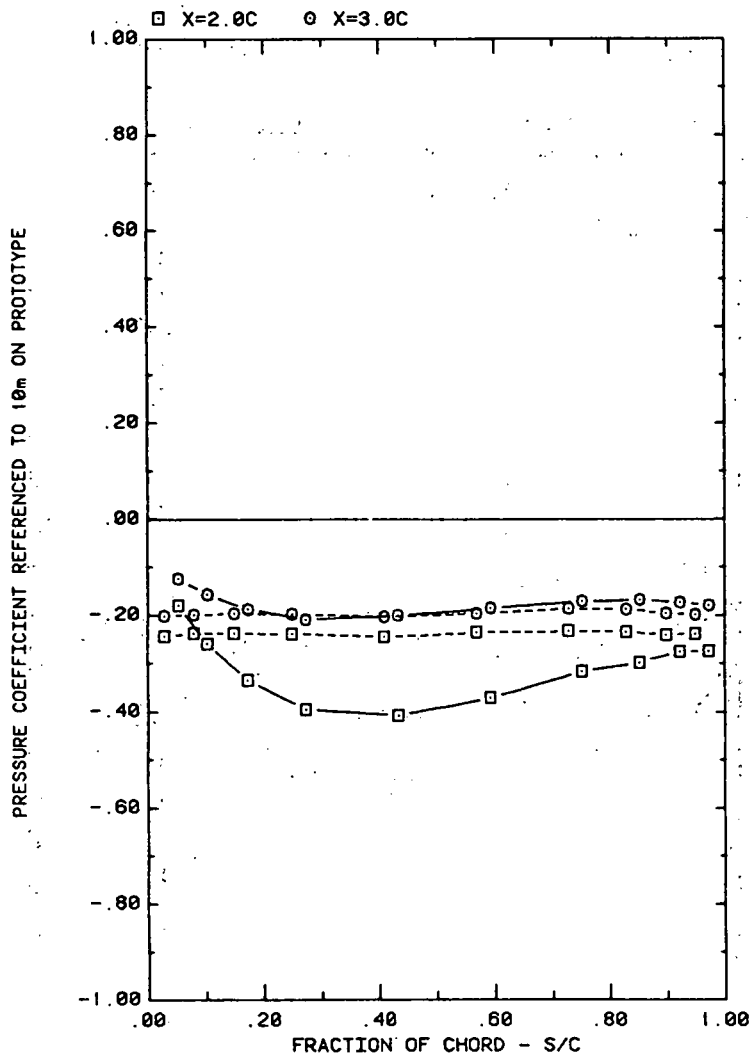

FRONT AND BACK PRESSURES ON ARRAY #2 IN BOUNDARY LAYER
EFFECT OF SEPARATION (X) ON ATTACK ANGLE 120, H/C = 0.25

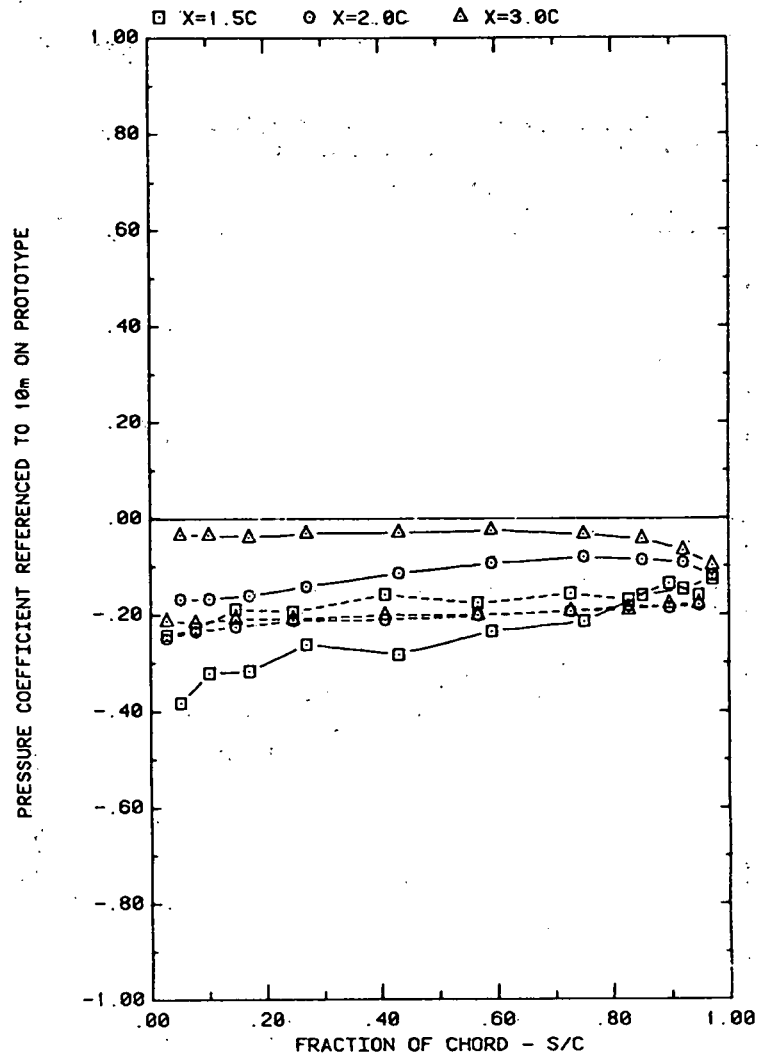

FRONT AND BACK PRESSURES ON ARRAY #2 IN BOUNDARY LAYER
EFFECT OF SEPARATION (X) ON ATTACK ANGLE 145, H/C = 0.25

Plot 2-2-2. (Continued)

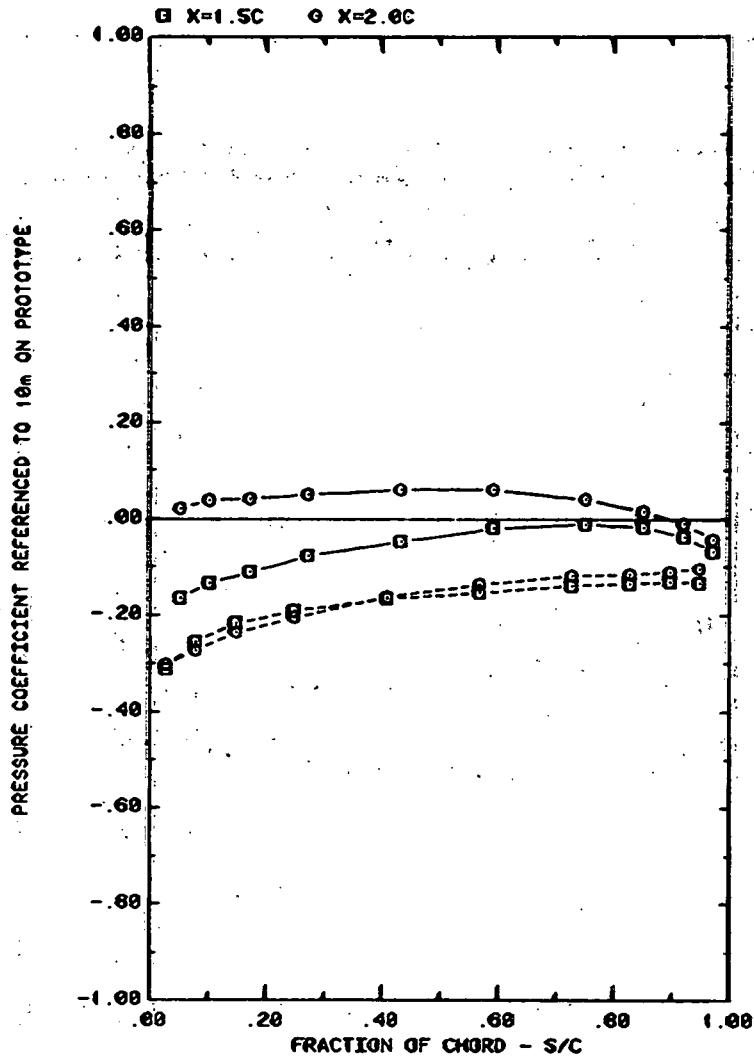

FRONT AND BACK PRESSURES ON ARRAY #2 IN BOUNDARY LAYER
 EFFECT OF SEPARATION (X) ON ATTACK ANGLE 160, H/C = 0.25

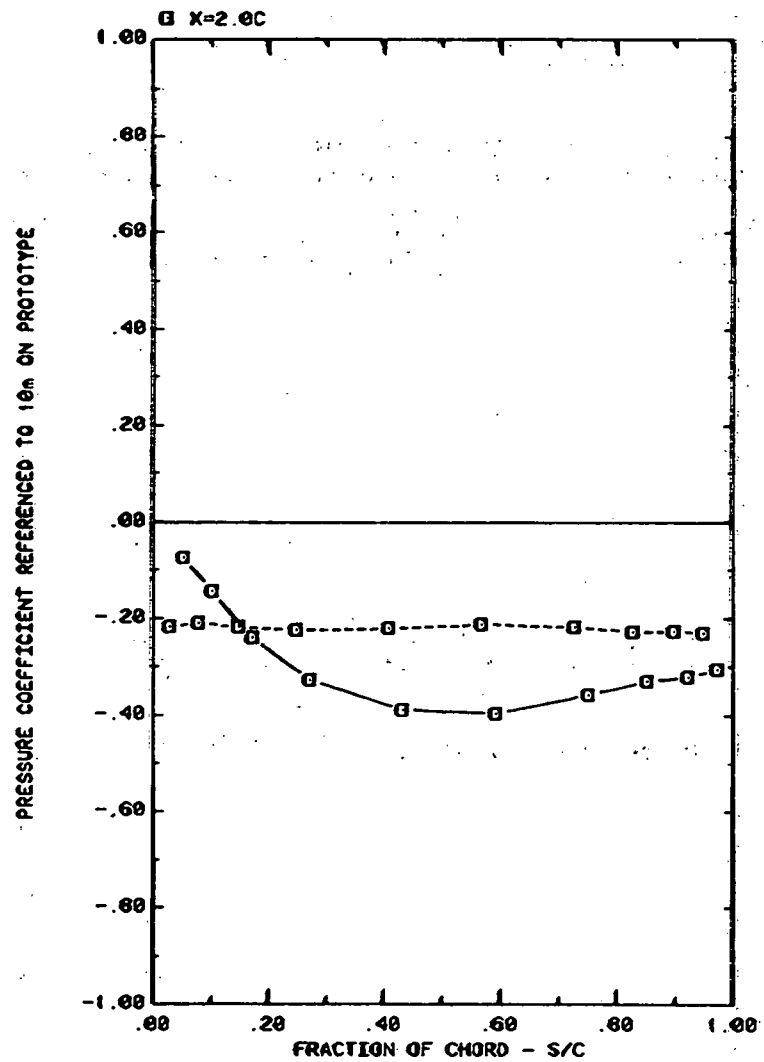

FRONT AND BACK PRESSURES ON ARRAY #2 IN BOUNDARY LAYER
 EFFECT OF SEPARATION (X) ON ATTACK ANGLE 90, H/C = 0.25

Plot 2-2-2. (Continued)

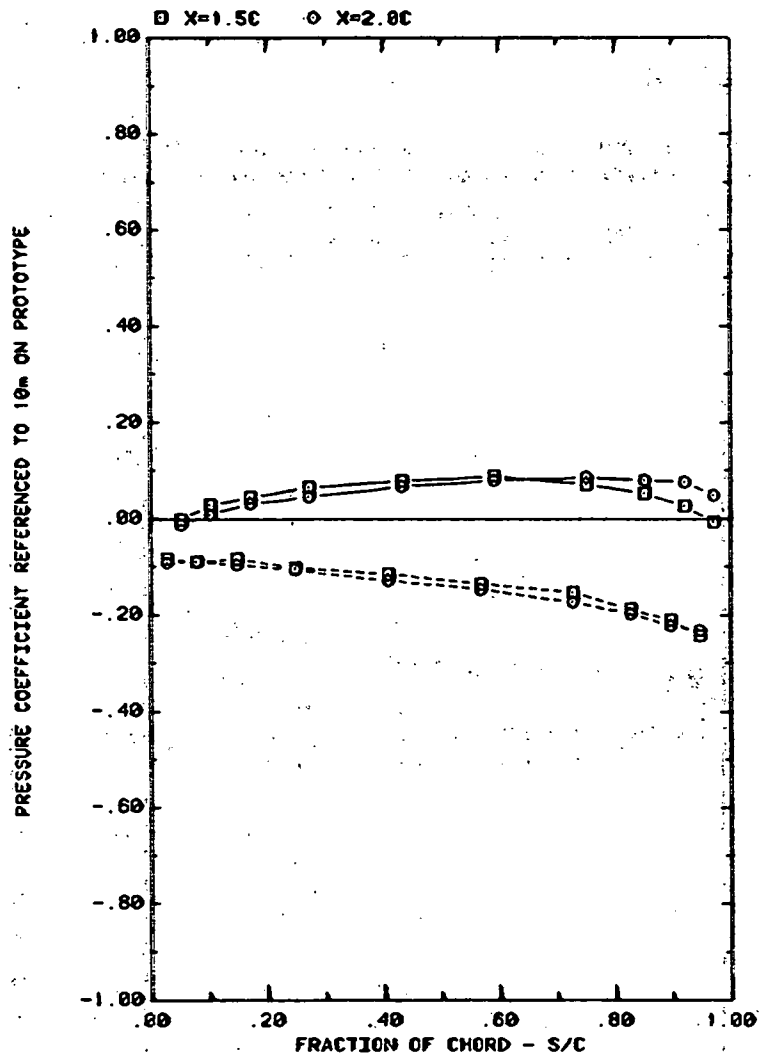

FRONT AND BACK PRESSURES ON ARRAY #5 IN BOUNDARY LAYER
EFFECT OF SEPARATION (X) ON ATTACK ANGLE 20; H/C = 0.25

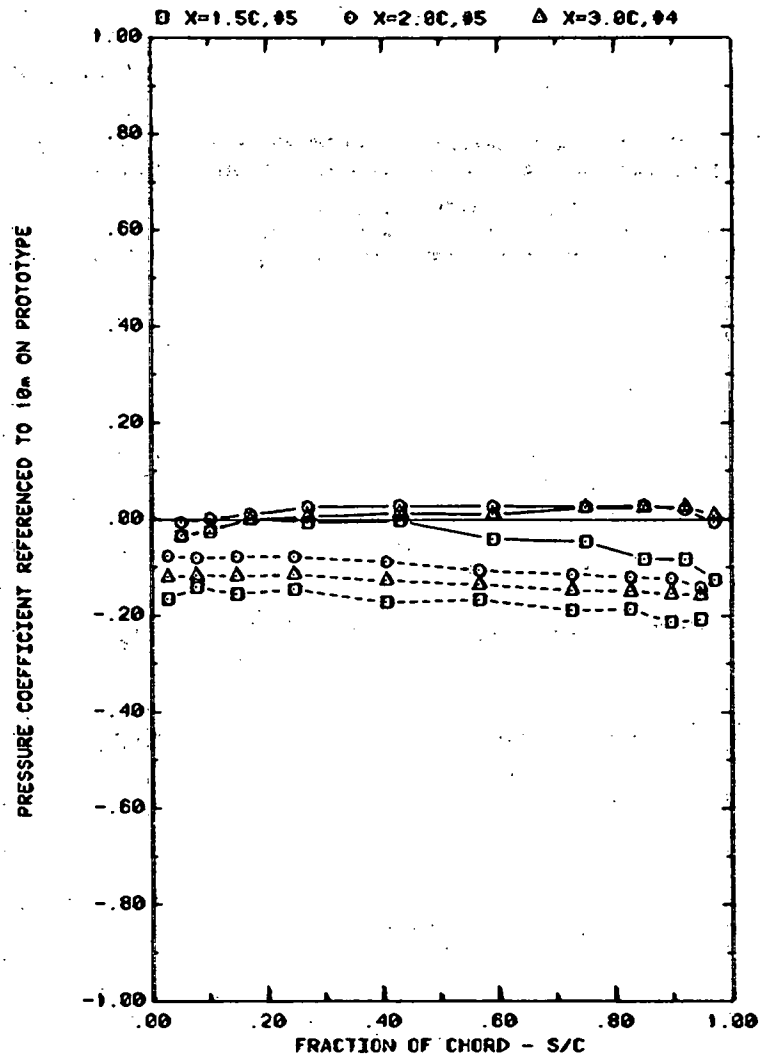

FRONT AND BACK PRESSURES ON ARRAY #4 OR #5 IN BOUNDARY LAYER
EFFECT OF SEPARATION (X) ON ATTACK ANGLE 35; H/C = 0.25

Plot 2-2-2. (Continued)

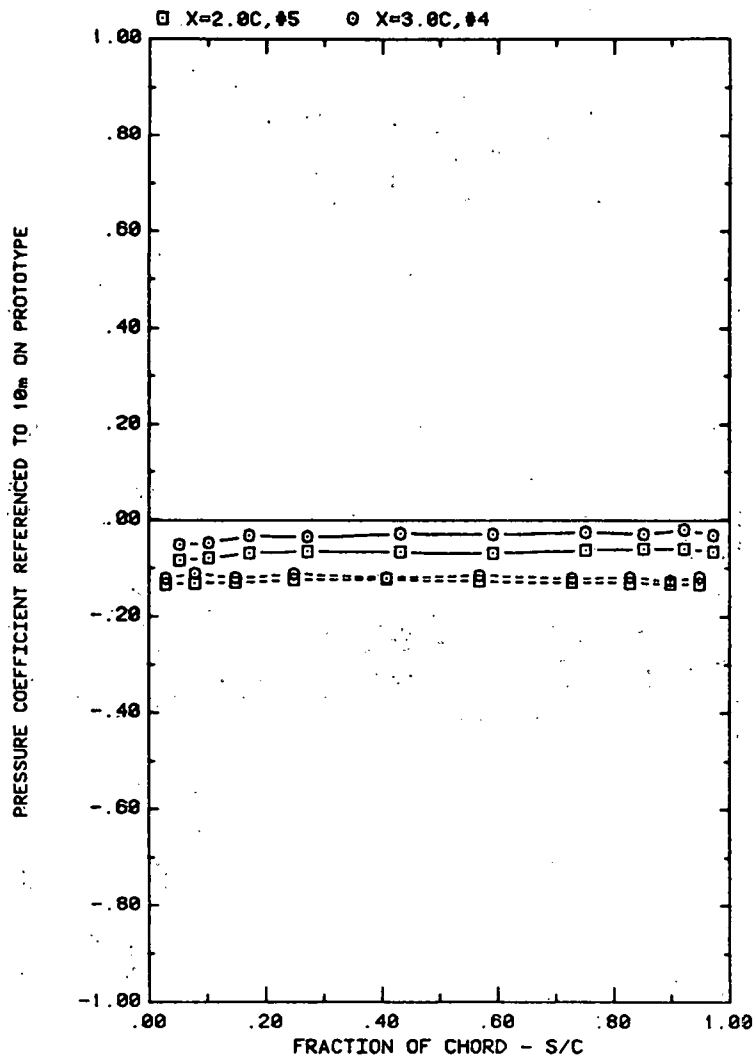

FRONT AND BACK PRESSURES ON ARRAY #4 OR #5 IN BOUNDARY LAYER
EFFECT OF SEPARATION (X) ON ATTACK ANGLE 60, H/C = 0.25

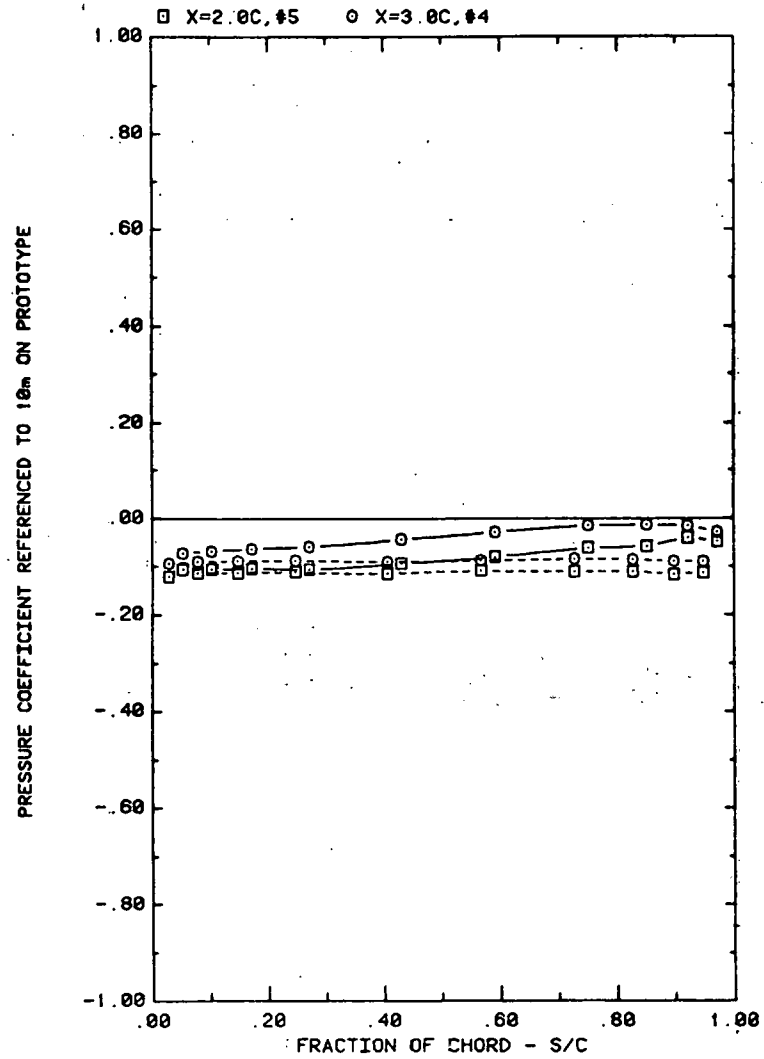

FRONT AND BACK PRESSURES ON ARRAY #4 OR #5 IN BOUNDARY LAYER
EFFECT OF SEPARATION (X) ON ATTACK ANGLE 120, H/C = 0.25

Plot 2-2-2. (Continued)

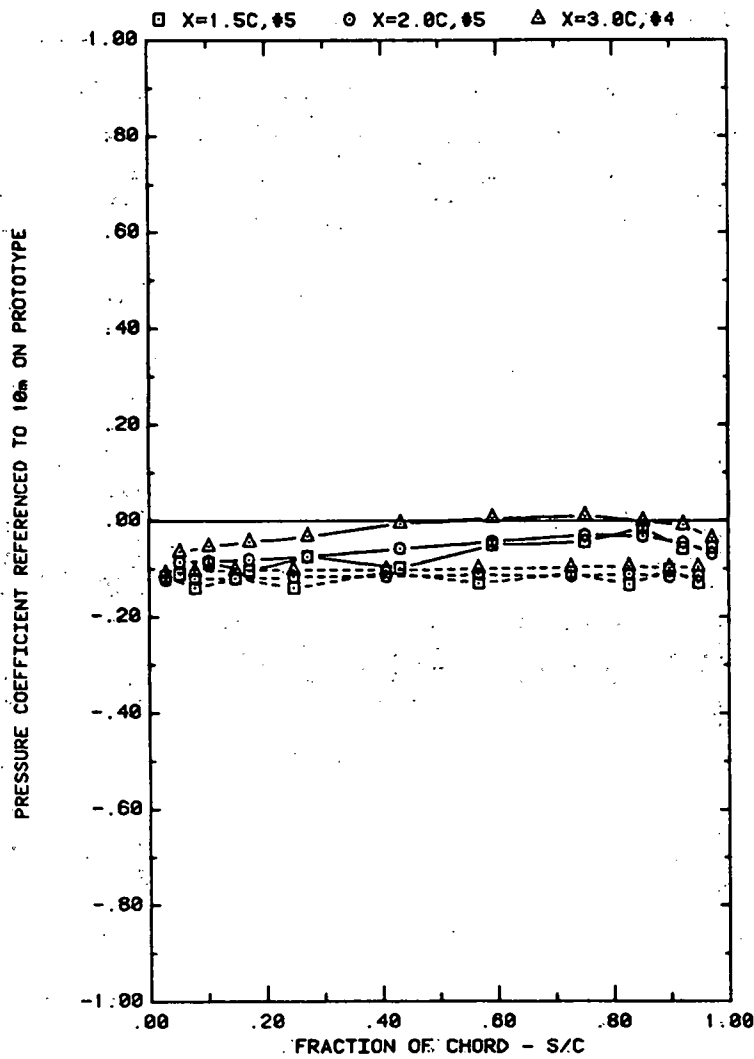

FRONT AND BACK PRESSURES ON ARRAY #4 OR #5 IN BOUNDARY LAYER
 EFFECT OF SEPARATION (X) ON ATTACK ANGLE 145, H/C = 0.25

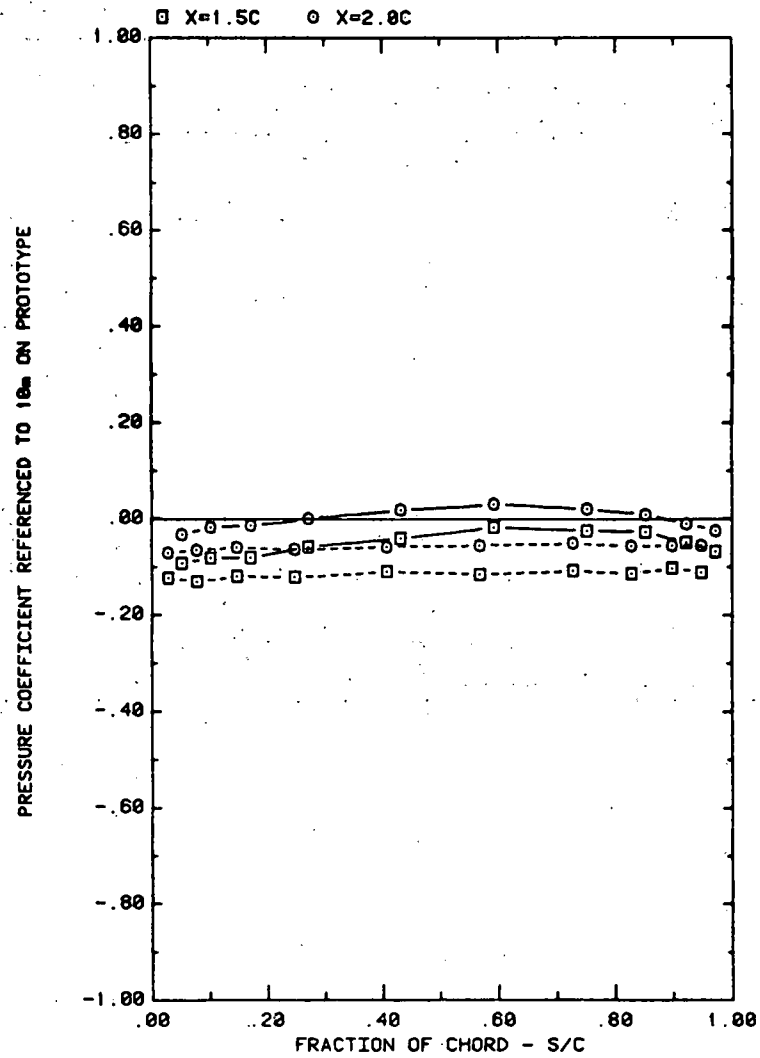

FRONT AND BACK PRESSURES ON ARRAY #5 IN BOUNDARY LAYER
 EFFECT OF SEPARATION (X) ON ATTACK ANGLE 160, H/C = 0.25

Plot 2-2-2. (Continued)

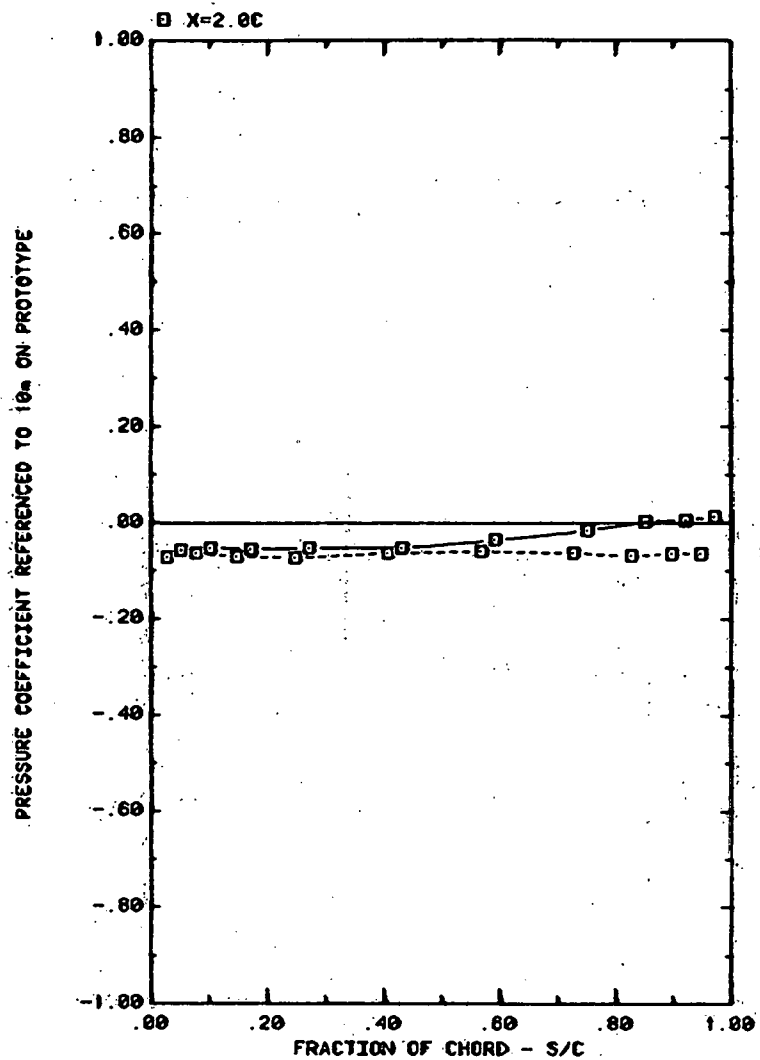

FRONT AND BACK PRESSURES ON ARRAY #5 IN BOUNDARY LAYER
EFFECT OF SEPARATION (X) ON ATTACK ANGLE 90, H/C = 0.25

Plot 2-2-2. (Concluded)

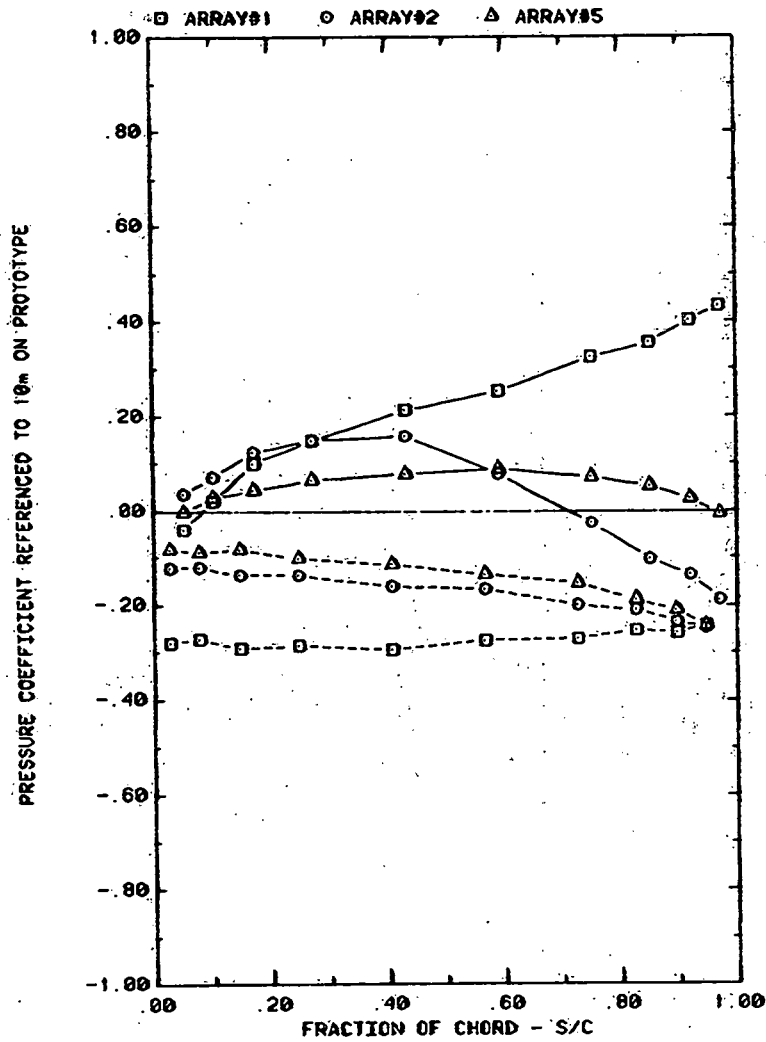

FRONT AND BACK PRESSURES ON ARRAYS IN BOUNDARY LAYER, $x = 1.5c$
EFFECT OF ARRAY CONFIGURATION ON ATTACK ANGLE 20° , $h/c = 0.25$

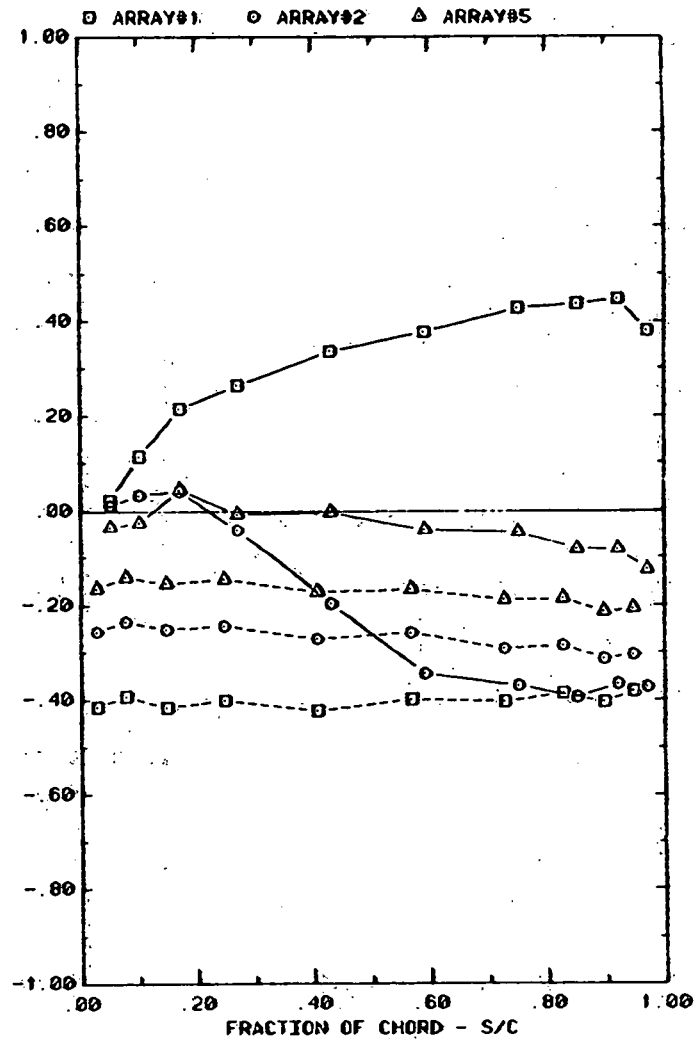

FRONT AND BACK PRESSURES ON ARRAYS IN BOUNDARY LAYER, $x = 1.5c$
EFFECT OF ARRAY CONFIGURATION ON ATTACK ANGLE 35° , $h/c = 0.25$

Plot 2-2-3. Multiple Arrays without Fence, Nonuniform Flow Study
Effect of Array Position

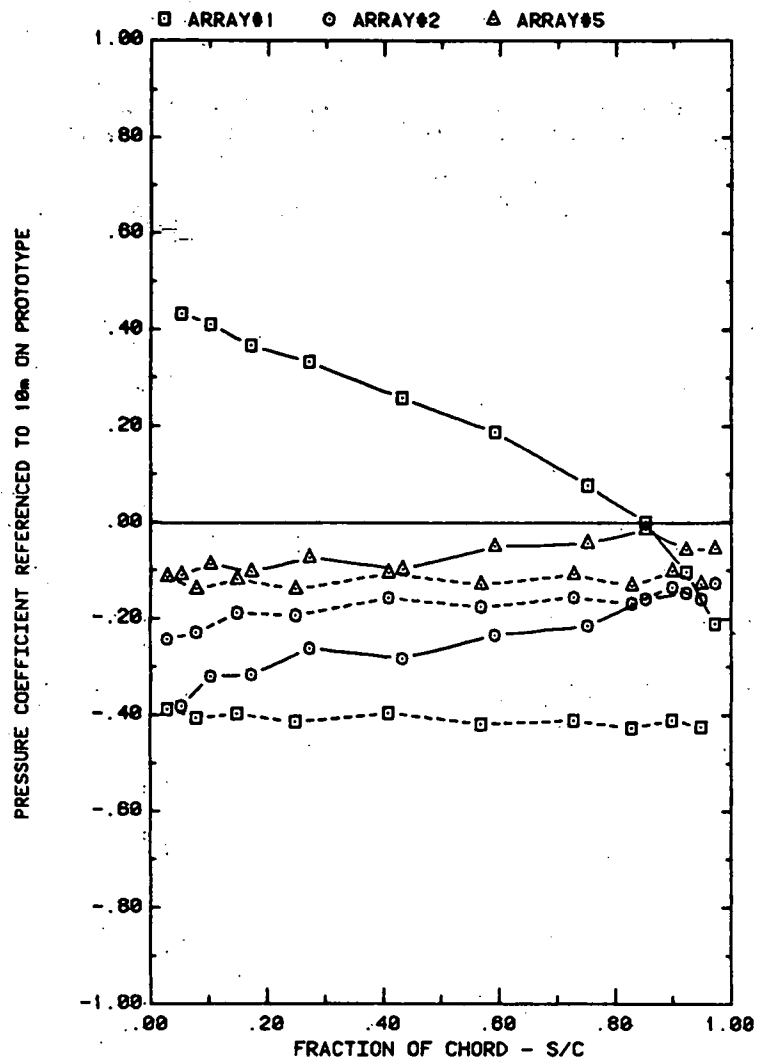

FRONT AND BACK PRESSURES ON ARRAYS IN BOUNDARY LAYER, $X = 1.5C$
EFFECT OF ARRAY CONFIGURATION ON ATTACK ANGLE 145° , $H/C = 0.25$

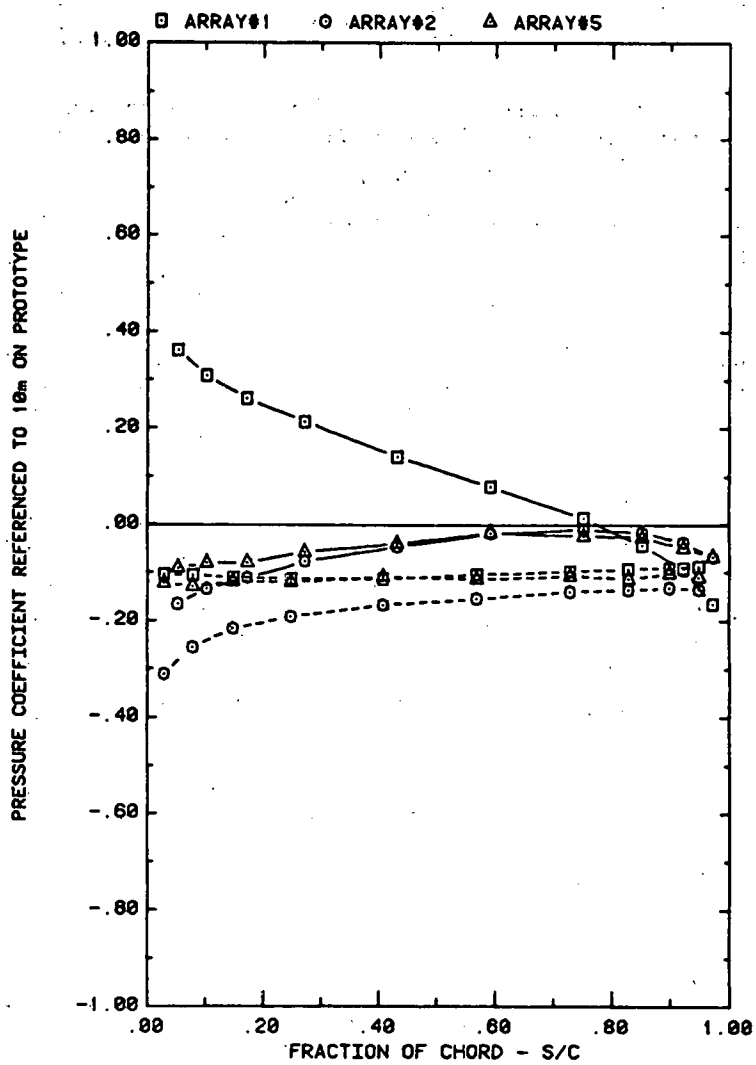

FRONT AND BACK PRESSURES ON ARRAYS IN BOUNDARY LAYER, $X = 1.5C$
EFFECT OF ARRAY CONFIGURATION ON ATTACK ANGLE 160° , $H/C = 0.25$

Plot 2-2-3. (Continued)

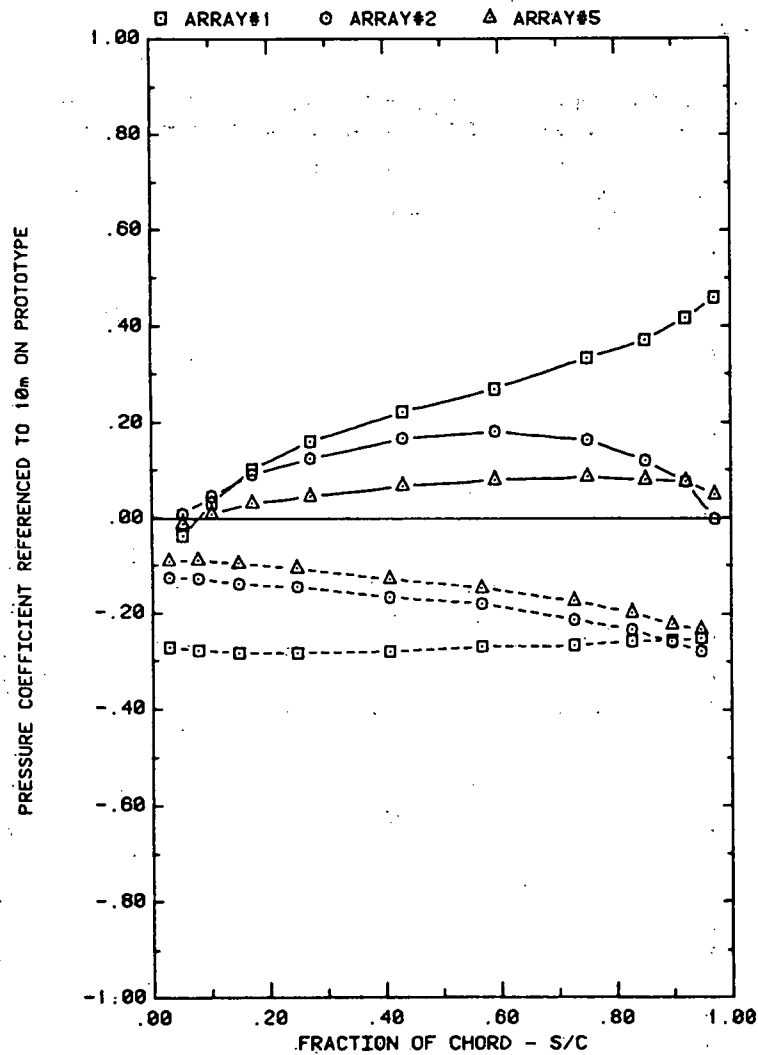

FRONT AND BACK PRESSURES ON ARRAYS IN BOUNDARY LAYER, $X = 2.0C$
EFFECT OF ARRAY CONFIGURATION ON ATTACK ANGLE 20° , $H/C = 0.25$

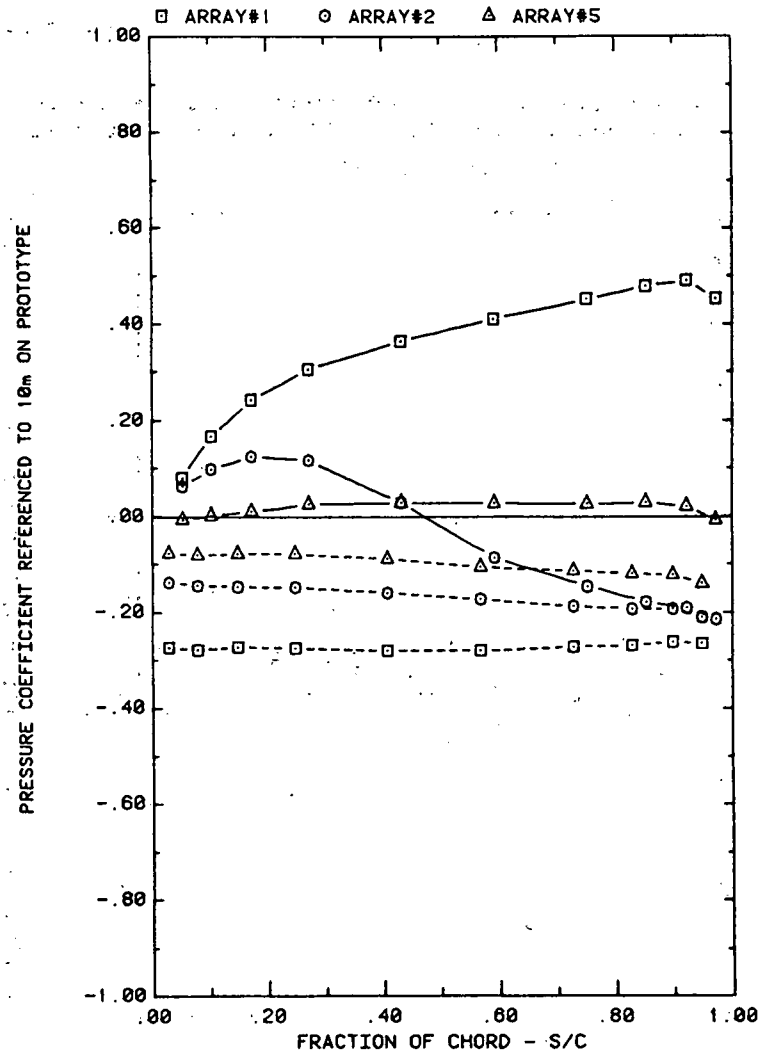

FRONT AND BACK PRESSURES ON ARRAYS IN BOUNDARY LAYER, $X = 2.0C$
EFFECT OF ARRAY CONFIGURATION ON ATTACK ANGLE 35° , $H/C = 0.25$

Plot 2-2-3. (Continued)

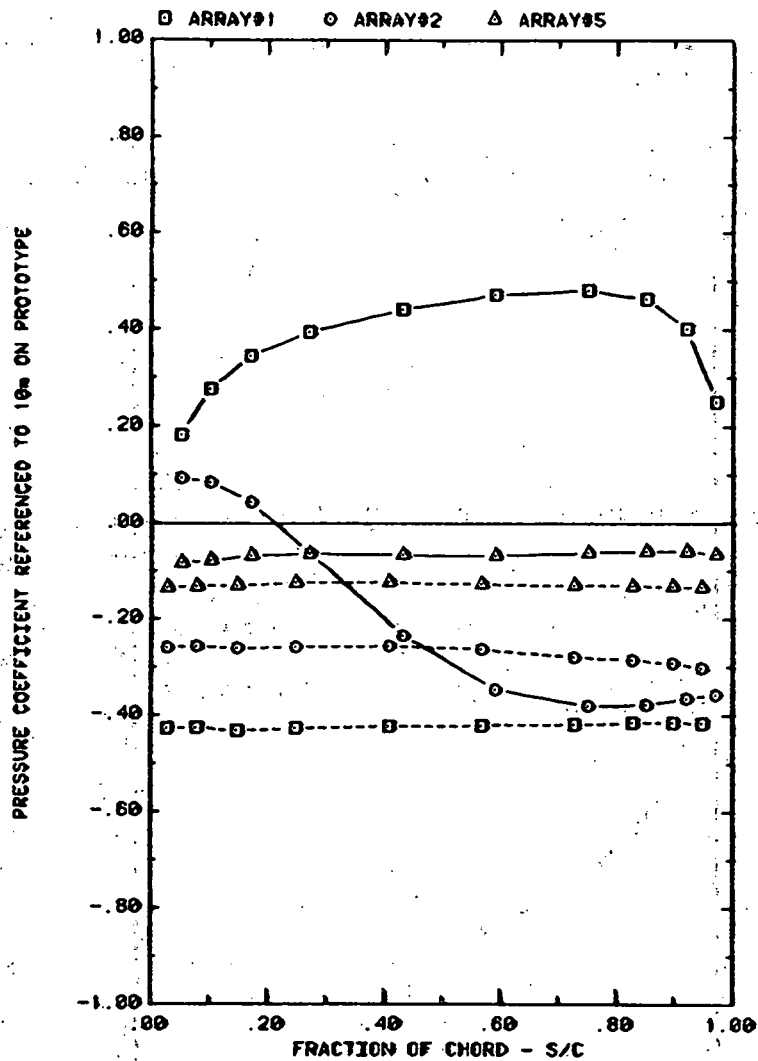

FRONT AND BACK PRESSURES ON ARRAYS IN BOUNDARY LAYER, $\alpha = 60^\circ$
EFFECT OF ARRAY CONFIGURATION ON ATTACK ANGLE 60° , $H/C = 0.25$

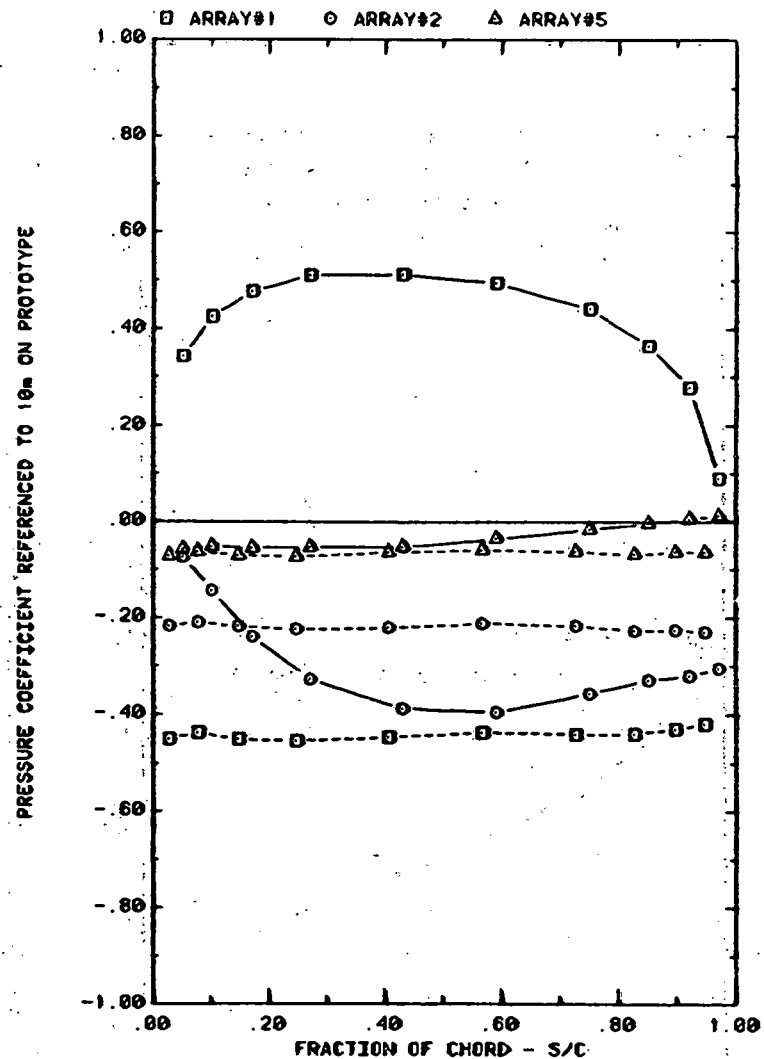

FRONT AND BACK PRESSURES ON ARRAYS IN BOUNDARY LAYER, $\alpha = 90^\circ$
EFFECT OF ARRAY CONFIGURATION ON ATTACK ANGLE 90° , $H/C = 0.25$

Plot 2-2-3. (Continued)

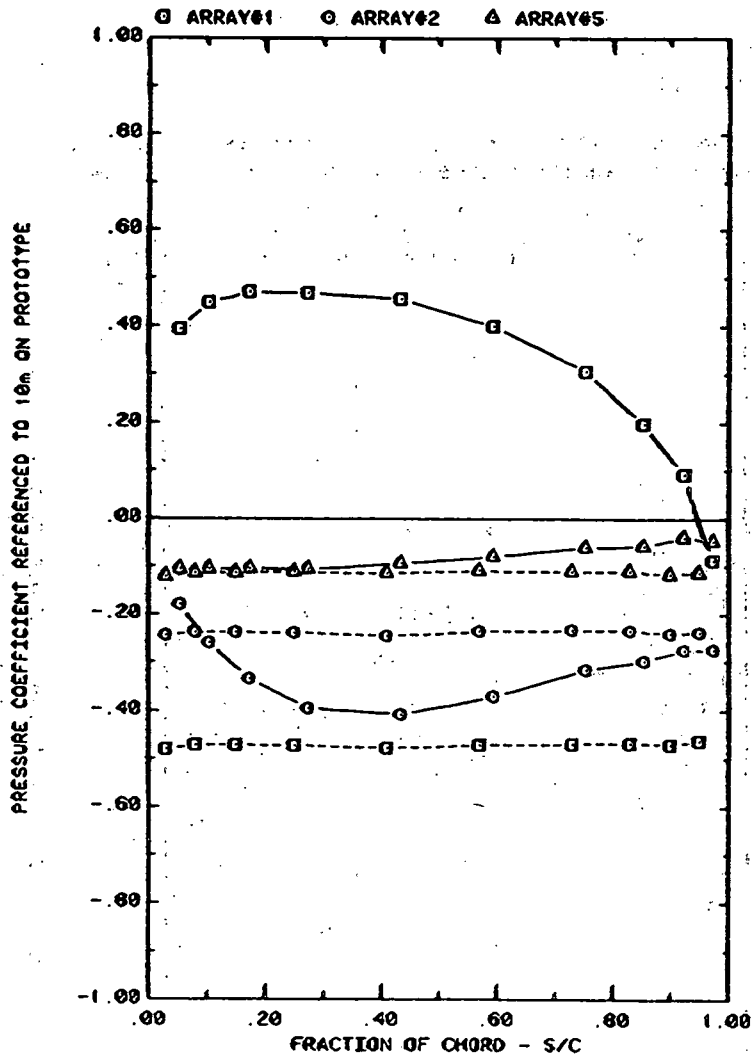

FRONT AND BACK PRESSURES ON ARRAYS IN BOUNDARY LAYER, $\alpha = 120^\circ$
EFFECT OF ARRAY CONFIGURATION ON ATTACK ANGLE 120, $h/c = 0.25$

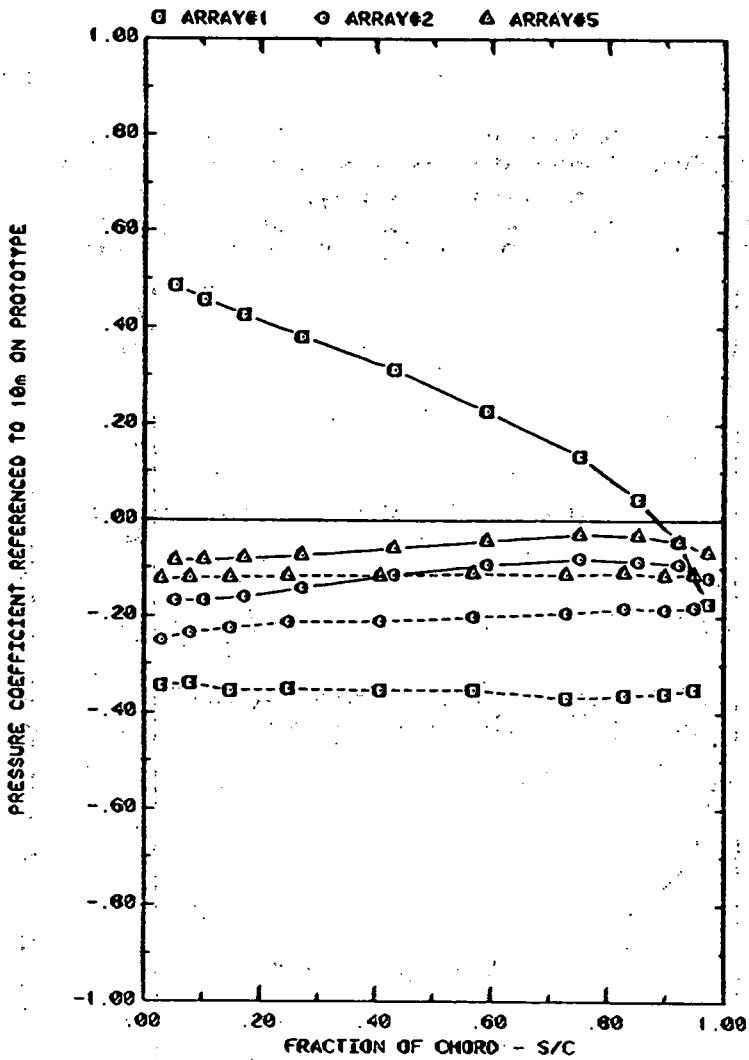

FRONT AND BACK PRESSURES ON ARRAYS IN BOUNDARY LAYER, $\alpha = 145^\circ$
EFFECT OF ARRAY CONFIGURATION ON ATTACK ANGLE 145, $h/c = 0.25$

Plot 2-2-3. (Continued)

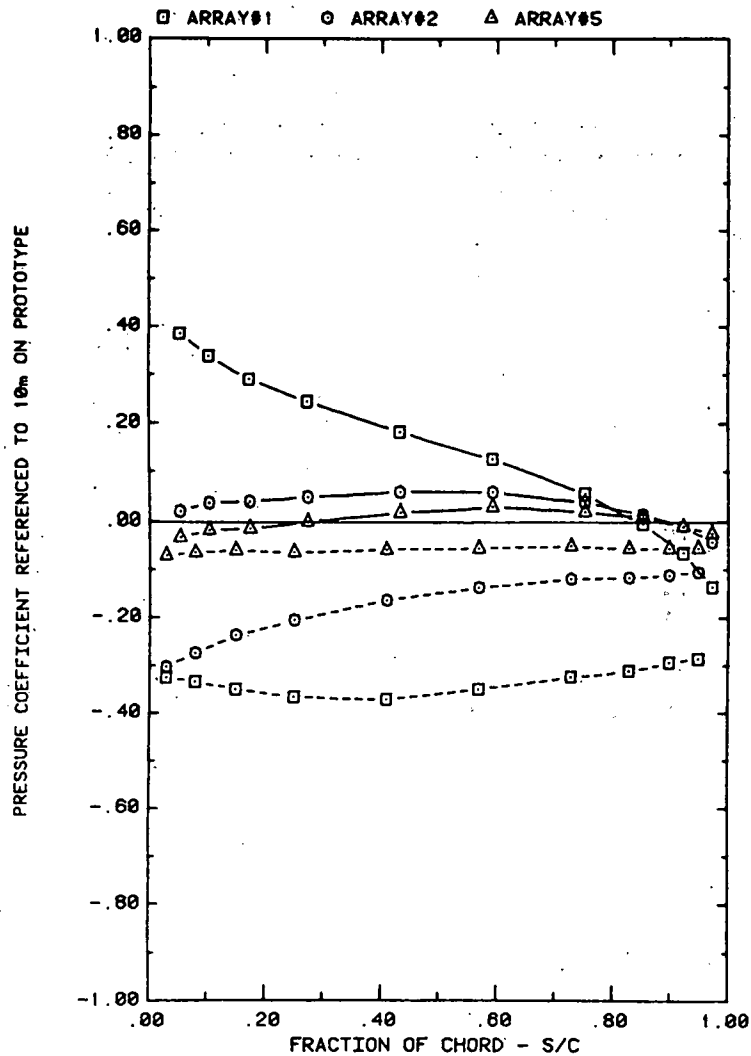

FRONT AND BACK PRESSURES ON ARRAYS IN BOUNDARY LAYER, $X = 2.0c$
EFFECT OF ARRAY CONFIGURATION ON ATTACK ANGLE 160° , $H/C = 0.25$

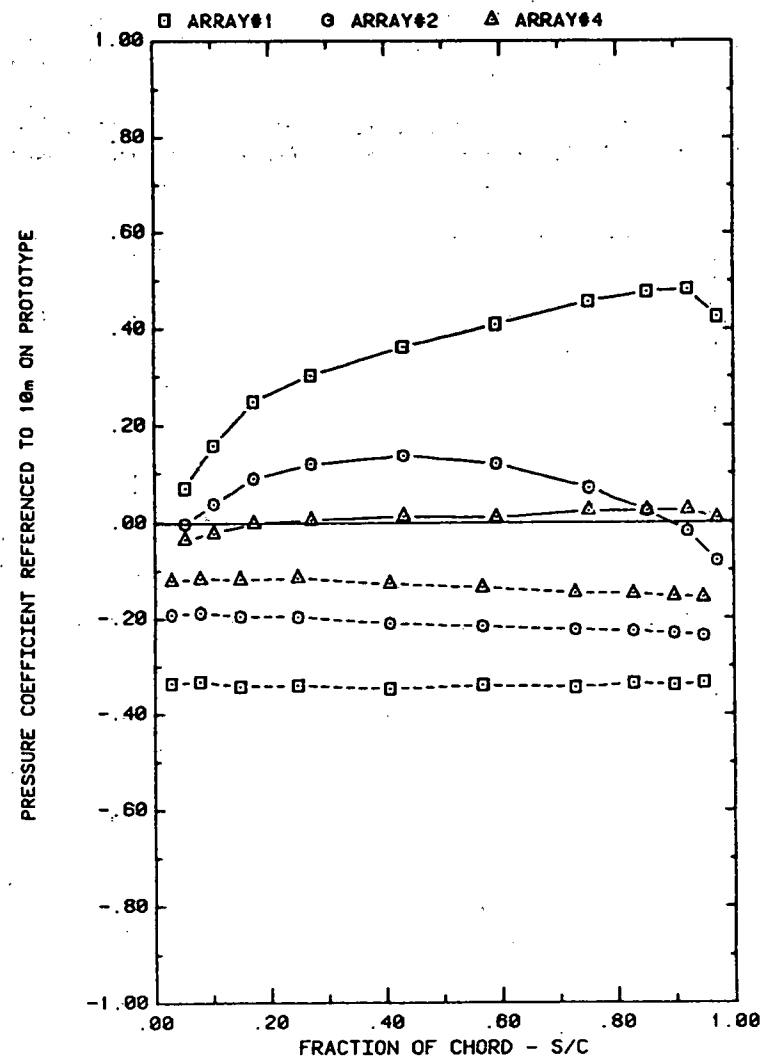

FRONT AND BACK PRESSURES ON ARRAYS IN BOUNDARY LAYER, $X = 3.0c$
EFFECT OF ARRAY CONFIGURATION ON ATTACK ANGLE 35° , $H/C = 0.25$

Plot 2-2-3. (Continued)

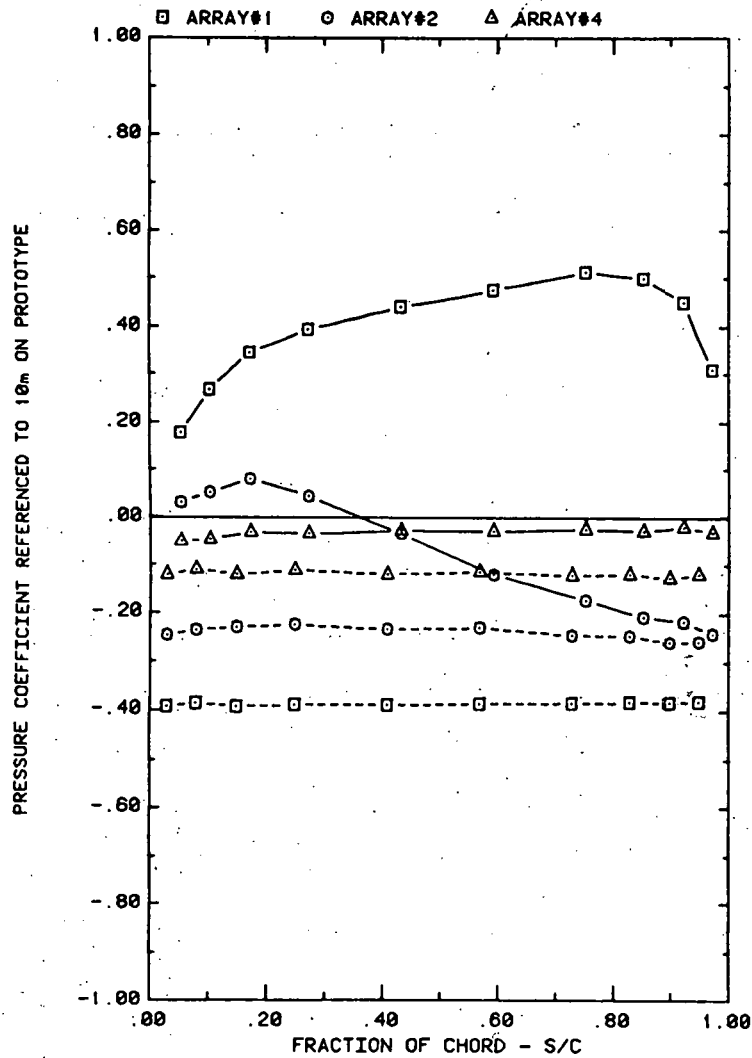

FRONT AND BACK PRESSURES ON ARRAYS IN BOUNDARY LAYER, $X = 3.0C$
EFFECT OF ARRAY CONFIGURATION ON ATTACK ANGLE 60° , $H/C = 0.25$

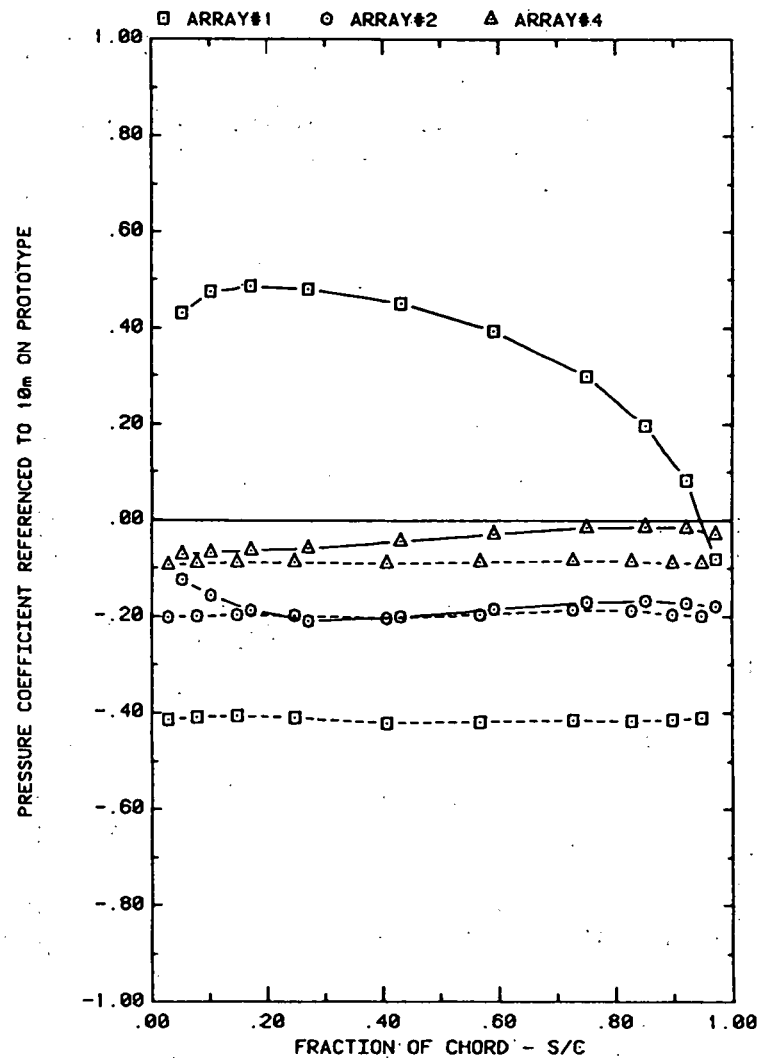

FRONT AND BACK PRESSURES ON ARRAYS IN BOUNDARY LAYER, $X = 3.0C$
EFFECT OF ARRAY CONFIGURATION ON ATTACK ANGLE 120° , $H/C = 0.25$

Plot 2-2-3. (Continued)

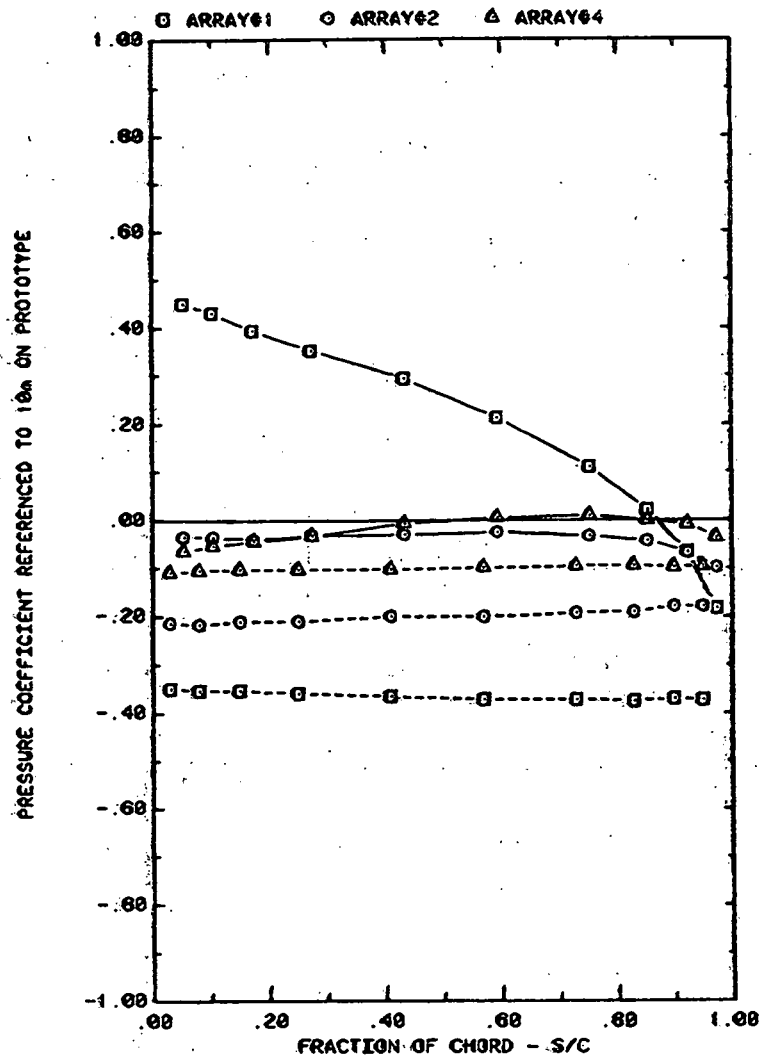

FRONT AND BACK PRESSURES ON ARRAYS IN BOUNDARY LAYER, $\alpha = 3.00$
 EFFECT OF ARRAY CONFIGURATION ON ATTACK ANGLE 145° , $H/C = 0.25$

Plot 2-2-3. (Concluded)

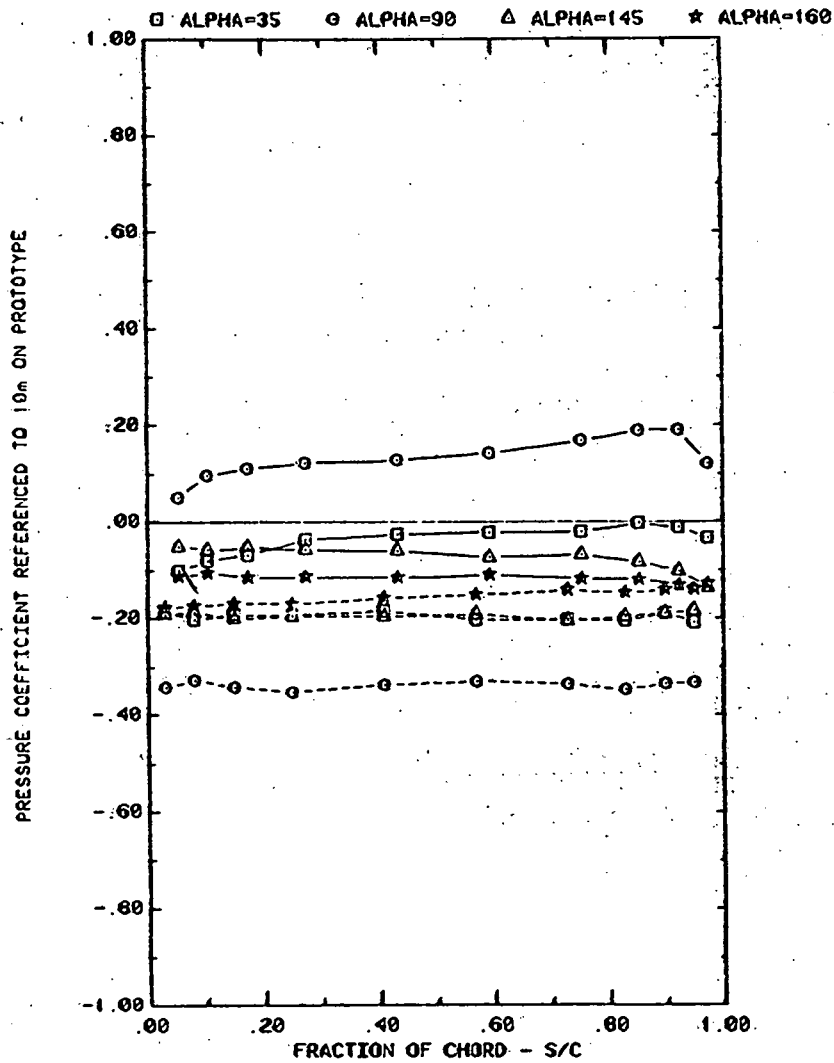

FRONT AND BACK PRESSURES ON ARRAY #1 WITH SEPARATION = $2C$
EFFECT OF ATTACK ANGLE WITH $H=3^\circ$, $P=30\%$, AND $D=5^\circ$

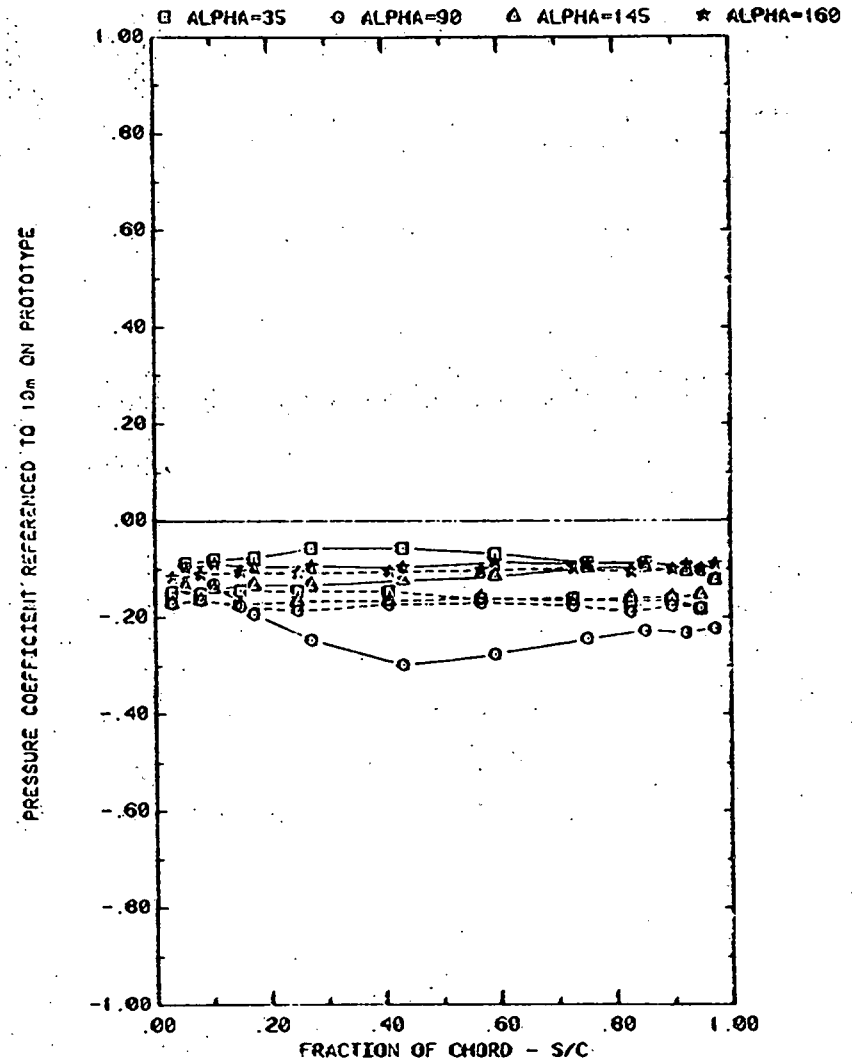

FRONT AND BACK PRESSURES ON ARRAY #2 WITH SEPARATION = $2C$
EFFECT OF ATTACK ANGLE WITH $H=3^\circ$, $P=30\%$, AND $D=5^\circ$

Plot 3-1. Multiple Arrays with Fence, $WD = 0^\circ$
Effect of Angle of Attack

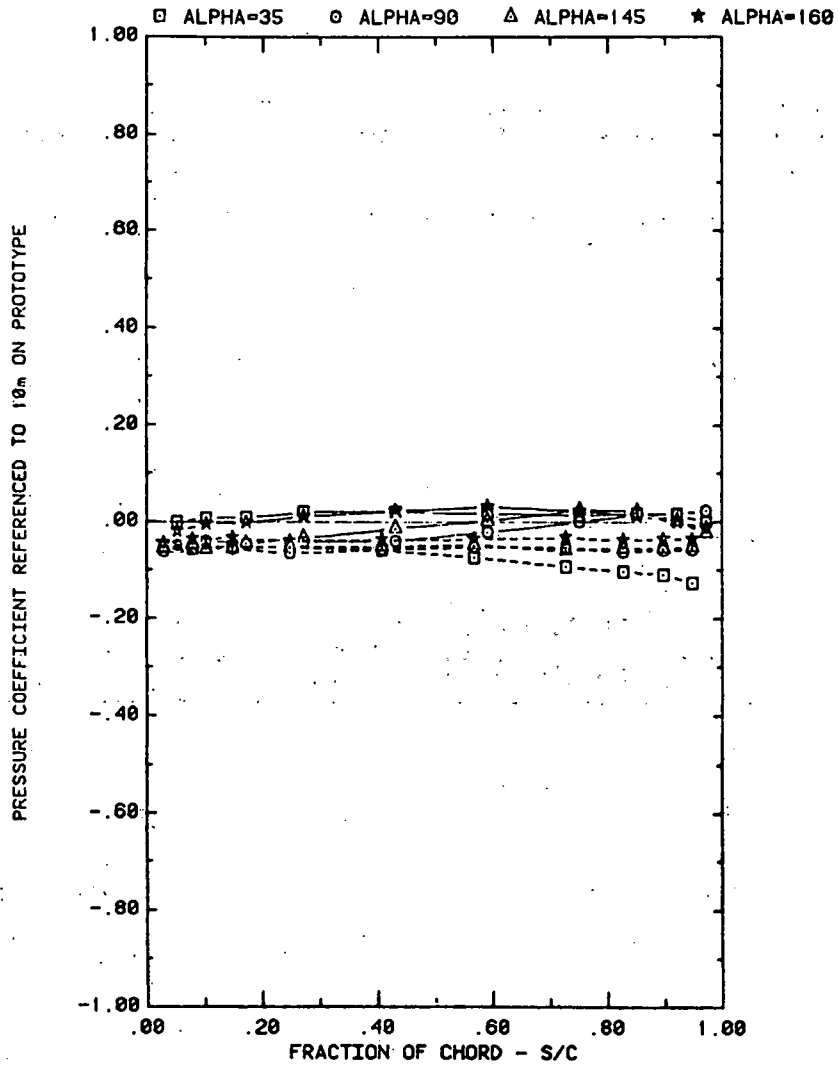

FRONT AND BACK PRESSURES ON ARRAY #5 WITH SEPARATION = $2C$
 EFFECT OF ATTACK ANGLE WITH $H=3^\circ$, $P=30\%$, AND $D=5^\circ$

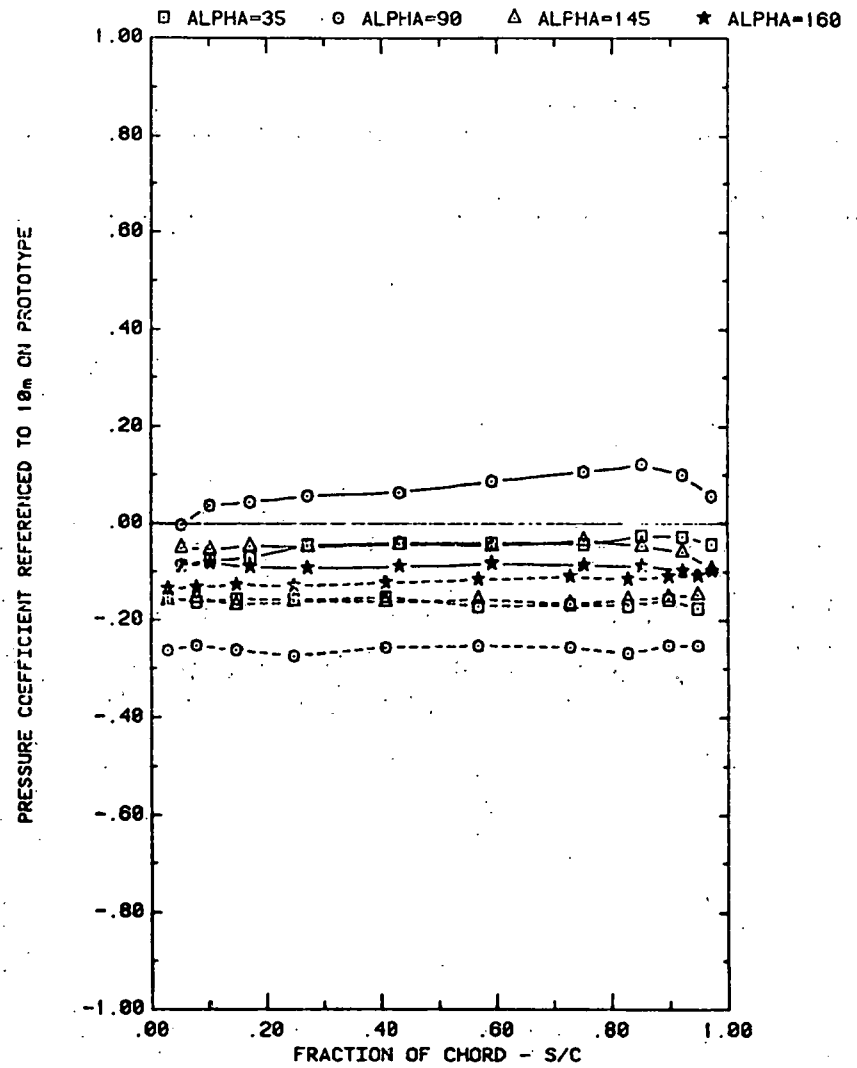

FRONT AND BACK PRESSURES ON ARRAY #1 WITH SEPARATION = $2C$
 EFFECT OF ATTACK ANGLE WITH $H=3^\circ$, $P=30\%$, AND $D=10^\circ$

Plot 3-1. (Continued)

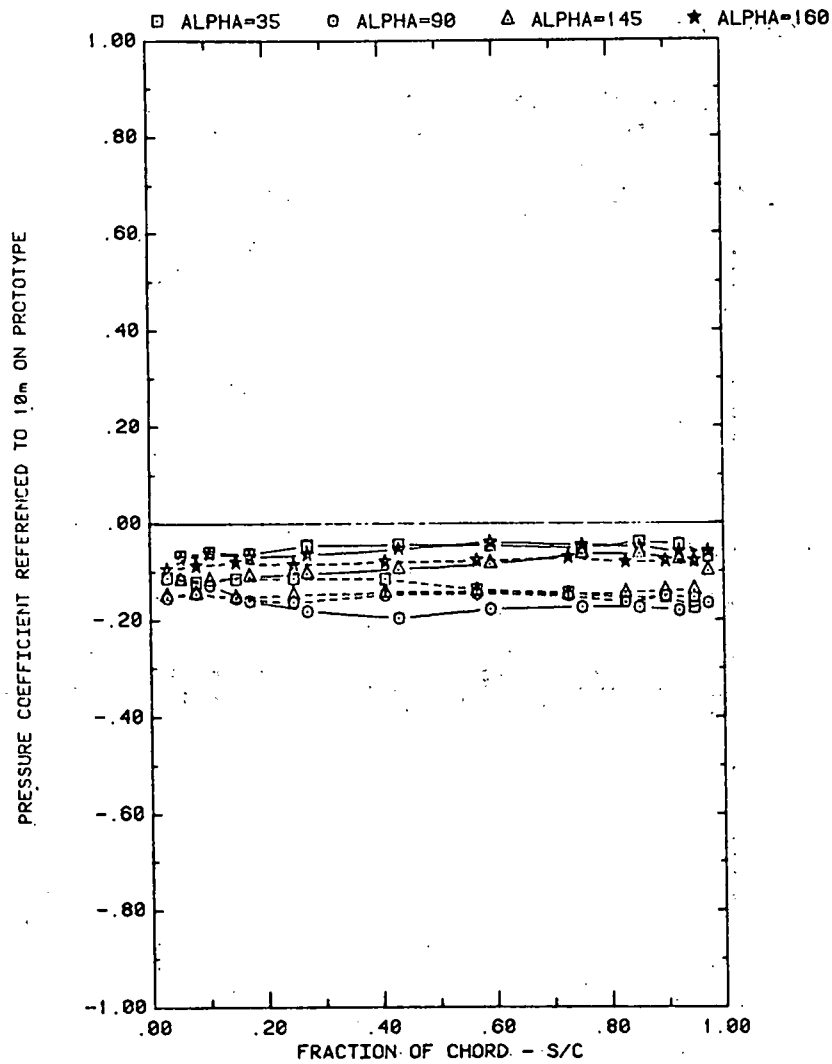

FRONT AND BACK PRESSURES ON ARRAY #2 WITH SEPARATION = 2C
 EFFECT OF ATTACK ANGLE WITH H=3", P=30%, AND D=10"

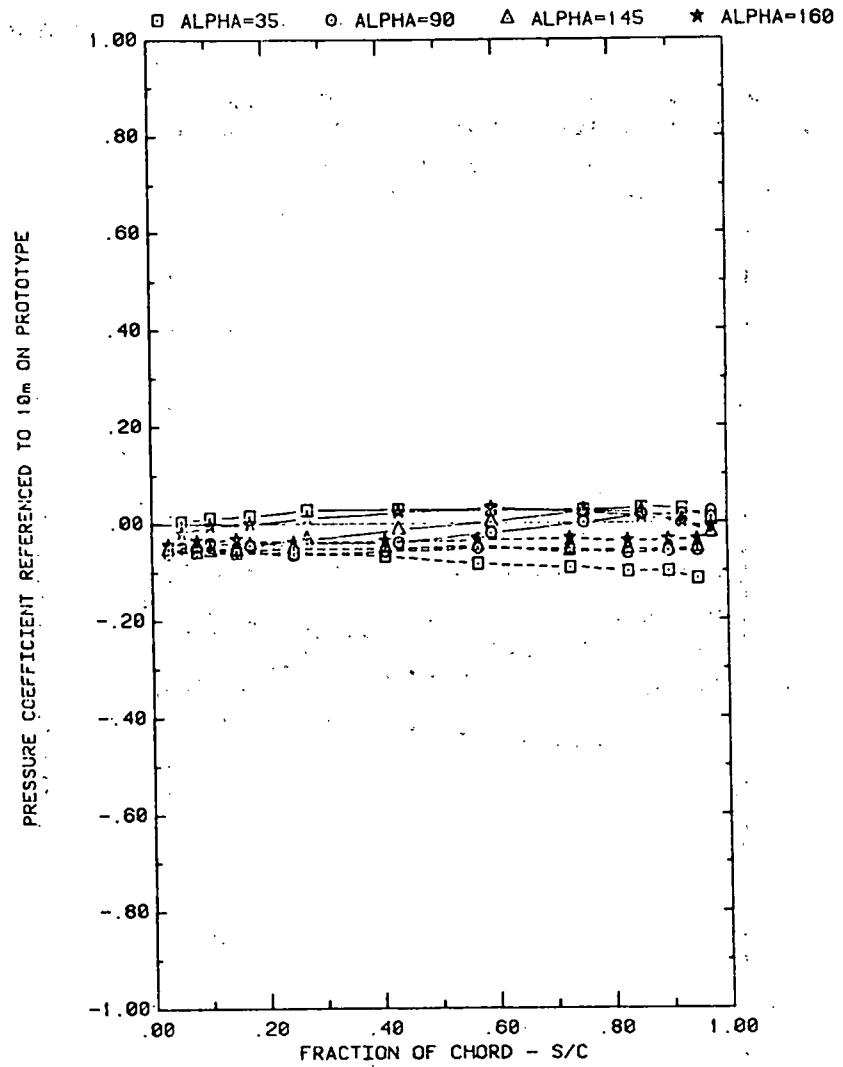

FRONT AND BACK PRESSURES ON ARRAY #5 WITH SEPARATION = 2C
 EFFECT OF ATTACK ANGLE WITH H=3", P=30%, AND D=10"

Plot 3-1. (Continued)

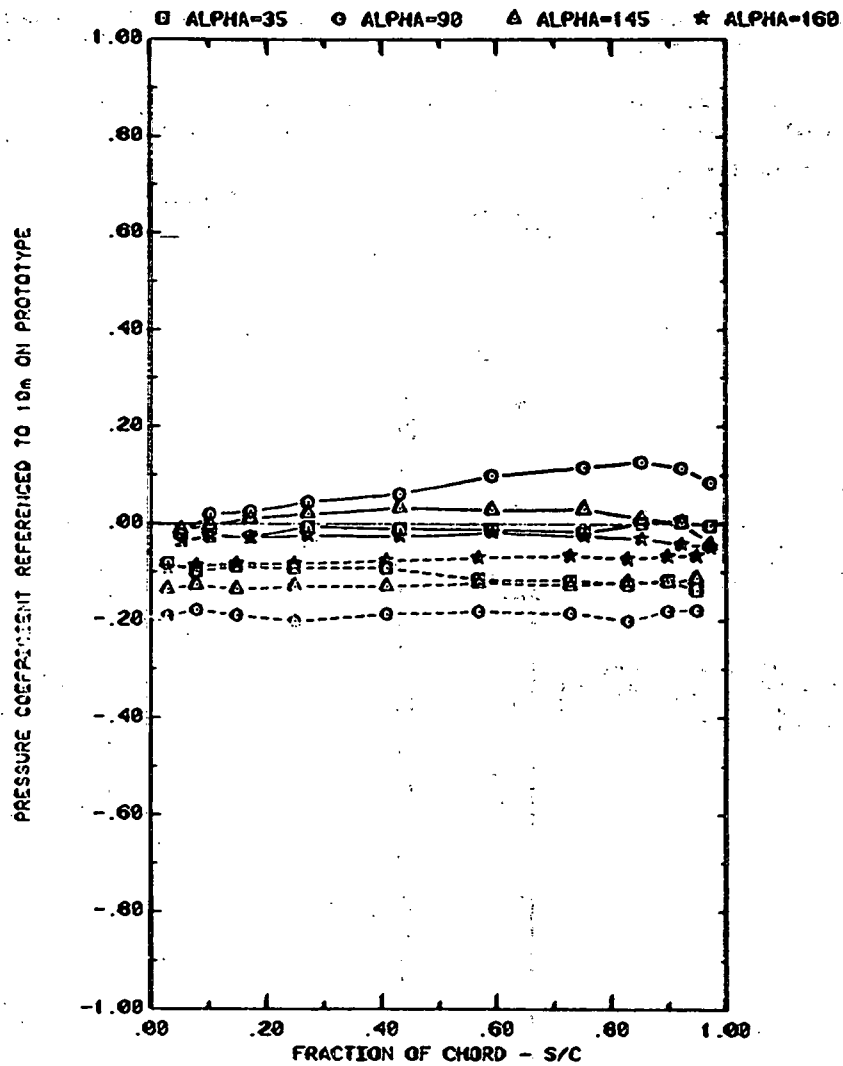

FRONT AND BACK PRESSURES ON ARRAY #1 WITH SEPARATION = 2C
 EFFECT OF ATTACK ANGLE WITH H=3", P=30%, AND D=20"

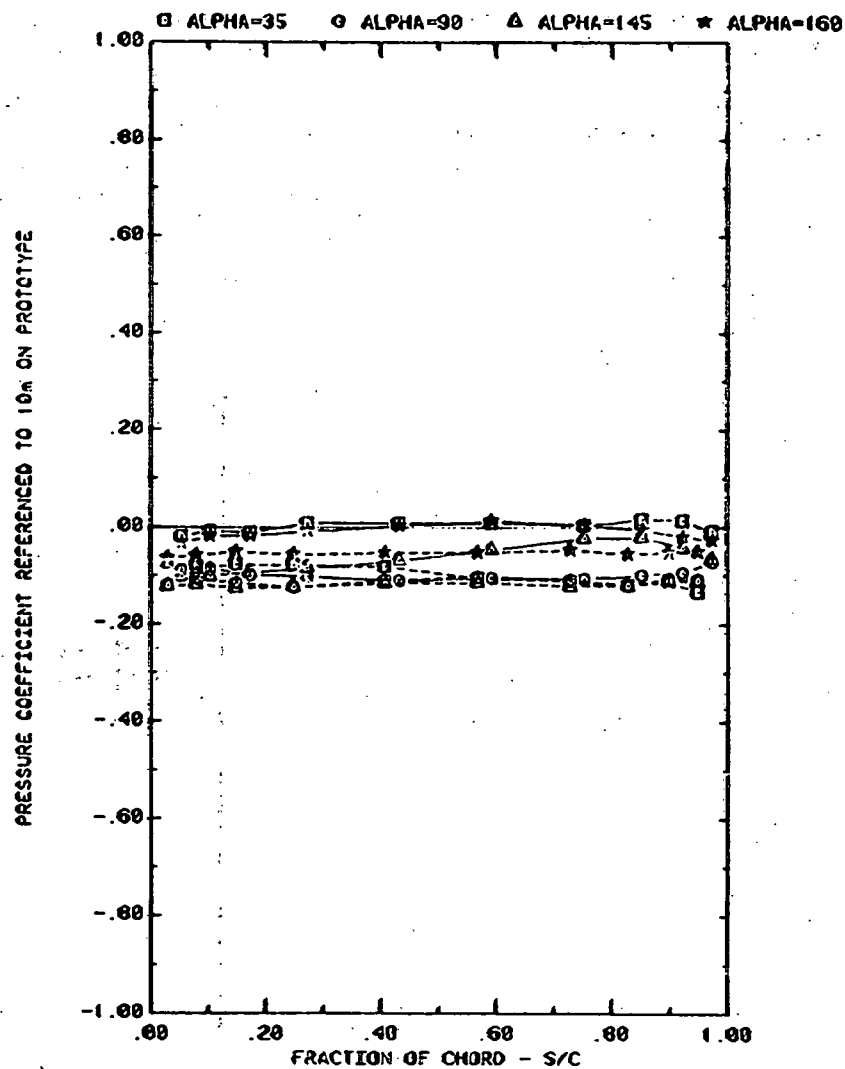

FRONT AND BACK PRESSURES ON ARRAY #2 WITH SEPARATION = 2C
 EFFECT OF ATTACK ANGLE WITH H=3", P=30%, AND D=20"

Plot 3-1. (Continued)

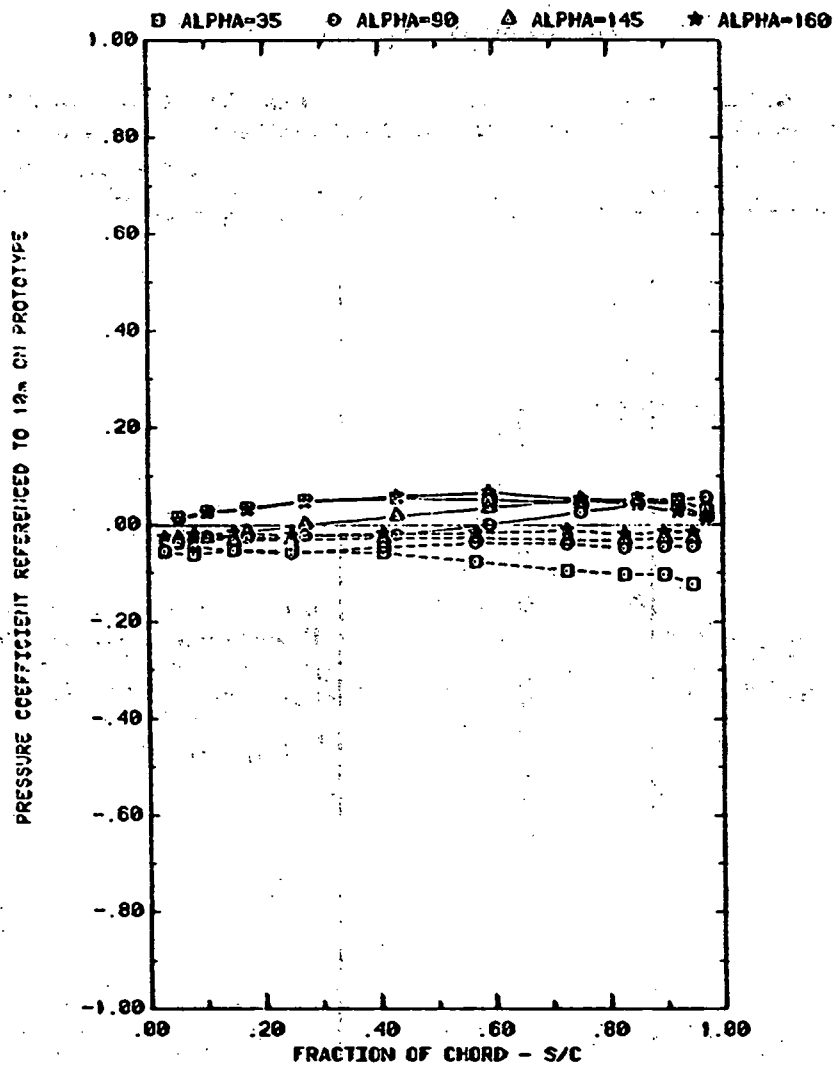

FRONT AND BACK PRESSURES ON ARRAY#5 WITH SEPARATION = 2C
 EFFECT OF ATTACK ANGLE WITH H=3", P=30%, AND D=20"

Plot 3-1. (Concluded)

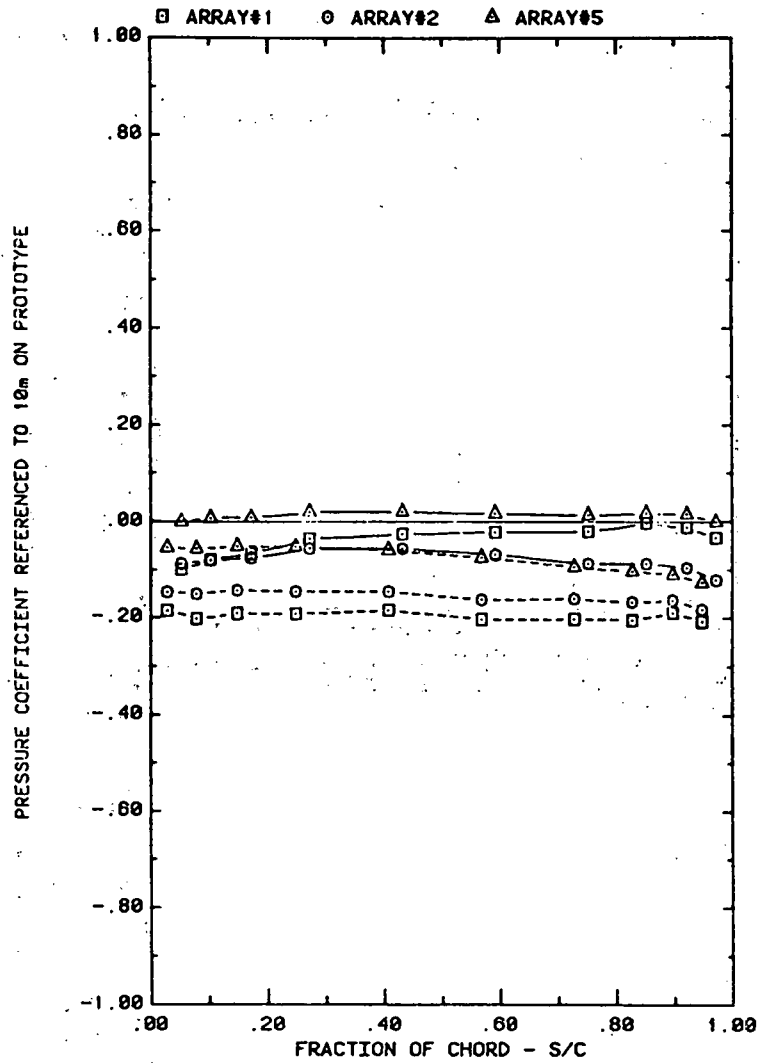

FRONT AND BACK PRESSURES ON VARIOUS ARRAYS WITH SEPARATION = 2C
EFFECT OF ARRAYS WITH ATTACK ANGLE=35, H=3°, P=30%, AND D=5°

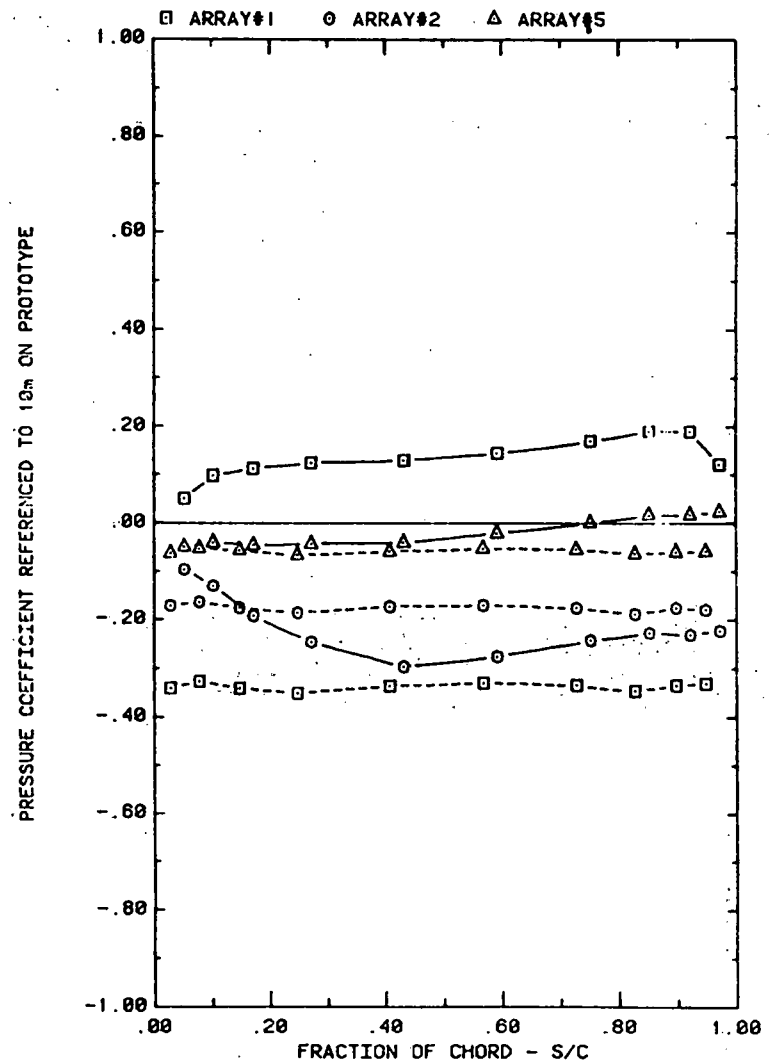

FRONT AND BACK PRESSURES ON VARIOUS ARRAYS WITH SEPARATION = 2C
EFFECT OF ARRAYS WITH ATTACK ANGLE=90, H=3°, P=30%, AND D=5°

Plot 3-2. Multiple Arrays with Fence, $WD = 0^\circ$
Effect of Array Position

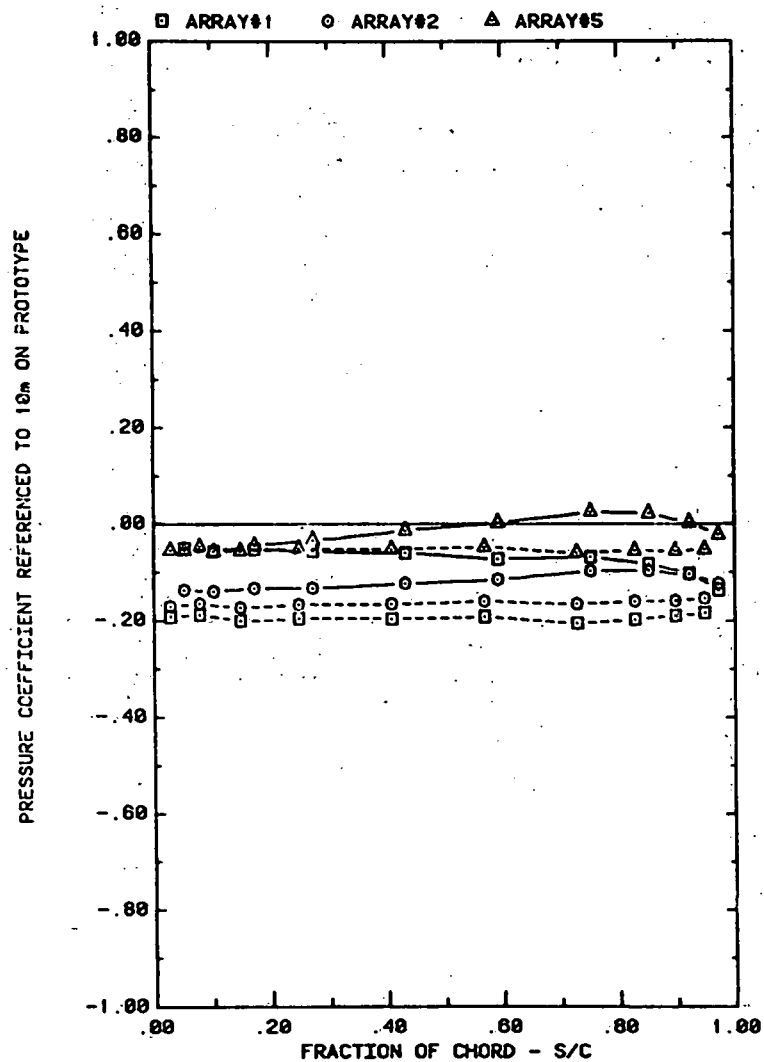

FRONT AND BACK PRESSURES ON VARIOUS ARRAYS WITH SEPARATION = 2C
EFFECT OF ARRAYS WITH ATTACK ANGLE=145, H=3°, P=30%, AND D=5°

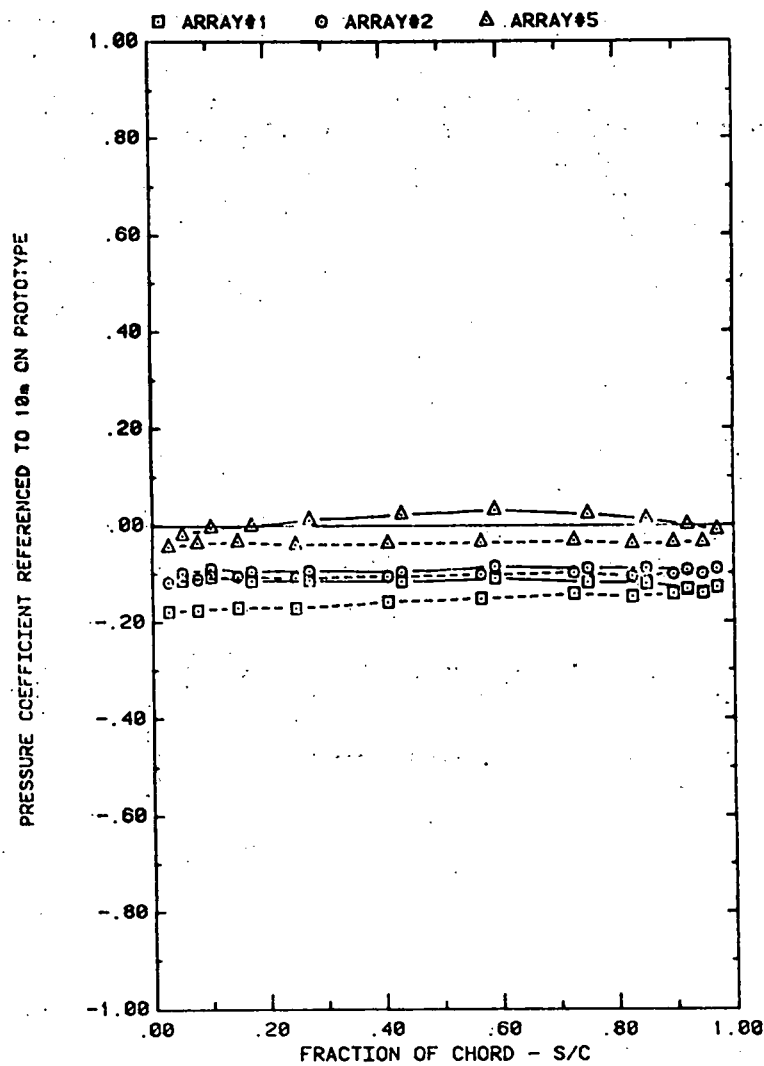

FRONT AND BACK PRESSURES ON VARIOUS ARRAYS WITH SEPARATION = 2C
EFFECT OF ARRAYS WITH ATTACK ANGLE=160, H=3°, P=30%, AND D=5°

Plot 3-2. (Continued)

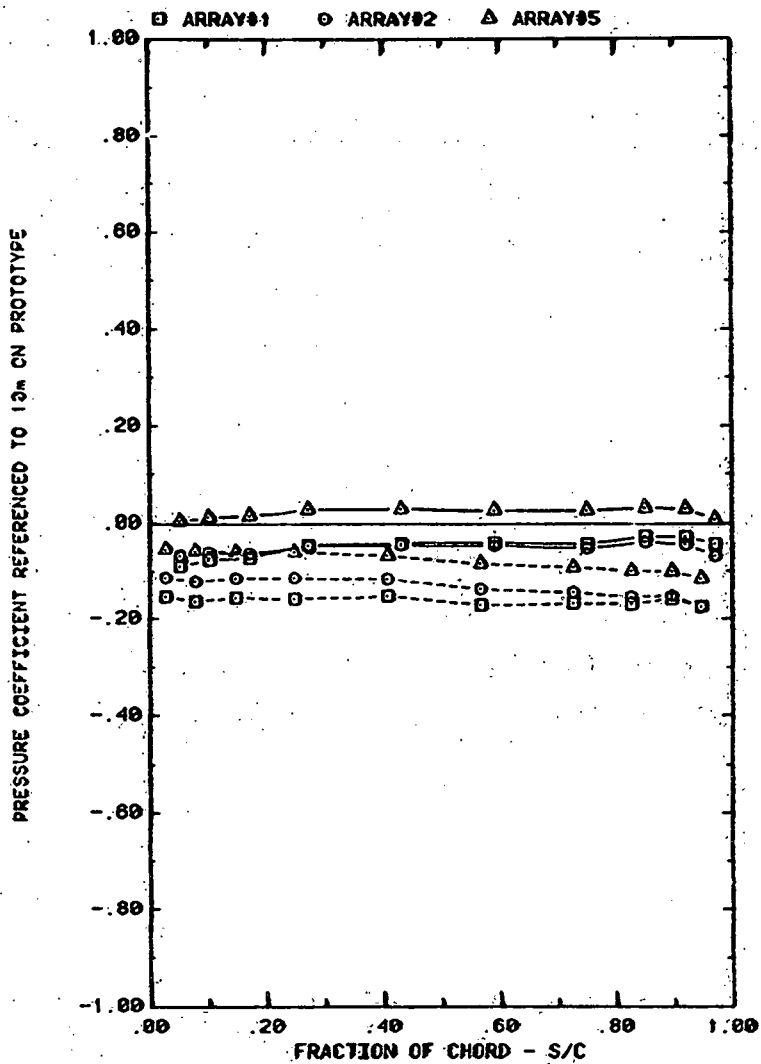

FRONT AND BACK PRESSURES ON VARIOUS ARRAYS WITH SEPARATION = 2C
 EFFECT OF ARRAYS WITH ATTACK ANGLE=35, H=3°, P=30%, AND D=10°

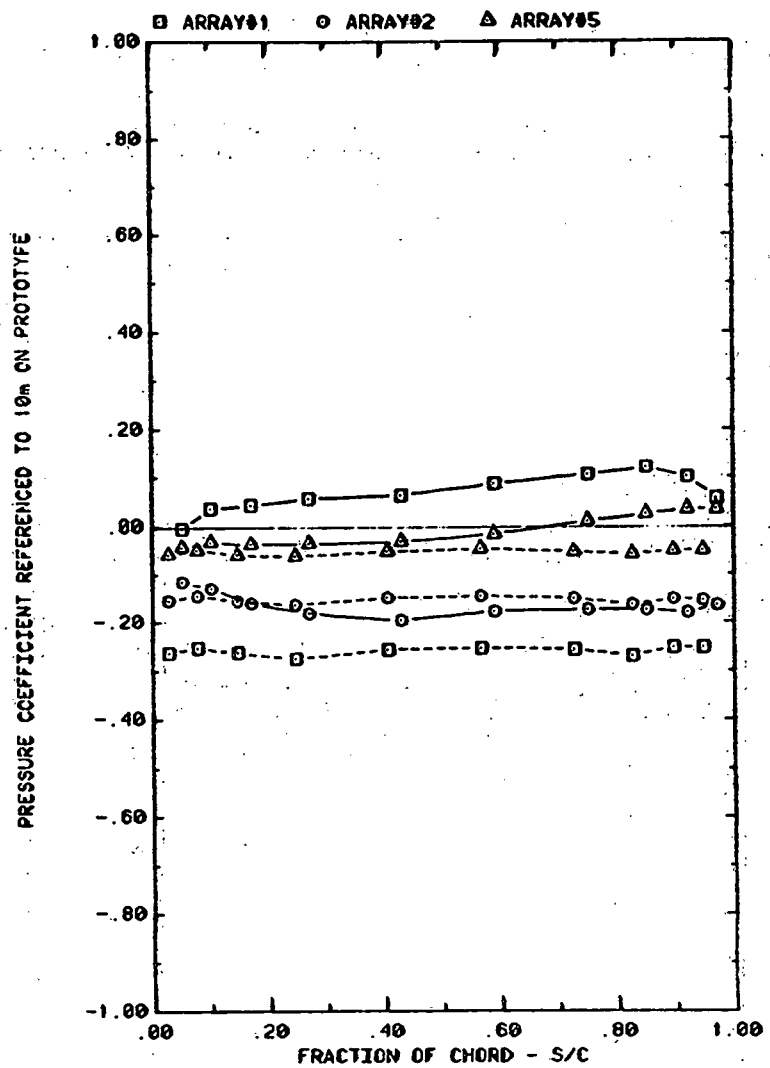

FRONT AND BACK PRESSURES ON VARIOUS ARRAYS WITH SEPARATION = 2C
 EFFECT OF ARRAYS WITH ATTACK ANGLE=90, H=3°, P=30%, AND D=10°

Plot 3-2. (Continued)

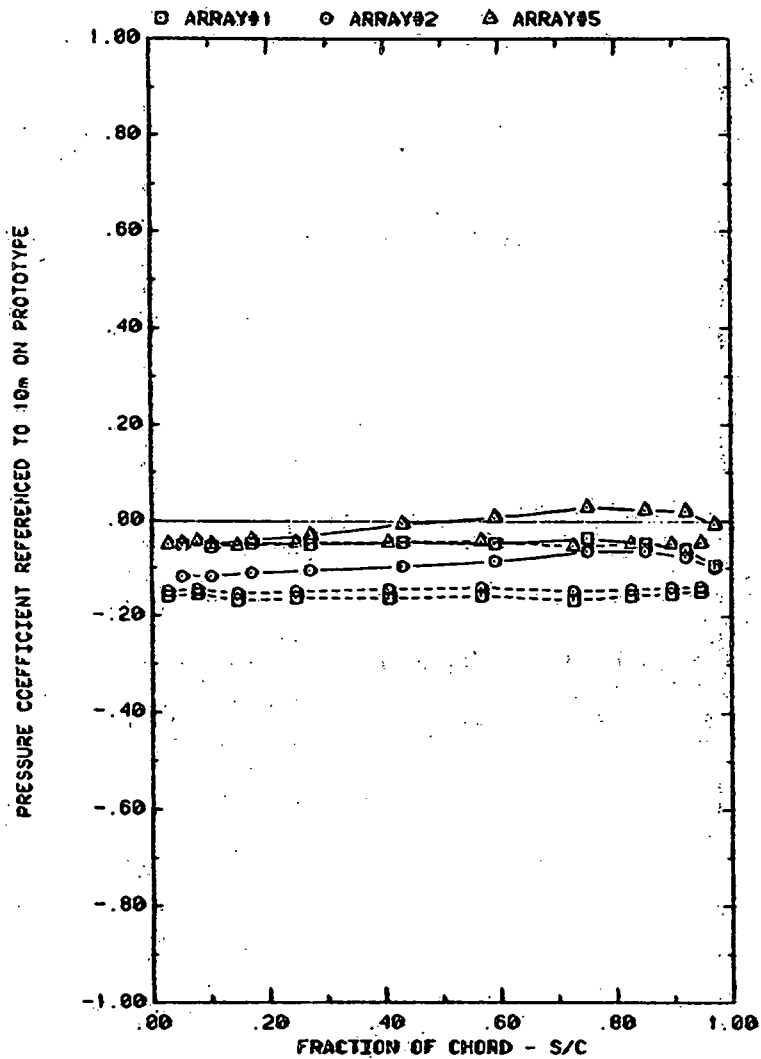

FRONT AND BACK PRESSURES ON VARIOUS ARRAYS WITH SEPARATION = 2C
EFFECT OF ARRAYS WITH ATTACK ANGLE=145, H=3°, P=30%, AND D=10°

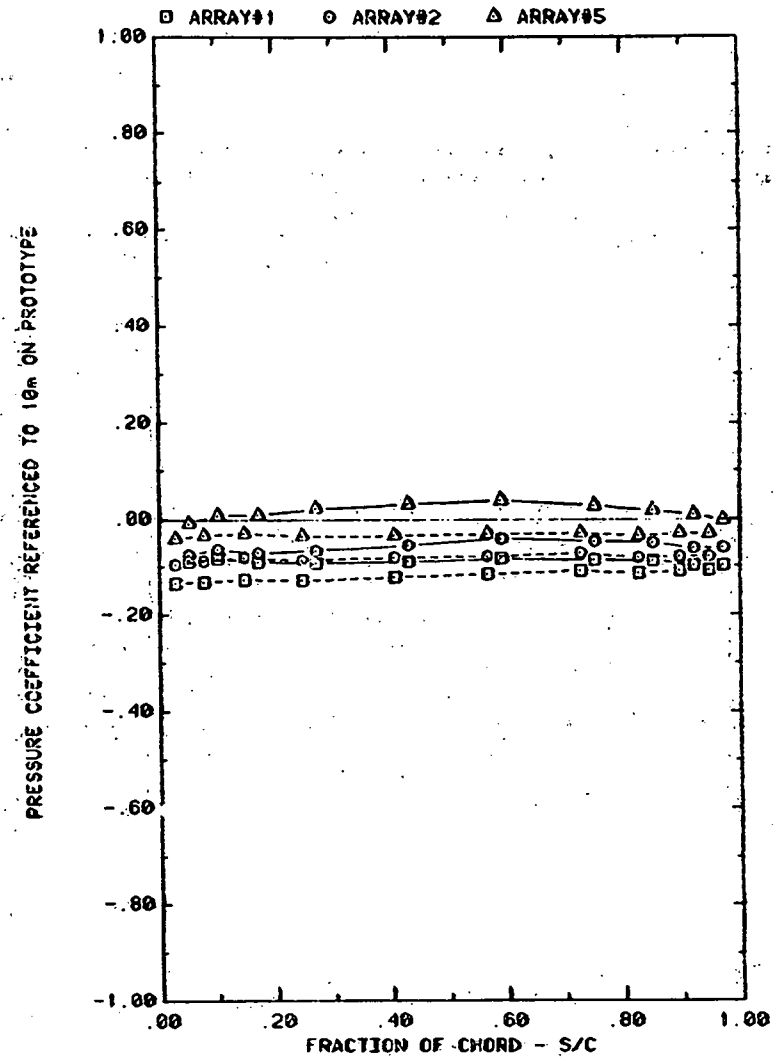

FRONT AND BACK PRESSURES ON VARIOUS ARRAYS WITH SEPARATION = 2C
EFFECT OF ARRAYS WITH ATTACK ANGLE=160, H=3°, P=30%, AND D=10°

Plot 3-2. (Continued)

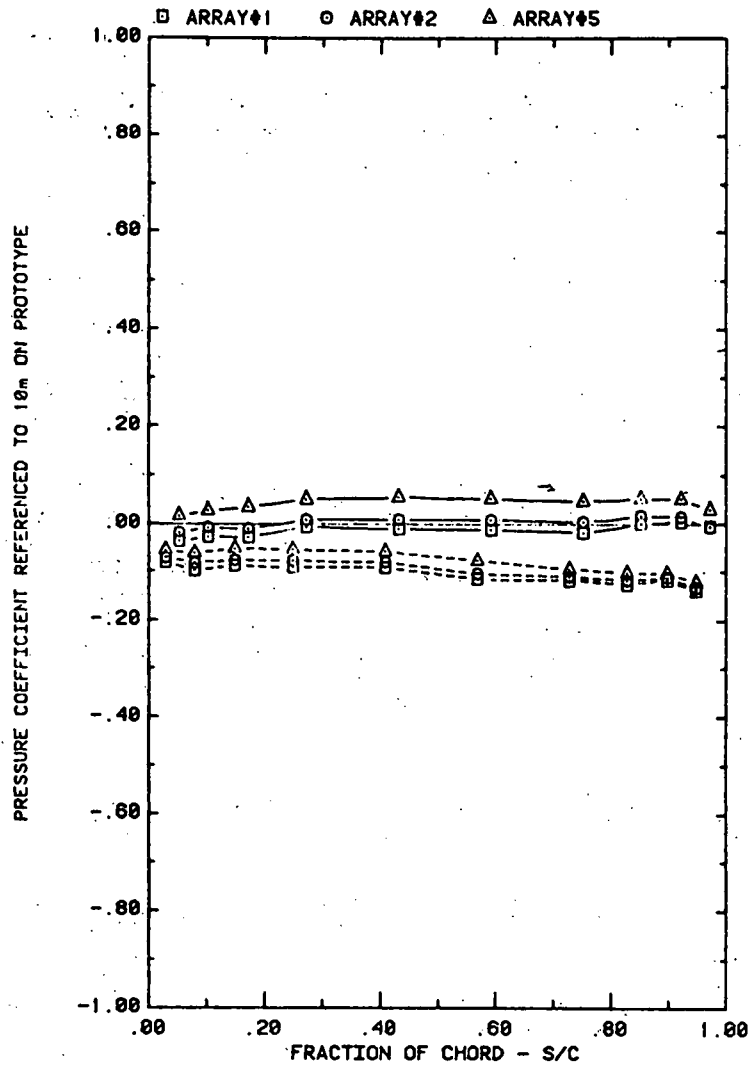

FRONT AND BACK PRESSURES ON VARIOUS ARRAYS WITH SEPARATION = 2C
EFFECT OF ARRAYS WITH ATTACK ANGLE=35°, H=3°, P=30%, AND D=20°

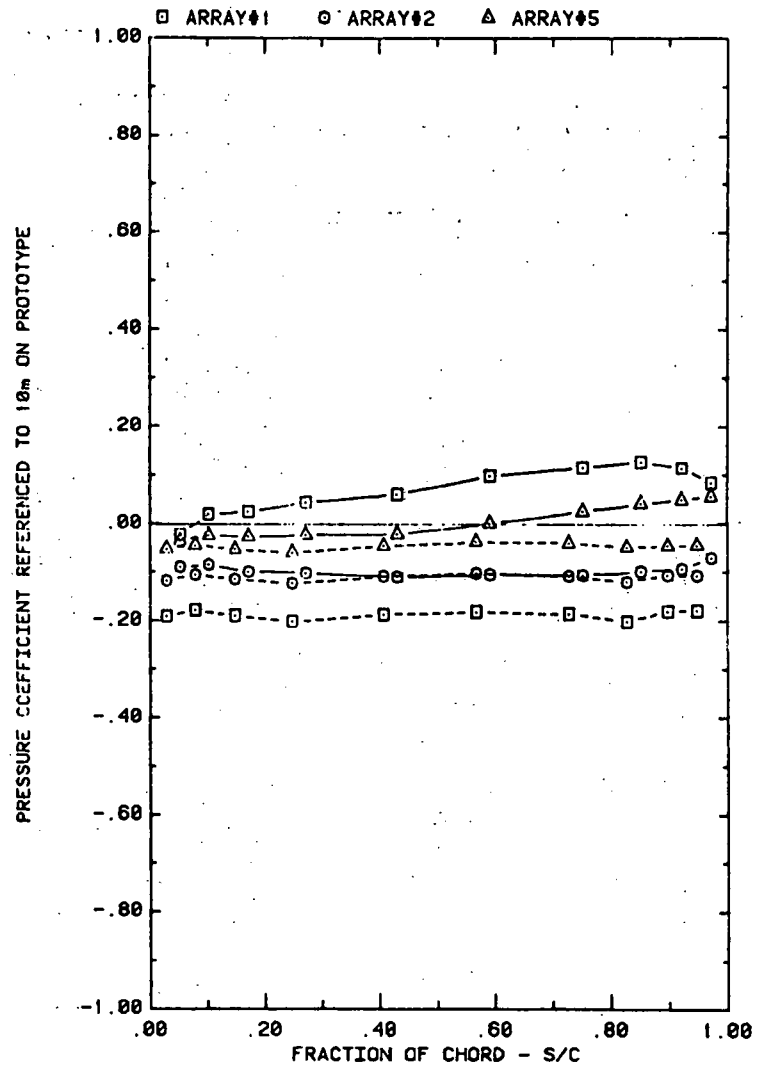

FRONT AND BACK PRESSURES ON VARIOUS ARRAYS WITH SEPARATION = 2C
EFFECT OF ARRAYS WITH ATTACK ANGLE=90°, H=3°, P=30%, AND D=20°

Plot 3-2. (Continued)

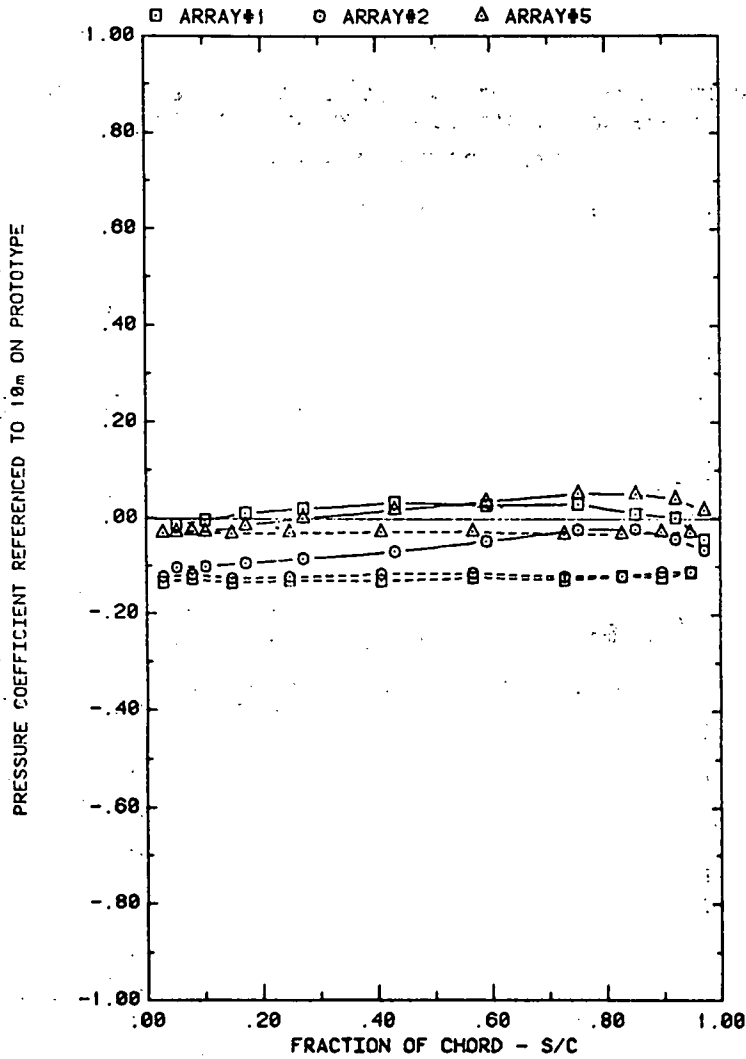

FRONT AND BACK PRESSURES ON VARIOUS ARRAYS WITH SEPARATION = 2C
EFFECT OF ARRAYS WITH ATTACK ANGLE=145, H=3°, P=30%, AND D=20°

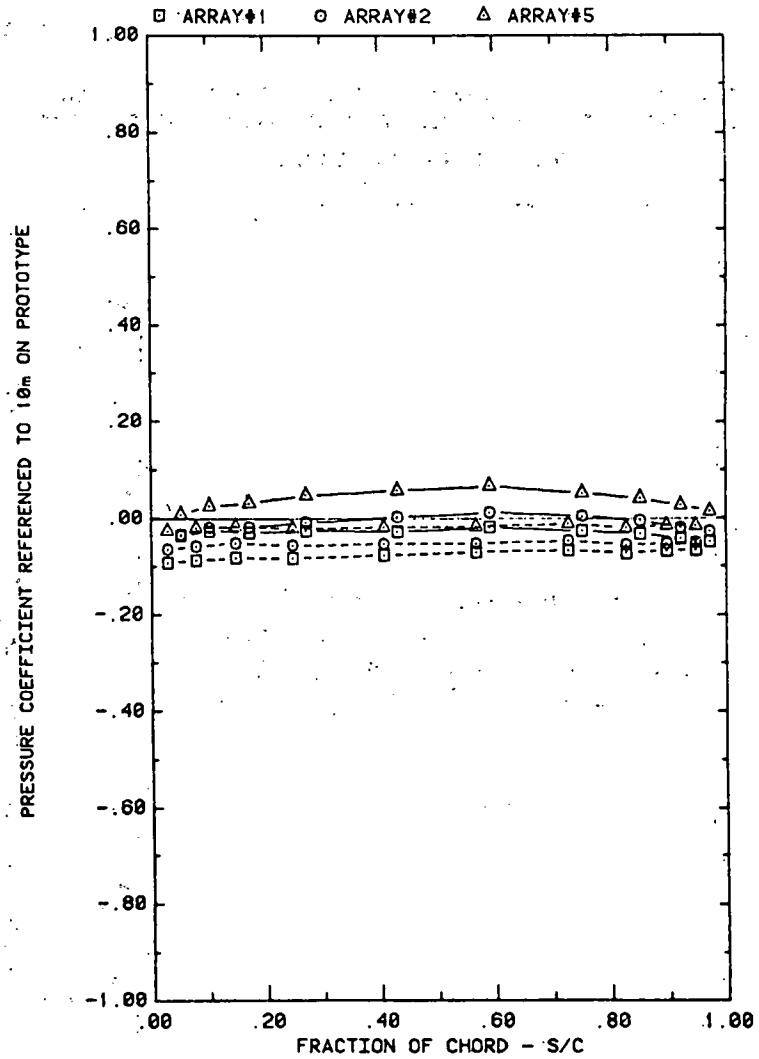

FRONT AND BACK PRESSURES ON VARIOUS ARRAYS WITH SEPARATION = 2C
EFFECT OF ARRAYS WITH ATTACK ANGLE=160, H=3°, P=30%, AND D=20°

Plot 3-2. (Concluded)

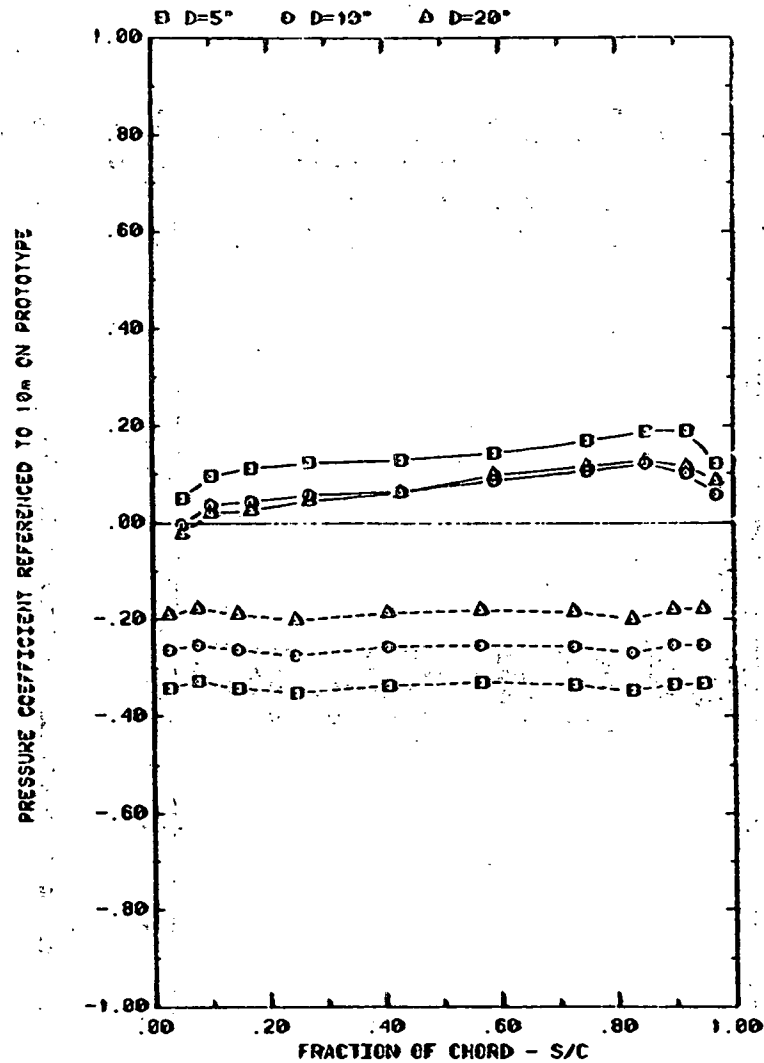
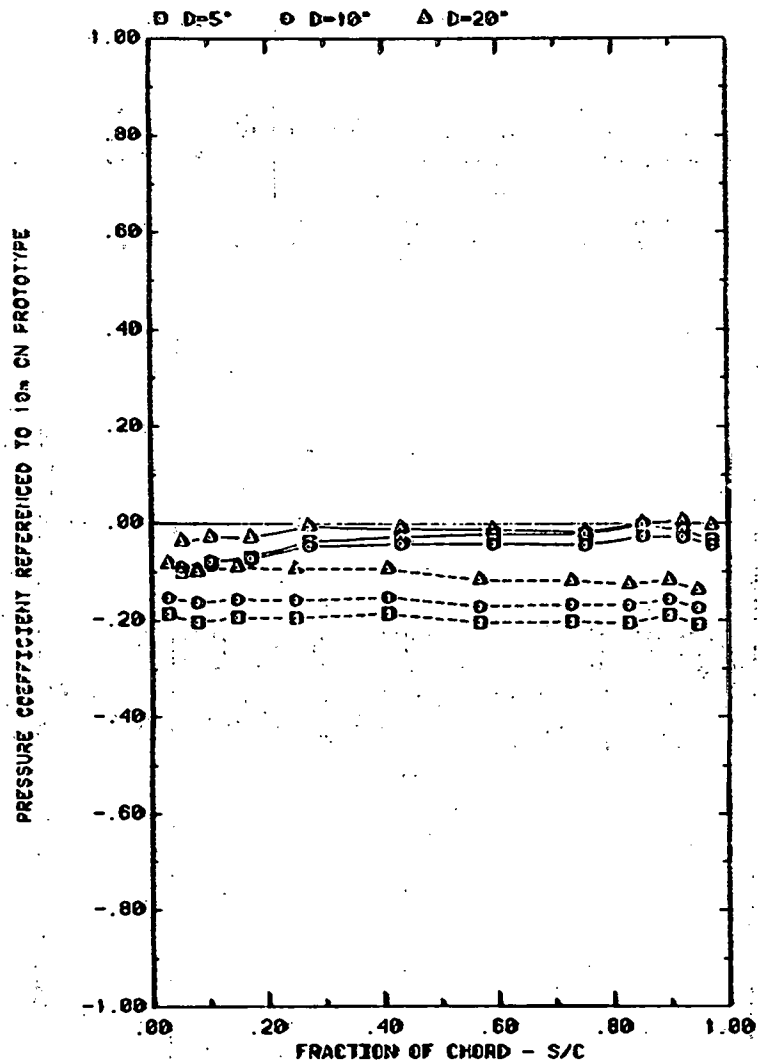

FRONT AND BACK PRESSURES ON ARRAY #1 WITH SEPARATION = 2C
EFFECT OF FENCE DISTANCE WITH $H=3^\circ$, $P=30\%$, AND $\alpha=35^\circ$

FRONT AND BACK PRESSURES ON ARRAY #1 WITH SEPARATION = 2C
EFFECT OF FENCE DISTANCE WITH $H=3^\circ$, $P=30\%$, AND $\alpha=90^\circ$

Plot 3-3. Multiple Arrays with Fence, $WD = 0^\circ$
Effect of Fence Distance

PRESSURE COEFFICIENT REFERENCED TO 10m ON PROTOTYPE

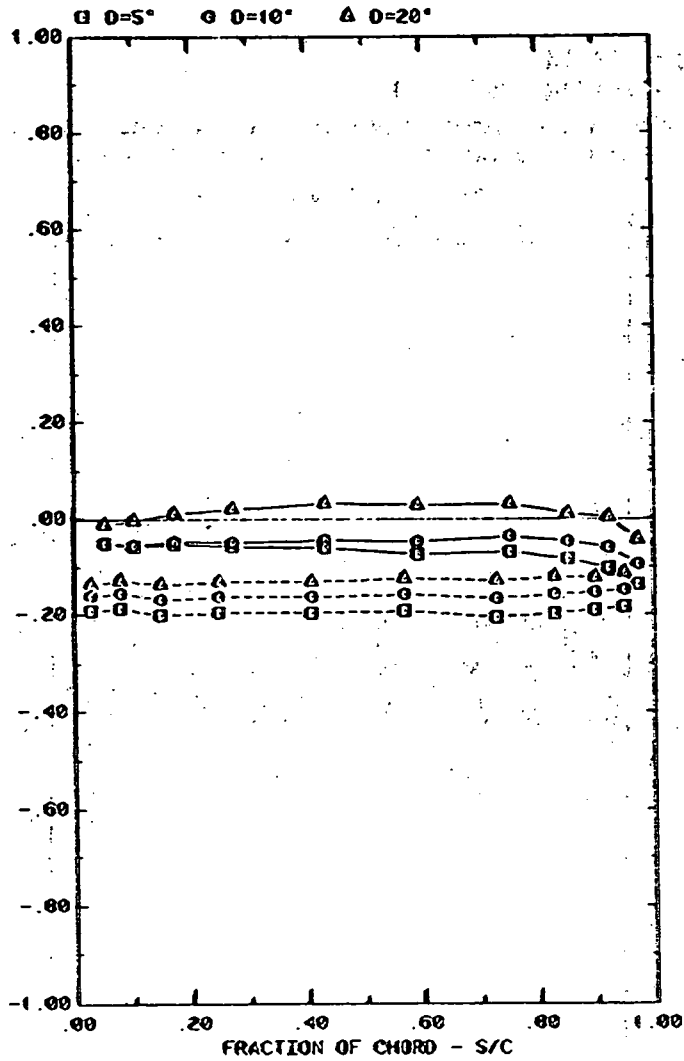

FRONT AND BACK PRESSURES ON ARRAY #1 WITH SEPARATION = 2C
EFFECT OF FENCE DISTANCE WITH $H=3^\circ$, $P=30\%$, AND $\alpha=145$

PRESSURE COEFFICIENT REFERENCED TO 10m ON PROTOTYPE

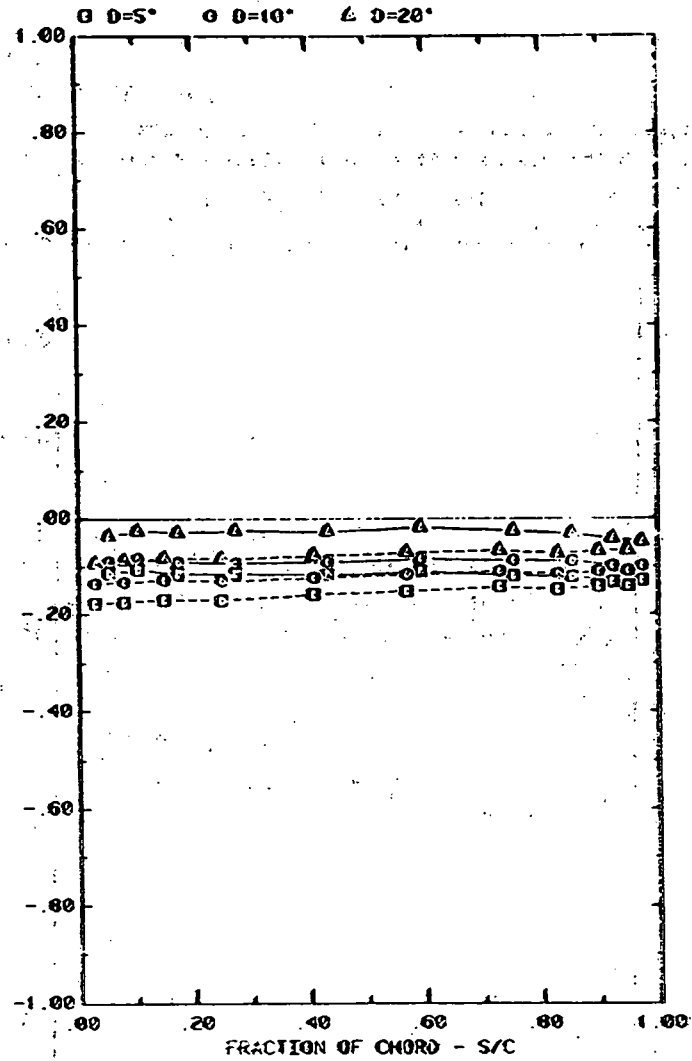

FRONT AND BACK PRESSURES ON ARRAY #1 WITH SEPARATION = 2C
EFFECT OF FENCE DISTANCE WITH $H=3^\circ$, $P=30\%$, AND $\alpha=160$

Plot 3-3. (Continued)

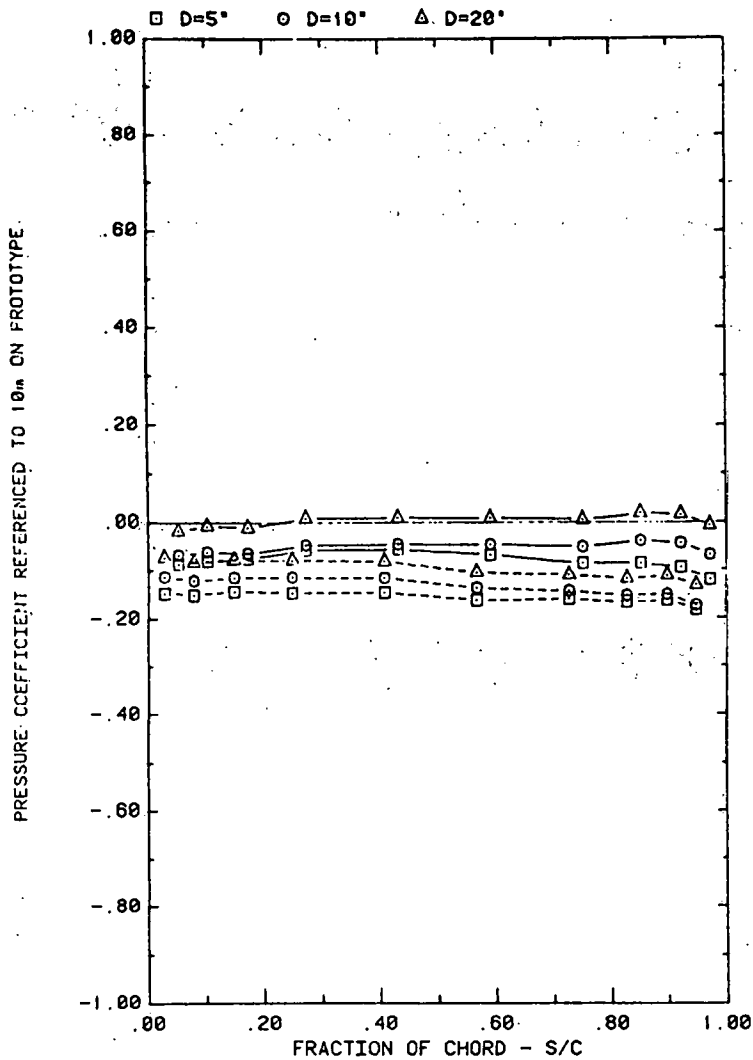

FRONT AND BACK PRESSURES ON ARRAY #2 WITH SEPARATION = 2C
EFFECT OF FENCE DISTANCE WITH H=3°, P=30%, AND ALPHA=35

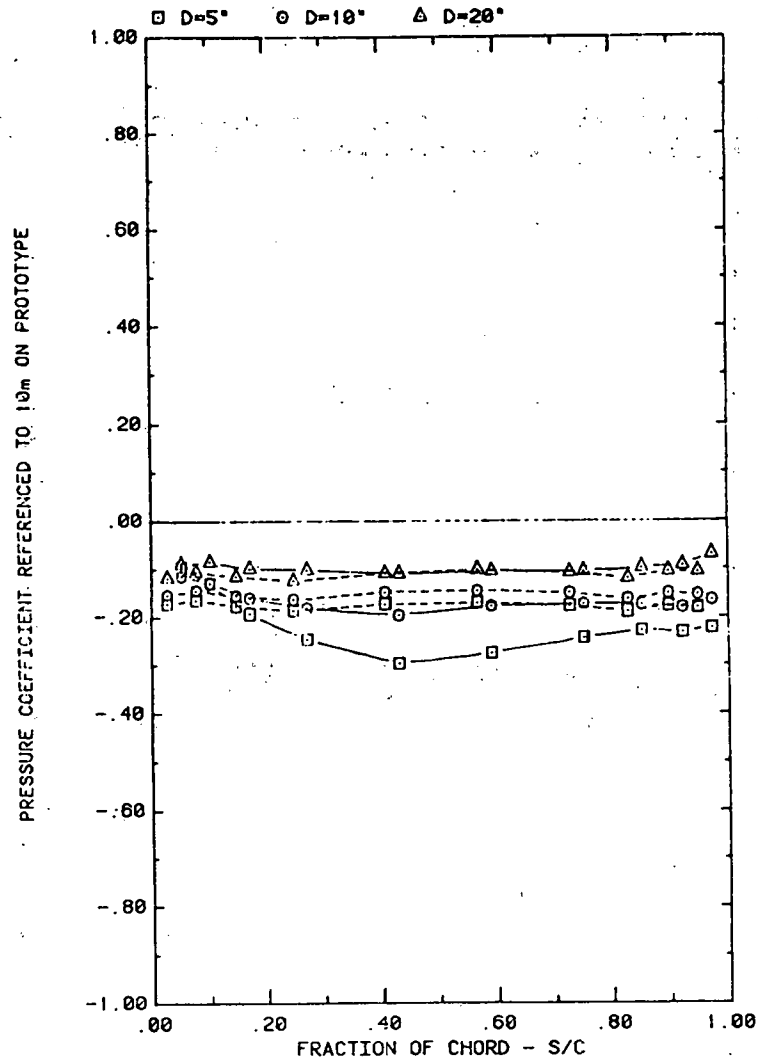

FRONT AND BACK PRESSURES ON ARRAY #2 WITH SEPARATION = 2C
EFFECT OF FENCE DISTANCE WITH H=3°, P=30%, AND ALPHA=90

Plot 3-3. (Continued)

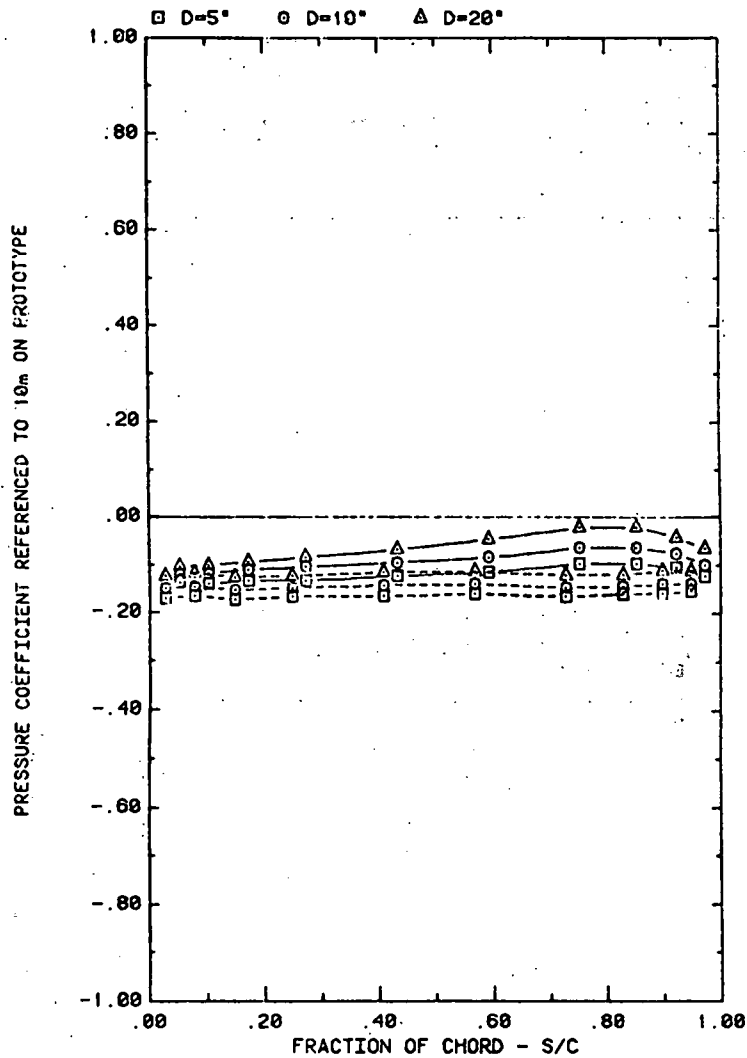

FRONT AND BACK PRESSURES ON ARRAY #2 WITH SEPARATION = 2C
EFFECT OF FENCE DISTANCE WITH H=3", P=30%, AND ALPHA=145

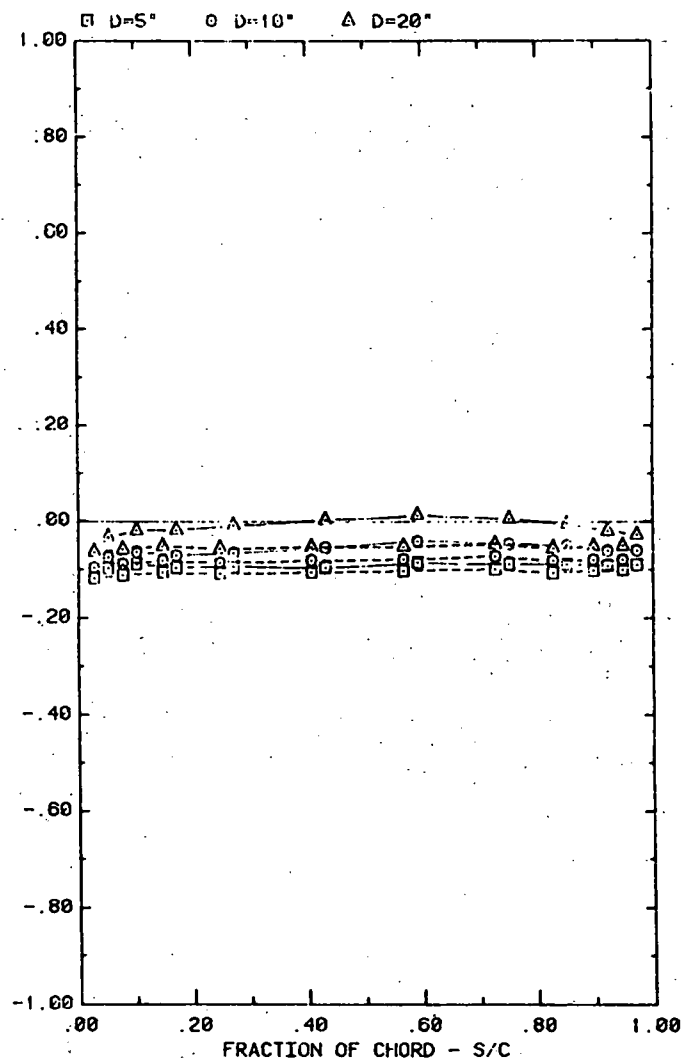

FRONT AND BACK PRESSURES ON ARRAY #2 WITH SEPARATION = 2C
EFFECT OF FENCE DISTANCE WITH H=3", P=30%, AND ALPHA=160

Plot 3-3. (Continued)

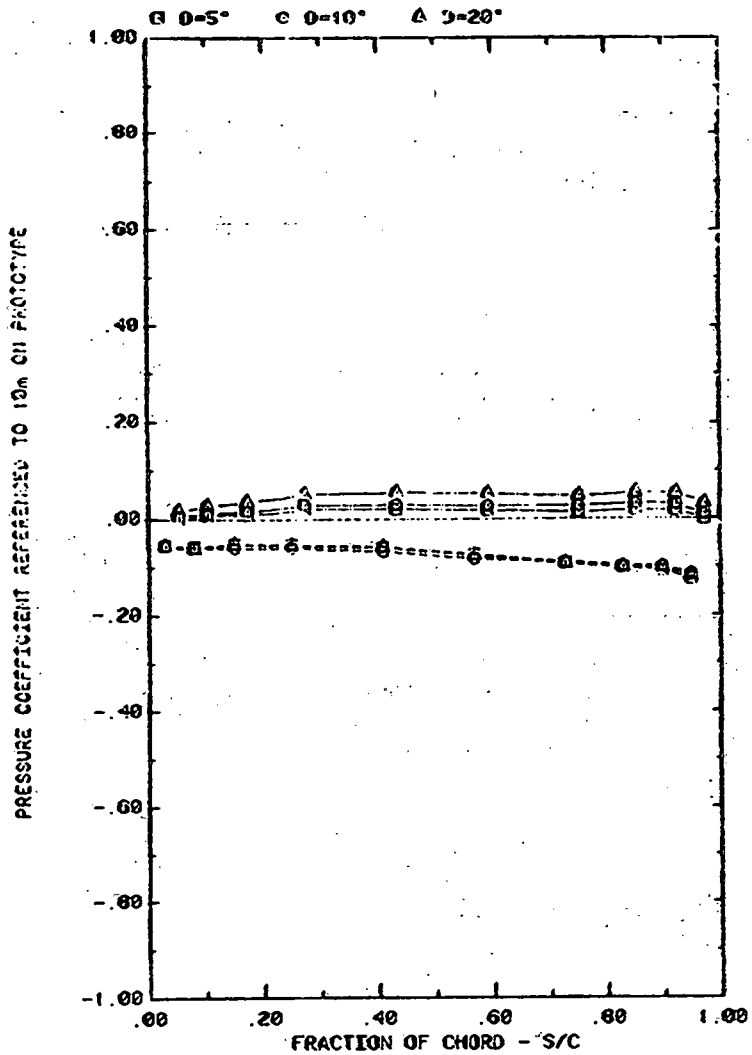

FRONT AND BACK PRESSURES ON ARRAY #5 WITH SEPARATION = 2C
 EFFECT OF FENCE DISTANCE WITH $H=3^\circ$, $P=30\%$, AND $\alpha=35$

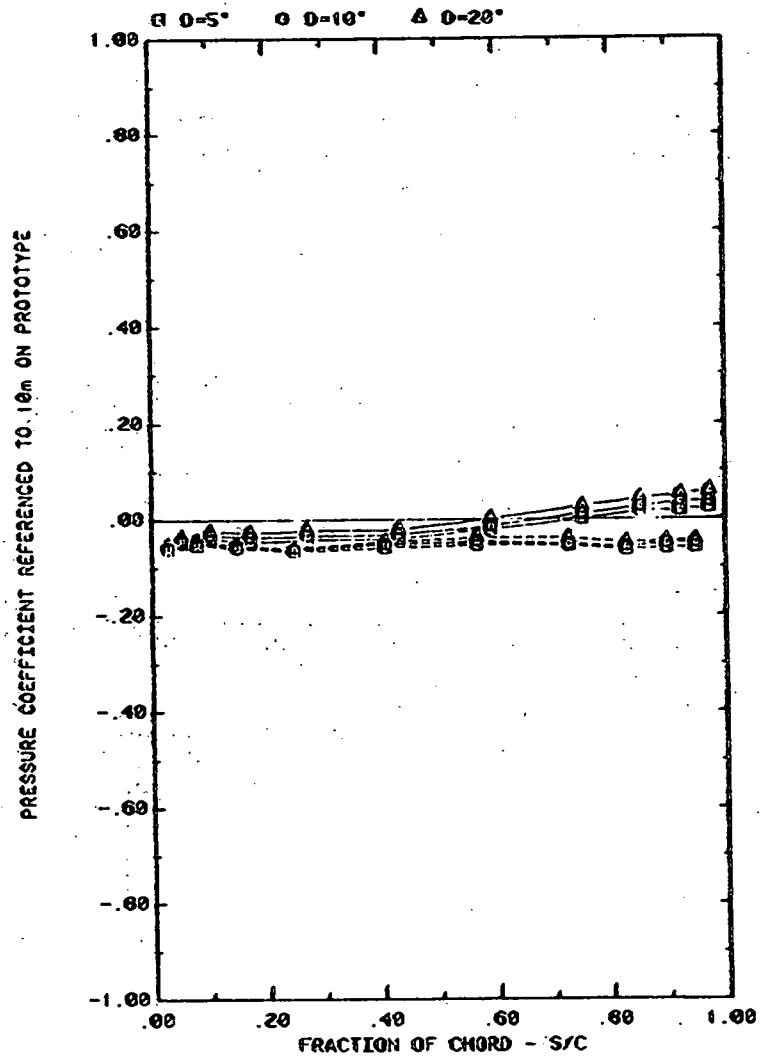

FRONT AND BACK PRESSURES ON ARRAY #5 WITH SEPARATION = 2C
 EFFECT OF FENCE DISTANCE WITH $H=3^\circ$, $P=30\%$, AND $\alpha=90$

Plot 3-3. (Continued)

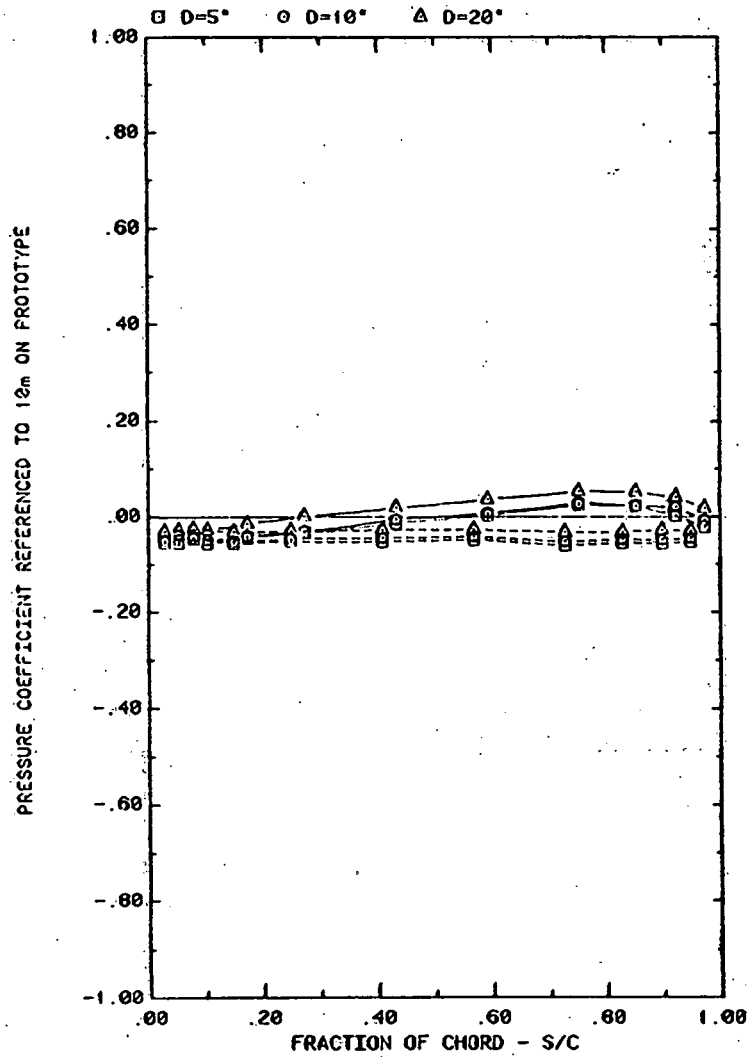

FRONT AND BACK PRESSURES ON ARRAY #5 WITH SEPARATION = .2C
 EFFECT OF FENCE DISTANCE WITH $H=3^\circ$, $P=30\%$, AND $\alpha=145$

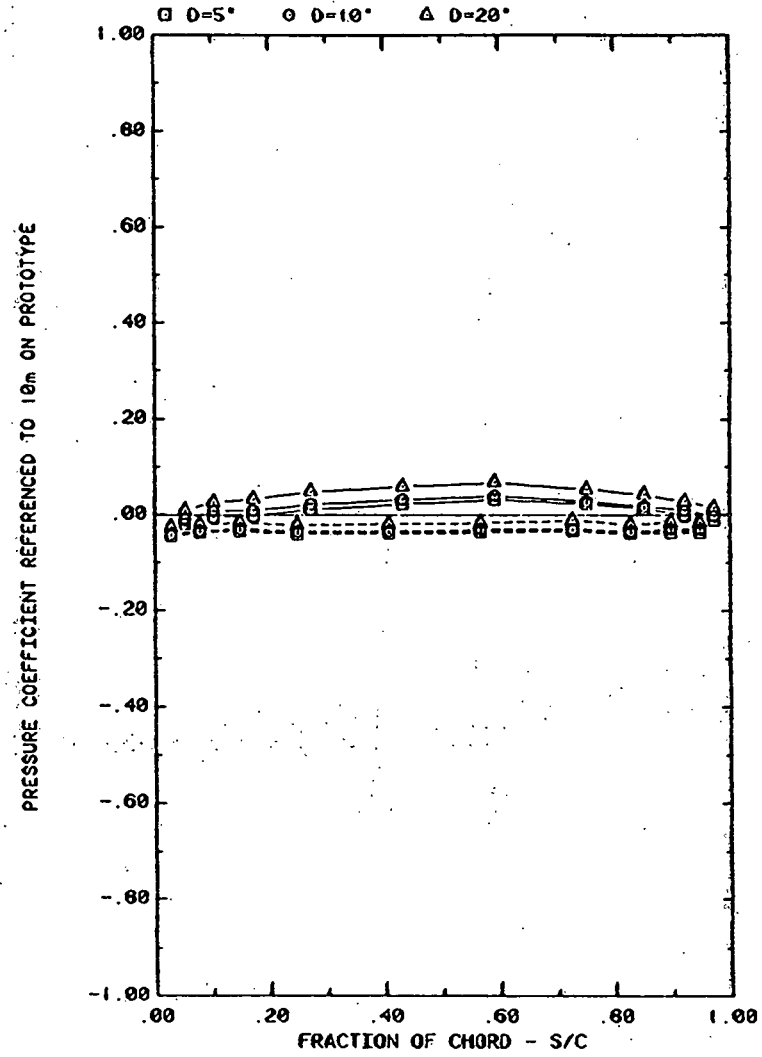

FRONT AND BACK PRESSURES ON ARRAY #5 WITH SEPARATION = .2C
 EFFECT OF FENCE DISTANCE WITH $H=3^\circ$, $P=30\%$, AND $\alpha=160$

Plot 3-3. (Concluded)

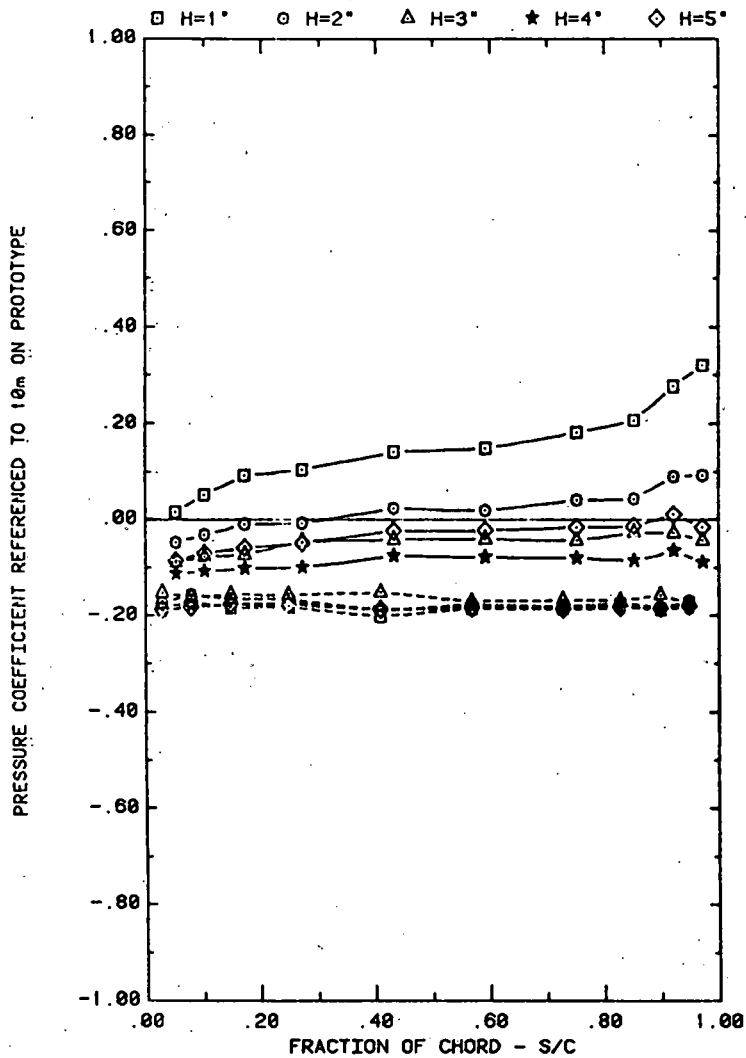

FRONT AND BACK PRESSURES ON ARRAY #1 WITH SEPARATION = 2C
EFFECT OF FENCE HEIGHT WITH ALPHA=35, D=10°, AND P=30%

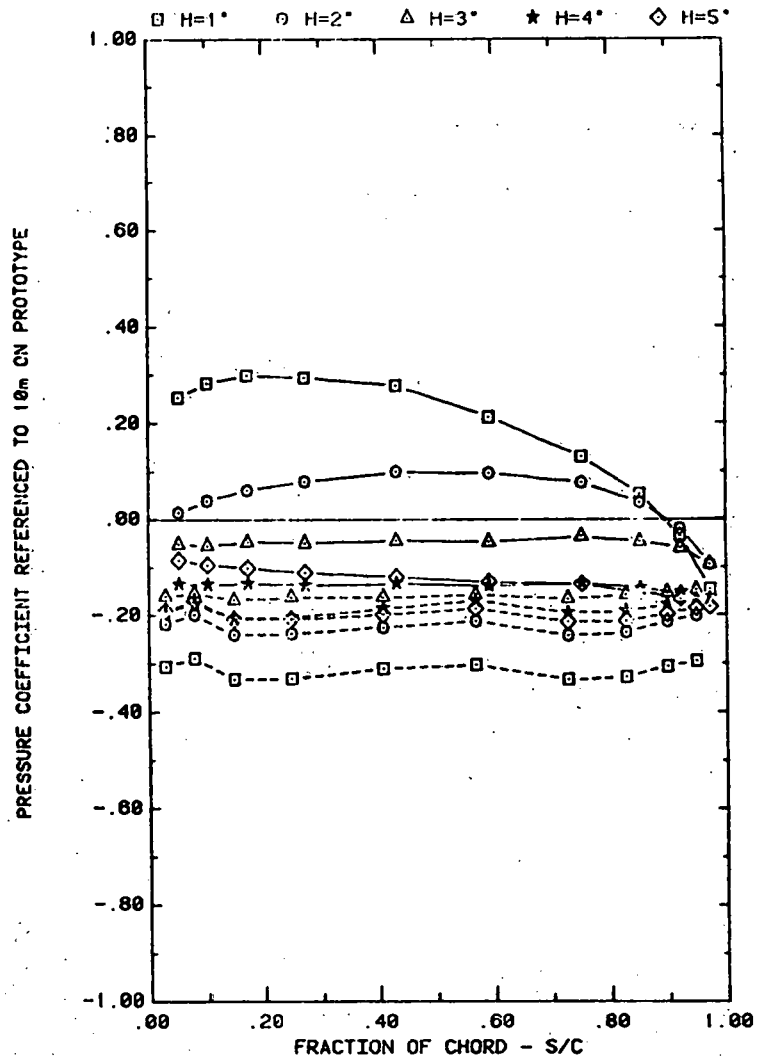

FRONT AND BACK PRESSURES ON ARRAY #1 WITH SEPARATION = 2C
EFFECT OF FENCE HEIGHT WITH ALPHA=145, D=10°, AND P=30%

Plot 3-4. Multiple Arrays with Fence, $WD = 0^\circ$
Effect of Fence Height

PRESSURE COEFFICIENT REFERENCED TO 10m ON PROTOTYPE

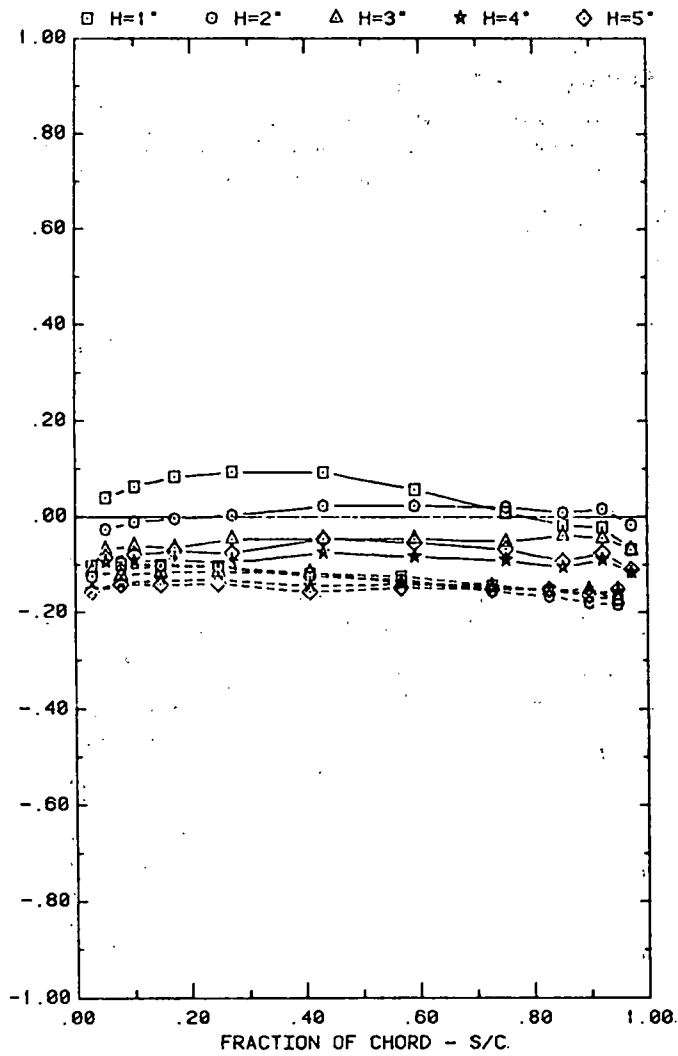

FRONT AND BACK PRESSURES ON ARRAY #2 WITH SEPARATION = 2C
EFFECT OF FENCE HEIGHT WITH ALPHA=35, D=10°, AND P=30%

PRESSURE COEFFICIENT REFERENCED TO 10m ON PROTOTYPE

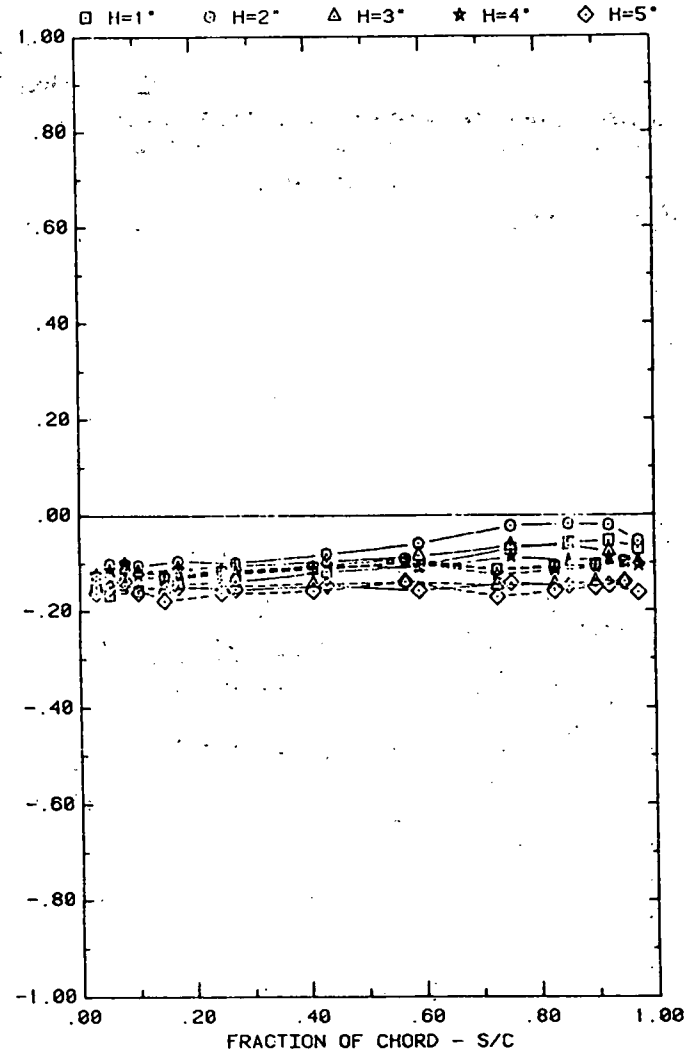

FRONT AND BACK PRESSURES ON ARRAY #2 WITH SEPARATION = 2C
EFFECT OF FENCE HEIGHT WITH ALPHA=145, D=10°, AND P=30%

Plot 3-4. (Continued)

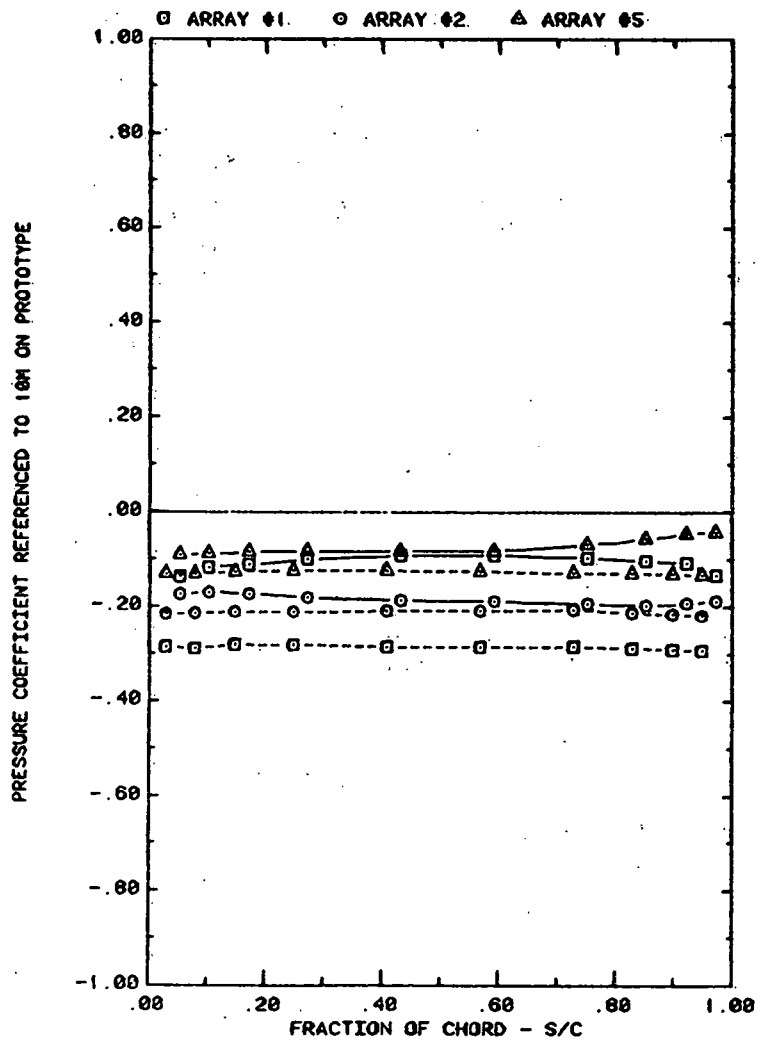

FRONT AND BACK PRESSURES ON ARRAYS #1, #2, #5 WITH SEPARATION = 2C
EFFECT OF ARRAY WITH ALPHA = 60, WIND = 0, HF = 4°

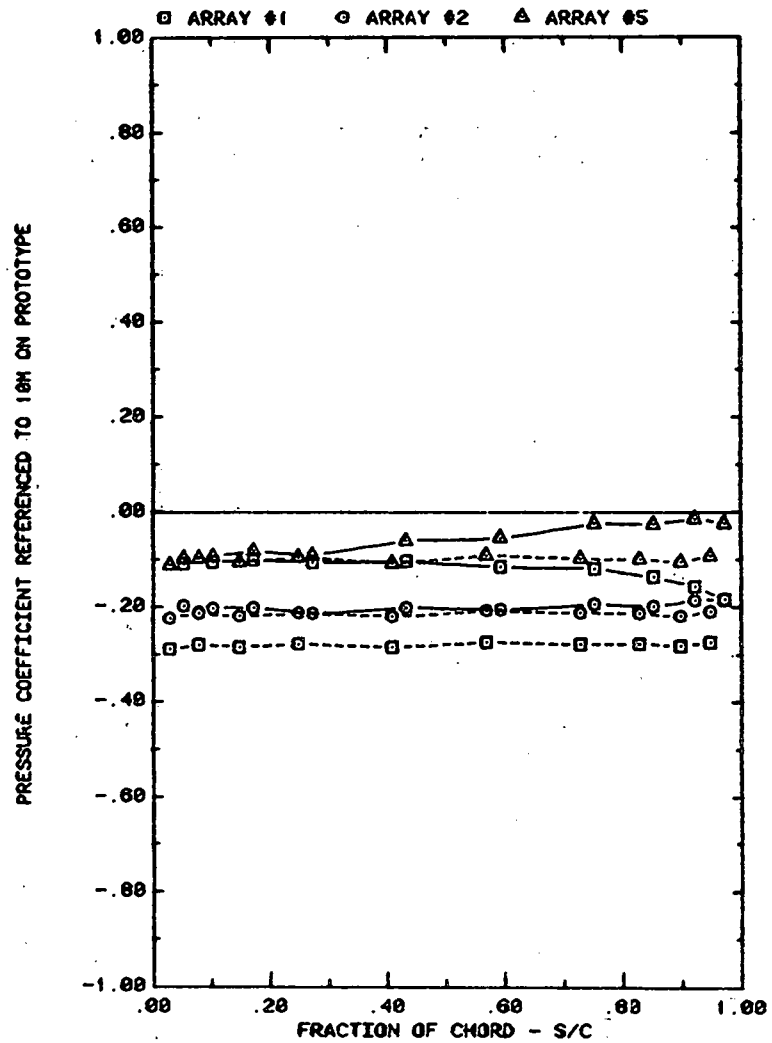

FRONT AND BACK PRESSURES ON ARRAYS #1, #2, #5 WITH SEPARATION = 2C
EFFECT OF ARRAY WITH ALPHA = 120, WIND = 0, HF = 4°

Plot 3-4. (Continued)

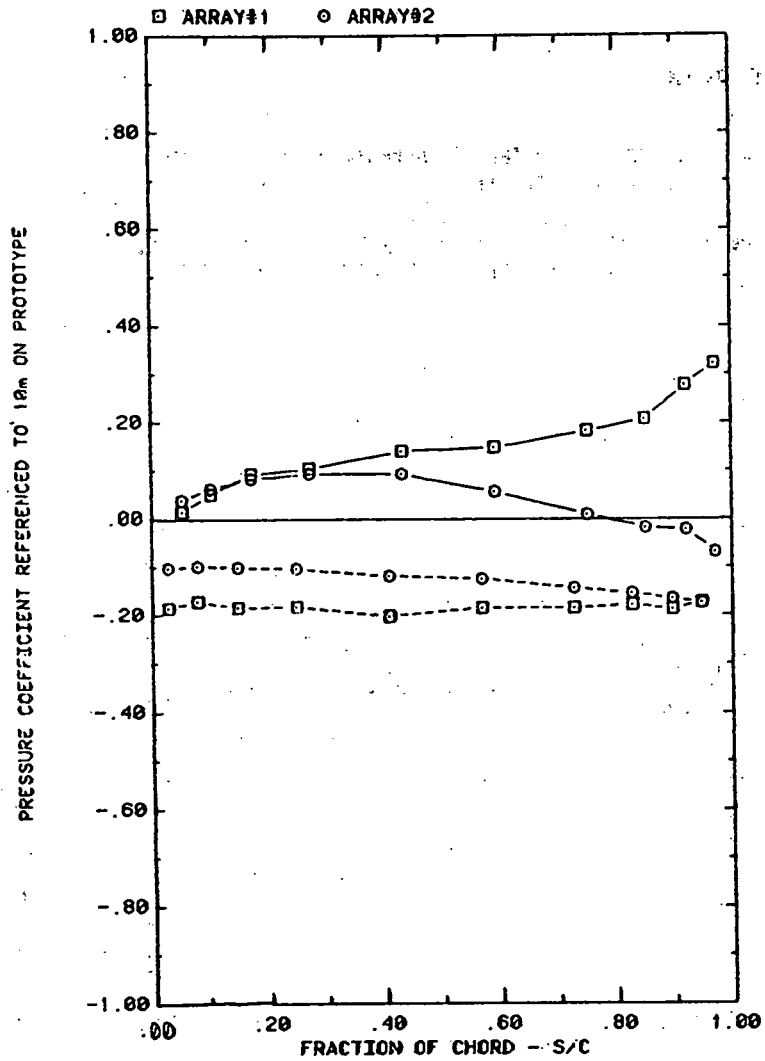

FRONT AND BACK PRESSURES ON ARRAYS #1 WITH SEPARATION = 2C
EFFECT OF ARRAY WITH ALPHA=35, H=1°, D=10°, AND P=30%

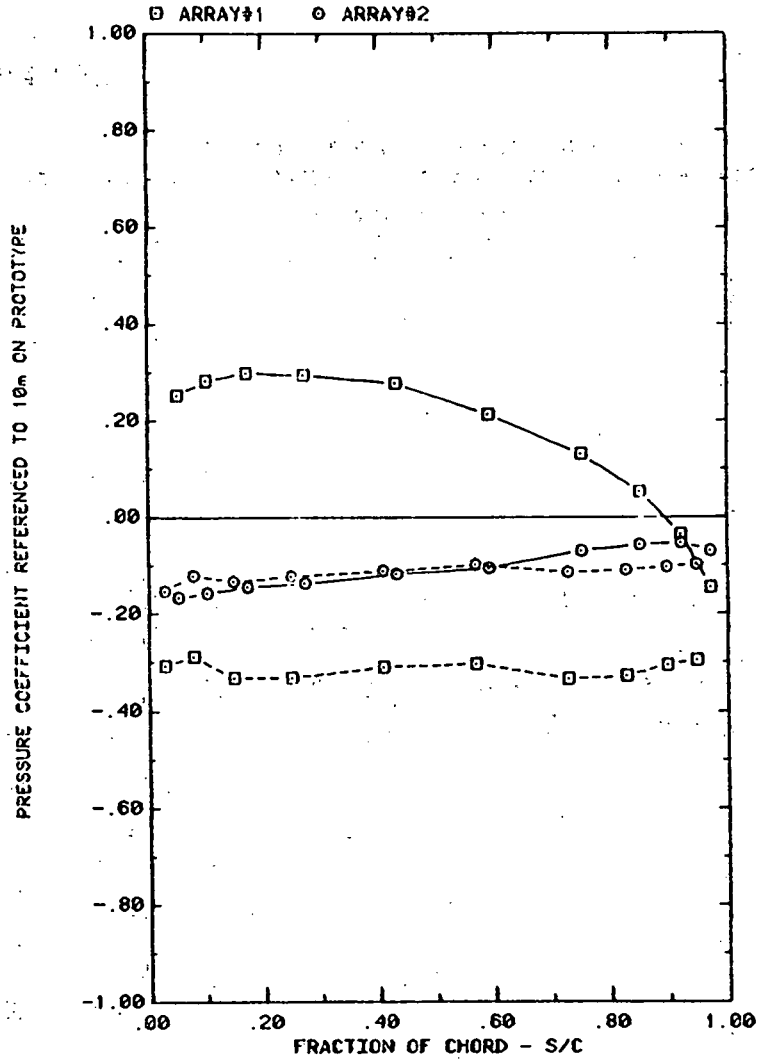

FRONT AND BACK PRESSURES ON ARRAYS #1 WITH SEPARATION = 2C
EFFECT OF ARRAY WITH ALPHA=145, H=1°, D=10°, AND P=30%

Plot 3-4. (Continued)

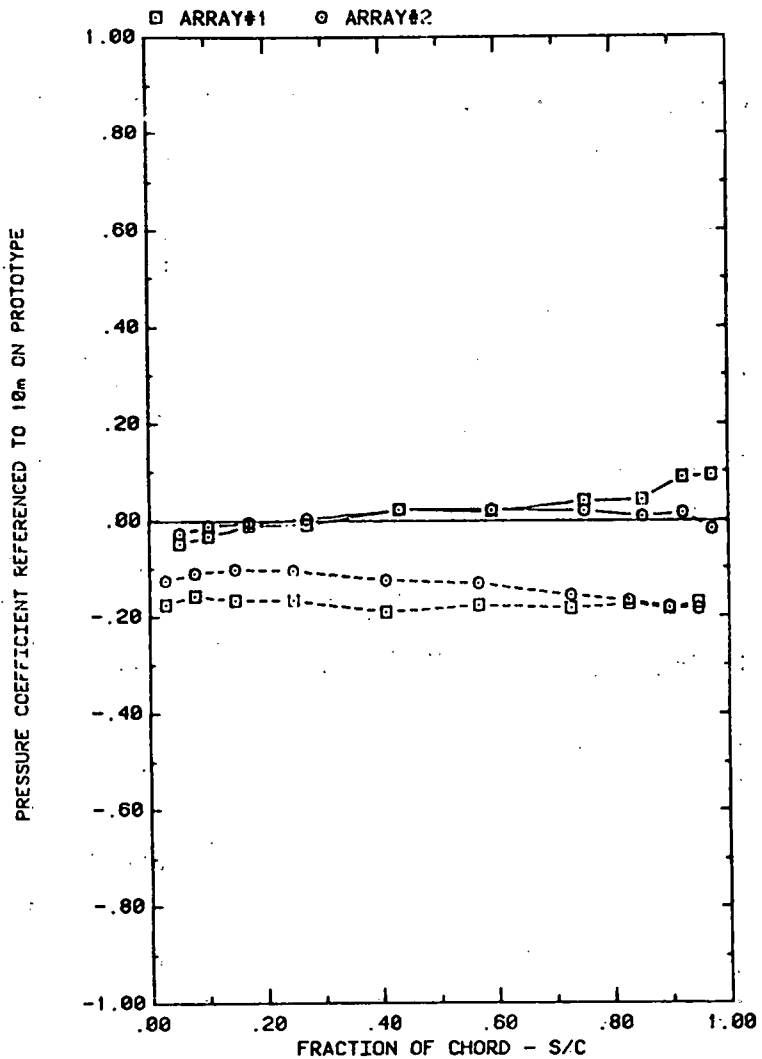

FRONT AND BACK PRESSURES ON ARRAYS #1 WITH SEPARATION = 2C
EFFECT OF ARRAY WITH ALPHA=35, H=2", D=10", AND P=30%

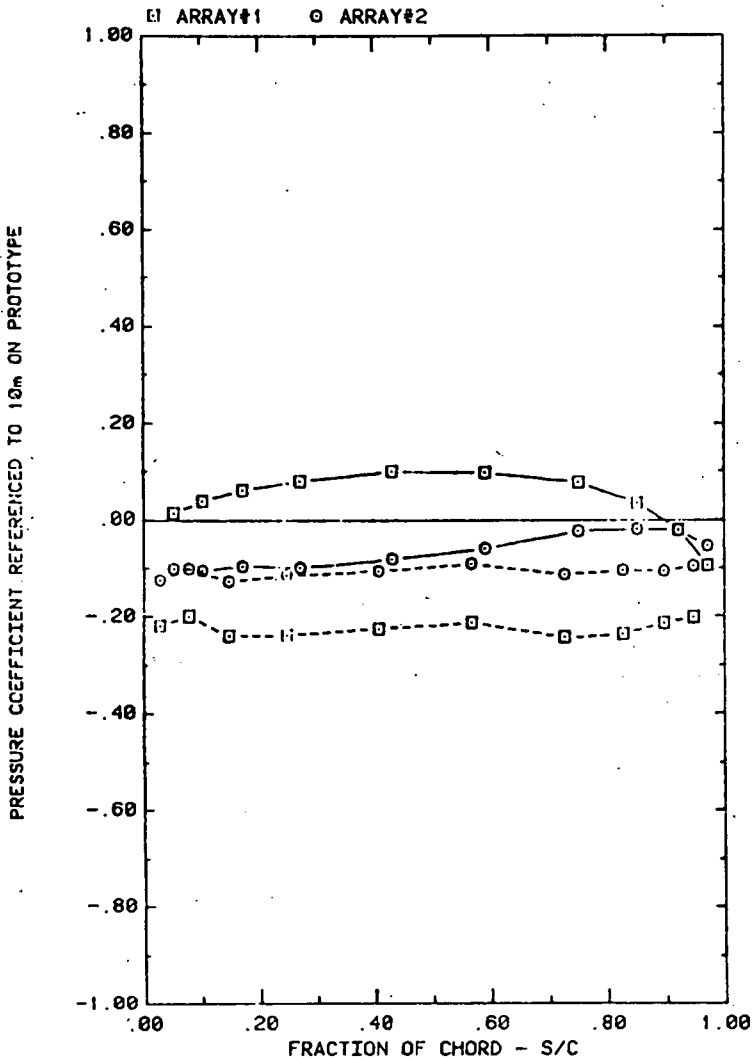

FRONT AND BACK PRESSURES ON ARRAYS #1 WITH SEPARATION = 2C
EFFECT OF ARRAY WITH ALPHA=145, H=2", D=10", AND P=30%

Plot 3-4. (Continued)

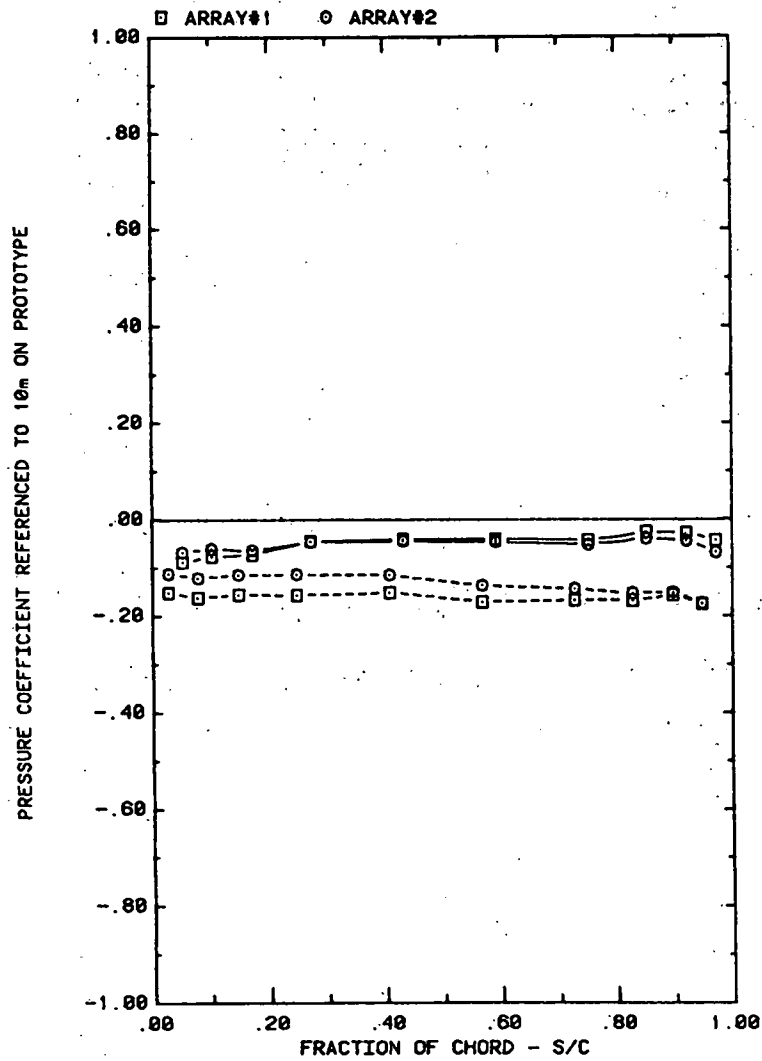

FRONT AND BACK PRESSURES ON ARRAYS #1 WITH SEPARATION = 2C
EFFECT OF ARRAY WITH ALPHA=35, H=3", D=10", AND P=30%

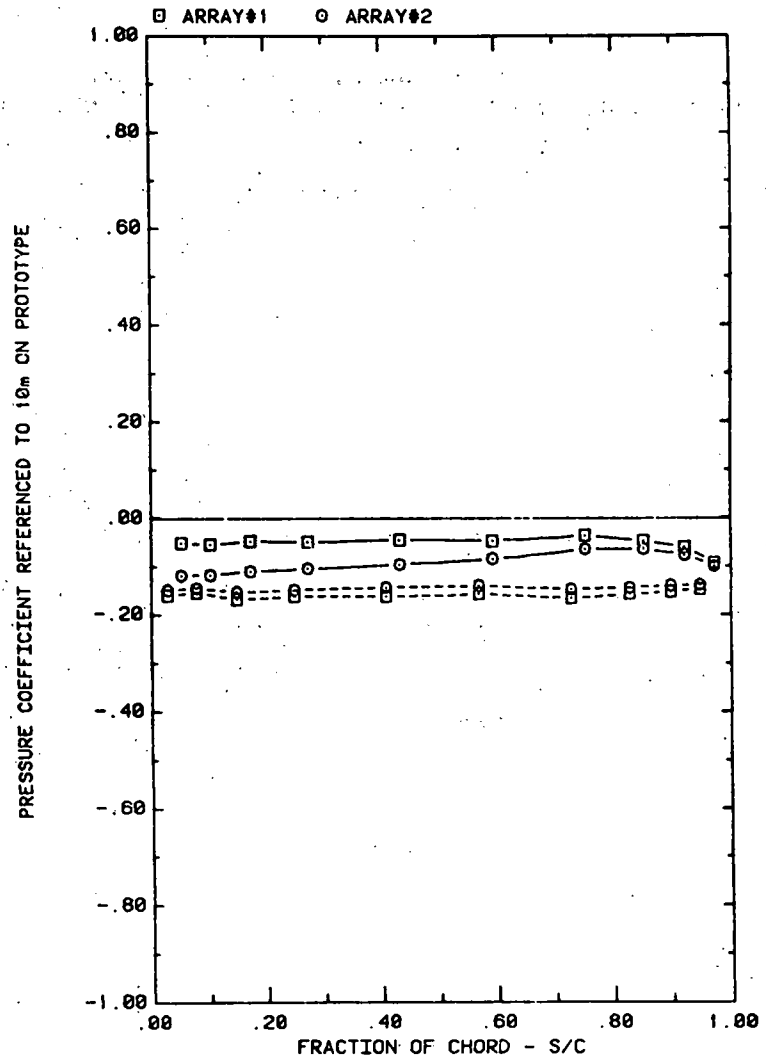

FRONT AND BACK PRESSURES ON ARRAYS #1 WITH SEPARATION = 2C
EFFECT OF ARRAY WITH ALPHA=145, H=3", D=10", AND P=30%

Plot 3-4. (Continued)

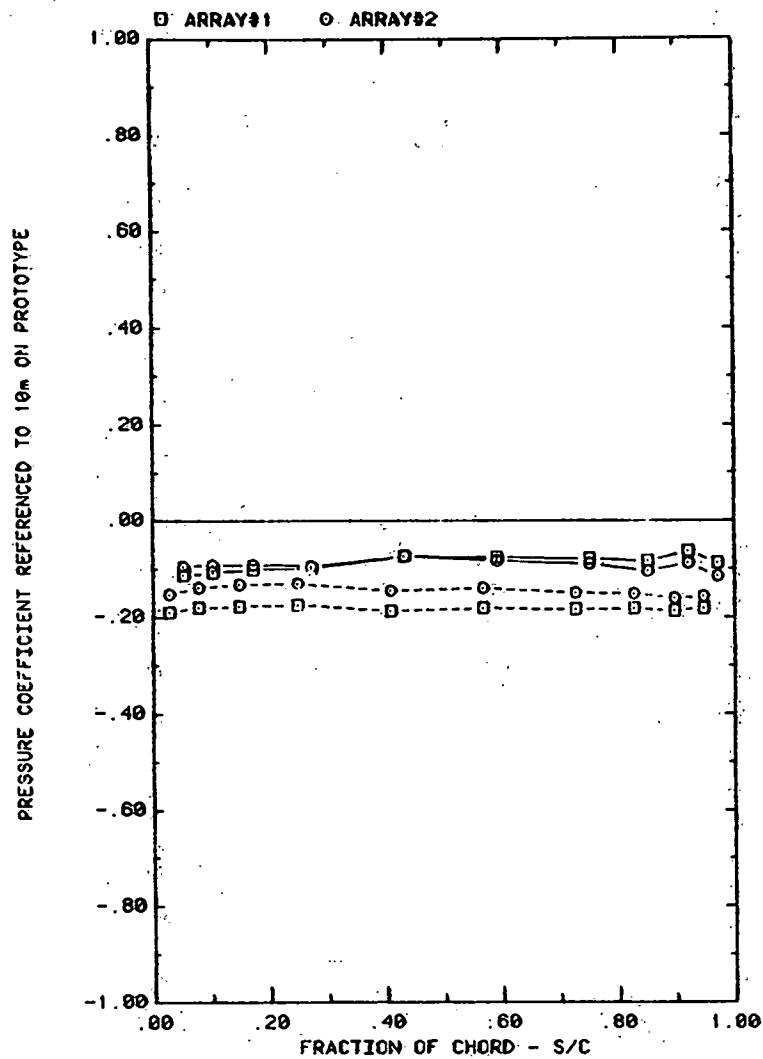

FRONT AND BACK PRESSURES ON ARRAYS #1 WITH SEPARATION = 2C
EFFECT OF ARRAY WITH $\alpha=35^\circ$, $H=4^\circ$, $D=10^\circ$, AND $P=30\%$

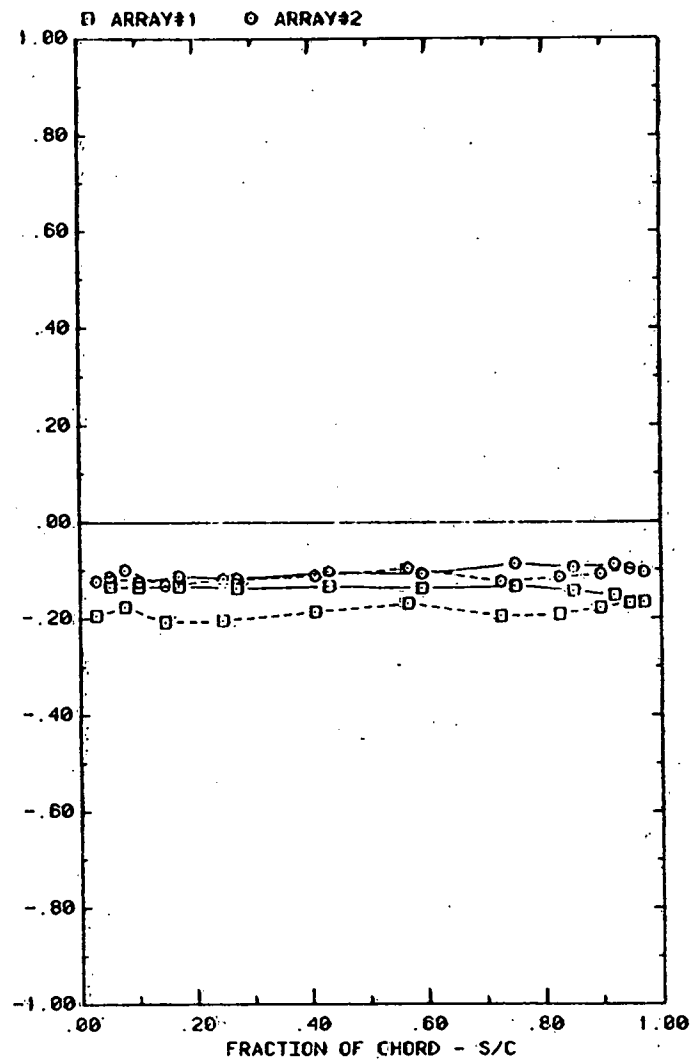

FRONT AND BACK PRESSURES ON ARRAYS #1 WITH SEPARATION = 2C
EFFECT OF ARRAY WITH $\alpha=145^\circ$, $H=4^\circ$, $D=10^\circ$, AND $P=30\%$

Plot 3-4. (Continued)

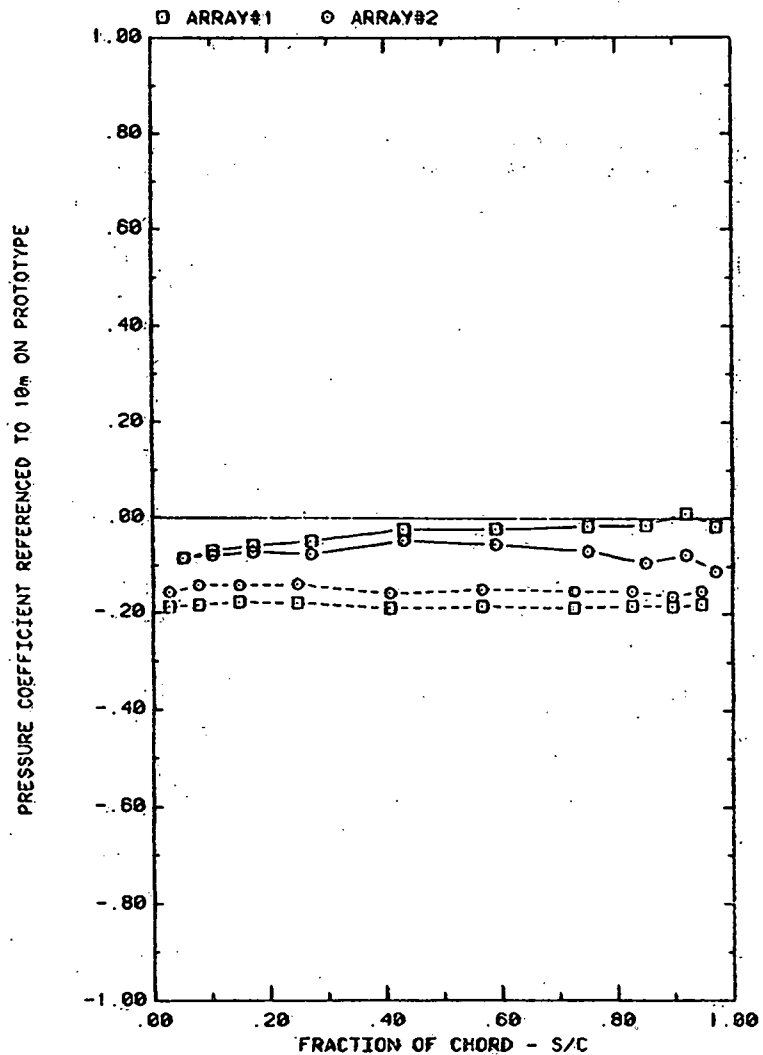

FRONT AND BACK PRESSURES ON ARRAYS #1&2 WITH SEPARATION = 2C
EFFECT OF ARRAY WITH ALPHA=35, H=5", D=10", AND P=30%

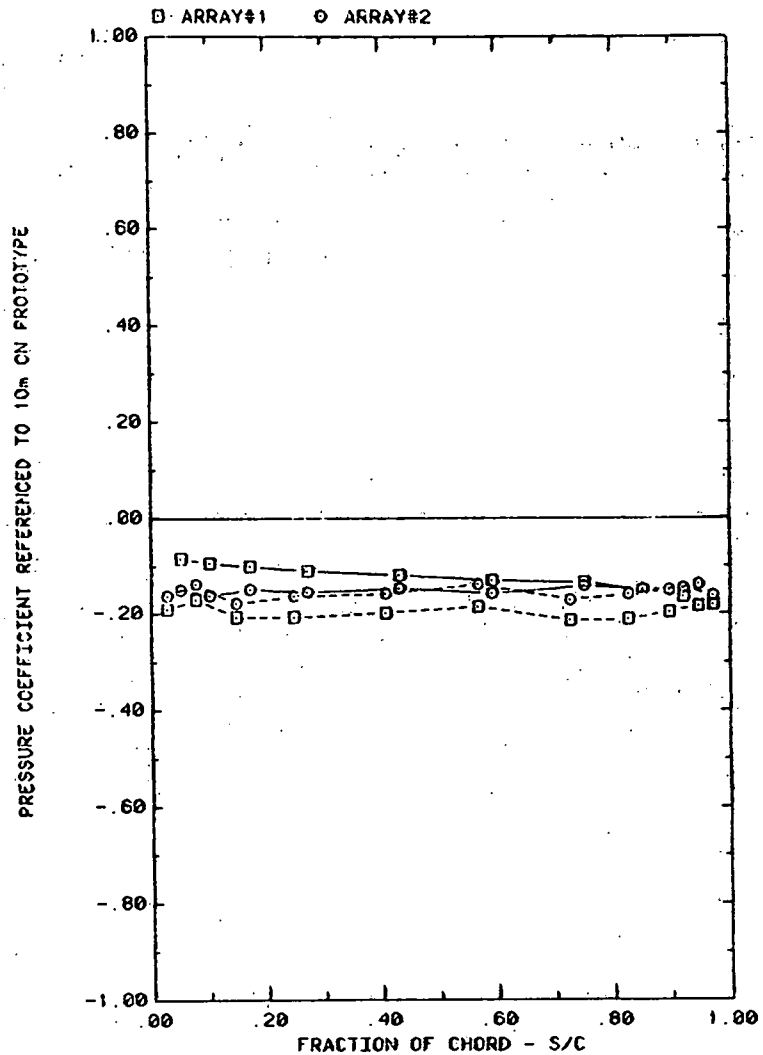

FRONT AND BACK PRESSURES ON ARRAYS #1&2 WITH SEPARATION = 2C
EFFECT OF ARRAY WITH ALPHA=45, H=5", D=10", AND P=30%

Plot 3-4. (Concluded)

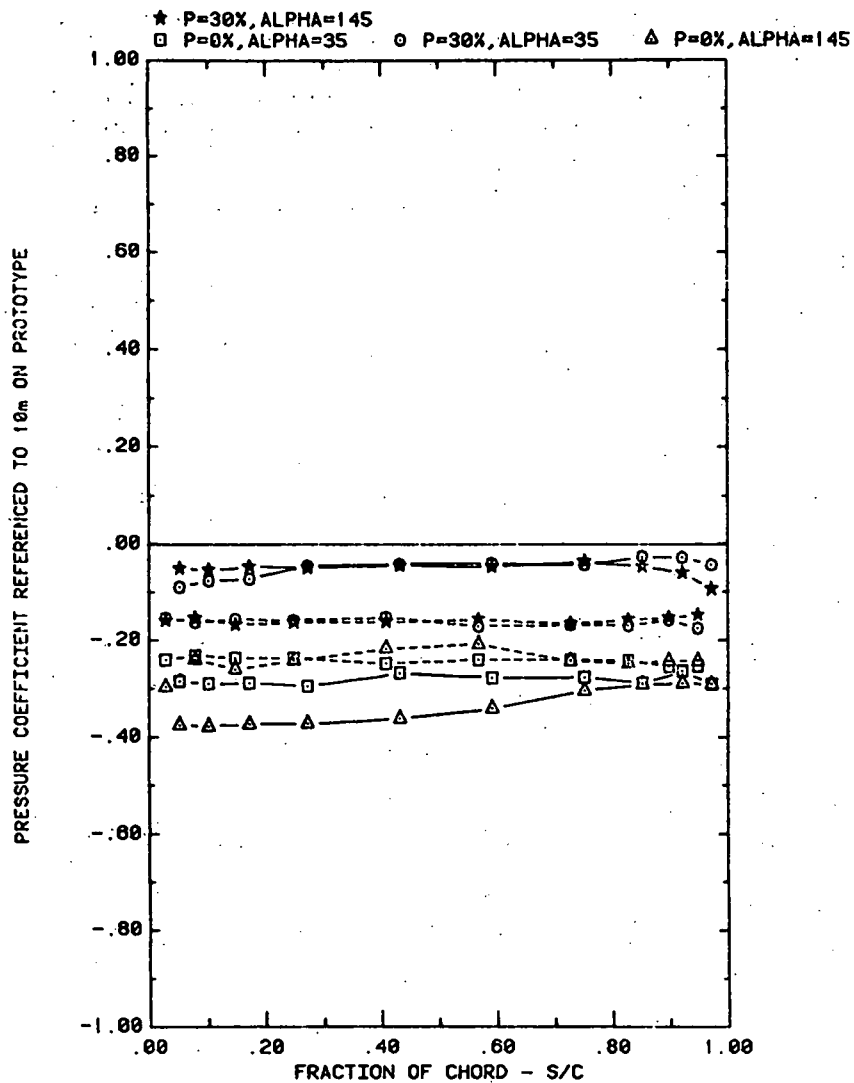

FRONT AND BACK PRESSURES ON ARRAY #1 WITH SEPARATION = 2C
 EFFECT OF FENCE POROSITY WITH ALPHA=35 OR 145, D=10°, AND H=3°

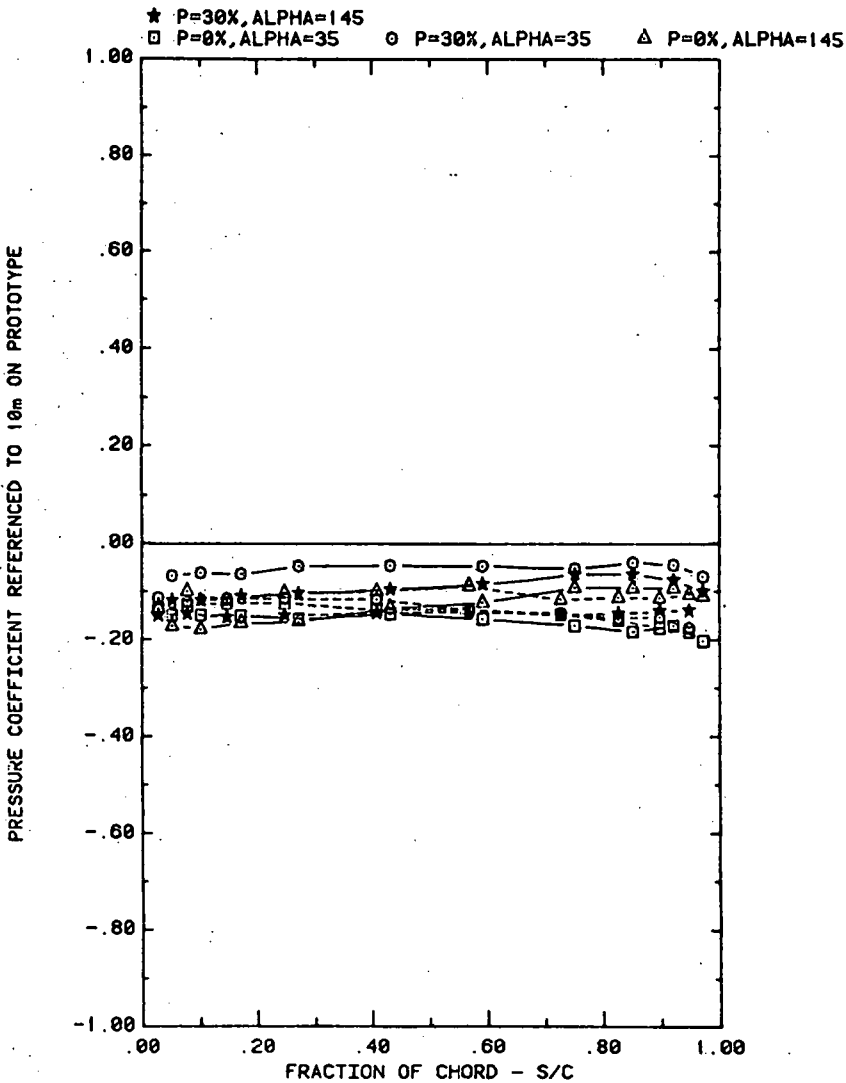

FRONT AND BACK PRESSURES ON ARRAY #2 WITH SEPARATION = 2C
 EFFECT OF FENCE POROSITY WITH ALPHA=35 OR 145, D=10°, AND H=3°

Plot 3-5. Multiple Arrays with Fence, WD = 0°
 Effect of Fence Porosity

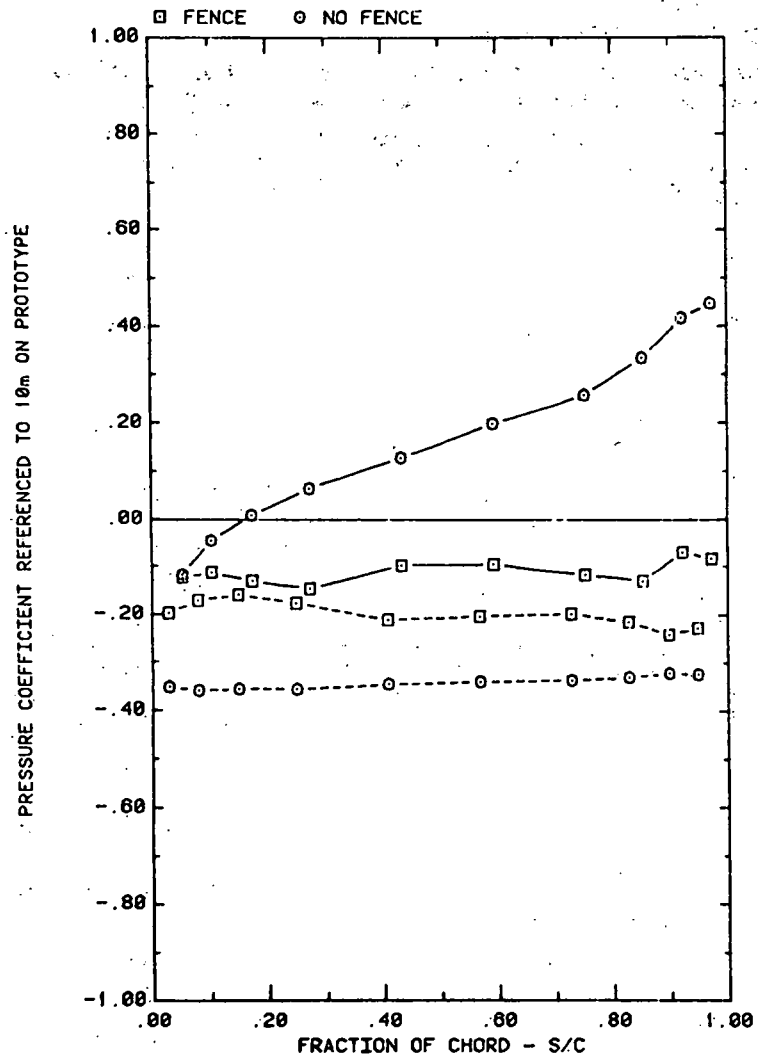

FRONT AND BACK PRESSURES ON ARRAY #1 WITH $X=2C$, AND $WIND=0$
EFFECT OF FENCE ON ARRAY EDGE; $\alpha=35^\circ$, $H=3^\circ$, $D=10^\circ$, AND $P=30\%$

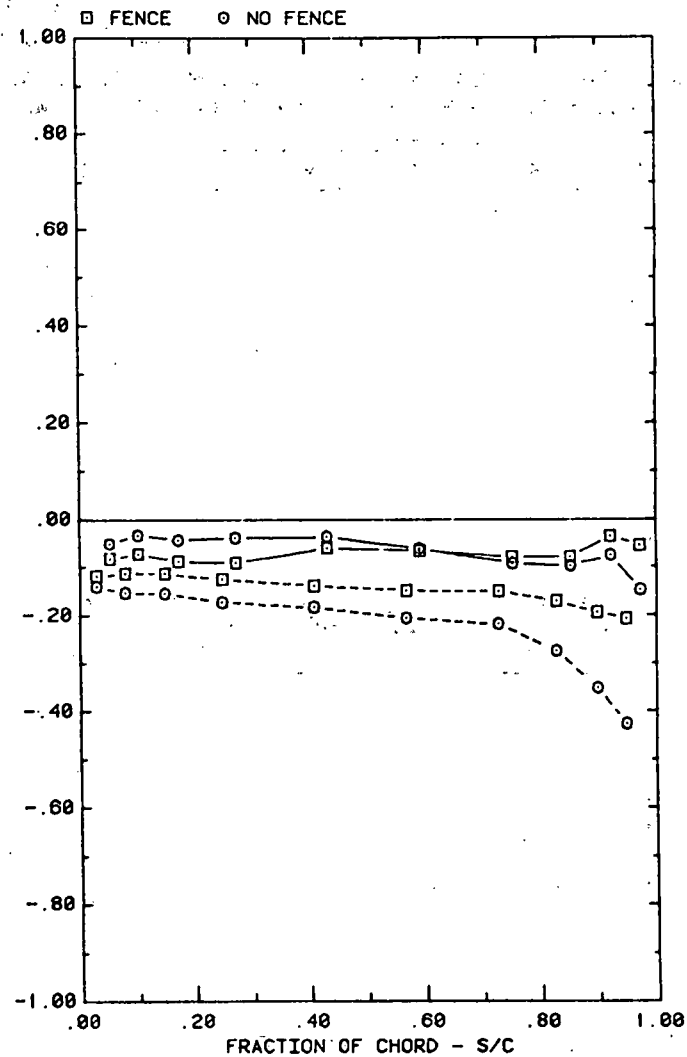

FRONT AND BACK PRESSURES ON ARRAY #2 WITH $X=2C$, AND $WIND=0$
EFFECT OF FENCE ON ARRAY EDGE; $\alpha=35^\circ$, $H=3^\circ$, $D=10^\circ$, AND $P=30\%$

Plot 4-1. Edge Study, $WD = 0^\circ$
Effect of Fence

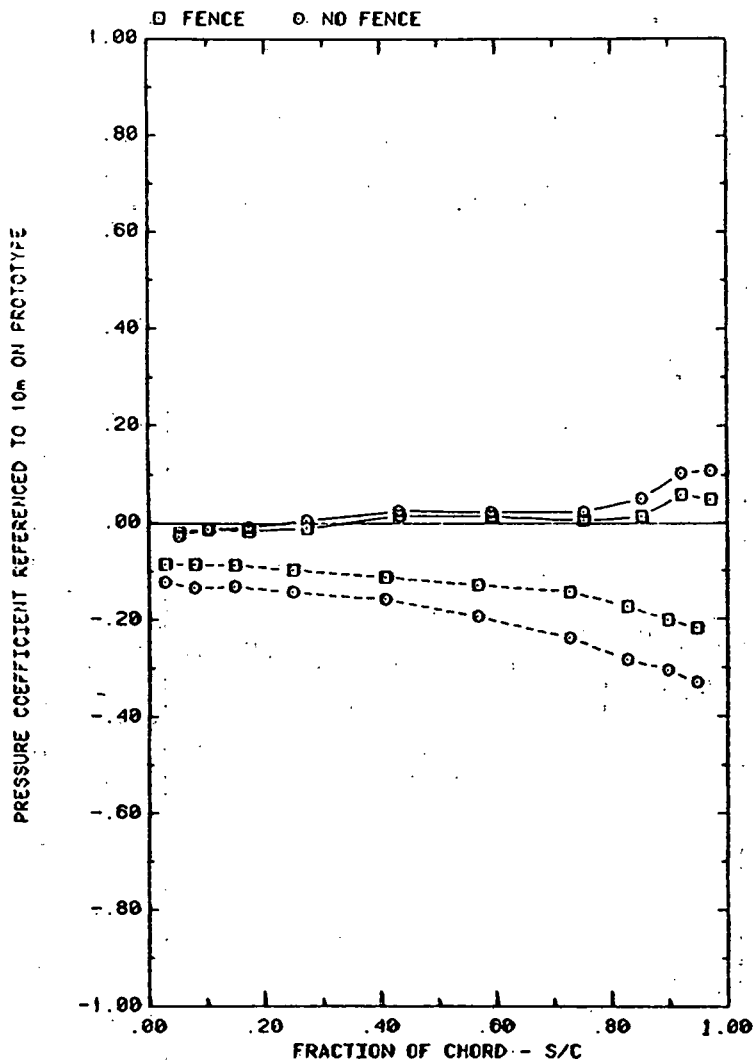

FRONT AND BACK PRESSURES ON ARRAY #5 WITH $X=2C$, AND WIND= 0°
EFFECT OF FENCE ON ARRAY EDGE; $\alpha=35^\circ$, $H=3^\circ$, $D=10^\circ$, AND $P=30\%$

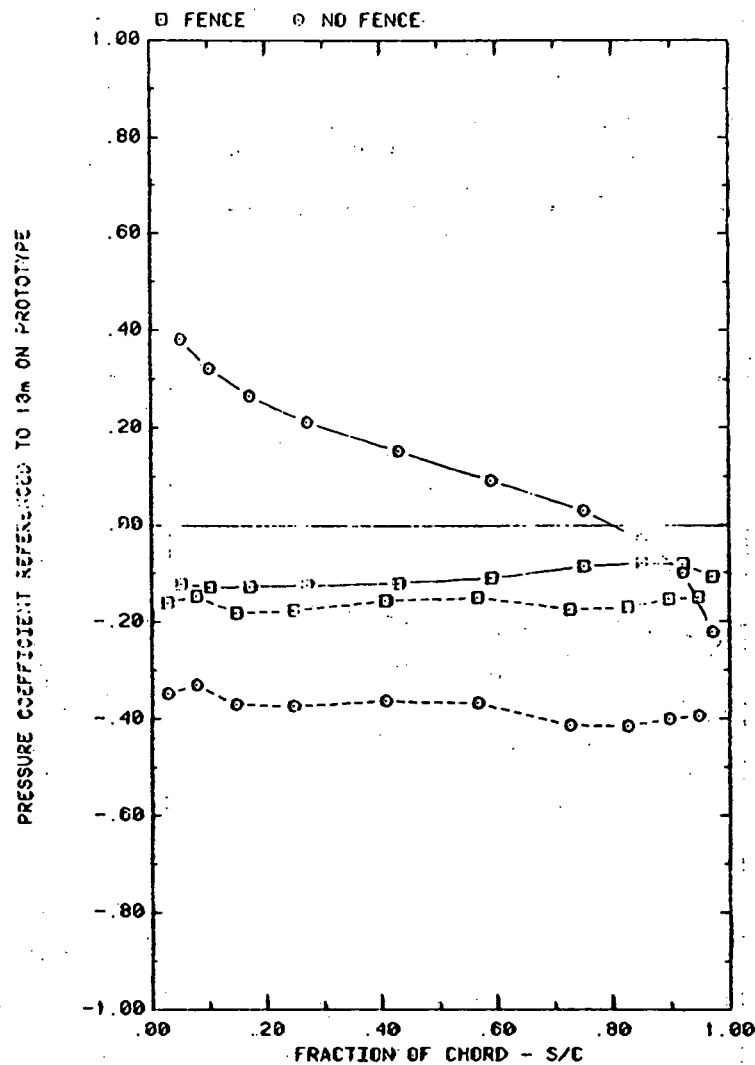

FRONT AND BACK PRESSURES ON ARRAY #1 WITH $X=2C$, AND WIND= 0°
EFFECT OF FENCE ON ARRAY EDGE; $\alpha=145^\circ$, $H=3^\circ$, $D=10^\circ$, AND $P=30\%$

Plot 4-1. (Continued)

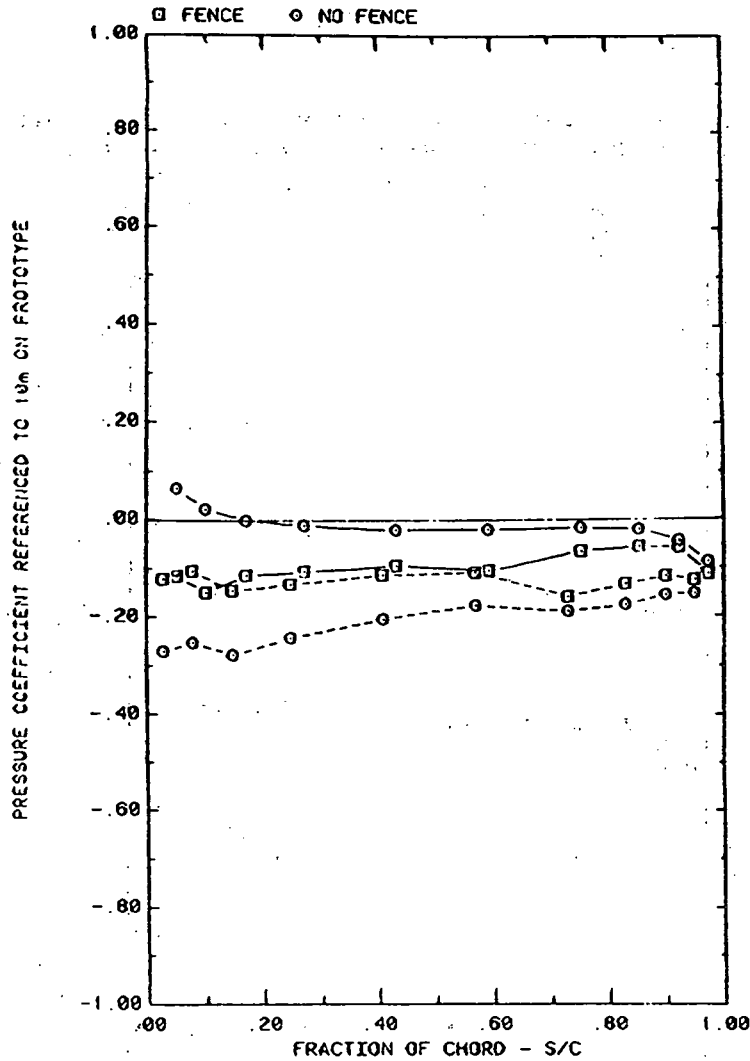

FRONT AND BACK PRESSURES ON ARRAY #2 WITH $X=2C$, AND WIND=0
EFFECT OF FENCE ON ARRAY EDGE; $\alpha=145^\circ$, $H=3^\circ$, $D=10^\circ$, AND $P=30\%$

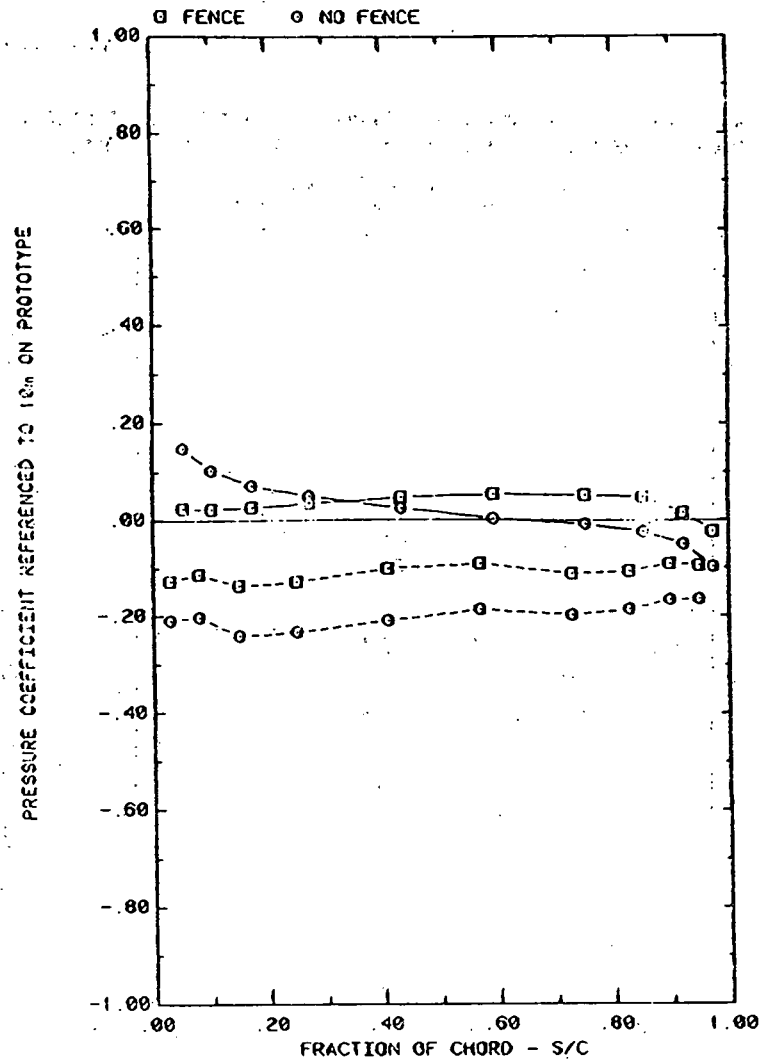

FRONT AND BACK PRESSURES ON ARRAY #5 WITH $X=2C$, AND WIND=0
EFFECT OF FENCE ON ARRAY EDGE; $\alpha=145^\circ$, $H=3^\circ$, $D=10^\circ$, AND $P=30\%$

Plot 4-1. (Concluded)

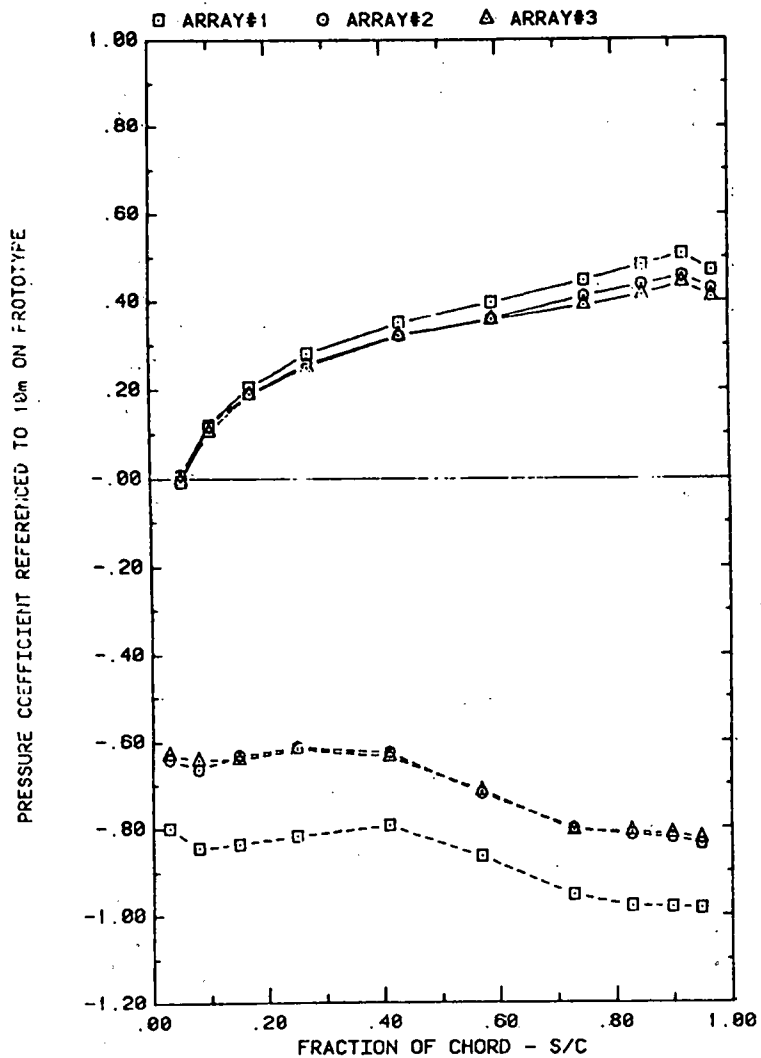

FRONT AND BACK PRESSURES 0.6" IN FROM ARRAY EDGE; X=2C, WIND=45
EFFECT OF ARRAY WITH ALPHA=35, FC=0, H=3°, D=10°, AND P=30%

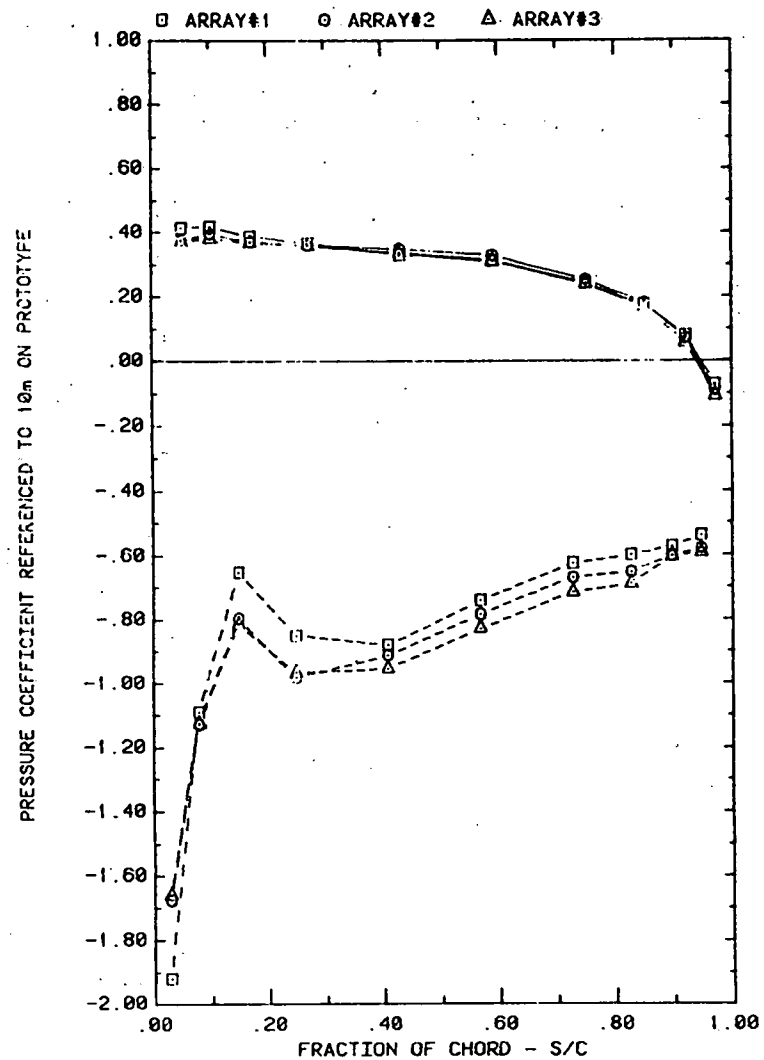

FRONT AND BACK PRESSURES 0.6" IN FROM ARRAY EDGE; X=2C, WIND=45
EFFECT OF ARRAY WITH ALPHA=145, FC=0, H=3°, D=10°, AND P=30%

Plot 5-1-1. Corner Study, WD = 45°, Standard Model
Effect of Array Position

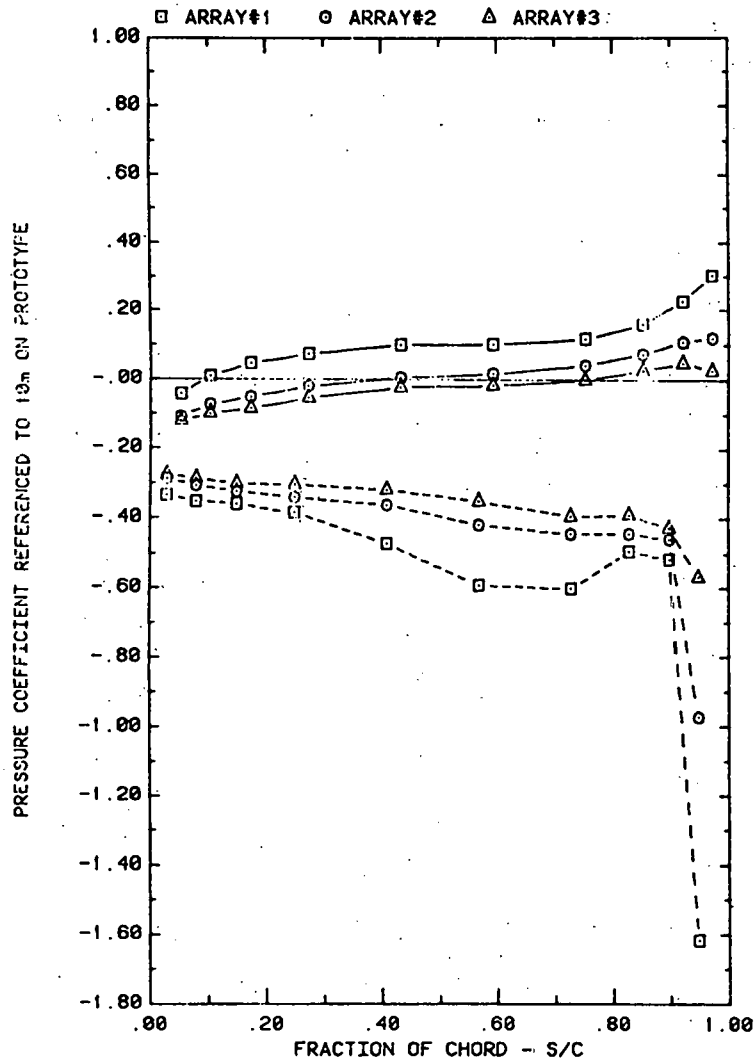

FRONT AND BACK PRESSURES 0.6° IN FROM ARRAY EDGE; X=2C, WIND=45
EFFECT OF ARRAY WITH ALPHA=35, FC=1, H=3°, D=10°, AND P=30%

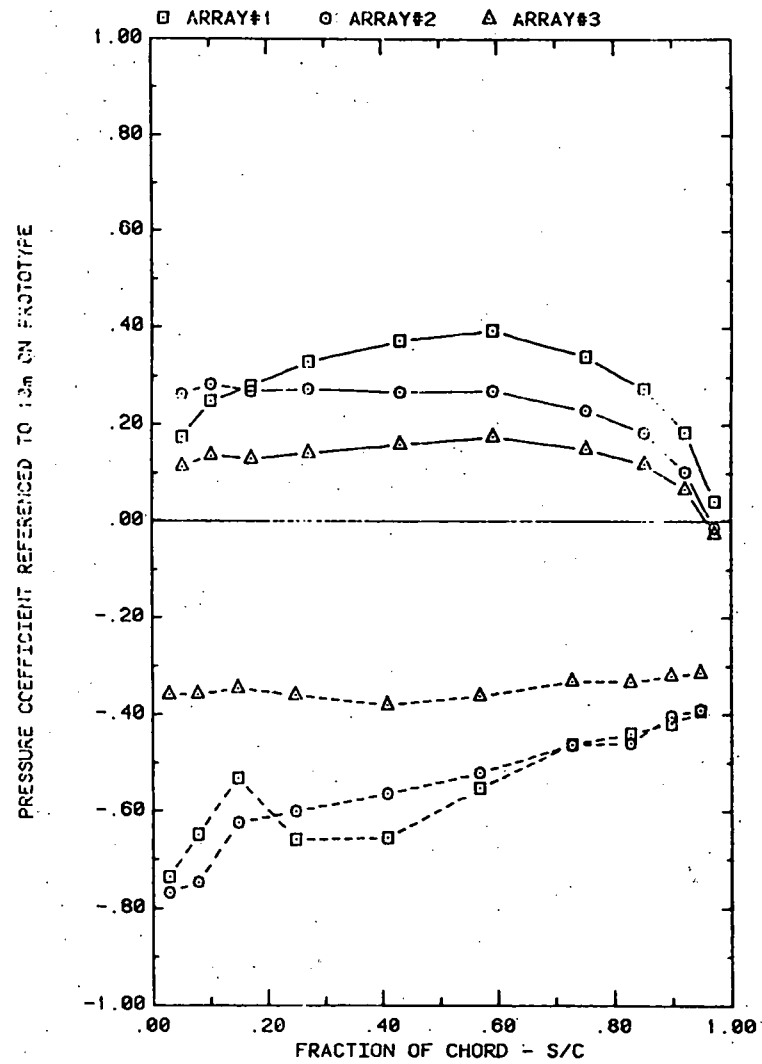

FRONT AND BACK PRESSURES 0.6° IN FROM ARRAY EDGE; X=2C, WIND=45
EFFECT OF ARRAY WITH ALPHA=145, FC=1, H=3°, D=10°, AND P=30%

Plot 5-1-1. (Continued)

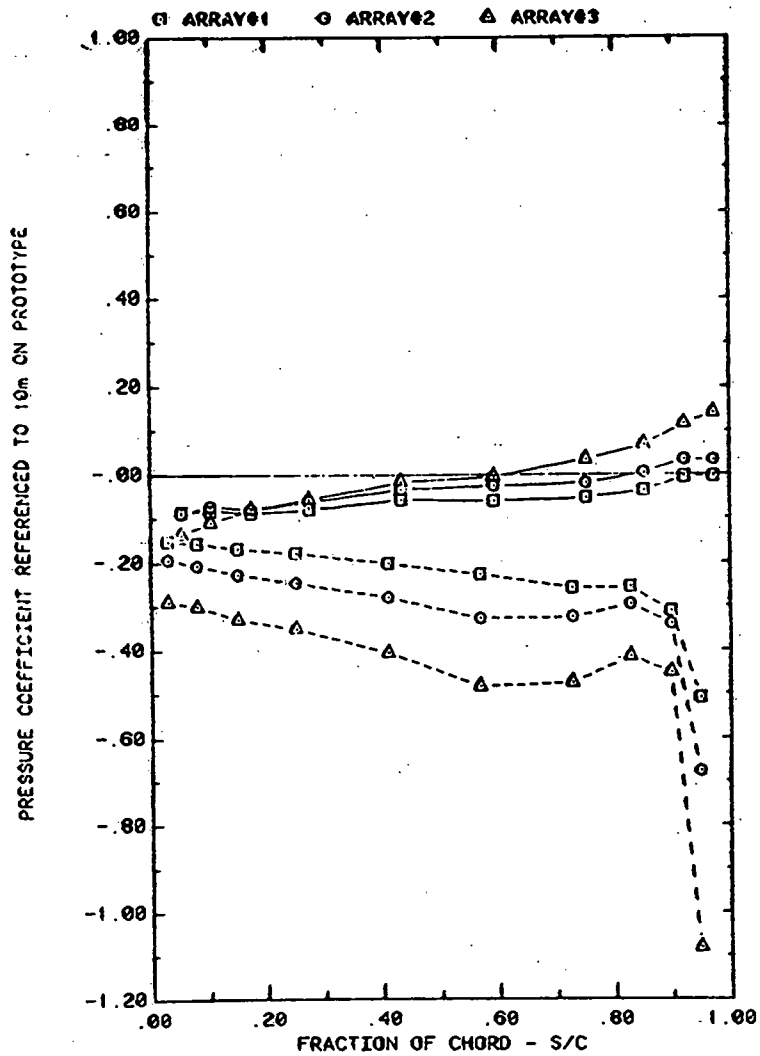

FRONT AND BACK PRESSURES 0.6° IN FROM ARRAY EDGE; X=2C, WIND=45
EFFECT OF ARRAY WITH ALPHA=35, FC=2, H=3°, D=10°, AND P=30%

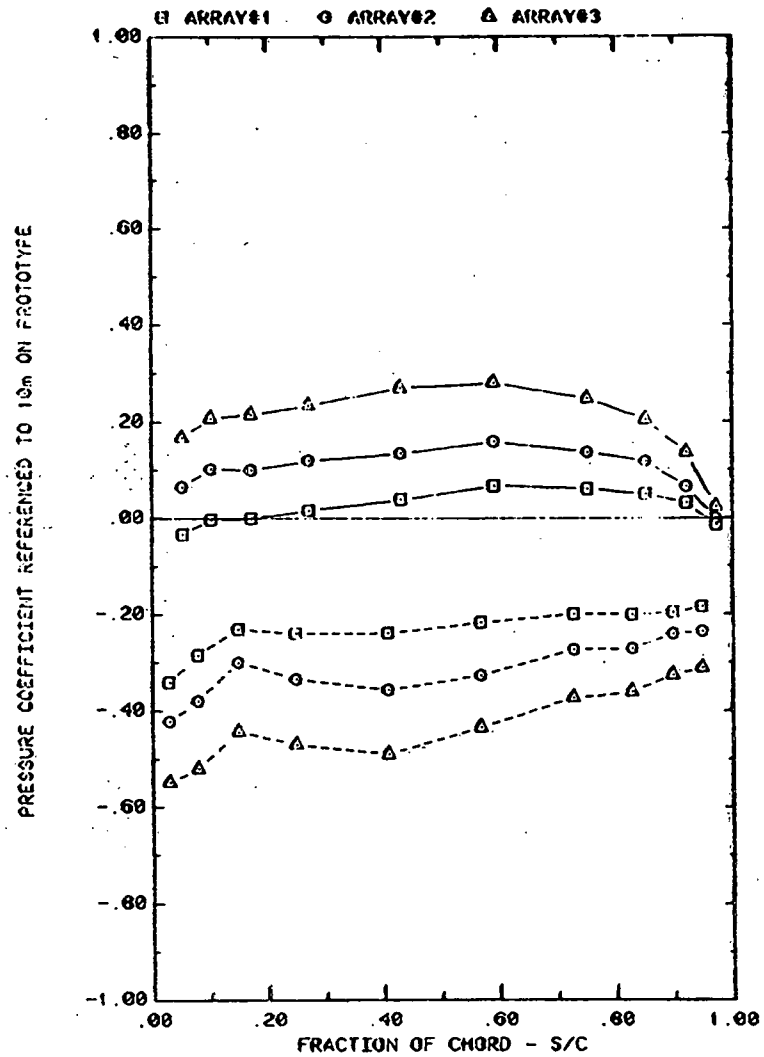

FRONT AND BACK PRESSURES 0.6° IN FROM ARRAY EDGE; X=2C, WIND=45
EFFECT OF ARRAY WITH ALPHA=145, FC=2, H=3°, D=10°, AND P=30%

Plot 5-1-1. (Continued)

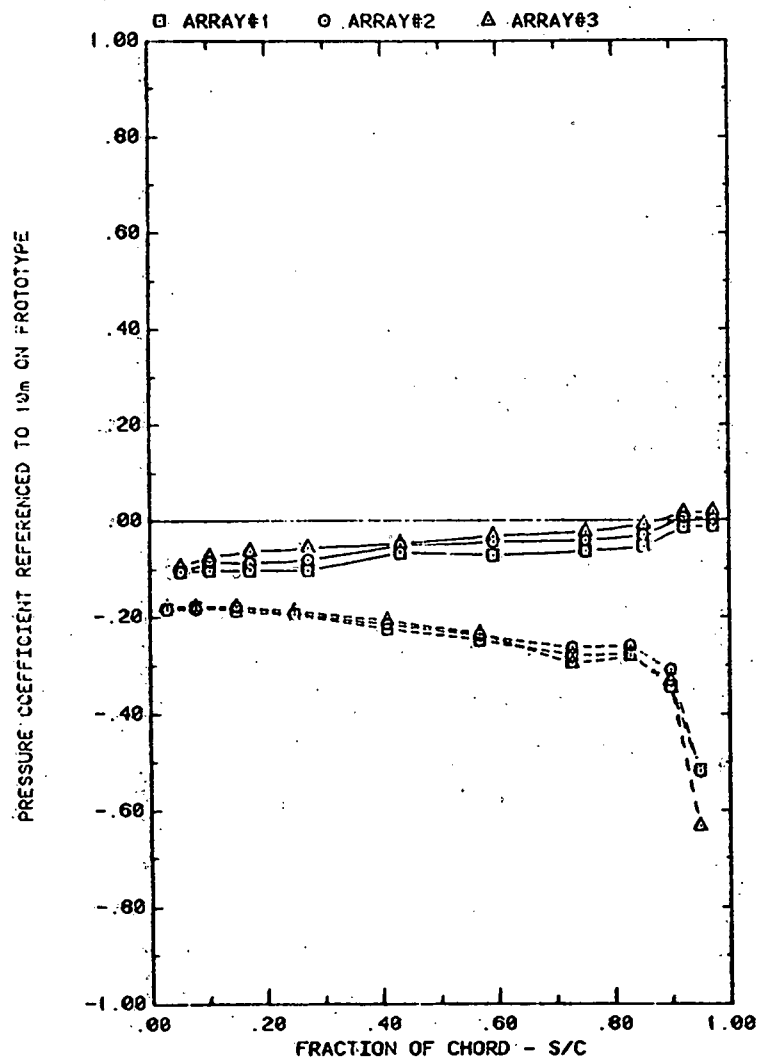

FRONT AND BACK PRESSURES 0.6" IN FROM ARRAY EDGE; X=2C, WIND=45
EFFECT OF ARRAY WITH ALPHA=35, FC=3, H=3°, D=10°, AND P=30%

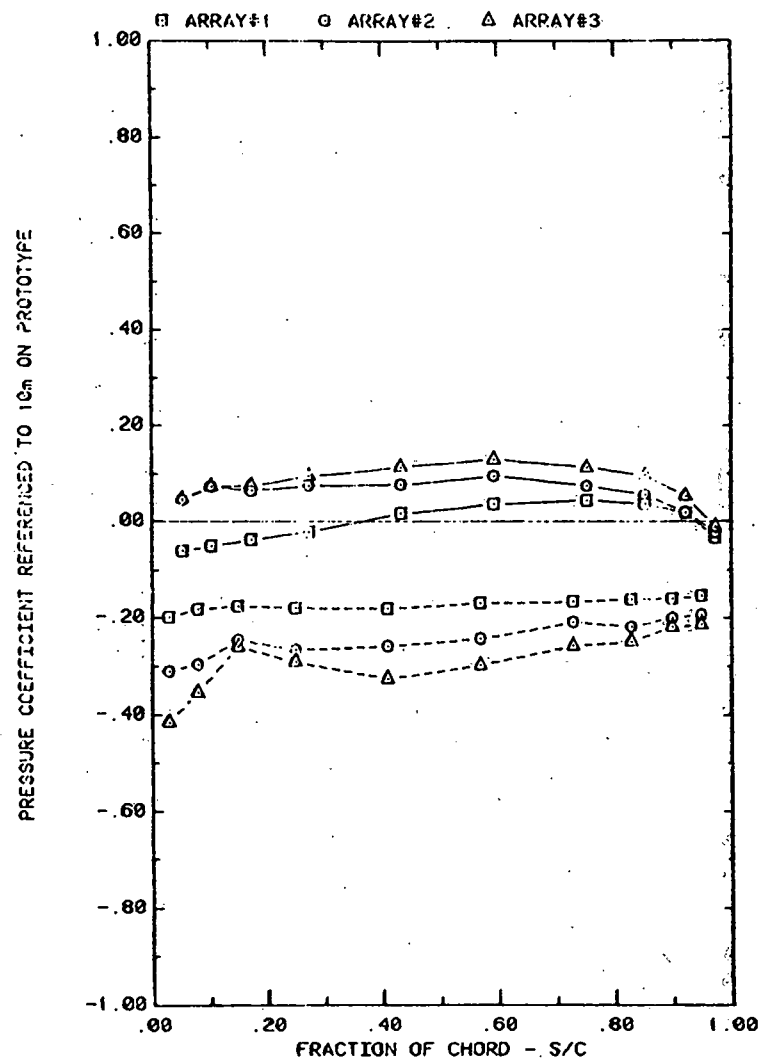

FRONT AND BACK PRESSURES 0.6" IN FROM ARRAY EDGE; X=2C, WIND=45
EFFECT OF ARRAY WITH ALPHA=145, FC=3, H=3°, D=10°, AND P=30%

Plot 5-1-1. (Continued)

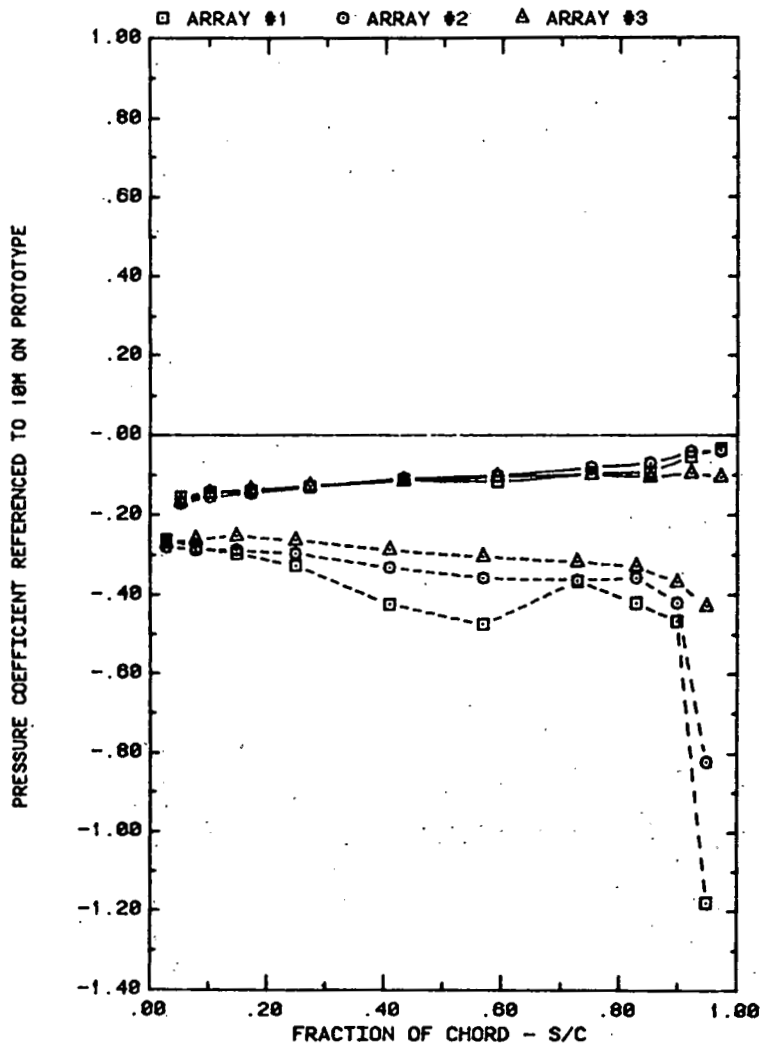

FRONT AND BACK PRESSURES ON ARRAYS #1,2&3, WIND = 45
EFFECT OF ARRAY WITH ALPHA = 35, X = 2C, FC = 4

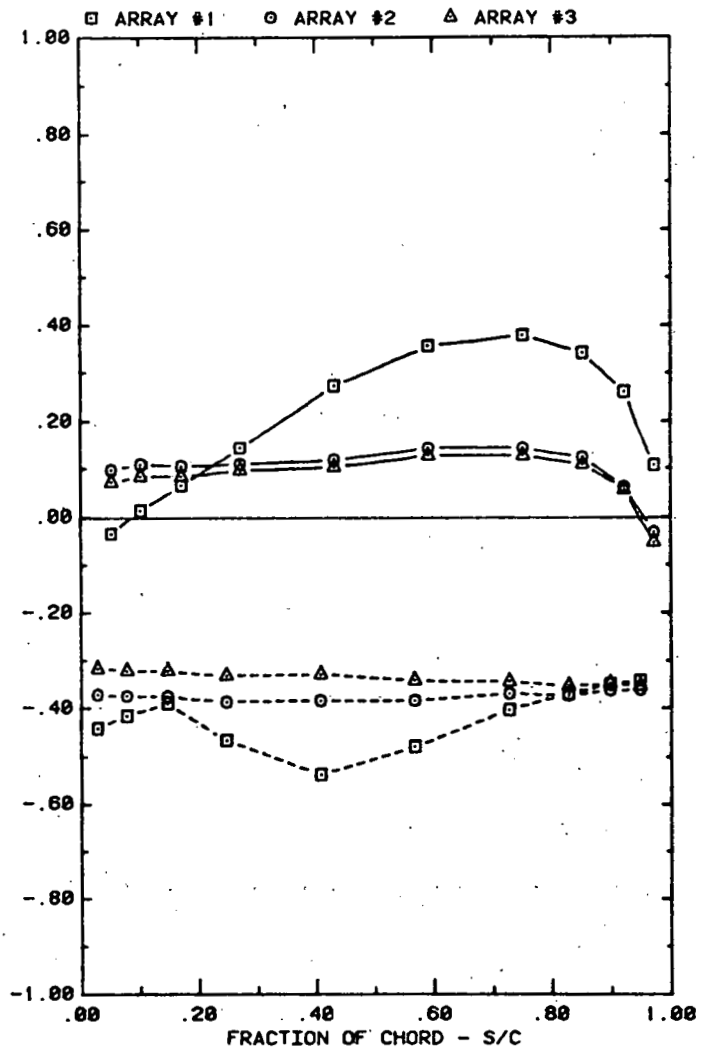

FRONT AND BACK PRESSURES ON ARRAYS #1,2&3, WIND = 45
EFFECT OF ARRAY WITH ALPHA = 145, X = 2C, FC = 4

Plot 5-1-1. (Concluded)

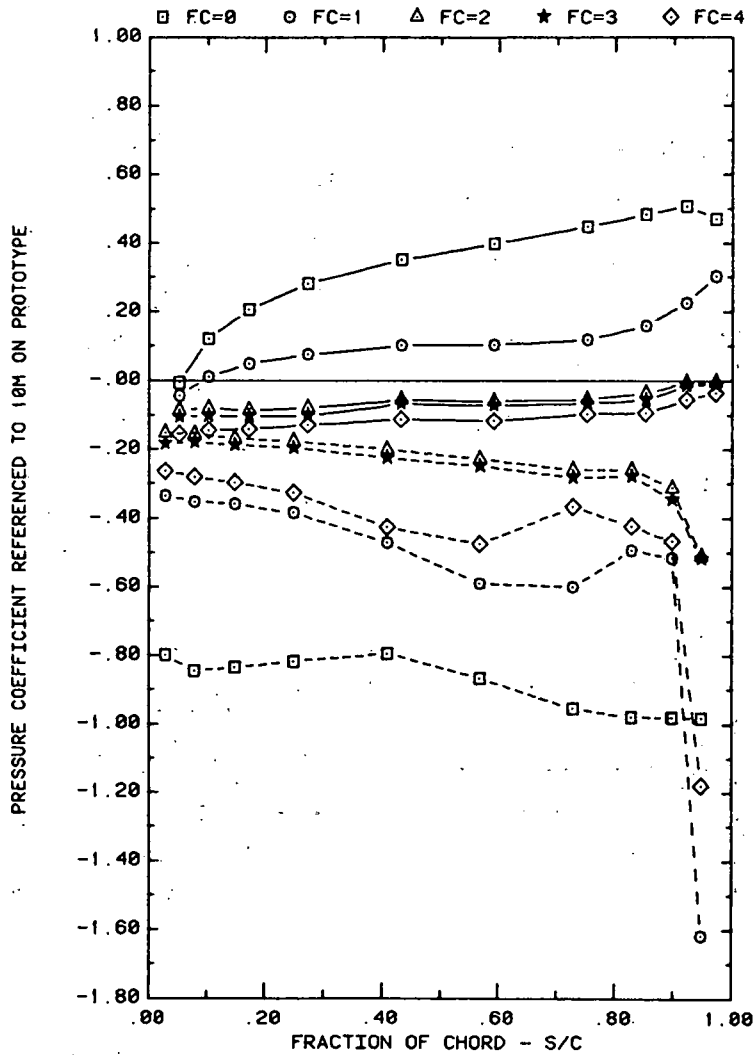

FRONT AND BACK PRESSURES 0.6" IN FROM EDGE OF ARRAY#1; WIND = 45
EFFECT OF FC WITH ALPHA=35, H=3", D=10", P=30%, AND X=2C

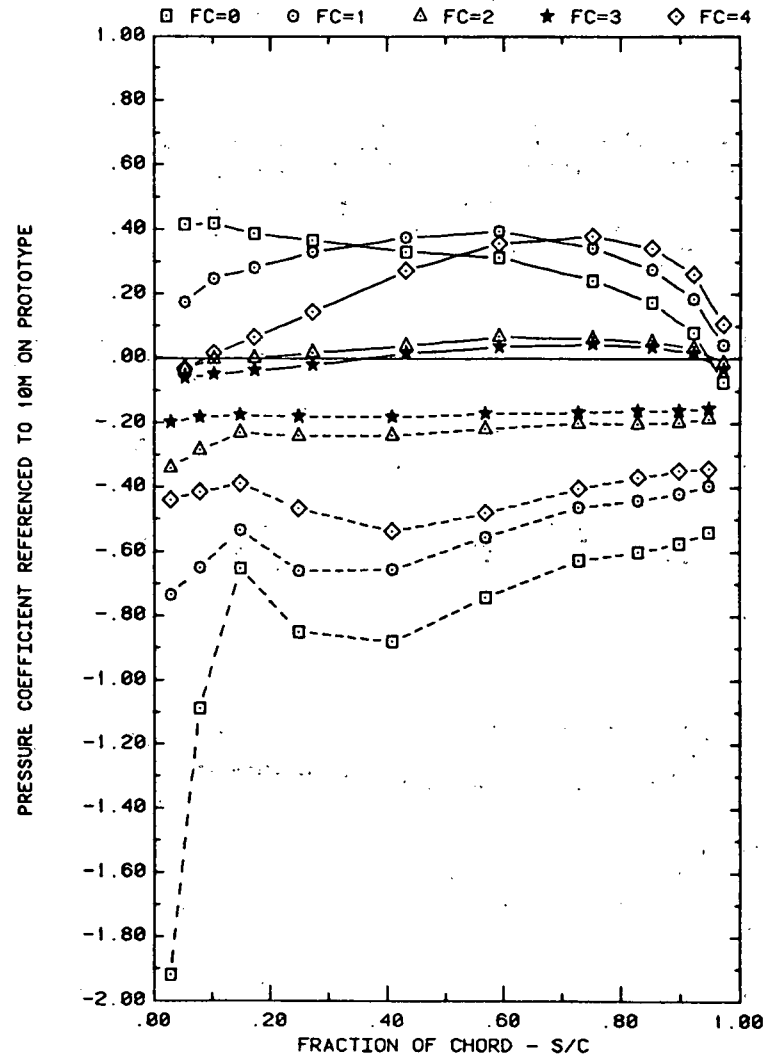

FRONT AND BACK PRESSURES 0.6" IN FROM EDGE OF ARRAY#1; WIND=45
EFFECT OF FC WITH ALPHA=145, H=3", D=10", P=30% AND X=2C

Plot 5-1-2. Corner Study, WD = 45°, Standard Model
Effect of Fence Configuration

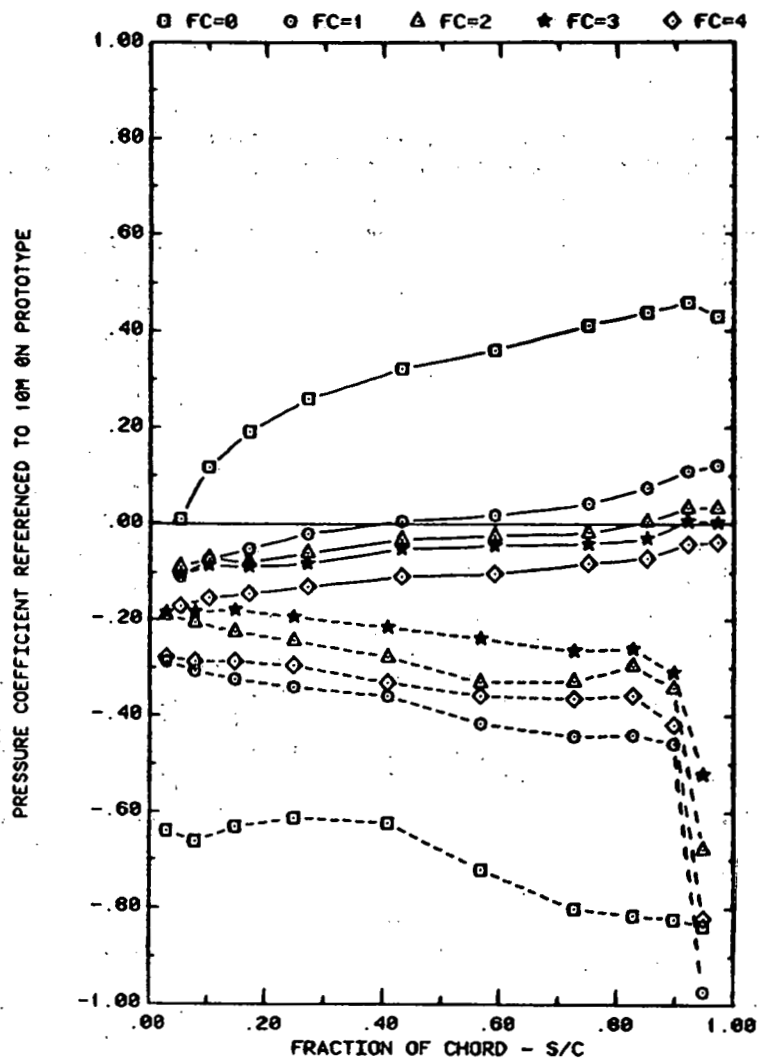

FRONT AND BACK PRESSURES 0.6° IN FROM EDGE OF ARRAY#2; WIND=45
EFFECT OF FC WITH ALPHA=35, H=3°, D=10°, P=30% AND X=2C

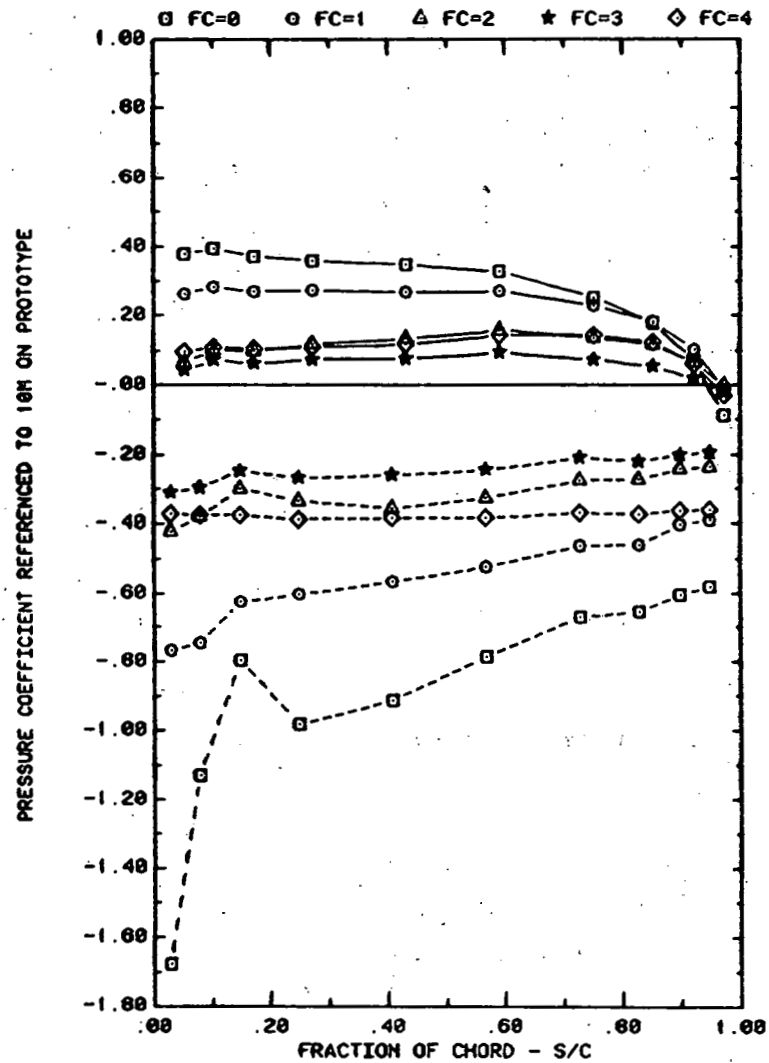

FRONT AND BACK PRESSURES 0.6° IN FROM EDGE OF ARRAY#2; WIND=45
EFFECT OF FC WITH ALPHA=145, H=3°, D=10°, P=30% AND X=2C

Plot 5-1-2. (Continued)

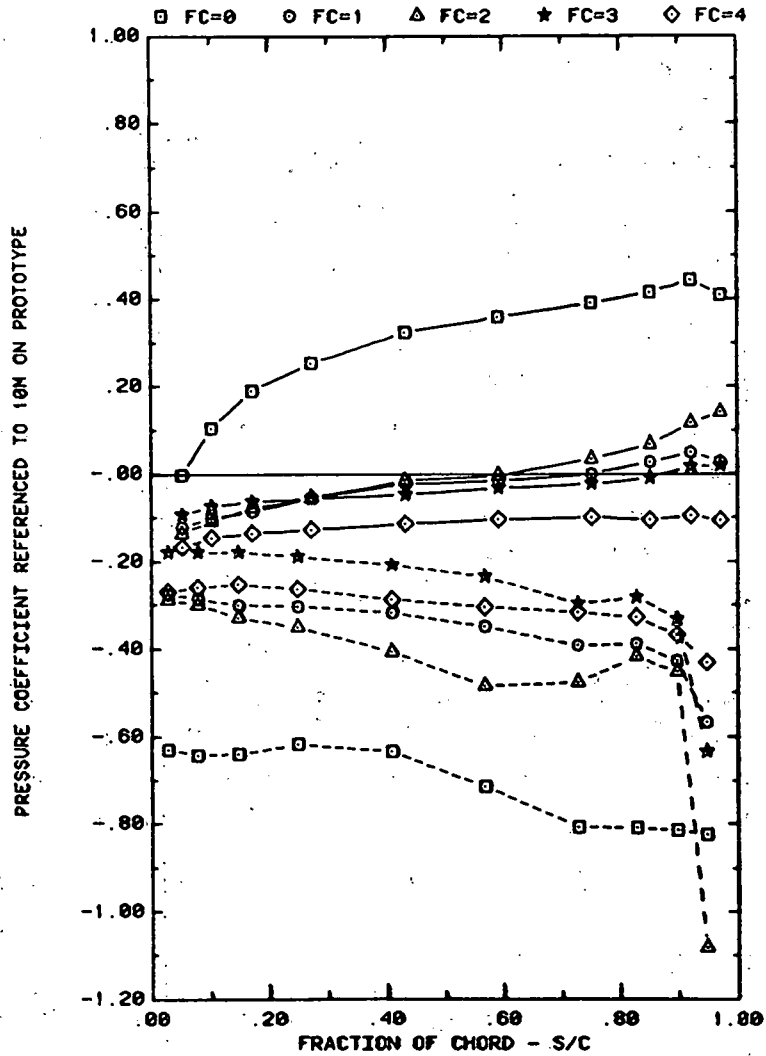

FRONT AND BACK PRESSURES 0.6° IN FROM EDGE OF ARRAY#3; WIND=45
EFFECT OF FC WITH ALPHA=35, H=3°, D=10°, P=30%, AND X=2C

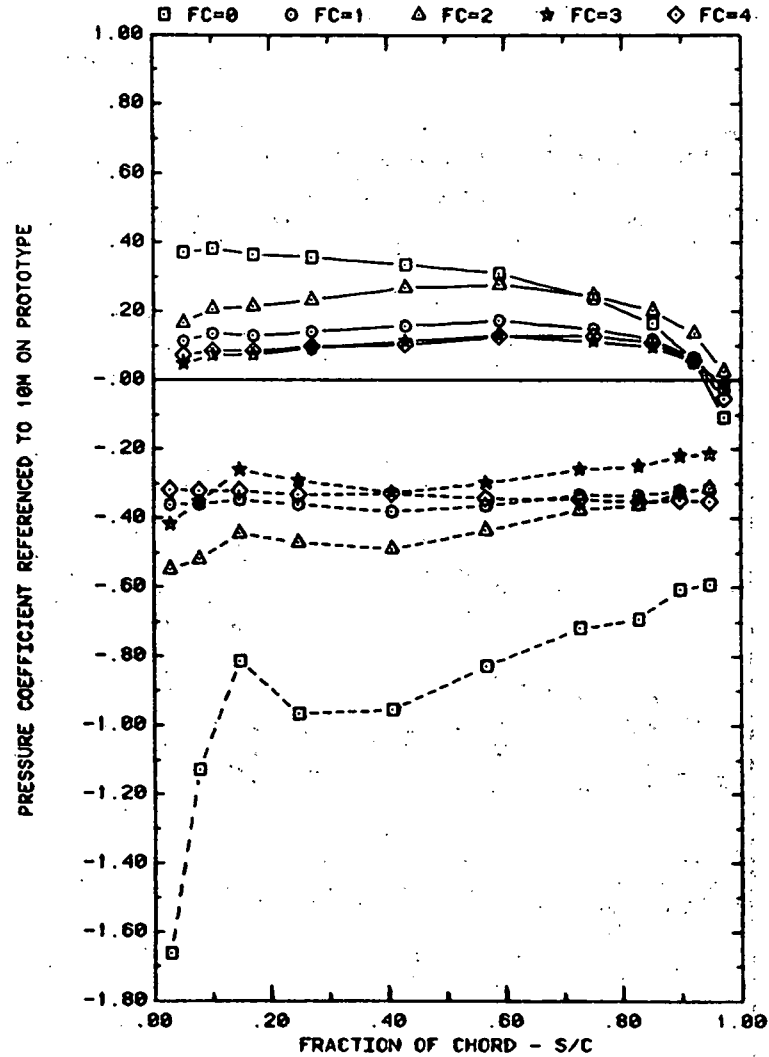

FRONT AND BACK PRESSURES 0.6° IN FROM EDGE OF ARRAY#3; WIND=45
EFFECT OF FC WITH ALPHA=145, H=3°, D=10°, P=30%, AND X=2C

Plot 5-1-2. (Concluded)

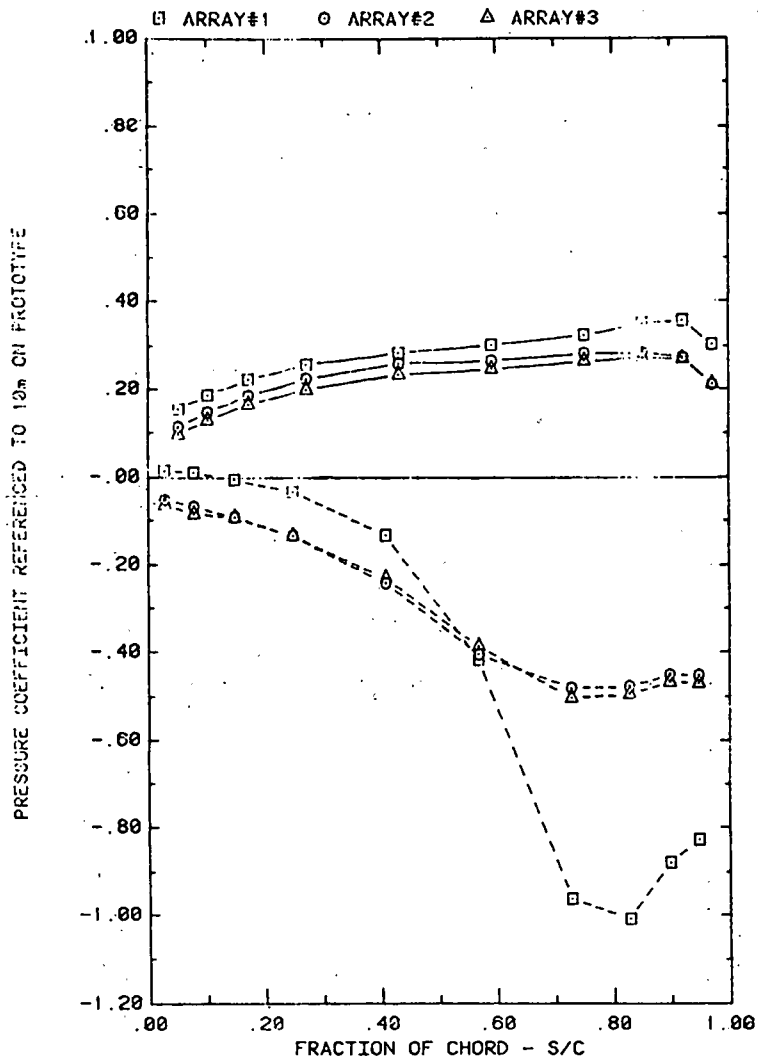

FRONT AND BACK PRESSURES 3.6° IN FROM ARRAY EDGE; $X=2C$; WIND=45
EFFECT OF ARRAY WITH $\alpha=35$, $FC=0$, $H=3^\circ$, $D=10^\circ$, AND $P=30\%$

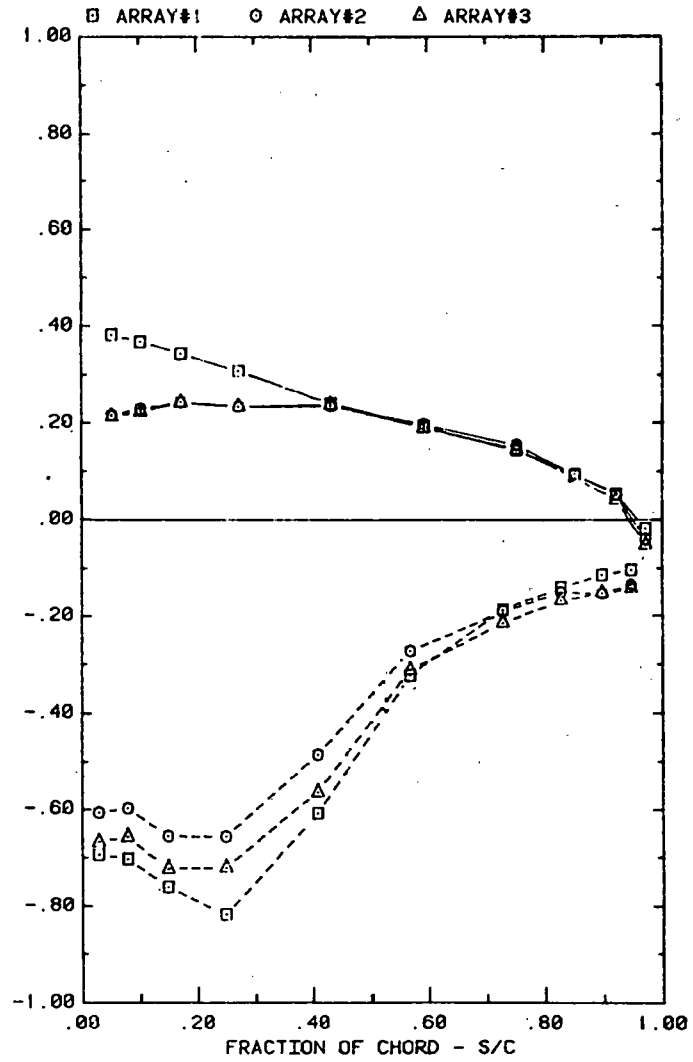

FRONT AND BACK PRESSURES 3.6° IN FROM ARRAY EDGE; $X=2C$; WIND=45
EFFECT OF ARRAY WITH $\alpha=145$, $FC=0$, $H=3^\circ$, $D=10^\circ$, AND $P=30\%$

Plot 5-2-1. Corner Study, $WD = 45^\circ$, Modified Model with Solid Extension
Effect of Array Position

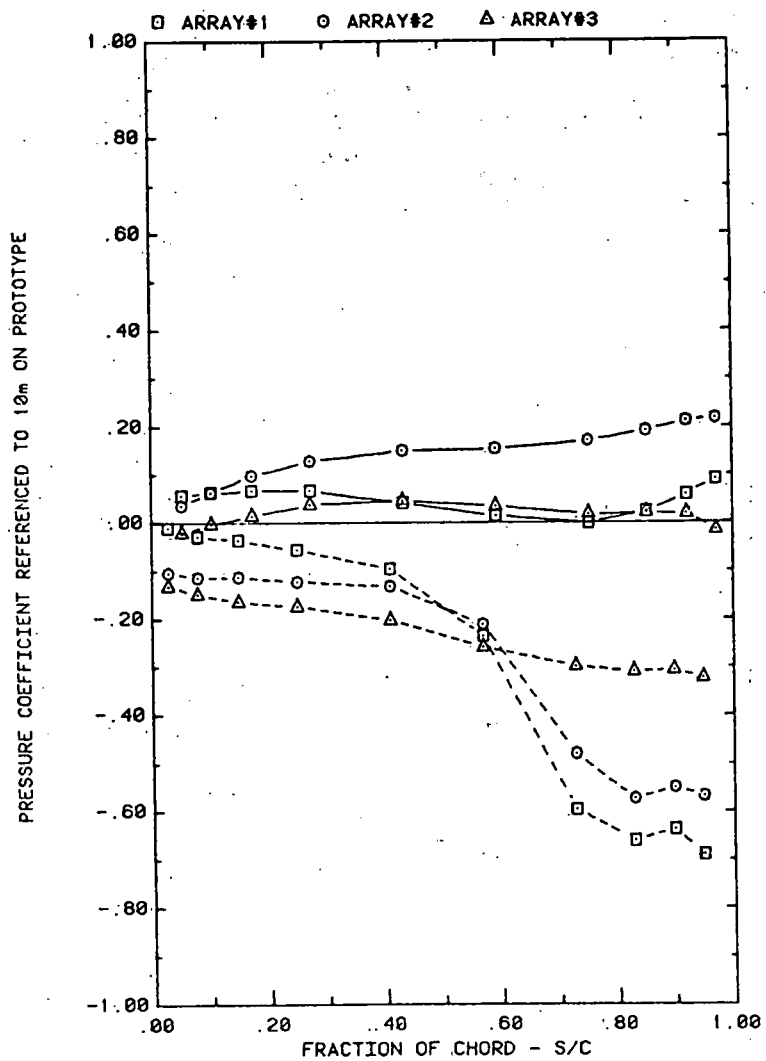

FRONT AND BACK PRESSURES 3.6° IN FROM ARRAY EDGE; X=2C, WIND=45
EFFECT OF ARRAY WITH ALPHA=35, FC=1, H=3°, D=10°, AND P=30%

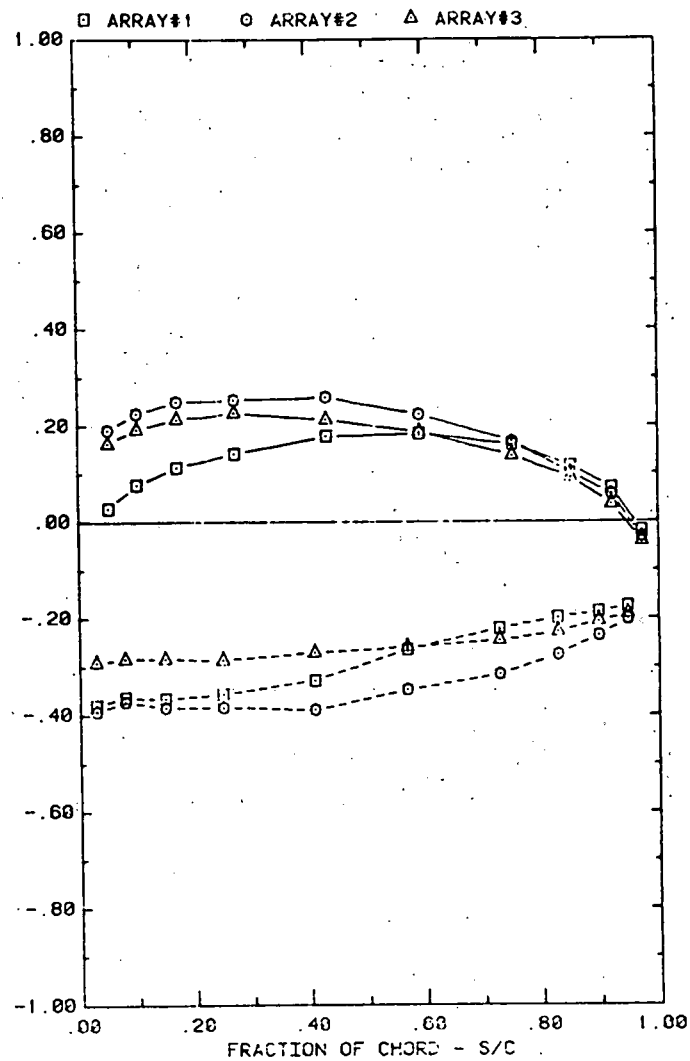

FRONT AND BACK PRESSURES 3.6° IN FROM ARRAY EDGE; X=2C, WIND=45
EFFECT OF ARRAY WITH ALPHA=145, FC=1, H=3°, D=10°, AND P=30%

Plot 5-2-1. (Continued)

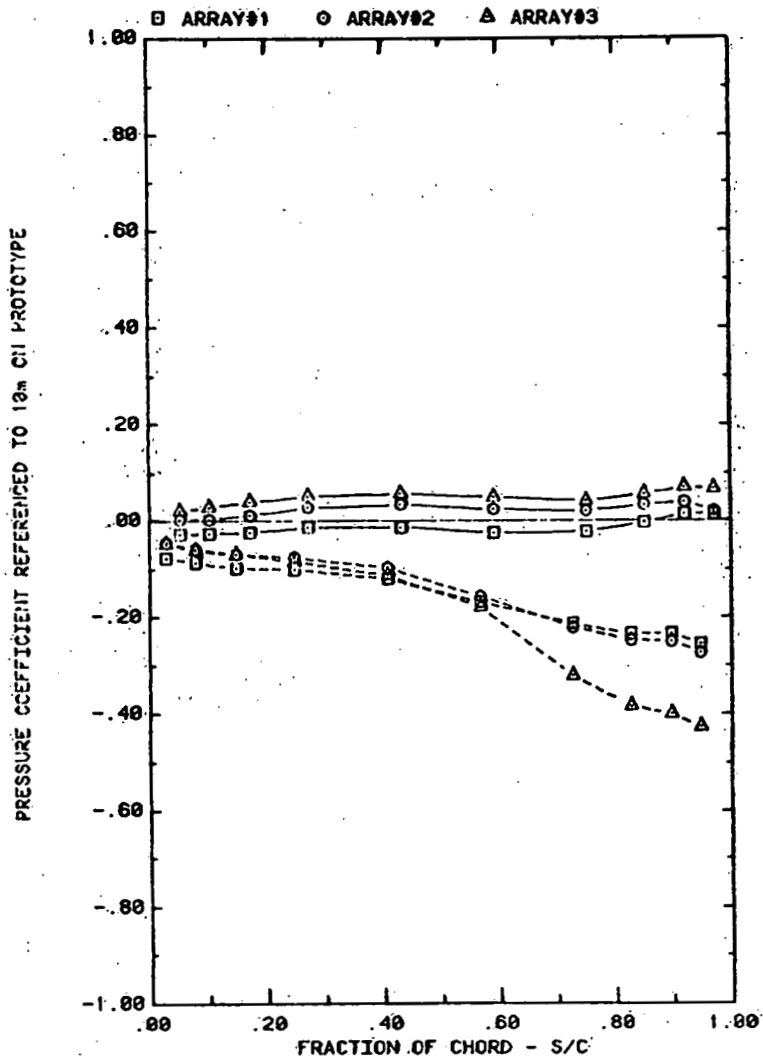

FRONT AND BACK PRESSURES 3.6° IN FROM ARRAY EDGE; X=2C, WIND=45
EFFECT OF ARRAY WITH ALPHA=35, FC=2, H=3°, D=10°, AND P=30%

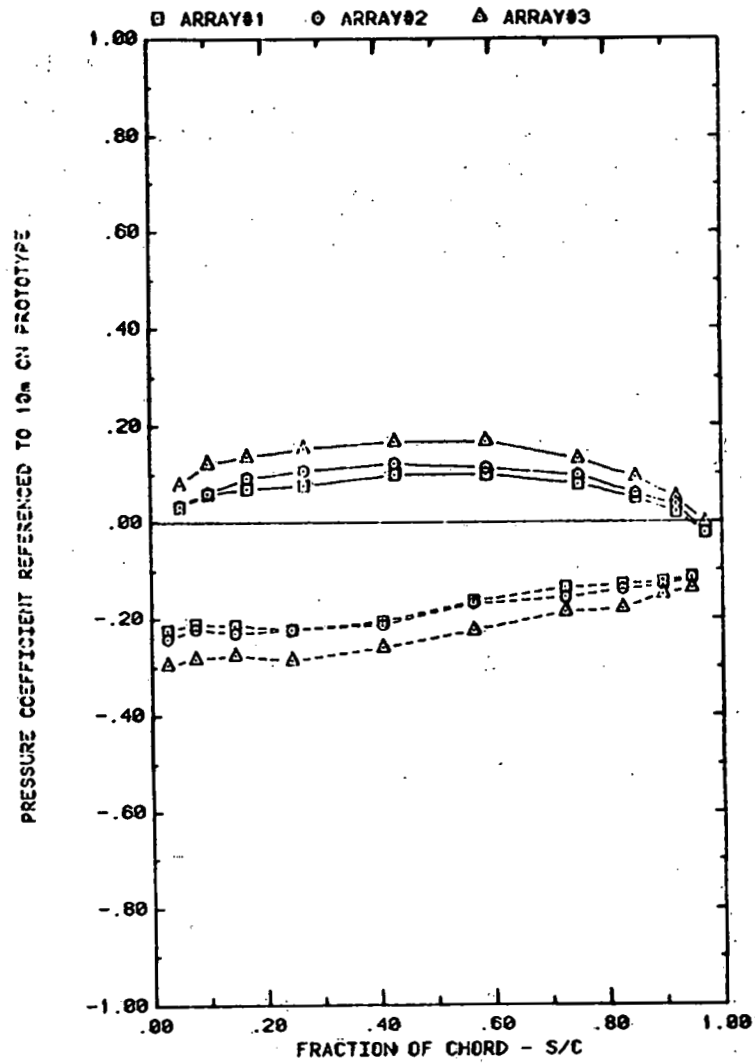

FRONT AND BACK PRESSURES 3.6° IN FROM ARRAY EDGE; X=2C, WIND=45
EFFECT OF ARRAY WITH ALPHA=145, FC=2, H=3°, D=10°, AND P=30%

Plot 5-2-1. (Continued)

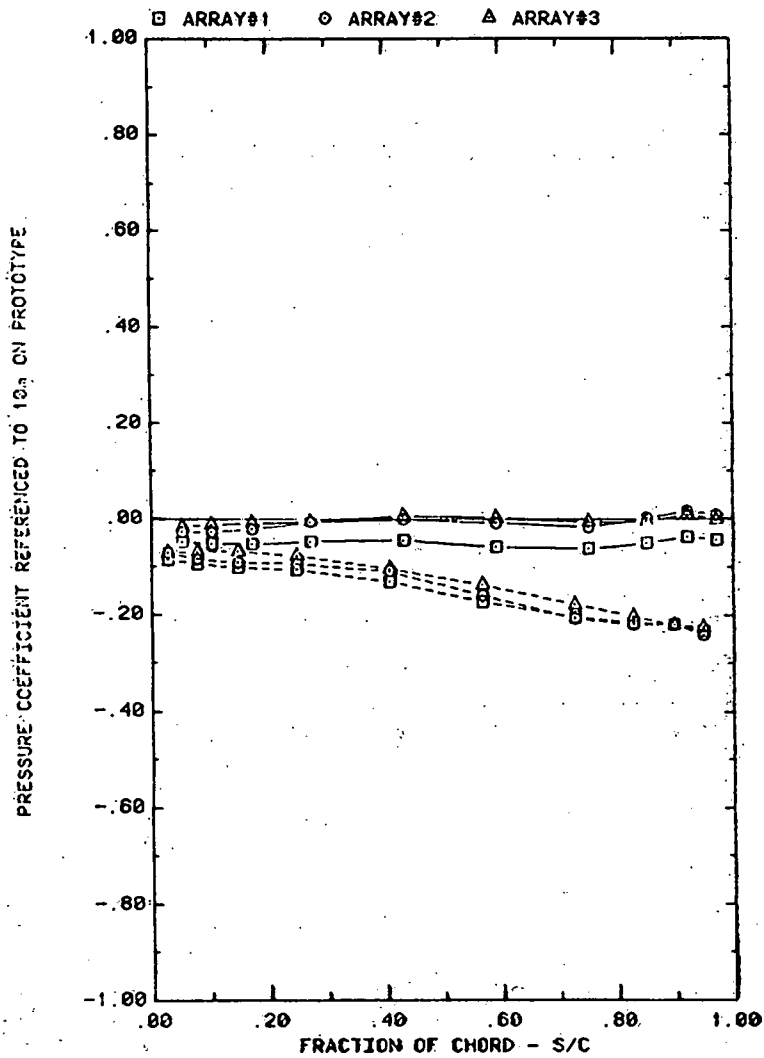

FRONT AND BACK PRESSURES 3.6° IN FROM ARRAY EDGE; X=2C, WIND=45
EFFECT OF ARRAY WITH ALPHA=35, FC=3, H=3°, D=10°, AND P=30%

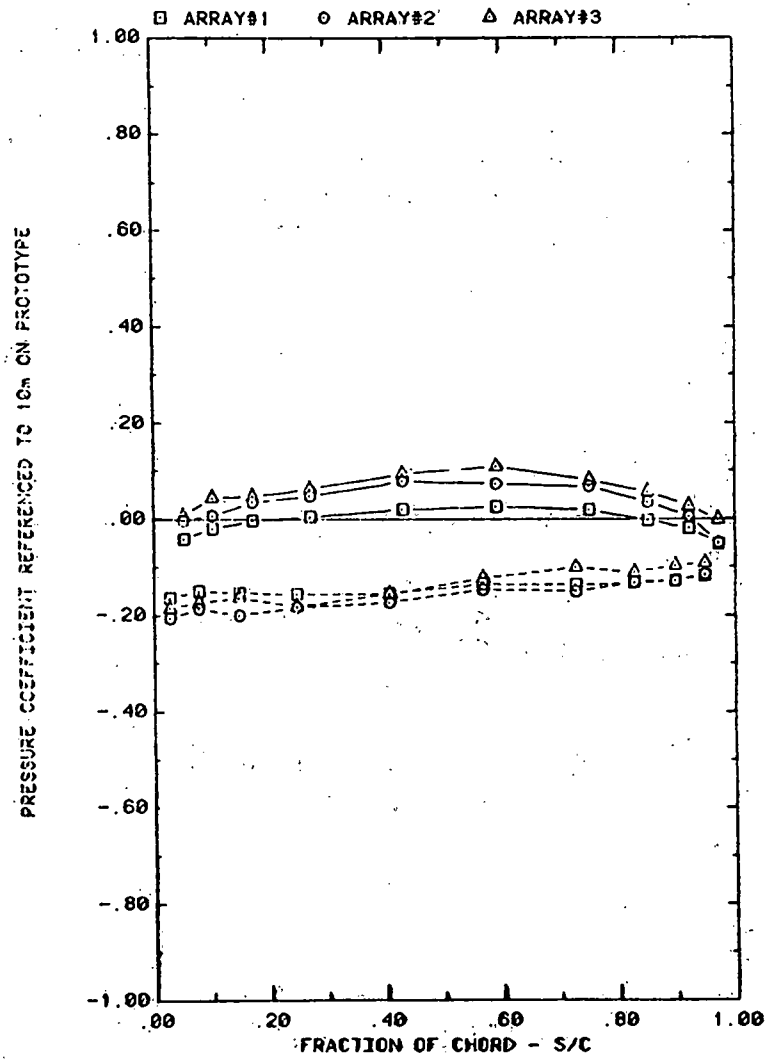

FRONT AND BACK PRESSURES 3.6° IN FROM ARRAY EDGE; X=2C, WIND=45
EFFECT OF ARRAY WITH ALPHA=145, FC=3, H=3°, D=10°, AND P=30%

Plot 5-2-1. (Concluded)

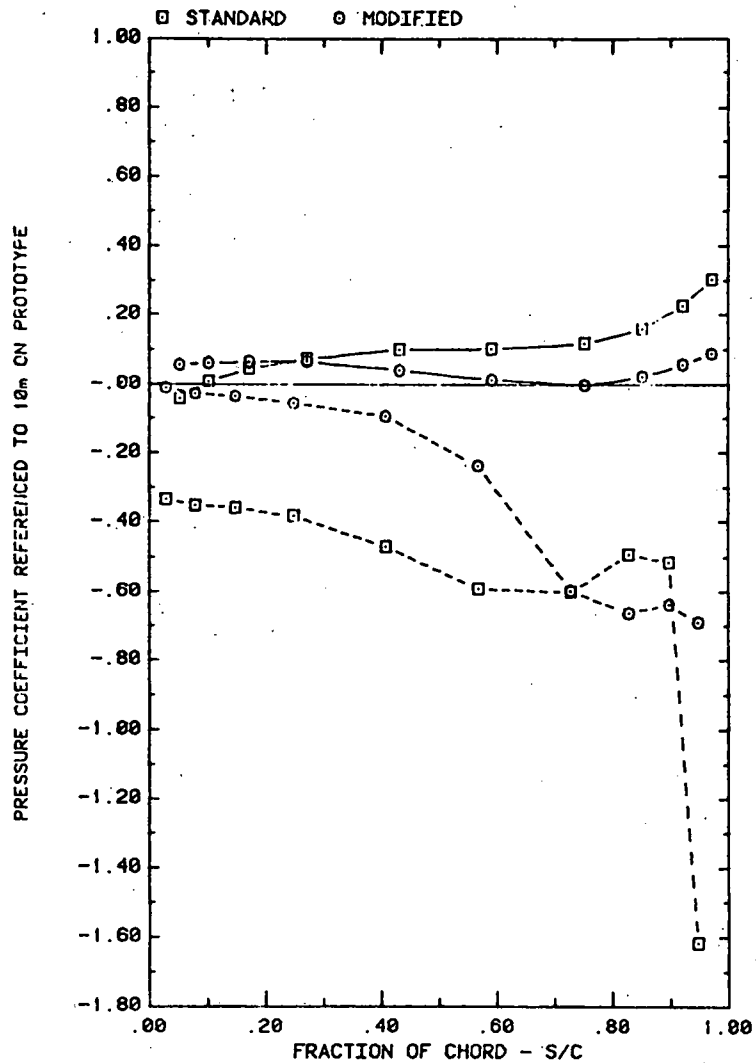

FRONT AND BACK PRESSURES ON ARRAY #1 WITH $X=2C$, AND WIND=45
EFFECT OF TAP LOCATION; ALPHA=35, H=3°, D=10°, FC=1, AND P=30%

Plot 5-2-2. Corner Study, WD = 45°, Effect of Model Modification

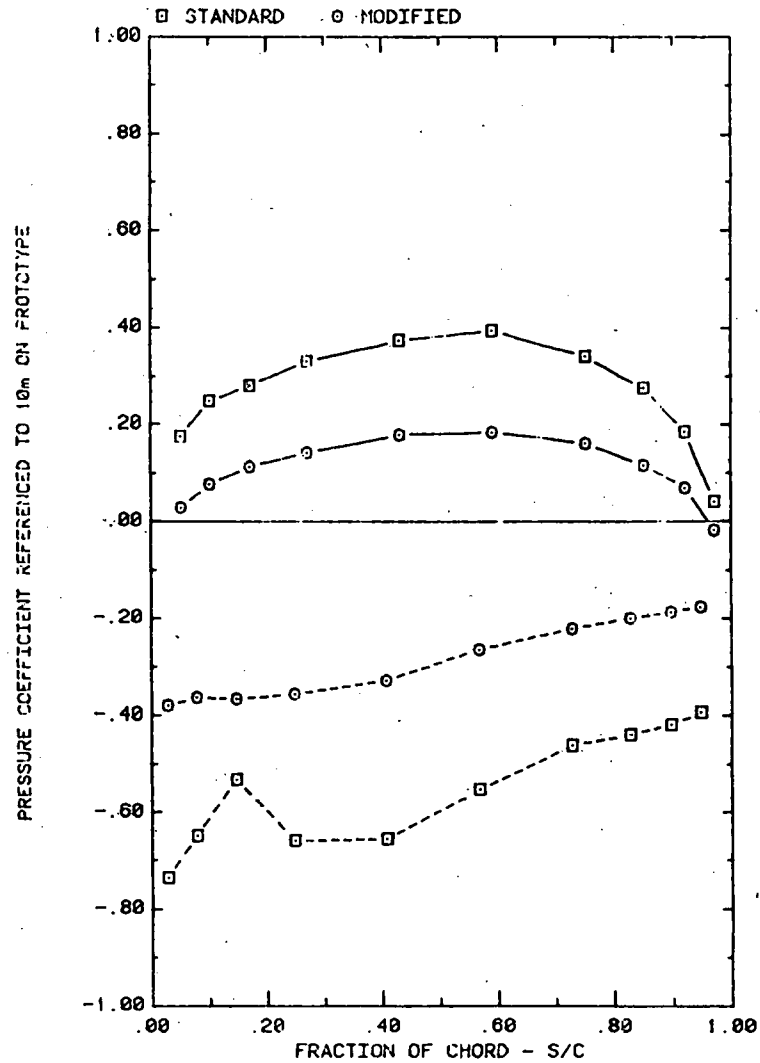

FRONT AND BACK PRESSURES ON ARRAY #1 WITH $X=2C$, AND WIND=45
EFFECT OF TAP LOCATION; ALPHA=145, H=3°, D=10°, FC=1, AND P=30%

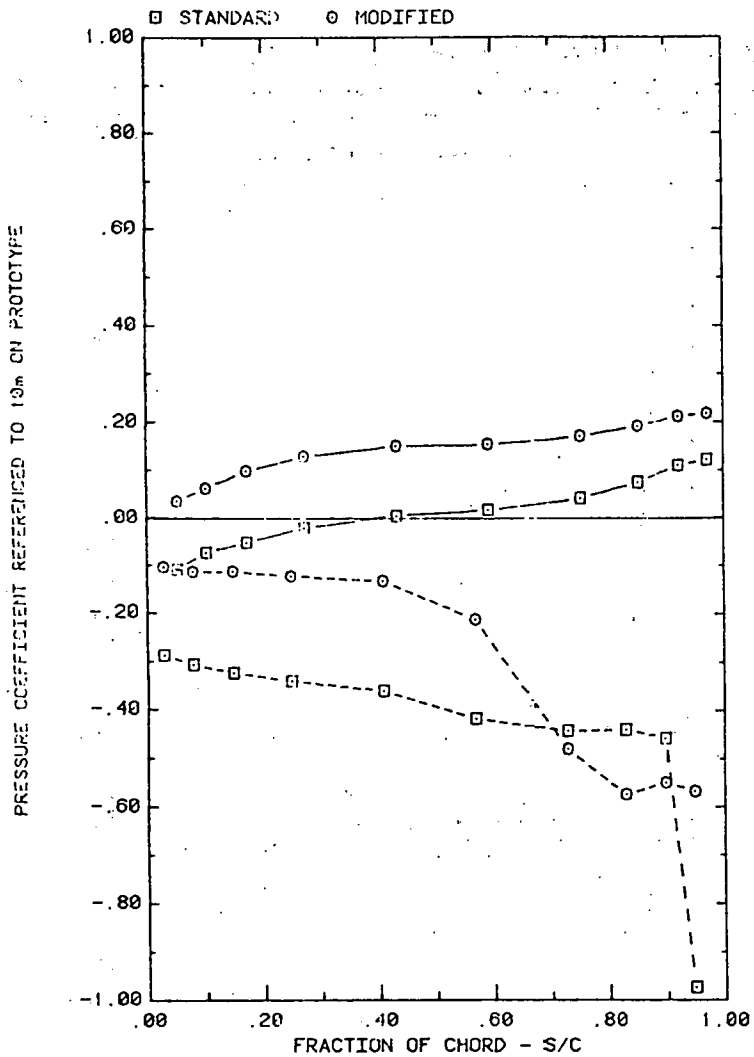

FRONT AND BACK PRESSURES ON ARRAY #2 WITH $X=2C$, AND WIND=45
EFFECT OF TAP LOCATION; $\alpha=35^\circ$, $H=3^\circ$, $D=10^\circ$, $FC=1$, AND $P=30\%$

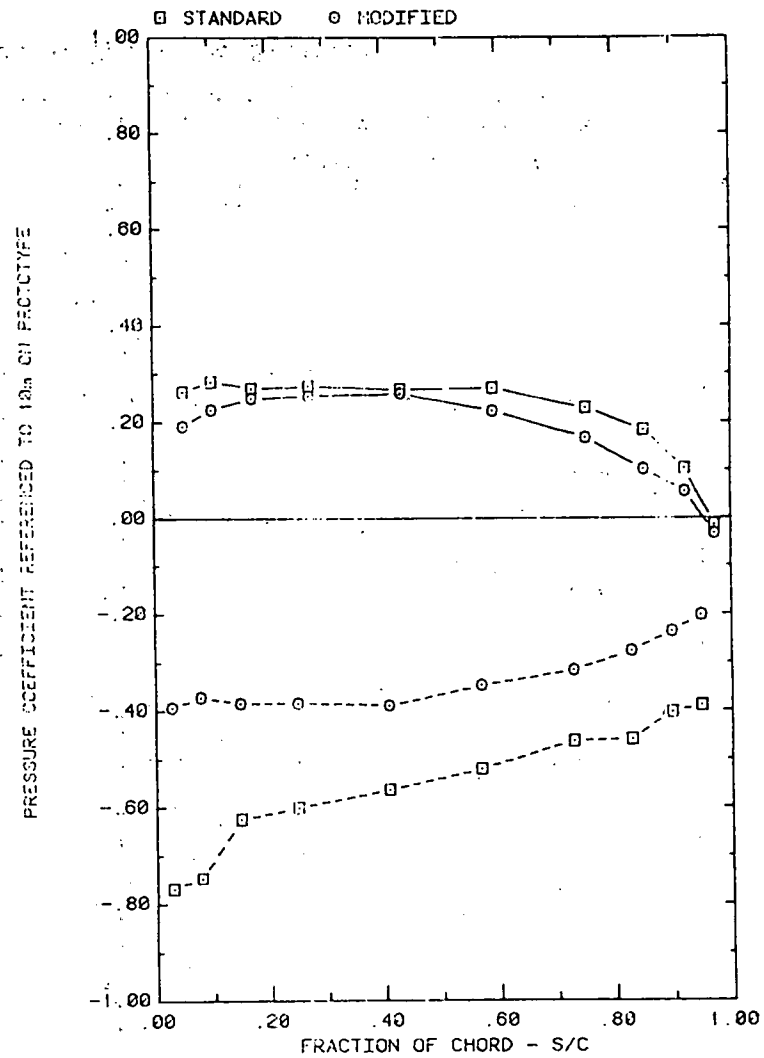

FRONT AND BACK PRESSURES ON ARRAY #2 WITH $X=2C$, AND WIND=45
EFFECT OF TAP LOCATION; $\alpha=145^\circ$, $H=3^\circ$, $D=10^\circ$, $FC=1$, AND $P=30\%$

Plot 5-2-2. (Continued)

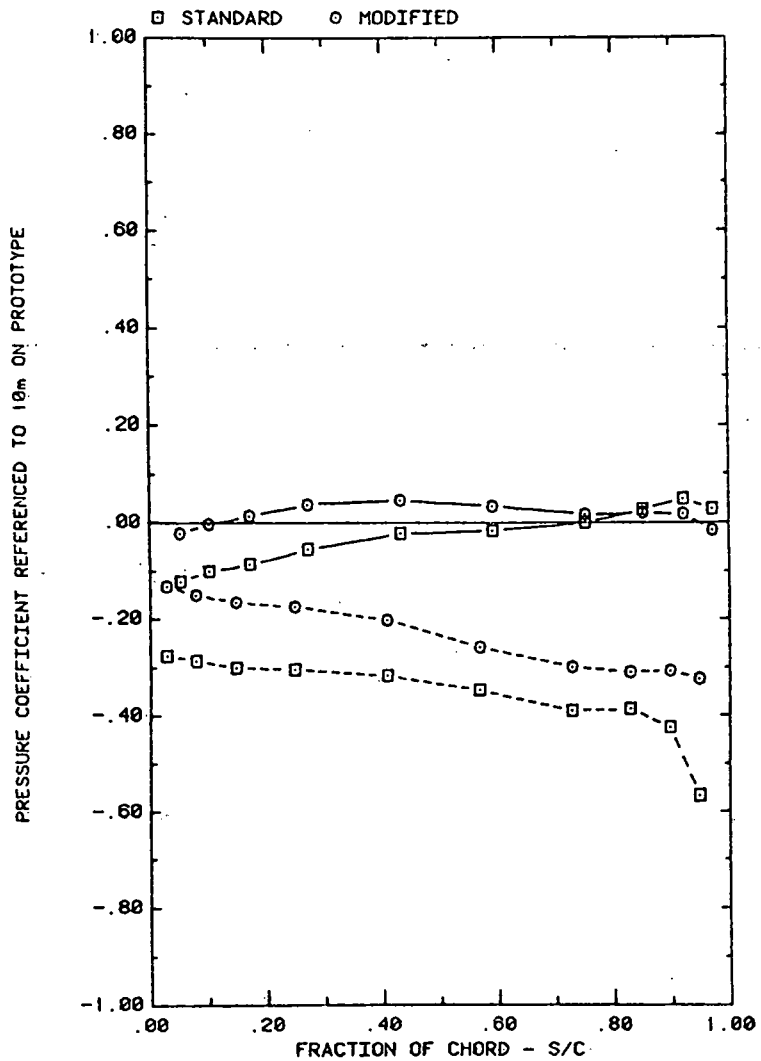

FRONT AND BACK PRESSURES ON ARRAY #3 WITH $X=2C$, AND WIND=45° EFFECT OF TAP LOCATION; $\alpha=35^\circ$, $H=3^\circ$, $D=10^\circ$, $FC=1$, AND $P=30\%$

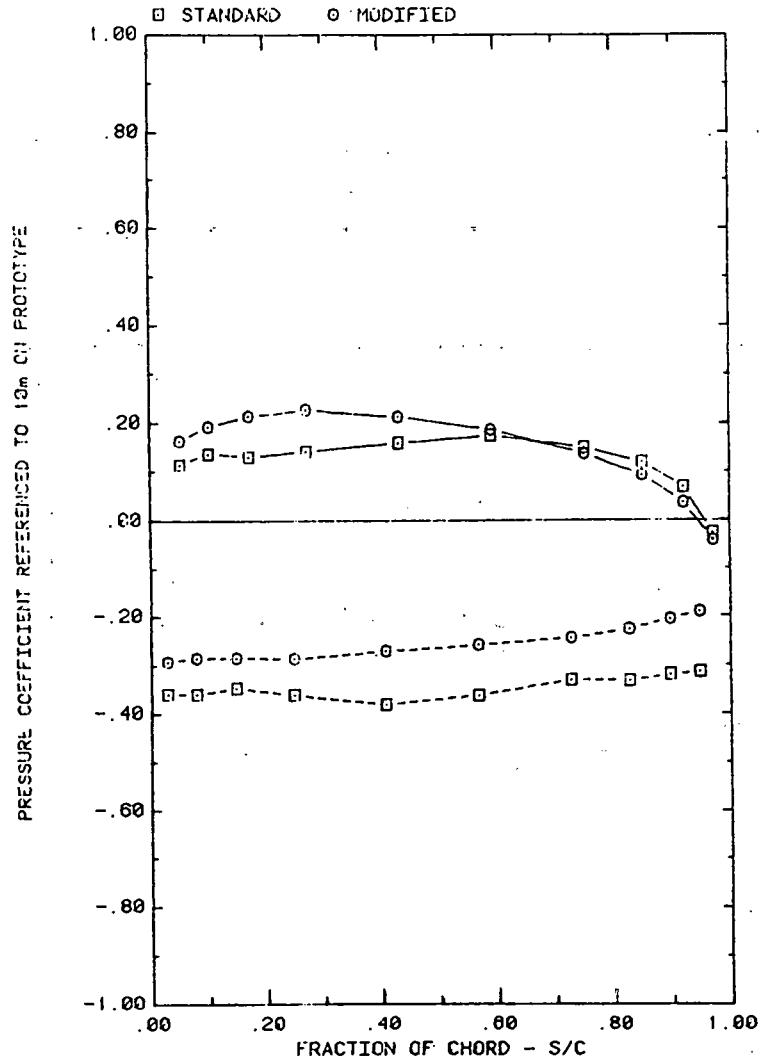

FRONT AND BACK PRESSURES ON ARRAY #3 WITH $X=2C$, AND WIND=45° EFFECT OF TAP LOCATION; $\alpha=145^\circ$, $H=3^\circ$, $D=10^\circ$, $FC=1$, AND $P=30\%$

Plot 5-2-2: (Continued)

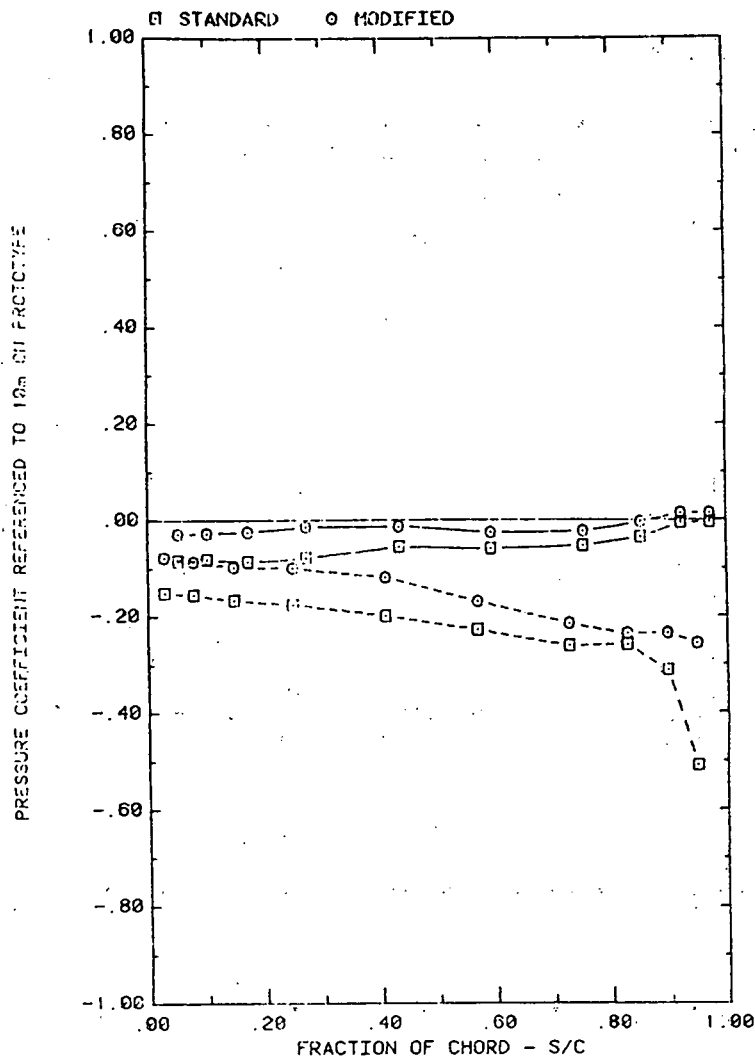

FRONT AND BACK PRESSURES ON ARRAY #1 WITH $X=2C$, AND WIND=45
EFFECT OF TAP LOCATION; $\alpha=35$, $H=3''$, $D=10''$, $FC=2$, AND $P=30\%$

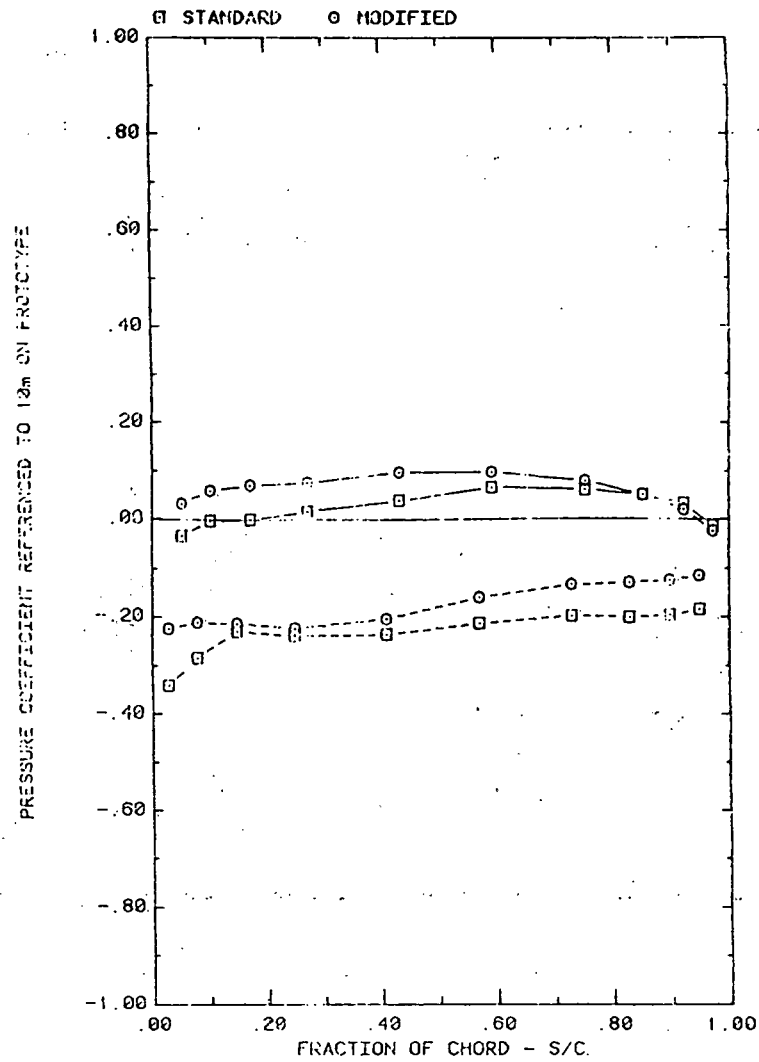

FRONT AND BACK PRESSURES ON ARRAY #1 WITH $X=2C$, AND WIND=45
EFFECT OF TAP LOCATION; $\alpha=145$, $H=3''$, $D=10''$, $FC=2$, AND $P=30\%$

Plot 5-2-2. (Continued)

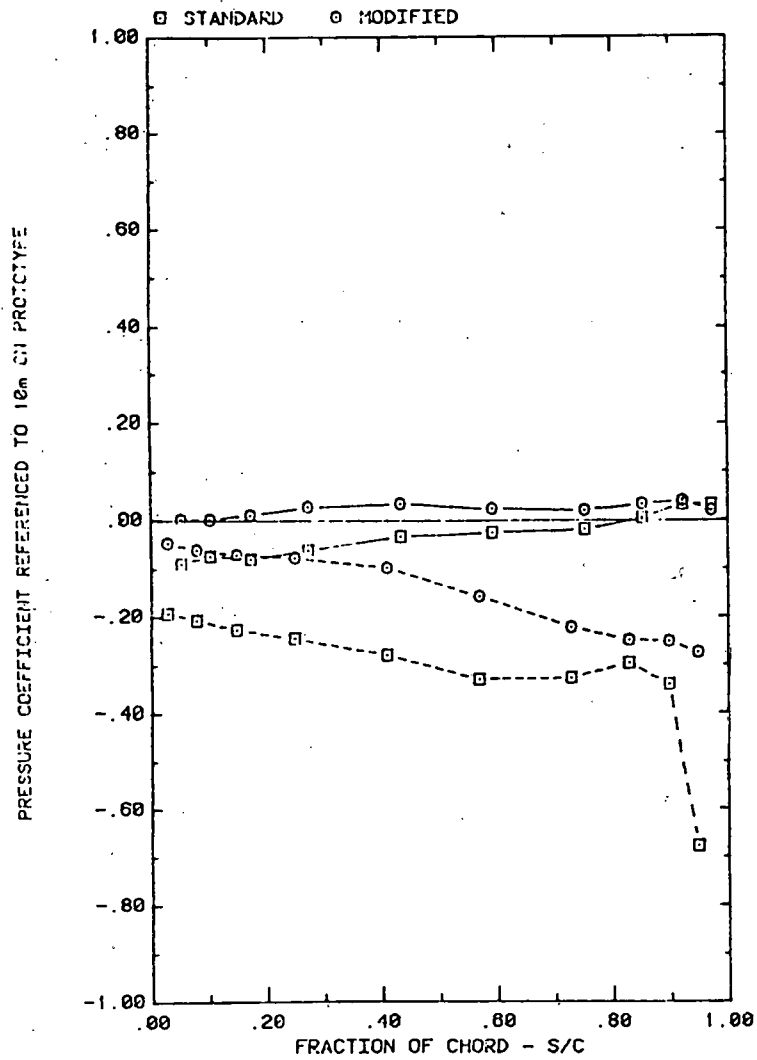

FRONT AND BACK PRESSURES ON ARRAY #2 WITH $X=2C$, AND WIND=45
EFFECT OF TAP LOCATION; ALPHA=35, H=3°, D=10°, FC=2, AND P=30%

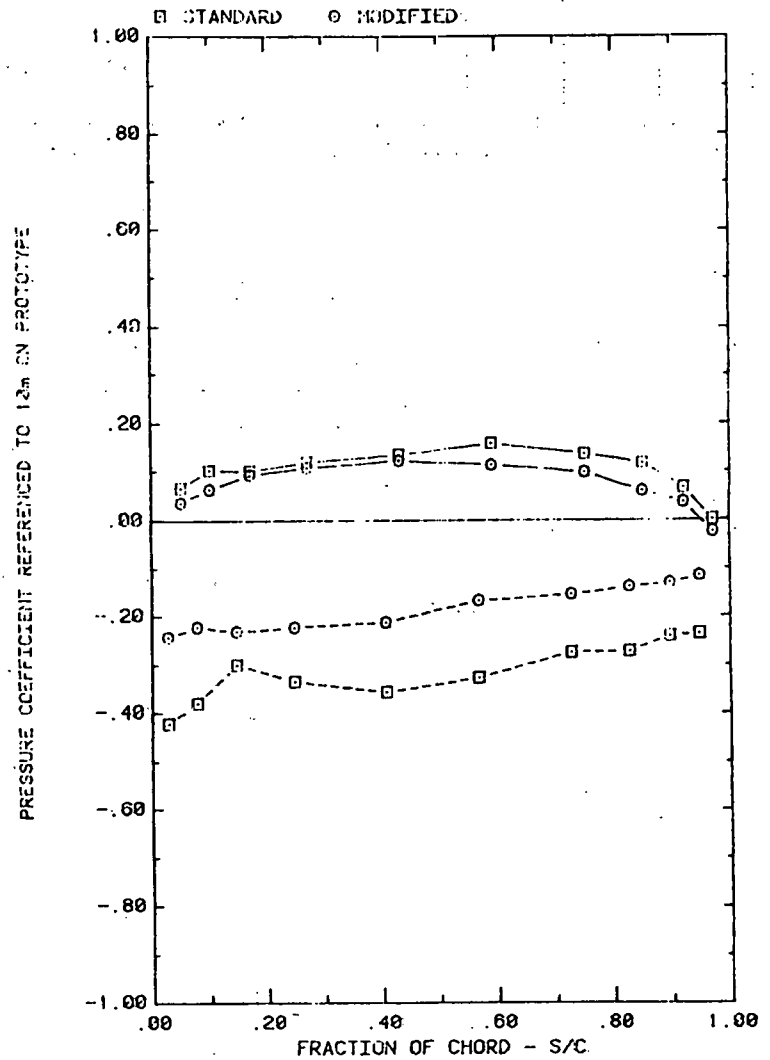

FRONT AND BACK PRESSURES ON ARRAY #2 WITH $X=2C$, AND WIND=45
EFFECT OF TAP LOCATION; ALPHA=145, H=3°, D=10°, FC=2°, AND P=30%

Plot 5-2-2. (Continued)

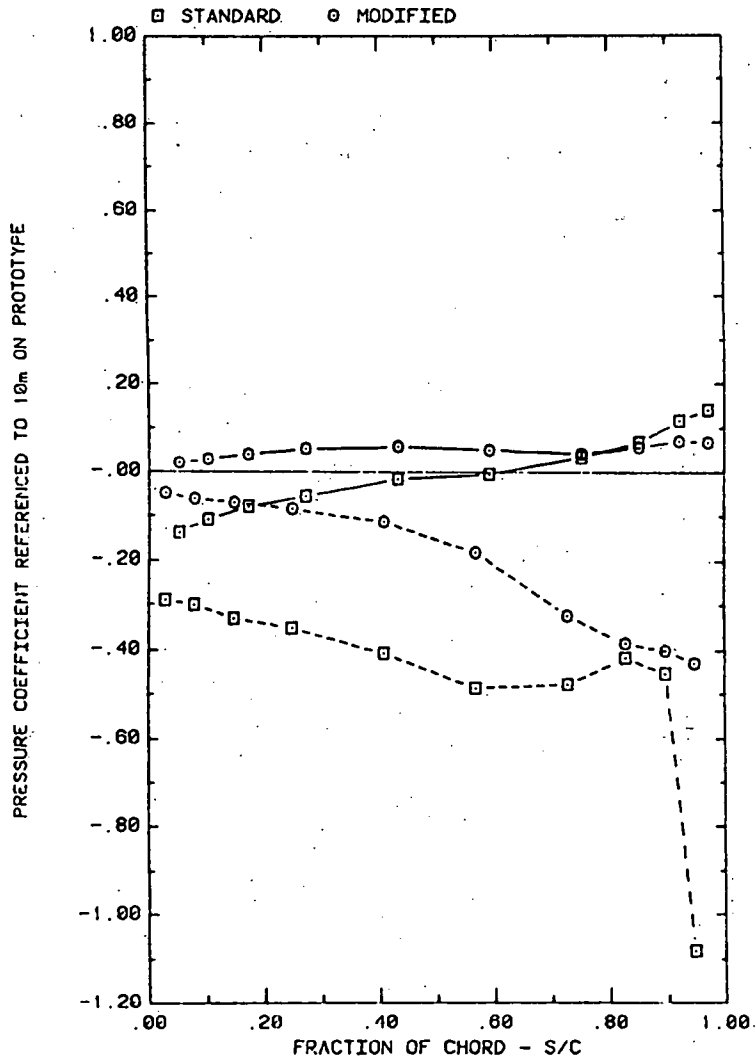

FRONT AND BACK PRESSURES ON ARRAY #3 WITH X=2C, AND WIND=45
EFFECT OF TAP LOCATION; ALPHA=35, H=3°, D=10°, FC=2, AND P=30%

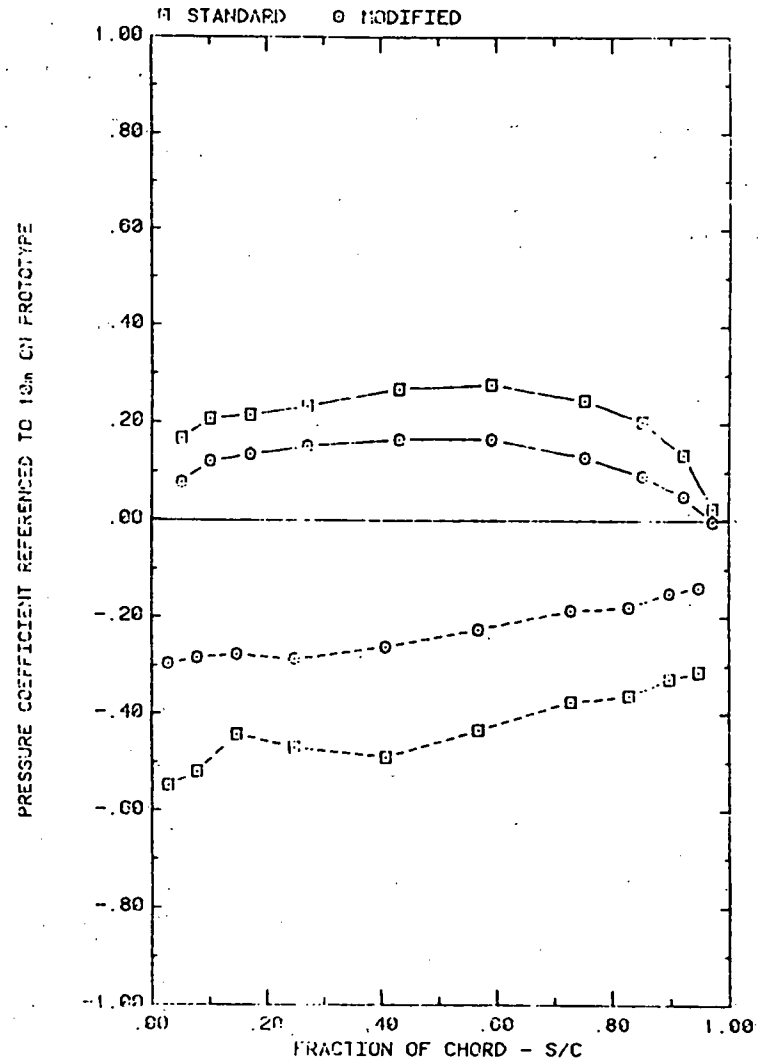

FRONT AND BACK PRESSURES ON ARRAY #3 WITH X=2C, AND WIND=45
EFFECT OF TAP LOCATION; ALPHA=145, H=3°, D=10°, FC=2, AND P=30%

Plot 5-2-2. (Continued)

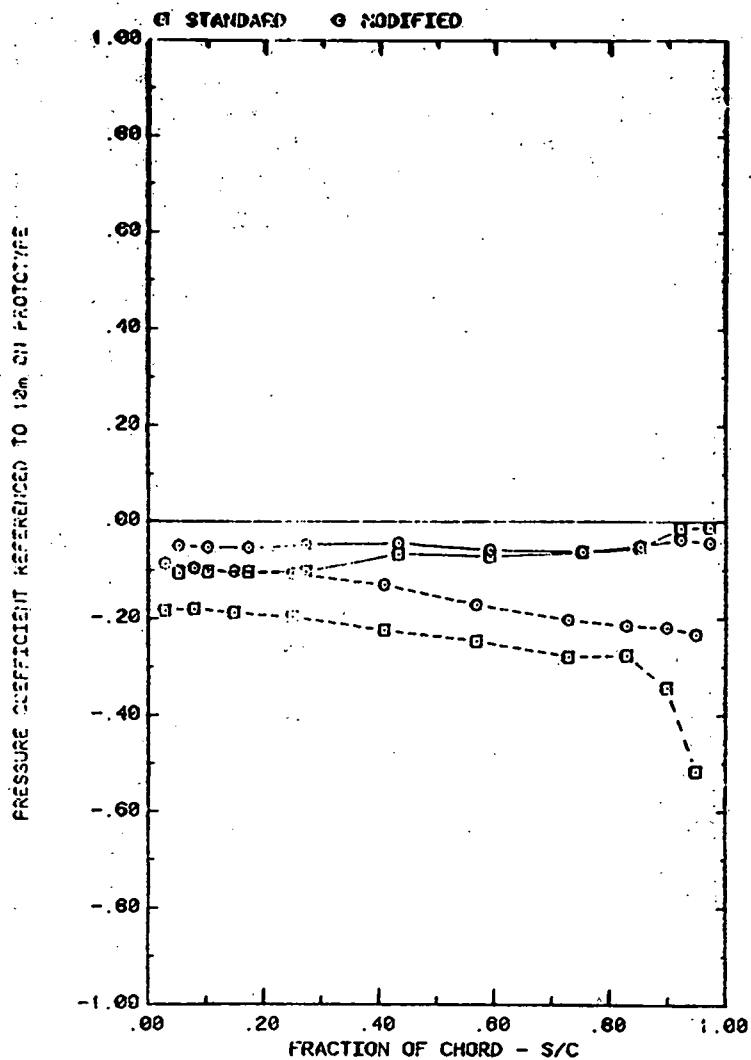

FRONT AND BACK PRESSURES ON ARRAY #1 WITH $X=2C$, AND WIND=45
EFFECT OF TAP LOCATION; $\alpha=35$, $H=3^\circ$, $D=10^\circ$, $FC=3$, AND $P=30\%$

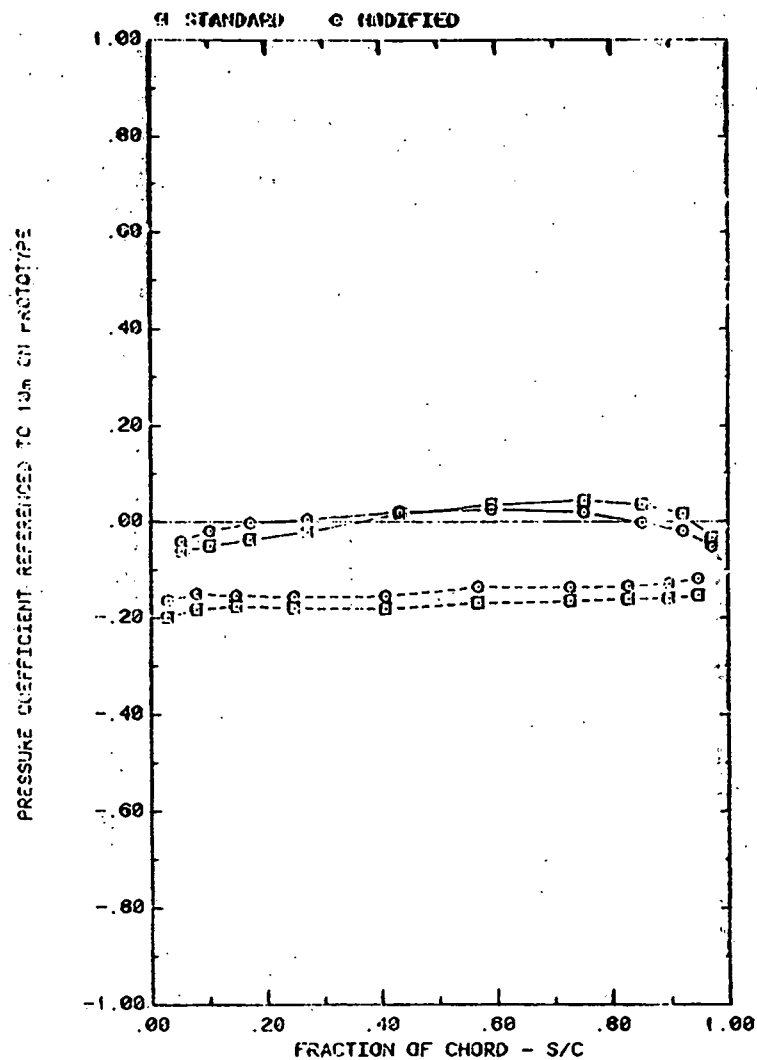

FRONT AND BACK PRESSURES ON ARRAY #1 WITH $X=2C$, AND WIND=45
EFFECT OF TAP LOCATION; $\alpha=145$, $H=3^\circ$, $D=10^\circ$, $FC=3$, AND $P=30\%$

Plot 5-2-2. (Continued)

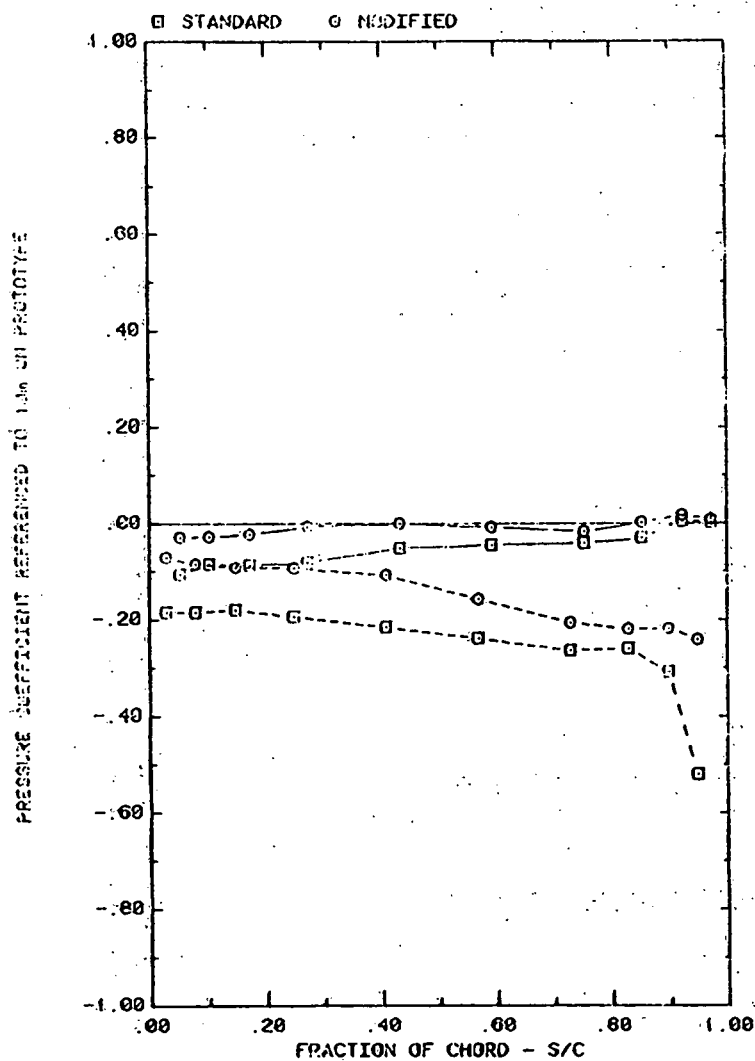

FRONT AND BACK PRESSURES ON ARRAY #2 WITH $X=2C$, AND WIND=45
EFFECT OF TAP LOCATION; $\alpha=35^\circ$, $H=3^\circ$, $D=10^\circ$, $FC=3$, AND $P=30\%$

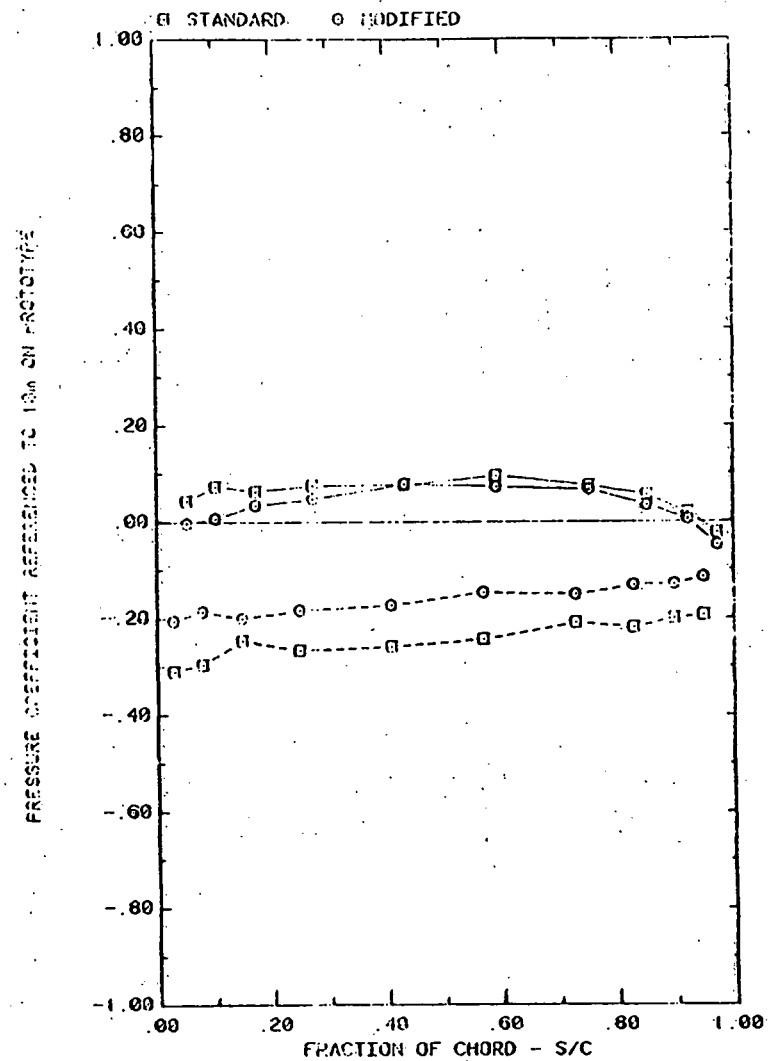

FRONT AND BACK PRESSURES ON ARRAY #2 WITH $X=2C$, AND WIND=45
EFFECT OF TAP LOCATION; $\alpha=145^\circ$, $H=3^\circ$, $D=10^\circ$, $FC=3$, AND $P=30\%$

Plot 5-2-2: (Continued)

C-115

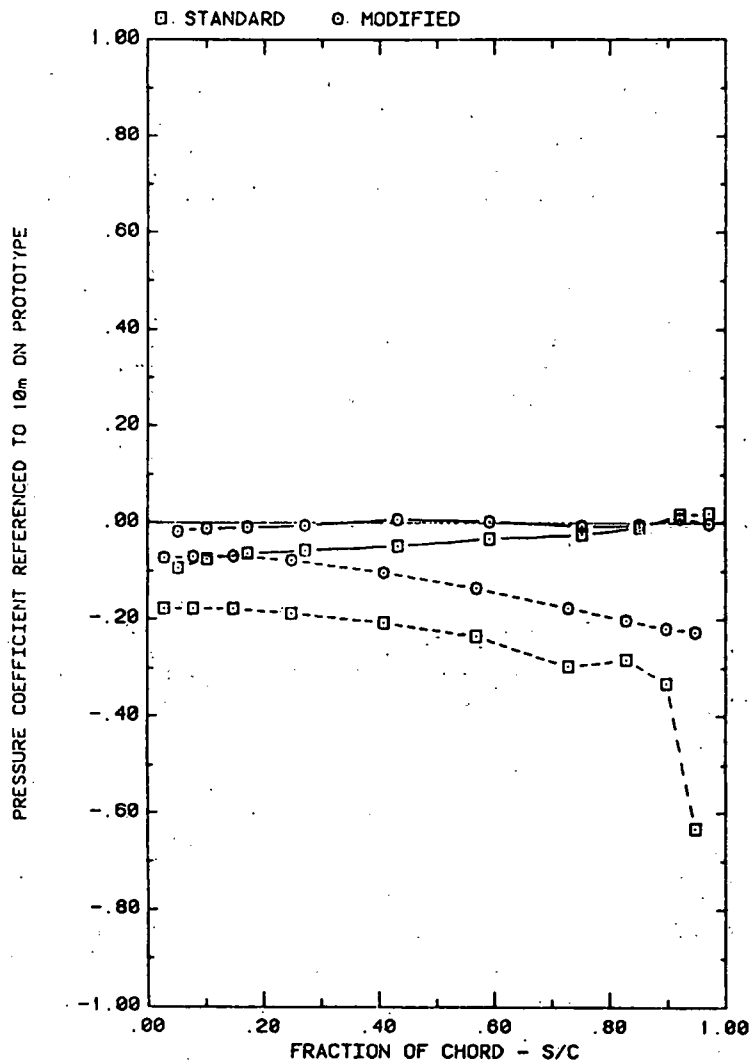

FRONT AND BACK PRESSURES ON ARRAY #3 WITH X=2C, AND WIND=45
EFFECT OF TAP LOCATION; ALPHA=35, H=3°, D=10°, FC=3, AND P=30%

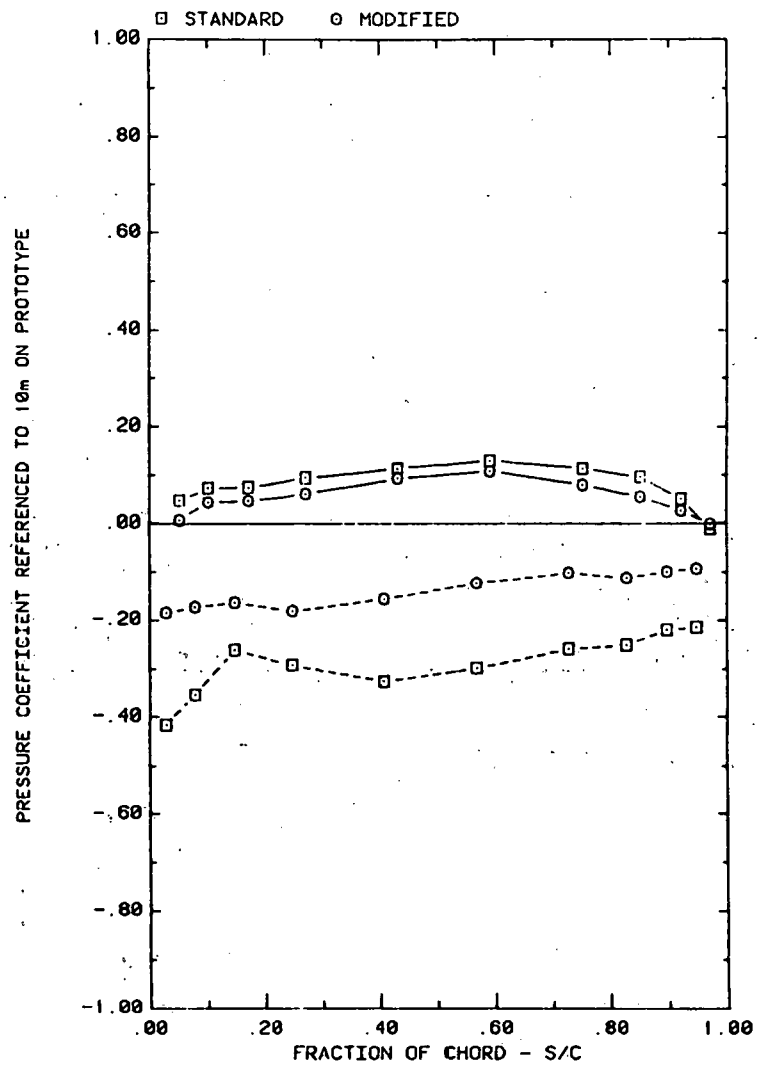

FRONT AND BACK PRESSURES ON ARRAY #3 WITH X=2C, AND WIND=45
EFFECT OF TAP LOCATION; ALPHA=145, H=3°, D=10°, FC=3, AND P=30%

Plot 5-2-2. (Concluded)

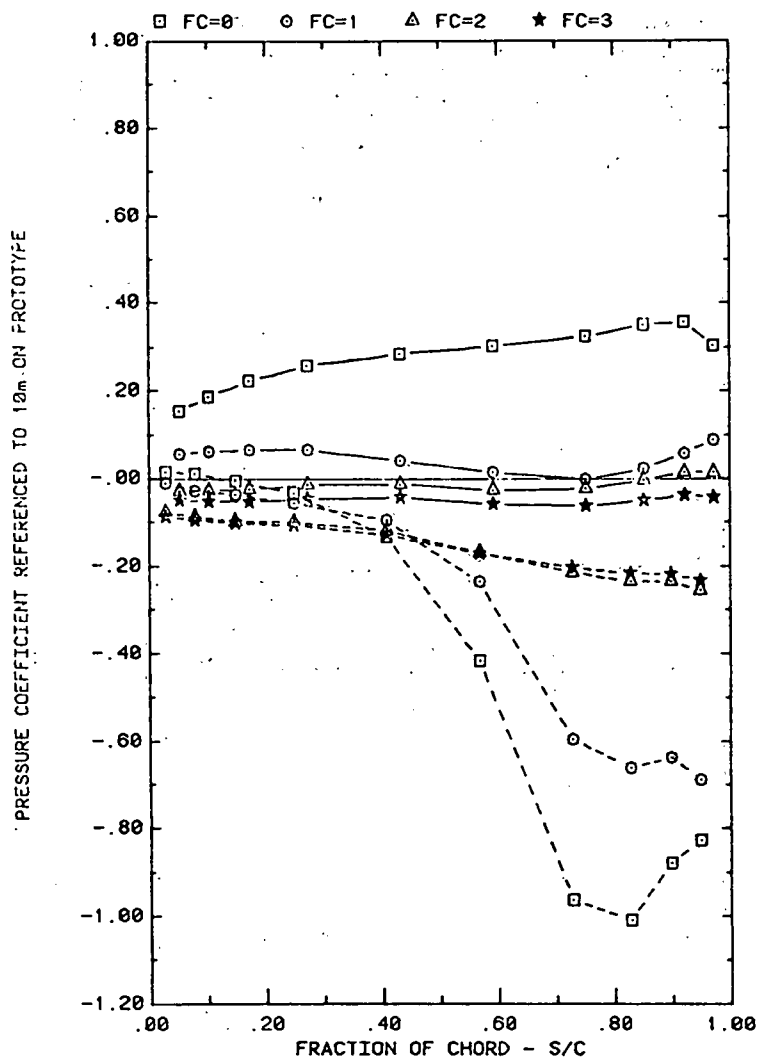

FRONT AND BACK PRESSURES 3.6° IN FROM EDGE OF ARRAY#1; WIND=45
EFFECT OF FC WITH ALPHA=35, H=3°, D=10°, P=30%, AND X=2C

Plot 5-2-3. Corner Study, WD = 45°, Modified Model with Solid Extension
Effect of Fence Configuration

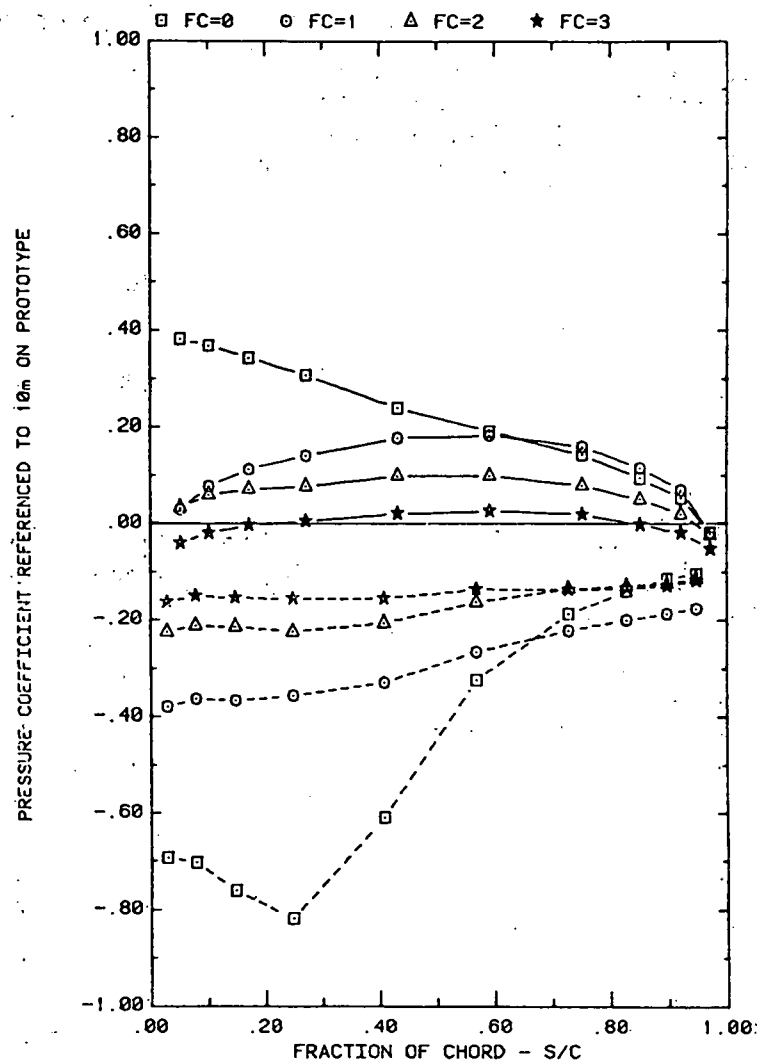

FRONT AND BACK PRESSURES 3.6° IN FROM EDGE OF ARRAY#1; WIND=45
EFFECT OF FC WITH ALPHA=145, H=3°, D=10°, P=30%, AND X=2C

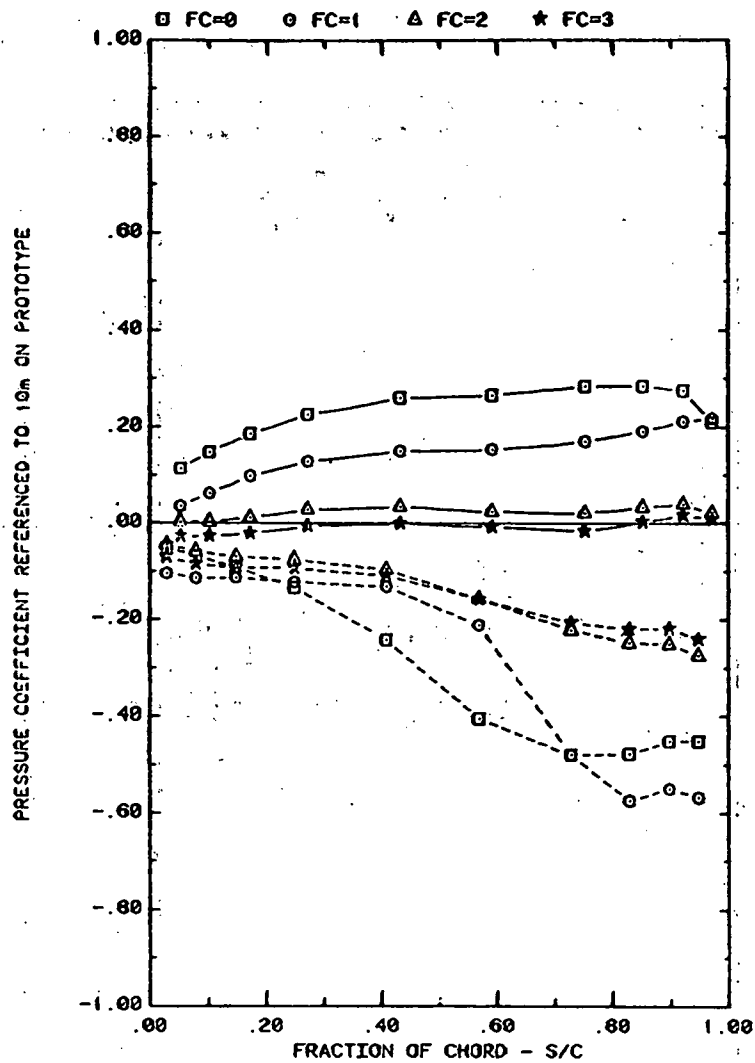

FRONT AND BACK PRESSURES 3.6° IN FROM EDGE OF ARRAY#2; WIND=45
EFFECT OF FC WITH ALPHA=35, H=3°, D=10°, P=30%, AND X=2C

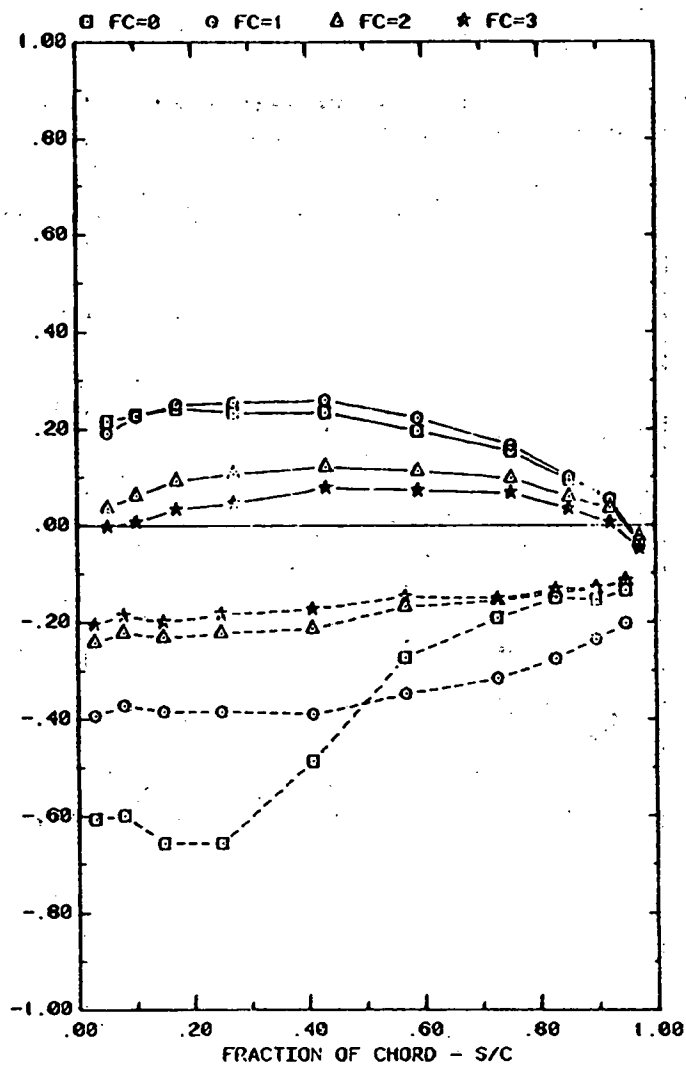

FRONT AND BACK PRESSURES 3.6° IN FROM EDGE OF ARRAY#2; WIND=45
EFFECT OF FC WITH ALPHA=145, H=3°, D=10°, P=30%, AND X=2C

Plot 5-2-3. (Continued)

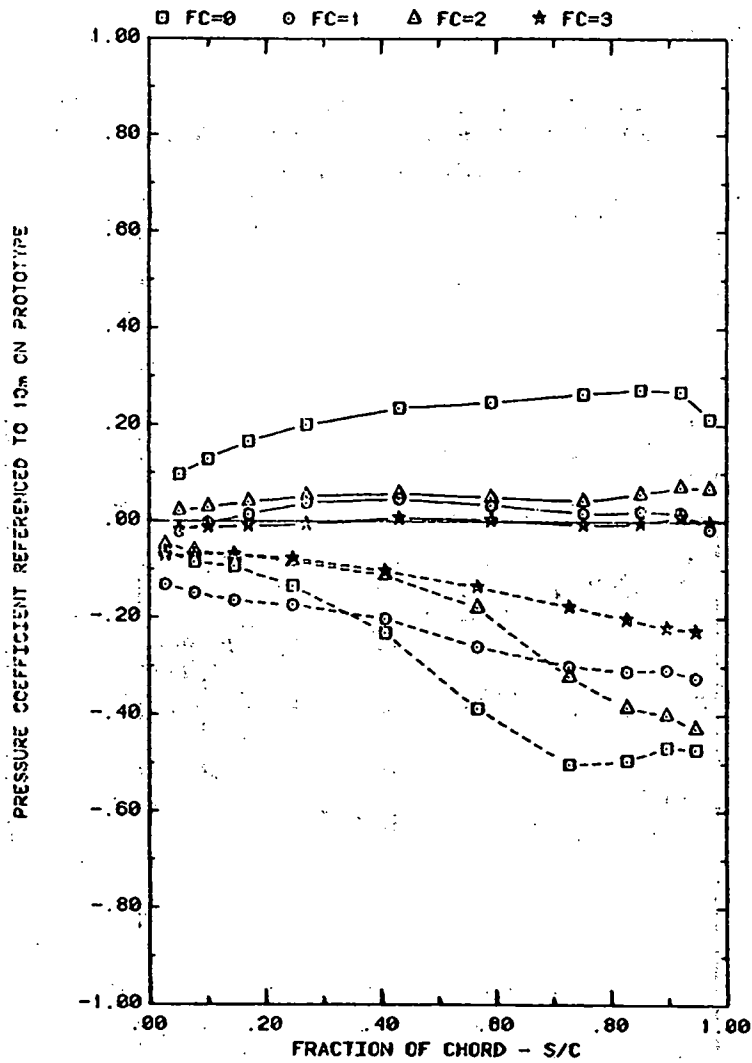

FRONT AND BACK PRESSURES 3.6° IN FROM EDGE OF ARRAY#3; WIND=45
EFFECT OF FC WITH ALPHA=35, H=3°, D=10°, P=30%, AND X=2C

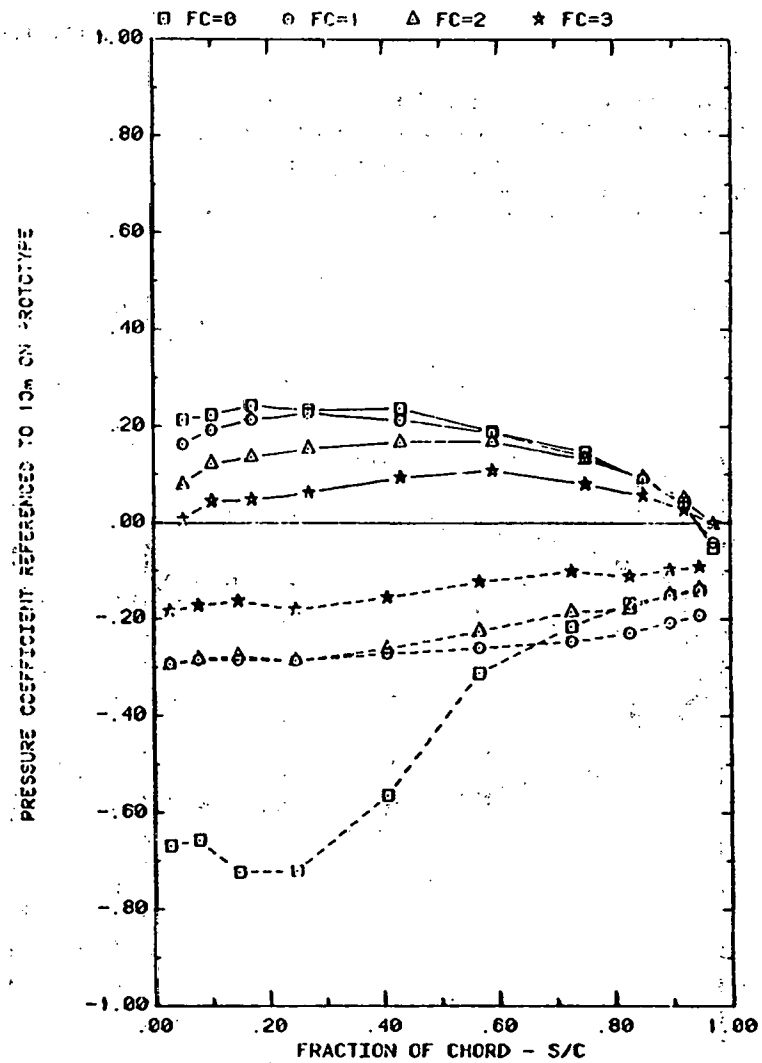

FRONT AND BACK PRESSURES 3.6° IN FROM EDGE OF ARRAY#3; WIND=45
EFFECT OF FC WITH ALPHA=145, H=3°, D=10°, P=30%, AND X=2C

Plot 5-2-3. (Concluded)

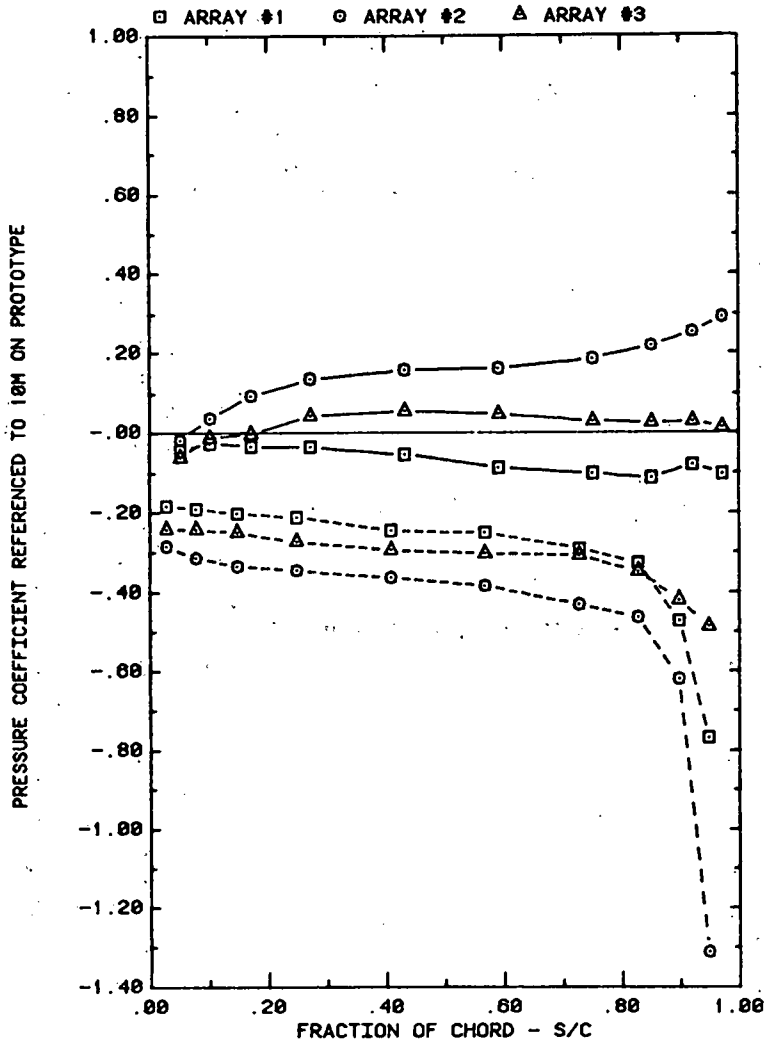

FRONT AND BACK PRESSURES ON ARRAYS #1,2&3\50% POROSITY EXTENSION
EFFECT OF ARRAY WITH ALPHA = 35, WIND = 45, X = 2C, FC = 1

Plot 5-3-1. Corner Study, WD = 45°, Modified Model with Various Extension
Effect of Array Position

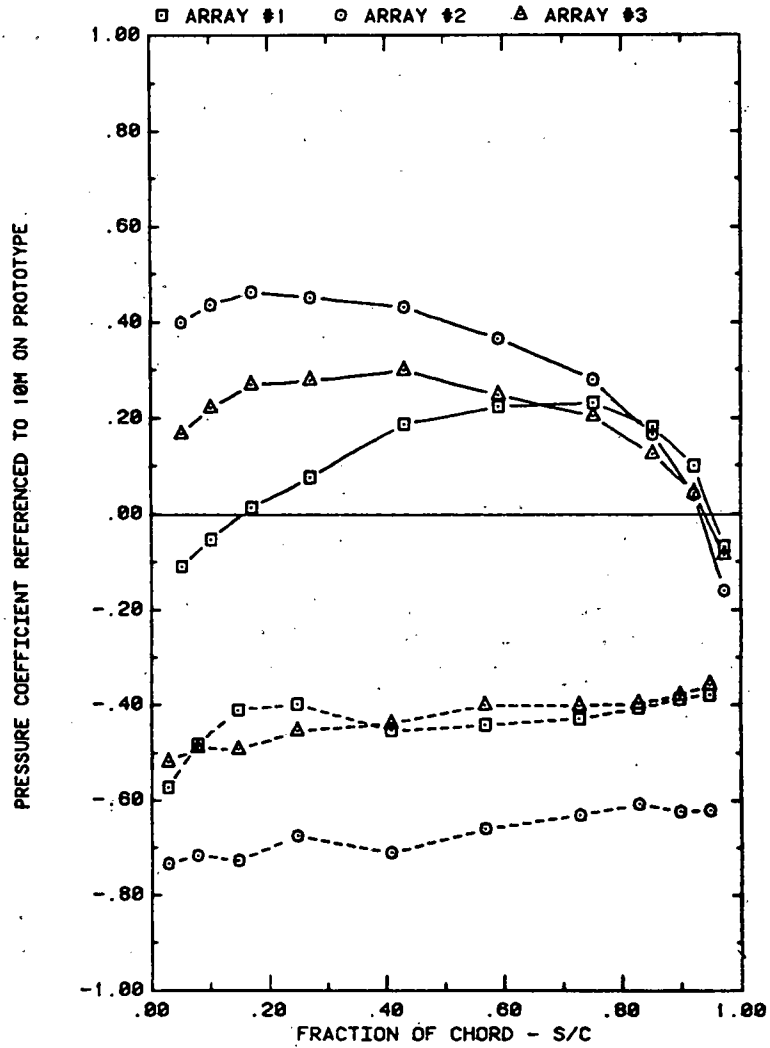

FRONT AND BACK PRESSURES ON ARRAYS #1,2&3\50% POROSITY EXTENSION
EFFECT OF ARRAY WITH ALPHA = 145, WIND = 45, X = 2C, FC = 1

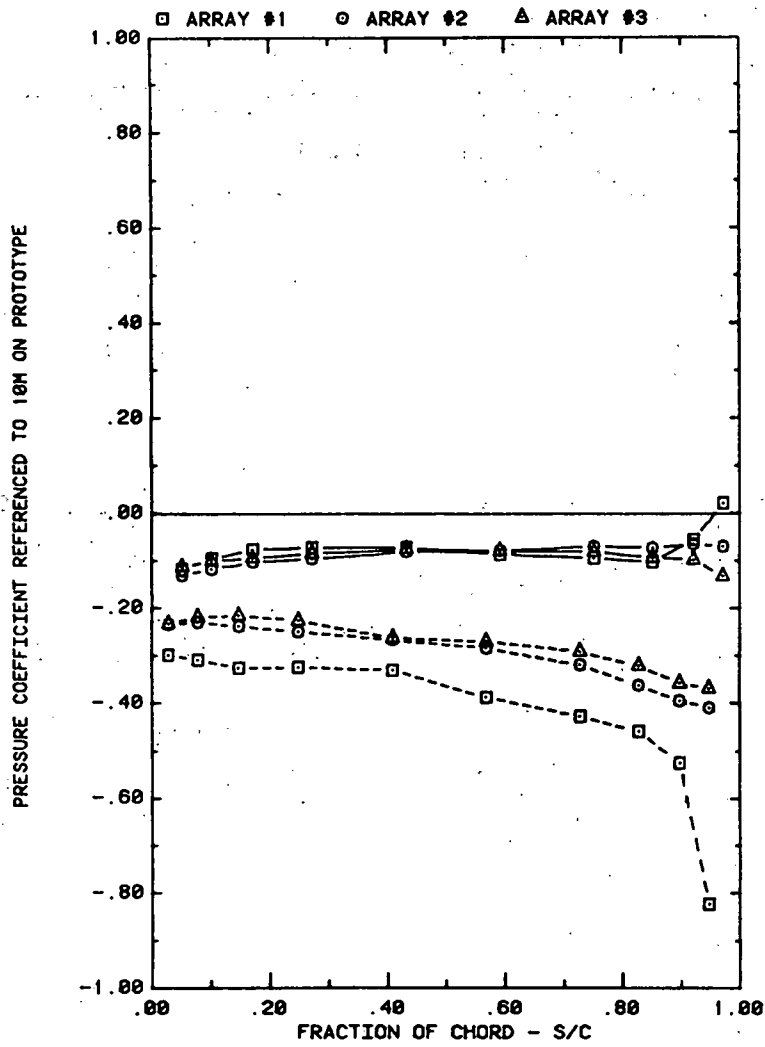

FRONT AND BACK PRESSURES ON ARRAYS #1, 2 & 3 \END PLATE
EFFECT OF ARRAY WITH ALPHA = 35, WIND = 45, X = 2C, FC = 1

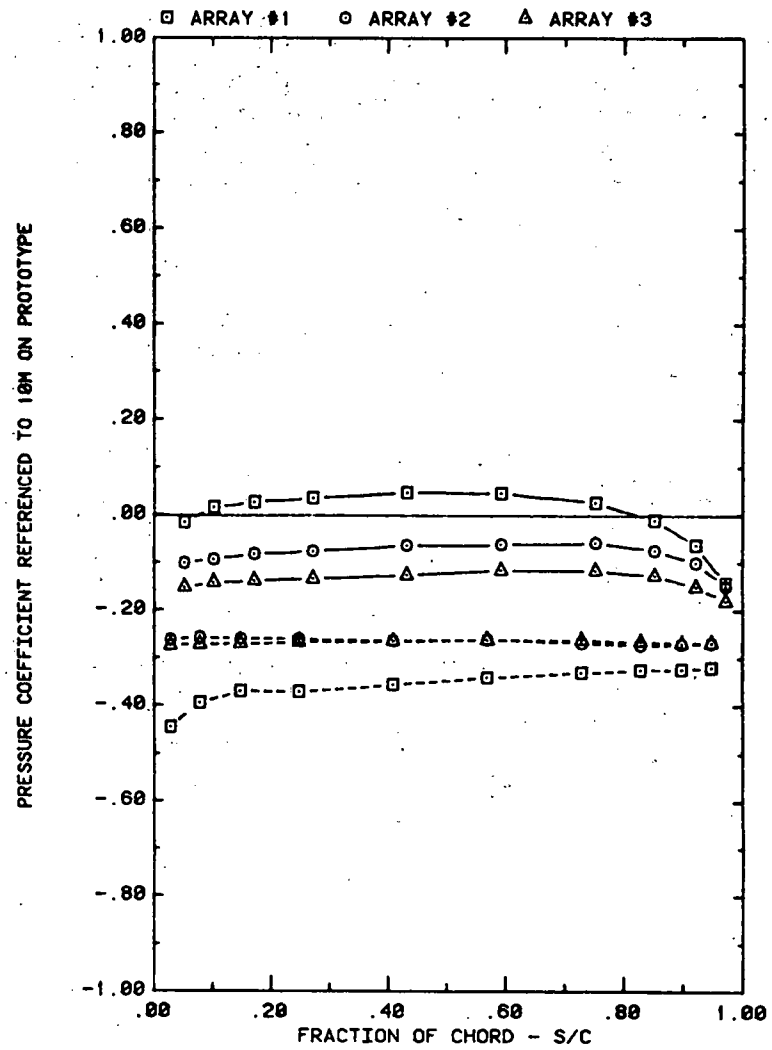

FRONT AND BACK PRESSURES ON ARRAYS #1, 2 & 3 \END PLATE
EFFECT OF ARRAY WITH ALPHA = 145, WIND = 45, X = 2C, FC = 1

Plot 5-3-1. (Continued)

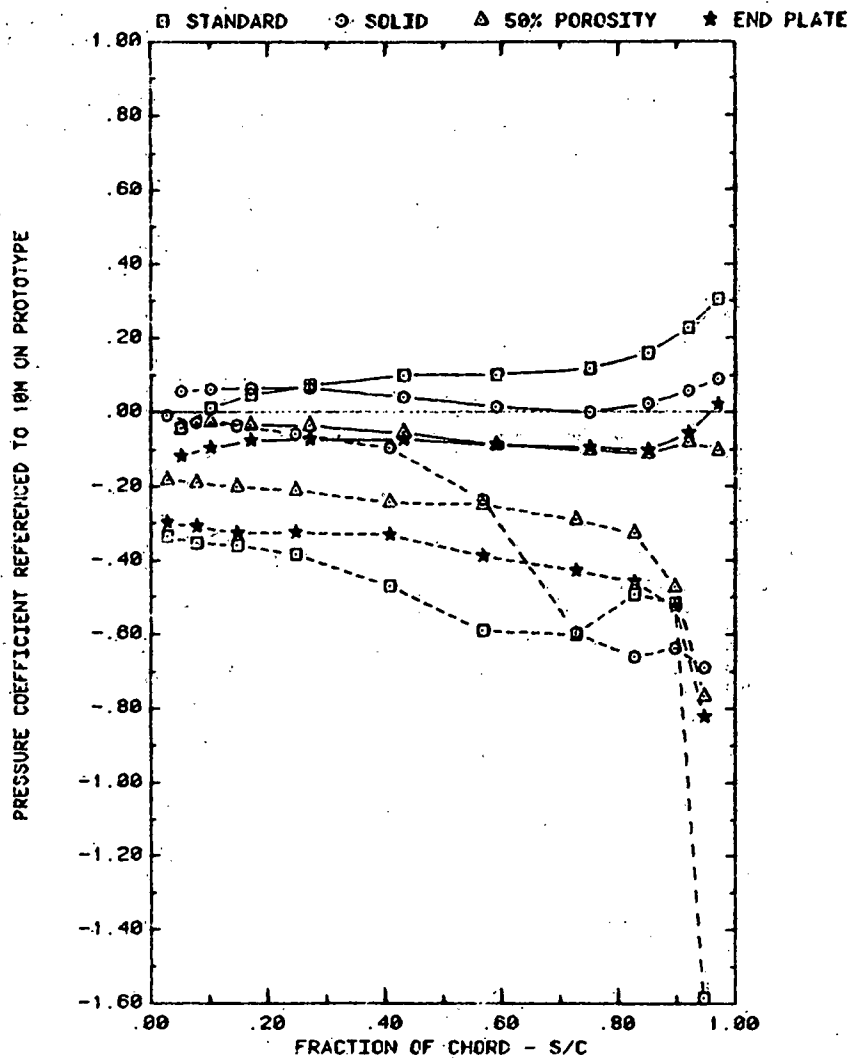

FRONT AND BACK PRESSURES ON ARRAYS; $X = 2C$, WIND = 45
 EFFECT OF EXTENSIONS; ARRAY = 1, ALPHA = 35, FC = 1

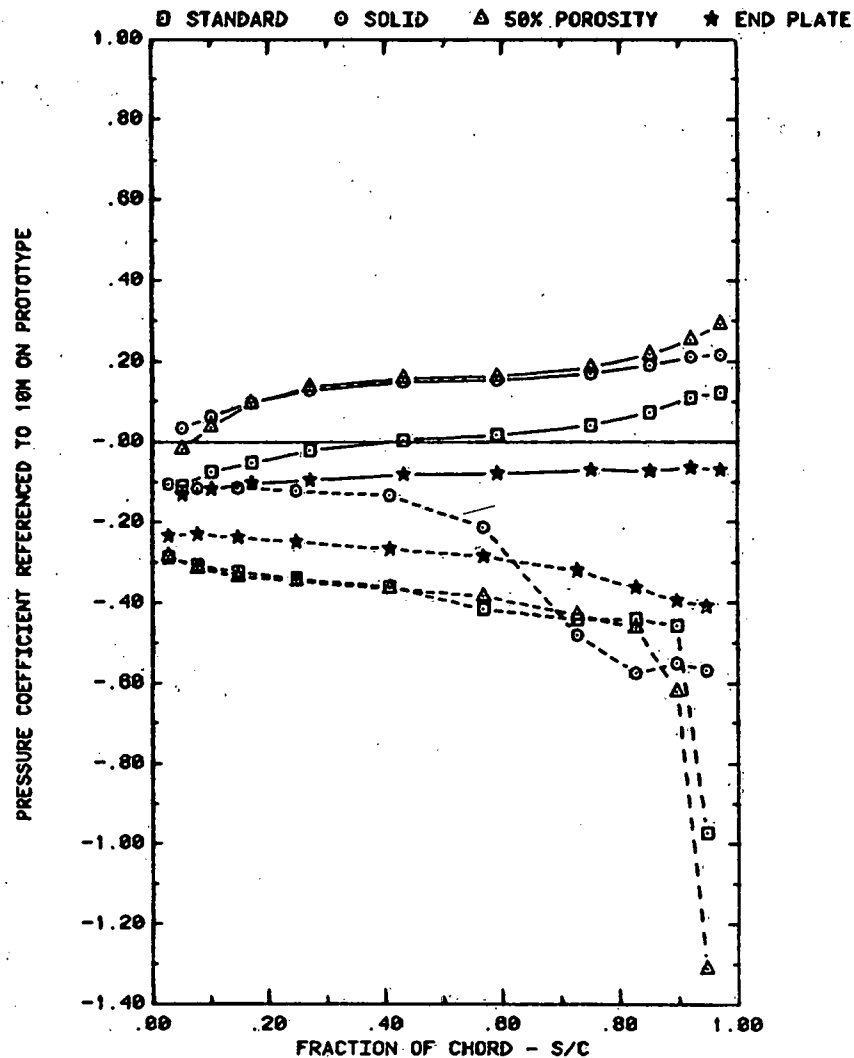

FRONT AND BACK PRESSURES ON ARRAYS; $X = 2C$, WIND = 45
 EFFECT OF EXTENSIONS; ARRAY = 2, ALPHA = 35, FC = 1

Plot 5-3-2. Corner Study, $WD = 45^\circ$, Modified Model with Various Extension
 Effect of Model Configuration

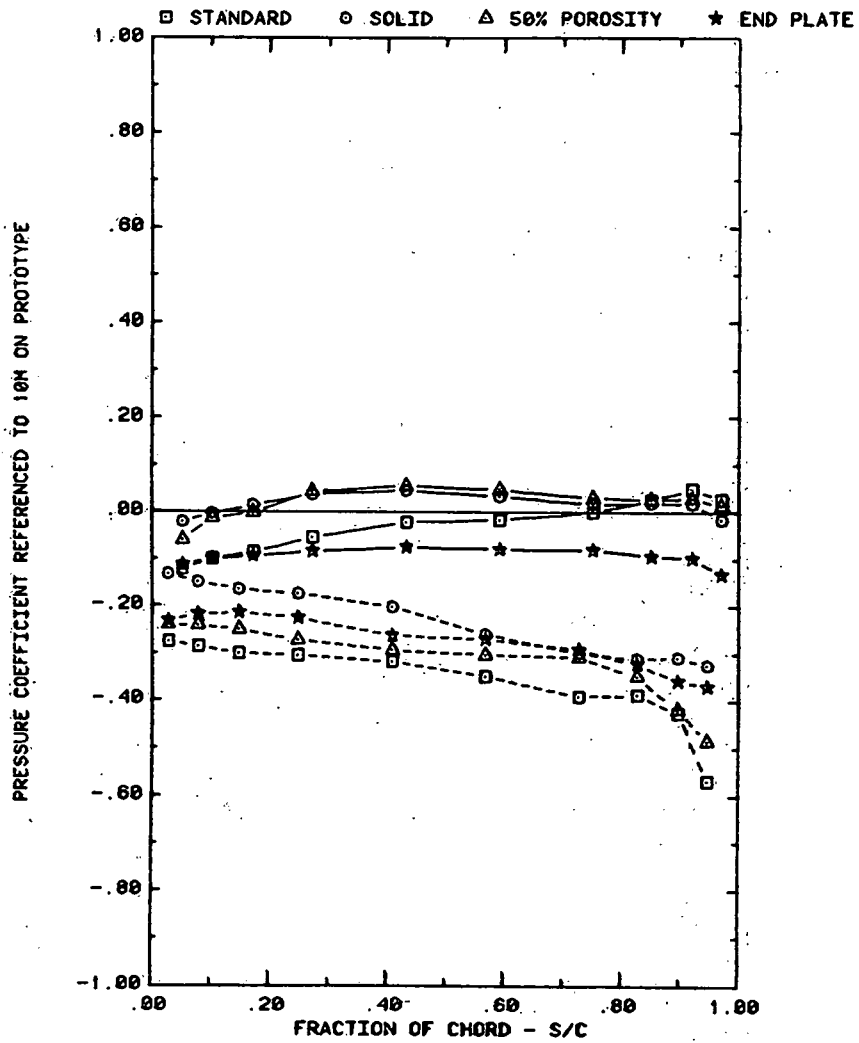

FRONT AND BACK PRESSURES ON ARRAYS; $X = 2C$, WIND = 45
 EFFECT OF EXTENSIONS; ARRAY = 3, ALPHA = 35, FC = 1

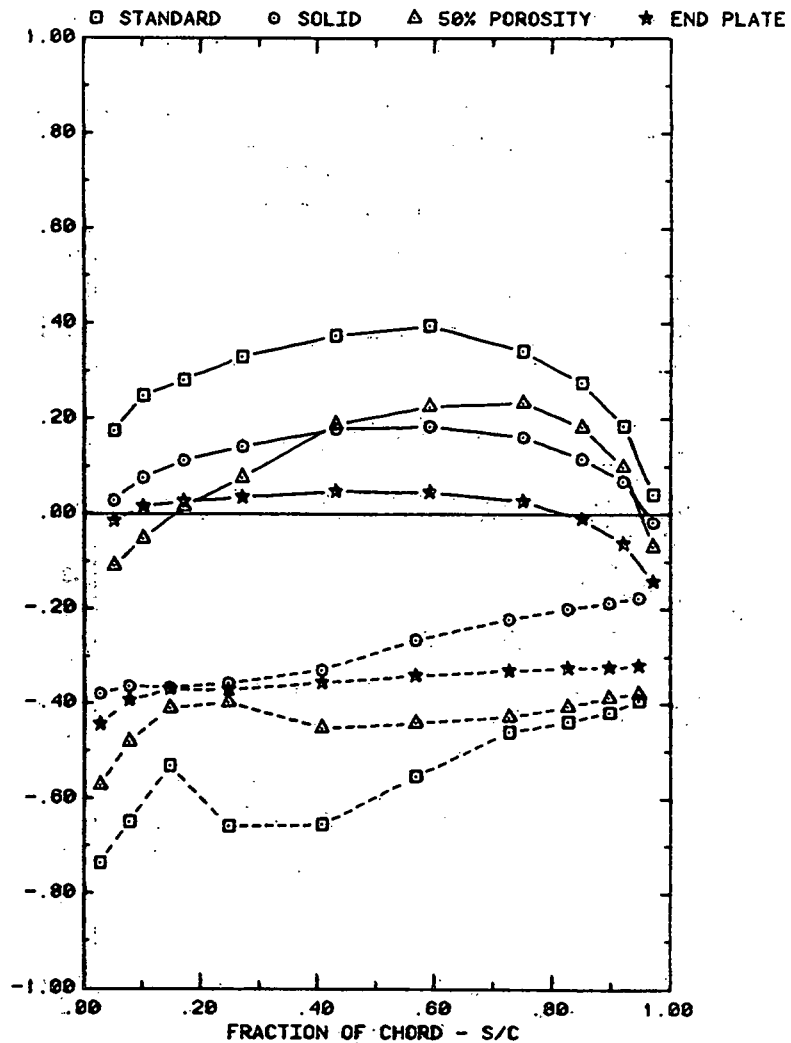

FRONT AND BACK PRESSURES ON ARRAYS; $X = 2C$, WIND = 45
 EFFECT OF EXTENSIONS; ARRAY = 1, ALPHA = 145, FC = 1

Plot 5-3-2. (Continued)

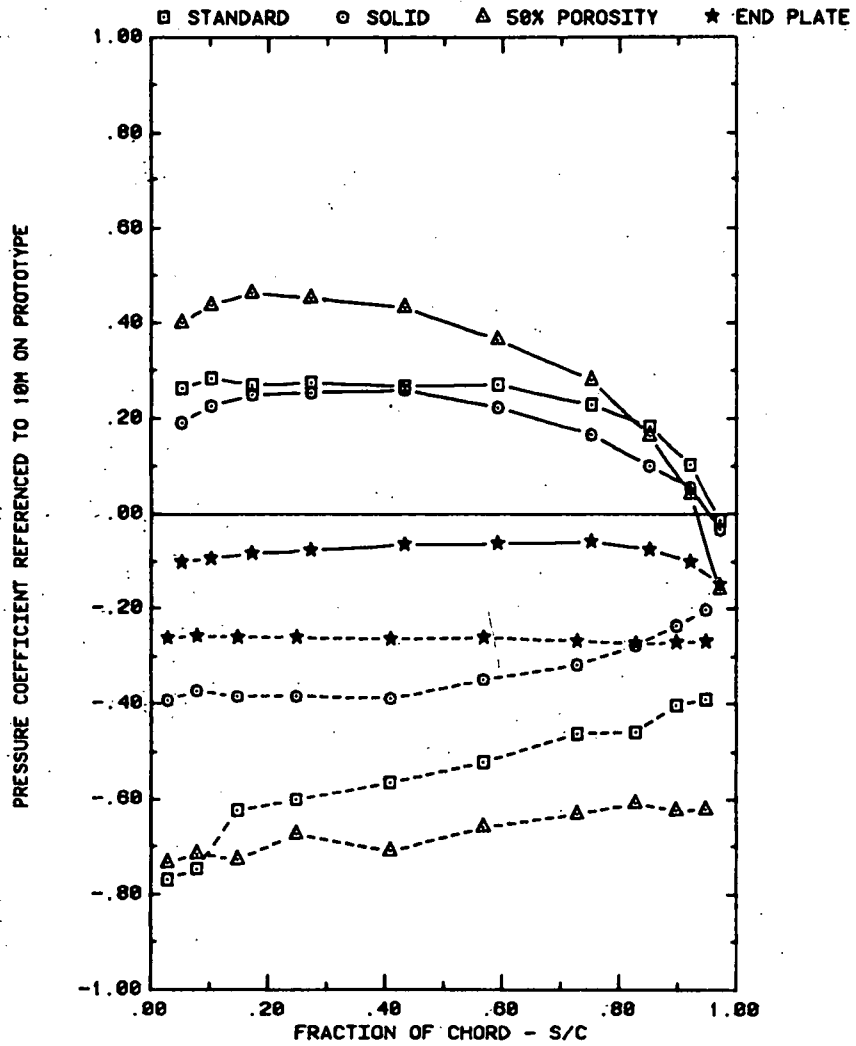

FRONT AND BACK PRESSURES ON ARRAYS; $X = 2C$, WIND = 45
EFFECT OF EXTENSIONS; ARRAY = 2, ALPHA = 145, FC = 1

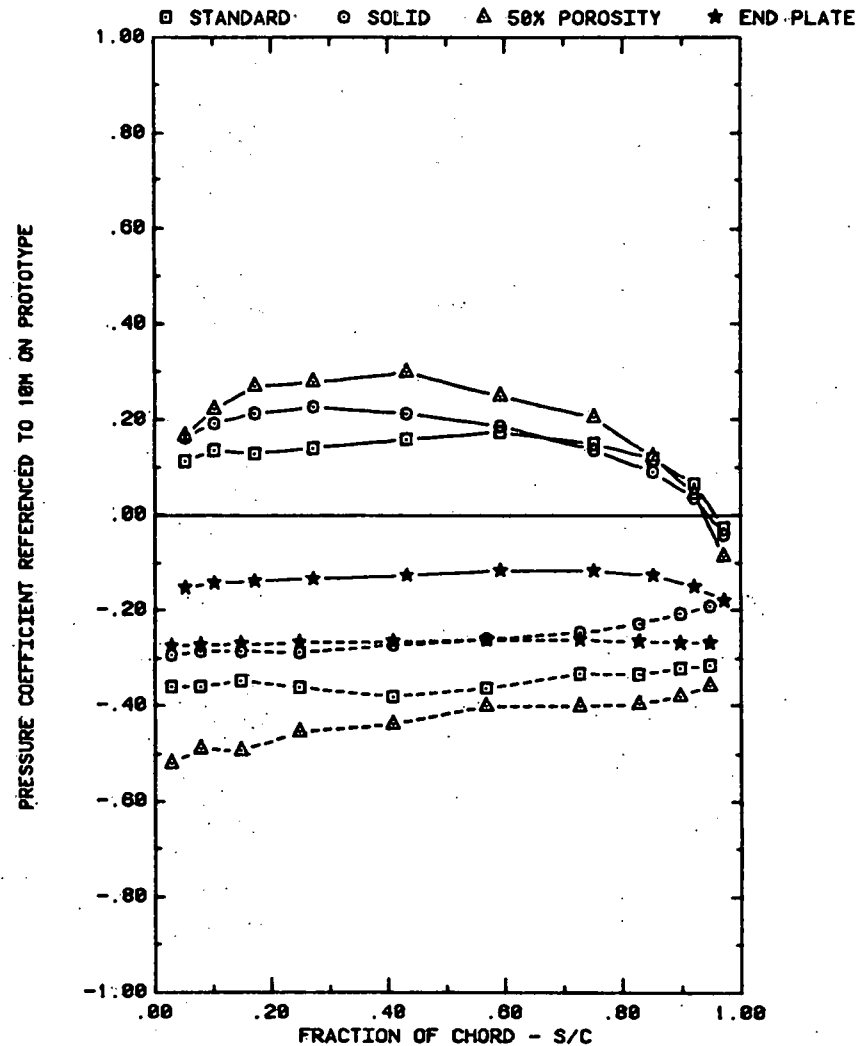

FRONT AND BACK PRESSURES ON ARRAYS; $X = 2C$, WIND = 45
EFFECT OF EXTENSIONS; ARRAY = 3, ALPHA = 145, FC = 1

Plot 5-3-2. (Concluded)