

Wireless Home Automation System Using Zigbee

S. Benjamin Arul

Abstract— Home Automation industry is growing rapidly; this is fuelled by provide supporting systems for the elderly and the disabled, especially those who live alone. Coupled with this, the world population is confirmed to be getting older. Home automation systems must comply with the household standards and convenience of usage. This paper details the overall design of a wireless home automation system (WHAS) which has been built and implemented. The automation centers on recognition of voice commands and uses low-power RF ZigBee wireless communication modules which are relatively cheap. The home automation system is intended to control all lights and electrical appliances in a home or office using voice commands. The system has been tested and verified. The verification tests included voice recognition response test, indoor ZigBee communication test. The tests involved a mix of 10 male and female subjects with different Indian languages. 7 different voice commands were sent by each person. Thus the test involved sending a total of 70 commands and 80.05% of these commands were recognized correctly.

Keywords— Home automation, ZigBee transceivers, voice streaming, HM 2007, voice recognition.

1. INTRODUCTION

The demography of the world population shows a trend that the elderly population worldwide is increasing rapidly as a result of the increase of the average life expectancy of people [1]. Caring for and supporting this growing population is a concern for governments and nations around the globe [2]. Home automation is one of the major growing industries that can change the way people live. Some of these home automation systems target those seeking luxury and sophisticated home automation platforms; others target those with special needs like the elderly and the disabled. The aim of the reported Wireless Home Automation System (WHAS) is to provide those with special needs with a system that can respond to voice commands and control the on/off status of electrical devices, such as lamps, fans, television etc, in the home. The system should be reasonably cheap, easy to configure, and easy to run.



Figure 1: Control Home Security, Monitoring and Automation (SMA)[3].

Author detail

S. Benjamin Arul, M.E., Assistant Professor,

Department of EIE, Jeppiaar Engineering College

benjamin.gjf@gmail.com

There have been several commercial and research projects on smart homes and voice recognition systems. Figure 1 shows an integrated platform for home security, monitoring and automation (SMA) from Control [3]. The system is a 7-inch touch screen that can wirelessly be connected to security alarms and other home appliances. The home automation through this system requires holding and interacting with a large panel which constraints the physical movements of the user [4].

Another popular commercially available system for home automation is from Home Automated Living (HAL) [5]. HAL software taps the power of an existing PC to control the home. It provides speech command interface. A big advantage of this system is it can send commands all over the house using the existing highway of electrical wires inside the home's walls. No new wires means HAL is easy and inexpensive to install. However, most of these products sold in the market are heavily priced and often require significant home make over.

The rest of the paper is organized as follows: Section II provides a system overview. The hardware design is detailed in Section III while the software design is detailed in Section IV. The experimental results are discussed in Section V. The paper concludes by looking at the future research and development work required to make the system more versatile.

The Wireless Home Automation System (WHAS) is an integrated system to facilitate elderly and disabled people with an easy-to-use home automation system that can be fully operated based on speech commands. The system is constructed in a way that is easy to install, configure, run, and maintain. The functional blocks of the overall system are shown in Figure 2.

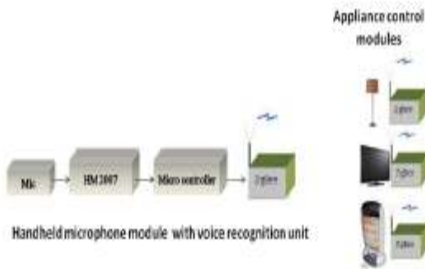

Figure 2: Functional block diagram of the Wireless Home Automation System (WHAS)

The system consists of two modules:

- o Handheld Microphone Module which incorporates a microphone with RF module (ZigBee protocol) and voice recognition unit.
- o Appliance Control Modules with relay controlling circuits.

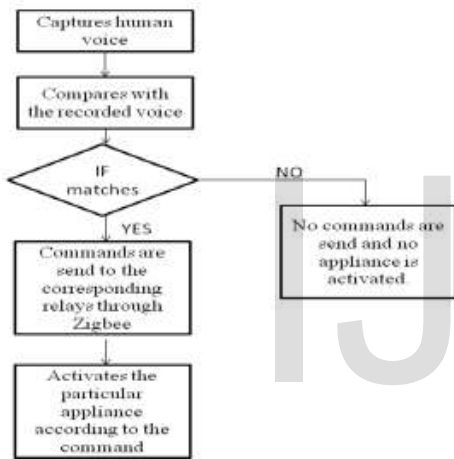

Figure 3: Sequence of activities in Wireless Home Automation System (WHAS)

Figure 3 illustrates the sequence of activities in the WHAS. The voice is captured using a microphone. Upon recognition of the commands, control characters are sent wirelessly to the specified appliance address. Consequently, appliances can be turned ON or OFF or controlled like increasing or decreasing the speed depending on the control characters received.

2. HARDWARE DESIGN

In this section we present the hardware descriptions of the two modules that constitute the WHAS.

2.1 Handheld Microphone Module with voice recognition unit (MM)

The components of the microphone module are shown in Figure 4.

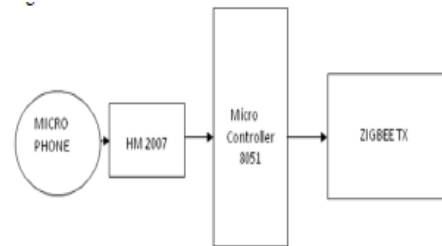

Figure 4: VOICE

2.1 CONTROLLED HOME AUTOMATION HANDHELD MICROPHONE MODULE

The human voice is captured through micro phone. It is matched with the voice previously recorded in HM 2007. If it matches the corresponding signals are sending through Zigbee. Here HM 2007 is the voice recognition unit.

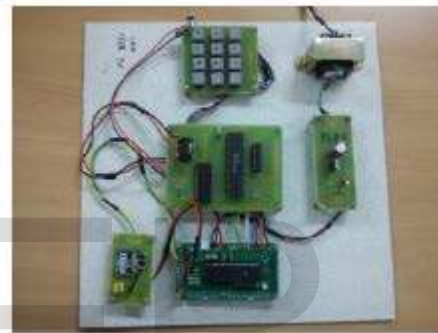

Figure 5: Microphone circuit board with Zigbee module and voice recognition unit.

Figure 5 shows the circuit board for microphone and voice recognition unit. On this board voice is recorded and saved and then recognized whenever a command is given through microphone.

The speech recognition system is a completely assembled and easy to use programmable speech recognition circuit. Programmable, in the sense that you train the words (or vocal utterances) you want the circuit to recognize. This board allows you to experiment with many facets of speech recognition technology. It has 8 bit data out which can be interfaced with any microcontroller for further development. Some of interfacing applications which can be made are controlling home appliances, robotics movements, Speech Assisted technologies, Speech to text translation, and many more.

2.2 Features

- Self-contained stand alone speech recognition circuit

- User programmable
 - Up to 20 word vocabulary of duration two second each
 - Multi-lingual
 - Non-volatile memory back up with 3V battery onboard.
- Will keep the speech recognition data in memory even after power off.
- Easily interfaced to control external circuits & appliances

2.3 Appliance Control Module

Once the speech commands are recognized, control characters are sent to the specified appliance address through ZigBee communication protocol. Each appliance that has to be controlled has a relay controlling circuit.

The components of appliance control module are shown in the figure 6.

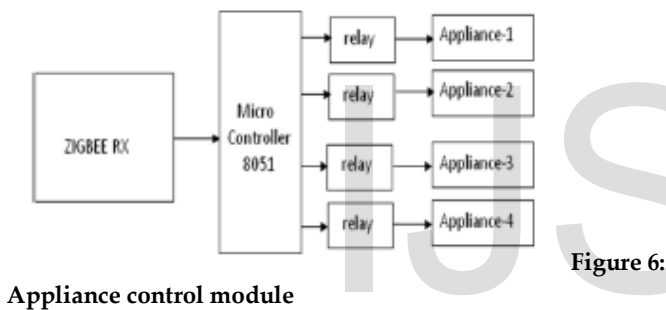

Figure 6:



Figure 7: Appliance control module board with zigbee module



Figure 8: Fabricated relay control unit

Control characters corresponding to the recognized commands are then sent serially from the central controller module to the appliance control modules that are connected to the home appliances.

3. SOFTWARE DESIGN

Software design includes transmission receiving, and voice recognition.

3.1 Voice Recognition Application

The voice recognition application is implemented through HM 2007 IC. The main program for this system is written by using the c programming language. The schematic diagram for this system which consists of all the components was designed by using the protease ISIS 7 professional editions. The main program was developed in the Kiel Integrated Development Environment by using the C programming language. The .c program was converted into .HEX file in this IDE and dumped into the ROM part of the AT89c51 micro controller.

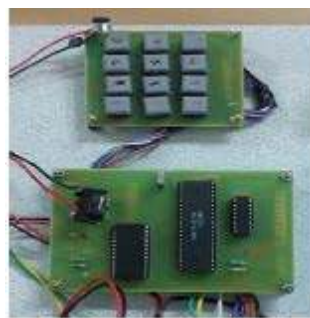

Figure 9: Voice recognition unit

Voice recognition unit using HM 2007 is shown in the figure 9. It consists of HM 2007 IC, SRAM and keypad. In this unit voice is recorded and then recognized.

The speech recognition system will process the signal and store the command in a static RAM IC. Figure 10 shows the schematic of the speech recognition board.

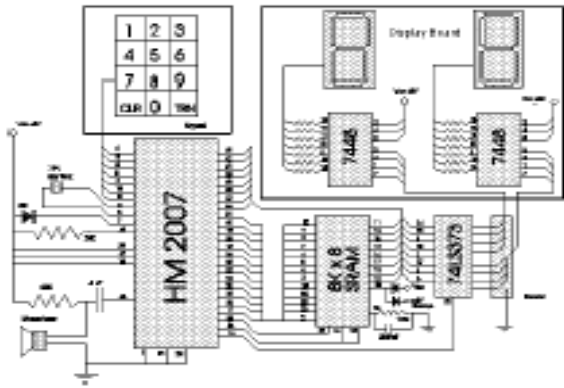

Figure 10: Schematic of speech recognition board

The HM2007 is a CMOS voice recognition LSI (Large Scale Integration) circuit. The chip contains an analog front end, voice analysis, regulation, and system control functions. The chip may be used in a stand alone or CPU connected.

Features:

- Single chip voice recognition CMOS LSI • Speaker dependent
- External RAM support
- Maximum 40 word recognition (.96 second)
- Maximum word length 1.92 seconds (20 word)
- Microphone support
- Manual and CPU modes available
- Response time less than 300 milliseconds
- 5V power supply

3.2 ZigBee RF communication

Zigbee protocol is the communication protocol that’s used in this system. Zigbee offers 250 kbps as maximum baud rate, however, 115200 bps was used for sending and receiving as this was the highest speed that the UART of the microcontroller could be programmed to operate at. For each byte transmitted, there is a start and stop bit. Hence the actual baud rate is :

$$\text{Actual baud rate} = \text{configured baud rate} * (8/10)$$

$$\text{Actual baud rate} = 115200 * (8/10) = 92160$$

ZigBee is a low-power wireless communications technology designed for monitoring and control of devices. Based on the

802.15.4 standard, ZigBee technology provides a robust and reliable solution in noisy radio frequency (RF) environments. ZigBee features include energy detection, clear channel assessment and channel agility help devices pick the best possible channel and avoid other wireless networks such as Wi-Fi® while message acknowledgement ensures that the data was delivered to its destination. Multiple levels of security ensure that the network and data remain intact and secure. One of ZigBee's key features is its ability to cover large areas with routers. This feature helps differentiate ZigBee from other technologies. Mesh networking extends the range of the network through routing, while self healing increases the reliability of the network by re-routing a message in case of a node failure.

ZigBee technology supports two features sets (ZigBee Feature Set and ZigBee Pro Feature Set) which focus on specific markets. The "ZigBee" feature set targets home and light commercial environments that are designed for simpler plug and forget networks.

The "ZigBee Pro" feature set includes those features and enhancements in the ZigBee feature set and adds elements designed for larger, more complex networks, such as centralized data collection, network scalability, automated address management and group addressing. Free scale provides all the building blocks needed for both ZigBee and ZigBee Pro feature sets including hardware, software, tools and reference designs. The development hardware and reference designs provide developers with the tools needed to easily and quickly implement these building blocks. One solution, one provider—built, tested, compatible and ready for integration.

ZigBee Key Features:

- Low Power
- Robust
- Mesh Networking
- Interoperability

4. EXPERIMENTAL RESULTS AND DISCUSSIONS

The prototype of the system has been fabricated and tested. Figure 11 shows the microphone module. Figure 12 shows the appliances control module.

The graph in Figure 10 and the data in Table I show the response of the speech recognition application to spoken commands. The tests involved 10 subjects; the trails were conducted with people with different Indian languages. The test subjects were a mix of male and female and 7 different voice commands were sent by each person. Thus the test involved sending a total of 70 commands. 80.05% of these commands were recognized correctly. When a command is not recognized correctly, the software ignores the command and

does not transmit any signals to the device control modules. The accuracy of the recognition can be affected by background noise, speed of the speaker, and the clarity of the spoken accent. These factors need to be studied further in more details by conducting more tests. The system was tested in an apartment and performed well up to 40m. With a clear line-of-sight transmission (such as in a wide open gymnasium) the reception was accurate up to 80m.

3.3 SPEECH RECOGNITION RESPONSE

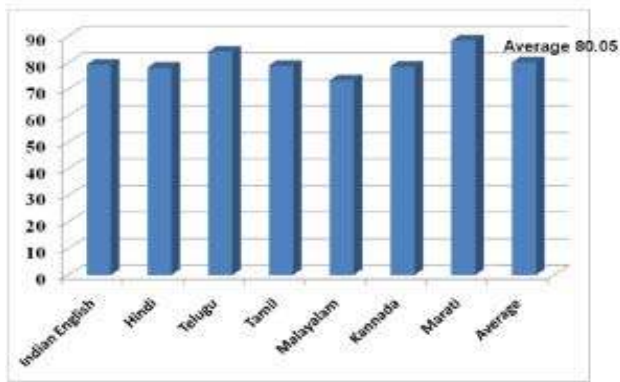

Figure 10: Results of voice recognition experiments showing percentage of correct recognition for different ethnicity accent

Additional tests are being planned involving a bigger variety of commands

TABLE I

RESULTS OF VOICE COMMAND RECOGNITION TESTS PERCENTAGE OF COMMANDS CORRECTLY RECOGNISED VI.

Category	Indian English	Hindi	Telugu	Tamil	Malayalam	Kannada	Marathi
Person 1	68	85.7	88.6	70.3	67.7	75.8	96.7
Person 2	86	80	85	77	70	81.8	88
Person 3	67	88	80	80	74	85	85
Person 4	90	77	90	77	78.6	82	90
Person 5	85	60	77	90	76	68	82
Average	79.2	78.1	84.1	78.86	73.3	78.5	88.3

5. CONCLUSIONS AND FUTURE WORK

A home automation system based on voice recognition was built and implemented. The system is target at elderly and

disabled people. The prototype developed can control electrical devices in a home or office. The system implements voice recognition unit using HM 2007. The system implements the wireless network using ZigBee RF modules for their efficiency and low power consumption. The preliminary test results are promising.

5.1. Future work will entail:

- o Adding confirmation commands to the voice recognition system.
- o Integrating variable control functions to improve the system versatility such as providing control commands other than ON/OFF commands. For example "Increase Temperature", "Dim Lights" etc.
- o Integration of GSM or mobile server to operate from a distance.
- o Design and integration of an online home control panel.

REFERENCES

[1] T. Birtley, (2010) Japan debates care for elderly. [Cited 21/09/2010]. Available: <http://www.youtube.com/watch?v=C0UTqfigSec>

[2]. Population Division, DESA, United Nations. (2009). World Population Ageing: Annual report 2009. [29/07/2010]. Available: http://www.un.org/esa/population/publications/WPA2009/WPA2009_WorkingPaper.pdf

[3].(2010) uControl Home security system website. [Cited 2010 14th Oct]. Available: <http://www.itechnews.net/2008/05/20/ucontrol-home-security-system/> [4]. R. Gadalla, "Voice Recognition System for Massey University Smarthouse," M. Eng thesis, Massey University, Auckland, New Zealand, 2006.

[5]. (2010) Home Automated Living website. [Cited 2010 14th Oct]. Available: <http://www.homeautomatedliving.com/default.htm> [6]. L. R. Rabiner and R. W. Schafer, *Digital Processing of Speech Signals*, New Jersey, US: Prentice Hall Inc, 1978. [7]. "XBee-2.5-Manual," ZigBee RF communication protocol. (2008). Minnetonka: Digi International Inc. [8]. B. Yukesekkaya, A. A. Kayalar, M. B. Tosun, M. K. Ozcan, and A. Z. Alkar, "A GSM, Internet and Speech Controlled Wireless Interactive Home Automation System," *IEEE Transactions on Consumer Electronics*, vol. 52, pp. 837-843, August 2006. [9]. F. J. Owens, *Signal Processing of Speech*, New York, US: McGraw-Hill Inc, 1993. [10]. *Voice Recoder Refrence Design (AN 278)*, Silicon Laboratories, 2006.

[11]. D. Brunelli, M. Maggiorotti, L. Benini, and F. L. Bellifemine, "Analysis of Audio Streaming Capapbility of

IJSER