

# Wireless Powered Communication: Opportunities and Challenges

Rui Zhang

ECE Department, National University of Singapore

ERC@SKKU  
September 12, 2014

# Wireless Communications in the Age of “Energism”



Wireless power transfer

## Green communications

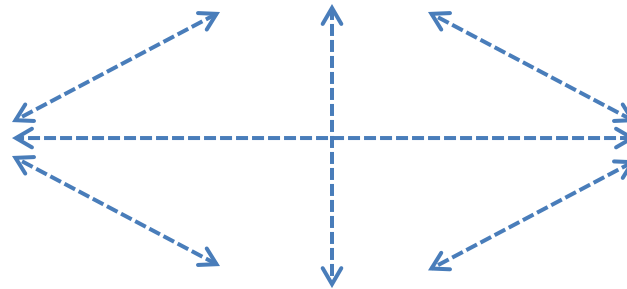

Energy harvesting

## Smart grid

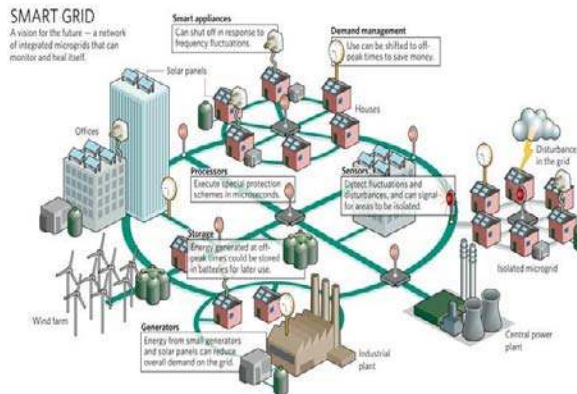

# Wireless Powered Communication: Network Architectures

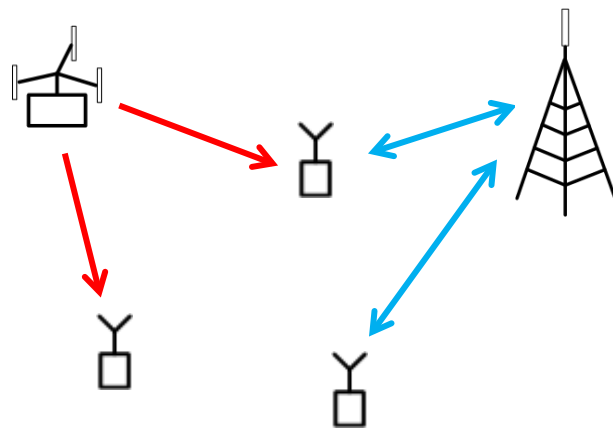
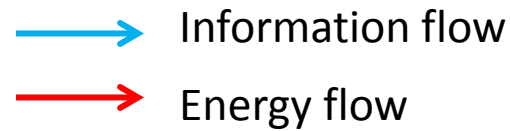

Separate energy & info transmitters

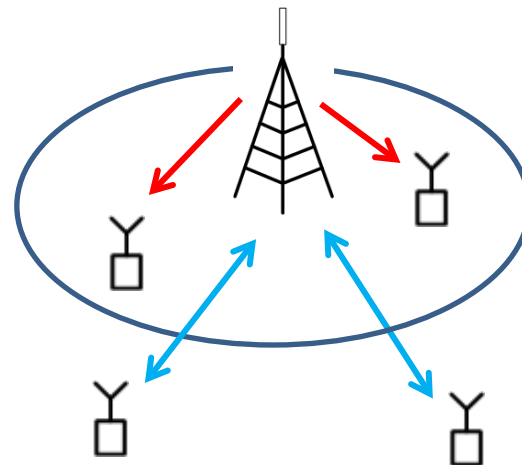

Separate energy & info receivers

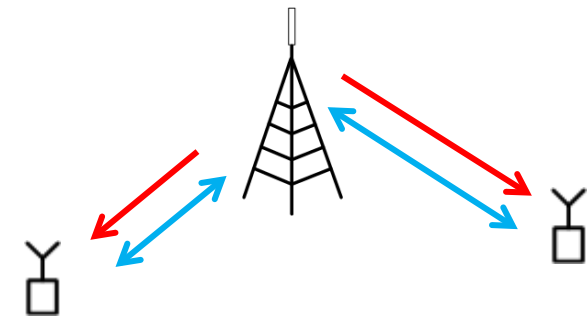

Co-located energy & info receiver

## A Generic Model

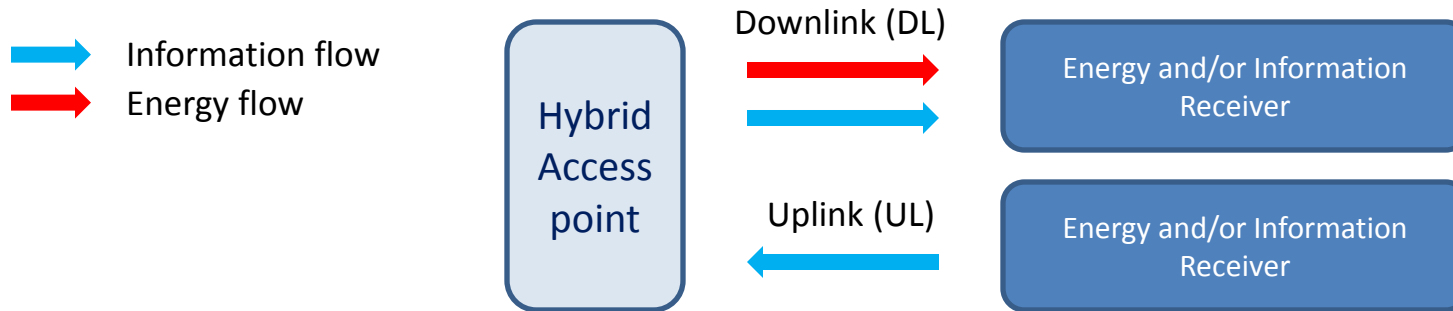

### □ Three “Canonical” Models/Modes [1], [2]

- Wireless Power Transfer (**WPT**) in DL
- Wireless Powered Communication Network (**WPCN**): DL WPT and UL wireless information transmission (WIT)
- Simultaneous wireless information and power transfer (**SWIPT**): DL WPT and WIT at the same time

## Operating Mode 1: WPT

- ❑ Wireless power transfer (WPT)
  - Only power transfer in DL
  - **Dedicated energy source and fully controllable** (unlike ambient RF and other environmental energy harvesting)
  - Application: mobile device and sensor charging, etc.
  - Technologies available (to be detailed later)
    - ✓ Inductive coupling
    - ✓ Coupled magnetic resonance
    - ✓ **EM radiation**

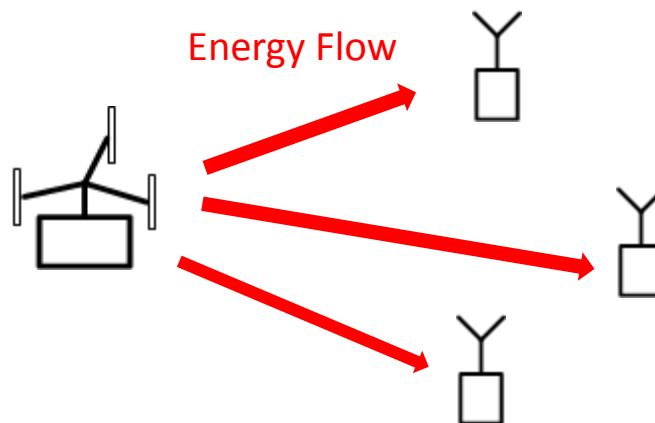

## Operating Mode 2: WPCN

- ❑ Wireless powered communication network (WPCN) [3]
  - DL: wireless power transfer
  - UL: Information transfer using harvested energy
  - Applications: sensor network charging and info collection, RFID, etc.
  - Power consumption at the energy receiver
    - ✓ Sensing and info processing
    - ✓ UL info transmission

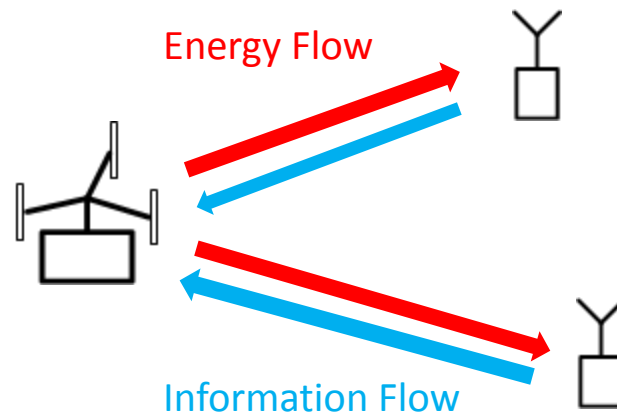

## Operating Mode 3: SWIPT

- ❑ Simultaneous wireless information and power transfer (SWIPT) [2]
  - Info & energy transmit simultaneously in DL
  - Share same signal power and bandwidth
  - Applications: heterogeneous EH and ID receivers, self-sustainable receiver
  - **Rate-and-energy tradeoff**
  - Separate or co-located ID and EH receivers

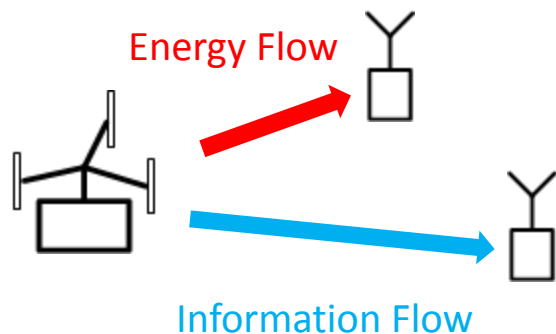

SWIPT with separate ID and EH receivers



SWIPT with co-located ID and EH receivers

# Example Applications [1]

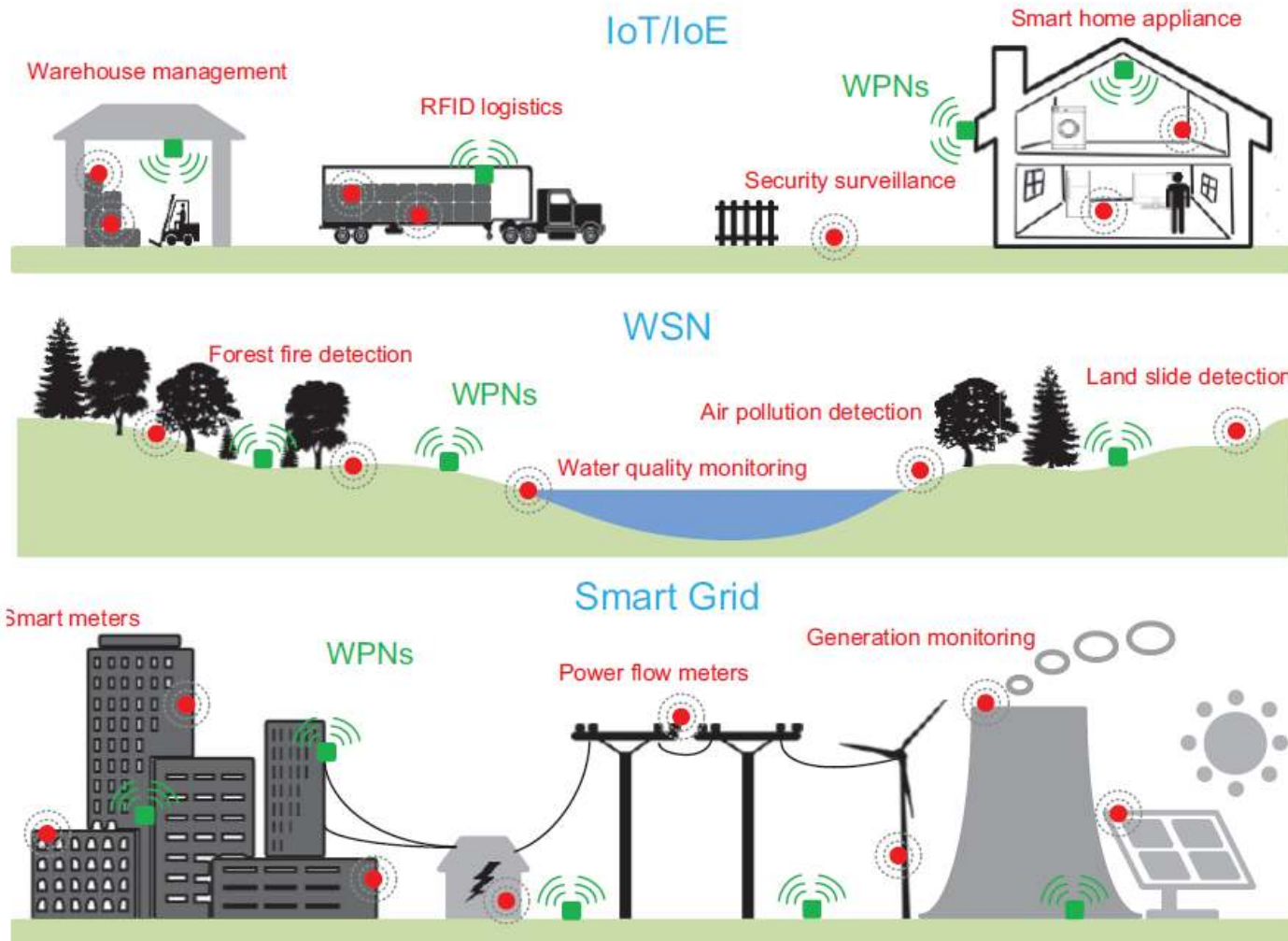



# Agenda

- ❑ Part I: Wireless Power: History and State-of-the-Art
  
- ❑ Part II: Overview of Wireless Powered Communications
  
- ❑ Conclusion and Future Work Direction

## Microwave Enabled Wireless Power Transfer: Nikola Tesla and his Wardenclyffe Project in early 1900

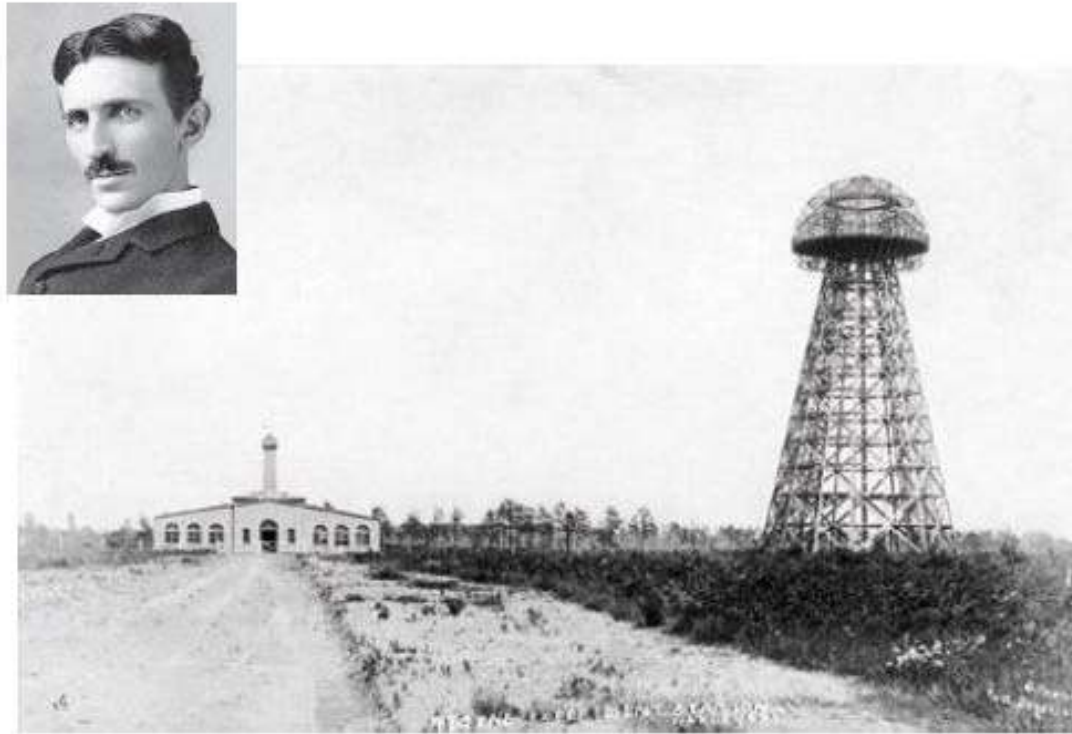

150 KHz and 300 kW. Unsuccessful and never put into practical use.

## The Invention of “Rectenna” for Microwave Power Transmission: the Microwave Powered Helicopter by William C. Brown in 1960s

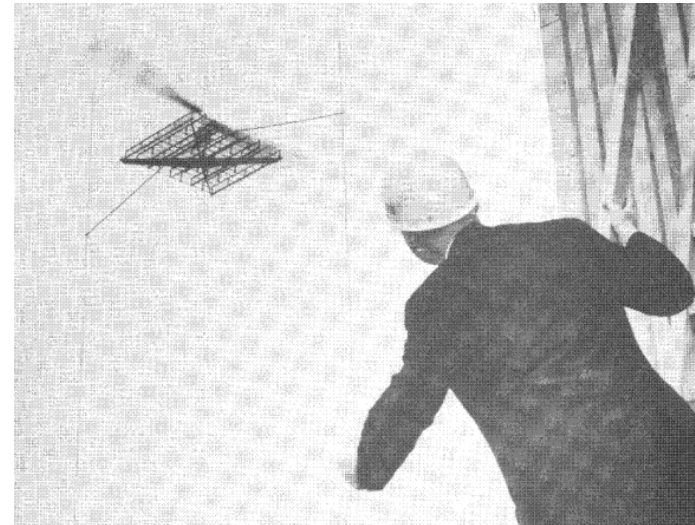
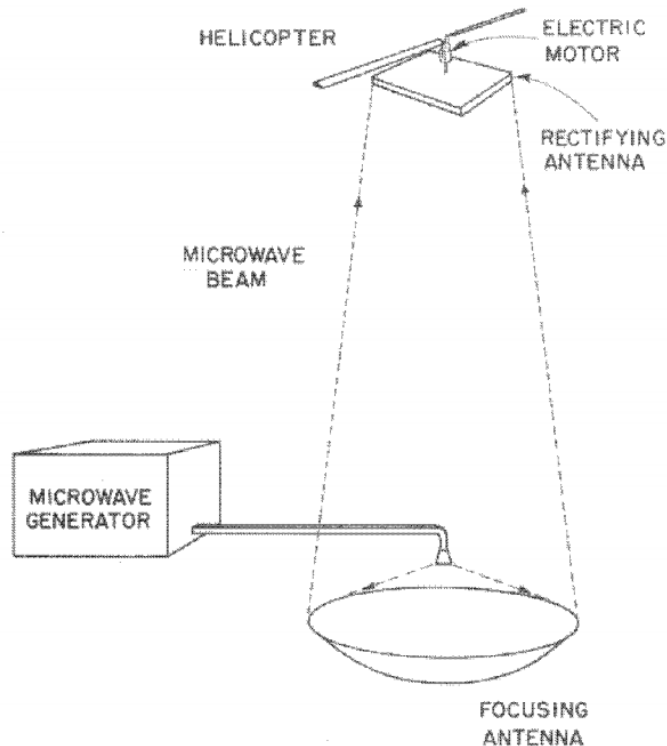

2.45 GHz and less than 1kW. Overall 26% transfer efficiency at 7.6 meters high.

## Solar Satellite with Microwave Power Transmission (1970s-current)

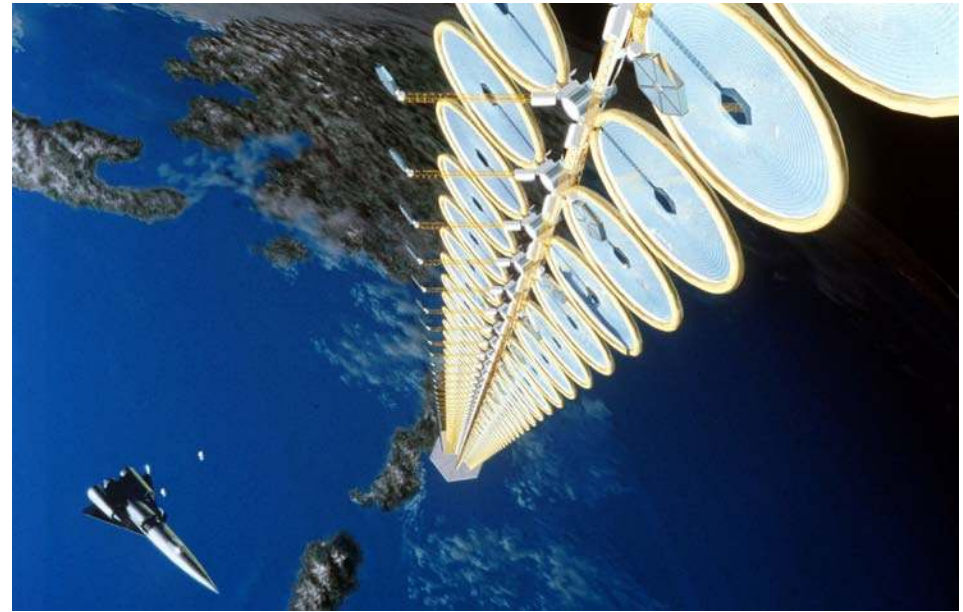
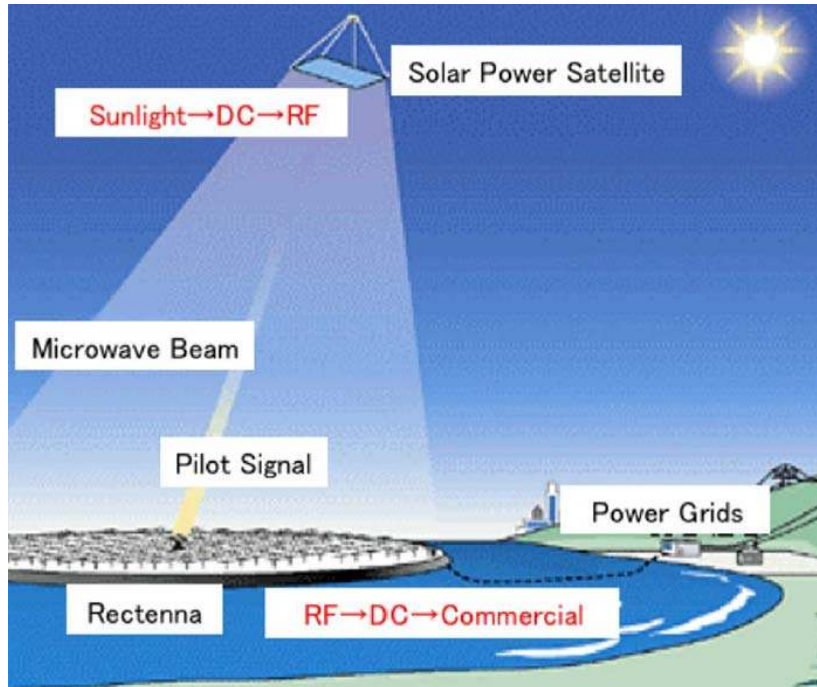

NASA Sun Tower

Target at GW-level power transfer with more than 50% efficiency

## NASA's Wireless Power Transfer Project Using Laser Beam

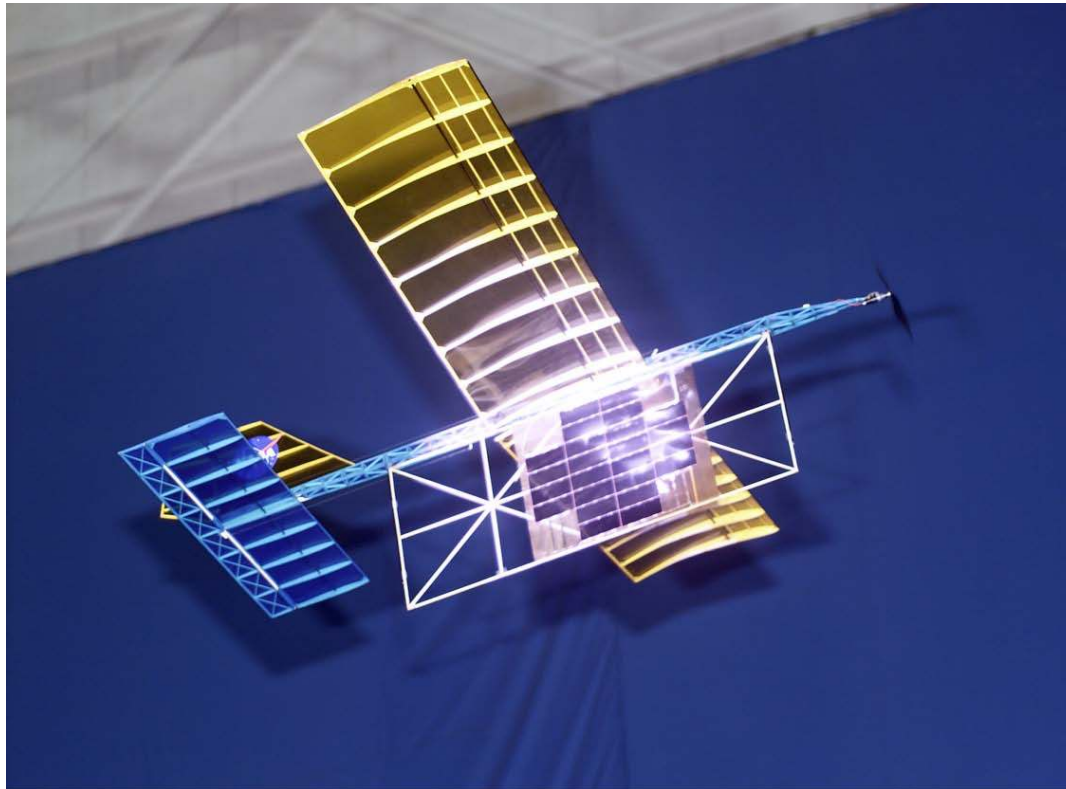

NASA Dryden Flight Research Center Photo Collection  
<http://www.dfrc.nasa.gov/Gallery/Photo/index.html>  
NASA Photo: ED03-0249-18 Date: September 18, 2003 Photo By: Tom Tschida

With a laser beam centered on its panel of photovoltaic cells, a model plane makes the first flight of an aircraft powered by a laser beam inside a building at NASA Marshall.

# Induction Coupling Enabled Wireless Power Transfer: Radio Frequency Identification (RFID) in 1970s

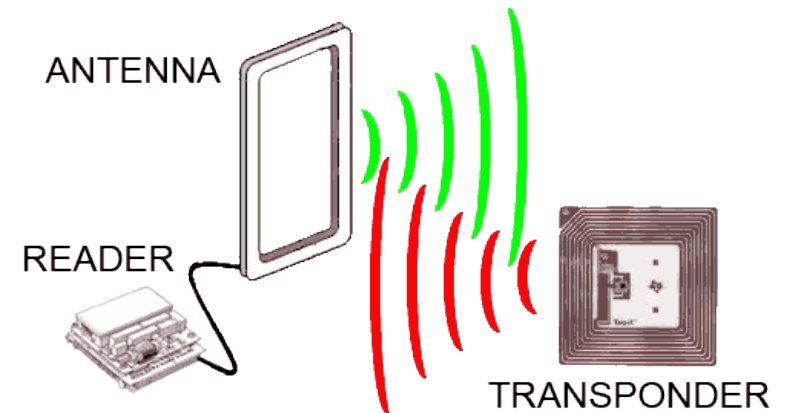

- ❑ Now some RFID tags can also be powered by harvesting RF energy transmitted by the readers (e.g. Intel WISP tags)

## Wireless Power Transfer via Magnetic Resonant Coupling in 2000s

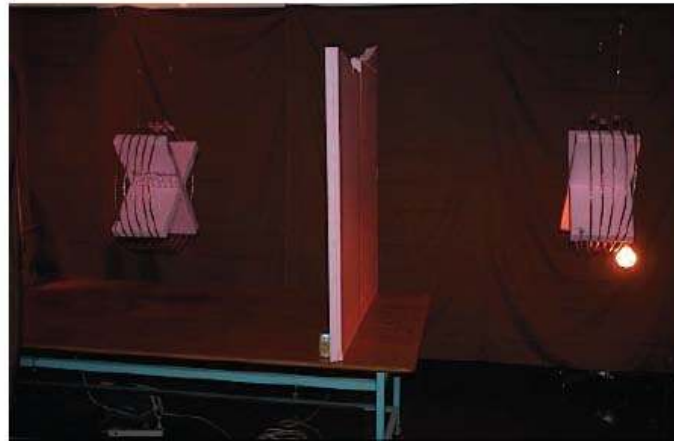

Demonstration of magnetic coupling to power light bulb (Intel Corp.) and charge mobile phones (Witricity Corp.)

# Wireless RF Power Transfer via Electromagnetic Radiation

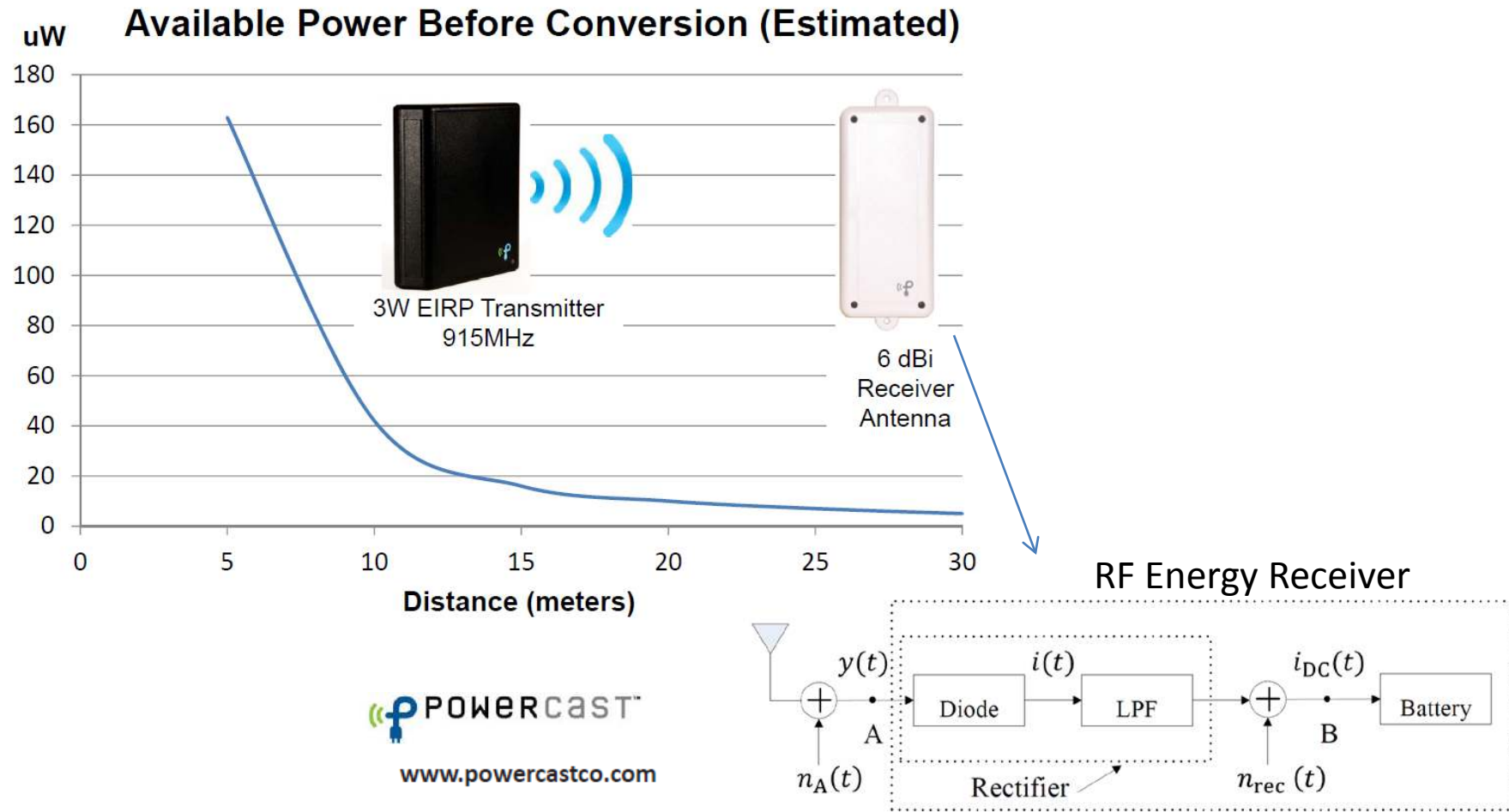



## Wireless Power Transfer: State-of-the-Art Technology

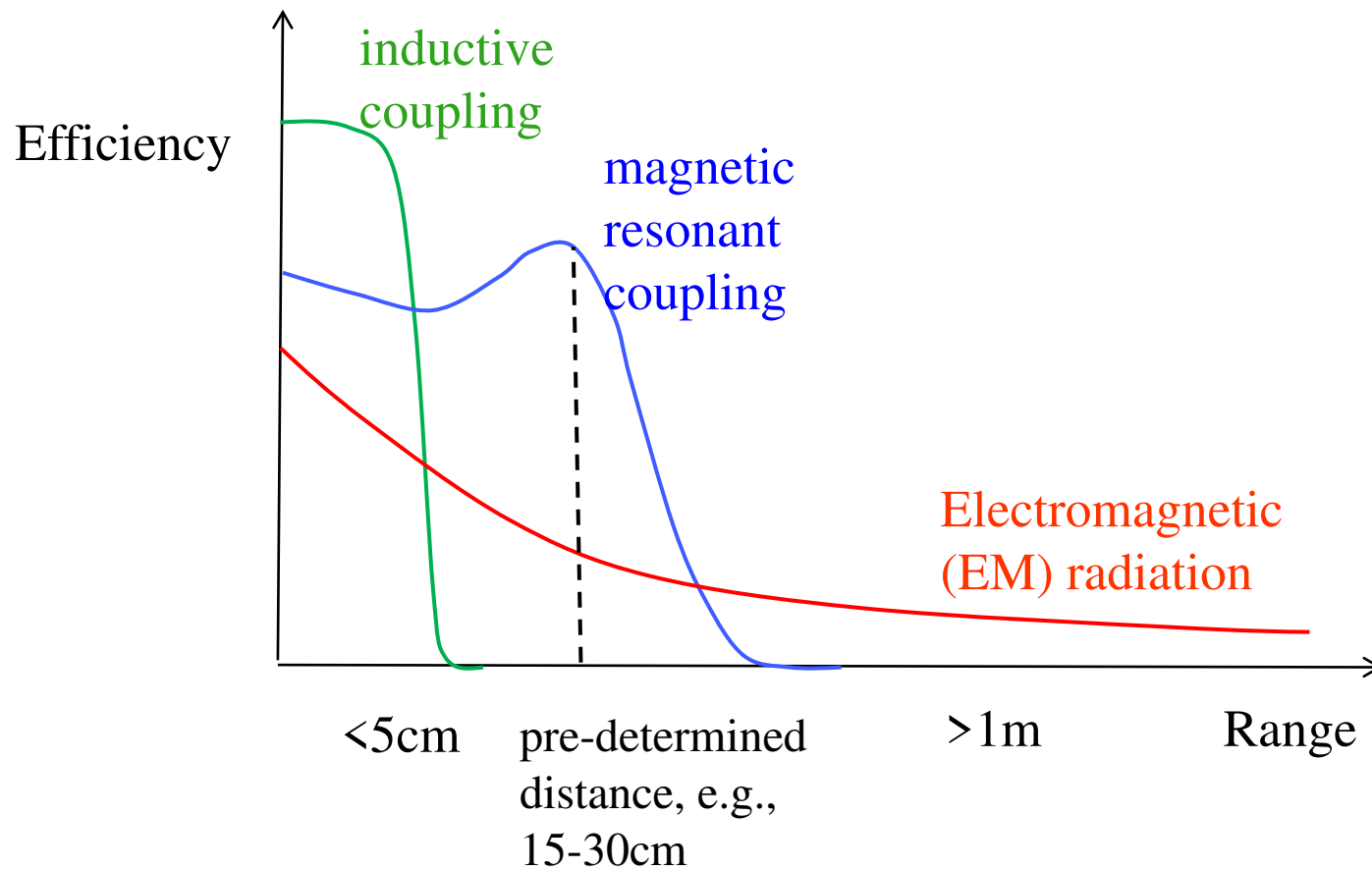

## Summary of performance

		Strength	Efficiency	Distance	Multicast	Mobility	Safety
Inductive Coupling		Very high	Very high	Very short	Yes	No	Magnetic
Magnetic Resonant Coupling		High	High	Short	Difficult	No	Safe
EM Radiation	Omnidirectional	Low	Low	Long	Yes	Yes	Safe
	Unidirectional (microwave/laser)	High	High	Very long (LOS)	No	No	EM

# Application Examples

## Inductive Coupling



The Qi wireless mobile device charging Standard



Electric tooth brush

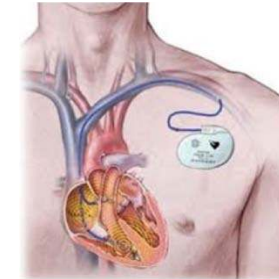

Wireless powered medical implants

## Magnetic Resonant Coupling



Qualcomm eZone wireless charging



Qualcomm Halo electric vehicle powered by charging pad



Haier wireless powered HDTV

## EM Radiation



Intel WISP RFID tags harvest energy from RF radiation



Powercast RF harvesting circuit for sensor networks



The SHARP unmanned plane receives energy beamed from the ground

# Agenda

- ❑ Part I: Wireless Power: History and State-of-the-Art
- ❑ Part II: Overview of Wireless Powered Communications
- ❑ Conclusion and Future Work Direction

## Outline of Part II

- ❑ Microwave Enabled Wireless Power Transfer (**WPT**)
  - Energy receiver structure
  - **Energy beamforming** in MIMO channel
  
- ❑ Wireless Powered Communication Network (**WPCN**)
  - Harvest-then-transmit protocol
  - **Doubly near-far problem**
  
- ❑ Simultaneous Wireless Information and Power Transfer (**SWIPT**)
  - SWIPT receiver structures
  - **Rate-energy tradeoff**

## Point-to-Point Wireless Power Transfer: Channel Model [4]

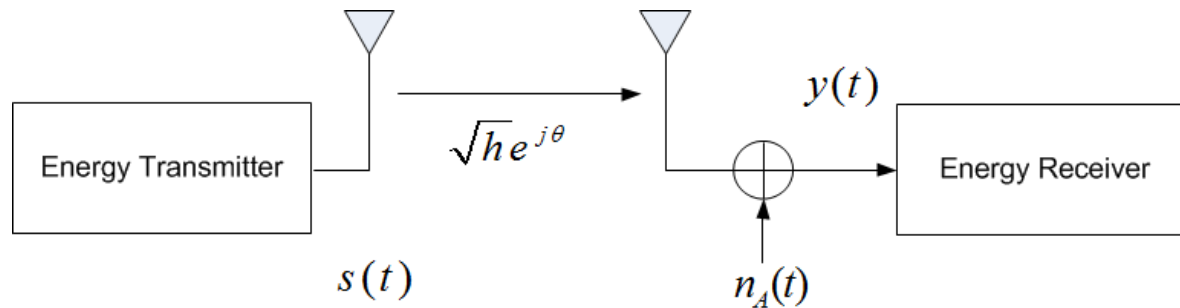

□ Baseband signal:  $x(t) = A(t)e^{j\phi(t)}$  with  $E[|x(t)|^2] = 1$

□ Transmitted RF signal:  $s(t) = \sqrt{2P}\Re\{x(t)e^{j2\pi ft}\}$

□ Complex channel:  $\tilde{h} = \sqrt{h}e^{j\theta}$

□ Antenna noise: complex Gaussian

$$n_A(t) = \sqrt{2}\Re\{\tilde{n}_A(t)e^{j2\pi ft}\} = \sqrt{2}[n_I(t)\cos(2\pi ft) + n_Q(t)\sin(2\pi ft)]$$

□ Received signal:

$$y(t) = \sqrt{2}\Re\left\{\sqrt{hP}x(t)e^{j2\pi ft+\theta} + \tilde{n}_A(t)e^{j2\pi ft}\right\} \triangleq \sqrt{2}\mu_Y(t)\cos(2\pi ft + \phi_Y(t))$$

## Modulated vs. Unmodulated Energy Signal

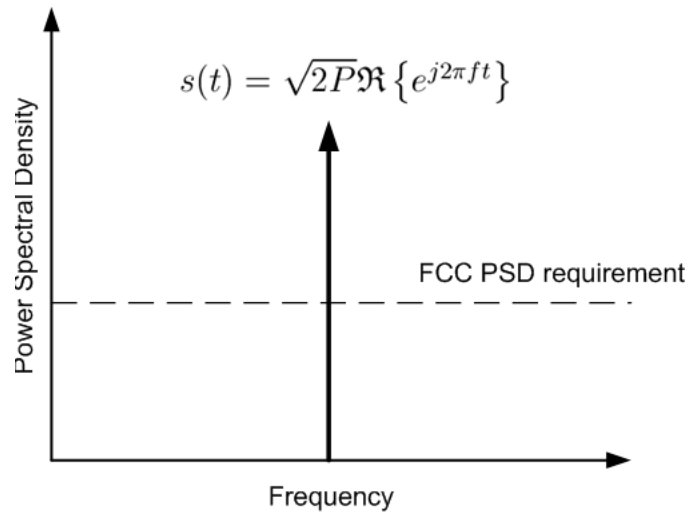

PSD of unmodulated energy signal

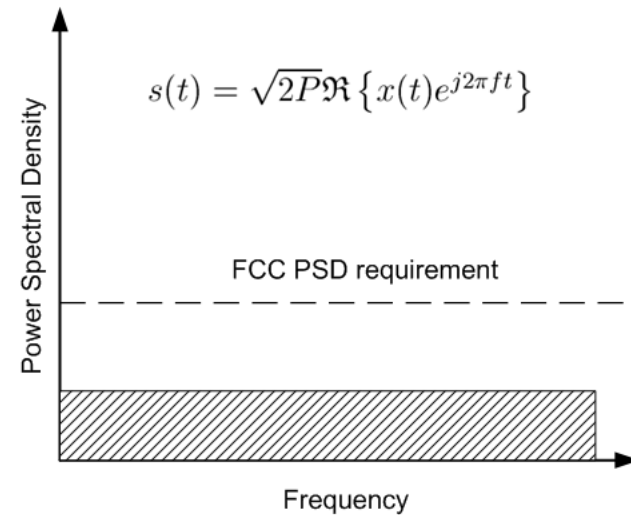

PSD of modulated energy signal

Use **pseudo-random** modulated energy signal to avoid the “spike” in the power spectral density (PSD) caused by constant unmodulated energy signal

## Wireless Power Transfer: Receiver Structure (1)

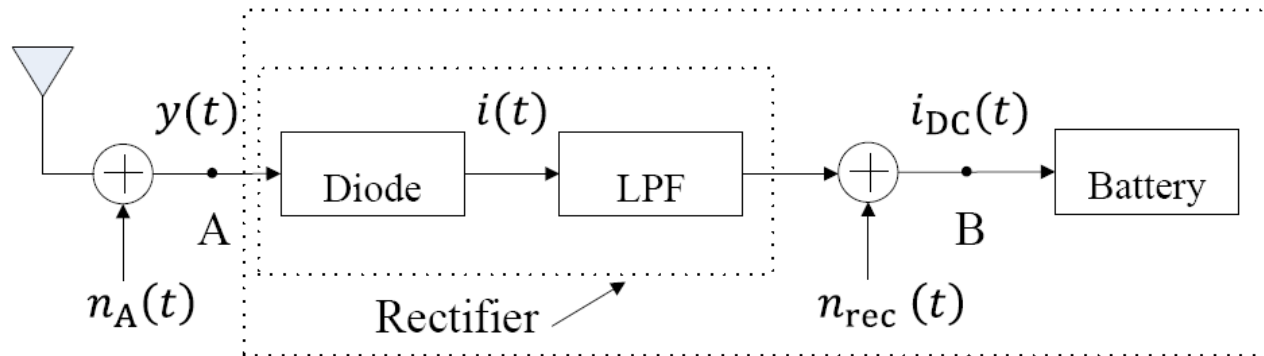

The received RF signal  $y(t)$  is converted into a DC signal  $i_{DC}(t)$  by a *rectifier*

□ Diode output:

$$\begin{aligned}
 i(t) &= I_s (e^{\gamma y(t)} - 1) \\
 &= a_1 y(t) + a_2 y(t)^2 + a_3 y(t)^3 + \dots \\
 &\approx a_2 \mu_Y(t)^2 + \sqrt{2} a_1 \mu_Y(t) \cos(2\pi f t + \phi_Y(t)) + a_2 \mu_Y^2(t) \cos(4\pi f t + 2\phi_Y(t))
 \end{aligned}$$

where  $a_n = \frac{I_s \gamma^n}{n!}$  is the Taylor coefficient.



## Wireless Power Transfer: Receiver Structure (2)

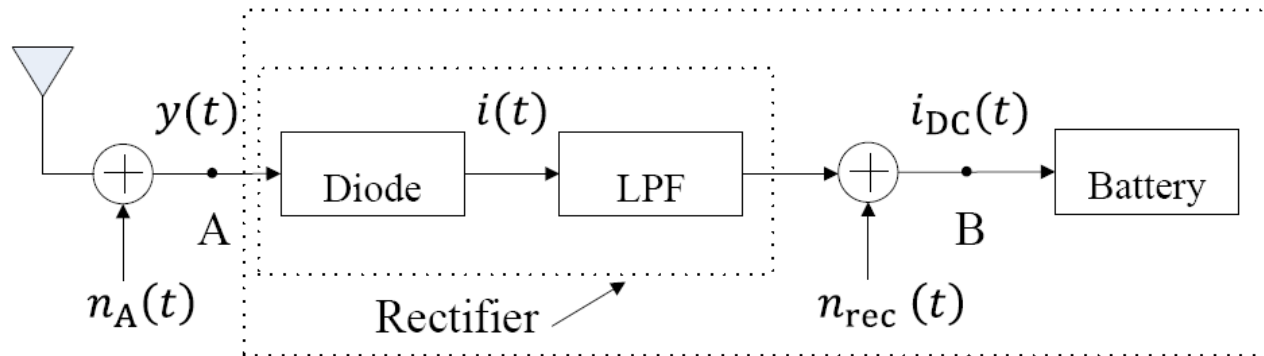

- The LPF removes all the harmonic components, i.e.  $f, 2f, \dots$ :

$$i_{DC}(t) = a_2 \mu_Y^2(t) + n_{rec}(t)$$

- Substituting  $\mu_Y(t)$ ,  $i_{DC}(t)$  is

$$\left( \sqrt{hP} A(t) \cos(\phi(t) + \theta) + n_I(t) \right)^2 + \left( \sqrt{hP} A(t) \sin(\phi(t) + \theta) + n_Q(t) \right)^2 + n_{rec}(t)$$

- Neglecting the noise power, the harvested power by the battery is

$$Q = \mathbb{E} [i_{DC}(t)] = \zeta \mathbb{E} [\|y(t)\|^2] = \zeta hP$$

## Scaling Up WPT: Energy Beamforming in MIMO Channel

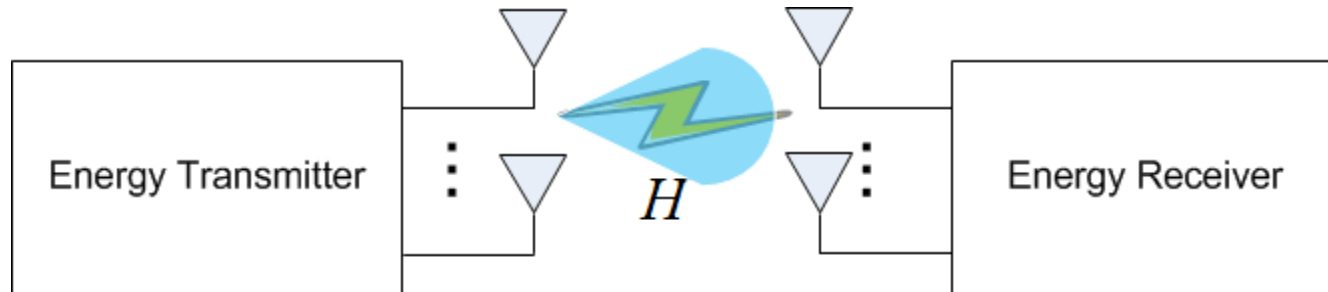

$$P_r = P_t \times G_a \times D^{-\alpha} \times \zeta$$

Antenna gain

Path loss

Energy conversion  
efficiency: 30% - 70%

- ❑  $G_a \approx (\# \text{ of Tx antennas}) \times (\# \text{ of Rx antennas})$ 
  - ❑ e.g.: 2×1 (3dB gain), 4×1 (6dB gain)...
- ❑ Diversity gain in fading channel (additional)
- ❑ Q: What's the optimal transmitting strategy given a limited power budget?
- ❑ A: Energy Beamforming (EB) [2]

## EB for Point-to-Point MIMO Channel

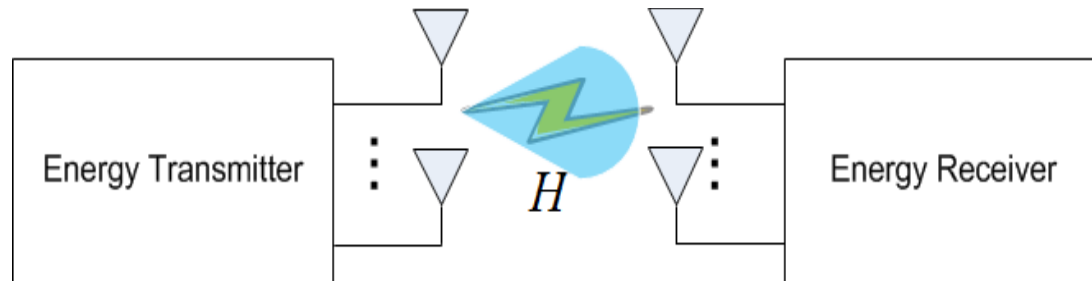

$$\underset{\mathbf{S}}{\text{maximize}} \quad \text{tr}(\mathbf{G}\mathbf{S})$$

$$\text{subject to} \quad \text{tr}(\mathbf{S}) \leq P, \quad \mathbf{S} \succeq \mathbf{0}$$

$$\text{where } \mathbf{G} = \mathbf{H}^H \mathbf{H}$$

- The harvested energy is

$$\zeta \|\mathbf{y}\|^2 = \zeta \|\mathbf{H}\mathbf{s}\|^2 = \zeta \text{tr}(\mathbf{G}\mathbf{S})$$

- **Energy beamforming (EB):**

- Tx steers beam(s) towards the Rx(s) to maximize the energy transfer efficiency
- EB is achieved by adjusting the transmit covariance matrix  $\mathbf{S}$
- The rank of  $\mathbf{S}$  indicates the number of beams generated

- The optimal EB is the **principal eigenvector beamforming** [2]

$$\mathbf{S}^* = P \mathbf{v}_E \mathbf{v}_E^H \quad \mathbf{v}_E \text{ is the principal eigenvector of } \mathbf{G}$$

- Implementation via distributed antennas: collaborative energy beamforming [5]

## MIMO Wireless Power Multicasting

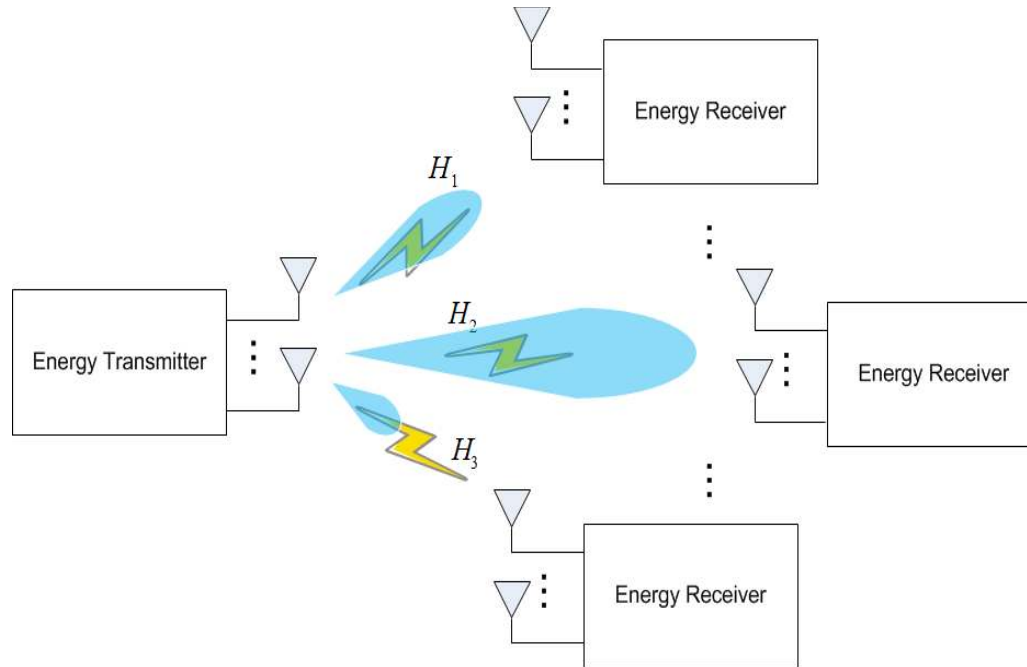

- ❑ Utilize the broadcast nature of microwave propagation for energy multicast
- ❑ **Energy near-far problem**: fairness is a key issue in the multicast EB design
  - May need to generate multiple beams to balance the energy harvesting performance
- ❑ In any case, the design of EB requires the accurate knowledge of **channel state information at the transmitter (CSIT)**

## Energy Beamforming w/o Full CSIT

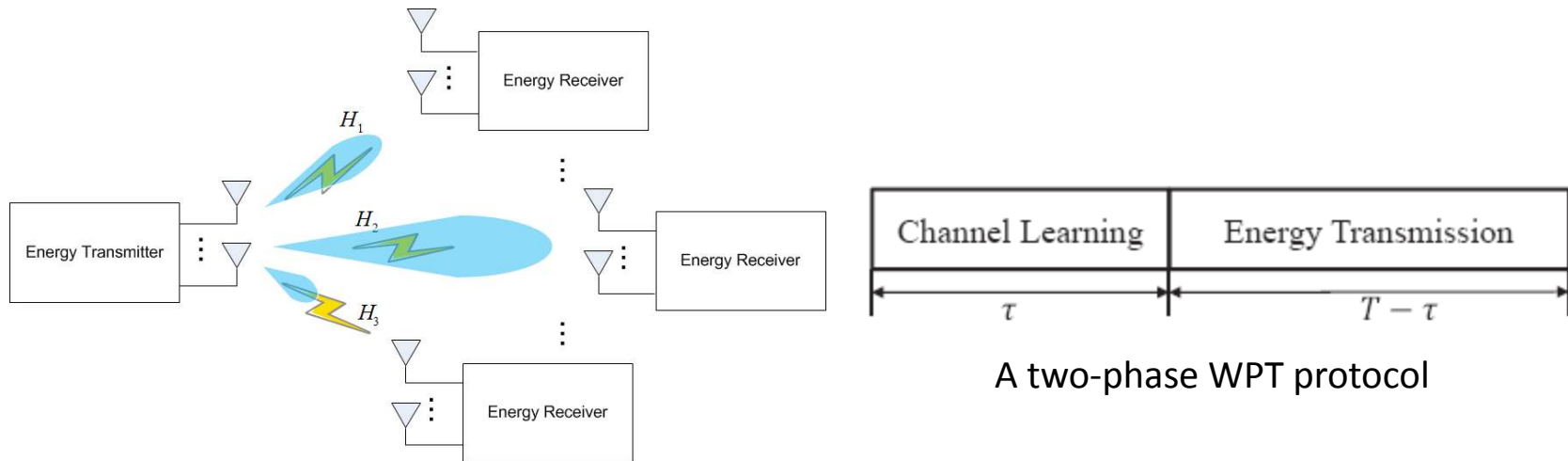

A two-phase WPT protocol

- ❑ Full CSIT is often **not available** due to
  - Hardware constraints at the energy receivers (rectifiers w/o baseband processing)
  - High channel estimation energy cost that may offset the gain from energy beamforming
- ❑ Candidate solutions:
  - Isotropic transmission (no CSIT needed, low efficiency)
  - EB based on **reverse-link training** (exploiting channel reciprocity) [6]
  - EB based on statistical CSIT (mean, covariance etc.)
  - EB based on **limited feedback** from the energy receivers [7]

## Energy Beamforming Based on One-bit Feedback [7]

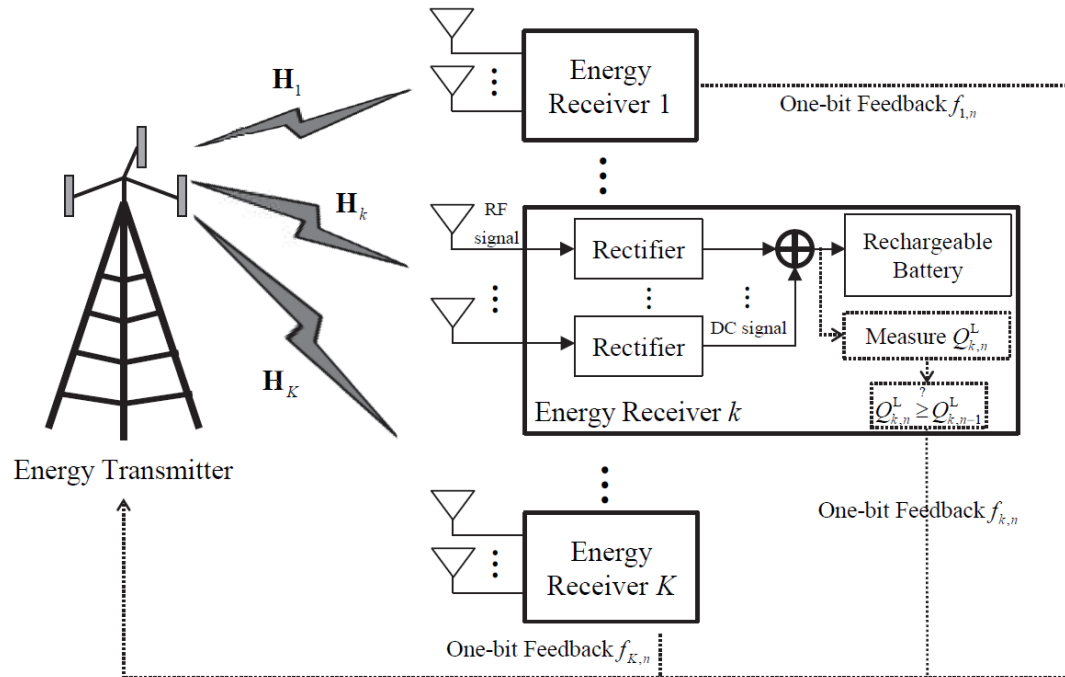

- ❑ Each receiver feeds back **one bit** information indicating its change of harvested energy compared to the previous time slot
- ❑ The transmitter adjusts its beamforming strategy based on the feedback bits

## Wireless Powered Communication: A General Model [2]

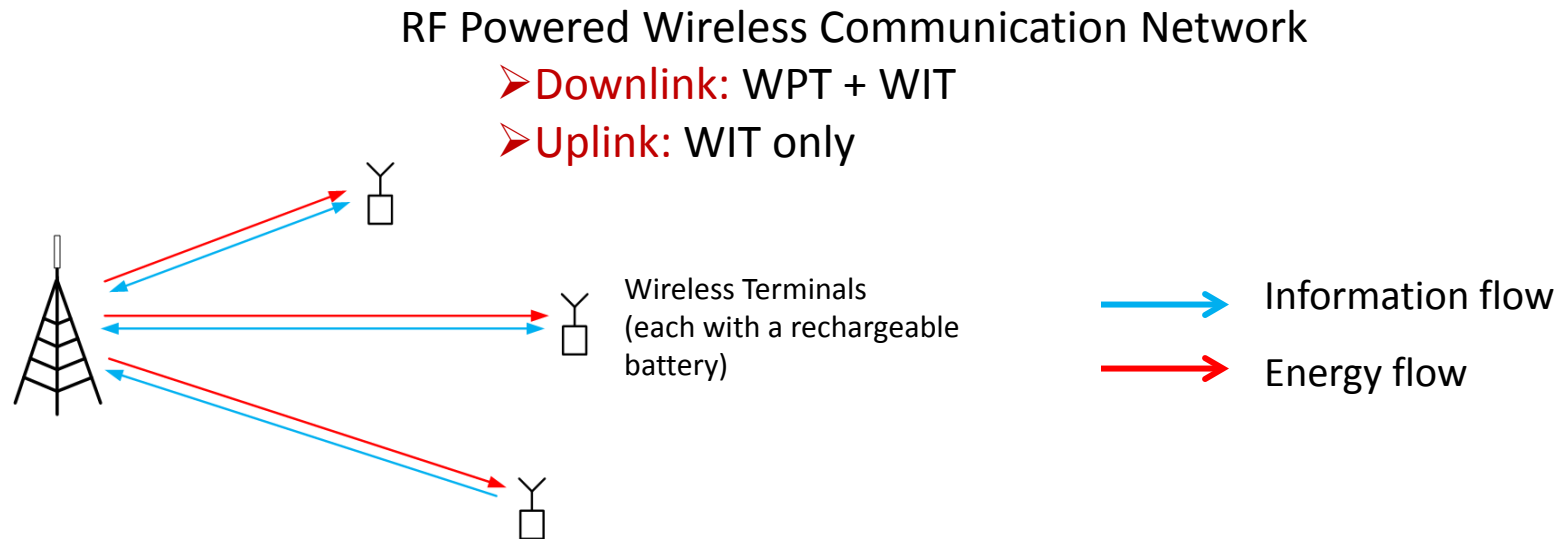

- ❑ **“Asymmetric”** information/energy flow
  - Need **joint** energy and communication scheduling and resource allocation
- ❑ Wireless information and power transfer (DL)
  - **Orthogonal** vs. **simultaneous** information and energy transmissions
  - Various rate-energy tradeoffs in SWIPT
- ❑ Information transfer using wireless harvested energy (UL)
  - Performance **tradeoff** between DL (energy) vs. UL (information)

## Joint Energy & Information Scheduling in WPCN

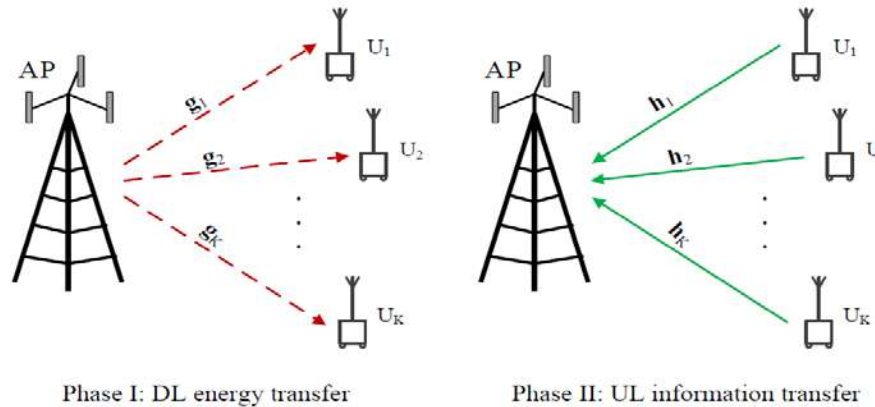

### □ Harvest-then-transmit protocol [3]

- Phase I: mobile terminals harvest energy from AP
- Phase II: transmit information under the harvested energy budget
- Similar design applies in frequency division based Energy and Info scheduling

### □ TDMA-based multiple access

- EB in the DL
- User air time allocation in the UL

### □ SDMA-based multiple access

- EB in the DL
- Spatial multiplexing in the UL
  - ✓ Joint DL beamforming & UL power control

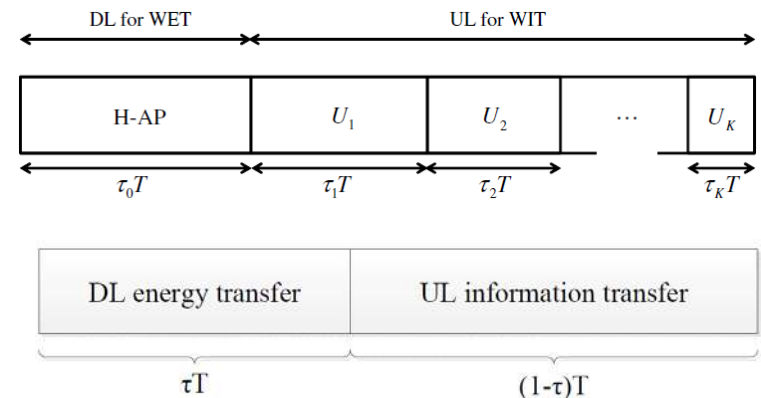



## “Doubly” Near-far Problem

### □ Doubly Near-Far Problem

- Due to distance-dependent signal attenuation in both DL and UL
- “Near” user harvests more energy in DL but transmits less power in UL
- “Far” user harvests less energy in DL but transmits more power in UL
- **Unbalanced** energy consumptions in the network: need more careful resource allocation

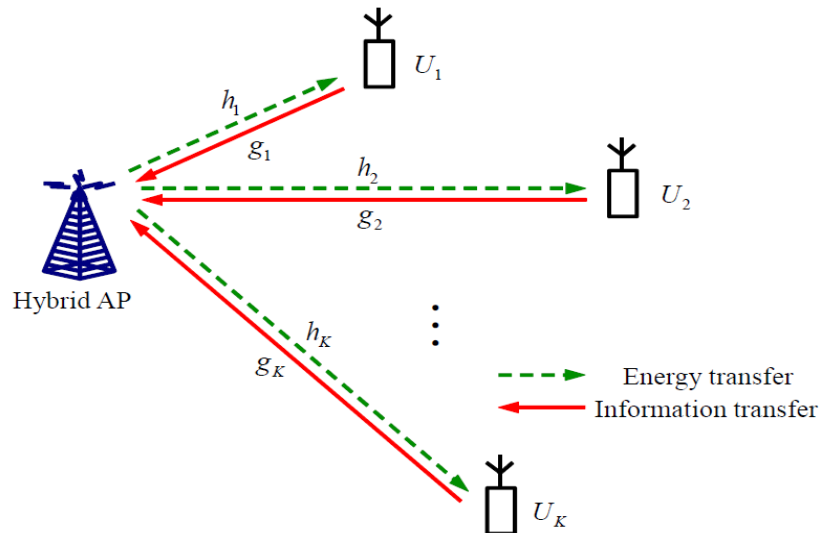

### □ Possible Solutions:

- Adaptive UL time allocation (TDMA) [3]
- Joint DL EB and UL power control (SDMA) [8]
- User cooperation (near user helps relay far user's message) [9]

# Wireless Powered Network Capacity

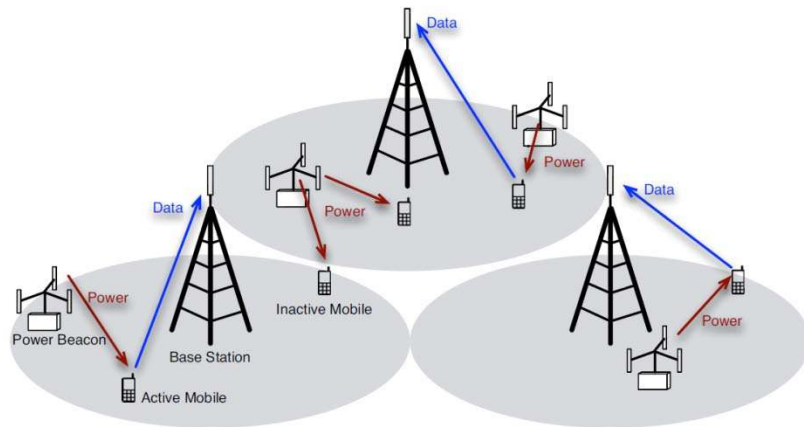

- ❑ **Hybrid cellular network:** cellular network + power beacons (PBs) to power mobile devices [10]:
- ❑ Design parameters:
  - $p, q$ : the transmit power of BSs and PBs
  - $\lambda_b, \lambda_p$ : densities of PPP of BSs and PBs
- ❑ Objective : optimize  $(p, q, \lambda_b, \lambda_p)$  to maximize the network throughput and yet guarantee the outage performance of information and power transfer

## ❑ Cognitive radio network [11]:

- ST **can** harvest energy from any nearby PT if it is in the PT's **harvesting zone**
- ST **cannot** transmit if it is in the **guard zone** of any PT

- ❑ Objective: maximize the secondary network throughput under opportunistic energy harvesting

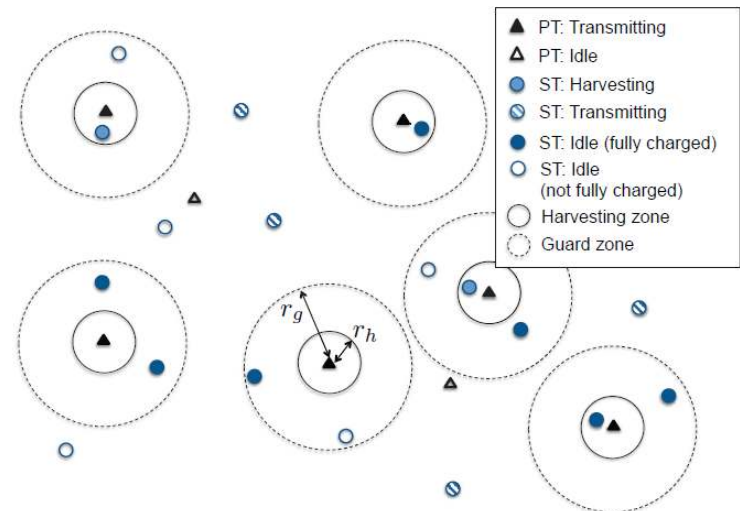

# Simultaneous Wireless Information and Power Transfer

## Wireless Power Transfer vs. Wireless Information Transfer

### Wireless Power Transfer

✓ Energy (in Joule) is **linearly** proportional to both **time** and **power**

### Wireless Information Transfer

✓ Information quantity (in bits) increases **linearly** with **time**

✓ but **logarithmically** with **power**

## Example: power allocation in frequency selective channel [12]

➤ Tesla's approach: allocate all power to a single sinusoid tone (zero bandwidth)

➤ Shannon's approach: water-filling power allocation

➤ Similar tradeoff exists in **spatial domain (MIMO system)** power allocation [2]

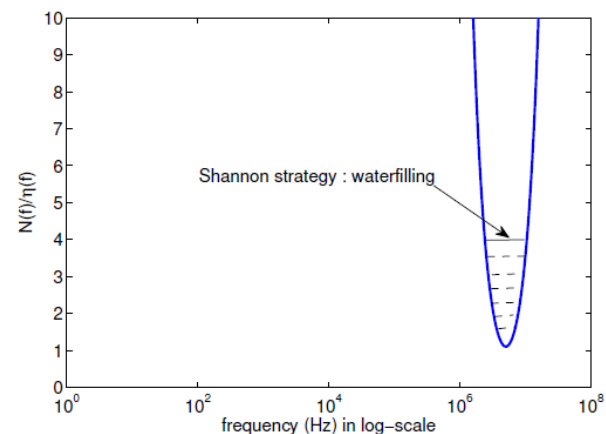
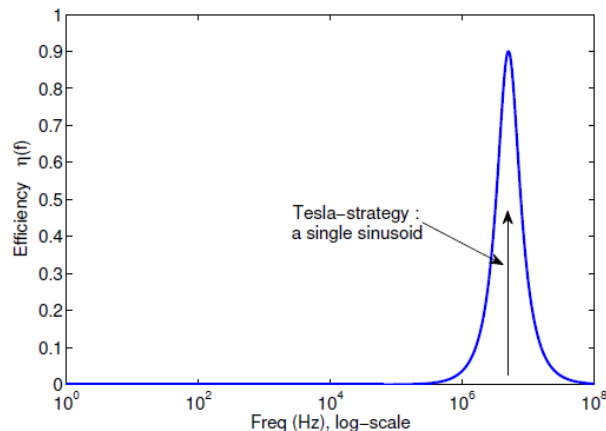

## MIMO SWIPT with Two Separate EH and ID Terminals [2]

- **Rate-energy region:** all the achievable rate and energy pairs under a given transmit power constraint  $P$

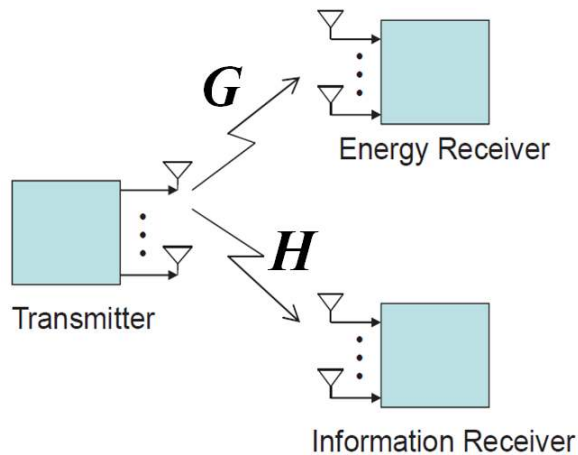

$$\begin{aligned} \max_{\mathbf{S}} \quad & \log |\mathbf{I} + \mathbf{H}\mathbf{S}\mathbf{H}^H| \\ \text{s.t.} \quad & \text{tr}(\mathbf{G}\mathbf{S}\mathbf{G}^H) \geq \bar{Q} \\ & \text{tr}(\mathbf{S}) \leq P \\ & \mathbf{S} \succeq 0. \end{aligned}$$

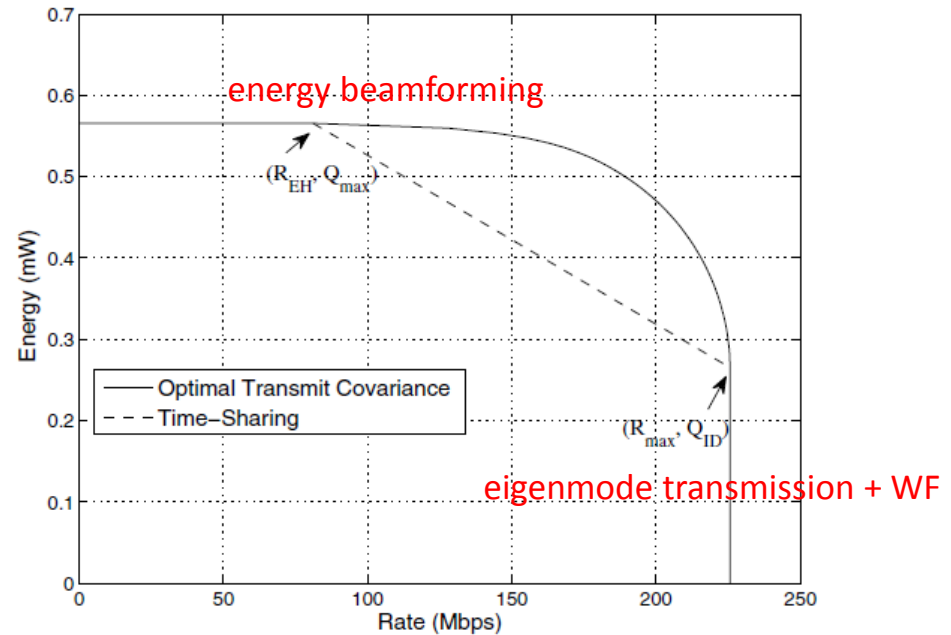

Each terminal has 4 antennas,  $P = 1\text{W}$ , EH receiver 1m, ID receiver 10m distance

## Separate EH and ID Receivers: a Network Perspective

- The **receiver “sensitivity” issue** (different receiver operating power)
  - Wireless information receiver:  $> -60\text{dBm}$
  - Wireless energy receiver:  $> -10\text{dBm}$
  
- **Near-Far** based transmission scheduling
  - Harvest energy when user is close to H-AP
  - Receive information when user is far from H-AP

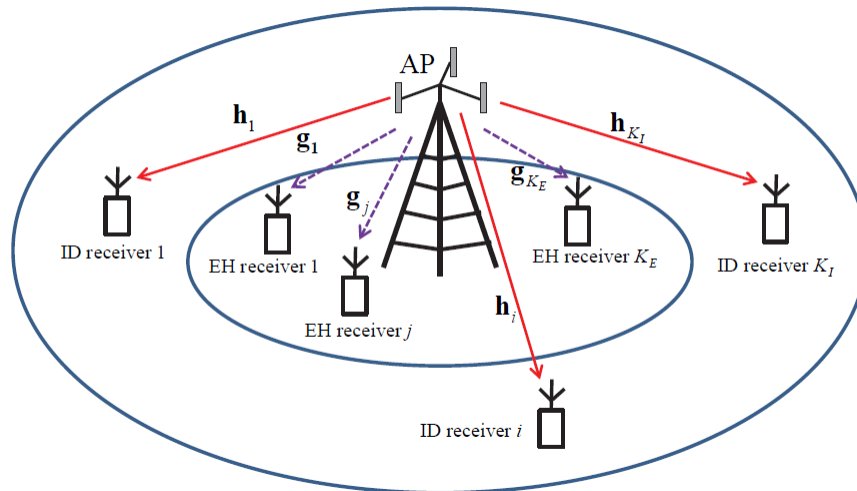

E.g., maximizing weighted sum energy harvested for EH receivers under SINR constraints for ID receivers [13]

## Rate-Energy Tradeoff for an Ideal Co-located EH/ID Receiver

- An “**ideal**” receiver can harvest the energy and decode information simultaneously
  - However, practical receiver **cannot** achieve both from the same signal
- Rate-energy tradeoff in a discrete memoryless channel [14]

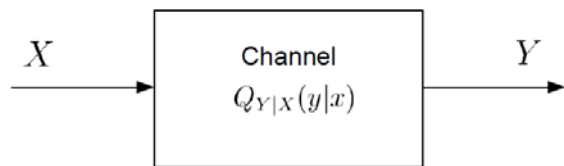

$$C_n(B) = \max_{X_1^n: E[b(Y_1^n)] \geq nB} I(X_1^n; Y_1^n)$$

$$C(B) = \sup_n \frac{1}{n} C_n(B) \quad \leftarrow \text{Capacity-energy function}$$

- Rate-energy performance upper bound
  - e.g., SISO AWGN channel:

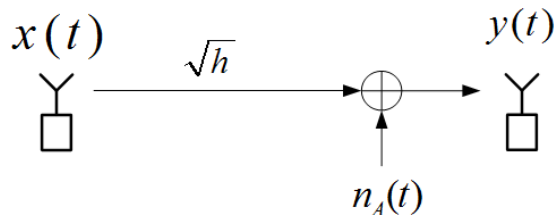

$$C_{R-E}^{UB}(P) \triangleq \left\{ (R, Q) : R \leq \log_2 \left( 1 + \frac{hP}{\sigma_A^2} \right), Q \leq hP \right\}$$

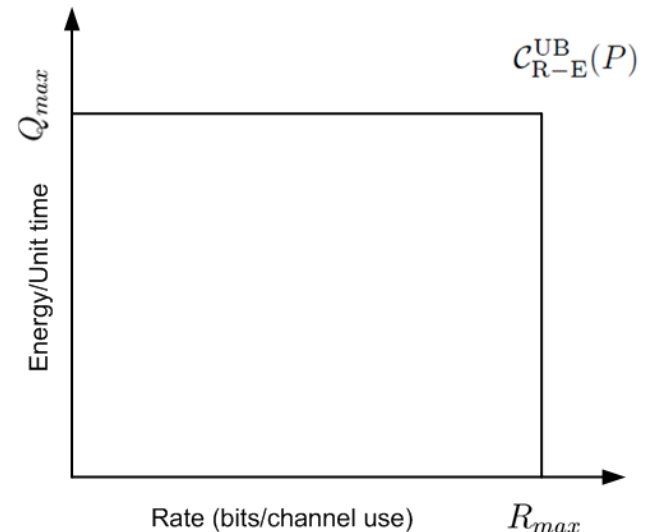

## Separate Information and Energy Receivers: General Structure [4]

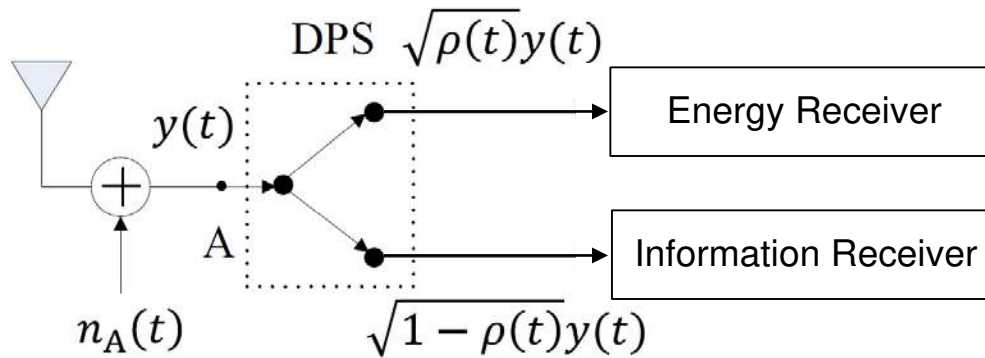

- ❑ In practice, energy cannot be harvested after information decoding
- ❑ Received signal splits at **RF band** (point A): **Power Splitting (PS)**
- ❑ Power splitting ratio can be set differently over time
- ❑ Special Case: **Time Switching (TS)** with binary power splitting ratio

## Integrated Information and Energy Receivers Structure [4]

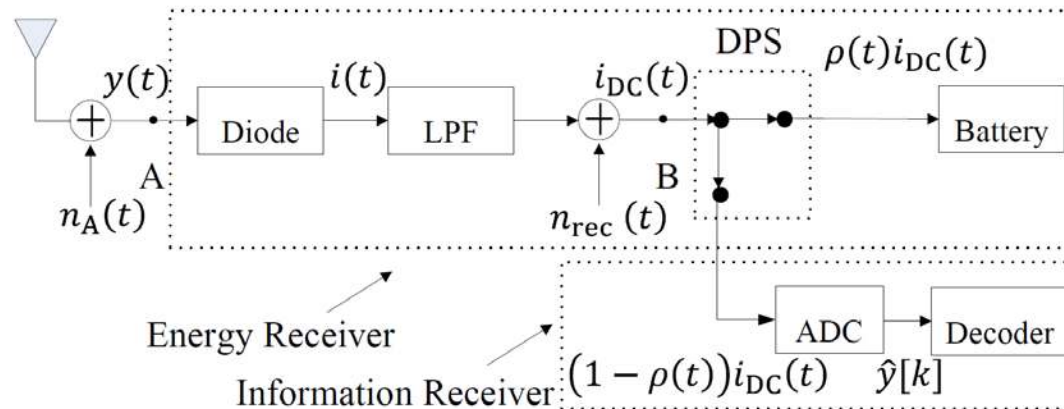

- ❑ Received signal splits at **baseband** (point B)
- ❑ Information is carried in the DC signal  $i_{DC}(t)$ 
  - Conventional phase-amplitude modulation (e.g., QAM) not applicable since requiring coherent demodulation
  - Solution: **energy modulation & detection**
- ❑ Advantages of integration:
  - RF to baseband conversion is by passive diode -> less circuit power
  - **Integrated** EH and ID circuits -> smaller form factor



# Rate-Energy Region of SWIPT in Point-to-Point AWGN [1]

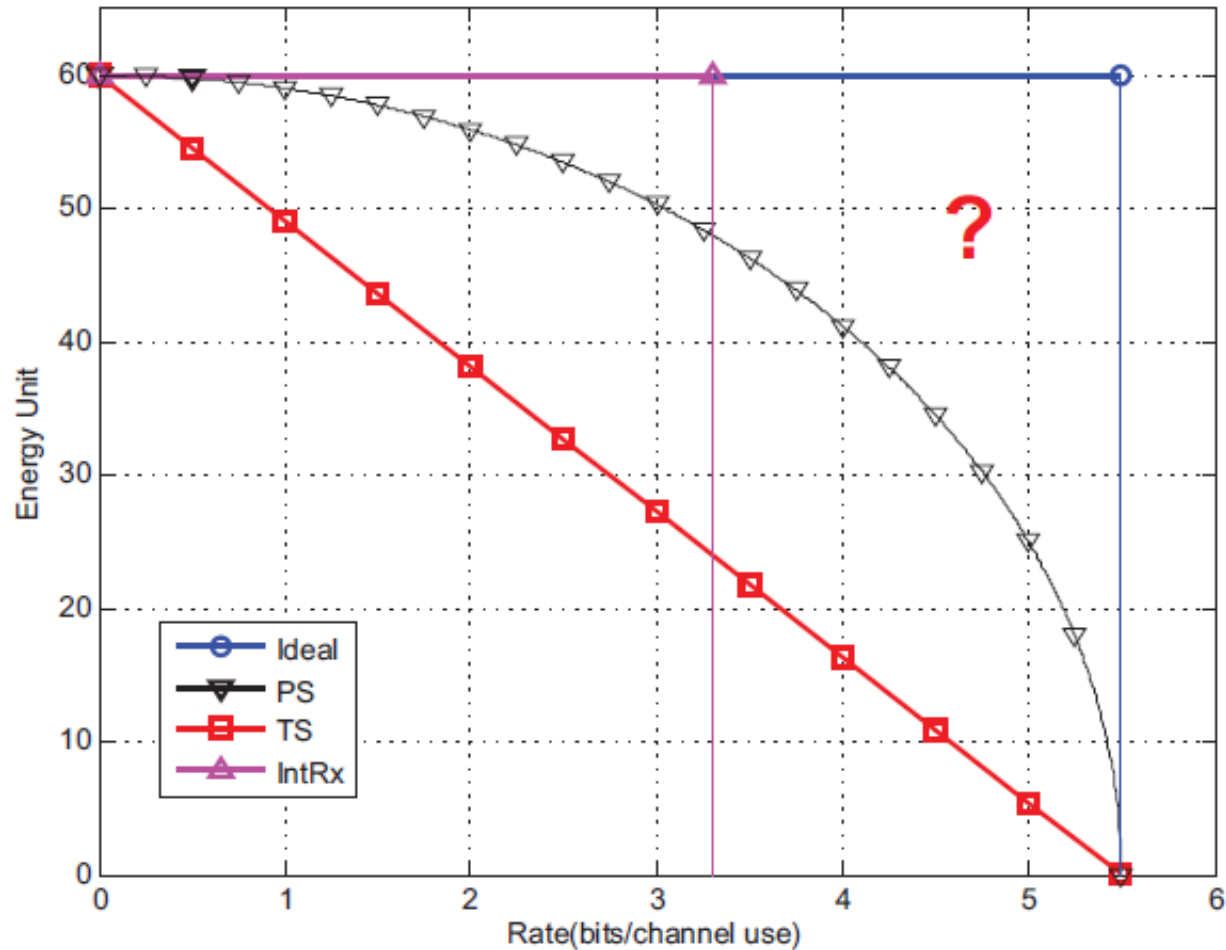

## Practical Example: SepRx vs. IntRx for A Self-sustainable Receiver [4]

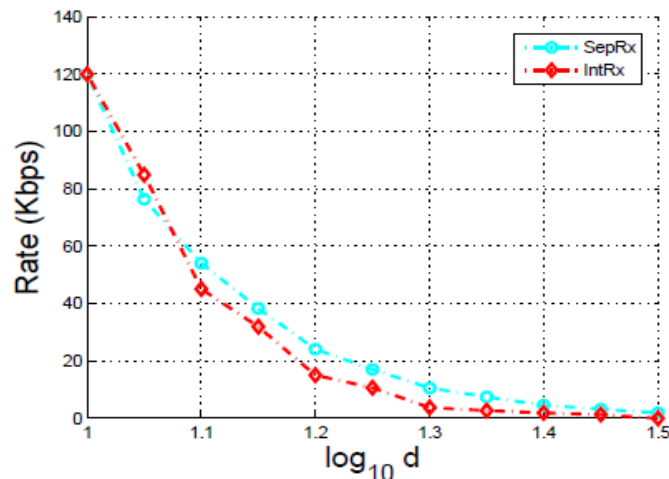
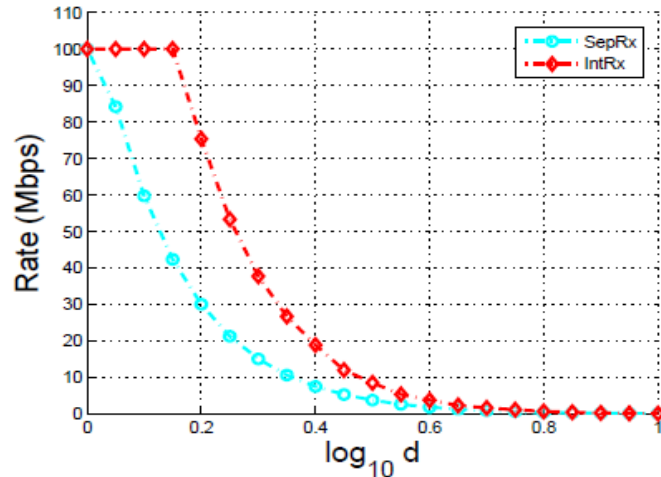

- $P = 1\text{W}$  (30dBm)
- $f_c = 900\text{MHz}$ ,  $B_w = 10\text{MHz}$
- signal power attenuation:  
( $-30 - 30 \log_{10} d$ )dB
- $\sigma_A^2 = -104\text{dBm}$ ,  $\sigma_{\text{cov}}^2 = -70\text{dBm}$ ,  
 $\sigma_{\text{rec}} = -50\text{dBm}$
- $\zeta = 0.6$ , net energy equals to zero
- $P_S = 0.5\text{mW}$ ,  $P_I = 0.2\text{mW}$
- symbol error rate target:  $10^{-5}$
- quadrature amplitude modulation (QAM) for separated receiver
- pulse energy modulation (PEM) for integrated receiver

## Point-to-Multipoint SWIPT: Harmful vs. Helpful Interference

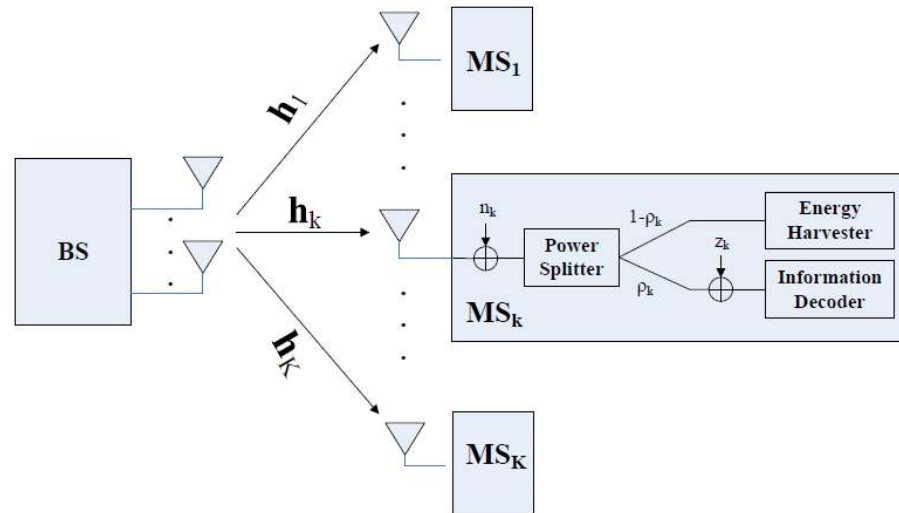

One energy & Info Tx, many co-located receivers [15]

- ❑ Co-channel interference exists in downlink information transmission
- ❑ Interference is **harmful** to wireless information transmission (treated as noise if not decodable at receiver)
- ❑ But **helpful** to wireless energy transmission (additional source of energy harvesting at receiver)
- ❑ Joint energy & Info beamforming for **interference management** in SWIPT

## Dynamic Time Switching over Fading Channels

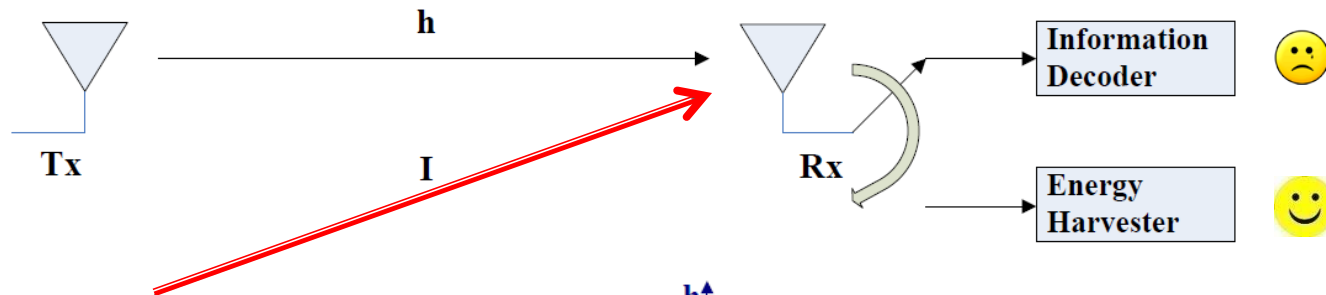

- ❑ Fading channel + **Interference**
- ❑ Opportunistic EH and ID [16]:
  - decode information when **SNR** is sufficiently **high** and received **signal** (information + interference) is **weak**
  - Harvest energy otherwise.
- ❑ Optimal EH and ID operating region characterization.

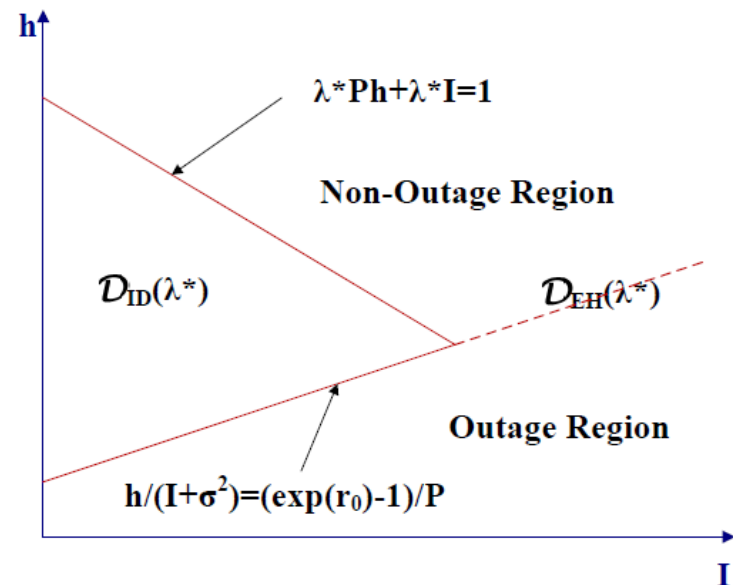

The region within the triangle is the **optimal operating region** for information decoding given a pair of channel power and interference power ( $h, I$ )

## DPS over Fading Channels

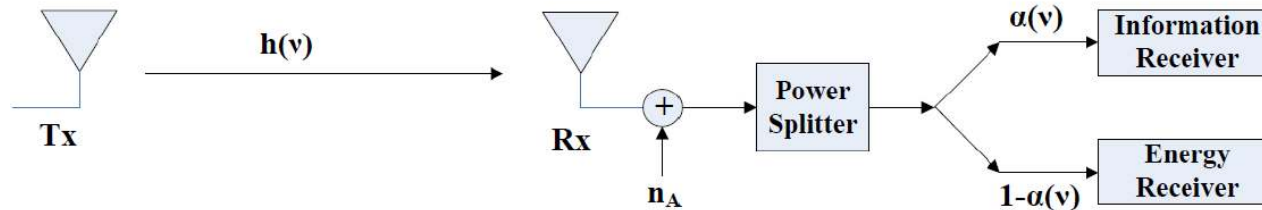

- ❑ A more general scheme is **DPS** between EH and ID receivers based on the fading state [17]:
  - Time switching is the special case with on/off (binary) power splitting ratio  $\alpha$ .
- ❑ Optimal power splitting rules:
  - When fading state is “poor”, all received power is allocated to information receiver.
  - When fading state is “good”, received power split between the information and energy receivers (**constant power** to the information receiver).

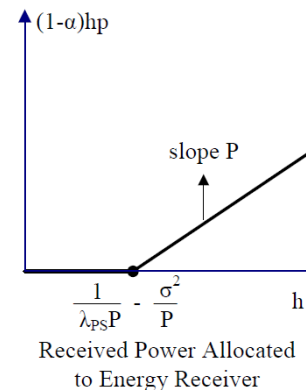
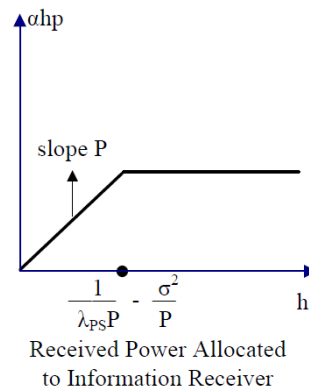

## Dynamic Power Splitting vs. Dynamic Antenna Switching [17]

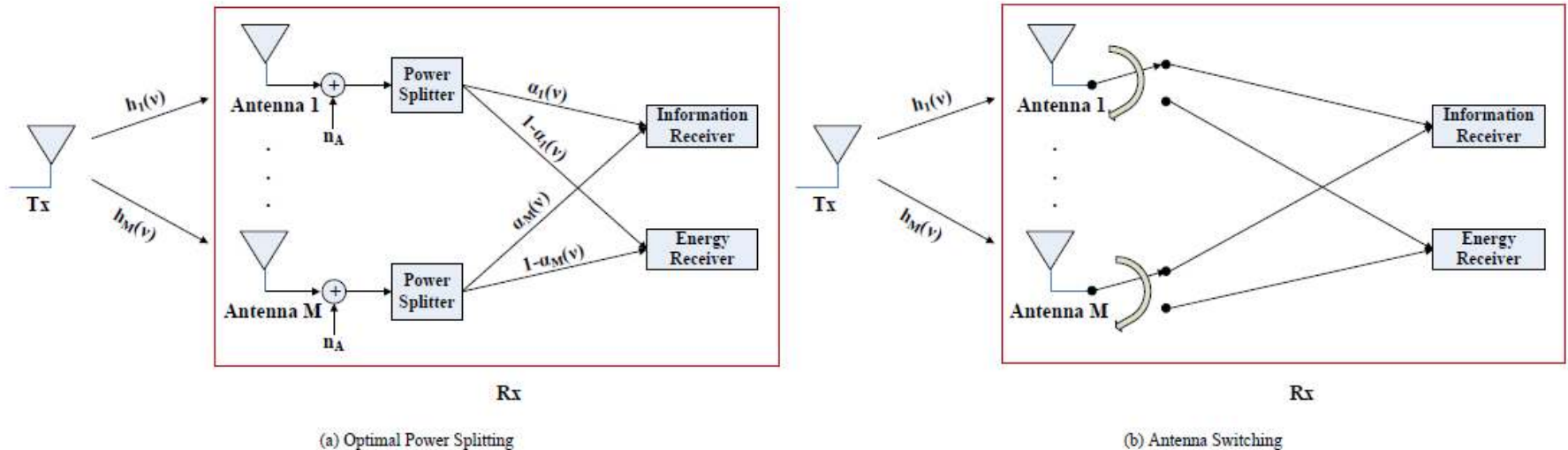

- Dynamic antenna switching between EH and ID is a special case of DPS with on/off (binary) power splitting ratio  $\alpha$  per receive antenna.
- DPS achieves better R-E region than antenna switching, but antenna switching has much lower **hardware complexity**.

## Multi-Transmitter Collaborative SWIPT

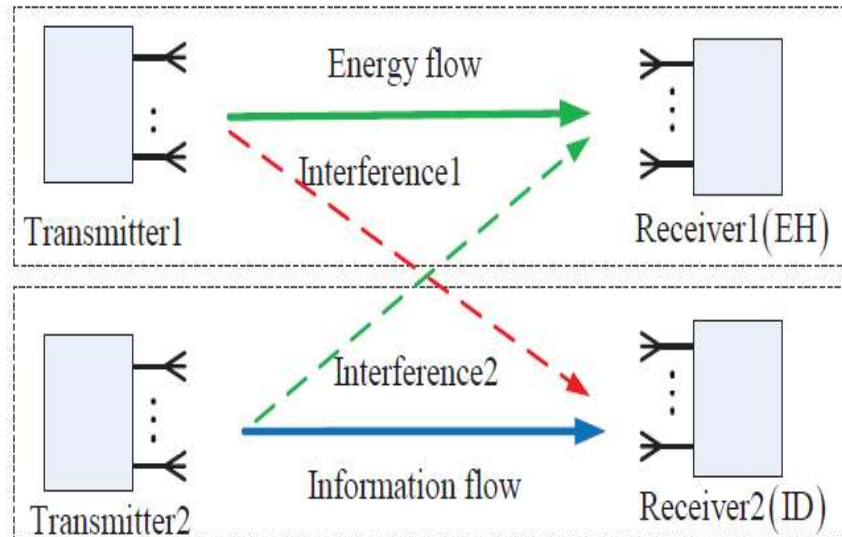

An  $2 \times 2$  interference channel for SWIPT with TS receivers

- ❑ Receivers can use **time switching (TS)** from four modes [18]: (EH,EH), (EH,ID), (ID,EH),(ID,ID)
- ❑ Receivers can also use **power splitting** to balance the rate-energy performance [19,20]
- ❑ **Interference channel** rate-energy tradeoff characterization [5]

## SWIPT with Energy/Information Relaying

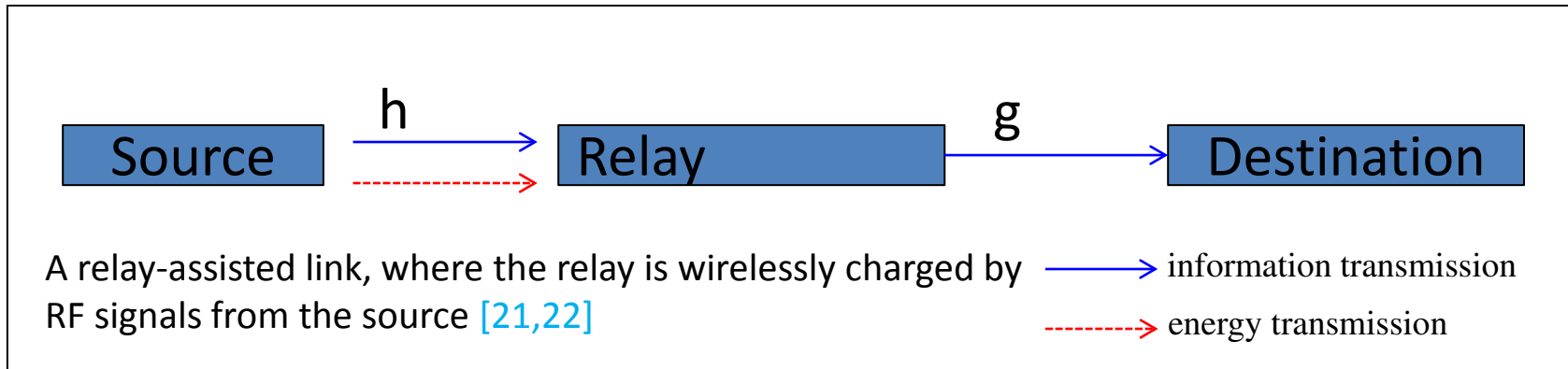

### TS Relay

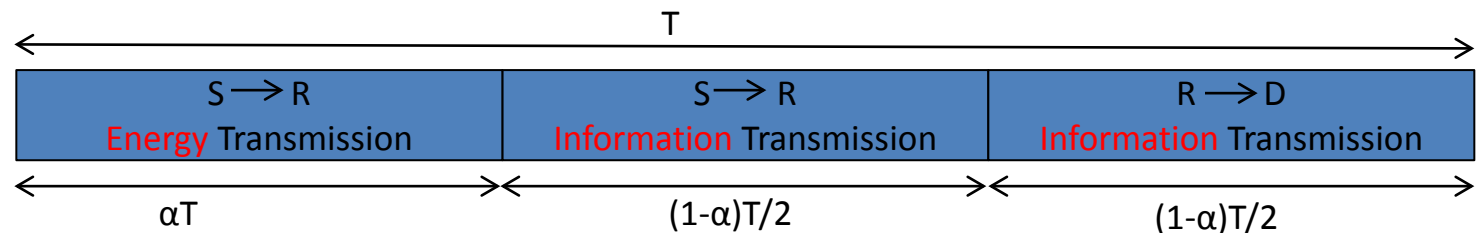

### PS Relay

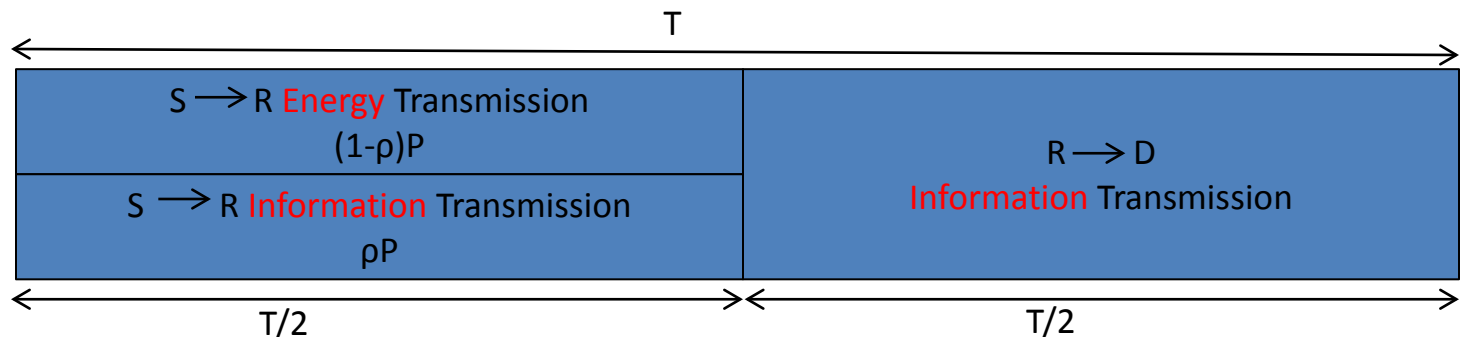



## SWIPT in Multi-User OFDM

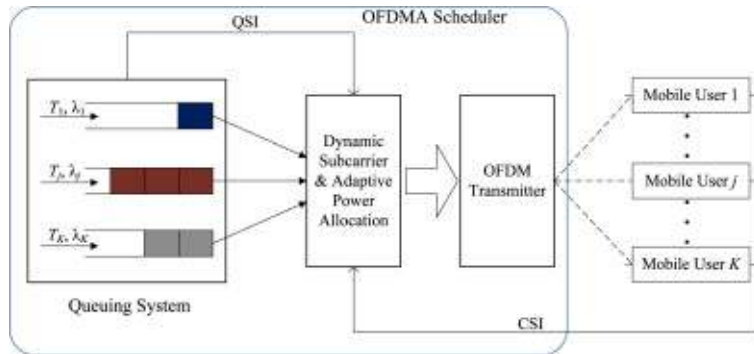

Multi-user OFDM

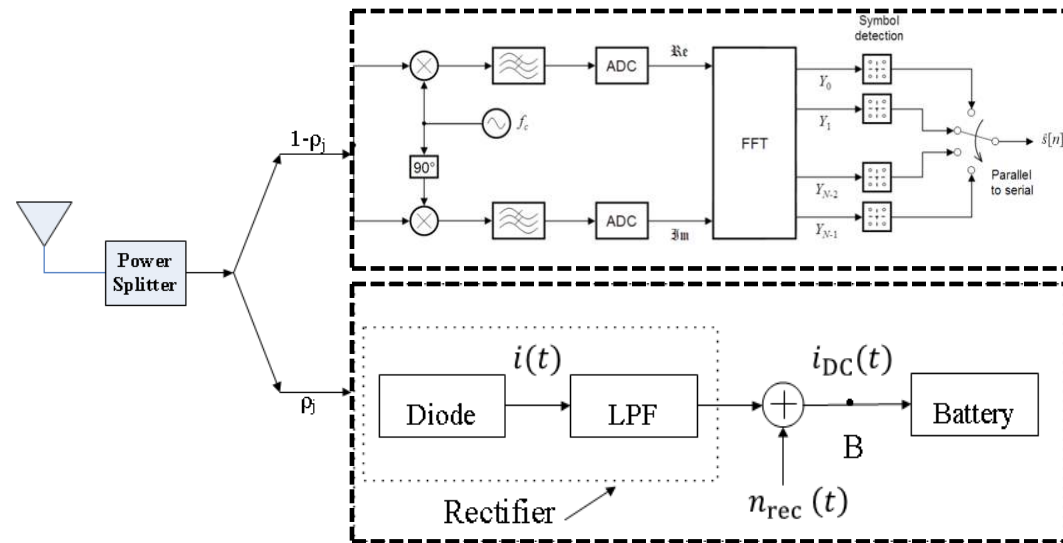

OFDM Receiver with Power Splitting (PS)

- ❑ **OFDMA with PS receivers** : PS is performed **before digital** OFDM demodulation. Thus, all subcarriers should have the same PS ratio at each receiver.
- ❑ **TDMA with TS receivers** : Each user performs ID when information is scheduled for that user, and performs EH in all other time slots
- ❑ R-E tradeoff characterizations for multi-carrier SWIPT [23, 24, 25]

## Summary of Wireless Powered Communications

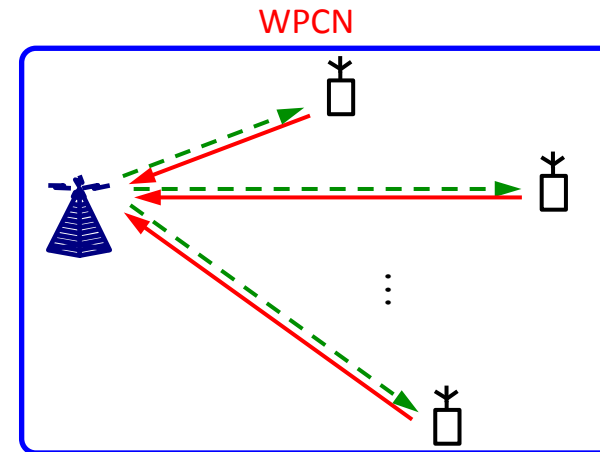
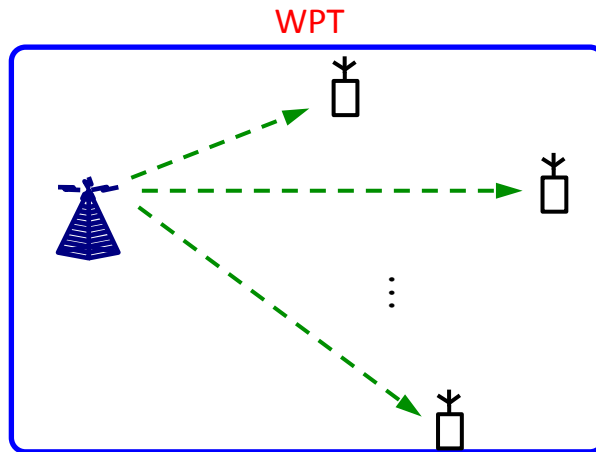

SWIPT: Separate EH/ID Receivers

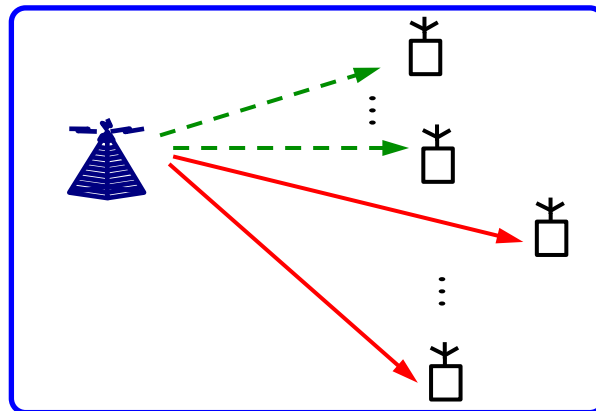

SWIPT: Co-located EH/ID Receivers

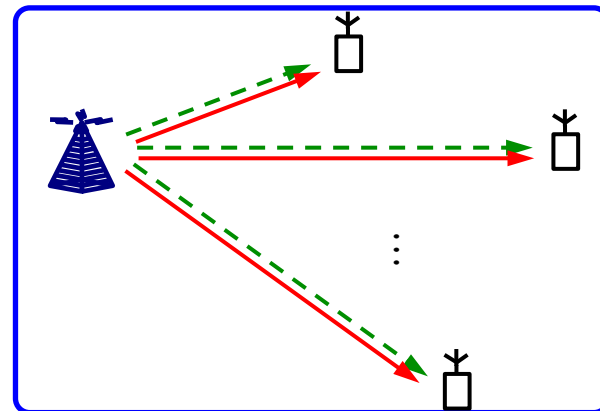

---> Energy transfer    —> Information transfer

# Agenda

- ❑ Part I: Wireless Power: History and State-of-the-Art
- ❑ Part II: Overview of Wireless Powered Communications
- ❑ Conclusion and Future Work Direction

# Conclusions

## □ RF Powered Wireless Communications

- Fundamental limits: still open
- Many new design challenges in PHY, MAC, and Network layers

## □ Hardware Development

- Wireless power transfer (energy beamforming, high-efficiency rectifier, waveform design,...)
- Practical receivers for SWIPT (e.g., time switching, power splitting, antenna switching, integrated receiver,...)

## □ Applications

- Wireless sensor/IoT networks
- Cellular networks (small cell + millimeter-wave + massive MIMO?)
- ...

## Future Work Directions

- ❑ Information-theoretic limits of WPCN/SWIPT
  - See e.g. [26, 27, 4]
- ❑ Massive MIMO based WPT/WPCN/SWIPT
  - See e.g. [28]
- ❑ Imperfect CSIT and practical feedback in WPT/WPCN/SWIPT
  - See e.g. [29, 30, 6, 7]
- ❑ Full-duplex WPCN/SWIPT
  - See e.g. [31]
- ❑ Secrecy communication issues in WPCN/SWIPT
  - See e.g. [32, 33, 34]
- ❑ Many others (WPT/WIT coexisting, cross-layer design, hardware development, safety issue, ....)
  - See e.g. [1, 35]

## References

- [1] S. Bi, C. K. Ho, and **R. Zhang**, “Wireless powered communication: opportunities and challenges,” submitted for publication. (available on-line at arXiv:1408.2335)
- [2] **R. Zhang** and C. K. Ho, “MIMO broadcasting for simultaneous wireless information and power transfer,” *IEEE Transactions on Wireless Communications*, vol. 12, no. 5, pp. 1989-2001, May 2013.
- [3] H. Ju and **R. Zhang**, “Throughput maximization in wireless powered communication networks,” *IEEE Transactions on Wireless Communications*, vol. 13, no. 1, pp. 418-428, Jan. 2014.
- [4] X. Zhou, **R. Zhang**, and C. K. Ho, “Wireless information and power transfer: architecture design and rate-energy tradeoff,” *IEEE Transactions on Communications*, vol. 61, no. 11, pp. 4757-4767, Nov. 2013.
- [5] S. Lee, L. Liu, and **R. Zhang**, “Collaborative wireless energy and information transfer in interference channel,” to appear in *IEEE Transactions on Wireless Communications*. (available on-line at arXiv:1402.6441)
- [6] Y. Zeng and **R. Zhang**, “Optimal training for wireless energy transfer,” submitted to *IEEE Transactions on Communications*. (available on-line at arXiv:1403.7870)
- [7] J. Xu and **R. Zhang**, “Energy beamforming with one-bit feedback,” to appear in *IEEE Transactions on Signal Processing*. (Available on-line at arXiv:1312.1444)
- [8] L. Liu, **R. Zhang**, and K. C. Chua, “Multi-antenna wireless powered communication with energy beamforming,” submitted to *IEEE Transactions on Communications*. (Available on-line at arXiv:1312.1450)

- [9] H. Ju and **R. Zhang**, “User cooperation in wireless powered communication networks,” to appear in IEEE Global Communications Conference (Globecom), 2014. (available on-line at arXiv:1403.7123)
- [10] K. Huang and V. K. N. Lau, “Enabling wireless power transfer in cellular networks: architecture, modeling and deployment,” *IEEE Transactions on Wireless Communications*, vol. 13, no. 2, pp. 902-912, Feb. 2014.
- [11] S. Lee, **R. Zhang**, and K. B. Huang, “Opportunistic wireless energy harvesting in cognitive radio networks,” *IEEE Transactions on Wireless Communications*, vol. 12, no. 9, pp. 4788-4799, Sept. 2013.
- [12] P. Grover and A. Sahai, “Shannon meets Tesla: wireless information and power transfer”, in *Proc. IEEE ISIT*, pp. 2363-2367, 2010.
- [13] J. Xu, L. Liu, and **R. Zhang**, “Multiuser MISO beamforming for simultaneous wireless information and power transfer,” *IEEE Transactions on Signal Processing*, vol. 62, no. 18, pp. 4798-4810, September, 2014.
- [14] L. R. Varshney, “Transporting information and energy simultaneously,” in *Proc. IEEE ISIT*, pp. 1612-1616, 2008.
- [15] Q. Shi, L. Liu, W. Xu, and **R. Zhang**, “Joint transmit beamforming and receive power splitting for MISO SWIPT systems,” *IEEE Transactions on Wireless Communications*, vol. 13, no. 6, pp. 3269-3280, June, 2014.
- [16] L. Liu, **R. Zhang**, and K. C. Chua, “Wireless information transfer with opportunistic energy harvesting,” *IEEE Transactions on Wireless Communications*, vol. 12, no. 1, pp. 288-300, Jan. 2013.
- [17] L. Liu, **R. Zhang**, and K. C. Chua, “Wireless information and power transfer: a dynamic power splitting approach,” *IEEE Trans. Communications*, vol. 61, no. 9, pp. 3990-4001, Sept. 2013.

- [18] J. Park and B. Clerckx, "Joint wireless information and energy transfer in a two-user MIMO interference channel," *IEEE Trans. Wireless Communications*, vol. 12, no. 8, pp. 4210-4221, Aug. 2013.
- [19] C. Shen, W. C. Li, and T. H. Chang, "Simultaneous information and energy transfer: a two-user MISO interference channel case," in *Proc. IEEE Globecom*, 2012.
- [20] S. Timotheou, I. Krikidis, and B. Ottersten, "MISO interference channel with QoS and RF energy harvesting constraints," in *Proc. IEEE ICC*, 2013.
- [21] A. A. Nasir, X. Zhou, S. Durrani, and R. A. Kennedy, "Relaying protocols for wireless energy harvesting and information processing," *IEEE Trans. Wireless Communications*, vol. 12, no. 7, July 2013
- [22] I. Krikidis, S. Timotheou, and S. Sasaki, "RF energy transfer for cooperative networks: data relaying or energy harvesting," *IEEE Wireless Communication Letters*, vol. 16, no. 11, pp. 1772-1775, Nov. 2012.
- [23] X. Zhou, **R. Zhang**, and C. K. Ho, "Wireless information and power transfer in multiuser OFDM systems," *IEEE Trans. Wireless Communications*, vol. 13, no. 4, pp. 2282-2294, Apr. 2014.
- [24] K. Huang and E. Larsson, "Simultaneous information and power transfer for broadband wireless systems," *IEEE Trans. Signal Processing*, vol. 61, No. 23, pp. 5972-5986, Dec 2013.
- [25] D. W. K. Ng, E. S. Lo, and R. Schober, "Wireless information and power transfer: energy efficiency optimization in OFDMA systems," *IEEE Trans. Wireless Communications*, vol. 12, no. 12, pp. 6352-6370, Dec. 2013.
- [26] P. Popovski, A. M. Fouladgar, and O. Simeone, "Interactive joint transfer of energy and information," *IEEE Transactions on Communications*, vol. 61, no. 5, pp. 2086–2097, May 2013.
- [27] A. M. Fouladgar and O. Simeone, "On the transfer of information and energy in multi-user systems," *IEEE Wireless Communication Letters*, vol. 16, no. 11, pp. 1733-1736, Nov. 2012.



- [28] G. Yang, C. K. Ho, **R. Zhang**, and Y. L. Guang, “Throughput optimization for massive MIMO systems powered by wireless energy transfer,” submitted to *IEEE Journal on Selected Areas in Communications*.(available on-line at arXiv:1403.3991)
- [29] Z. Xiang, and M. Tao, “Robust beamforming for wireless information and power transmission,” *IEEE Wireless Communication Letters*, vol. 1, no. 4, pp. 372-375, Aug. 2012.
- [30] H. Ju and **R. Zhang**, “A novel model switching scheme utilizing random beamforming for opportunistic energy harvesting,” *IEEE Transactions on Wireless Communication*, vol. 13, no. 4, pp. 2150-2162, Apr. 2014.
- [31] H. Ju and **R. Zhang**, “Optimal resource allocation in full-duplex wireless powered communication network,” to appear in *IEEE Transactions on Communications*.(available on-line at arXiv:1403.2580)
- [32] L. Liu, **R. Zhang**, and K. C. Chua, “Secrecy wireless information and power transfer with MISO beamforming,” *IEEE Transactions on Signal Processing*, vol. 62, no. 7, pp. 1850-1863, Apr. 2014.
- [33] D. W. K. Ng, E. S. Lo, and R. Schober, “Robust beamforming for secure communication in systems with wireless information and power transfer,” *IEEE Trans. Wireless Communication*, vol. 13, pp. 4599–4615, Aug. 2014.
- [34] H. Xing, L. Liu, and **R. Zhang**, “Secrecy wireless information and power transfer in fading wiretap channel,” submitted to *IEEE Transactions on Vehicular Technology*.(available on-line at arXiv:1408.1987)
- [35] S. Bi, C. K. Ho, and **R. Zhang**, “Recent advances in joint wireless energy and information transfer,” to appear in *IEEE Information Theory Workshop*, 2014. (available on-line at arXiv:1407.0474)