



UvA-DARE (Digital Academic Repository)

Without it no music: Cognition, biology, and evolution of musicality

Honing, H.; ten Cate, C.; Peretz, I.; Trehub, S.E.

DOI

[10.1098/rstb.2014.0088](https://doi.org/10.1098/rstb.2014.0088)

Publication date

2015

Document Version

Final published version

Published in

Philosophical Transactions of the Royal Society B - Biological Sciences

[Link to publication](#)

Citation for published version (APA):

Honing, H., ten Cate, C., Peretz, I., & Trehub, S. E. (2015). Without it no music: Cognition, biology, and evolution of musicality. *Philosophical Transactions of the Royal Society B - Biological Sciences*, 370(1664), [20140088]. <https://doi.org/10.1098/rstb.2014.0088>

General rights

It is not permitted to download or to forward/distribute the text or part of it without the consent of the author(s) and/or copyright holder(s), other than for strictly personal, individual use, unless the work is under an open content license (like Creative Commons).

Disclaimer/Complaints regulations

If you believe that digital publication of certain material infringes any of your rights or (privacy) interests, please let the Library know, stating your reasons. In case of a legitimate complaint, the Library will make the material inaccessible and/or remove it from the website. Please Ask the Library: <https://uba.uva.nl/en/contact>, or a letter to: Library of the University of Amsterdam, Secretariat, Singel 425, 1012 WP Amsterdam, The Netherlands. You will be contacted as soon as possible.

CrossMark
click for updates

Introduction

Cite this article: Honing H, ten Cate C, Peretz I, Trehub SE. 2015 Without it no music: cognition, biology and evolution of musicality. *Phil. Trans. R. Soc. B* **370**: 20140088. <http://dx.doi.org/10.1098/rstb.2014.0088>

One contribution of 12 to a theme issue 'Biology, cognition and origins of musicality'.

Subject Areas:

behaviour, evolution, cognition, neuroscience, theoretical biology, genetics

Keywords:

musicality, music perception, music cognition, evolution of music, multicomponent view

Author for correspondence:

Henkjan Honing
e-mail: honing@uva.nl

Without it no music: cognition, biology and evolution of musicality

Henkjan Honing¹, Carel ten Cate², Isabelle Peretz³ and Sandra E. Trehub⁴

¹Amsterdam Brain and Cognition (ABC), Institute for Logic, Language and Computation (ILLC), University of Amsterdam, PO Box 94242, 1090 CE Amsterdam, The Netherlands

²Institute of Biology Leiden (IBL), Leiden Institute for Brain and Cognition (LIBC), Leiden University, PO Box 9505, 2300 RA Leiden, The Netherlands

³Center for Research on Brain, Language and Music and BRAMS, Department of Psychology, University of Montreal, 1420 Mount Royal Boulevard, Montreal, Canada H3C 3J7

⁴Department of Psychology, University of Toronto Mississauga, 3359 Mississauga Road, Mississauga, Canada L5L 1C6

Musicality can be defined as a natural, spontaneously developing trait based on and constrained by biology and cognition. Music, by contrast, can be defined as a social and cultural construct based on that very musicality. One critical challenge is to delineate the constituent elements of musicality. What biological and cognitive mechanisms are essential for perceiving, appreciating and making music? Progress in understanding the evolution of music cognition depends upon adequate characterization of the constituent mechanisms of musicality and the extent to which they are present in non-human species. We argue for the importance of identifying these mechanisms and delineating their functions and developmental course, as well as suggesting effective means of studying them in human and non-human animals. It is virtually impossible to underpin the evolutionary role of musicality as a whole, but a *multicomponent perspective on musicality* that emphasizes its constituent capacities, development and neural cognitive specificity is an excellent starting point for a research programme aimed at illuminating the origins and evolution of musical behaviour as an autonomous trait.

1. Introduction

Why do we have music? What is music for, and why does every human culture have it? Is it a uniquely human capability, as language is? Are some of its fundamental components present in non-human animals? What biological and cognitive mechanisms are essential for perceiving, appreciating and making music?

Some years ago, it became popular to address such questions from an evolutionary perspective [1–5], but disagreement remains about whether music is grounded in our biology, whether it played a role in our survival as a species and, if so, whether musicality resulted from natural or sexual selection.

Steven Pinker provided the most influential critique of music as an adaptation: 'As far as biological cause and effect are concerned, music is useless. (...) Music could vanish from our species and the rest of our lifestyle would be virtually unchanged' and 'it is a technology, not an adaptation' [6, pp. 528–529]. These words, including the reference to music as 'auditory cheesecake'—a mere pleasure-producing substance—revitalized interest in the origins of music and its relevance for the biological and cognitive sciences [7–11].

At least three adaptationist accounts of music have been proposed [12–15]. Charles Darwin first suggested a role for sexual selection in the origins of music [16], a view that was revived and elaborated in recent years [17,18]. For Darwin, music had no survival benefits but it offered a means of impressing potential partners, thereby contributing to reproductive success. He, like other subsequent scholars [13,19], argued that musical vocalizations preceded language.

Another view considers music to have its origins in carers' music-like vocalizations to infants, which are thought to enhance parent–infant bonds, ease the burdens of caregiving and promote infant well-being and survival [14,20]. Such

vocalizations are considered to have paved the way for language as well as music [19].

A third view stresses the role of music in promoting and maintaining group cohesion. Music is thought to be the 'social glue' that enhances cooperation and strengthens feelings of unity [15,21]. According to Dunbar [22], group singing and dancing in our hominin ancestors replaced social grooming (i.e. grooming of others involving touch) as a means of maintaining social connections as groups expanded in size. Song and dance mimic the neurochemical effects of social grooming, such as endorphin release [23], which have important social consequences.

A prominent non-adaptationist view considers music as a technology or 'transformative invention' that makes use of existing skills and has important consequences for our culture and biology [24]. This notion has parallels to the transformative control of fire by early humans, making it possible to cook food and obtain warmth, which had important cultural and biological consequences [25]. Viewed in this manner, music is an exaptation, spandrel or evolutionary by-product of other skills.

The possible adaptive function of music is one of several indispensable levels of analysis of cognitive and biological phenomena that might underlie musicality. In addition to the possible survival or reproductive value of music (adaptation), one can examine the neurobiological substrates (mechanisms), their developmental trajectory (ontogeny) and their evolutionary history (phylogeny) [26]. Accordingly, one can study various levels of information processing relevant to the perceptual and cognitive processing of music [27] or find support for the cognitive and biological origins of music in psychological, physiological, genetic, medical, phylogenetic, hunter-gatherer and cross-cultural perspectives (cf. [28]). These divergent perspectives are necessary for understanding the full complexity of music and musicality, making the study of musicality a truly interdisciplinary endeavour.

Before proposing a *multicomponent perspective* on the origins of musicality, we discuss the notions of biology and culture, music and musicality, as well as important methodological issues. Finally, we outline a number of issues that are vital to advancing the scientific study of musicality.

2. Biology and culture

Until relatively recently, most scholars were wary of the notion that music could have a biological basis:

There is no reason to believe there is a universally shared, innate basis for music perception. Although the possible survival value of music has often been speculated about, music has not been around long enough to have shaped perceptual mechanisms over thousands of generations. Clearly, music is a cultural artifact, and knowledge about it must be acquired. Moreover, in contrast to speech, this knowledge is acquired relatively slowly and not equally by all individuals of a given nature. [29, p. 260]

This position is typical of scholarly thought in musicology over the last 50 years, with music viewed as a cultural product with no evolutionary history and no biological constraints on its manifestation.

The available fossil record dates musical activity to at least 45 000 years ago [30,31], which is a modest time frame in evolutionary terms. It is impossible, however, to conclude that music has not been around long enough to shape perception or cognition. Vocal music and percussive use of the body

leave no physical traces, so the archaeological record can only provide evidence of musical instruments and only those instruments made of durable material such as bone. Opposing claims that 'we may safely infer that music is among the most ancient of human cognitive traits' [32, p. 10 430] are equally indefensible. For the moment, at least, definitive conclusions about the prehistory and origins of music cannot be formulated.

Many scholars embrace Western perspectives on music, viewing music as the exclusive domain of professional musicians who have honed their skills with years of practice [33]. Such approaches are obviously inappropriate for considering the music of all cultures and time periods. Instead of music being *special* or for highly trained individuals, there is increasing evidence that humans share a predisposition for music, especially when the focus is perception rather than production. To recognize a melody and move to (or perceive) the beat of music are trivial skills for most humans and, at the same time, fundamental to our musicality [20,34]. Even infants and young children are sensitive to a number of musical features that are common across cultures [35–38]. Although we are learning more and more about our own musical skills [39,40], the biological origins and evolutionary history of these apparent predispositions remain unclear.

Before discussing prospects for studying the evolution of musicality, we address the notions of music and musicality that are central to this volume.

3. Music and musicality

Definitional issues are especially problematic because there are no conventional defining criteria of music. Within a culture, people agree, more or less, on what constitutes music, but there is considerably less agreement across cultures. Venturing across species is even more contentious. Although some contend that the songs of some birds (e.g. nightingales), those of humpback whales, a Thai elephant orchestra or the interlocking duets of gibbons are examples of music (cf. [1]), most would argue, instead, that human listeners can use a musical frame of reference to make many sound patterns seem musical. A more productive perspective is to consider the basic components of musicality and the extent to which we share those components with various non-human animals.

Addressing these issues productively depends on distinguishing between the notions of music and musicality [28,31,35]. *Musicality* in all its complexity can be defined as a natural, spontaneously developing set of traits based on and constrained by our cognitive and biological system. *Music* in all its variety can be defined as a social and cultural construct based on that very musicality. This distinction demarcates two divergent approaches to the cognition and biology of music.

One approach is to study the *structure of music*, seeking key similarities and differences in musical form and activity across a variety of human cultures [41,42]. Although there is no widely shared definition of music [43], the presence of several cross-cultural similarities supports the notion of musicality as a prominent characteristic of humankind. The similarities are suggestive of underlying cognitive and biological mechanisms that may constrain and shape musical behaviours across cultures.

An alternative approach is to study the *structure of musicality* by attempting to identify the basic underlying

mechanisms, cognitive and biological, their function and developmental course, and effective ways to study those mechanisms in human and non-human animals. The major challenge of this approach, and of the current issue, is to delineate the traits that constitute the musicality phenotype.

4. Evolution of (music) cognition

There is much scepticism about the possibility of gaining insight into the evolution of cognition in general [28,44,45] and, by extension, musicality. According to Lewontin [44], evolutionary theory stands on three principles—variation, heredity and natural selection—that limit scientific inquiry into cognition. To understand the evolution of cognition, it is necessary to understand the variation in cognitive traits in ancestral times. Because cognition does not fossilize, we cannot acquire the requisite evidence about variability [44]. On the issue of heritability, many studies provide such evidence (see Gingras *et al.* [46]), but it is difficult to specify the genes because cognitive traits are polygenic. It is also important to gather evidence about the possibility that cognitive traits were the target of natural selection. Without reconstructing the minds of our hunter–gatherer predecessors, for example, we can only guess at the selection pressures they faced [47].

Despite the apparent impossibility of studying the evolution of complex mental processes such as cognition, we argue that a bottom-up approach involving the search for basic mechanisms that combine into a multicomponent trait like musicality can be fruitful. Such an approach has resulted in important insights in the domains of animal cognition [48–50] and the evolution of language [51].

5. Multicomponent perspective

Some cognitive functions like language and music are viewed as typically human. It is possible, however, that other species share one or more component mechanisms of musicality. A bottom-up perspective [52] focusing on the constituent capacities underlying musicality could reveal such common mechanisms. Instead of asking which species are musical, we ask how musicality works, its essential ingredients, which ingredients are shared with other species, and how these evolved.

In essence, we are combining functional, developmental, phylogenetic and mechanistic approaches [26] to generate a theory of musicality while focusing on the constituent capacities underlying the musicality phenotype. In fact, we propose to address Tinbergen's [26] four questions by first describing the mechanisms, functions and developmental course of musicality in a variety of animals and cultures, with input from anthropological, neuroscientific and genetic sources. By doing so, we hope to learn more about how music evolved.

A *multicomponent perspective*, which involves studying the constituents of musicality in the 'here and now' by means of a comparative approach across cultures and species, is one means of addressing the critique that the evolution of musicality cannot be studied (§4). This approach is based on the neo-Darwinian assumption that if closely related species, whether humans and apes or walrus and sea lions, exhibit similar solutions to similar problems, they are probably engaging similar mechanisms (figure 1). When two species share a particular musical trait, one can infer that their common

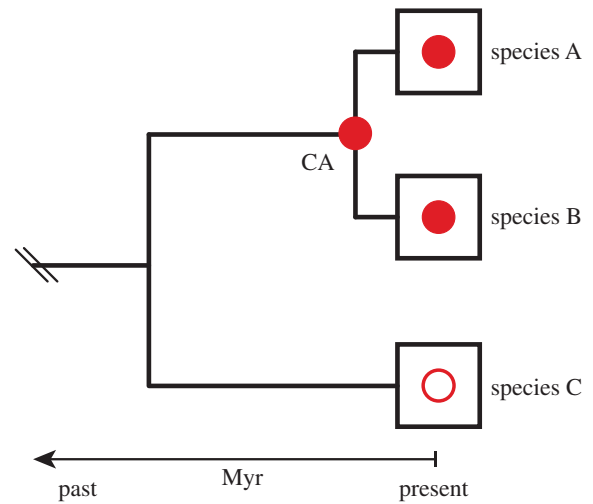

Figure 1. Neo-Darwinian perspective on the evolution of musicality. Diagrammatic representation of a hypothetical phylogenetic tree illustrating the Darwinian assumption that closely related species share similar traits. When two species (A and B) share a certain musical trait, one can infer that their CA also had that trait (referred to as a homologous trait). Filled circles represent a trait; open circles indicate the absence of that trait. (Online version in colour.)

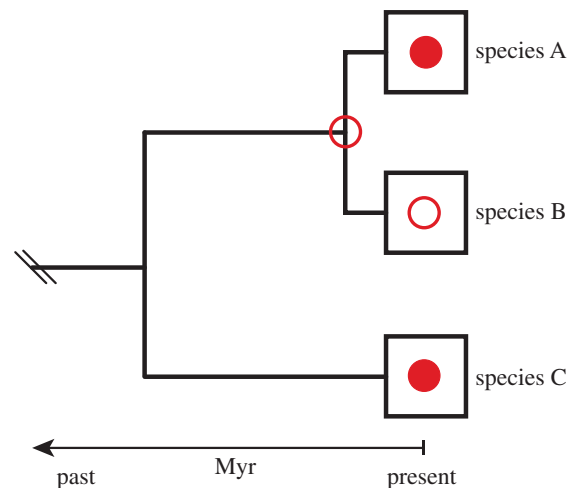

Figure 2. Convergent evolution of musicality. Diagrammatic representation of a hypothetical phylogenetic tree illustrating an analogous trait (homoplasy) in which a distant species (C compared to A) developed a musical trait that is lacking in a more closely related species (B compared to A). Filled circles represent a trait; open circles indicate the absence of that trait. (Online version in colour.)

ancestor (CA) also had that trait. By examining these homologous traits in a natural group of species (i.e. clade), one can date the origin of that particular trait. This is the principal motivation for studying music perception in closely related species [53].

Species that are closely related to humans can be assumed to share some cognitive abilities and might therefore be good experimental models for teasing apart various neurological, genetic or epigenetic contributions to a certain trait. The study of more distant or unrelated species that share a similar trait (that is not homologous) can also contribute to an understanding of underlying mechanisms. The convergent evolution of particular traits in distant species (analogous trait or homoplasy; figure 2) is the main motivation for studying music perception in such species [54].

The study of homologous and analogous traits is the key tool of comparative biology. Although an observable phenotype

Table 1. Some key questions for a future research agenda on musicality.

- (1) What is the most promising means of carving musicality into component skills?
- (2) What kinds of natural behaviour in other species might be related to musicality?
- (3) How can we more clearly differentiate biological and cultural contributions to musicality?
- (4) What is the neuronal circuitry associated with different aspects of musicality?
- (5) How do the relevant genes contribute to building a musical brain (i.e. using functional studies to bridge the gap between genes, neurons, circuits and behaviour)?
- (6) Can we use such genes to trace the evolutionary history of our musical capacities in human ancestors and to study parallels in non-human animals?
- (7) Can non-human animals detect higher order patterns in sounds (e.g. auditory grouping), as humans do?
- (8) Is entrainment or beat induction restricted to species capable of vocal learning?
- (9) Can non-human animals generalize across timbres?
- (10) Do absolute and relative processing of pitch, duration and timbre depend on context, stimuli or species?
- (11) How can we study the evolution of musicality relative to language?

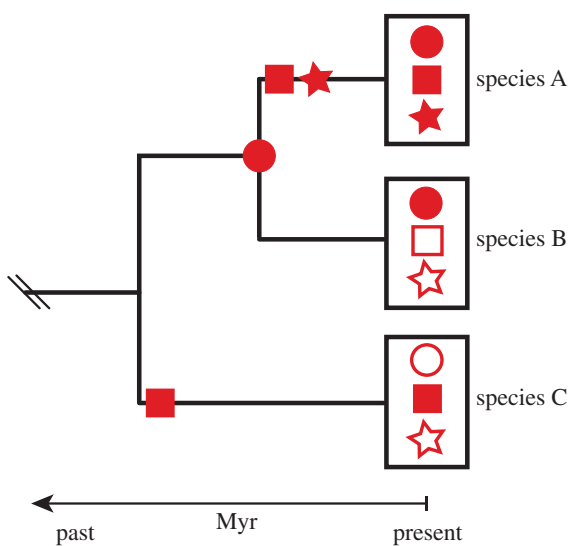

Figure 3. Multicomponent perspective on musicality. Diagrammatic representation of the evolution of the musicality phenotype. It illustrates the hypothesized contributions of several traits to musicality as a complex or *multicomponent* phenotype. Filled shapes represent the presence of a trait; open shapes indicate the absence of that trait. Shapes that are positioned on the tree are hypothesized dates of origin of that trait. (Online version in colour.)

might have evolved independently in different lineages (i.e. a CA lacked such a phenotype), it is possible that this trait involves a ‘deep homology’ in which distant species share underlying genetic and developmental mechanisms that generated the trait [55]. Consider the role of the *FOXP2* gene in the vocal learning mechanisms of humans and songbirds [56]. Further research into neural mechanisms and biological substrates is necessary to pinpoint the mechanisms that are essential to musicality. This can reveal the extent to which humans share some of the components of musicality with other species and will inform a phenomics of musicality [46].

Combining these views, we propose to study musicality as a composite of several traits, each with its own underlying neural mechanisms and evolutionary history (figure 3) that can be studied at the present time (avoiding the critique in §4). Potential candidates for the basic components of musicality are relative pitch [2,35], tonal encoding of pitch [57], beat perception [34,58] and metrical encoding of rhythm [58].

Some of these traits may be common to humans and other species, with others being uniquely human.

In summary, the research agenda for studying the cognitive, biological, cultural and social origins of musicality (and the aim of this Theme Issue) is twofold. The primary aim is to identify the basic mechanisms that contribute to musicality, their functions and developmental course, as well as effective ways to study them in human and non-human animals. A secondary aim is to constrain evolutionary theories of musicality by evaluating recent findings from the fields of biology, musicology, neurology, genetics, computer science, anthropology and psychology.

6. Lorentz workshop on musicality and its relation to this theme issue

During a Lorentz Workshop on this subject (from which this issue arose), held in April 2014, it became clear that reframing the available empirical evidence and proposing a research agenda on musicality were both important and timely. Moreover, 23 experts from a wide range of disciplines (cognitive biology, cognitive neuroscience, neurobiology, animal cognition, molecular genetics, anthropology, developmental psychology and computational cognition) agreed on many facets of such a research agenda, providing the momentum for this theme issue.

Together, the papers assembled in this issue set a research agenda for the study of musicality in the years to come, an endeavour that is multidisciplinary, as is the background of the authors. The topics of the 11, mostly co-authored, papers resulted from a bottom-up selection process during the workshop, prompted by a series of position statements and reviews. These topics formed the basis of Working Sessions in which the key ingredients of the papers were formulated.

Below we introduce and discuss each selected topic, its history and the resulting paper. In table 1, we summarize the key questions for a future research agenda on musicality.

(a) Four principles of bio-musicology

The first paper in this issue is one of four position papers that outline the key issues in the study of musicality. Tecumseh

Fitch [59] proposes four principles as prerequisites for a future discipline of 'bio-musicology', a term coined by Nils L. Wallin [1] to encompass several branches of music psychology and musicology, but that is used here to refer to the biological study of musicality in all its forms.

In addition to these four principles, which incorporate Tinbergen's four ethological questions, the paper argues for a revitalized search for musical universals, a topic that has been explored extensively by scholars such as Bruno Nettl [60] and, more recently, by Brown and Jordania [61].

Some of these ideas are widely accepted in one or more disciplines, like the multicomponent approach or Tinbergen's four levels of explanation. Others have less agreement, like the notion of universals of musical structure (cf. [43]) or the focus on overt behaviour (cf. [54]).

Fitch continues by proposing four core components of musicality, which differ somewhat from the four components proposed in this paper. Instead of the current focus on perceptual and cognitive mechanisms that might be fundamental to musicality (e.g. relative pitch, beat perception, tonal encoding of pitch and metrical encoding of rhythm; §5), he argues for four musical behaviours as the central focus of bio-musicology: song, drumming, social synchronization and dance. In so doing, he suggests a bridge from cognitive biology to fields like anthropology and social psychology. In short, he proposes bio-musicology as a rich field for interdisciplinary and comparative research on musicality.

(b) The origins of music in auditory scene analysis and the roles of evolution and culture in musical creation

Trainor [62] considers the possibility that music originated either as an evolutionary adaptation or as a product of culture. The uniqueness of music to humans, its universality across cultures and its early emergence in development are consistent with music as an evolutionary adaptation. However, the flexibility and generativity of music and its rapid change over time are consistent with cultural transmission rather than adaptation. According to Trainor, adaptation and cultural transmission underlie the origins of music. Although the processing of musical pitch and timing are presumed to have evolutionary origins, she argues that they did not evolve specifically for music but rather for identifying and locating sounding objects in the environment (i.e. auditory scene analysis [63]). In other words, the creation of music capitalized on preexisting auditory processes. Trainor argues, however, that the emotional and social consequences of music may have conferred survival benefits, leading to adaptations that promoted and enhanced musical behaviour.

(c) Searching for the origins of musicality across species

Hoeschele *et al.* [54] pose critical questions such as what species to study and how to study them in searching for the components of musicality and their biological origins. They outline the contributions of artificial laboratory experiments to our understanding of various aspects of musicality such as absolute and relative pitch processing, rhythm processing and timbre processing. They also indicate how studies of the natural behaviour of species have revealed important skills relating to musicality and have also informed laboratory studies. For example, detailed descriptions of the songs of

black-capped chickadees—their variability [64] and the preferences of female conspecifics [65]—revealed the relative pitch processing capabilities of this species, prompting training studies that delineated the limits of these abilities [66]. The authors suggest new directions for future research, including the search for musically relevant behaviours in species that have received little attention to date and the use of more ecologically valid stimuli and tasks in the laboratory.

(d) Five fundamental constraints on theories of the origins of music

The uniqueness and universality of music raise questions of how and why the human ability to appreciate and produce music evolved. To avoid 'just-so stories' for the evolution of music, Merker *et al.* [67] argue for constraints on evolutionary theorizing. They propose five such constraints, chosen for their generality and their consequences for the structure of music: (i) cultural transmission, so that any transfer of musical traits must pass through an inter-generational 'learner bottleneck'; (ii) generativity, such that music can generate infinite pattern diversity by finite means; (iii) vocal production learning; (iv) entrainment with perfect synchrony; and (v) a motivational basis for the universal human propensity to sing and dance together in a group. Some of these constraints are not specific to music, with the first three being applicable to the evolution of language. Like other contributors to this issue, these authors draw parallels between language and music processing. They suggest that some distinguishing features of music do not require Darwinian explanations for their widespread occurrence, arising instead from constraints and characteristics of the learning mechanisms involved. Other features may be subject to Darwinian selection. In those cases, it is important to consider the modes of selection that might be operative as well as the features on which they are operative, the latter issue often receiving insufficient attention.

(e) Cross-cultural perspectives on music and musicality

This paper by Trehub *et al.* [43] issues an invitation to conduct more socially oriented research on music cognition as it may hold keys to the evolutionary origins of musicality. It is proposed that music promotes social and pro-social behaviour through a variety of mechanisms such as jointly experienced arousal and synchronous action across cultures. The argument is original and thought-provoking. For example, the paper covers musical universals from a fresh perspective. One universal, which is particularly novel and interesting, is repetition (of motifs and themes). Repetition is ubiquitous in music and has no clear parallel in language. Similarly, the paper presents vivid examples of social behaviours that may be akin to what is experienced while being musically engaged in a group. A vivid example is the empathy and arousal elicited by watching fire-walkers, in particular those who are relatives or friends. In sum, the authors make a convincing case for further study of the social aspects of musical engagement, which may account for the perpetuation of music. Music may outperform language in this respect because it can be shared simultaneously with more individuals and over longer distances than can speech.

(f) Neural overlap in processing music and speech

While there is a growing literature on the relationship between music and language, especially with regard to the underlying

brain processes that facilitate music and speech (cf. [63]), there are at least four competing views on how music and speech are processed in the brain: (i) music and speech make use of identical brain networks (*identity hypothesis*), (ii) music and speech processing occur in overlapping brain regions (*neural sharing hypothesis*), (iii) music and speech have neural overlap but do not share neural circuitry (*neural overlap hypothesis*) or (iv) they are distinct (*dissociation hypothesis*).

The paper by Peretz *et al.* [68] elaborates the third hypothesis that stresses the distinction between brain locations and brain networks. The authors argue that part of the neural circuitry that has been established for language may have been recycled during evolution for musicality or, alternatively, that musicality served as a springboard for the emergence of language.

In the second half of this paper, Peretz *et al.* review some of the evidence in support of this interpretation, suggesting methods for disentangling neural overlap and neural sharing perspectives on music and language. While the neural overlap hypothesis is an attractive alternative to the neural sharing hypothesis (cf. [64]), the idea of neuronal recycling as applied to the evolution of musicality needs further research. Interestingly, if a core component of musicality is found to share a brain region or network involved in language, it may reveal a novel pathway by which some animals, most notably humans, achieved their highly sophisticated use of sound.

(g) Defining the biological bases of individual differences in musicality

Humans differ in their music-related skills, as they do for most other skills. While some of this variation is clearly linked to experiential differences, including exposure and training, there is accumulating evidence for the involvement of genetic variation and an emerging consensus that musicality has deep biological foundations. The impressive advances in molecular technologies have made it possible to explore these foundations.

Gingras *et al.* [46] provide a synthesis of research on the genetic correlates of musicality and the methods by which current insights have emerged. Entry points for exploring the genetic basis of components of musicality range from the examination of clustering in families or co-occurrence in twins of extreme levels of ability, like congenital amusia or absolute pitch perception, to genome-wide genotyping to capture the polymorphic content of a large phenotyped population sample, using advanced genomic and statistical methods. They sketch the prospects of new technologies for tracing the effects of particular genes on musicality. Moreover, they provide concrete suggestions for online test procedures that may improve the phenotyping of musical abilities and that can be combined with genome-wide genotype data on specific human populations.

(h) Finding the beat: a neuro-computational approach

One of the core mechanisms of musicality, as acknowledged by contributors to this issue, is the ability to perceive and synchronize movements to the beat of music. This skill is variously termed beat perception and synchronization [65], beat induction [66], or pulse perception and entrainment [58]. The skill is spontaneously developing [38], music-specific [69] and present in humans [58] but apparently lacking in other primates.

Merchant *et al.* [53] review the ever-increasing literature on beat perception and entrainment in monkeys, apes and humans [70]. They evaluate several brain imaging methods, including functional and electrophysiological techniques, for investigating the underlying mechanisms. The neurophysiology of rhythmic behaviour is also discussed, informed largely by recent findings in monkeys using direct intracortical [71] and non-invasive techniques [72].

Finally, the authors address the consequences of these findings for computational models of beat induction. Computational modelling is a long-standing promise of cognitive science, so a concrete mechanism like beat perception seems ideal for revealing the network required for perceiving regularity. The authors suggest questions that should be addressed in the near future.

(i) Principles of structure building in music, language and animal vocalization

This paper by Rohrmeier *et al.* [73] brings together a thorough review of the literatures on animal song, music and formal models of language. It provides an overview of the Chomsky hierarchy and discusses a number of ways in which formal language models can be extended. Throughout, it suggests links to language, music and animal vocalization. Interestingly, like Trehub *et al.* [43], the authors ground their discussion of building blocks on Brown and Jordania's recent work on cross-cultural universals in music [61], including repetition. By doing so, they strengthen the importance of a cross-cultural perspective and point to limitations of other approaches. The rough tutorial material on grammar formalisms provides an important service for scholars of musicality. The paper should be useful to researchers from various fields of inquiry, prompting the possibility of new and fruitful connections.

(j) Affect induction through musical sounds: an ethological perspective

Music often induces emotional responses in listeners, some of which seem to be universal and others not. Huron [74] explores these phenomena by drawing upon parallels from animal communication. For example, there is often a close linkage within a species between an evolved signal and the response it evokes. Variation in a particular signal within and among species is sometimes tightly linked to physiological constraints. For example, the production of low-pitched sounds is often linked to a large body size or resonance cavity. Low pitch may have been selected as a threat signal providing honest information about the size and potential strength of the sender. For the receiver, such a signal might evoke fear. These and other evolved associations might be used in music to induce emotion in listeners.

Huron addresses five so-called 'puzzles' regarding music-induced emotions: Why can music induce certain emotions but not others? Why are some induced emotions similar to the displayed emotions in some cases but not others? Why do listeners often report feeling mixed emotions? Why are some emotions similar across musical cultures while others are not? And why do musicians rely on some emotion-inducing mechanisms more than others? Huron uses concepts and mechanisms from animal communication studies to explore why specific associations between sounds and emotions are more or less likely.

(k) The evolutionary roots of creativity: mechanisms and motivations

Wiggins *et al.* [75] endeavour to relate creativity and its principles, as exercised in human music, to parallels in other species as a means of shedding light on the evolution of cognition and the emergence of creative behaviour. This endeavour entails analysis of creativity at the phenomenological level. The authors decompose creativity into an objective process of generation, coupled with a combination of relative value judgements, some of which, notably novelty, can be modelled objectively. One unbiased approach to novelty is to identify it in non-human animals. For example, non-human creativity can be found in the novelty of humpback whale singing in Australia and the Pacific. A similar argument can be made for birdsong. In sum, the authors make a case for considering creativity as an evolutionary pressure, proposing a research programme involving animal communication (bird and whale song, specifically) to investigate this possibility.

Acknowledgements. H.H. would like to thank all staff at both the Lorentz Center and the Netherlands Institute for Advanced Study in the Humanities and Social Sciences (NIAS) for their enthusiastic contributions (direct and indirect) to the fellowship and the associated international workshop. This paper is based on talks given by the authors at the 'What Makes Us Musical Animals? Cognition, Biology and the Origins of Musicality' workshop held from 7 to 11 April 2014 at The Lorentz Center, Leiden, The Netherlands. It is also based on a keynote address by the first author (H.H.) at the Evolution of Music Workshop (EvoMus) at the University of Vienna on 14 April 2014. H.H. wrote the initial draft of the paper. C.t.C., I.P. and S.T. provided feedback and contributed to various sections. All authors contributed to the overall framework of the paper and edited the final manuscript.

Funding statement. H.H. is supported by a Distinguished Lorentz fellowship granted by the Lorentz Center for the Sciences and the NIAS. I.P. is supported by the Natural Sciences and Engineering Research Council of Canada, the Canadian Institutes of Health Research and a Canada Research Chair. S.T. is supported by the Natural Sciences and Engineering Research Council of Canada and the Social Sciences and Humanities Research Council of Canada.

Competing interests. The authors have no competing interests.

References

- Wallin N, Merker B, Brown S. 2000 *The origins of music*. Cambridge, MA: MIT Press.
- Justus T, Hutsler J. 2005 Fundamental issues in the evolutionary psychology of music: assessing innateness and domain specificity. *Music Percept.* **23**, 1–27. (doi:10.1525/mp.2005.23.1.1)
- McDermott JH, Hauser MD. 2005 The origins of music: innateness, uniqueness, and evolution. *Music Percept.* **23**, 29–59. (doi:10.1525/mp.2005.23.1.29)
- Cross I. 2007 Music and cognitive evolution. In *Oxford handbook of evolutionary psychology* (eds RIM Dunbar, L Barrett), pp. 649–667. Oxford, UK: Oxford University Press.
- Vitouch O, Ladinin O. 2009 Preface to special issue. Music and evolution. *Music Sci.* **13**, 7–11. (doi:10.1177/1029864909013002021)
- Pinker S. 1997 *How the mind works*. New York, NY: Norton.
- Huron D. 2001 Is music an evolutionary adaptation? *Ann. NY Acad. Sci.* **930**, 43–61. (doi:10.1111/j.1749-6632.2001.tb05724.x)
- Mithen SJ. 2009 The music instinct: the evolutionary basis of musicality. *Ann. NY Acad. Sci.* **1169**, 3–12. (doi:10.1111/j.1749-6632.2009.04590.x)
- Zatorre RJ. 2005 Music: the food of neuroscience? *Nature* **434**, 312–315. (doi:10.1038/434312a)
- Ashley R, Hutchins S, Palmer C, Hannon EE. 2006 Music and cognition: what cognitive science can learn from music cognition. In *Proc. XXVIII Annu. Conf. of the Cognitive Science Society, 26–29 July 2006, Vancouver, Canada*. p. 2655. Wheat Ridge, CO: Cognitive Science Society.
- Pearce M, Rohrmeier M. 2012 Music cognition and the cognitive sciences. *Top. Cogn. Sci.* **4**, 468–484. (doi:10.1111/j.1756-8765.2012.01226.x)
- Darwin C. 1859 *On the origin of species*. London, UK: John Murray.
- Mithen SJ. 2005 *The singing Neanderthals: the origins of music, language, mind, and body*. Cambridge, MA: Harvard University Press.
- Dissanayake E. 2008 If music is the food of love, what about survival and reproductive success? *Music Sci.* **12**, 169–195. (doi:10.1177/1029864908012001081)
- Cross I. 2009 The nature of music and its evolution. In *Oxford handbook of music psychology* (eds S Hallam, I Cross, M Thaut), pp. 3–13. Oxford, UK: Oxford University Press.
- Darwin C. 1871 *The descent of man, and selection in relation to sex*. London, UK: John Murray.
- Miller GF. 2000 Evolution of human music through sexual selection. In *The origins of music* (eds NL Wallin, B Merker, S Brown), pp. 329–360. Cambridge, MA: MIT Press.
- Merker B. 2000 Synchronous chorusing and human origins. In *The origins of music* (eds NL Wallin, B Merker, S Brown), pp. 315–327. Cambridge, MA: MIT Press.
- Brown S. 2000 The 'Musilanguage' model of music evolution. In *The origins of music* (eds NL Wallin, B Merker, S Brown), pp. 271–300. Cambridge, MA: MIT Press.
- Honing H. 2013 *Musical cognition: a science of listening*. New Brunswick, NJ: Transaction Publishers.
- Merker BH, Madison GS, Eckerdal P. 2009 On the role and origin of isochrony in human rhythmic entrainment. *Cortex* **45**, 4–17. (doi:10.1016/j.cortex.2008.06.011)
- Dunbar RIM. 2012 On the evolutionary function of song and dance. In *Music, language, and human evolution* (ed. N Bannan), pp. 201–214. Oxford, UK: Oxford University Press.
- Dunbar RIM. 2010 The social role of touch in humans and primates: behavioural function and neurobiological mechanisms. *Neurosci. Biobehav. Rev.* **34**, 260–268. (doi:10.1016/j.neubiorev.2008.07.001)
- Patel AD. 2010 Music, biological evolution, and the brain. In *Emerging disciplines* (eds C Levander, C Henry), pp. 91–144. Houston, TX: Rice University Press.
- Wrangham R, Conklin-Brittain N. 2003 Cooking as a biological trait. *Comp. Biochem. Physiol. A Mol. Integr. Physiol.* **136**, 35–46. (doi:10.1016/S1095-6433(03)00020-5)
- Tinbergen N. 1963 On aims and methods of ethology. *Z. Tierpsychol.* **20**, 410–433. (doi:10.1111/j.1439-0310.1963.tb01161.x)
- Marr D. 1982 *Vision: a computational investigation into the human representation and processing of visual information*. Cambridge, MA: MIT Press.
- Honing H, Ploeger A. 2012 Cognition and the evolution of music: pitfalls and prospects. *Top. Cogn. Sci.* **4**, 513–524. (doi:10.1111/j.1756-8765.2012.01210.x)
- Repp BH. 1991 Some cognitive and perceptual aspects of speech and music. In *Music, language, speech and brain* (eds J Sundberg, L Nord, R Carlson), pp. 257–268. Stockholm, Sweden: MacMillan Press.
- Conard NJ, Malina M, Münzel SC. 2009 New flutes document the earliest musical tradition in southwestern Germany. *Nature* **460**, 737–740. (doi:10.1038/nature08169)
- Morley I. 2013 *The prehistory of music: human evolution, archaeology, and the origins of musicality*. Oxford, UK: Oxford University Press.
- Zatorre RJ, Salimpoor VN. 2013 From perception to pleasure: music and its neural substrates. *Proc. Natl Acad. Sci. USA* **110**, 10 430–10 437. (doi:10.1073/pnas.1301281110)
- Blacking J. 1973 *How musical is man? (The John Danz Lectures)*. Seattle, WA: University of Washington Press.
- Honing H. 2012 Without it no music: beat induction as a fundamental musical trait. *Ann. NY Acad. Sci.* **1252**, 85–91. (doi:10.1111/j.1749-6632.2011.06402.x)
- Trehub SE. 2003 The developmental origins of musicality. *Nat. Neurosci.* **6**, 669–673. (doi:10.1038/nn1084)

36. Hannon EE, Trehub SE. 2005 Metrical categories in infancy and adulthood. *Psychol. Sci.* **16**, 48–55. (doi:10.1111/j.0956-7976.2005.00779.x)
37. Trainor LJ, Trehub SE. 1992 A comparison of infants' and adults' sensitivity to Western musical structure. *J. Exp. Psychol. Hum. Percept. Perform.* **18**, 394–402. (doi:10.1037/0096-1523.18.2.394)
38. Winkler I, Háden GP, Ladinig O, Sziller I, Honing H. 2009 Newborn infants detect the beat in music. *Proc. Natl Acad. Sci. USA* **106**, 2468–2471. (doi:10.1073/pnas.0809035106)
39. Deutsch D. 2013 *The psychology of music*. Amsterdam, The Netherlands: Elsevier.
40. Hallam S, Cross I, Thaut M. 2009 *Oxford handbook of music psychology*. Oxford, UK: Oxford University Press.
41. Nettl B. 2006 Response to Victor Grauer: on the concept of evolution in the history of ethnomusicology. *World Music* **48**, 59–72.
42. Lomax A, Berkowitz N. 1972 The evolutionary taxonomy of culture. *Science* **177**, 228–239. (doi:10.1126/science.177.4045.228)
43. Trehub SE, Becker J, Morley I. 2015 Cross-cultural perspectives on music and musicality. *Phil. Trans. R. Soc. B* **370**, 20140096. (doi:10.1098/rstb.2014.0096)
44. Lewontin R. 1998 The evolution of cognition: questions we will never answer. In *An invitation to cognitive science, volume 4: methods, models, and conceptual issues* (eds D Scarborough, S Sternberg), pp. 107–131. Cambridge, MA: MIT Press.
45. Bolhuis JJ, Wynne CDL. 2009 Can evolution explain how minds work? *Nature* **458**, 832–833. (doi:10.1038/458832a)
46. Gingras B, Honing H, Peretz I, Trainor LJ, Fisher SE. 2015 Defining the biological bases of individual differences in musicality. *Phil. Trans. R. Soc. B* **370**, 20140092. (doi:10.1098/rstb.2014.0092)
47. Richardson R. 2007 *Evolutionary psychology as maladapted psychology*. Cambridge, MA: MIT Press.
48. De Waal FBM, Ferrari PF. 2012 *The primate mind*. Cambridge, MA: Harvard University Press.
49. Shettleworth SJ. 2010 *Cognition, evolution, and behavior*. London, UK: Oxford University Press.
50. Call J, Tomasello M. 2008 Does the chimpanzee have a theory of mind? 30 years later. *Trends Cogn. Sci.* **12**, 187–192. (doi:10.1016/j.tics.2008.02.010)
51. Fitch WT. 2010 *The evolution of language*. Cambridge, MA: Cambridge University Press.
52. De Waal FBM, Ferrari PF. 2010 Towards a bottom-up perspective on animal and human cognition. *Trends Cogn. Sci.* **14**, 201–207. (doi:10.1016/j.tics.2010.03.003)
53. Merchant H, Grah J, Trainor L, Rohrmeier M, Fitch WT. 2015 Finding the beat: a neural perspective across humans and non-human primates. *Phil. Trans. R. Soc. B* **370**, 20140093. (doi:10.1098/rstb.2014.0093)
54. Hoesele M, Merchant H, Kikuchi Y, Hattori Y, ten Cate C. 2015 Searching for the origins of musicality across species. *Phil. Trans. R. Soc. B* **370**, 20140094. (doi:10.1098/rstb.2014.0094)
55. Shubin N, Tabin C, Carroll S. 2009 Deep homology and the origins of evolutionary novelty. *Nature* **457**, 818–823. (doi:10.1038/nature07891)
56. Fisher SE, Scharff C. 2009 FOXP2 as a molecular window into speech and language. *Trends Genet.* **25**, 166–177. (doi:10.1016/j.tig.2009.03.002)
57. Peretz I, Coltheart M. 2003 Modularity of music processing. *Nat. Neurosci.* **6**, 688–691. (doi:10.1038/nn1083)
58. Fitch WT. 2013 Rhythmic cognition in humans and animals: distinguishing meter and pulse perception. *Front. Syst. Neurosci.* **7**, 1–16. (doi:10.3389/fnsys.2013.00068)
59. Fitch WT. 2015 Four principles of bio-musicology. *Phil. Trans. R. Soc. B* **370**, 20140091. (doi:10.1098/rstb.2014.0091)
60. Nettl B. 2000 An ethnomusicologist contemplates universals in musical sound and musical culture. In *The origins of music* (eds NL Wallin, B Merker, S Brown), pp. 463–472. Cambridge, MA: MIT Press.
61. Brown S, Jordania J. 2011 Universals in the world's musics. *Psychol. Music* **41**, 229–248. (doi:10.1177/0305735611425896)
62. Trainor LJ. 2015 The origins of music in auditory scene analysis and the roles of evolution and culture in musical creation. *Phil. Trans. R. Soc. B* **370**, 20140089. (doi:10.1098/rstb.2014.0089)
63. Arbib MA. 2013 *Language, music, and the brain: a mysterious relationship*. Cambridge, MA: MIT Press.
64. Patel AD. 2011 Why would musical training benefit the neural encoding of speech? The OPERA hypothesis. *Front. Psychol.* **2**, 142. (doi:10.3389/fpsyg.2011.00142)
65. Patel AD. 2014 The evolutionary biology of musical rhythm: was Darwin wrong? *PLoS Biol.* **12**, e1001821. (doi:10.1371/journal.pbio.1001821)
66. Honing H. 2013 Structure and interpretation of rhythm in music. In *Psychology of music* (ed. D Deutsch), pp. 369–404. London, UK: Academic Press.
67. Merker B, Morley I, Zuidema W. 2015 Five fundamental constraints on theories of the origins of music. *Phil. Trans. R. Soc. B* **370**, 20140095. (doi:10.1098/rstb.2014.0095)
68. Peretz I, Vuvar D, Lagrois M-É, Armony JL. 2015 Neural overlap in processing music and speech. *Phil. Trans. R. Soc. B* **370**, 20140090. (doi:10.1098/rstb.2014.0090)
69. Patel AD. 2006 Musical rhythm, linguistic rhythm, and human evolution. *Music Percept.* **24**, 99–104. (doi:10.1525/mp.2006.24.1.99)
70. Mendoza G, Merchant H. 2014 Motor system evolution and the emergence of high cognitive functions. *Prog. Neurobiol.* **122C**, 73–93. (doi:10.1016/j.pneurobio.2014.09.001)
71. Merchant H, Zarco W, Perez O, Prado L, Bartolo R. 2011 Measuring time with different neural chronometers during a synchronization-continuation task. *Proc. Natl Acad. Sci. USA* **108**, 19 784–19 789. (doi:10.1073/pnas.1112933108)
72. Honing H, Merchant H, Háden GP, Prado L, Bartolo R. 2012 Rhesus monkeys (*Macaca mulatta*) detect rhythmic groups in music, but not the beat. *PLoS ONE* **7**, e51369. (doi:10.1371/journal.pone.0051369)
73. Rohrmeier M, Zuidema W, Wiggins GA, Scharff C. 2015 Principles of structure building in music, language and animal song. *Phil. Trans. R. Soc. B* **370**, 20140097. (doi:10.1098/rstb.2014.0097)
74. Huron D. 2015 Affect induction through musical sounds: an ethological perspective. *Phil. Trans. R. Soc. B* **370**, 20140098. (doi:10.1098/rstb.2014.0098)
75. Wiggins GA, Tyack P, Scharff C, Rohrmeier M. 2015 The evolutionary roots of creativity: mechanisms and motivations. *Phil. Trans. R. Soc. B* **370**, 20140099. (doi:10.1098/rstb.2014.0099)