

Yeast Cell Cycle Protein CDC48p Shows Full-Length Homology to the Mammalian Protein VCP and Is a Member of a Protein Family Involved in Secretion, Peroxisome Formation, and Gene Expression

Kai-Uwe Fröhlich, Hans-Werner Fries, Manfred Rüdiger, Ralf Erdmann,* David Botstein,‡ and Dieter Mecke

Physiologisch-chemisches Institut der Universität Tübingen, 7400 Tübingen, Federal Republic of Germany; *Institut für Physiologische Chemie, Ruhr-Universität Bochum, 4630 Bochum 1, Federal Republic of Germany; ‡Department of Genetics, Stanford University, Stanford, California 94305

Abstract. Yeast mutants of cell cycle gene *cdc48-1* arrest as large budded cells with microtubules spreading aberrantly throughout the cytoplasm from a single spindle plaque. The gene was cloned and disruption proved it to be essential. The *CDC48* sequence encodes a protein of 92 kD that has an internal duplication of 200 amino acids and includes a nucleotide binding consensus sequence. Vertebrate VCP has a 70% identity over the entire length of the protein. Yeast Sec18p and mammalian *N*-ethylmaleimide-sensitive fusion protein, which are involved in intracellular transport, yeast Paslp,

which is essential for peroxisome assembly, and mammalian TBP-1, which influences HIV gene expression, are 40% identical in the duplicated region. Antibodies against *CDC48* recognize a yeast protein of apparently 115 kD and a mammalian protein of 100 kD. Both proteins are bound loosely to components of the microsomal fraction as described for Sec18p and *N*-ethylmaleimide-sensitive fusion protein. This similarity suggests that CDC48p participates in a cell cycle function related to that of *N*-ethylmaleimide-sensitive fusion protein/Sec18p in Golgi transport.

THE yeast *Saccharomyces cerevisiae* is a favorite model organism for studying complex physiological pathways at the single cell level such as the cell division cycle, the assembly of cell organelles, or secretory processes. A generalization of the results from yeast depends on significant structural conservation of the components within higher eukaryotic pathways. Ideally, the genes or gene products should be functionally interchangeable between yeast and vertebrates. This has been described for secretion (Dunphy et al., 1986) and cell cycle (e.g., protein kinase Cdc28 from yeast and Cdc2Hs from humans; Wittenberg and Reed, 1989) functions.

A well-characterized example of mutual exchangeability involves the yeast gene product, Sec18p (gene *SEC18*) (Eakle et al., 1988), and NEM-sensitive fusion protein (NSF)¹ from Chinese hamster (Block et al., 1988; Beckers et al., 1989; Diaz et al., 1989). Both proteins are essential for transport between ER and Golgi, as well as between different Golgi cisternae. Both bind to uncoated secretory vesicles and promote their fusion to the next Golgi compartment. NEM (*N*-ethylmaleimide, a thiol reagent) inhibits the fusion activity, whereas ATP is essential for this function and effects

a dissociation of Sec18p or NSF from the vesicles in cell extracts. Sec18p can substitute for NSF in an in vitro transport system derived from hamster cells (Wilson et al., 1989). Comparisons of their protein sequences as deduced from DNA sequences reveal a 45.2% identity. Both proteins contain two potential nucleotide binding sites.

The binding of NSF to Golgi membranes requires another soluble protein (SNAP) and a membrane receptor. This process appears to be stoichiometrical for these three components (Weidmann et al., 1990). *SEC17* appears to code for a yeast SNAP analogue. Cytosol from *sec17* mutants were inactive in the in vitro transport system, but can be complemented to function by addition of bovine α -SNAP (Clary et al., 1990). Genetic evidence confirmed a close interaction of the *SEC17* and *SEC18* gene products (Kaiser and Schekman, 1990).

A vertebrate protein called VCP (valosine-containing protein) has recently been described. It was first detected in different porcine tissues by specific antibodies. Its gene was cloned and sequenced by Koller and Brownstein in 1987. Peters et al. (1990) detected its *Xenopus laevis* equivalent which has a 96% sequence identity to porcine VCP as deduced from a partial DNA sequence. It has been characterized as a homooligomeric protein of 14–15S with NEM-inhibitable ATPase activity. A considerable degree of se-

1. *Abbreviations used in this paper:* NSF, *N*-ethylmaleimide-sensitive fusion protein; VCP, valosine-containing protein.

quence identity to Sec18p and NSF was reported. In contrast to Sec18p and NSF, the *X. laevis* VCP does not seem to be associated with vesicles and remains mainly in the supernatant when centrifuged at 100,000 g. Cell fractionation and immunofluorescence studies show VCP to be localized in both nucleus and cytoplasm.

The yeast cell division cycle gene *CDC48* has been characterized by a cold sensitive (cs) conditional mutant (*cdc48-1*) and four temperature sensitive pseudorevertants (Moir and Botstein, 1982; Moir et al., 1982). At the restrictive temperature, the *cdc48-1* mutant arrests as large budded cells with the nucleus located in the neck between the mother- and daughter cells.

We report the isolation and sequencing of *CDC48* and show that it belongs to the same multigene family as *SEC18* and the NSF and VCP genes. It appears to be the yeast homologue of the VCP gene. The *CDC48* gene product, designated CDC48p, and an immunologically related mammalian protein were localized by cell fractionation. The structural and evolutionary relationship of the members of this multigene family which includes *PAS1*, a member which is essential for the assembly of yeast peroxisomes (Erdmann et al., 1991), and TBP-1, a human protein that suppresses the *tat*-induced gene expression of human immunodeficiency virus (HIV; Nelbock et al., 1990) is discussed.

Materials and Methods

Materials

All enzymes and fine chemicals used for molecular biology were obtained from Boehringer GmbH (Mannheim, FRG). The pUC sequencing kit, and the DIG DNA labeling and detection kit from Boehringer were used for DNA sequencing and Southern hybridization, respectively. Tunicamycin was from Sigma Chemical Co. (St. Louis, MO). Marker proteins for gel filtration were bovine thyroglobulin and horse spleen apoferritin from Sigma Chemical Co., and bovine catalase, yeast alcohol dehydrogenase, and horse cytochrome *c* from Boehringer GmbH. For SDS electrophoresis, marker kit 30,000–200,000 and prestained kit 27,000–180,000 from Sigma Chemical Co. were used. Molecular weights were calculated by using the marker kit proteins as the only molecular weight standards. Bacto-Tryptone and yeast extract were from Difco Laboratories (Detroit, MI), and the buffer components from Merck (Darmstadt, FRG). All chromatographic media were obtained from Pharmacia Fine Chemicals (Freiburg, FRG), except for Celite 535 (Serva, Heidelberg, FRG), and hydroxyapatite, which was prepared as described by Bernardi (1971).

Rat livers were isolated from male white Sprague-Dawley rats of 200–300 g weight and perfused as described by Gebhardt and Jung (1982). Fresh porcine livers were obtained from the local slaughterhouse (Tübingen, FRG).

Strains, Plasmids, Genetic and Molecular Biological Methods

The haploid yeast mutant DBY2030 (*MATa ade2-101 lys2-801 ura3-52 cdc48-1*) was used for cloning and immunological investigation. Strain DBY877 (*MATohis4-619*) was used as a wild type for immunological investigation, cell fractionation, and protein purification. Gene disruption was performed in strain DBY5460 (*MATa/MAToade2-101/ADE2 lys2-801/lys2-801 leu2-3,112/LEU2 trp1Δ/TRP1 ura3-52/ura3-52 cdc48-1/CDC48*).

Yeast media and genetic manipulations were as described by Sherman et al. (1974). Cold sensitive mutants were arrested by incubation at 14°C for 14 h. For expression studies of the *GAL10* promoter, cells were grown on 0.66% yeast nitrogen base (Difco Laboratories) supplemented with 20 mg histidine/liter containing 4% galactose or 4% lactate as the carbon source for 20 h. For inhibition of N-glycosylation, 190 ng/ml tunicamycin was added to yeast cultures growing exponentially on YEPD, and the cells harvested after 3.5 h.

Plasmid YEp52 is described by Broach et al. (1983). Construction and

application of transposon mini-Tn10-LUK has been described (Huisman et al., 1987). Expression experiments with the T7 polymerase/promoter systems were performed with vector pT7-6 as described by Tabor and Richardson (1985).

For the construction of fusions with the *E. coli trpE* gene, different fragments from the essential region of *CDC48* were cloned as EcoRI-XbaI, EcoRV-XbaI, EcoRI-HindIII, and EcoRV-HindIII fragments into different pATH vectors (Dieckmann and Tzagoloff, 1985). Gene fusions in the correct reading frame were identified by their accumulation of insoluble protein detected on SDS PAGE gels. *CDC48/trpE* fusion proteins were prepared for immunization as described by Haarer and Pringle (1987), purified by SDS PAGE, detected by incubation of the gels with 0.25 M KCl, and electroeluted.

The lithium acetate procedure (Ito et al., 1983) was applied for yeast transformation using sonicated chicken blood DNA as a carrier. For the cloning of the *CDC48* gene, strain DBY2030 was transformed with 20 μg of the yeast genomic library constructed in vector YCp50 by Rose et al. (1987). Transformants were selected on minimal plates lacking uracil at 30°C, replica plated and incubated at 16°C. For DNA hybridization (Southern, 1975), the DIG DNA labeling and detection kit from Boehringer was used as described by the manufacturer. A 0.66 kbp EcoRI fragment that contains the promoter region and 510 bp of the ORF of *CDC48* was used as a probe against isolated total yeast DNA digested with EcoRI, HindIII, Sall, or XbaI, and against whole yeast chromosomes separated by orthogonal field gel electrophoresis (OFAGE) as described by Carle and Olson (1985). For gene disruption, the 1,170-bp ClaI fragment containing the first 940 bp of the *CDC48* ORF was replaced by a *URA3* gene on a HindIII fragment after filling in all ends with the Klenow fragment of DNA-polymerase I. 10 μg of the HindIII fragment containing the disrupted *CDC48* gene (corresponding to fragment C in Fig. 2) were transformed into strain DBY5460 and uracil auxotrophs selected. Alternately, 10 μg of a BglII fragment covering the upstream part of *CDC48* and containing a mini-Tn10-LUK insertion 200 bp upstream of the EcoRI-site inside the *CDC48* ORF were used for gene disruption. For confirmation of the disruption, total yeast DNA was digested with PstI and hybridized with a 1,040-bp EcoRI-HindIII fragment adjacent to the HindIII-fragment containing *CDC48*. The *CDC48* ORF-cassette was constructed as a HindIII fragment by cutting and filling in a HindIII site 40 bp upstream of the *CDC48* start codon. 8-bp HindIII linkers were ligated to this site and a DraI site 26 bp downstream from *CDC48*. Both ends of the construct were confirmed by DNA sequencing. For expression in yeast, the cassette was ligated into YEp52 and transformed into a diploid yeast carrying a *CDC48* gene disrupted with *URA3*. After sporulation, segregants were grown on YEP containing 4% galactose.

For DNA sequencing, restriction fragments of the *CDC48* genomic region were subcloned in pUC18 and pUC19. Sequencing was conducted essentially as described by Sanger et al. (1977) using the pUC sequencing kit from Boehringer. All parts were sequenced at least three times from different clones, 85% on both strands.

Related sequences were searched for in the Dayhoff database using the FASTP algorithm of Lipman and Pearson (1985).

Immunological and Electrophoretical Techniques

Immunization of rabbits and preparation of sera were performed as described in Fröhlich et al. (1989) using 200 μg of purified fusion protein for each injection.

Western hybridization and ELISA were performed as described (Fröhlich et al., 1989). Anti-CDC48p antisera were diluted 1:625–1:1,250 for Western hybridization and 1:250–1:500 for ELISA. A preliminary survey of filters stained by Western hybridization was conducted by using prestained molecular weight markers. For the calculation of molecular weights, unstained markers were applied to SDS-PAGE and stained with India ink (Hancock and Tsang, 1983) after their transfer to nitrocellulose. For immunofluorescence, cells were treated as described by Kilmartin and Adams (1984) with modifications. After application to polylysine coated slides, the samples were air dried instead of being treated with methanol/acetone. To visualize the microtubules, antibody YOLI/34 (Kilmartin et al., 1982), diluted 1:250, and affinity-purified FITC anti-rat IgG 1:100 were applied. DNA was stained by a 1-min treatment with 1 μg diaminophenylindole/ml.

The Laemmli system (1970) with a 6% acrylamide separation gel was used for SDS PAGE. Gels were stained with silver (Oakley et al., 1980) for detection of total protein.

Cell Fractionation

Yeast cells were fractionated according to the protocol of Gasser (1983). In

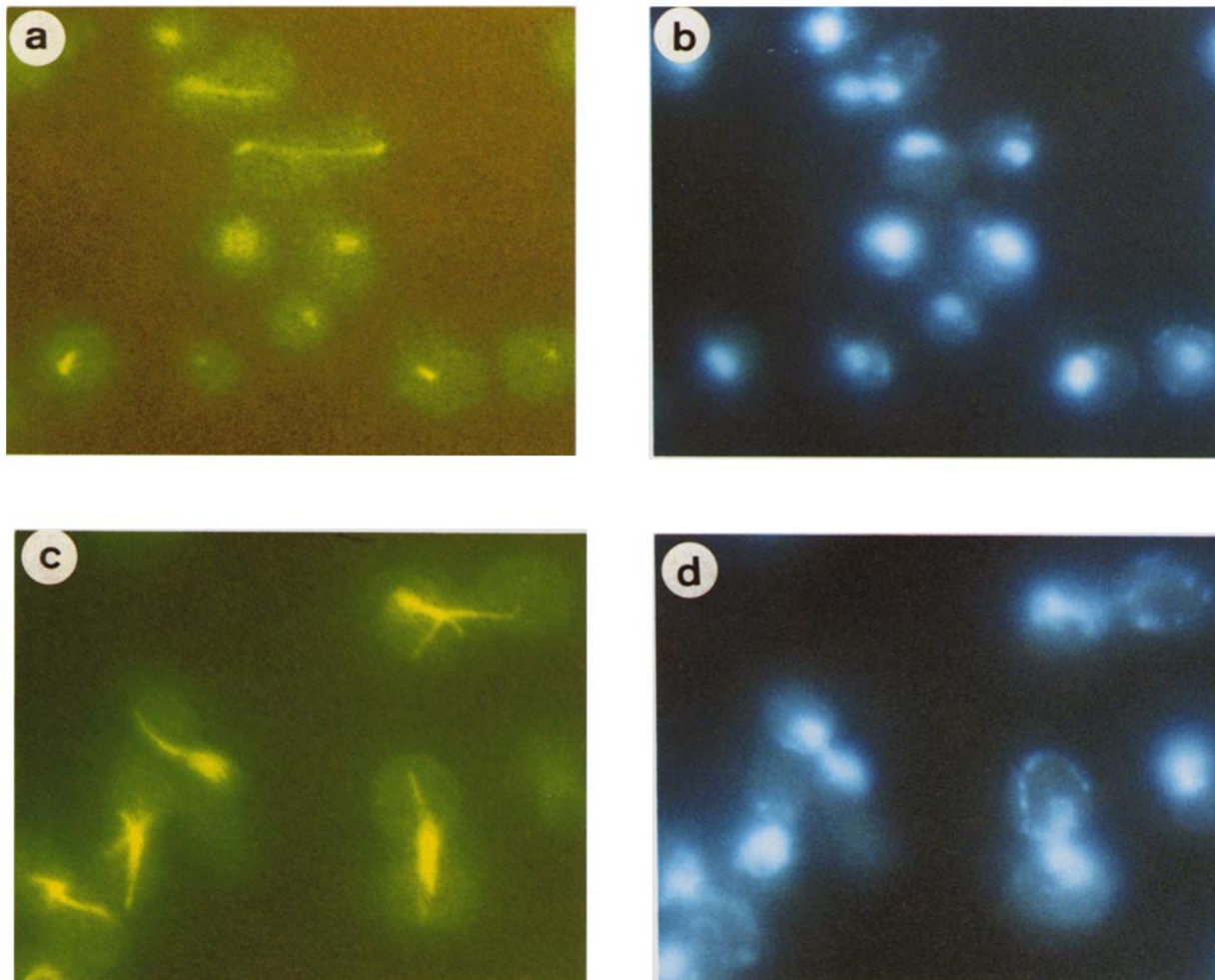

Figure 1. Indirect immunofluorescence with anti-tubulin mAb YOL1/34 (*a* and *c*) and DAPI fluorescence (*b* and *d*) of yeast wild-type cells (*a* and *b*) and *cdc48-1* mutants arrested at 14°C for 14 h (*c* and *d*).

some cases (mentioned specifically), protoplasts were shaken with an equal volume of glass beads on a Vortex laboratory shaker (Scientific Industries, Inc., Bohemia, NY) for 20 s after homogenization with a Dounce homogenizer. The postmitochondrial supernatant was centrifuged at 49,000 *g* for 30 min (49 K pellet), the (49K) supernatant was centrifuged at 177,000 *g* for 90 min (177K pellet), the resulting (177K) supernatant was referred to as cytoplasm. The procedure of Ide and Saunders (1981) was used for the isolation of yeast nuclei.

Contamination was calculated as the ratio of the specific concentration (correlated to protein) of a marker molecule in a contaminated fraction to that of the fraction where it is expected to be found. 98% of the alcohol dehydrogenase (Bergmeyer, 1974) was found in the cytosol and 1% in the mitochondria. 97% of the DNA (determined by microfluorometry [Cesarone et al., 1979]) were found in the nuclei and 3% in the mitochondria. The contamination of the 49K and 177K pellets with both markers was <2%. Glass bead treatment did not alter these values markedly.

Rat livers were fractionated as described by Fleischer and Kervina (1974), with the exception that the livers were perfused before cell disruption (Gebhardt and Jung, 1982). The following marker molecules were used: lactate dehydrogenase for cytosol (Bergmeyer, 1974), DNA for nuclei, succinate dehydrogenase for mitochondria (determined by reaction with 2-(*p*-iodophenyl)-3-*p*-nitrophenyl-5-phenyltetrazolium chloride; Pennington, 1961), and NADPH-cytochrome P-450 reductase for ER (Strobel and Dignam, 1978). Contamination of other fractions was <5% for lactate dehydrogenase, <7% for DNA, 12% for succinate dehydrogenase (in smooth ER), and <5% for P-450 reductase with a sevenfold higher specific activity of the enzyme in smooth than in rough ER. The fractions of "heavy" and "light" microsomes both showed <3% contamination with lactate dehydrogenase and succinate dehydrogenase, <5% of DNA, and 60% and 20%, respectively, of the P-450 reductase level of the smooth ER.

Protein Purification

Protein was determined with the Bradford assay (Bradford, 1976). Isolation buffer H consisted of 20 mM triethanolamine/hydrochloride pH 7.5, 1 mM EDTA, and 2 mM DTT.

Approximately 300 g of porcine liver were disrupted in buffer H containing 250 mM sucrose by homogenization with a 100 ml Potter-Elvehjem type tissue grinder. The homogenate was filtered through a cotton cloth and centrifuged at 1,000 *g* for 15 min. The resulting supernatant was centrifuged at 12,000 *g* for 15 min and 100,000 *g* for 60 min. 1 g Celite was added per 100 mg protein, and the suspension was stirred for 30 min. Ammonium sulfate was then added to 40% saturation. The resulting slurry was packed into a column (6-cm-diam) and eluted with a 600-ml linear gradient of 40 to 0% ammonium sulfate in buffer H. Fractions containing CDC48 cross-reacting protein were pooled, dialyzed against buffer H, and applied to a DEAE Sephacel column (3 × 6 cm). The protein was eluted with a 600-ml gradient of 0–500 mM NaCl in buffer H. Pooled fractions were dialyzed against 10 mM potassium phosphate buffer pH 7.5 containing 3 mM mercaptoethanol and applied to a hydroxyapatite column (2 × 15 cm). The column was washed with an 80-ml pulse of 500 mM NaCl in phosphate buffer and eluted with a 10–250 mM potassium phosphate gradient. After dialysis against buffer H, the protein was concentrated fivefold by binding to and pulse elution from a 5-ml DEAE Sephacel column. The concentrated protein was applied to a 2 × 100 cm Sephacryl S 300 gel filtration column. For purposes of molecular weight determination with this column, 1 mg each of thyroglobulin, apoferritin, catalase, alcohol dehydrogenase, and cytochrome *c* was added per ml of the isolated protein. Yeast CDC48p was purified from 150 g of yeast strain DBY877 grown exponentially on YEPD using a modified version of the procedure described above. The modification consists of using 20 mM Tris/HCl pH7.5 containing 1 mM EDTA and

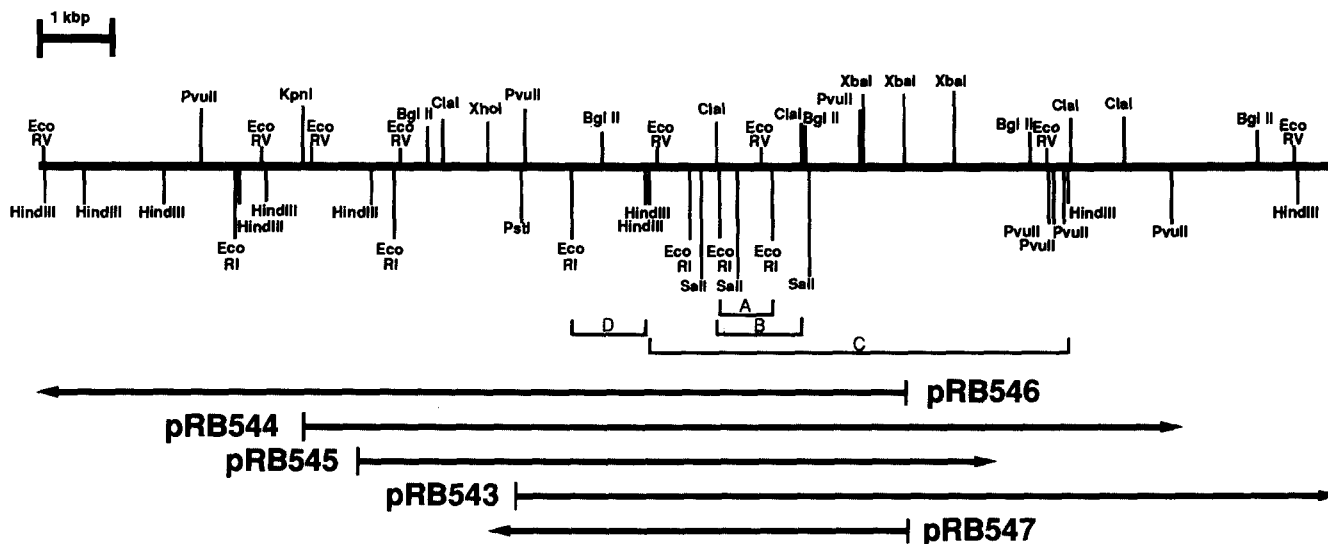

Figure 2. Restriction map of the *CDC48* genomic region. Arrows mark range and orientation of the cloned inserts, pointing clockwise in YCp50. Fragments used as hybridization probes (A and D), or in gene disruptions (B and C) are marked with brackets.

2 mM mercaptoethanol instead of buffer H. The yeast cells were disrupted by mixing with an equal volume of glass beads in a Waring blender for 60 s. The supernatant was then centrifuged at 22,000 g for 15 min. After elution of the protein from the hydroxyapatite column, ammonium sulfate was added to 30% saturation. The resulting solution was applied to a phenyl sepharose column (2 × 10 cm), and eluted with a 300-ml gradient 30% ammonium sulfate/0% ethylene glycol to 0% ammonium sulfate/50% ethylene glycol in Tris buffer. The pooled fractions were concentrated and purified by gel chromatography as described above.

Results

Histological Investigation of the *cdc48* Mutant

cdc48-1 mutants were cell cycle arrested at 14°C for 14 h and stained with DAPI and fluorescein-labeled anti-tubulin antibody. In most cells, bundles of microtubules were detected protruding from an unseparated spindle pole body and spreading aberrantly throughout the cell. As a control, wild-type cells in the stage of nuclear division showed one short mitotic spindle inside the nucleus connecting separated spindle pole bodies (Fig. 1).

Isolation and Characterization of the *CDC48* Gene

The *CDC48* gene was cloned from a yeast genomic library based on the vector YCp50 (Rose et al., 1987) by complementation of the mutant cold sensitive phenotype. Seven clones gave plasmids with four different inserts (pRB543 to pRB546), all of which overlapped in a region of 5.8-kbp length (Fig. 2). This region was subcloned by cutting plasmid pRB546 with *Xho*I and religation. The resulting construct pRB547 was of YRp type lacking the YCp50 CEN region and the *URA3* gene.

Mini-Tn10-LUK mutagenesis was applied for a more precise localization of the *CDC48* gene on pRB547. The results have been published previously (Huisman et al., 1987). The range essential for gene function was mapped to a region of 2470 to 2590 bp in size. Evaluation of the Mini-Tn10 coded β -galactosidase activity determined the direction of transcription and indicated that gene expression should be very low.

Southern hybridization using an *Eco*RI 0.66-kbp fragment (Fig. 2, fragment A) localized at the beginning of the essen-

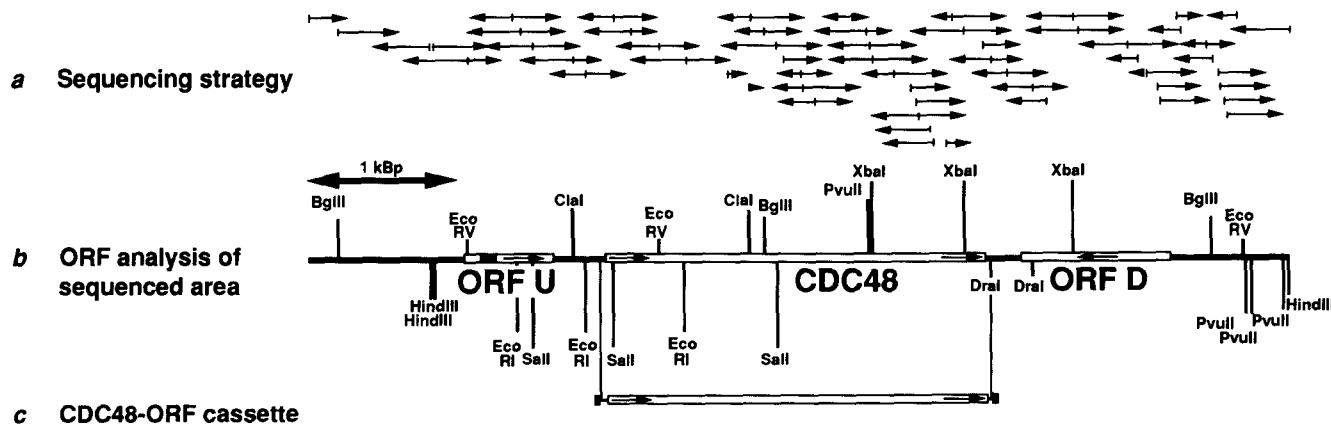

Figure 3. (a) Sequencing strategy, (b) restriction map and potential open reading frames (ORF Upstream of *CDC48*, *CDC48*, ORF Downstream from *CDC48*) of the sequenced genomic fragment, and (c) subcloned *CDC48* ORF-cassette.

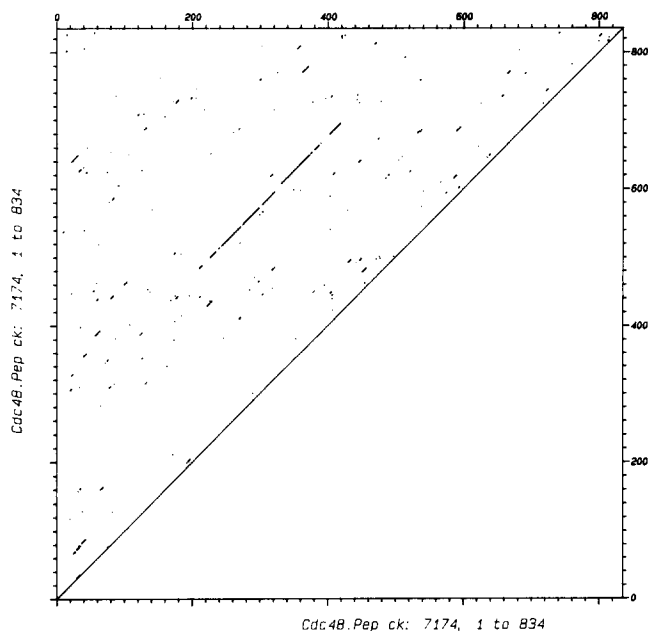

Figure 5. Self homology plot of the CDC48 protein showing the internal duplication. Dots mark identity of at least 8 amino acids in a stretch of 11.

tial region of *CDC48* as a probe showed that the gene is present in one copy per haploid genome. Hybridization of yeast chromosomes separated by orthogonal field agarose gel electrophoresis (OFAGE; Carle and Olson, 1984, 1985; Schwartz and Cantor, 1984) mapped the gene to chromosome IV (data not shown).

The chromosomal copy of the *CDC48* gene was disrupted (Rothstein, 1983; Shortle et al., 1982) by integration of transposon *Tn10*-LUK or by replacement of an internal *Cla*I-fragment (Fig. 2, fragment *B*) with *URA3*. A fragment bearing *CDC48::Tn10*-LUK or *CDC48::URA3*, respectively, was transformed into diploid strain DBY5460, heterozygous for the cold sensitive *cdc48-1* mutation, and replaced a chromosomal copy via homologous recombination. In both constructs, ~50% of the *Ura*⁺ transformants had acquired a cold-sensitive phenotype, indicating a disruption of the *CDC48* wild-type allele. The DNA was digested with *Pst*I and hybridized with an *Eco*RI-HindIII fragment (Fig. 2, fragment *D*) adjacent to, but not overlapping with the fragment used for the gene disruption. In both the cold sensitive and the non-cold-sensitive disruptant, the same additional band of expected size (2.8 kbp) was labeled as compared with wild-type cells. This shows that the cloned gene is indeed *CDC48* and not an extragenic suppressor of *cdc48-1*. All viable spores of the disruptants were *Ura*⁻ and displayed the same temperature dependency of growth as their diploid progenitor. The spores carrying the disruption only proceeded

through one, in some cases two, cell cycles, arresting as tiny cells with single buds of equal size as the mother cells. This proves the essential role of *CDC48* and rules out effects due to the mutant allele.

DNA Sequence Analysis

A region of 6,485 bp enclosing the *CDC48* gene was sequenced from double stranded DNA using the chain termination method of Sanger et al. (1977; Fig. 3 *a*; Fig. 4). A large region was sequenced to prevent the oversight of a potential upstream regulating sequence (Guarente, 1984) or other cell cycle genes in proximity, as described for *CDC9* and *CDC36* (Barker et al., 1985). An open reading frame of 2,505 bases was detected (Fig. 3 *b*) coding for a protein of 834 amino acids and with a molecular weight of 91,713. The coding region corresponds exactly in size and position to the region essential for *CDC48* function as determined by *Tn10*-mutagenesis.

The promoter region contains the typical consensus elements (Dobson et al., 1982), though with inconsistencies (GGCAACCC at -164 instead of GGPYCAATCT, ATATAT at -125 and TATTTAA at -109 instead of TATAT/AAT/A), implying weak gene expression. A potential gene containing an intron consensus sequence (Cellini et al., 1986; Langford et al., 1984) is located only 354 bp upstream of *CDC48*, restricting the area for *CDC48* upstream regulatory sequences. A *Tn10* insertion located 30-50 bp upstream of the *CDC48* start codon did not abolish the ability of plasmid pRB547 to complement the *cdc48-1* phenotype.

The *CDC48* terminator showed the consensus sequences TAAAATAAG 188 bp downstream from the stop codon (Bennetzen and Hall, 1982*b*), and a T-rich region downstream from the stop codon (48 of 102 residues) followed by TAG (143 bp downstream), TATGT (183 bp downstream), an A-rich region (12 of 14 residues), and TTT (233 bp downstream from the stop codon; Zaret and Sherman, 1982). An open reading frame downstream from and oriented inversely to *CDC48* seems to use the same region for its termination. The reasonably high codon bias index (a measure for the bias toward codons homologous to the major yeast isoacceptor tRNA species and an indicator for the expression level of the gene, Bennetzen and Hall, 1982*a*) of both open reading frames bordering *CDC48* (0.31 for the spliced ORF, 0.13 for the ORF downstream from *CDC48*) make them likely candidates for functional genes. A database search did not reveal significant similarity of either of these two to known genes.

Analysis of the *CDC48* protein revealed no potential membrane spanning hydrophobic stretches or signal sequences for an import to the ER. Two perfect consensus sequences for nucleotide binding (Fry et al., 1986; Gorbalenya and Koonin, 1989; Möller and Amons, 1985) were found, part of an internal duplication of ~200 amino acids (Fig. 5; Fig. 6 *b*).

Figure 6. Protein sequence alignment of CDC48p, VCP, Sec18p, NSF, TBP-1, and Pas1p. TBP-1 has been aligned to both copies of the region of similarity (*A* and *B*). The nucleotide binding motifs (Gorbalenya and Koonin, 1989) are marked with a bracket. (*a*) Overview: The degree of identity is displayed using a grayscale. The portion of amino acid residues identical to CDC48p is calculated, starting at the amino terminus, within overlapping segments of 20 residues displaced from each other by one residue. Values <20% identity are displayed by white, values >80% by black. Between these thresholds, gray values equivalent to values of identity are displayed. (*b*) Detailed alignment: amino acids identical to CDC48p are boxed.

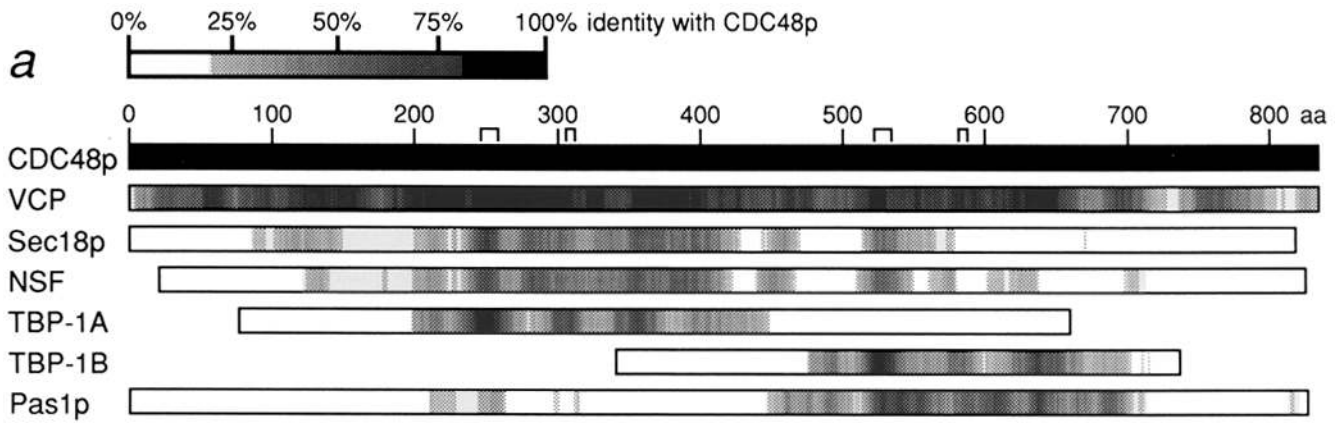

b

Pas1p MTTTKRLKPFENLRIQFSNAIVGNFLRLPHSIIINVLESTNYAIQEFGI AVHSHNSDIP I VHLGWGDHDSGSSENVV

Pas1p LINPVLATVYDLNQLKSPVLDVLIQRYDHTHLATEVYVTPETSDDEWEI IDANAMRFQNGEILHQTRIVTPGETLICYLEGIVTKFKIDRVEPSMK SARITD

CDC48p M GEEHKPLLDASVSTCEERLATAIIRRRKKKMLLVLDLAINDDNSV IAINSNIMKLELFRGDTVLVKQKKRDTVILVLDLDELHGDACHIRNVRVRRN
VCP M ASGADSKGDLSTAILKQKRRPRLIVDEAINDDNSV VLSLQPFMDELQFRGDTVLVKQKKREAVLIVLSDITCDEKIRNVRVRRN
Sec18p M FKIPFGKAAANHPDDMTNMDTRTRHIVSNCPNNSYALANVAAVSPDFF NNIYIII DNLVPTTRHSNDIPIPTIGFVGNQRTW
NSF SEPDVSAKMA GRSMQAARCPIDELISLNCVAVSEKDYQ SQHIVIVRTSPNHKYITLRLTHPSVVHGSVAFSLPQRKW
TBP-1A MSTEEIIQTRLLDSEIKIMKSEVL
TBP-1B
Pas1p GSLVVVAPKVNKTRLVKAEYGHSNKTIIRNGAIGLTKKVLIRSTVCKMDFPKDNLFPVVIISDGAQLPSQKGYASIVKCSLRQSKKSDSDNKSVGIPSKKI

CDC48p LRIRLGLIIVTHFCPIIKYATRISVI PIADTIE GITGNLFDV FLKPYHVEAYRFR KGDHF VVRGGMHVEFKVVDVEFSE
VCP LRVHLGLVISTFCPIIKYGRIRIPIIADTIE GITGNLFDV FLKPYHVEAYRFR KGDHF VVRGGMHVEFKVVDVEFSE
Sec18p GGSLNGLVQAKAFDLHKYSKCSLIGSDIIDISFRARGKAVSTVPIQDELAKCFVRCMESQIFSEIYQLIMEFQGHFEDLKRIRNVQAI DLGDI EPTS
NSF AGLSTQAEIV ALYSFDKAKQCIGTMTIEMDFLQKKNIDSPYTDQDMAAEEIQCFNNGFVSGQQLVSPNDKLEGLLVKDIEMDPSILKGFAS
TBP-1A RVTHELQAMKD KIKENSEKIVNKTLPYLVSNVIELLDVDPNDQEDGANIDDSQRKGC AVIK TSTRQTYFLPVIIGLIDAEKL RFGD
TBP-1B
Pas1p GVFIKQISQIPENHIALSSHLDWAFPTHMNGAKIKLEFLQMNQANIISGRNATVNIKISGKDVPTKSGDQYSKLLGGTLLTNLILPTQIIIEIKKGE

CDC48p MAVV ACHIIITHVEGEPINREDEENNM EVGYDI IGGCRKQIAQI REMVELPLRHHQLFKAIGIKFPFRGLMYGPPGTG
VCP YCIV APLDTVIHCEGEPINREDEEESLN EVGYDI IGGCRKQIAQI REMVELPLRHHQLFKAIGIKFPFRGLMYGPPGTG
Sec18p AVATGIETKGILTQQTQINFPKGRGLVNLKSSNSIRPRNSAVIRPDKFKELVGLGDLMEFTTRHRRAFASRIFPHSVIEKLGISHVKGLIYGGPPGTG
NSF GKROKIEV GLVVGNSQVAFEKIENSLLNLGKAKTRNSRQSIINPDWPFKMGIGGLIDREFSIHRRAFASRVFHHIEVEGQMGCHRVKGLIYGGPPGTG
TBP-1A LVGVNKSYSYLLET LPTIYDSRVKAMVDE RPTECHSI IGLLKRQIQELVEAIVLBNKREKENLGIQPHFGVLMYGGPPGTG
TBP-1B
Pas1p SEQCLNLSNEISNESVQWKVVTQMGKEVKDIIIRHLPKHYHVKETGEVSRTSK DEDDFITVNSIKKERVNYLTSPIIATP AITLLRQGLG

CDC48p KTLIARAVANETGAFFFLINGPFRVMSRMAGESESNLRKAFEEAEKNAPA IIFIDEIDSIAPKE IKTNGE VERRVVSQLLTLMDCMR
VCP KTLIARAVANETGAFFFLINGPFRVMSRMAGESESNLRKAFEEAEKNAPA IIFIDEIDSIAPKE IKTNGE VERRVVSQLLTLMDCMR
Sec18p KTLIARIGTMLNAREPKIINQPEIISKYVGSSEANIRLILKDAEAERYAKGESSLHIIFIDEIDSIAPKE GSRDGTQVGDVNVQLLARMDVD
NSF KTLIARIGTMLNAREPKIINQPEIISKYVGSSEANIRLILKDAEAERYAKGESSLHIIFIDEIDSIAPKE GSRDGTQVGDVNVQLLARMDVD
TBP-1A KTLIARIGTMLNAREPKIINQPEIISKYVGSSEANIRLILKDAEAERYAKGESSLHIIFIDEIDSIAPKE GSRDGTQVGDVNVQLLARMDVD
TBP-1B
Pas1p KTRLLKELINEVEKDDHHIFVKYADCETLHETSNLDKTQRLIME WCSFCYWYGPSIIVLNVLEALFQEP QANIDPSPNNGQWDNASKILNFFPIN

CDC48p RRSNVVVAATNRPNSIDPALRRFRGFRDREVDIGIPDATORLEMLIHTKNMR LADDVDLELAAETHQVVGADTSLCSEAAAGCI RRRKMDLII
VCP RRAHVIVVAATNRPNSIDPALRRFRGFRDREVDIGIPDATORLEMLIHTKNMR LADDVDLELAAETHQVVGADTSLCSEAAAGCI RRRKMDLII
Sec18p QLNIIIVGNTNRKDIIDSAIIRGRHEVQVIEIHPDEGRICQIPDITKRMRENMMGDDVNLAEALVTKNFGAEIEGLVKSNSFPAT NKTVN LG
NSF QLNIIIVGNTNRKDIIDSAIIRGRHEVQVIEIHPDEGRICQIPDITKRMRENMMGDDVNLAEALVTKNFGAEIEGLVKSNSFPAT NKTVN LG
TBP-1A PNTQVRYAATNRPNSIDPALRRFRGFRDREVDIGIPDATORLEMLIHTKNMR LADDVDLELAAETHQVVGADTSLCSEAAAGCI RRRKMDLII
TBP-1B
Pas1p QVTKIPNK DNKE IIVLFSGKQKTCINPLLPDKHFVSETNSLRAPDKHARAKLLEYFFSKNQIMKLNRLDQFSIISLITGEGFSP LDLEIFTE

CDC48p LDEDEIDAELVLSIGVTMDNFRFALGNSNPSALRET VVESVNTVDDVGLLEIKKEELNETVEYVPLHPDQYTKFGLSPSKGVLFYGGPPGTGKTL LAKA
VCP LDEDEIDAELVLSIGVTMDNFRFALGNSNPSALRET VVESVNTVDDVGLLEIKKEELNETVEYVPLHPDQYTKFGLSPSKGVLFYGGPPGTGKTL LAKA
Sec18p KGATKLNKTDIARLVTRDEHLNAILNDVTHAF GISEEDLKTCEGGMLYSERVNSILKNGARYVVRVRESDEKRLVSLIITGPAQSGKTLALAE
NSF STKVEVDEKAEKSLQVTRGDLASLENDIKHAF GTNQEDYASYIMNGIKWGDPPVTRVLDDGEILVQCFKNSDRITLVSVLLESPHSGKTLALAK
TBP-1A EYVMEGILEVQAKKANLQYYA*
TBP-1B DAEKLPKPDLVGVNKSYSYLLETLPTEYDSRVKAME MRPTEQYSIIGGLDKQIQETVEAIVLBNKREKENLGIQPHFGVLMYGGPPGTGKTL LAKA
Pas1p KIFYDLQIRDCDNVITREIISKISGSAFTPSALRGVVKLTRETNIKMLITGLANADVILLETLEMTKTYEPIFVNCPRRLRSGLIYVGPCKOKTL LASA

CDC48p VAVESVANFISVKGPE LLSMVFGESESNIRDFDKARAAAPVVEIDELDSIAKARGGSGDAGGASDRVNVQLLTEMGDNAR KNVFIIGATNRPDQ
VCP VAVESVANFISVKGPE LLSMVFGESESNIRDFDKARAAAPVVEIDELDSIAKARGGSGDAGGASDRVNVQLLTEMGDNAR KNVFIIGATNRPDQ
Sec18p INLKSQFPIIRLISNLESGSESARIAVDNTHIRDAYKSPNLVLLVLSLETLV DWVPIGRPFNSNLLQKVALKRRFPQDRLLIMTISAYSV
NSF INESNPFPIIKICSDPKMIGFSETARQAKMIFIDAYKSQLSCVVDIERTLL DVVPIGRPFNSNLLQKVALKRRFPQDRLLIMTISAYSV
TBP-1B QNACTKATLKLKLAGHQIVQVPIIGDGAKLVRDPAALAKEKASIIIDELDLAGTKRPFSEKAGDREVQITMLELNLQDQFQPN TQVNYIATNRPDQ
TBP-1B
Pas1p VAVQCCGNFISVKGPE IINKFISGSENIREFERRASVRCIILFDEPDSIAPRQGH DSTGVVDRVNVQLLTEMGDAEGLD QVYTLAATSRPPL

CDC48p IDPAILRPGRLDQLIYVPLPDEARLSIINA QLRRIPLFGLSITATARATGFSGADLLYVORARVAT RLSIEAHRCHAEEREVKME
VCP IDPAILRPGRLDQLIYVPLPDEARLSIINA NLRKSPVAKVDVLEFPAKMNDFSGADLFEICQACAKLAI RESISEIRREPERQTNPS
Sec18p LQ QMDILSCFDN EIAVPMNLDLNNVMIESNFLDAGRVKVINELSRSCP NFNVGIK RLTNI
NSF LQ MEMLNAFST TIHVPNIATGECILLEALELGNFKDKERTIIPQVKGK VAVTGIK KLLMLI
TBP-1B IDPAILRPGRLDQLIYVPLPDEARLSIINA HSRNMYSPVNYEELARQDDFNGAQCACVCEPAGMIALARGATLTHEDYMGILELQ
TBP-1B
Pas1p ILSNILLRPGRLDKSVICNIPTEBRDITLQAVVNSKDKDTGQRFALFNALNLIKLAETAGFSGADLQGLCYNAYLKS VHRWLSAALGSEVVPNDNI

CDC48p GEIVEMDEGKAEQEPEMDPVPIITKEHFAEAMKTKARVSDLAELRRYBAYSQOMASRQFESNFPENDAPLITTTATINANSNNSAPSGAGAAFGSNAE
VCP AMEVE EDDVPEIRRIHFEAEAMRPARRSVSNIDIRYEMFACLQCSRQ FGSFRFPSPGNQGGAGP SOGSGGQGSVYTE D
Sec18p ETA RHDE DPNVELVEIET YRVRLALALLR EEGASPLDFD*
NSF EMSLQDFE
TBP-1B AKKANLQYYA*
Pas1p EYFSINEHGRREENRLRLKTLQDQVHVHETKTSTSAASELTAVVRINDLLEACQETKPSISTSELVKLRGIYDRFQDRNGEMPNGENSIDIGSRISLIM*

CDC48p EDDLYS*
VCP NDDLYS*

A computer search of sequence databases yielded three proteins with a high degree of identity to CDC48p, namely VCP from pig (Koller and Brownstein, 1987), Sec18 protein from yeast (Eakle et al., 1988), and NSF (Beckers et al., 1989; Diaz et al., 1989) from chinese hamster. All of which proteins share the internal duplication and the two nucleotide binding domains. Three other related proteins, the *Xenopus laevis* analogue of VCP (Peters et al., 1990) PasI protein from yeast (Erdmann et al., 1991), and human TBP-1 (Nelbock et al., 1990), have been described recently.

VCP from pig shows a 69.5% identity to the CDC48p over the whole length of the protein (Fig. 6). VCP is a protein of 806 amino acids with a molecular weight of 88,660 and found in every tissue yet examined (e.g., adrenal cortex and medulla, ileum, cerebellum, heart, liver). The *Xenopus laevis* analogue of VCP has been detected in the cytoplasm and in the nucleus of eggs as a homooligomer of about six subunits with a sedimentation constant of 14–15S (Peters et al., 1990).

The region of identity of Sec18p and NSF to the CDC48 protein covers the internal duplication containing the two potential nucleotide binding sites (degree of identity 33.8% for CDC48p/Sec18p and 34.5% for CDC48p/NSF in a range of 373 and 372 amino acids, respectively). Identity is most pronounced in the first repeat (46.6% identity for CDC48p/Sec18p and 47.7% for CDC48p/NSF in a range of 178 and 176 amino acids, respectively). The amino- and carboxy-terminal regions show no obvious similarities (Fig. 6).

PAS1 is a yeast gene required for peroxisome assembly. The predicted protein sequence also contains the duplication and the nucleotide binding domain, though with a lower degree of conservation for the first and a higher for the second repeat. The identity is 52.3% of 109 amino acids compared to CDC48p in the region carboxy-terminal from the second nucleotide binding domain (amino acids 798–913 of PasI, amino acids 588–696 of CDC48p), a region which shows very little homology between CDC48p and NSF/Sec18.

TBP-1 is a human protein localized mainly in the nucleus which interacts with the HIV *tat* gene product and suppresses its transactivating activity (Nelbock et al., 1990). TBP-1 contains only one copy of the region which is duplicated in the other related proteins. It has an identity of 42.7% in 239 amino acids to the first copy, and 37.3% in 252 amino acids to the second copy of the repeat in CDC48p. The region of homology extends to close to the carboxy terminus of TBP-1.

Immunological Investigations and Intracellular Localization of the CDC48 Gene Product

To obtain antisera against CDC48 protein, different fragments of the *CDC48* open reading frame were fused "in frame" with the *E. coli trpE* gene using the pATH vector system (Dieckmann and Tzagoloff, 1985) and expressed in *E. coli*. The different fusion proteins purified from SDS-PAGE gels were used to raise antisera in rabbits.

On immunoblots of yeast cell extracts, all antisera recognize a protein of an apparent molecular weight of approximately 115,000. The protein was present in exponentially growing and in stationary cells and appeared unchanged in *cdc48-1* mutants incubated at 14°C for 14 h.

The *CDC48* gene was subcloned with only 40 bases in front of and 26 bases after the presumed open reading frame

(*CDC48 ORF-cassette*; Fig. 3 c). The construct was cloned into yeast expression vector YEp52 (Broach et al., 1983), a high copy number plasmid carrying the highly inducible and glucose repressible *GAL10* promoter. The plasmid was transformed into a diploid strain carrying a *CDC48::URA3* disruption. After sporulation, haploid clones containing both the gene disruption and the plasmid could grow on minimal media containing 4% lactate or 4% galactose. No growth was observed with 4% glucose as the carbon source. The vector alone did not complement. Western hybridization shows that galactose grown cells contain higher levels of CDC48p than wild-type cells and lactate grown cells contain much lower levels. Thus, low levels of *CDC48* protein seem to suffice for its function, while a high level has no deleterious effect on the cell. This dependency of the immunological signal on media conditions proves that the protein detected with the antisera is indeed the *CDC48* gene product. In rat and porcine liver extracts, the antibodies strongly and specifically stained a protein with an apparent molecular weight of approximately 100,000.

Immunofluorescence staining of yeast and porcine cells with the antisera resulted in only a weak background staining. This could be due to a specificity of the antibodies for CDC48 protein denaturated by SDS treatment or boiling. It may be the reason why the antisera did not precipitate CDC48 protein from cell extracts.

The *CDC48* gene product appears to be much larger than expected from the DNA sequence data. Tunicamycin, an inhibitor of *N*-glycosylation, had no effect on the protein size. The *CDC48* ORF-cassette (Fig. 3 c) was expressed in *E. coli* using a bacteriophage T7-derived expression system (Tabor and Richardson, 1985). The protein detected by Western hybridization was indistinguishable in size to the yeast protein.

Yeast and rat liver cells were fractionated by differential sedimentation and sucrose density gradient centrifugation. The fractions were characterized by their contents of marker molecules and tested for reaction with anti-CDC48p antibodies by immunoblotting (Fig. 7, a and b).

In yeast spheroplasts lysed osmotically, CDC48p was found as a protein of 115 kD in a pellet obtained by centrifugation at 49,000 *g* for 30 min. The fraction of purified nuclei obtained by Ficoll gradient centrifugation shows a weak band of 104 kD in Western hybridization, which may correspond to a degradational fragment of CDC48p. The 177,000-*g* pellet and supernatant only contain traces of CDC48p. No CDC48p cross-reacting activity was found in the mitochondria.

If the spheroplasts are broken by shaking with glass beads for 20 s, most of the CDC48p is found in the 177,000-*g* supernatant, some in the 177,000-*g* pellet, and little in the 49,000-*g* pellet. The distribution of the compartment markers shows little change compared with osmotically lysed cells, indicating insignificant damage of the organelles.

In fractionated rat liver cells, no CDC48p cross-reacting activity is detected in the Golgi and plasma membrane fractions. Traces of a cross-reacting protein of 100 kD are found in the "light microsomal" fraction precipitated at 186,000 *g*, in the 186,000-*g* supernatant, and in isolated nuclei. Most of the 100-kD protein can be detected in the "heavy microsomes" prepared from a 51,000-*g* centrifugational pellet by sucrose gradient centrifugation. After combining the two microsomal fractions and their separation into smooth and

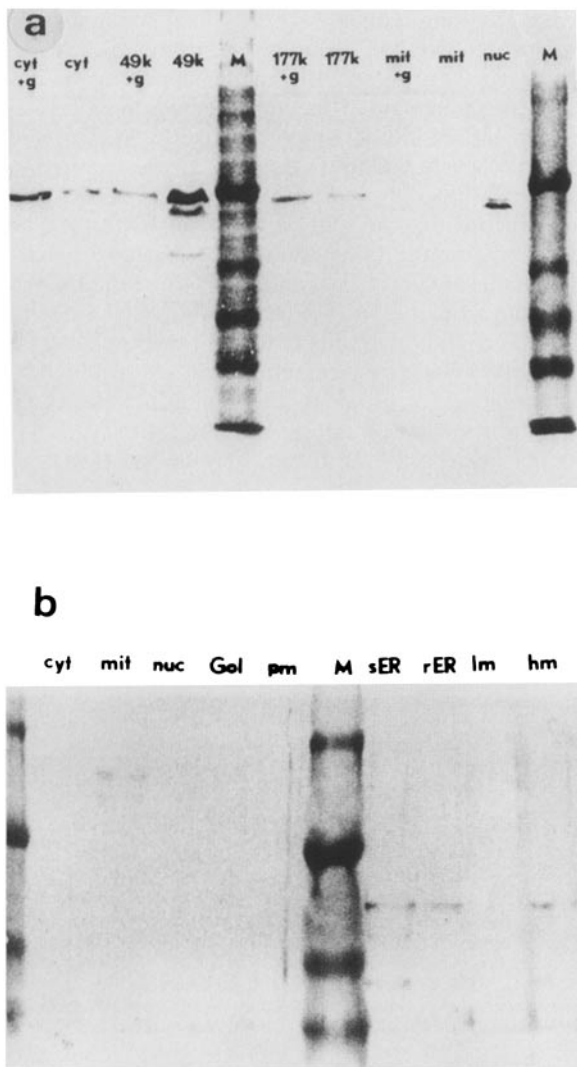

Figure 7. Immunostaining of intracellular fractions of yeast (a) and rat liver (b) cells by Western hybridization with anti-CDC48p antibodies after separation by SDS-PAGE. Yeast fractions: *cyt*, cytoplasm (22 μ g/17 μ g protein applied to gel); *49K*, 49,000 g pellet (23 μ g/19 μ g); *M*, prestained marker proteins; *177K*, 177,000 g pellet (53 μ g/28 μ g); *mit*, mitochondria (9 μ g/7 μ g); *nuc*, nuclei (22 μ g); the samples labeled +g (corresponding protein values before slash/) have been shaken with glass beads. Rat liver fractions: *cyt*, cytoplasm (165 μ g); *mit*, mitochondria (150 μ g); *nuc*, nuclei (130 μ g); *Gol*, Golgi vesicles (8 μ g); *pm*, plasma membrane (10 μ g); *M*, prestained marker proteins; *sER*, smooth endoplasmic reticulum (15 μ g); *rER*, rough endoplasmic reticulum (18 μ g); *lm*, light microsomes (40 μ g); *hm*, heavy microsomes (30 μ g).

rough endoplasmic reticulum, CDC48p is present in both fractions in similar concentration. In mitochondria, a cross-reacting protein of 164 kD was detected whose relation to the other cross-reacting proteins was not further investigated.

If the rat liver is frozen before cell fractionation, most of the 100-kD protein cross-reacting with anti-CDC48p is found in the 186,000-g supernatant.

CDC48p was purified from yeast and its homologue from porcine liver using several chromatographic steps. The column eluates were tested for CDC48p by ELISA, the

pooled fractions by immunoblotting. Several fractions, which showed a positive reaction in ELISA, did not contain CDC48p according to the Western hybridization. In the absence of components with free thiol groups in the media, the CDC48 protein tends to associate nonspecifically with other proteins, presumably by forming disulfide bonds. For the purification, 2 mM mercaptoethanol or DTT is added to all buffers.

Silver staining of the purified proteins following SDS PAGE showed no contaminating components. Gel filtration on Sephacryl S300 columns yields a molecular weight of 580–600 kD for the yeast CDC48p and 530–550 kDa for the corresponding rat protein.

Discussion

Mutations in the yeast cell division cycle gene, *CDC48*, lead to an arrest of cell division in the large budded state with an undivided nucleus and bundles of microtubules spreading throughout the cytoplasm and originating from an unseparated spindle pole body.

The chromosomal region containing the *CDC48* gene was cloned and the gene localized. Gene disruption proved its essential role; spores containing the disruption underwent one, at most two more cell divisions and showed no cell growth.

Sequencing the region of the *CDC48* gene revealed an open reading frame at the expected location. A database search with the amino acid sequence deduced from the DNA sequence revealed protein VCP from pig with a sequence identity of 69.5% over the full length of both proteins. We assume that CDC48p and VCP are functionally equivalent due to their high degree of homology.

Other relatives of CDC48p were found to be the secretory proteins Sec18p from yeast and NSF from chinese hamsters, and yeast Paslp, which is essential for peroxisome assembly. All of these proteins share a central region, which seems to have arisen by an internal sequence duplication, and which contains two nucleotide consensus sequences. The internal duplication is best conserved for CDC48p and VCP. TBP-1 appears to have separated from the other proteins before the duplication took place. It has, however, retained its high similarity.

Immunoblotting using an antibody against a fragment highly conserved between all of these proteins shows CDC48p to be far more abundant in the yeast cell than Sec18p or Paslp (Erdmann et al., 1991). This is in accord with the different codon bias indexes (calculated as in Benetzen and Hall, 1982a), an indicator for the level of gene expression: 0.41 for *CDC48*, 0.21 for *SEC18*, and 0.05 for *PAS1*. The degree of expression of *CDC48* necessary for cell proliferation appears to be low. As in *SEC18* (Eagle et al., 1988), the lack of any promoter consensus upstream of the ORF still allows complementation of a corresponding mutant phenotype.

Inhibition by NEM, a reagent which blocks free thiol groups, has been described for NSF, Sec18p, and VCP from *Xenopus laevis*. Unexpectedly, no cysteine residue common to all of the related proteins could be located by sequence alignment. Another major difference between the functional subgroups can be derived from the amino acid composition of the amino-terminal regions which are not conserved between the subgroups. While CDC48p and VCP have a high

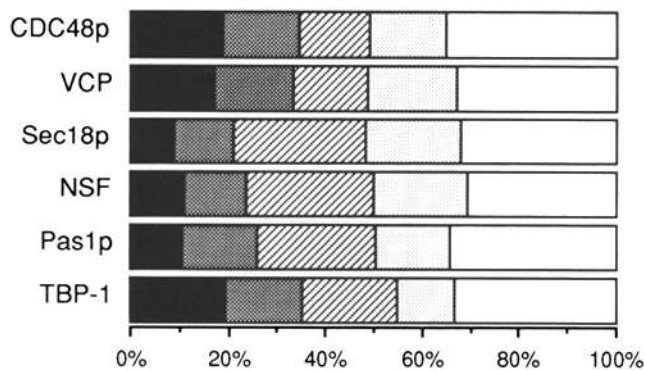

Figure 8. Amino acid composition of the amino-terminal sequence preceding the conserved region. CDC48p residues 1–208, VCP 1–199, Sec18p 1–232, NSF 1–219, Pas1p 1–421, TBP-1 1–146; acidic amino acid residues (solid bars): D and E, basic residues (dark gray bars): H, K, and R; hydrophilic residues (hatched bars): N, Q, S, and T; other residues (light gray bars): A, C, G, and P; hydrophobic residues (open bars): F, I, L, M, V, W, and Y.

content of charged amino acids, Sec18p, NSF, and Pas1p have a lesser amount of these and compensate with noncharged hydrophilic amino acids (Fig. 8). The portion of hydrophobic amino acids is very similar for all the related proteins. In addition, one acidic cluster immediately precedes the carboxy terminus of CDC48p and VCP. These regions may be responsible for the binding to a specific target, while the central region containing the nucleotide binding site could be responsible for ensuing processes common to all the proteins of the multigene family. TBP-1 also shows a high amount of charged amino acids in the aminoterminal as in CDC48p and VCP (Fig. 8). These amino acids may be involved in binding to nucleic acids and the *tat* protein.

Antibodies produced against fusion proteins from different *E. coli trpE/CDC48* gene fusions recognize a yeast protein of 115 kD and a mammalian protein of 100 kD in a Western hybridization of SDS-PAGE gels, which we assume to be VCP. Peters et al. (1990) have described the detection of a yeast protein of ~120 kD, probably CDC48p, by Western hybridization using antibodies against *Xenopus* VCP. Both CDC48p and VCP appeared to be much larger than expected from the DNA sequence data. Glycosylation and sequencing errors could be ruled out for CDC48p by tunicamycin treatment and the expression in *E. coli* of a shortened construct containing only 66 bp of yeast DNA besides the *CDC48* ORF. Both experiments still show the apparently higher molecular weight of the protein in SDS electrophoresis. Both CDC48p and VCP contain clusters of charged amino acid residues in the amino- and carboxy-terminal region, which can lead to abnormal SDS binding (Kaufmann et al., 1984; Kleinschmidt et al., 1986; See and Jackowski, 1989). The fusion proteins used for antibody production lack some or most of these highly charged regions and show smaller differences in molecular weight between the calculated and experimental SDS PAGE results (data not shown). With the corrected values for the molecular weight of the subunit, the results of the gel filtration indicate a homohexameric composition for the native soluble form.

With cell fractionation, most of CDC48p and VCP could be sedimented by centrifugation at 50,000 g, corresponding to a microsomal fraction. When the yeast spheroplasts are

disrupted by shaking with glass beads, major amounts of CDC48p are found in the 177,000-g supernatant of centrifugation, while most of the cell organelles appear to be undamaged by this treatment. This finding makes the localization of CDC48p inside of vesicles unlikely. The protein appears to be loosely bound to vesicular structures or to a large protein complex.

The observation that the spindle pole body appears to be undivided and that the microtubules are localized abnormally in mutants of *CDC48* may indicate a role for CDC48p in spindle pole proliferation. The relationship of CDC48p to Sec18p and NSF and the results of the cell fractionation experiments make a vesicle attachment appear likely. In different organisms, the centrosome is closely attached to specific vesicles or is itself based upon vesicles (Brinkley, 1985; Paweletz and Mazia, 1989). These may be the targets of CDC48p action.

We wish to thank Daphne Preuss for performing the database search and homology alignment, proofreading the manuscript, and her hospitality, Andrew Hoyt for advice and help, Kevin Hennessy and Harold Taylor for proofreading, and Alison Adams, Dave Drubin, Jan Peters, and Tim Stearns for their many suggestions.

K.-U. Fröhlich was supported by a travelling grant from the Deutsche Forschungsgemeinschaft. This work was supported by the Fonds der chemischen Industrie.

Received for publication 5 December 1990 and in revised form 23 April 1991.

References

- Barker, D. G., J. H. M. White, and L. H. Johnston. 1985. The nucleotide sequence of the DNA ligase gene (*CDC9*) from *Saccharomyces cerevisiae*: a gene which is cell-cycle regulated and induced in response to DNA damage. *Nucleic Acids Res.* 13:8323–8337.
- Beckers, C. J. M., M. R. Block, B. S. Glick, J. E. Rothman, and W. E. Balch. 1989. Vesicular transport between the endoplasmic reticulum and the Golgi stack requires the NEM-sensitive fusion protein. *Nature (Lond.)* 339:397–398.
- Bennetzen, J. L., and B. D. Hall. 1982a. Codon selection in yeast. *J. Biol. Chem.* 257:3026–3031.
- Bennetzen, J. L., and B. D. Hall. 1982b. The primary structure of the *Saccharomyces cerevisiae* gene for alcohol dehydrogenase I. *J. Biol. Chem.* 257:3018–3025.
- Bergmeyer, H. U. 1974. Methoden der enzymatischen Analyse. Verlag Chemie, Weinheim/Bergstrasse, FRG. 454–558.
- Bernardi, G. 1971. Chromatography of proteins on hydroxyapatite. *Methods Enzymol.* 22:325–339.
- Block, M. R., B. S. Glick, C. A. Wilcox, F. T. Wieland, and J. E. Rothman. 1988. Purification of an *N*-ethylmaleimide-sensitive protein catalyzing vesicular transport. *Proc. Natl. Acad. Sci. USA.* 85:7852–7856.
- Bradford, M. M. 1976. A rapid and sensitive method for the quantitation of microgram quantities of protein utilizing the principle of protein-dye binding. *Anal. Biochem.* 72:248–254.
- Brinkley, B. R. 1985. Microtubule organizing centers. *Annu. Rev. Cell Biol.* 1:145–172.
- Broach, J. R., Y.-Y. Li, L.-C. C. Wu, and M. Jayaram. 1983. Vectors for high-level, inducible expression of cloned genes in yeast. In *Experimental Manipulation of Gene Expression*. M. Inouye, editor. Academic Press, London. 83–117.
- Carle, G. F., and M. V. Olson. 1984. Separation of chromosomal DNA molecules from yeast by orthogonal-field-alternation gel electrophoresis. *Nucleic Acids Res.* 12:5647–5664.
- Carle, G. F., and M. V. Olson. 1985. An electrophoretic karyotype for yeast. *Proc. Natl. Acad. Sci. USA.* 82:3756–3760.
- Cellini, A., E. Felder, and J. J. Rossi. 1986. Yeast pre-messenger RNA splicing efficiency depends on critical spacing requirements between the branch point and 3' splice site. *EMBO (Eur. Mol. Biol. Organ.) J.* 5:1023–1030.
- Cesarone, C. F., C. Bolognesi, and L. Santi. 1979. Improved microfluorometric DNA determination in biological material using 33258 Hoechst. *Anal. Biochem.* 100:188–197.
- Clary, D. O., I. C. Griff, and J. E. Rothman. 1990. SNAPS, a family of NSF attachment proteins involved in intracellular membrane fusion in animals and yeast. *Cell.* 61:709–721.
- Diaz, R., L. S. Mayorga, P. J. Weidmann, J. E. Rothman, and P. D. Stahl.

1989. Vesicle fusion following receptor-mediated endocytosis requires a protein active in Golgi transport. *Nature (Lond.)*. 339:398-400.
- Dieckmann, C. L., and A. Tzagoloff. 1985. Assembly of the mitochondrial membrane system. *J. Biol. Chem.* 260:1513-1520.
- Dobson, M. J., M. F. Tuite, N. A. Roberts, A. J. Kingsman, and S. M. Kingsman. 1982. Conservation of high efficiency promoter sequences in *Saccharomyces cerevisiae*. *Nucleic Acids Res.* 10:2625-2637.
- Dunphy, W. G., S. R. Pfeffer, D. O. Clary, B. W. Wattenberg, B. S. Glick, and J. E. Rothman. 1986. Yeast and mammals utilize similar cytosolic components to drive protein transport through the Golgi complex. *Proc. Natl. Acad. Sci. USA*. 83:1622-1626.
- Eakle, K. A., M. Bernstein, and S. D. Emr. 1988. Characterization of a component of the yeast secretion machinery: identification of the *SEC18* gene product. *Mol. Cell. Biol.* 8:4098-4109.
- Erdmann, R., F. F. Wiebel, A. Flessau, J. Rytka, A. Beyer, K.-U. Fröhlich, and W.-H. Kunau. 1991. *PAS1*, a yeast gene required for peroxisome biogenesis, encodes a member of a novel family of putative ATPases. *Cell*. 64:499-510.
- Fleischer, S., and M. Kervina. 1974. Subcellular fractionation of rat liver. *Methods Enzymol.* 31:6-41.
- Fröhlich, K.-U., M. Wiedmann, F. Lottspeich, and D. Mecke. 1989. Substitution of a pentalenolactone-sensitive glyceraldehyde-3-phosphate dehydrogenase by a genetically distinct resistant isoform accompanies pentalenolactone production in *Streptomyces arenae*. *J. Bacteriol.* 171:6696-6702.
- Fry, D. C., S. A. Kuby, and A. S. Mildvan. 1986. ATP-binding site of adenylate kinase: mechanistic implications of its homology with *ras*-encoded p21, F₁-ATPase, and other nucleotide-binding proteins. *Proc. Natl. Acad. Sci. USA*. 83:907-911.
- Gasser, S. M. 1983. Import of polypeptides into isolated yeast mitochondria. *Methods Enzymol.* 97:329-336.
- Gebhardt, R., and W. Jung. 1982. Biliary secretion of sodium fluorescein in primary monolayer cultures of adult rat hepatocytes and its stimulation by nicotinamide. *J. Cell Sci.* 56:233-244.
- Gorbalenya, A. E., and E. V. Koonin. 1989. Viral proteins containing the purine NTP-binding sequence pattern. *Nucleic Acids Res.* 17:8413-8440.
- Guarente, L. 1984. Yeast promoters: positive and negative elements. *Cell*. 36:799-800.
- Haarer, B. K., and J. R. Pringle. 1987. Immunofluorescence localization of the *Saccharomyces cerevisiae cdc12* gene product to the vicinity of the 10-nm filaments in the mother-bud neck. *Mol. Cell. Biol.* 7:3678-3687.
- Hancock, K., and V. C. W. Tsang. 1983. India ink staining of proteins on nitrocellulose paper. *Anal. Biochem.* 133:157-162.
- Huisman, O., W. Raymond, K.-U. Fröhlich, P. Errada, N. Kleckner, D. Botstein, and M. A. Hoyt. 1987. A Tn *10-lacZ-kanR-URA3* gene fusion transposon for insertion mutagenesis and fusion analysis of yeast and bacterial genes. *Genetics*. 116:191-199.
- Ide, G. J., and C. A. Saunders. 1981. Rapid isolation of yeast nuclei. *Curr. Genet.* 4:85-90.
- Ito, H., Y. Fukada, K. Murata, and A. Kimura. 1983. Transformation of intact yeast cells treated with alkali cations. *J. Bacteriol.* 153:163-168.
- Kaiser, C. A., and R. Schekman. 1990. Distinct sets of *SEC* genes govern transport vesicle formation and fusion early in the secretory pathway. *Cell*. 61:723-733.
- Kaufmann, E., N. Geisler, and K. Weber. 1984. SDS-PAGE strongly overestimates the molecular masses of the neurofilament proteins. *FEBS (Fed. Eur. Biochem. Soc.) Lett.* 170:81-84.
- Kilmartin, J. V., and A. E. M. Adams. 1984. Structural rearrangements of tubulin and actin during the cell cycle of the yeast *Saccharomyces*. *J. Cell Biol.* 98:922-933.
- Kilmartin, J. V., B. Wright, and C. Milstein. 1982. Rat monoclonal antitubulin antibodies derived by using a new nonsecreting rat cell line. *J. Cell Biol.* 93:576-582.
- Kleinschmidt, J. A., C. Dingwall, G. Maier, and W. W. Franke. 1986. Molecular characterization of a karyophilic, histone-binding protein: cDNA cloning, amino acid sequence and expression of nuclear protein N1/N2 of *Xenopus laevis*. *EMBO (Eur. Mol. Biol. Organ.) J.* 5:3547-3552.
- Koller, K. J., and M. J. Brownstein. 1987. Use of a cDNA clone to identify a supposed precursor protein containing valosin. *Nature (Lond.)*. 325:542-545.
- Laemmli, U. K. 1970. Cleavage of structural proteins during the assembly of the head of bacteriophage T4. *Nature (Lond.)*. 227:680-685.
- Langford, C. J., F.-J. Klinz, C. Donath, and D. Gallwitz. 1984. Point mutations identify the conserved intron-contained TACTAAC box as an essential splicing signal sequence in yeast. *Cell*. 36:645-653.
- Lipman, D. J., and W. R. Pearson. 1985. Rapid and sensitive protein similarity searches. *Science (Wash. DC)*. 227:1435-1441.
- Moir, D., and D. Botstein. 1982. Determination of the order of gene function in the yeast nuclear division pathway using *cs* and *ts* mutants. *Genetics*. 100:565-577.
- Moir, D., S. E. Steward, B. C. Osmond, and D. Botstein. 1982. Cold-sensitive cell-division-cycle mutants of yeast: Isolation, properties, and pseudoreversion studies. *Genetics*. 100:547-563.
- Möller, W., and R. Amons. 1985. Phosphate-binding sequences in nucleotide-binding proteins. *FEBS (Fed. Eur. Biochem. Soc.) Lett.* 186:1-7.
- Nelbock, P., P. J. Dillon, A. Perkins, and C. A. Rosen. 1990. A cDNA for a protein that interacts with the human immunodeficiency virus *tat* transactivator. *Science (Wash. DC)*. 248:1650-1653.
- Oakley, B. R., D. R. Kirsch, and N. R. Morris. 1980. A simplified ultra-sensitive silver stain for detecting proteins in polyacrylamide gels. *Anal. Biochem.* 105:361-363.
- Paweletz, N., and D. Mazia. 1989. The fine structure of the formation of mitotic poles in fertilized eggs. In *The Cell Biology of Fertilization*. H. Schatten and G. Schatten, editors. Academic Press, Inc., San Diego. 165-187.
- Pennington, R. J. 1961. Biochemistry of dystrophic muscle. *Biochem. J.* 80:649-654.
- Peters, J.-M., M. J. Walsh, and W. W. Franke. 1990. An abundant and ubiquitous homo-oligomeric ring-shaped ATPase particle related to the putative vesicle fusion proteins Sec18p and NSF. *EMBO (Eur. Mol. Biol. Organ.) J.* 9:1757-1767.
- Rose, M. D., P. Novick, J. H. Thomas, D. Botstein, and G. R. Fink. 1987. A *Saccharomyces cerevisiae* genomic plasmid bank based on a centromere-containing shuttle vector. *Gene*. 60:237-243.
- Rothstein, R. J. 1983. One-step gene disruption in yeast. *Methods Enzymol.* 101:202-211.
- Sanger, F., S. Nicklen, and A. R. Coulson. 1977. DNA sequencing with chain-terminating inhibitors. *Proc. Natl. Acad. Sci. USA*. 74:5463-5467.
- Schwartz, D. C., and C. R. Cantor. 1984. Separation of yeast chromosome-sized DNAs by pulsed field gradient gel electrophoresis. *Cell*. 37:67-75.
- See, Y. P., and G. Jackowski. 1989. Estimating molecular weights of polypeptides by SDS gel electrophoresis. In *Protein Structure. A Practical Approach*. T. E. Creighton, editor. IRL Press, Oxford. 1-21.
- Sherman, F., G. Fink, and C. Lawrence. 1974. *Methods in Yeast Genetics*. Cold Spring Harbor Laboratory, Cold Spring Harbor, N.Y.
- Shortle, D., J. E. Haber, and D. Botstein. 1982. Lethal disruption of the yeast actin gene by integrative DNA transformation. *Science (Wash. DC)*. 217:371-373.
- Southern, E. M. 1975. Detection of specific sequences among DNA fragments separated by gel electrophoresis. *J. Mol. Biol.* 98:503-517.
- Strobel, H. W., and J. D. Dignam. 1978. Purification and properties of NADPH-cytochrome P-450 reductase. *Methods Enzymol.* 52:89-96.
- Tabor, S., and C. C. Richardson. 1985. A bacteriophage T7 RNA polymerase/promoter system for controlled exclusive expression of specific genes. *Proc. Natl. Acad. Sci. USA*. 82:1074-1078.
- Weidmann, P. J., P. Melancon, M. R. Block, and J. E. Rothman. 1989. Binding of an *N*-ethylmaleimide-sensitive fusion protein to Golgi membranes requires both a soluble protein(s) and an integral membrane receptor. *J. Cell Biol.* 108:1589-1596.
- Wilson, D. W., C. A. Wilcox, G. C. Flynn, E. Chen, W.-J. Kuang, W. J. Henzel, M. R. Block, A. Ullrich, and J. E. Rothman. 1989. A fusion protein required for vesicle-mediated transport in both mammalian cells and yeast. *Nature (Lond.)*. 339:355-359.
- Wittenberg, C., and S. I. Reed. 1989. Conservation of function and regulation within the Cdc28/*cdc2* protein kinase family: characterization of the human Cdc2Hs protein kinase in *Saccharomyces cerevisiae*. *Mol. Cell. Biol.* 9:4064-4068.
- Zaret, K. S., and F. Sherman. 1982. DNA sequence required for efficient transcription termination in yeast. *Cell*. 28:563-573.