

Zero-watt Networked Standby: Reducing Power Consumption of Home A/V Network Systems

YOSHIMICHI TANIZAWA^{1,a)} TAKESHI ISHIHARA¹ YUICHIRO OYAMA¹
TAKAOMI MURAKAMI¹ TSUYOSHI KOGAWA¹ EIJI KAMAGATA¹ KOTARO ISE¹

Received: October 15, 2012, Accepted: March 1, 2013

Abstract: Energy conservation is an important global issue. The home is the third largest energy consumer, and 10% of the home energy use is standby power of home appliances. The proliferation of home networks increases the standby power. The conventional technologies for low networked standby power such as WoL require continuous AC power, as much as 0.5 watts, to monitor wake-up signals. A large portion of the consumed power is due to the power loss in the AC-DC converter. Moreover, the technologies are applicable only to the specific network types such as Ethernet and IEEE802.11. We propose a solution to reduce the networked standby power down to zero virtually, regardless of the network type. For monitoring wake-up signals, the solution utilizes the pre-charged power in an ultra capacitor without using the AC power supply for almost all the time. In order to realize this idea, the solution also utilizes a unique and simple protocol dedicated only to the networked standby/wake-up functionality. This protocol enables the monitoring circuit to consume a very small amount of power, small enough for the capacitor to supply. The networked standby/wake-up functionality is easily combined with any conventional network application protocol by protocol address mapping. As one realization example of our solution, we implemented an experimental home A/V system which is integrated with an ultra low power wireless signal receiver and extended UPnP protocol. The system evaluation showed that our solution achieves the zero-watt networked standby while keeping network functionalities. Moreover, the analysis of the results based on a statistical survey shows that the practical networked standby power is 30mW when our solution is applied to a TV system, which corresponds to one seventeenth of a conventional technology, WoL. It means that our solution improves power consumption by 22% which corresponds to 1.11 kg-CO2 emission reduction per year per product.

Keywords: networked standby, low power consumption, UPnP, home A/V network system

1. Introduction

As the Internet Protocol (IP) technologies grow, the computer networks have been expanding rapidly. Recently, the IP technologies have enabled not only computers but also various things to be connected to networks. As the number of equipment connected to the networks increases, the necessity to reduce their energy consumption is recognized from the global warming issue.

Even in the home, appliances have been networked for better convenience, security and economy. The home network also has been a focus for measures to suppress residential energy consumption and global warming, because the residential energy consumption is the third largest electricity energy consumer [1]. A survey shows that the standby power consumption by home appliances is about 10% of total residential electricity power consumption [2], and it has been recognized that standby power reduction is important.

A number of technologies and standardized documents were reported which are based on the basic idea to shutting down the equipment while they do not offer the services, and making the equipment active by wake-up signals from other equipment or user terminals. Wake-on-LAN (WoL) [3] and Wake-on-Wireless

LAN (WoWL), a wireless equivalent of WoL are typical examples of those conventional technologies.

However, even in a shutdown state, those equipment consumes the networked standby power in order to monitor the wake-up signals from other equipment etc., and prepare to respond to service requests anytime. As an example, the WoL technology consumes as much as 0.5 W power in the networked standby mode [4]. In spite of the improvement of conventional technologies, all of the technologies consume networked standby power which is fed by continuous AC power supply. **Figure 1** illustrates the block diagram of typical conventional technologies.

In addition to the standby power issue, the conventional technologies have the drawback that they can be applicable only to specific network technologies such as Ethernet and

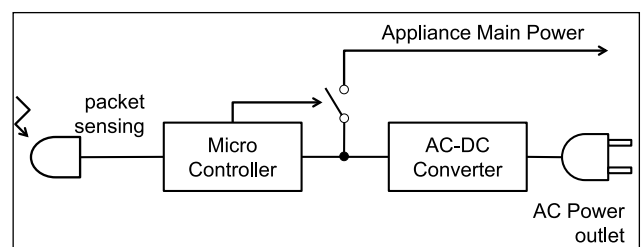

Fig. 1 Block diagram of typical conventional technologies.

¹ TOSHIBA Corporation, Kawasaki, Kanagawa 212–8582, Japan

^{a)} yoshimichi.tanizawa@toshiba.co.jp

IEEE802.11 [5], [6]. In order to get rid of this drawback, an approach which provides each kind of network with a wake-up signal monitor is reported [7]. This approach has another drawback that it is not applicable to wireless networks.

In the case of residential networks, it is a quite important characteristic that the power reduction technology is applicable to any kind of network technologies, different from the conventional technologies. This is because various kinds of networks for home video, air-conditioning, lighting and home security, for example, exist in homes and these networks support various kinds of network technologies.

We propose a solution to reduce the networked home appliance standby power down virtually to zero. And the solution is applicable to any kind of network technologies, different from the conventional technologies.

The solution utilizes the pre-charged power in an ultra capacitor for monitoring wake-up triggers in the networked standby mode, without using AC power almost all the time. The AC power is required only when the capacitor is charging. Because most of the networked standby power is due to the AC-DC converter power losses, the idea which activates the AC-DC converter only for short periods of time reduces the networked standby power down to virtually zero.

In order to realize practical networked standby which lasts a sufficiently long time only using the pre-charged power, the monitoring circuit running in networked standby mode should consume low power and be small. That is, the monitoring circuit should have low processing power. It is difficult for such a low spec. monitoring circuit to receive high-speed (high bit rate) wake-up triggers in networked standby mode. So, the wake-up signal should be transmitted and received at a lower speed (low bit rate). However, when the receiving time of the wake-up trigger at the monitoring circuit becomes longer, the total energy consumption of receiving the wake-up trigger is increased. Therefore, the wake-up signal should be kept shorter and simpler.

In order to meet the above requirements, the solution also utilizes a unique and simple protocol dedicated only to the wake-up/termination signals. This protocol keeps the minimum addressing function and enables the monitoring circuit size to be small, and for the circuit to consume very little power, enough for the capacitor to supply. In theory, the practical networked standby power of our solution is 0.3875 mWh, 1/1,290 of the conventional technology, WoL [4].

The networked standby/wake-up functionality has to be able to be combined with any conventional network application protocol, and this is realized by protocol address mapping. The mapping connects the wake-up addresses to which the wake-up signals are sent and the corresponding home appliance addresses.

As one realization example of our solution, we implemented an experimental system. The system uses an ultra low power wireless wake-up detection IC our research group developed [8], [9] as the monitoring circuit. In order to run the applications which are designed to run on a major home network protocol Universal Plug and Play (UPnP) [10], the system is integrated with expanded UPnP protocol.

The system evaluation showed that our solution achieves the

zero-watt networked standby while keeping network functionalities. Moreover, the analysis of the results based on a statistical survey [2] shows that the practical networked standby power is 30 mW when our solution is applied to a TV system, which corresponds to one seventeenth of the conventional technology, WoL. It means that our solution improves power consumption by 22% which corresponds to 1.11 kg-CO₂ emission reduction per year per product.

The rest of this paper is as follows: Section 2 describes our target system and its requirements. Section 3 details our solution. Section 4 explains the implementation of our experimental system and discusses our solution design. In Section 5, the experimental system is evaluated. Section 6 describes related work and Section 7 summarizes our proposal.

2. Target System and Requirements

This section explains our research target system and its requirements.

Figure 2 shows the target home network system we focus on. The target system is a home A/V network system which consists of two types of networked equipment: home terminal equipment and home server equipment. The networked equipment communicates across the network. IEEE802.11 is an example of the network. The target system enables a home user to browse A/V content such as a movie stored in the home server equipment using the home terminal equipment. The movie data are transmitted from the home server equipment to the home terminal equipment as streaming data.

The home server equipment has at least two power status modes: active mode and networked standby mode. In active mode, the home server equipment works and transmits the movie data to the home terminal equipment, for example. In networked standby mode, the home server equipment stops and waits for wake-up triggers, consuming lower power than in active mode. When receiving the wake-up triggers, the home server equipment in networked standby mode moves to active mode.

The home terminal equipment is operated by the user. To provide services to the user, the home terminal equipment communicates with the network server equipment through the network. When the home server equipment is in networked standby mode, the home terminal equipment sends some kinds of wake-up triggers to the home server equipment in order to move the home server equipment to active mode.

Next, we describe the design requirements of the target system

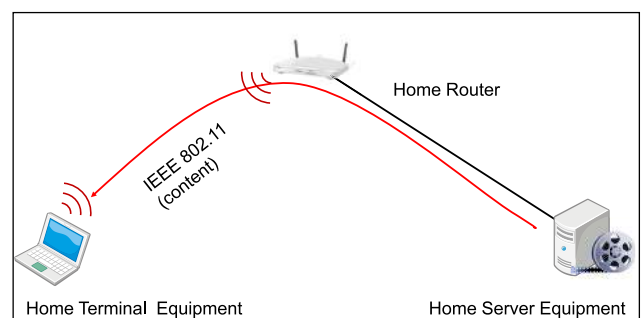

Fig. 2 Target home network system.

for our proposed solution.

The solution should achieve almost no power consumption by the home server equipment in networked standby mode.

In addition, the solution should be practical in two respects. One is that the solution should be applicable to any kind of network technologies. In detail, the solution should co-exist with the existing home network equipment and its technologies, and should be easy to integrate with existing devices/solutions. The other is that the solution should be available in all of the typical home environments. In detail, the solution should support the typical number of home network equipment in a noisy home environment, and should cover the typical distance between the home terminal equipment and home server equipment.

3. Proposed Solution

This section explains our proposed solution.

The solution equips the home server equipment with a power control module (PCM). The PCM is inserted between the AC power outlet and the home server equipment. The PCM acts like a power switch of the home server equipment. In networked standby mode the PCM switches off the AC power supply to the home server equipment, so the home server equipment in networked standby mode, including its AC-DC converter, consumes no AC power.

Since the home server equipment in networked standby mode is powered off completely, the PCM monitors wake-up triggers on behalf of the home server equipment. The PCM utilizes the pre-charged power in an ultra capacitor to monitor the wake-up triggers. The PCM is driven only by the power from the ultra capacitor and uses no AC power almost all of the time. The AC power is required only when the capacitor is charging. Because a large part of the networked standby power is due to the AC-DC converter power losses, the idea which activates the AC-DC converter only in short time reduces the networked standby power down virtually to zero.

In order to realize practical networked standby which lasts a sufficiently long time only using the pre-charged power, the PCM should consume low power and be small. That is, the PCM should have low processing power. It is difficult for such a PCM to receive high-speed (high bit rate) wake-up triggers in networked standby mode. So, the wake-up signal should be transmitted and received at a lower speed (low bit rate). However, when the receiving time of the wake-up trigger at the PCM becomes longer, the total energy consumed on the PCM when receiving the wake-up trigger is increased. Therefore, the wake-up signal should be kept shorter and simpler.

In order to meet the above requirements, the PCM also utilizes a unique and simple protocol, called wake-up protocol. The wake-up protocol is designed to be dedicated only to the wake-up/termination functionality. This protocol keeps minimum addressing functionalities and enables the monitoring circuit size to be small, and for the circuit to consume very little power, enough for the ultra capacitor to supply.

On the other hand, the solution equips the home terminal equipment with a wake-up signal transmission module (WTM) in order to wake up/terminate the home server equipment re-

motely. The WTM sends wake-up triggers or termination triggers based on the wake-up protocol to the PCM connected to the target home server equipment. The wake-up protocol is transmitted as IEEE802.11 frame, the existing technology, for simple implementation and easy deployment. The WTM identifies the target PCM by its wake-up address, an identifier of the PCM. The wake-up address is included in the wake-up trigger and the termination trigger. Any kind of wake-up address assignment method would be applicable. For example, DHCP servers could assign a wake-up address the same as an IP address.

The wake-up protocol is independent of the conventional network protocols used for the networked equipment communication. In order to integrate the wake-up protocol and the conventional network protocols, the solution utilizes discovery mechanisms and address mapping provided by the conventional network protocols. UPnP is a typical example of the conventional network protocols.

Our solution uses a service/device discovery mechanism of the network protocols to convey the power status mode (active mode or networked standby mode) and wake-up method descriptions of the home server equipment to the home terminal equipment. In our solution, the description at least includes the wake-up address of the PCM connected to the corresponding home server equipment. So the home terminal equipment receiving the description maps the network address (usually IP address) and the wake-up address easily. Introducing a general wake-up method description enables our solution to be more flexible and makes our solution adaptable to a wide variety of wake-up methods. The home terminal equipment performs the wake-up protocol based on the received description when the target home server equipment is in networked standby mode.

Here, we show the typical use case of our solution. The home terminal equipment is running applications. When the home terminal equipment is required by a user to browse a movie, it refers the list of contents and selects a home server equipment which holds the corresponding movie. Then the home terminal equipment refers to the power status mode of the target home server equipment. If the target home server equipment is in networked standby mode, the home terminal equipment refers to the wake-up method and the wake-up address, and starts wake up of the target home server equipment by using its WTM. Then the wake-up protocol runs to wake up the target home server equipment using its PCM. After confirming active mode of the home server equipment, the home terminal equipment requests the movie data through the network to the home server equipment. After receiving all the movie data, the home terminal equipment terminates the home server equipment, in a similar way. **Figure 3** illustrates the concept of our solution.

As our solution is so simple and doesn't depend on A/V features, it is also applicable to various networked appliances and devices other than the A/V system described in the above use-case.

4. Implementation

We implemented an experimental system as an example of our solution. The implementation consists of the following items: the

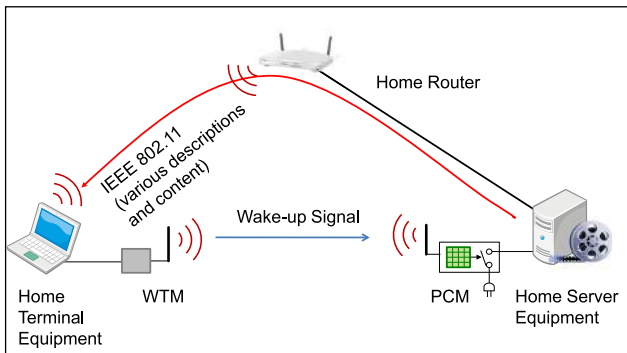

Fig. 3 Concept of our solution.

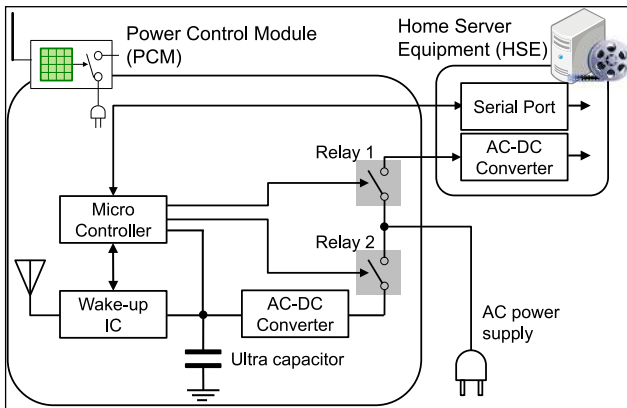

Fig. 4 Structure of PCM and parts of HSE.

PCM, the wake-up protocol, the WTM, the network protocol, the home server equipment, and the home terminal equipment. This section describes the implementation of these items, respectively, and discusses the wake-up protocol design.

4.1 Power Control Module (PCM)

The PCM is inserted between an AC power outlet and the home server equipment. The PCM is powered from the AC outlet and supplies AC power to the home server equipment. The PCM is also connected to the home server equipment with a serial connection. Figure 4 illustrates the structure of the PCM and parts of the home server equipment.

The PCM switches the AC power relay (Relay 1 in Fig. 4) on to start supplying AC power to the connected home server equipment when detecting wake-up signals. At the same time, the PCM switches the ultra capacitor relay (Relay 2 in Fig. 4) on, to start charging the ultra capacitor. After finishing charging, the PCM switches the ultra capacitor relay off. At this point, the PCM itself is driven only by the ultra capacitor power supply. So, when the PCM switches the AC power relay off, both the PCM and the connected home server equipment consume no AC power, waiting for wake-up signals in networked standby mode. When a controller in the PCM judges that remaining power in the ultra capacitor is close to zero, the PCM switches the ultra capacitor relay on, leaving the AC power supply relay off, to re-charge the ultra capacitor. In this situation, the PCM consumes a little AC power while the home server equipment is in the networked standby mode. However, we can avoid these kinds of situations in the usual case by planning an appropriate capacitance of the

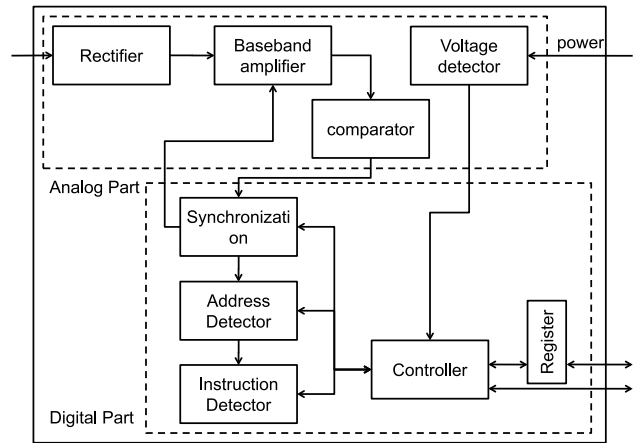

Fig. 5 Wake-up IC structure.

ultra capacitor.

The following equation expresses the charge movement in the running PCM.

$$(E1 - E2) \cdot C = I \cdot T$$

$E1 (= 5 V)$ stands for the charge voltage of the ultra capacitor. $E2 (= 2.3 V)$ and $I (= 15 \mu A)$ stand for the running voltage and the consumption current (maximum) of the PCM, respectively. $C (F)$ stands for the capacitance of the ultra capacitor and T (seconds) stands for the running time of the PCM with the charged ultra capacitor. T is calculated by the derived equation below.

$$T = 2.7 \cdot C / (5 \cdot 10^{-6})$$

When using two ultra capacitors (EECS5R5V115 [11]) connected in parallel, C is 3 F and T is 540,000 seconds. And the result of our preliminary experiment showed that the time required to fill up the ultra capacitor charge in the PCM was about 8 minutes and the consumed energy was 58 mWh. This means that the ultra capacitor charging during the networked standby mode is not required if the home server equipment runs at least 8 minutes in 6 days, and that the averaged networked standby power consumption is 0.3875 mW in theory. It is nearly 1/1,290 of the power consumption of WoL [4].

Next, we explain a wake-up IC [8], [9], a component in the PCM. Figure 5 illustrates the wake-up IC structure. The wake-up IC is a low power wireless signal receiver involving a high sensitivity rectifier and an amplifier. Since the wake-up IC has very simple functionality, the current consumption of the wake-up IC is 6 μA [12]. When receiving wireless signals based on wake-up protocol, the wake-up IC performs address detection and instruction detection.

The wake-up IC outputs pulse signals depending on the result of instruction detection only if the result of address detection matches the assigned wake-up address. When the instruction is wake-up, the wake-up IC outputs a wake-up request signal. When the instruction is termination, the wake-up IC outputs a termination request signal. The serial port connected to the home server conveys the pulse signals between the PCM and the home server equipment. After outputting the termination request signal, the PCM waits for a termination response signal from the home server equipment. When the termination response signal is



Fig. 6 Appearance of PCM.

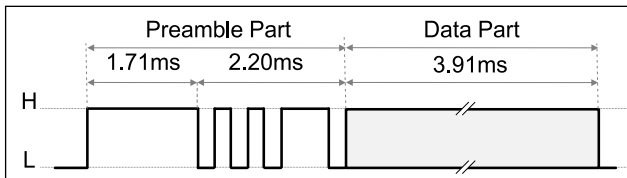

Fig. 7 Format of wake-up signal.

Table 1 Functions of the data part.

Name	Bit length	Function
Wake-up address bit	3	To identify the wake-up address of the target PCM.
Instruction bit	1	To indicate the instruction (wake-up or termination).
Parity bit	2	To detect error.
Reserved bit	2	For future use.

received, the PCM switches the AC power relay off to stop supplying AC power to the home server equipment.

Figure 6 shows the appearance of PCM.

4.2 Wake-up Protocol

The wake-up protocol is used to wake up/terminate the home server equipment assigned with the wake-up address. Figure 7 shows the frame format of the wake-up signal based on the wake-up protocol. The wake-up signal consists of a preamble part and a data part. The preamble part is a continuous signal, and its signal pattern never appears in the data part. The preamble part is used for automatic gain control adjustment and bit synchronization. The data part again consists of wake-up address bits, instruction bits, parity bits, and reserved bits. The functions of the data part are shown in Table 1. Each bit is coded in 2-ary pulse position modulation (PPM).

To make the protocol simple and the signal short, the length of instruction bits is only 1 bit for 2 instructions: wake-up and termination, and the length of wake-up address bits is 3 bits which identifies 8 addresses in one home network system. A protocol design trade-off is discussed later. There is an example reference of home network technology which communicates with up to 8 addresses using 3 bit address length: Bluetooth piconet [13]. In order to support more than 8 wake-up addresses, duplicated address assignment is possible if the home server equipment provides the basic security mechanisms described below.

Next, we consider security issues of the wake-up protocol. The wake-up protocol is so simple that it provides no security mechanism. Therefore, the application and the application protocol supported by the home server equipment should provide

security functionalities. Attackers may easily wake up or terminate the home server equipment identified in the falsified wake-up/termination instruction and other systems may perform wake-up/termination instruction using the same wake-up address. The home server equipment takes several measures against the above situations to prevent false operations.

As a countermeasure against the falsified wake-up instruction, the home server equipment supports device authentication before providing its services. If the device authentication fails or there is no access during a certain period of time, the home server equipment shall terminate automatically. The falsified termination instruction attack is regarded as a kind of DoS attacks. The countermeasures against the falsified termination instruction are to ignore the termination instruction while other home terminal equipment uses the services of the home server equipment, or to ignore the termination instruction right after the wake-up of the home server equipment.

4.3 Protocol Design Discussion

Here power consumption trade-off in the wake-up protocol design is discussed.

Our solution is address-length independent. Since the experimental system adopts a 3 bit length wake-up address, there are possible address length designs based on use-case. In our solution, the design of wake-up address length affects power consumption with the following three main parameters.

The first parameter is the maximum addressing number of the wake-up address. If the address length becomes longer, the number of assignable wake-up addresses will increase. With the increase of the number of assignable addresses, the flexibility of the system configuration increases. On the other hand, if the address length becomes shorter, the number of assignable addresses will decrease. The decrease of the number of assignable addresses increases the possibility of address collision. Address collision happens when two or more home server equipment are assigned to the same wake-up address in the range of wake-up signal from the home terminal equipment, causing a false wake-up of home server equipment. In order to work around the false wake-up, the home server equipment (immediately after wake-up) determines whether this wake-up is a false wake-up or not by checking the condition of the home server equipment and UPnP protocol and so on. If the home server equipment finds it is a false wake-up, the equipment immediately starts to terminate. The workaround for the address collision/false wake-up brings an energy consumption increase.

The energy consumption overhead of the workaround, Oh (Ws), is described in the following equation, where P (W) stands for the power consumption of home server equipment, and T_s , T_d , and T_t (seconds) stand for the time period of wake-up, false wake-up check, and termination, respectively.

$$Oh = (T_s + T_d + T_t) \cdot P$$

Since extra energy is consumed, the protocol design should avoid shorter address which causes frequent address collision.

The second parameter is the interference probability of the wake-up signal. If the address length increases and the radio

signal becomes long, the radio signal interference probability increases. When the interference occurs and the signal error cannot be corrected, the PCM cannot detect wake-up protocol. So in the noisy environment WTM should resend the wake-up signal several times, consuming additional power at the home terminal equipment side.

For example, some types of wireless keyboards and general home use products, such as microwave ovens transmit 2.4 GHz radio wave regularly during operation, which preliminary experiments reveal become possible sources of interference. When using a shorter address length, the wake-up signal becomes shorter and decreases the probability of interference.

The third parameter is PCM energy consumption in wake-up signal receiving period. When using a longer address, the wake-up signal also becomes longer and the PCM circuit becomes more complex and runs for a longer time in the receiving process. As a result, PCM power and energy consumption required in the wake-up signal receiving process increase. When using a shorter address, the wake-up signal also becomes shorter and the PCM circuit becomes simpler and runs for a shorter time in the receiving process. As a result PCM power and energy consumption required in the wake-up signal receiving process decreases.

However, the above argument is only valid when developing a custom PCM circuit. For example, a microcontroller in the PCM configured for supporting a shorter address doesn't decrease its power consumption. This is because in this configuration, even though the address detection process in the digital part becomes smaller, the major analog part performs almost the same process without dependence on the address length.

The above three parameters should be considered in wake-up address design. The experimental system, referring to the existing technology of Bluetooth piconet design [13], adopts 3-bit address in 8-bit wake-up address, which can specify 8 PCMs, at a maximum. This is on the assumption that address collision probability is low enough in a general home environment that the system can distinguish 8 home server equipment in one home.

Next, we discuss the transmission rate of the radio wake-up signals. The discussion questions which communication is more power consumption effective, high speed short period communication or low speed long period communication.

In our solution, the most power effective transmission rate is determined from the microcontroller receiving processing speed and the power consumption specification of the microcontroller. The solution selects the combination of wake-up signal transmission rate and microcontroller power consumption which minimizes microcontroller energy $C \cdot (B/A)$ (Ws), which is consumed in receiving wake-up protocol, where A (bps) is the wake-up signal transmission rate, B (bit) is the wake-up signal bit length, and C (W) is the microcontroller power consumption when performing B/A (seconds) receiving process. It is assumed that B is already decided by the address length design discussion. In the experimental system case, the low power microcontroller [30] (i.e., C W) was selected at first, and then the wake-up signal transmission rate (A bps) available on the microcontroller was decided.

4.4 Wake-up Signal Transmission Module (WTM)

The WTM is connected to the home terminal equipment by its USB port and transmits wake-up signals based on the wake-up protocol. Figure 8 shows the WTM structure.

A WLAN I/F and IEEE802.11 frame are utilized for simple implementation and easy deployment. That is, the WTM transmits formatted wake-up signals by transmitting IEEE802.11 frames in proper timing, data length, and transmission rate. Recall the wake-up signal format is based on pulse position modulation.

To avoid interference and noise, the WTM adopts two mechanisms: NAV and retransmission. NAV (Network Allocation Vector) in IEEE802.11 specification is a virtual carrier sense mechanism. Every IEEE802.11 frame transmitted by the WTM includes a proper NAV duration value in the MAC header. Other IEEE802.11 devices suppress frame transmissions in the NAV duration time of the received frame. So this mechanism helps the IEEE802.11 devices to avoid collision with the wake-up signals from the WTM. And retransmission of the wake-up signal is an effective mechanism to avoid a noise signal in general. The results of our preliminary experiments show that the wake-up signal with NAV and 32 times retransmission in 256 msec is detected by the PCM properly in 94% of cases at a typical home environment which includes other IEEE802.11 and wireless devices (microwave oven, etc.).

Figure 9 shows the appearance of WTM.

4.5 Integration of Network Protocols

The PCM and the WTM should be integrated with network protocols to enable the application to utilize the networked standby/wake-up functionality. As there are some candidate network protocols, the experimental system adopts UPnP [10], because it is commonly used in home network applications. Table 2 shows the UPnP specifications and functionalities each networked equipment supports in the experimental system.

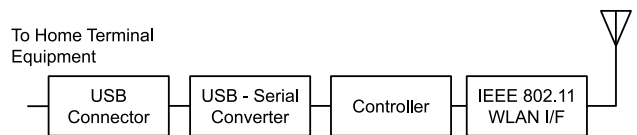

Fig. 8 WTM structure.



Fig. 9 Appearance of WTM.

Table 2 UPnP specifications and functionalities.

Supported specification	Functionalities of HTE	Functionalities of HSE
UPnP-AV	Media Renderer	Media Server
UPnP Low Power	Low Power-aware Control Point	Low Power device

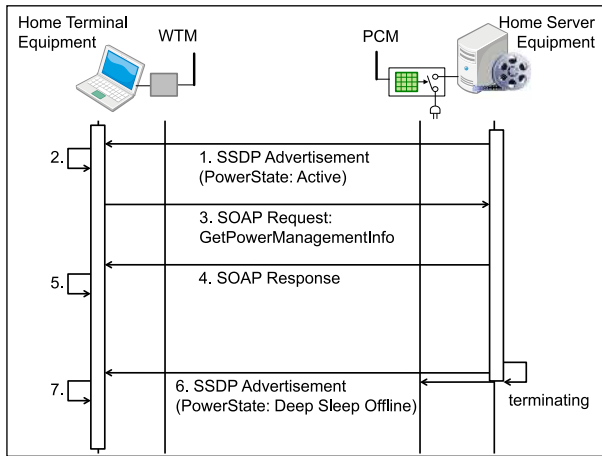

Fig. 10 Sequence of our experimental system (the first half).

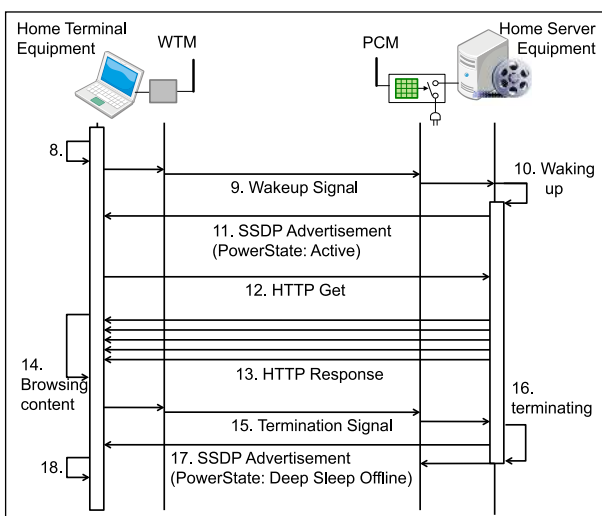

Fig. 11 Sequence of our experimental system (the second half).

UPnP-AV specification is to handle digital A/V contents in UPnP networks. UPnP Low Power specification is to support conventional wake-up mechanisms such as WoL for the UPnP devices [14]. However, there is no proper implementation of UPnP Low Power available in general, and the specification doesn't support the wake-up mechanism using the wake-up IC in our solution. So, the experimental system implemented UPnP Low Power specification and was extended to support our wake-up mechanism.

Figures 10 and 11 illustrate the detailed sequence of the experimental system.

1. The home server equipment periodically broadcasts SSDP (Simple Service Discovery Protocol) Advertisement messages to advertise UPnP-AV service (Connection Manager:1 and Content Directory:1) and UPnP Low Power service (Low Power Devices:1) as its services. The header of the SSDP Advertisement messages includes power status mode (active) of the low power device, that is, the home server equipment.
2. Receiving the SSDP Advertisement messages, the home terminal equipment, which is already set up in the home network, holds the information about the UPnP functionalities of the corresponding home server equipment and the power

status mode, based on the received messages. And the home terminal equipment links the information to the Identifier of UPnP.

3. When detecting the corresponding home server equipment supporting the Low Power device functionality, the home terminal equipment sends to it a SOAP request message to inquire the supported wake-up methods.
4. The home server equipment receives the SOAP request message and sends a SOAP response message to inform the supported wake-up method and the wake-up address of the connected PCM to the corresponding home terminal equipment. This action is defined as GetPowerManagement action in the UPnP Low Power specification.
5. The home terminal equipment receives the message and links the supported wake-up method information and the wake-up address to the corresponding Identifier of UPnP.
6. When the home server equipment begins to move to the networked standby mode, it broadcasts the SSDP Advertisement messages, including the header indicating its power status mode as DeepSleepOffline, that is, the networked standby. The home server equipment outputs the termination response signal to the PCM, and the PCM switches the AC power relay off. At this point, the home server equipment consumes no AC power.
7. Receiving the SSDP Advertisement message, the home terminal equipment updates the power status mode information of the corresponding home server equipment.
8. When the user wants to browse and select movie content, the home terminal equipment finds the location of the content firstly by searching its content caches and identifies the home server equipment which holds the movie data. Then, it reads the power status mode of the corresponding home server equipment.
9. If the corresponding home server equipment is in the networked standby mode, the home terminal equipment also reads the wake-up method and wake-up address of the home server equipment. If the corresponding home server equipment supports the method using the wake-up IC, the home terminal equipment transmits a formatted wake-up signal including the wake-up address using its WTM.
10. When the PCM, connected to the corresponding home server equipment, detects the wake-up signal, the PCM starts to supply AC power to the home server equipment by controlling its relay. At the same time, the home server equipment begins to wake up.
11. When finishing the wake-up process, the home server equipment starts to broadcast SSDP Advertisement messages, the same as the sequence 1.
12. Detecting the wake-up of the corresponding home server equipment, the home terminal equipment sends a HTTP request message to the home terminal equipment in order to start downloading the target movie data.
13. Receiving the HTTP request message, the home server equipment starts to send the corresponding movie data in HTTP response messages to the home terminal equipment.
14. While downloading the movie data in the HTTP response

Table 3 Implementation spec. of HSE.

Part	Name	Specification/Version
Hardware	KURO-BO X/PRO	Marvell 88F5182 400MHz, 128MB RAM, GbE, 64GB SSD
OS	Debian GNU/Linux	5.0 (lenny/sid)
UPnP software (Media Server)	MediaTomb	0.12.1 (modified)

messages, the home terminal equipment starts to play the movie data on its display.

15. After receiving all the movie data, the home terminal equipment transmits a formatted termination signal using its WTM.
16. When the corresponding PCM detects the termination signal, the PCM outputs the termination request signal to the home server equipment through the serial connection. The home server equipment starts to terminate.
17. The home server equipment broadcasts the SSDP Advertisement messages, the same as sequence 6. Before finishing the termination process, the home server equipment outputs the termination response signal to the PCM. Then, the PCM stops supplying AC power to the home server equipment by controlling its relay.
18. The home terminal equipment updates the power status mode information, the same as sequence 7.

The above is the detailed sequence of our experimental system.

4.6 Home Server Equipment

Table 3 shows the implementation specification of the home server equipment.

In order that the home server equipment provides Low Power device functionality defined in UPnP Low Power specification [14] and supports the proposed wake-up mechanism, UPnP Media Server and its library software were modified. The following are the modified points: (1) to include the power status mode information in SSDP Advertisement messages, (2) to send supported wake-up method information and wake-up address based on the GetPowerManagementInfo action, (3) to be started and terminated by the PCM.

About (1), a UPnP library in MediaTomb [15], named libupnp [16] adds a power status mode management unit. The unit indicates either Active mode or DeepSleepOffline mode defined in the UPnP Low Power. The SSDP Advertisement header includes Active mode when the home server equipment is running, while DeepSleepOffline mode when the home server equipment begins to terminate. In the experimental system, DeepSleepOffline mode is considered as the networked standby mode.

About (2), the SOAP library in the libupnp is used to implement the GetPowerManagement action. In the action, wake-up method information is represented in an XML-formatted document. So we define a new XML document which represents the wake-up IC method. The wake-up address information is also included in the XML document. Figures 12 and 13 show the ex-

```
<?xml version="1.0" encoding="UTF-8"?>
<p:WakeupMethod
  xmlns:p="urn:schemas-upnp-org:lp:WakeupMethod"
  xmlns:xsi="http://www.w3.org/2001/XMLSchema-instance">
  <p:NonBearerWakeupMethod>
    <p:BearerType>LPWIC</p:BearerType>
    <p:VendorNonBearerInfo>
      &lt;?xml version="1.0"?>?&gt;
      &lt;q:Id xmlns:q="WakeupMethodLPWIC"&gt;
        1
      &lt;/q:Id&gt;
    </p:VendorNonBearerInfo>
  </p:NonBearerWakeupMethod>
</p:WakeupMethod>
```

Fig. 12 XML document representing the wake-up IC method.

```
<xsd:schema xmlns:xsd="http://www.w3.org/2001/XMLSchema"
  xmlns="WakeupMethodLPWIC"
  targetNamespace="WakeupMethodLPWIC"
  elementFormDefault="qualified">
  <xsd:element name="Id">
    <xsd:simpleType>
      <xsd:restriction base="xsd:nonNegativeInteger">
        <xsd:maxInclusive value="7" />
        <xsd:minInclusive value="0" />
      </xsd:restriction>
    </xsd:simpleType>
  </xsd:element>
```

Fig. 13 XML Schema document.

Table 4 Implementation spec. of HTE.

Part	Name	Specification/Version
Hardware	Toshiba Dynabook SS RX2	Intel Core2 duo SU9300 1.2GHz, 2GB RAM, GbE, 160GB HDD
OS	Ubuntu Linux	7.0 .4
UPnP software (Media Renderer)	Xbmc	9.11 (modified)

ample XML document and the corresponding XML Schema document, respectively. The wake-up IC method is embedded as a new Non Bearer Wakeup Method in UPnP Low Power specification, so the current implementation supports 3 types of wake-up method at least: WoL, RF remote controller, and our wake-up IC.

About (3), the configuration of the power supply circuit in the home server equipment enables the PCM to boot the home server equipment just by supplying AC power. The serial connection between the PCM and the home server equipment enables the graceful shutdown of the home server equipment. When receiving the termination request signal from the serial port, the home server equipment starts the shutdown action. After finishing the shutdown action, the home server equipment outputs the termination response signal through the serial port.

4.7 Home Terminal Equipment

Table 4 shows the implementation specification of the home terminal equipment.

In order that the home terminal equipment provides Low Power-aware Control Point functionality defined in UPnP Low

Power specification [14] and supports the proposed wake-up mechanism, UPnP Media Renderer software and its library software were modified. The following are the modified points: (1) to maintain the information of the power status mode of the Low Power devices, (2) to get and hold the information on the wake-up method of each Low Power device, (3) to identify the target home server equipment and transmit the wake-up signal automatically when it is required by UPnP applications.

About (1), an UPnP library in Xbmc [17], named Platinum UPnP [18] add a Low Power device information management class. The power status mode information is obtained in the header of the received SSDP Advertisement messages.

About (2), the SOAP message exchange function is used to implement the GetPowerManagementInfo action. The Low Power device information management class maintains the wake-up method information, which is obtained in the XML document in the received SOAP messages. The implementation performs the action, following the reception of SSDP Advertise messages from a new Low Power device, while the action timing is unspecified in the UPnP Low Power specification.

About (3), an abstract class representing general wake-up methods is introduced. Some pure virtual functions are implemented for each concrete wake-up method (WoL, RF remote controller, and wake-up IC). For the wake-up IC, the initialization process, reset process, wake-up process, and termination process are implemented as the WTM interface processing. The above implementation enables the UPnP applications to use wake-up functionality seamlessly, regardless of the type of the wake-up method the home terminal equipment supports. The home terminal equipment performs the wake-up functionality, just prior to performing UPnP action and requesting services based on UPnP (ex., HTTP request).

Moreover, in order to identify the target home server equipment, the home terminal equipment is required to support a content cache mechanism which links each content information to the corresponding home server equipment. The mechanism is originally provided by Xbmc.

5. Evaluation

We evaluated our solution by using our experimental system in terms of the following five points: wake-up delay, home server equipment power consumption, home terminal equipment power consumption, effectiveness assessment of energy reduction, and system-wide energy reduction.

5.1 Wake-up Delay Evaluation

We evaluated the wake-up delay that is the period between the time the home terminal equipment transmits the wake-up signal and the time the home terminal equipment receives the first movie data, in our experimental system by monitoring its network traffic. The result shows the home server equipment wake-up delay takes 17.0 seconds and the TCP retransmission delay on the home terminal equipment after detecting the wake-up of the home server equipment takes 6.8 seconds. These delays can be shortened in several ways. For example, hibernation or instant-on functionalities, and network parameter tuning of UPnP/TCP can

improve the total wake-up delay.

On the other hand, the result of wireless traffic monitoring and the observation of the home server equipment also show the delay overhead of our solution. This consists of retransmission of the wake-up signal, detection of the wake-up signal by the wake-up IC, and the controlling of the AC power relay in the PCM, and is less than 1 second in total, which is negligible.

Figure 14 summarizes the wake-up delay evaluation results.

5.2 Power Consumption of Home Server Equipment

We evaluated the power consumption both in networked standby mode and in active mode of the home server equipment. The evaluation results are shown in Table 5. The power consumption in this section is measured based on the standardized measurement (specified as direct meter reading method and average reading method) described in IEC 62301 [19].

The measured networked standby power consumption shows our implementation achieves zero-watt networked standby. It proves that the AC power supply is completely disconnected when the PCM turns the AC power relay off, and that the PCM is running only by the power supplied from the ultra capacitor. The power consumption in active mode shows that there is an additional 0.15 W constant overhead by inserting the PCM. Figure 15 summarizes the power consumption impact of PCM.

The 0.15 W constant overhead seems to be caused by the miscellaneous circuits of the PCM (the serial port, the status LED, etc.), because the required energy for charging the ultra capaci-

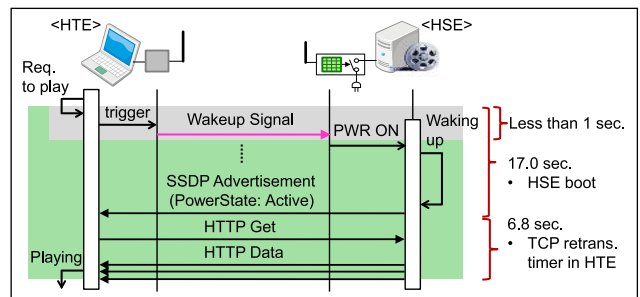

Fig. 14 Wake-up delay evaluation.

Table 5 Evaluated power consumption of HSE.

Mode	Power Consumption
Networked standby	0.000W
Active (with PCM)	8.030W
Active (without PCM)	7.880W

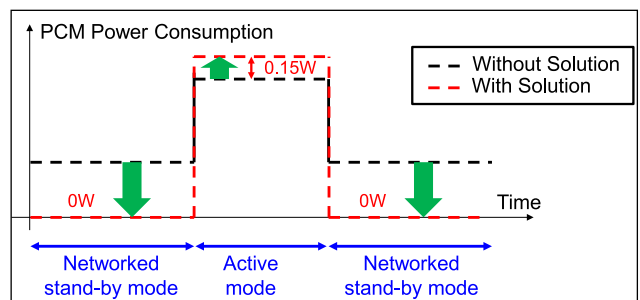

Fig. 15 Power consumption impact of PCM.

Table 6 Estimated power consumption of HSE.

Mode	Existing Product	Product with our solution
Networked standby	0.5W	0W
Active	8.0W	8.15W

tor is only 58 mWh and takes 8 minutes according to the result of our preliminary experiment stated in Section 4. A survey [2] shows the average daily TV viewing time is 4 hours and for the rest of the time, the TV is in standby mode or switched off. From the survey and the evaluation results considering the overhead in active mode, the calculated practical networked standby power is 30 mW, when the solution is applied to a TV system. This corresponds to one seventeenth of the WoL standby power consumption [4].

Next, we explain the relationship between the evaluation result and EuP (directive on Eco-Design of Energy-using Products [20], [21]) in EU. EuP regulates products with high standby power [22] or high networked standby power. But the regulation about the networked standby power is under review in Lot 26 [4]. The definition of the “networked standby” in Lot 26 seems to be applicable to the proposed networked standby solution in this paper. And the power consumption evaluation method we used is based on IEC 62301 [19], which is recommended in Lot 6 [2], the basis of Lot 26. This indicates that our solution is the zero-watt networked standby complying with EuP requirement.

5.3 Power Consumption of Home Terminal Equipment

The power consumption evaluation of the home terminal equipment shows that the overhead of connecting the WTM is 0.27 W and that the overhead of transmitting a wake-up signal per hour is 0.77 mW. The former overhead is mainly because of the USB style module implementation. The WTM functionality can be implemented by using an existing WLAN Interface. So the former overhead is negligible. The latter overhead is slight and also negligible practically when the WTM functionality is implemented using the existing WLAN Interface.

5.4 Effectiveness Assessment of Energy Reduction

On the assumption that our solution is adopted in a common home server equipment, we assess the effectiveness of energy reduction and CO2 emission limitation. The survey [4] describes that one of the best available products of home server equipment in terms of networked standby power is the Buffalo LS-WSX500L/R1EU [23]. **Table 6** shows the specification both of the power consumption of the existing product, and the estimated power consumption of a product with our solution. Here we use a current minimum power consumption value as the power consumption of networked standby mode (with WoL) in the existing product, referring the document [4].

Since the survey [2] shows the average daily TV viewing time is 4 hours, we can obtain the energy consumption per year per product shown in **Table 7** from the above assumption. These results show that our solution reduces energy consumption by 3,431 Wh per year per product and improves the power consump-

Table 7 Estimated energy consumption.

	Existing Product	Product with our solution
Energy consumption per year per product	15,330Wh	11,899Wh

tion by 22%. Moreover, when considering an emission intensity 0.324 kg-CO₂/kWh, which is the FY2009 value reported by Tokyo Electric Power Company [24], the CO₂ emission reduction of our solution per year per product is 1.11 kg-CO₂.

5.5 System-wide Evaluation

In order to evaluate the effectiveness of our solution in system-wide and more general situations, we assess the power reduction per day in a general home environment where there are several items of home server equipment. This assessment also considers the possibility of address collision which causes false wake-up of the home server equipment with a fixed probability. The false wake-up is caused by the wake-up signal from the home terminal equipment in neighboring houses and brings energy consumption overhead.

At first, the energy consumption reduction per day without false wake-up $Er1$ (Wh) is considered. $Er1$ is calculated by the below equation, where N is the number of home server equipment in one home, Tr (hours) is the total time each home server equipment is active per day, and the power consumption of each equipment is from Table 6.

$$Er1 = N \cdot (24 - Tr) \cdot 0.5 - N \cdot Tr \cdot 0.15$$

Next, assuming that false wake-up happens f times per day, the energy consumption reduction per day with false-wake-up $Er2$ (Wh) is considered. $Er2$ is calculated by the below equation, where Ts , Td , and Tt (seconds) are time period of wake-up, false wake-up check, and termination of each home server equipment, and energy consumption overhead is calculated as per Section 4.3 discussion.

$$Er2 = N \cdot (24 - Tr) \cdot 0.5 - N \cdot Tr \cdot 0.15 - ((Ts + Td + Tr)/(60 \cdot 60)) \cdot 8.15 \cdot f$$

Here, assuming Tr is the same value as the TV case in Section 5.2, Ts and Tt are the same as in Section 5.1, Td is 0, and N is 3, $Er2$ is calculated as $(28.20 - 0.054 \cdot f)$. Since the false wake-up time is short, the energy consumption impact of false wake-up is limited if the number of f is small. For example, $Er2$ is 28.15 Wh when $f = 1$ and $Er2$ is 27.7 Wh when $f = 10$.

Finally, f , the false wake-up frequency per day, is discussed. How much the wake-up signal coverage area is overlapped with the neighboring house (neighboring home network) is the first important factor. When the overlapped ratio with the house i is S_i ($0 \leq S_i \leq 1$), the position of each home server equipment is uniformly distributed and other conditions are equal, f is proportional to S_i .

On the other hand, f' , the false wake-up frequency per day in case that the coverage area is completely overlapped with coverage area of house i , is considered. Where B is the maximum addressing number by the wake-up protocol, and N_i ($0 \leq N_i \leq B$)

is the number of home server equipment deployed in house i , the expectation value of the number of home server equipment which assigned collision address with house i is calculated as $N_i \cdot N/B$. When assuming C_i is the number of wake-up signals from house i in the case that the wake-up signal is transmitted to each N_i home server equipment randomly, f' is calculated by the equation.

$$f' = \frac{N}{B} \sum_i C_i$$

As a result, f is considered as below.

$$f = \frac{N}{B} \sum_i S_i C_i$$

In our experimental system, it is assumed that N is less than 8, C_i is less than 10, and S_i is almost zero. So the design can select B as 8 (address length is 3-bit). However, the above equation of f can be an address length design guideline for each use-cases. In an environment with larger C_i (wake-up/termination occurs very frequently) or another environment with larger N_i (many devices should be controlled), B should be designed as a larger value to keep a similar size of f . For example, when C_i is 1,000 times larger or N_i is 1,000 times larger, the maximum addressing number B should be 1,000 times larger. This means that the address bits should be increased by 10 bits in the wake-up signal design.

6. Related Work

Several related works mainly focus on the office environment. Microsoft Research [5] illustrates introducing WoL proxy functionality in the large scale office. Existing WoL technology and the proxy architecture are optimized for the large scale office. Some works introduce the proxy functionality [5], [6]. However, deploying the new equipment which is required to be always in active mode is difficult in home network environments, because no equipment/network management is expected. Somniloquy [25] adopts a smart NIC (Network Interface Card) approach. In networked standby mode, only the smart NIC performs communications, while the main CPU sleeps. This approach also balances the service availability and low power consumption in networked standby. However, the approach doesn't minimize the networked standby power.

Other related works focus on the home network environment. Some works [6], [26] combine WoL technology and application protocols, and manage the power status mode of remote devices to wake-up the target remote device with proper timing. However, WoL is only applicable to specific network technologies such as Ethernet and IEEE802.11. Since home networks are already deployed with various network technologies, so the networked standby/wake-up functionality should be applicable to the various network technologies. LBNL [7] proposes a low power A/V system that wakes-up only when detecting wired connection signal (HDMI, monitor cable, etc.). However, the approach doesn't address wireless networks and doesn't achieve low power networked standby in wireless networks. Our solution utilizes the media-independent unique wake-up protocol. The architecture enables it to be easily combined with any network type: wired or wireless.

Some alternative approaches adopt low power wireless technologies, such as IEEE802.15.4, as the wake-up trigger to wake up the functionality of WLAN or other network protocols [27], [28]. These approaches are similar to our approach. However, IEEE802.15.4 and the other similar standardized wireless technologies need inactive periods to realize low power consumption. So the technologies cause a wake-up timing delay or require timing synchronization for communications. And as such it is difficult to deploy the technologies in home network environments. Our wake-up protocol is dedicated only to wake-up/termination functionality and has a very simple implementation. So the wake-up protocol has no inactive periods and is easy to deploy in home networks.

RF-ID passive tags or some similar technologies may be a future candidate for purely zero-watt networked standby [29]. However these current technologies consume larger power on the transmitter side and only support short distances. Additionally, because of poor addressing features, these technologies alone cannot be a practical approach for networked standby in home network environments for the time being at least.

7. Summary

In this paper, we focus on the home A/V network system, and propose a zero-watt networked standby solution. For monitoring the wake-up signal, the solution utilizes the pre-charged power in an ultra capacitor without using an AC power supply for almost all the time. In order to realize this idea, the solution also utilizes a unique and simple protocol dedicated only to the networked standby/wake-up functionality. This protocol keeps minimum addressing functionalities and enables the monitoring circuit to consume very little power, enough for the capacitor to supply. The networked standby/wake-up functionality is easily combined with any conventional network application protocol by protocol address mapping. Since our solution doesn't depend on A/V specific features, it is applicable to various networked appliances.

As one realization example of our solution, we implemented an experimental home A/V system. The system uses the ultra low power wireless wake-up detection IC we developed as the monitoring circuit. In order to run the UPnP applications, the system is integrated with an expanded UPnP protocol.

The system evaluation shows that our solution achieves the zero-watt networked standby while keeping network functionalities. Moreover, the analysis of the results based on the statistical survey in Ref. [2] shows that the practical networked standby power is 30 mW when our solution is applied to a TV system, which is one seventeenth of the conventional technology, WoL. This means that our solution improves the total power consumption of a practical home server product by 22% which corresponds to 1.11 kg-CO₂ emission reduction per year per product.

Acknowledgments This project was partly supported by the Ministry of International Affairs and Communications, Japan.

References

- [1] International Energy Agency: Electricity/Heat in World in 2008, available from (<http://www.iea.org/stats/>).
- [2] Nissen, N.F.: EuP Preparatory study Lot 6: Standby and Off-mode

- Losses Final Report (2007).
- [3] Wake-on-LAN, available from (<http://en.wikipedia.org/wiki/Wake-on-LAN>).
- [4] Nissen, N.F.: EuP Preparatory study Lot 26: Networked Standby Losses Final Report (2010).
- [5] Reich, J., Goraczko, M., Kansal, A. and Padhye, J.: Sleepless in Seattle No Longer, *USENIX ATC* (2010).
- [6] Klamra, J., Olsson, M., Christensen, K. and Nordman, B.: Design and Implementation of a Power Management Proxy for Universal Plug and Play, *Proc. Swedish National Computer Networking Workshop (SNCW 2005)* (2005).
- [7] Nordman, B. and Lanzisera, S.: Inter-device power management for audio/video equipment, *2011 IEEE International Conference on Consumer Electronics (ICCE)*, pp.243–244 (2011).
- [8] Umeda, T. and Otaka, S.: ECO chip: Energy consumption zeroize chip with a 953 MHz high-sensitivity radio wave detector for standby mode applications, *IEEE Custom Integrated Circuits Conference*, pp.663–666 (2007).
- [9] Umeda, T., Yoshida, H., Sekine, S., Fujita, Y., Suzuki, T. and Otaka, S.: A 950-MHz rectifier circuit for sensor network tags with 10-m distance, *IEEE Journal of Solid-State Circuits*, Vol.41, No.1, pp.35–41 (Jan. 2006).
- [10] UPnP Forum: UPnP: Universal Plug and Play, available from (<http://www.upnp.org>).
- [11] Panasonic Corporation: EEC5R5V155 (2010), available from (<http://industrial.panasonic.com/www-cgi/jvcr13pz.cgi?E+PZ+3+ABC0002+EECS5R5V155+7+WW>).
- [12] Kogawa, T., Ishihara, T., Ogura, K., Umeda, T. and Sakamoto, T.: Low Power Consumption Wireless Wake-up Module Controlling AC Power Supply at Household Appliances, *Proc. 15th IEEE International Symposium on Consumer Electronics* (2011).
- [13] Bluetooth Special Interest Group: Specification of Bluetooth System 2.0.
- [14] UPnP Forum: UPnP Low Power Architecture (Aug. 2007).
- [15] MediaTomb, available from (<http://mediatomb.cc/>).
- [16] libupnp, available from (<http://pupnp.sourceforge.net/>).
- [17] Xmbc, available from (<http://xbmc.org/>).
- [18] Platinum UPnP, available from (<http://sourceforge.net/projects/platinum/>).
- [19] International Electrotechnical Commission: IEC EN 62301: Household electrical appliances – Measurement of standby power (2009).
- [20] Directive 2005/32/EC of the European Parliament and of the Council of 6 July 2005.
- [21] Directive 2009/125/EC of the European Parliament and of the Council of 21 October 2009.
- [22] Commission Regulation (EC) No 1275/2008 of 17 December 2008 (“standby regulation”).
- [23] Buffalo Inc.: LS-WSX500L/R1EU (2010), available from (<http://www.buffalo-technology.com/products/network-storage/linkstation/ls-wsxl-linkstation-mini/>).
- [24] Tokyo Electric Power Company (TEPCO): Sustainability Report 2010, p.29 (Sep. 2010), available from (<http://www.tepco.co.jp/en/challenge/environ/pdf-1/10report-e.pdf>).
- [25] Agarwal, Y., Hodges, S., Chandra, R., Scott, J., Bahl, P. and Gupta, R.: Somniloquy: Augmenting network interfaces to reduce pc energy usage, *NSDI '09*, Berkeley, CA, USA (2009).
- [26] Apple Inc.: Mac OS X v10.6: About Wake on Demand, available from (<http://support.apple.com/kb/HT3774>).
- [27] Mishra, N., Chebrolu, K., Raman, B. and Pathak, A.: Wake-on-WLAN, *Proc. 15th International Conference on World Wide Web, WWW '06*, New York, NY, USA, pp.761–769, ACM (2006).
- [28] Shih, E., Bahl, P. and Sinclair, M.J.: Wake on wireless: An event driven energy saving strategy for battery operated devices, *Proc. 8th Annual International Conference on Mobile Computing and Networking, MobiCom '02*, New York, NY, USA, pp.160–171, ACM (2002).
- [29] Siwamogsatham, S., Rattanawan, P., Kitjaroen, M., Songtung, P., Pongpaibool, P. and Navanugraha, K.: Smartly saving energy with a zero power consumption standby system, *Proc. Technology Management in the Energy Smart World (PICMET '11)*, pp.1–4 (2011).
- [30] Microchip Technology Inc.: PIC18F46J50-I/PT.



Yoshimichi Tanizawa received his M.S. degree from Keio University, Japan, in 2002. He joined TOSHIBA Corporation in 2002, and has been engaged in research on network systems and low power network technologies. He received the Best Paper Award at the SAINT 2012 (The 12th IEEE/IPSJ International Symposium on Applications and the Internet).



Takeshi Ishihara received his M.E. degree from Tokyo Institute of Technology, Japan, in 2001. He joined TOSHIBA Corporation in 2001, and has been engaged in research on IPv6, networked appliances, and low power network technologies.



Yuichiro Oyama received his M.E. degree from Kyushu University, Japan, in 2008. He joined TOSHIBA Corporation in 2008, and has been engaged in research on low power network technologies.



Takaomi Murakami received his M.S. degree from Hokkaido University, Japan, in 2009. He joined TOSHIBA Corporation in 2009, and has been engaged in research on low power network technologies.



Tsuyoshi Kogawa received his M.S. degree from Tohoku University, Japan, in 2002. He joined TOSHIBA Corporation in 2002, and has been engaged in research on wireless communication systems.



Eiji Kamagata received his M.E. degree from Waseda University, Japan, in 1989. He joined TOSHIBA Corporation in 1989, and has been engaged in the development of power control computer systems.



Kotaro Ise received his M.S. degree from Kobe University, Japan, in 1992. He joined TOSHIBA Corporation in 1992, and has been engaged in research and development on high speed communication nodes, especially MPLS routers. His research interest includes high performance communication technologies and wireless

communications.