

**LOS ALAMOS
SCIENTIFIC LABORATORY**

**OF THE UNIVERSITY OF CALIFORNIA
LOS ALAMOS, NEW MEXICO**



**CONTRACT W-7405-ENG.36 WITH THE
U.S. ATOMIC ENERGY COMMISSION**

DISCLAIMER

This report was prepared as an account of work sponsored by an agency of the United States Government. Neither the United States Government nor any agency Thereof, nor any of their employees, makes any warranty, express or implied, or assumes any legal liability or responsibility for the accuracy, completeness, or usefulness of any information, apparatus, product, or process disclosed, or represents that its use would not infringe privately owned rights. Reference herein to any specific commercial product, process, or service by trade name, trademark, manufacturer, or otherwise does not necessarily constitute or imply its endorsement, recommendation, or favoring by the United States Government or any agency thereof. The views and opinions of authors expressed herein do not necessarily state or reflect those of the United States Government or any agency thereof.

DISCLAIMER

Portions of this document may be illegible in electronic image products. Images are produced from the best available original document.

LOS ALAMOS SCIENTIFIC LABORATORY
of the
UNIVERSITY OF CALIFORNIA

Report written:
May 1954

Report distributed: AUG 20 1954

HECU-2913
(LA-1663)

ZnS (Ag) PHOSPHOR MIXTURES FOR
NEUTRON SCINTILLATION COUNTING

Work done by:

P. G. Koontz*
G. R. Keepin
J. E. Ashley

Report written by:

P. G. Koontz*
G. R. Keepin

PHYSICS

*On leave from the College of Wooster, Wooster, Ohio.

ABSTRACT

Various zinc sulfide phosphor mixtures for neutron scintillation counting have been compared. Selected compounds of hydrogen, lithium, boron, and fissionable elements were mixed in varying proportions with ZnS(Ag), and the corresponding neutron and γ counting efficiencies measured as functions of energy. It was found that the 1:1.5 boric acid - ZnS mixture gave the highest neutron counting efficiency of the combinations tested. The low sensitivity of these mixtures to γ 's (10^{-5} to $10^{-4}\%$) and the measured short time decay constant ($\tau = 0.04 \mu\text{sec}$) offer distinct advantages for fast neutron counting.

CONTENTS

Abstract	2
Introduction	4
Section 1. Measurement of Light-Decay Constant of ZnS	4
Section 2. Survey of ZnS(Ag) Neutron Detecting Mixtures	6
2.1 ZnS(Ag) Powder	9
2.2 Hydrogenous Compounds	9
2.3 Lithium Compounds	10
2.4 Boron Compounds	10
2.5 Uranium Compounds	13
Section 3. Summary and Conclusions	14

TABLES

Table 1	Counting Efficiencies (in per cent) for ZnS(Ag) Powdered Phosphor Detector	9
Table 2	Counting Efficiencies (in per cent) for ZnS-Lucite Detector	9
Table 3	Counting Efficiencies (in per cent) for Optimum LiF-ZnS Scintillation Detector	10
Table 4	Counting Efficiencies (in per cent) for Optimum Boron-ZnS Scintillation Detector	13
Table 5	Counting Efficiencies (in per cent) for Optimum Uranium-ZnS Scintillation Detector	14

ILLUSTRATIONS

Fig. 1	α particle pulses from silver-activated zinc sulfide photographed with a 513 Tektronix scope	5
Fig. 2	α particle pulses from silver-activated zinc sulfide photographed with a 517 Tektronix scope	5
Fig. 3	Neutron counting rates for various polythene geometries	7
Fig. 4	Standard counting geometry and method of mounting phosphor mixtures	8
Fig. 5	Neutron counting rate vs thickness for various mixtures of ZnS and LiF	11
Fig. 6	Neutron counting rate vs thickness for optimum atomic ratios of various ZnS-boron compound mixtures	12
Fig. 7	Neutron and γ counting efficiencies as a function of energy for various optimum detectors in standard geometry	15
Fig. 8	Counting efficiencies as a function of bias voltage (background corrected)	16

Introduction

Because of its high light output and relatively large conversion efficiency for heavy particles compared to electrons (from γ 's), silver-activated zinc sulfide phosphors have recently received increased attention, particularly for neutron counting applications. (1-8)

The main disadvantage of the ZnS(Ag) phosphor (especially for coincidence counting applications) has been its long light-decay constant, reported in references to earlier work⁽⁹⁻¹²⁾ as $\sim 10^{-5}$ sec. Preliminary studies, however, indicated a principal decay component approximately two orders of magnitude smaller than this, in agreement with more recent measurements of τ_{ZnS} (6, 7, 13, 14). Thus, ZnS(Ag) phosphors appeared sufficiently promising to warrant a brief survey of various detector mixtures using ZnS(Ag) as the phosphorescent component; we have confined our attention to neutron detection with a view toward development of a short-time-resolution scintillation counter with maximum ratio of neutron-to- γ counting efficiency in the fission energy range.

1. Measurement of Light-Decay Constant of ZnS

The time-decay constant of ZnS, τ , was determined by measurements on photographs of individual pulses obtained with a fast scope. If the anode time constant of the photomultiplier is short compared to τ , the observed decay time should be that of the phosphor except for distortions introduced by the amplifying system. Thus, for example, the amplifier rise time should be short compared to τ . To test these effects, τ has been measured using both "slow" and "fast" electronic equipment.

The "slow" system, a Tektronix Model 513 Scope preceded by a Los Alamos Model 503 amplifier and preamplifier, had a rise time of ~ 0.07 μsec . The anode resistor, R , of the photomultiplier -- a DuMont 6292 selected for low noise -- was varied from 1 megohm to 62 ohms. The observed pulse width decreased with R for $10^6 > R > 10^3$ and remained essentially constant for $R \leq 10^3$ ohms. Figures 1a and b show pulses obtained with 510 ohms and 62 ohms, respectively, together with 10-Mc calibrations. The initial decay obtained from an average of twelve pulses ($R = 240$ ohms) corresponds to $\tau \cong 0.1$ μsec , and for the tail, $\tau \cong 0.4$ μsec .

The "fast" system consisted of a Tektronix Model 517 Scope preceded by one stage of a Hewlett-Packard Model 460A distributed amplifier. These instruments have rise times of 0.007 and 0.0026 μsec , respectively. The photomultiplier anode time constant was made ≤ 0.005 μsec . Figure 2 shows a photograph of an α pulse together with a 100-Mc time signal. No appreciable difference in decay constant was observed for α or γ pulses. A decay curve plotted for the average of eight α pulses corresponds to $\tau \cong 0.04$ μsec . Larger values of τ_{ZnS} reported in earlier literature may be attributable to slower electronics and the use of

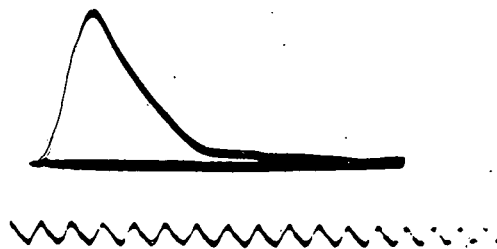

Fig. 1a

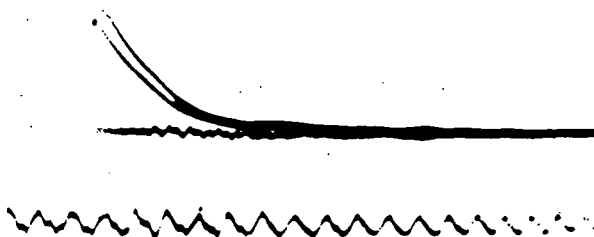

Fig. 1b



Fig. 2

Fig. 1 α particle pulses from silver-activated zinc sulfide photographed with a 513 Tektronix scope. Time calibration: 10^7 cps. Photomultiplier anode resistor: (a) 510 ohms, (b) 62 ohms.

Fig. 2 α particle pulses from silver-activated zinc sulfide photographed with a 517 Tektronix scope. Time calibration: 10^8 cps.

"adulterated" ZnS(Ag) phosphors. Observation of scope pulses indicated the same decay constant for both RCA 33-Z-20A and DuPont 1101 phosphors.

A check of counting loss for ZnS mixtures using the Model 503 amplifier indicated a negligible loss up to 20,000 cps. A loss of $\sim 1\%$ at 30,000 cps may be attributable to resolution of the scaler rather than the phosphor.

2. Survey of ZnS(Ag) Neutron Detecting Mixtures

The present survey is divided into five categories depending on the neutron reaction used for detection:

1. ZnS(Ag) powdered phosphor alone [S(n,p)P³²]
2. ZnS(Ag) + hydrogenous compounds [(n,p) scattering]
3. ZnS(Ag) + Lithium compounds [Li⁶(n, α)H³]
4. ZnS(Ag) + Boron compounds [B¹⁰(n, α)Li⁷]
5. ZnS(Ag) + Uranium and thorium compounds [U(n,f)]

For a reliable intercomparison among these five groups it is essential to standardize certain parameters which are to be kept constant throughout the survey. Accordingly, a "standard geometry" and "standard gain" were selected in the following manner: with a Po-LiF neutron source (average energy, 0.7 Mev) placed 6 in. above the photomultiplier cathode, curves of counting rate (at any appropriate gain and bias) vs polythene moderator thickness were run for three values of polythene diameter. (See Fig. 3, which also includes one curve for Po-Li neutrons of average energy ~ 0.4 Mev.) The detector used for these tests was 120 mg/cm² of 1:1.5 boric acid-ZnS powder mixture.* Inspection of Fig. 3 shows that with the polythene diameters used, optimum efficiency is obtained with a polythene cylinder 3-7/8 in. in diameter and 2-1/4 in. thick. This established a "standard counting geometry" -- including moderator, unless otherwise indicated -- as shown in Fig. 4. Using this geometry, a "standard gain" was established as that gain for which at a bias of 10 volts (arbitrary), the counting rate in a given Cs¹³⁷ γ flux is 0.01% of the counting rate in an equal Po-LiF neutron flux. This gain was checked (by standard γ count) before and after each run and except where otherwise indicated was used throughout the subsequent work. Counting efficiency is taken simply as the ratio of counting rate to flux incident on the detecting phosphor. In determining γ counting efficiencies no attempt has been made to differentiate between γ pulses from the phosphor and those originating in the tube itself. There is evidence of appreciable tube contribution during γ counting.

*The ratio 1: 1.5 refers to atoms of boron per molecule of ZnS; the powder mixture is retained on the photocathode by an aluminum annulus arrangement (3.8-cm ID) and an aluminum reflector foil. (See Fig. 4).

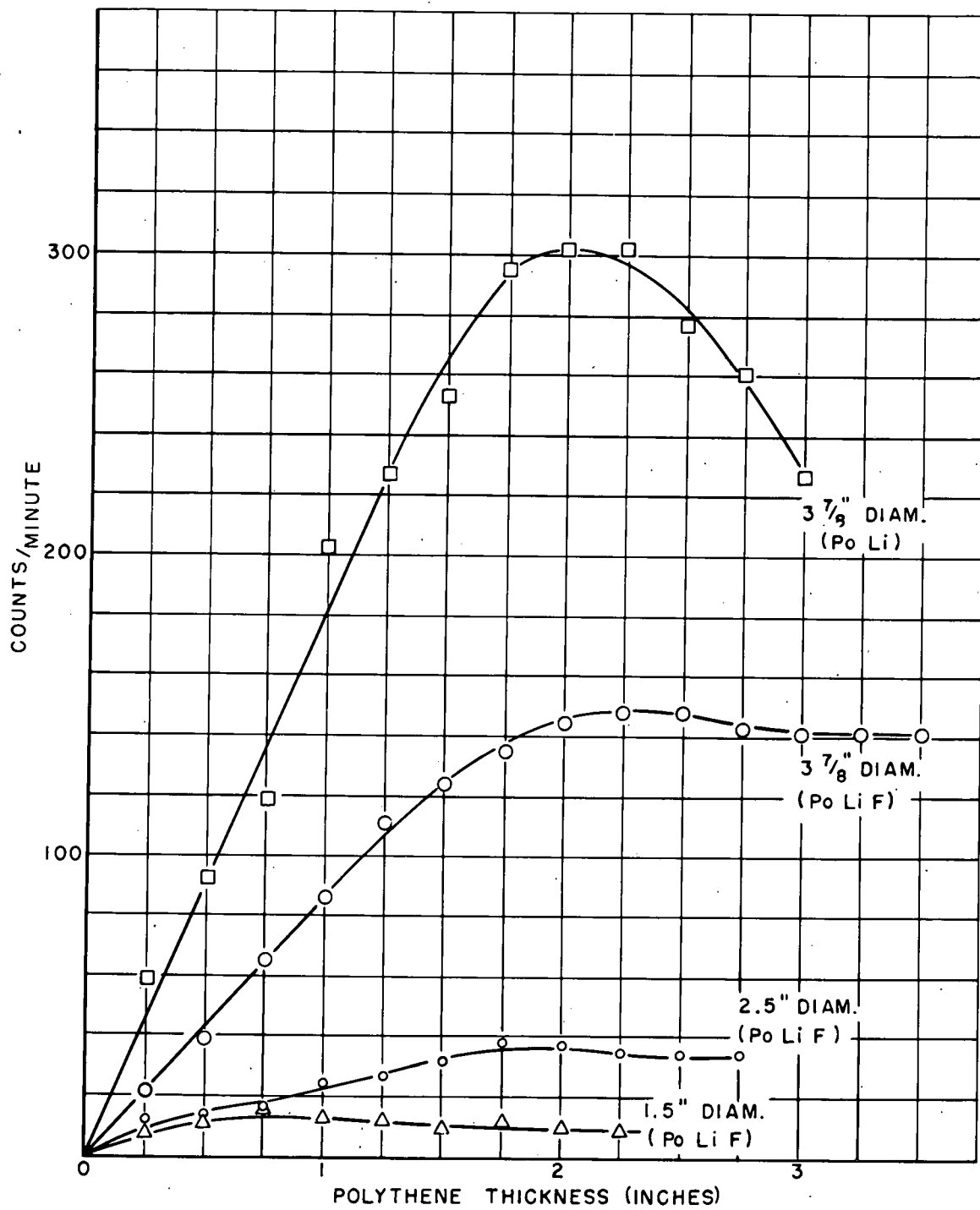

Fig. 3 Neutron counting rates for various polythene geometries.

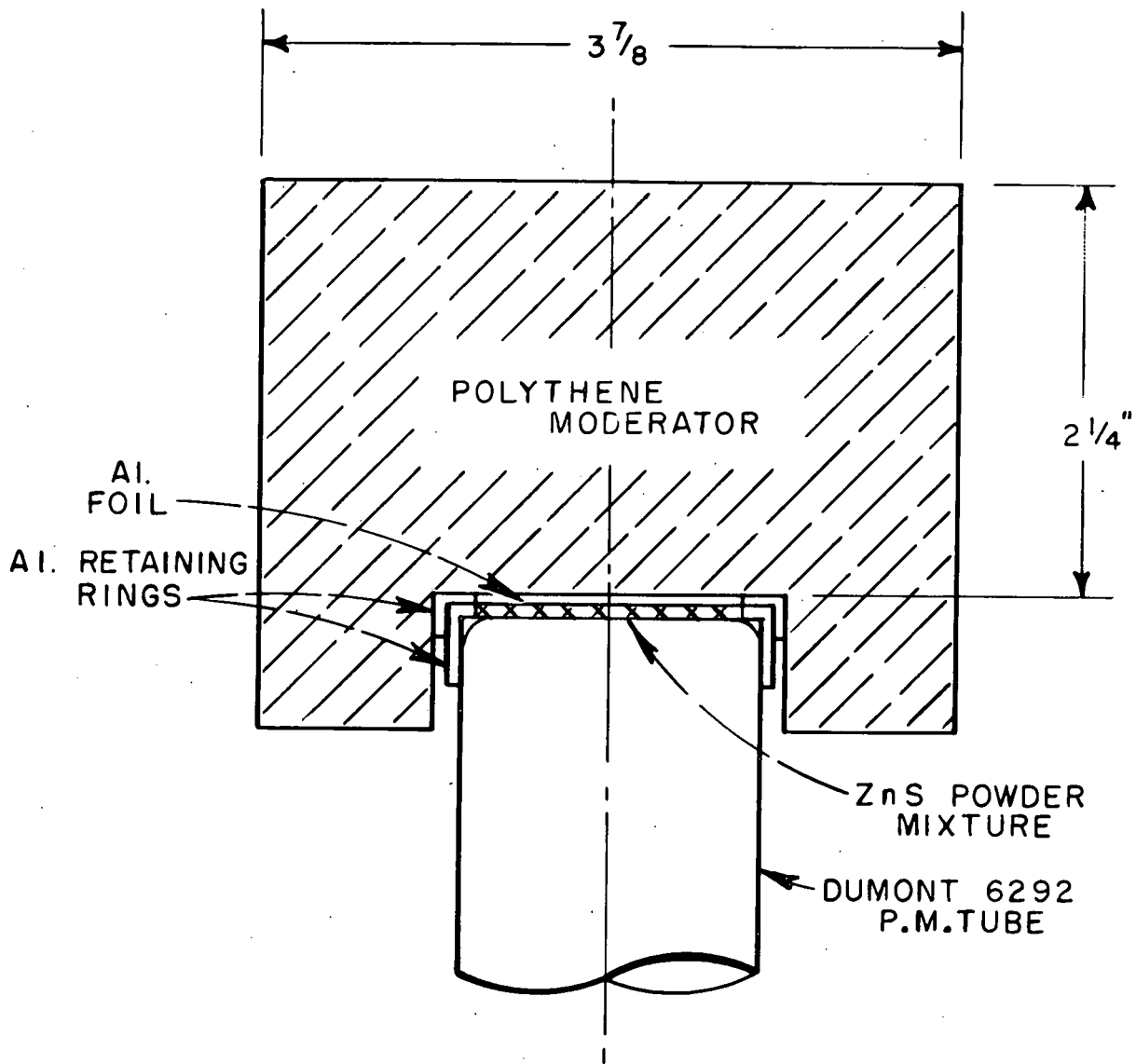

Fig. 4 Standard counting geometry and method of mounting phosphor mixtures.

2.1 ZnS(Ag) Powder*

The S(n,p) threshold reaction ($Q = -0.93$ Mev) for neutron scintillation counting has been previously investigated.⁽¹⁵⁾ The neutron counting efficiency, ϵ_n , rises from zero at threshold (~ 2 Mev) to $\sim 0.03\%$ for Po-Be neutrons ($\bar{E}_n \approx 4.0$ Mev). This value of ϵ_n was determined with a Po-Be source in standard geometry (excluding polythene moderator in this case) and using standard gain. Representative values of neutron and γ counting efficiencies (in per cent) for this detector are given in Table 1. The average neutron energy for the Po-LiF spectrum above the S(n,p) threshold is taken as 2.2 Mev.

TABLE 1
COUNTING EFFICIENCIES (IN PER CENT) FOR ZnS(Ag)
POWDERED PHOSPHOR DETECTOR

$\bar{E}_n \approx 0.4$ Mev (Po-Li)	$\bar{E}_n \approx 2.2$ Mev (Po-LiF)	$\bar{E}_n \approx 4.0$ Mev (Po-Be)	$E_\gamma = 0.19$ Mev (In ¹¹⁴)	$E_\gamma = 0.66$ Mev (Cs ¹³⁷)	$\bar{E}_\gamma \approx 1.8$ Mev (Ra γ)
0	~ 0.005	~ 0.03	$\sim 0.8 \times 10^{-5}$	$\sim 8 \times 10^{-5}$	$\sim 1 \times 10^{-4}$

2.2 Hydrogenous Compounds

Neutron detection by the (n,p) scattering process in mixtures of ZnS(Ag) with hydrogenous compounds has also been studied recently.^(13, 14) Using a ZnS-lucite detector** in standard geometry (excluding the polythene moderator in this case) and using standard gain, representative values of neutron and γ counting efficiencies were measured. These values are presented in Table 2.

TABLE 2
COUNTING EFFICIENCIES (IN PER CENT) FOR ZnS-LUCITE DETECTOR

$\bar{E}_n \approx 0.4$ Mev (Po-Li)	$\bar{E}_n \approx 0.7$ Mev (Po-LiF)	$\bar{E}_n \approx 4.0$ Mev (Po-Be)	$E_\gamma = 0.19$ Mev (In ¹¹⁴)	$E_\gamma = 0.66$ Mev (Cs ¹³⁷)	$\bar{E}_\gamma \approx 1.8$ Mev (Ra γ)
0.05	0.1	0.3	$\sim 0.8 \times 10^{-5}$	$\sim 8 \times 10^{-5}$	$\sim 1.0 \times 10^{-4}$

* RCA Phosphor No. 33-Z-20A; 40 mg/cm² uniformly deposited on photocathode from a CC1₄ suspension. This RCA phosphor was used throughout these studies.

**A molded cylinder, 1-1/2 in. in diameter and 1/4 in. thick, containing 2.9 grams of ZnS in 8.3 grams of lucite.

Using a mixture of ZnS and paraffin with appropriate lucite light guides, Emmerich⁽¹⁴⁾ has more than tripled the neutron counting efficiency of the ZnS-lucite detector with no appreciable increase in γ counting efficiency.

2.3 Lithium Compounds

ZnS(Ag) has been mixed in varying atomic ratios with three lithium compounds, LiCl, LiF, and Li₂CO₃, selected for high atomic percentage of lithium, crystalline form and color, and availability. Using a Po-LiF source in standard geometry and with standard gain, curves of counting rate vs thickness of mixture were then determined for each atomic ratio for the three lithium compounds. Figure 5 shows the results for the most favorable compound, LiF. Similar curves were obtained for LiCl and Li₂CO₃. A maximum counting rate was obtained with 120 mg/cm² of a 2:1 LiF-ZnS mixture. Representative values of neutron and γ counting efficiencies for this (optimum LiF-ZnS) detector under standard conditions are shown in Table 3.

TABLE 3
COUNTING EFFICIENCIES (IN PER CENT) FOR OPTIMUM
LiF-ZnS SCINTILLATION DETECTOR

$\bar{E}_n \approx 0.4$ Mev (Po-Li)	$\bar{E}_n \approx 0.7$ Mev (Po-LiF)	$\bar{E}_n \approx 4.0$ Mev (Po-Be)	$E_\gamma = 0.19$ Mev (In ¹¹⁴)	$E_\gamma = 0.66$ Mev (Cs ¹³⁷)	$\bar{E}_\gamma \approx 1.8$ Mev (Ra γ)
0.8	0.4	0.2	$\sim 0.8 \times 10^{-5}$	$\sim 8 \times 10^{-5}$	$\sim 1 \times 10^{-4}$

2.4 Boron Compounds

ZnS(Ag) has been mixed with four selected boron compounds: boric acid, sodium tetraborate, BN, and B₂O₃. * Using a Po-LiF source in standard geometry and with standard gain, curves of counting rate vs thickness of mixture were then determined for each atomic ratio for the four boron compounds. Figure 6 shows the results for the optimum atomic ratio for each of the compounds. Approximately 120 mg/cm² of a 1:1.5 boric acid-ZnS mixture is seen to give a maximum counting rate. Representative values of neutron and γ counting efficiencies for this (optimum boron-ZnS) detector under standard conditions are given in Table 4.

*Previous work on mixtures of solid and liquid boron compounds with ZnS(Ag) is cited in references 3 through 8.

//

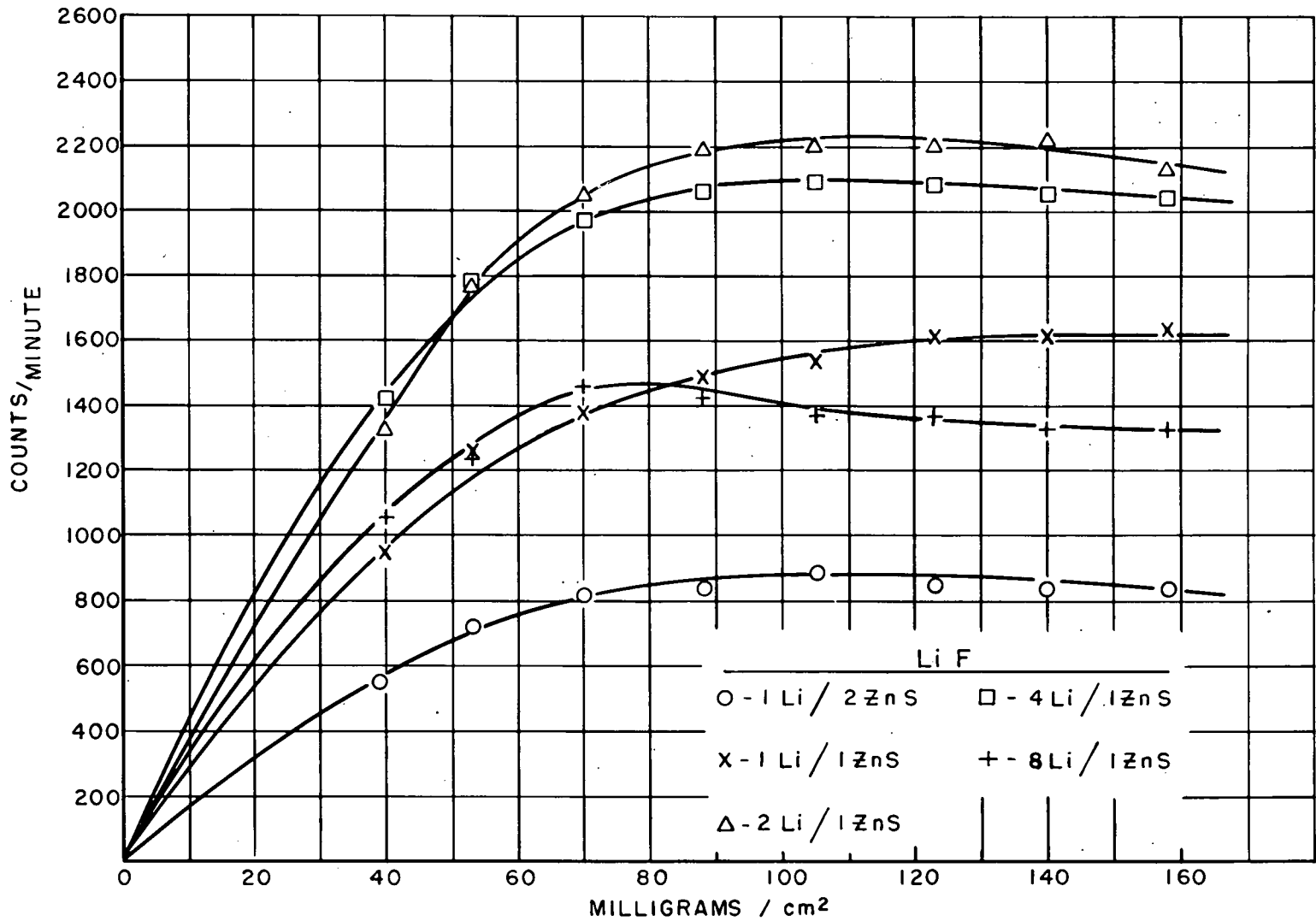

Fig. 5 Neutron counting rate vs thickness for various mixtures of ZnS and LiF.

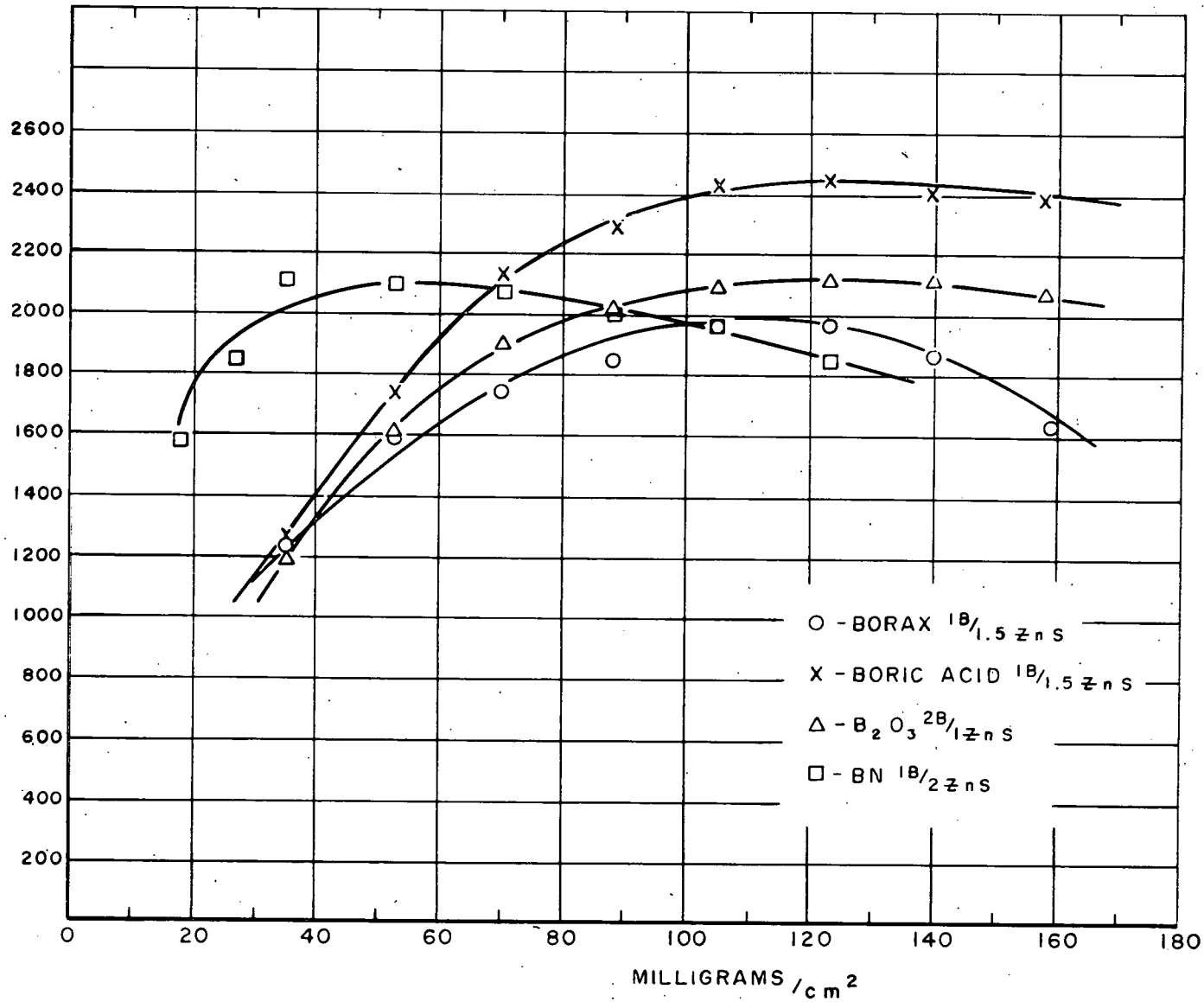

Fig. 6 Neutron counting rate vs thickness for optimum atomic ratios of various ZnS-boron compound mixtures.

TABLE 4
COUNTING EFFICIENCIES (IN PER CENT) FOR OPTIMUM
BORON-ZnS SCINTILLATION DETECTOR

$\bar{E}_n \approx 0.4$ Mev (Po-Li)	$\bar{E}_n \approx 0.7$ Mev (Po-LiF)	$\bar{E}_n \approx 4.0$ Mev (Po-Be)	$E_\gamma = 0.19$ Mev (In ¹¹⁴)	$E_\gamma = 0.66$ Mev (Cs ¹³⁷)	$\bar{E}_\gamma \approx 1.8$ Mev (Ra γ)
1.2	0.6	0.4	$\sim 0.8 \times 10^{-5}$	$\sim 8 \times 10^{-5}$	$\sim 10^{-4}$

The use of enriched B¹⁰ would clearly increase the above neutron counting efficiency without appreciably effecting ϵ_γ .

Counting efficiency was studied as a function of boric acid grain size. Optimum grain size was found to be ~ 0.002 in. with ϵ_n dropping the order of 10% below optimum for grain sizes 0.003 in. and ~ 0.0015 in.

Several boron-ZnS powder mixtures were compression-molded (with and without lucite as a binding agent) into discs of varying thickness. Optimum counting efficiency for all such discs fell considerably below that of the powder mixtures, so this form of detector was not studied further.

2.5 Uranium Compounds

ZnS(Ag) has been mixed with two uranium compounds, uranium acetate and uranium nitrate, and with one thorium compound, ThO₂. * To eliminate background due to α activity of these compounds, it was necessary to operate at $\sim 1/25$ standard gain. Under these conditions curves of counting rate vs thickness of mixture were determined for each atomic ratio for the three compounds. Maximum counting rate was obtained with ~ 115 mg/cm² of 1:6 uranium acetate-ZnS mixture. Representative values of neutron counting efficiencies for this (optimum uranium-ZnS) detector under standard conditions are given in Table 5. At this low gain setting, ϵ_γ is negligible for all γ energies.

*Sun and Shoupp [(Rev. Sci. Instruments, 21, 395 (1950))] have previously detected fast neutrons by adding ThO₂ or UO₂(NO₃)₂ to a mixture of ZnS(Ag) and polystyrene dope paste.

TABLE 5
COUNTING EFFICIENCIES (IN PER CENT) FOR OPTIMUM
URANIUM-ZnS SCINTILLATION DETECTOR

$\bar{E}_n \approx 0.4$ Mev (Po-Li)	$\bar{E}_n \approx 0.7$ Mev (Po-LiF)	$\bar{E}_n \approx 4.0$ Mev (Po-Be)
$\sim 2.6 \times 10^{-3}$	$\sim 1.7 \times 10^{-3}$	$\sim 0.9 \times 10^{-3}$

The use of uranium compounds enriched in U^{235} would greatly increase ϵ_n while having essentially no effect on ϵ_γ . Alburger⁽¹⁶⁾ has used a disc of enriched U^{235} backed by a ZnS-lucite disc as a fission-energy neutron detector. The uranium α activity is essentially self-shielded in this arrangement, and under these conditions, Alburger reports a maximum efficiency of 0.5% for thermal neutrons.

3. Summary and Conclusions

The data of Tables 1 through 5 are summarized in Fig. 7. The 1:1.5 boric acid-ZnS mixture is seen to give the highest neutron counting efficiency.

To show the reciprocal relationship between neutron counting efficiency, ϵ_n , and the ratio of neutron to gamma counting efficiency, $\epsilon_n/\epsilon_\gamma$, we have plotted these two factors vs bias for the boric acid-ZnS mixture in standard geometry using a Po-Li source (cf. Fig. 8). Neutron counting efficiency is seen to increase sharply at low bias voltages with a corresponding decrease in $\epsilon_n/\epsilon_\gamma$ ratio. Thus in principle, neutron counting efficiencies the order of 10% or higher are possible with a corresponding ratio $\epsilon_n/\epsilon_\gamma \approx 500$. Greater counting stability, however, is obtained at higher bias voltages, where neutron counting efficiencies the order of 1% are possible with negligible γ counting efficiency ($< 10^{-5}\%$).

The optimum 1:1.5 boric acid-ZnS mixture has proved very satisfactory for our immediate purpose of counting delayed neutrons from fission of U^{235} in the presence of an intense γ background. It is possible that somewhat higher neutron counting efficiencies may be obtained with other methods of combining boron and ZnS.

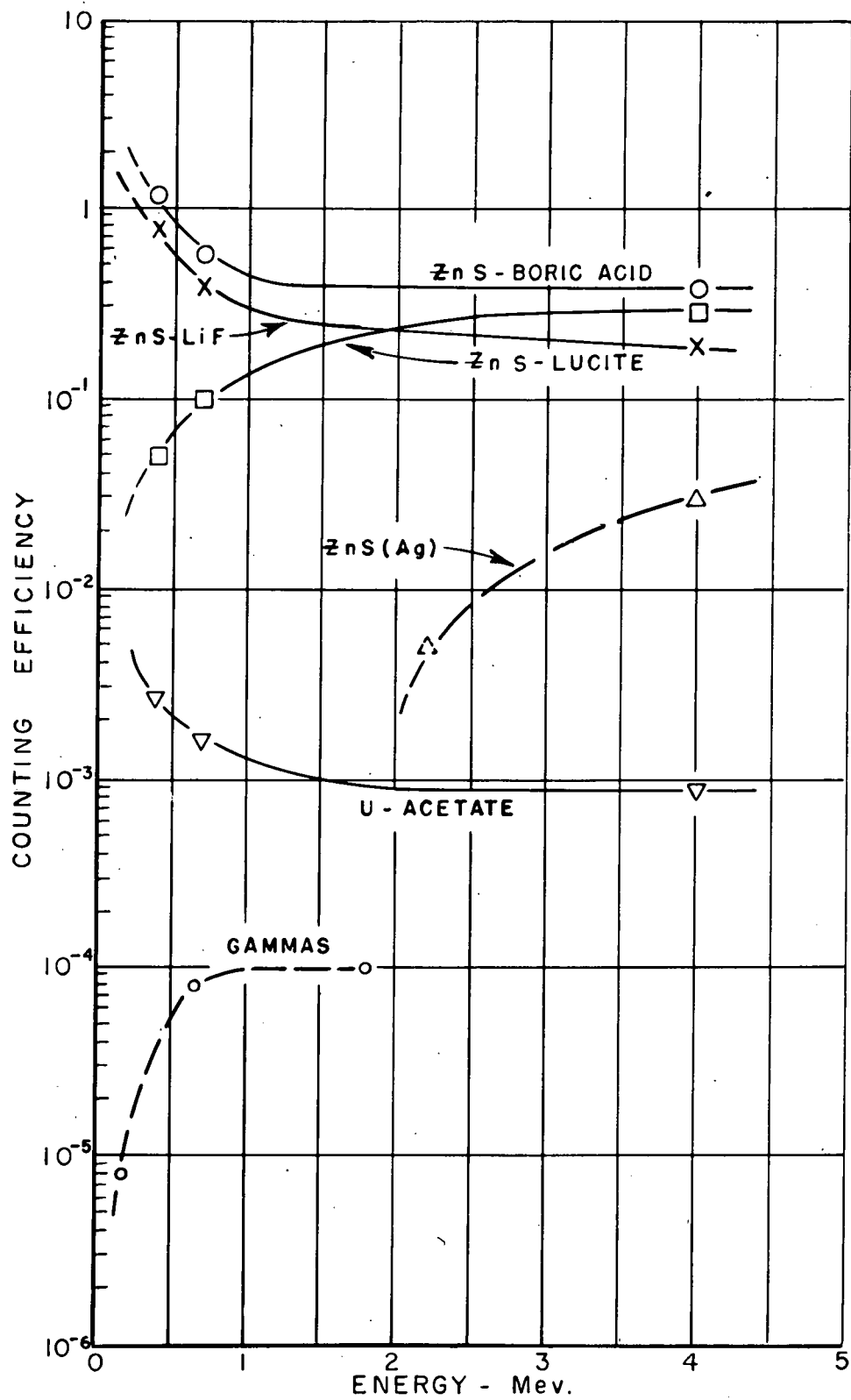

Fig. 7 Neutron and γ counting efficiencies as a function of energy for various optimum detectors in standard geometry.

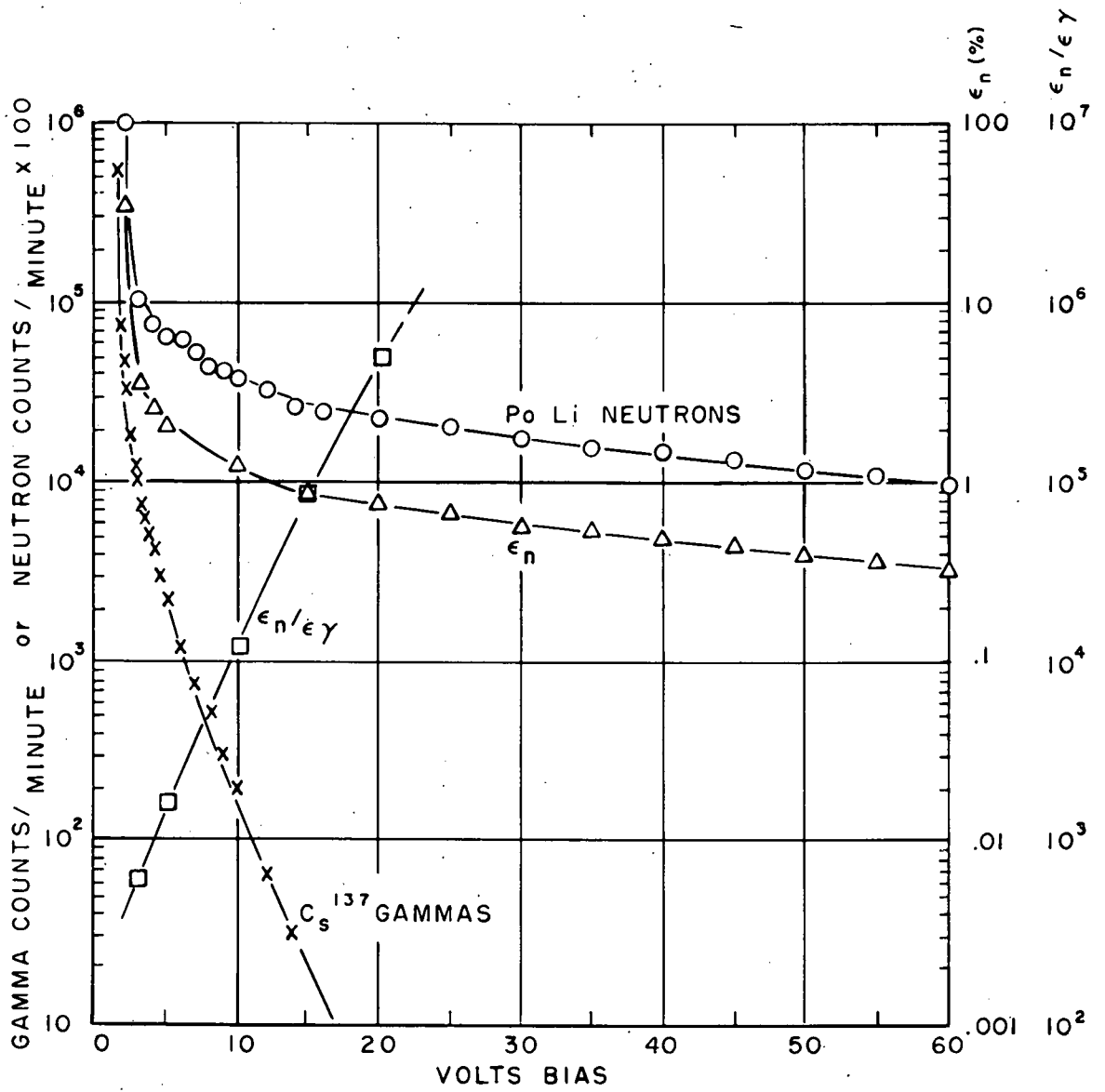

Fig. 8 Counting efficiencies as a function of bias voltage (background corrected).

References

1. W. Moulton and C. Sherwin, Rev. Sci. Instruments, 20, 766 (1949).
2. H. Frey, Rev. Sci. Instruments, 21, 886 (1950).
3. R. Hofstadter, Brookhaven National Laboratory Report BNL-1-7 (1948).
4. J. Schenck, Nucleonics, 10 (No. 8), 54 (1952).
5. D. Alburger, Rev. Sci. Instruments, 23, 769 (1952).
6. C. Muehlhouse, Brookhaven National Laboratory Report BNL-242 (T-38) (1953).
7. Palevsky, Meuther, and Stolovy, Bull. Am. Phys. Soc., 26 (No. 6), 16 (1953).
8. Sun, Malmberg, and Pecjak, Bull. Am. Phys. Soc., 29 (No. 4), 12 (1954).
9. Fitz-Hugh Marshall, Jour. App. Phys., 18, 512 (1947).
10. R. Hofstadter, Nucleonics, 6 (No. 5), 70 (1950).
11. J. Birks, Scintillation Counters, p. 50, McGraw-Hill Book Company, New York, 1953.
12. S. Curran, Luminescence and the Scintillation Counter, p. 131, Butterworth Scientific Publications, London, 1953.
13. W. F. Hornyak, Rev. Sci. Instruments, 23, 264 (1952).
14. W. S. Emmerich, Rev. Sci. Instruments, 25, 69 (1954).
15. G. R. Keepin, Rev. Sci. Instruments, 25, 30 (1954).
16. D. E. Alburger, Rev. Sci. Instruments, 23, 765 (1952).

1-17

THIS PAGE
WAS INTENTIONALLY
LEFT BLANK